



# Thermo. operated water valve

## AVTA

Opens on rising sensor temperature

## Description

Thermostatic operated water valves are used for proportional regulation of flow quantity, depending on the setting and the sensor temperature.

The Danfoss range of thermostatic operated water valves includes a series of products for both refrigeration and heating regulation.

The valves are self-acting, i.e. they operate without the supply of auxiliary energy such as electricity or compressed air.

The required temperature is maintained constant without unnecessary use of:

- Cooling water in cooling systems
- Hot water or steam in heating systems

The operating economy and efficiency are maximized.

AVTA SS for aggressive media:

A valve body in stainless steel means that the valve can be used for aggressive media in such applications as the marine sector and the chemical industry.

## Features & benefits

- Insensitive to dirt
- Insensitive to water pressure
- Needs no power supply – self acting
- Opens on rising sensor temperature
- Differential pressure: 0 – 10 bar
- Maximum working pressure (PS): 16 bar
- Maximum test pressure: 25 bar
- Maximum pressure on sensor: 25 bar and the regulation range is defined for the point at which the valve begins to open
- Stainless steel version available and cooling media temperature range: -25 – 130 °C
- The valves are pressure-relieved, i.e. degree of opening is not affected by differential pressure  $\Delta p$  (pressure drop) and ethylene glycol as a cooling media up to 40%

## Applications

Figure: AVTA



AVTA thermostatic operated water valves are widely used for temperature regulation in many different machines and installations where cooling is required. AVTA cooling water valves always open to admit flow on rising sensor temperature.

The valve can be installed in either the cooling water flow line or the return line.

The standard version of the AVTA thermostatic operated water valve can be used with fresh water or neutral brine.

Typical application areas:

- Injection moulding machines
- Compressors
- Vacuum pumps
- Dry cleaning machines
- Distillation plants
- Printing machines
- Hydraulic systems
- Roller mills
- Biomass boilers
- Industrial lasers
- Steam sterilizers
- Medical equipment
- Food processing

Figure: Applications

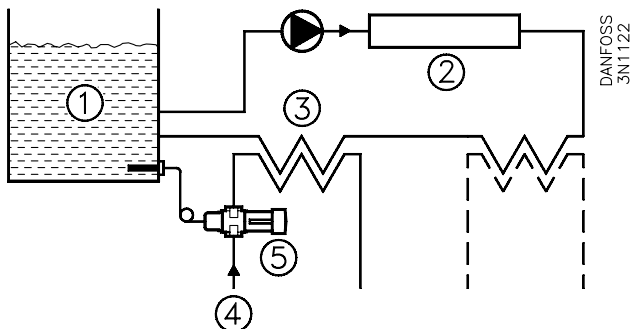

1	Oil tank
2	Hydraulic machinery
3	Heat exchangers
4	Cooling water supply
5	AVTA thermostatic valve

## Ordering

### Product code numbers

#### AVTA with adsorption charge

#### Figure: Sensor installation

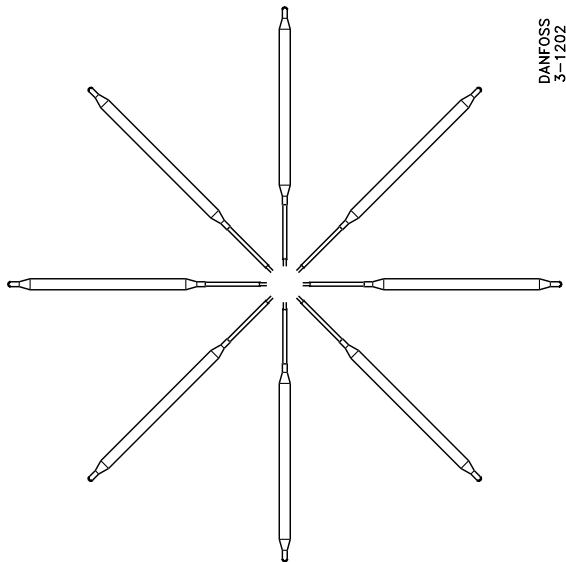

The charge consists of active carbon and CO<sub>2</sub> which is adsorbed on falling sensor temperature, thereby producing a pressure change in the element.

- Wide regulating range
- Can be installed in any position as far as orientation and temperature are concerned
- Small sensor dimensions –  $\varnothing 9.5 \times 150$  mm
- Max. pressure on sensor 25 bar

For immersion pockets, see accessories and spare parts.

**Table: AVTA with adsorption charge**

Connection <sup>(1)</sup>	Regulating range [°C]	Max. temp.sensor [°C]	k <sub>v</sub> value [m <sup>3</sup> /h] at $\Delta p = 1$ bar	Capillary tube length [m]	Type	Code no. <sup>(2)</sup>
G 3/8	10 – 80	130	1.4	2.3	AVTA 10	003N1144
G 1/2	10 – 80	130	1.9	2.3	AVTA 15	003N0107
G 1/2	10 – 80	130	1.9	2.3 (armoured)	AVTA 15	003N2114
G 3/4	10 – 80	130	3.4	2.3	AVTA 20	003N0108
G 1	10 – 80	130	5.5	2.3	AVTA 25	003N0109

<sup>(1)</sup> ISO 228-1.

<sup>(2)</sup> Code no. covers complete valve incl. capillary tube gland.

## AVTA with universal charge

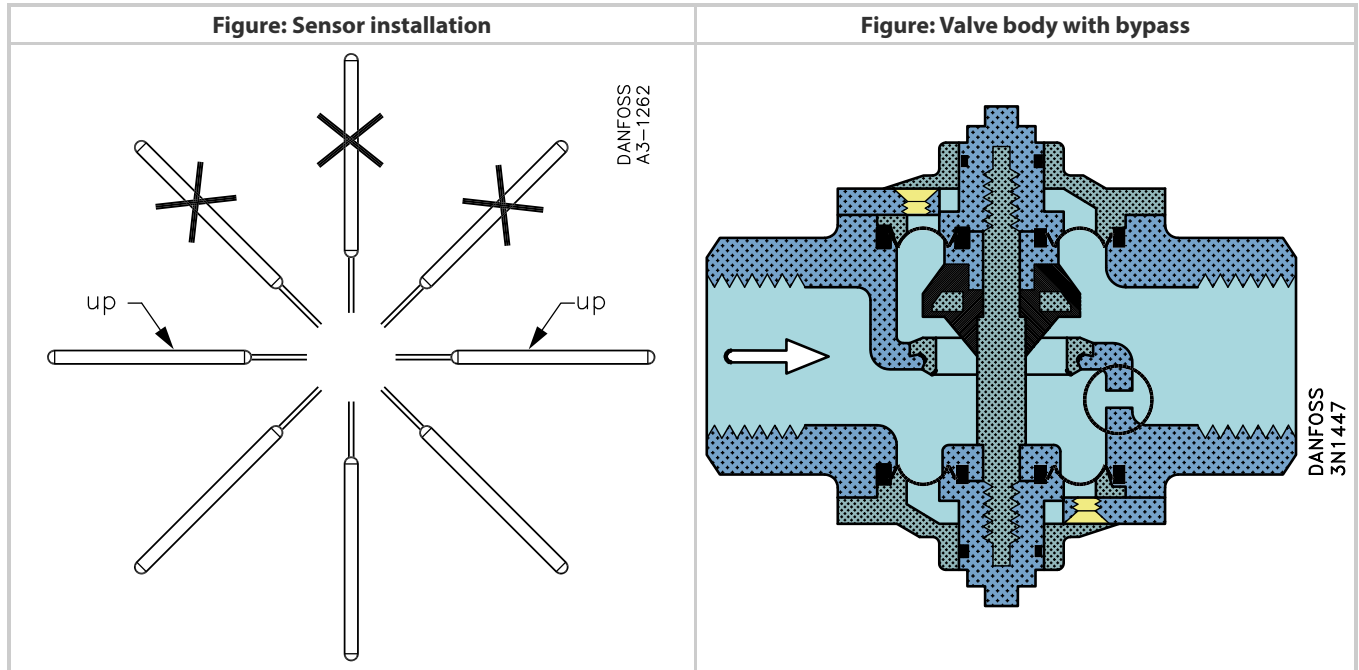

The charge is a mix of liquid and gas where the liquid surface (regulating point) is always inside the sensor. Which charge medium is used depends on the regulation range.

- Sensor dimensions  $\varnothing 18 \times 210$  mm
- Sensor can be installed in a place where it is either colder or warmer than the valve
- Sensors must be orientated as shown in the sketch below
- Max. pressure on sensor 25 bar

For immersion pockets, see accessories and spare parts.

**Table: AVTA with universal charge**

Connection <sup>(1)</sup>	Regulating range [°C]	Max. temp.sensor [°C]	$k_v$ value [m <sup>3</sup> /h] at $\Delta p = 1$ bar	Capillary tube length [m]	Type	Code no. <sup>(2)</sup>
G 3/8	0 – 30	57	1.4	2	AVTA 10	003N1132
G 1/2	0 – 30	57	1.9	2	AVTA 15	003N2132
G 3/4	0 – 30	57	3.4	2	AVTA 20	003N3132
G 1	0 – 30	57	5.5	2	AVTA 25	003N4132
G 3/8	25 – 65	90	1.4	2	AVTA 10	003N1162
G 1/2	25 – 65	90	1.9	2	AVTA 15	003N2162
G 1/2	25 – 65	90	1.9	2.0 (armoured)	AVTA 15	003N0041
G 3/4	25 – 65	90	3.4	2	AVTA 20	003N3162
G 3/4	25 – 65	90	3.4	5	AVTA 20	003N3165
G 3/4	25 – 65	90	3.4	2.0 (armoured)	AVTA 20	003N0031
G 1	25 – 65	90	5.5	2	AVTA 25	003N4162
G 1	25 – 65	90	5.5	2.0 (armoured)	AVTA 25	003N0032
G 1	25 – 65	90	5.5	5	AVTA 25	003N4165
G 3/8	50 – 90	125	1.4	2	AVTA 10	003N1182
G 1/2	50 – 90	125	1.9	2	AVTA 15	003N2182
G 3/4	50 – 90	125	3.4	2	AVTA 20	003N3182
G 1	50 – 90	125	5.5	2	AVTA 25	003N4182
G 1	50 – 90	125	5.5	2	AVTA 25	003N4183 <sup>(3)</sup>

<sup>(1)</sup> ISO 228-1.<sup>(2)</sup> Code no. covers complete valve incl. capillary tube gland.<sup>(3)</sup> A  $\varnothing 2$  mm bypass is drilled in the valve body.

## AVTA with mass charge

### Figure: Sensor installation

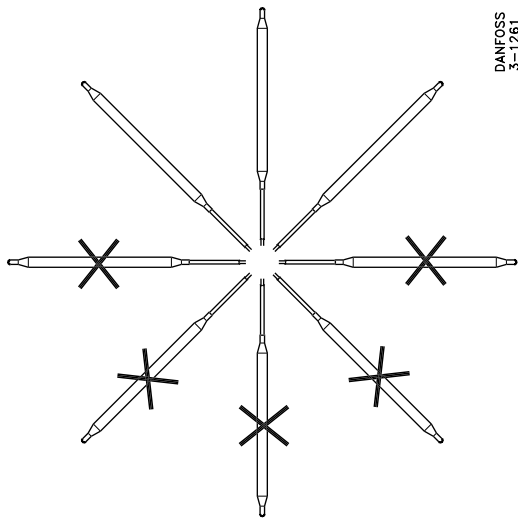

The charge is a mix of liquid and gas. Due to the mixture of liquid and gas the sensor must be installed in an area or environment that is warmer than the valve.

- Small sensor dimensions –  $\varnothing 9.5 \times 180$  mm
- Short time constant
- Max. pressure on sensor 25 bar

**Table: AVTA with mass charge**

Connection <sup>(1)</sup>	Regulating range [°C]	Max. temp.sensor [°C]	$k_v$ value [m <sup>3</sup> /h] at $\Delta p = 1$ bar	Capillary tube length [m]	Type	Code no. <sup>(2)</sup>
G ½	0 – 30	57	1.9	2	AVTA 15	003N0042
G ¾	0 – 30	57	3.4	2	AVTA 20	003N0043
G ½	25 – 65	90	1.9	2	AVTA 15	003N0045
G ½	25 – 65	90	1.9	2.0 (armoured)	AVTA 15	003N0299
G ½	25 – 65	90	1.9	5	AVTA 15	003N0034
G ¾	25 – 65	90	3.4	2	AVTA 20	003N0046
G 1	25 – 65	90	5.5	2	AVTA 25	003N0047

<sup>(1)</sup> ISO 228-1

<sup>(2)</sup> Code no. covers complete valve incl. capillary tube gland.

## AVTA in stainless steel with adsorption charge

### Figure: Sensor installation

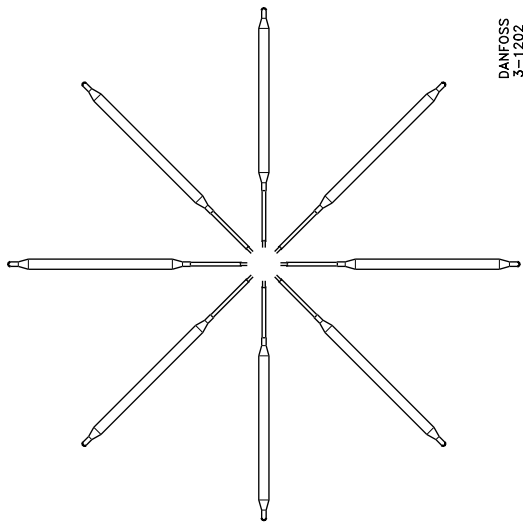

- Wide regulating range
- Can be installed in any position as far as orientation and temperature are concerned
- Small sensor dimensions –  $\varnothing 9.5 \times 150$  mm
- Max. pressure on sensor 25 bar
- AVTA SS mass and universal charges available on request

For immersion pockets, see accessories and spare parts.

**Table: AVTA in stainless steel with adsorption charge**

Connection <sup>(1)</sup>	Regulating range [°C]	Max. temp.sensor [°C]	$k_v$ value [m <sup>3</sup> /h] at $\Delta p = 1$ bar	Capillary tube length [m]	Type	Code no. <sup>(2)</sup>
G 1/2	10 – 80	130	1.9	2.3	AVTA 15	003N2150
G 3/4	10 – 80	130	3.4	2.3	AVTA 20	003N3150
G 1	10 – 80	130	5.5	2.3	AVTA 25	003N4150

<sup>(1)</sup> ISO 228-1.

<sup>(2)</sup> Code no. covers complete valve incl. capillary tube gland.

## Accessories code numbers

Table: Accessories

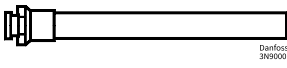
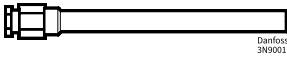
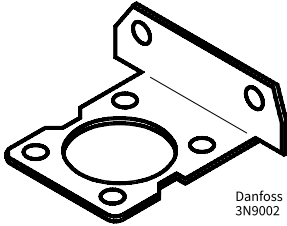
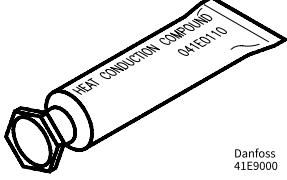
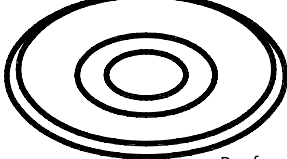
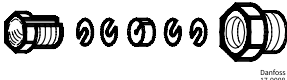
	Designation	Description	Code no.
 Danfoss 3N9004	Immersion sensor Max. pressure 50 bar L = 220 mm	Brass for $\varnothing 18$ sensor G $\frac{3}{4}$	003N0050
		Brass for $\varnothing 18$ mm, sensor $\frac{3}{4}$ – 14 NPT	003N0051
		18/8 steel (1) for $\varnothing 18$ sensor, $\frac{3}{4}$ – 14 NPT	003N0053
		18/8 steel (1) for $\varnothing 18$ sensor R $\frac{3}{4}$	003N0192
 Danfoss 3N9001	Immersion sensor Max. pressure 50 bar L = 182 mm	Brass for $\varnothing 9.5$ sensor G $\frac{1}{2}$	017-436766
		18/8 steel (1) for $\varnothing 9.5$ sensor R $\frac{1}{2}$	003N0196
 Danfoss 3N9002	Mounting bracket	For AVTA	003N0388
 Danfoss 41E9000	Heat-conductive compound	5 gram tube	041E0110
		0.8 kg	041E0111
 Danfoss 3N9005	Set of 3 nitrile (NBR) diaphragms sets for mineral oil	For AVTA 10/15, 20, 25	003N0448
 Danfoss 31-9008	Capillary tube gland	G $\frac{1}{2}$	017-422066
		G $\frac{3}{4}$	003N0155
		$\frac{1}{2}$ – 14 NPT	003N0157
		$\frac{3}{4}$ – 14 NPT	003N0056
	Plastic hand knob	For AVTA	003N0520

<sup>(1)</sup> W. no. 1.4301.

## Spare parts code numbers

Figure: Thermostatic elements for AVTA valves

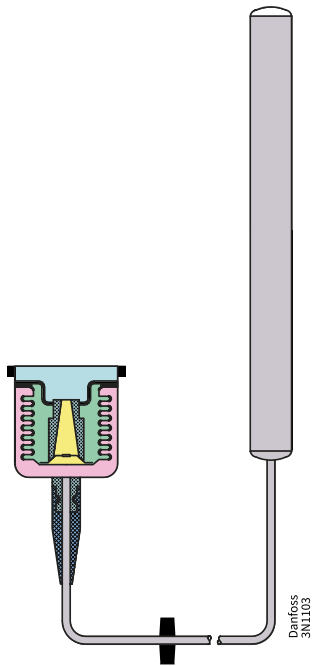

Table: Spare parts

Thermostatic elements	Temperature range [°C]	Capillary tube length [m]	Code no.
Adsorption charge – sensor $\varnothing 9.5 \times 150$ mm	10 – 80	2.3	003N0278
Universal charge – sensor $\varnothing 18 \times 210$ mm	0 – 30	2	003N0075
	0 – 30	5	003N0077
	25 – 65	2	003N0078
	25 – 65	5	003N0080
	50 – 90	2	003N0062
Mass charge – sensor $\varnothing 9.5 \times 180$ mm	25 – 65	2	003N0091
	25 – 65	5	003N0068

## Functions

### How it works:

When the three elements have been assembled together, the valve installed and the sensor located at the point where the temperature is to be regulated, the function sequence is as follows:

1. The pressure changes in the sensor as a result of a change in temperature - builds up in the sensor.
2. This pressure is transferred to the valve via capillary tube and bellows and acts as an opening or closing force.
3. The knob on the setting section and the spring exert a force that acts counter to the bellows.
4. When balance is created between the two opposing forces, the valve spindle remains in its position.
5. If the sensor temperature changes or if the settings are changed – the point of balance becomes displaced and the valve spindle moves until balance is re-established, or the valve is fully open or closed.
6. The flow quantity change is approximately proportional to sensor temperature change.

Figure shows an AVTA cooling water valve, but the function principle applies to all types of thermostatic valves.

**Figure: Thermostat operated water valves consist of three main elements**

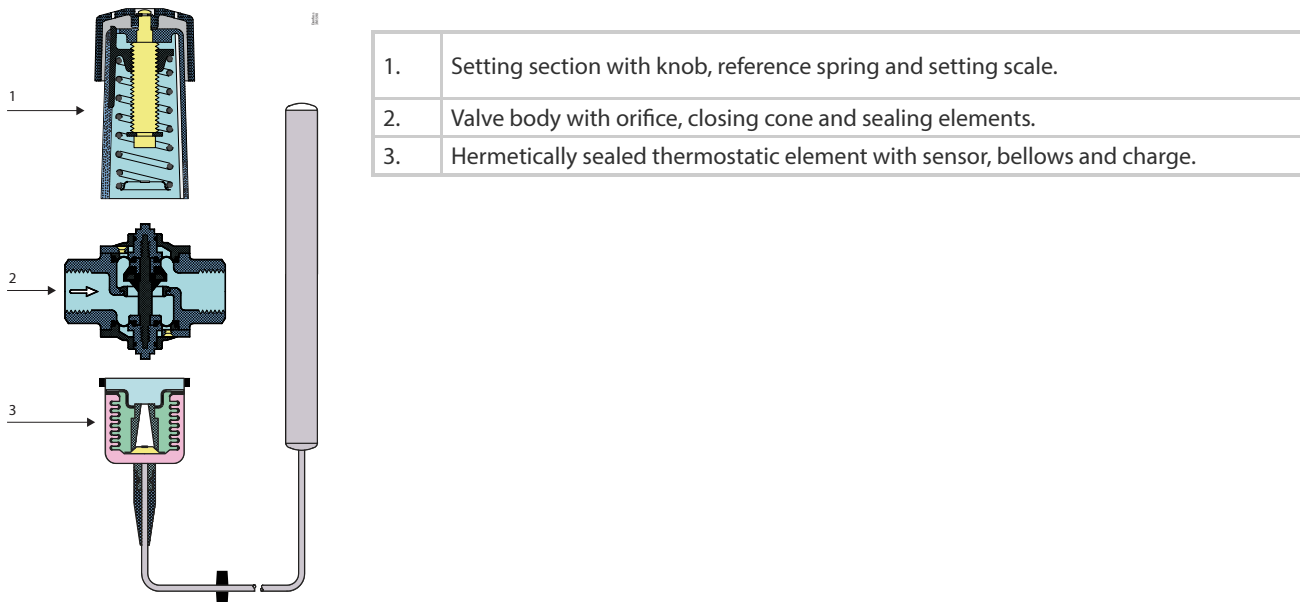

## Product details

### Materials

Figure: Materials for AVTA and AVTA SS

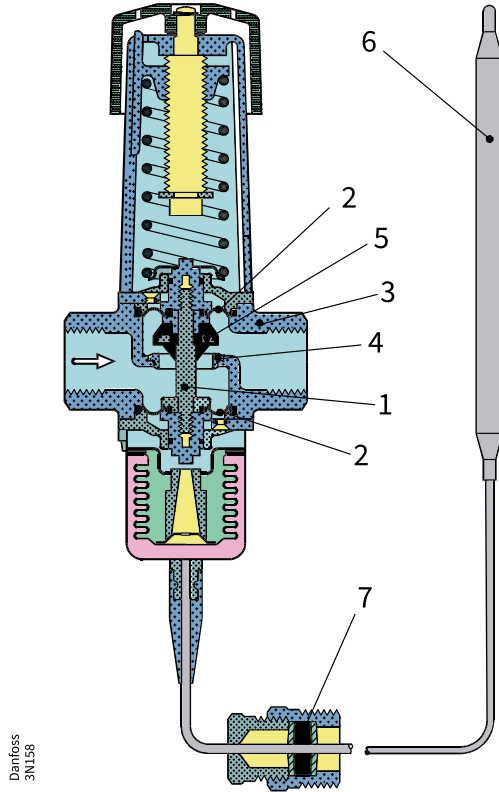

Table: Materials

No.	Description	Material AVTA	Material AVTA SS
1	Spindle	Brass	Stainless steel
2	Diaphragms	Rubber – ethylene – propylene (EPDM)	
3	Valve body and other metal parts	Forged brass	Stainless steel
4	Valve seat	Stainless steel	
5	Valve cone	Nitrile rubber (NBR)	
6	Sensor	Copper	
7	Capillary tube gland	Nitrile rubber (NBR) / brass	

### Types of charges

Table: ATVA thermostatic operated water valves with different types of charge.

Universal charge	Mass charge	Adsorption charge

## Dimensions

Figure: Types of sensors

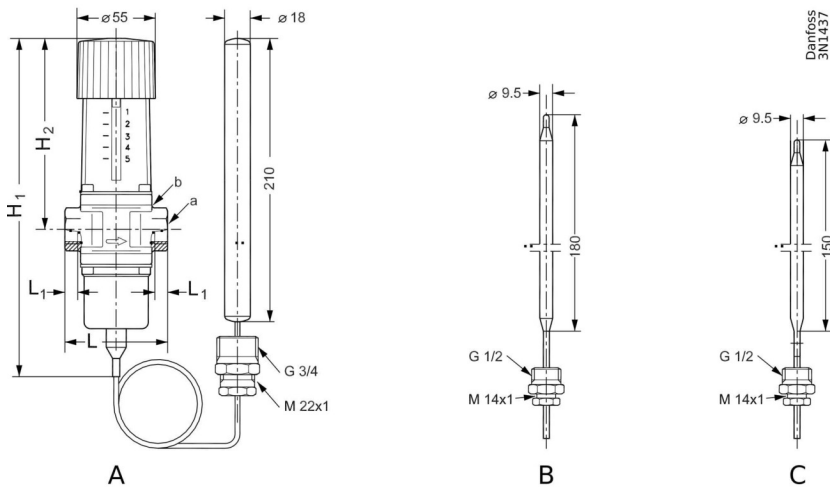

<b>A</b>	Universal sensor
<b>B</b>	Mass sensor
<b>C</b>	Adsorption sensor

Figure: Valves in brass and stainless-steel housings

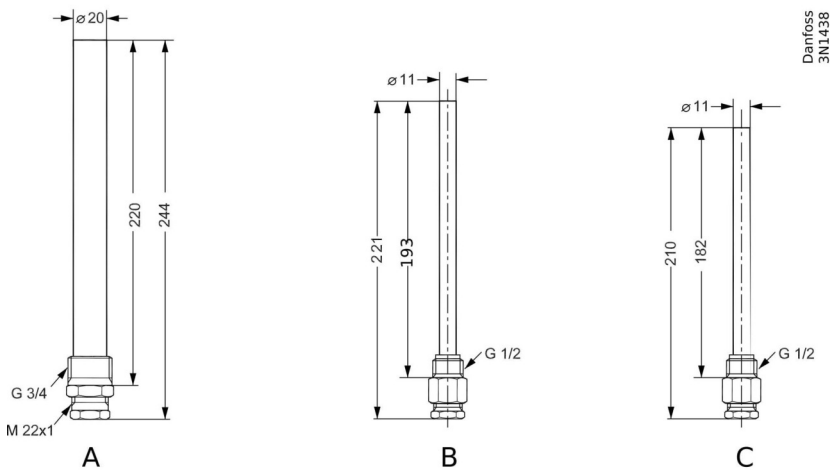

<b>A</b>	Brass/stainless steel pockets for universal sensor
<b>B</b>	Stainless steel pockets for mass/adsorption sensor
<b>C</b>	Brass pocket for mass/adsorption sensor

## Dimensions [mm] and weights [kg] of AVTA valves in brass and stainless-steel housings

Table: Dimensions and weights

Type	H <sub>1</sub>	H <sub>2</sub>	L	L <sub>1</sub>	a	b	Net weight
AVTA 10	240	133	72	14	G 3/8	27	1.45
AVTA 15	240	133	72	14	G 1/2	27	1.45
AVTA 20	240	133	90	16	G 3/4	32	1.5
AVTA 25	240	138	95	19	G 1	41	1.65

## Installation

### AVTA with mounting bracket

Figure: AVTA

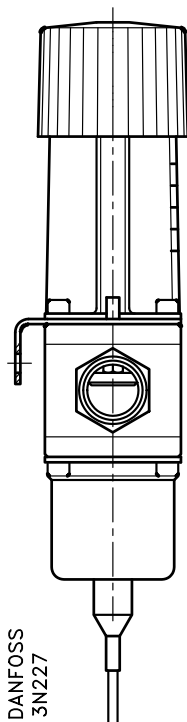

The valves can be installed in any position. An arrow on the valve body indicates the direction of flow.

AVTA valves are marked so that the letters RA are the right way up when the valve is held as shown. The installation of an FV filter ahead of the valve is recommended.

#### Capillary tube

Install the capillary tube without sharp bends (no "kinks"). Make sure that there is no strain on the capillary tube at the ends. Relief is important where vibration might occur.

**NOTE:** When an AVTA valve is used, the sensor must be able to react to variations in cooling water temperature on system start. Therefore, a bypass line with a shut-off valve might be necessary to ensure flow at the sensor during start-up. If a mounting bracket is used – see [accessories](#) and [spare parts](#) – it must always be positioned between the valve body and the setting section (see illustration).

#### Sizing

When sizing and selecting thermostatic operated water valves, it is most important to ensure that the valve is able to give the necessary quantity of cooling water at any time, irrespective of the load. Therefore, to select a suitable size of valve it is necessary to know the precise amount of cooling required. On the other hand, to avoid the risk of unstable regulation (hunting), the valve should not be oversized.

The type of charge must be selected on the basis of the temperature to be maintained, and on an assessment of the characteristics of each type, as described in the foregoing.

In general, the aim should be to select the smallest valve capable of giving the required flow.

It is also recommended that the temperature range be chosen so that the required sensor temperature lies in the middle of the regulation range.

To help fine setting the valve, a thermometer should be installed near the sensor.

### Valve size

The following data are used when selecting the valve size:

- Required cooling water flow,  $Q$  [ $\text{m}^3/\text{h}$ ]
- Temperature rise in cooling water,  $\Delta t$  [ $^{\circ}\text{C}$ ]
- Differential pressure across valve,  $\Delta p$  [bar]

With fully open valve, the differential pressure should be around 50% of the total pressure drop across the cooling system.

The following chart are intended to make valve sizing easier.

Figure: Heating or cooling with water

Figure: Relation between water quantity and pressure drop across valve

Figure: Nomogram showing the valve  $k_v$  range

Figure: Valve flow quantity in fully open position, as a function of pressure drop  $\Delta p$ .

### Example:

A cooling water valve must be selected for the temperature regulation of a vacuum pump.

Since direct regulation of the oil temperature is required, an AVTA valve is suitable. The sensor position is horizontal – and small dimensions are desired.

Given data:

- Necessary cooling at full load 10 kW
- Oil temperature to be maintained constant at  $45^{\circ}\text{C}$
- Cooling water  $p_1 = 3$  bar
- Outlet  $p_3 = 0$  bar
- $p_2 = \frac{p_1 + p_3}{2}$  (guess)
- Cooling water temperature  $t_1 = 20^{\circ}\text{C}$
- Outlet temperature  $t_2 = 30^{\circ}\text{C}$

The graphs in figure: Heating or cooling with water can be used to find the necessary cooling water quantity at  $\Delta t = 10^{\circ}\text{C}$  ( $30 - 20^{\circ}\text{C}$ ) to  $0.85 \text{ m}^3/\text{h}$ .

The graphs in figure: Relation between water quantity and pressure drop across valve show the necessary  $k_v$  value for  $0.85 \text{ m}^3/\text{h}$  with  $\Delta p = p_1 - p_2 = 3 - 1.5 = 1.5$  bar for  $0.7 \text{ m}^3/\text{h}$ .

The columns in figure: Nomogram showing the valve  $k_v$  range show that all four AVTA valves can be used, but in practice an AVTA 10 or 15 shall be selected, so the necessary water flow is in the middle of the regulating range.

The above considerations apply to both AVTA and FJVA types.

Operating conditions and other product requirements in this example mean that a valve with adsorption charge is the correct choice. The temperature range  $10 - 80^{\circ}\text{C}$  is in order.

Table: AVTA with adsorption charge shows AVTA 10, code no. 003N1144, or AVTA 15, code no. 003N0107. Both fulfil the requirements named.

In many applications, installation conditions make the use of sensor pockets advisable.

Accessories give the code nos. for sensor pockets for  $\varnothing 9.5$  mm sensors in brass and stainless steel: 017-436766 and 003N0196, respectively.

Figure: Connection

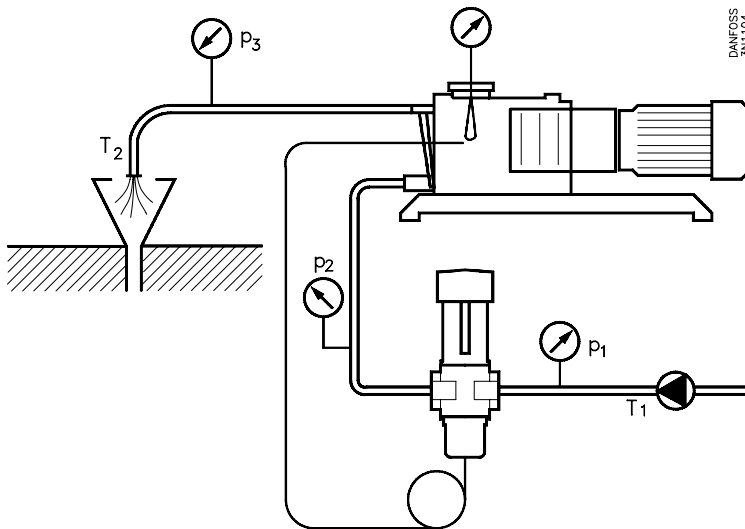
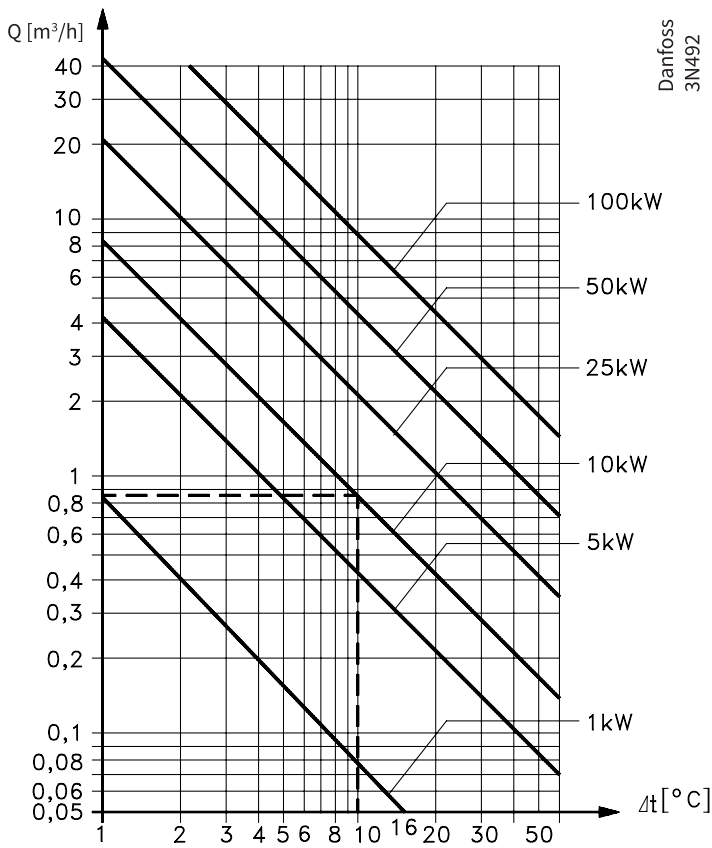

Figure: Heating or cooling with water7



**Example:**

Necessary cooling output 10 kW with  $\Delta t = 10^\circ\text{C}$

Required flow  $0.85 \text{ m}^3 / \text{h}$

**Figure: Relation between water quantity and pressure drop across valve**

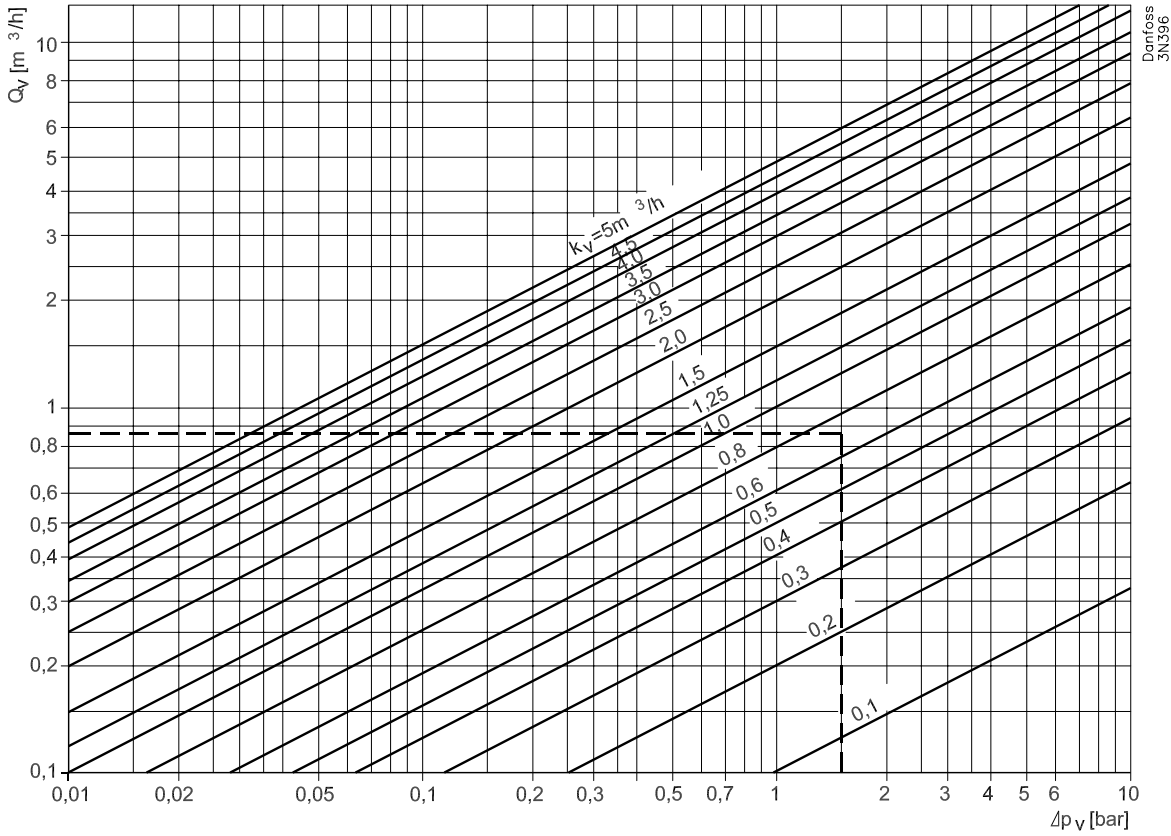

Danfoss  
3N396

**Example:**

Flow  $0.85 \text{ m}^3/\text{h}$  with a pressure drop of 1.5 bar.

The  $k_v$  value becomes  $0.7 \text{ m}^3/\text{h}$ .

**Figure: Nomogram showing the valve  $k_v$  range**

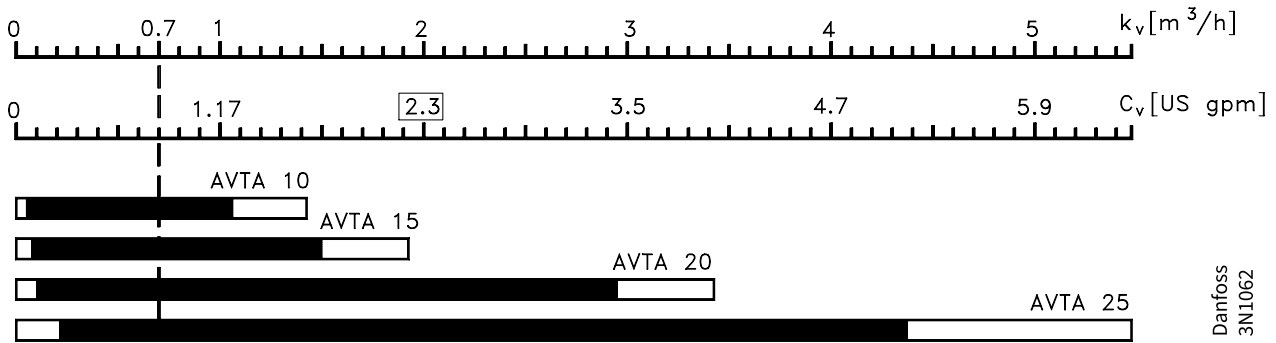

Danfoss  
3N1062

$K_v$  values are always given for water flow in  $[\text{m}^3/\text{h}]$  with a pressure drop  $\Delta p$  of 1 bar.

The valve should be selected so that the necessary  $k_v$  value lies in the middle of the regulation range.

**Example:**

AVTA 10 and 15 are the most suitable for a  $k_v$  value of 0.7

**Figure: Valve flow quantity in fully open position, as a function of pressure drop  $\Delta p$ .**

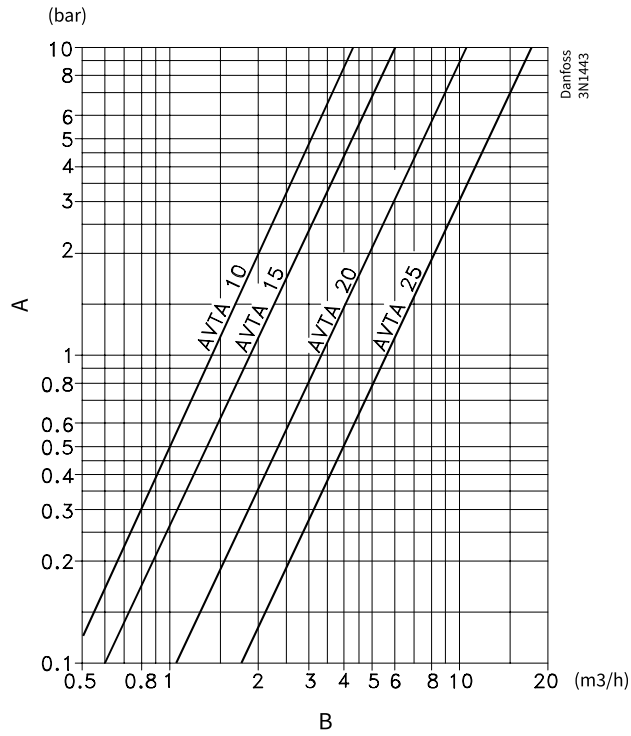

A	Pressure drop across valve
B	Capacity with fully open valve

**Options**

- DZR brass
- Outer thread connecting
- Other lengths of capillary tubes
- Armouring of capillary tubes
- Other combinations of sizes, materials and ranges
- NPT – connection, see separate datasheet for USA / Canada

## Certificates, declarations and approvals

The list contains all certificates, declarations, and approvals for this product type. Individual code number may have some or all of these approvals, and certain local approvals may not appear on the list.

When you click on the link you will be directed to the latest version of the 'Declaration of Conformity'. Products developed and sold before this date of issue conform to the directives/standards in force at the time of their sale.

Approval type	Title	Certification body	Approval topic
Manufacturer's Declaration	<a href="#">Danfoss MD 003N9613.AB</a>	Danfoss	PED, Pressure
Export Control Declaration	<a href="#">Water regulating valves</a>	Danfoss	
Pressure Safety Certificate	<a href="#">LLC CDC EURO-TYSK</a> <a href="#">UA.TR.089.1015.02-22</a>	LLC CDC EURO TYSK - Ukraine	PED, Pressure
Manufacturer's Declaration	<a href="#">Danfoss MD 003N9614.AA</a>	Danfoss	China RoHS
Manufacturer's Declaration	<a href="#">Danfoss MD 003N9617.AC</a>	Danfoss	PED, Pressure, EU RoHS

## Contact details

### Online support

Danfoss offers a wide range of support along with our products, including digital information, software, mobile apps and expert guidance. See the possibilities below.



#### The Danfoss Design center

Discover the Design Center, our advanced digital platform that streamlines product selection. With integrated tools and enhanced type pages, it's simpler than ever to access product information and documentation, and to select the right products. Check the availability of Danfoss products at partner locations and enjoy seamless transitions from selection to purchase with our basket-to-basket functionality. Whether you're buying from our distributors or directly from the Product Store, the Design Center simplifies your experience. Learn more at: [designcenter.danfoss.com](https://designcenter.danfoss.com).



#### The Danfoss product store

The Danfoss Product Store is a one-stop shop available 24/7 for our customers, no matter where you are in the world or what area of industry you work in. Browse our catalog, check product details and documentation, view your prices and product availability, and quickly finalize your purchase. Start browsing at: [store.danfoss.com](https://store.danfoss.com).



#### Danfoss Partner Portal/Product Data tool

Designed to support you with easy access to product data extracts, essential resources, tools, and information. The Partner Portal provides a centralized hub for product documentation, training materials, marketing assets, and technical support, ensuring you have everything you need to succeed and grow your business with Danfoss. The Partner Portal is available 24/7 at: [partner.danfoss.com](https://partner.danfoss.com) and is ready to support your business.



#### Find technical documentation

Find technical documentation you need to get your project up running. Get direct access to our official collection of data sheets, certificates and declarations, manuals and guides, 3D models and drawings, case stories, brochures, and much more. Start searching now at: [documentation.danfoss.com](https://documentation.danfoss.com).



#### Danfoss Learning

Danfoss Learning is a free online learning platform. It features courses and materials specifically designed to help engineers, installers, service technicians, and wholesalers better understand the products, applications industry topics, and trends that will help you do your job better. Find your local Danfoss website here: [learning.danfoss.com](https://learning.danfoss.com).



#### Get local information and support

Local Danfoss websites are the main sources for help and information about our company and products. Find product availability, get the latest regional news, or connect with a nearby expert - all in your own language. Find your local Danfoss website here: [danfoss.com](https://danfoss.com).

#### Danfoss A/S

Climate Solutions . danfoss.com . +45 7488 2222

---

Any information, including, but not limited to information on selection of product, its application or use, product design, weight, dimensions, capacity or any other technical data in product manuals, catalogues description, advertisements, etc. and whether made available in writing, orally, electronically, online or via download, shall be considered informative, and is only binding if and to the extent, explicit reference is made in a quotation or order confirmation. Danfoss cannot accept any responsibility for possible errors in catalogues, brochures, videos and other material. Danfoss reserves the right to alter its products without notice. This also applies to products ordered but not delivered provided that such alterations can be made without changes to form, fit or function of the products. All trademarks in this material are property of Danfoss A/S or Danfoss group companies. Danfoss and the Danfoss logo are trademarks of Danfoss A/S. All rights reserved.

---