

Instructions

Packaged condensing unit

Optyma™ iCO₂ (Transcritical/Inverter)

Universal application

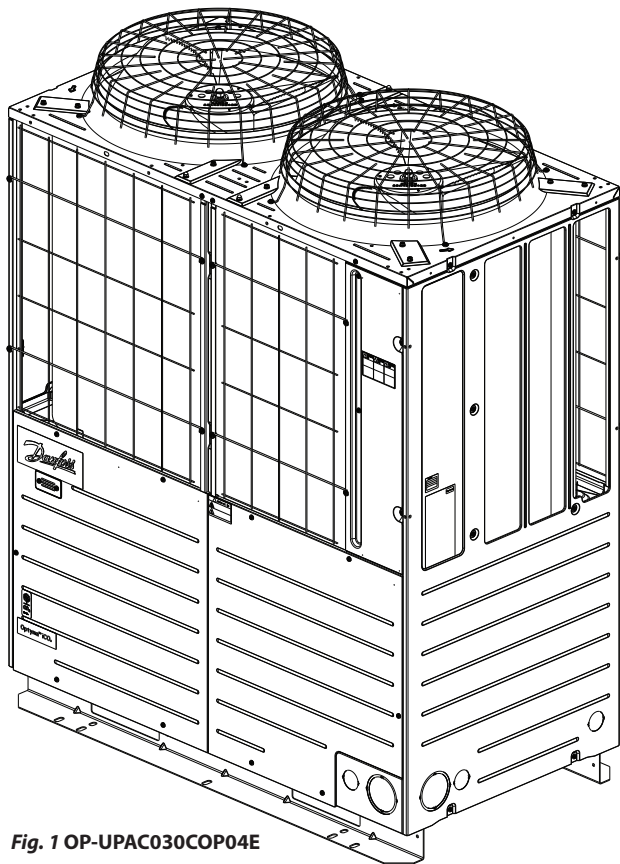

Fig. 1 OP-UPAC030COP04E

1 – Introduction	6
2 – Handling and storage	7
3 – Installation precautions	7
4 – Installation	9
5 – Pressure test	14
6 – Vacuum dehydration.....	15
7 – Electrical connections.....	23
8 – Filling the system.....	25
9 – Setting the electronic controller.....	26
10 – Procedure and caution for commissioning	37
11 – Operation.....	40
12 – Check with running unit.....	41
13 – Guidance at delivery	41
14 – Maintenance.....	41
15 – Declaration of incorporation	46
16 - Warranty.....	46
17 – Disposal	47
18 – Servicing	48
Annex A - Technical data.....	51
Annex B - PID and GA.....	53
Annex C - Wiring diagram	57
Annex D - Outline of installation	59
Annex E - Outline of refrigerant	60
Annex F - Check list.....	61

Instructions

Optyma™ iCO₂

OP-UPAC030COP04E

















	WARNING	This indicates a potentially hazardous situation which, if not avoided, will result in death or serious injury.		Indicates Prohibition.
	CAUTION	This indicates a hazardous situation which, if not avoided, could result in injury to operator or material loss only.		Indicates a compulsory matter. It indicates an instruction on general act of user, which is not specified.
				Indicates a compulsory matter. Indicates that it must be earthed

To facilities designer and installer

- Read the “Safety precautions” carefully before installation.
- After reading the manual, keep it at a place where you can refer to whenever it is necessary.

Installation, electrical work and test run		
	Have the unit installed by your agent or specialized contractor. Electrical work needs to be done by a qualified electrical work contractor. Improper installation made by yourself may cause electric shock, or fire.	
	Installation should be made properly according to this manual. Otherwise it may cause electric shock, or fire.	
	Install the condensing unit (CDU) on a sturdy foundation that can bear its weight sufficiently. Imperfect installation may cause injury if it collapses or crumbles.	
	Where it is installed in a small room, take measures to prevent the refrigerant from accumulating beyond the critical concentration. For the measures, consult with your dealer. When the refrigerant has leaked in the room, and accumulated beyond the critical concentration, it could cause suffocation if the space in the room is limited.	
	Implement the electrical work according to this manual, and use always dedicated circuits. If it fails to observe descriptions in the manual, the capacity of circuits becomes insufficient, or the work is done improperly, it could cause electric shock, or fire.	
	Implement the class D grounding by professional electrical work contractor. Do not connect the grounding cable to the gas pipe, water work pipe, lightning rod, or grounding cable of telephone. Imperfect grounding could cause electric shock, or fire.	
	Be sure to install the earth leakage breaker according to appropriate local standard where the unit is installed. Unless it is installed, it could cause fire, or electric shock, owing to ground fault.	
	Tighten wire terminals securely to specified torque. If they are not tightened securely, it could cause fire, or electric shock, owing to overheat on the terminal.	
	Use specified cables for wiring, and connect them securely, avoiding external force. If they are not connected, or fixed, securely, it could cause fire.	
	When wiring at site, take care to avoid wires being bit, by small animals like rat. If they are damaged, it could cause fire.	
	To wash refrigerant pipes, use cleaning solution which is not combustible, or toxic. Use of combustible material like alcohol or ether could cause explosion, or fire.	
	Wash refrigerant pipes at outdoor, or where it can be ventilated sufficiently. There is risk of oxygen shortage. If open flame is present nearby, it could generate toxic gas.	
	When using a burner, take care not to burn nearby parts, oil return pipe, or sound insulation cover. If the oil return cover is burned, oil under high pressure will burst out, causing fire, or injury.	

Instructions

Installation, electrical work and test run		
 WARNING	<p>Before starting brazing work, evacuate combustible matters from around the site. It could cause fire. Provide a fire extinguisher at the work place.</p>	
	<p>Implement the airtight test. If refrigerant leaks, it could cause oxygen shortage.</p>	
	<p>Open, and close, all valves according to instructions given on nameplates, or this manual. If the valves are opened or closed incorrectly, there is a risk of injury due to refrigerant spouting or the internal pressure of the equipment increasing, causing the refrigerant system to burst.</p>	
	<p>When handling refrigerant, put on leather gloves. Direct contact with hand could cause frostbite, or injury.</p>	
	<p>Always use nitrogen gas for airtight test. If oxygen gas, acetylene gas, fluorocarbon gas, is used by mistake, it could cause explosion, or poisoning.</p>	
	<p>This condensing unit is specially designed for use of R744. It is strictly prohibited to mix any material other than R744 during installation, repair, or relocation. If other refrigerant, or other combustible materials like air, oxygen, propane, or alcohol, are mixed, it could cause explosion, fire, or injury.</p>	
 CAUTION	<p>Avoid installing at a place where combustible gas may leak. If the gas leaks, and accumulates around the condensing unit, it could catch fire.</p>	
	<p>Ventilate effectively. If refrigerant leaks accidentally, it could cause oxygen shortage.</p>	
	<p>Be sure to provide suitable sewer. If frost adhered to the surface of equipment melts, and flows out, it could wet around the equipment.</p>	
	<p>Place a sign board prohibiting people other than operating personnel from touching the condensing unit, or enclose it with protective fence. If it is mishandled, it could cause injury.</p>	
	<p>Produce the refrigerant cycle within the range of specifications. If it is produced beyond the range, it could cause rupture, smoke, fire, or electric shock.</p>	
	<p>Turn off the source power supply before starting maintenance in the condensing unit.</p>	
	<p>Use a circuit breaker with the contact gap of category 3, or higher, at the source power supply.</p>	
	<p>Shield communication cables used for communication with and remote monitoring of the indoor unit.</p>	









Instructions





To personnel for daily operation and control

- Please read this "Safety precautions" carefully beforehand to use the unit properly.
- Servicing needs to be performed by qualified personnel, who are approved by us, or specialized personnel, who are specified by us.

During operation		
	Do not operate with covers removed from the condensing unit. If you touch live internal electric parts, it could cause electric shock.	
	None but qualified personnel is allowed to unfasten, or remove, wiring connection. Inside of pipes on the condensing unit is highly pressurized. Handling by unqualified person could result in serious accident.	
	Do not modify, or change, the main unit of condensing unit. It could cause serious accident.	
 WARNING	Do not remove the protective net from the air blow outlet. Do not poke at the inside with fingers or stick. You could get hurt by the fan running at high speed.	
	When the condensing unit will not stop after taking proper steps for stop, shut down all power supplies immediately. It could cause electric shock, fire, or explosion. In such occasion, consult immediately with your dealer or customer service desk specified by maker.	
	If refrigerant has leaked, stop operation immediately. Ventilate the place with care to sweep over the floor, and consult with your dealer or customer service desk specified by maker. Since the refrigerant is heavier than air, it tends to accumulate over the floor, which could cause oxygen shortage. Report the accident to your dealer, or customer service desk of maker.	
	When any abnormal condition (burning smell) is encountered, stop operation immediately, and turn off the source power supply. If operation is continued without repair, it could cause failure, electric shock, or fire. Consult with your dealer or customer service desk specified by maker.	
	When a protective device trips repeatedly or operation of "ON/OFF" switch is not reliable, shut down the source power supply immediately. Since earth leakage, or over-current, is suspected, it could cause electric shock, fire, or rupture.	
 CAUTION	Consideration for children Children shall not play with the appliance.	
	Refrain from placing something on mechanical sections or insert hand at the inside. It could overheat, you could get hurt by the fan running at high speed.	
	Refrain from using inflammable spray, or placing combustible materials, nearby. If it ignites with sparks from switch, it could cause fire.	
Others		
 WARNING	Do not damage, process, bend forcibly, pull, or bundle the power cable. If it is damaged under heavy object, or by being pinched, it could cause fire, or electric shock.	
	When disconnecting a wire connector, hold the plug at the end. If it is pulled forcibly holding the wire, part of core wires may be broken, causing fire by overheat.	
	In the event of fire, "stop operation command from the equipment" shut down all power supplies. It could cause electric shock, or explosion. To extinguish fire, use "Oil fire extinguisher or electrical fire extinguisher".	
	Provide a secure foothold during servicing. Otherwise, it could cause injury if it collapses.	
	Check regularly the foundation frame for damage after using for a long period of time. If it is used without repair, it could cause injury if the condensing unit drops off.	
 CAUTION	Before cleaning or inspecting the equipment, turn the "ON/OFF" switch to "OFF" to shut down the power supply. Otherwise, you could get injured by the fan, or it could cause electric shock.	
	Do not mount or place something on the condensing unit. It could cause injury if you fall, damage the machine, or drop the object.	
	Refrain from touching hands on the gas cooler fin directly. You could get hurt.	

Instructions

Others		
 CAUTION	When washing the gas cooler, take care not to splash water directly over electric parts. It could cause failure on devices.	
	After washing the gas cooler, collect cleaning solution, and dispose after treating appropriately, or have it consigned to a specialized contractor for disposal.	
	Avoid touching exposed pipes, or wires. It could cause burns and electric shock.	
	Avoid touching highly heated sections. Compressor, condenser, or wiring could be heated up beyond 100°C locally, which could cause burns if touched.	
	Avoid touching electric parts, or operating switches, with wet hands. It could cause electric shock.	
	Regularly inspect the earth leakage breaker for proper operation. If it is defective and fails to trip when current leaks, it could cause electric shock, or fire.	
	When the unit is not used for a long period of time, turn off the source power supply.	

Repair, relocation and disposal		
 WARNING	No person other than repair personnel or specialized contractor should attempt to disassemble, repair, or modify the unit. Improper practice in disassembly, repair, or modification, could cause injury, electric shock, or fire, if it operates abnormally.	
	When it becomes necessary to relocate the unit, ask the work to your dealer, or specialized contractor. Imperfect installation could cause electric shock, or fire.	
	When releasing R744 refrigerant, choke the valve to release little by little, and direct it where no person is present. If it gets into eyes, you could lose eyesight. R744 in higher concentration can harm or suffocate. In the solid state, R744 is called generally as dry ice, which is very cold at -75°C under the atmospheric pressure. If it is touched by bare hand, it could cause frostbite.	

Relevant Standards and Directive

EN 378 -2: Refrigerating Systems And Heat Pumps-Safety And Environmental Requirements.

EN 60335-1: Household And Similar Electrical Appliances – Safety –Part 1: General Requirements

Low Voltage Directive n° 2014 / 35 / UE



Machinery Directive n° 2006 / 42 / CE

Pressure Equipment Directive (PED) no. 2014/68/EU

RoHS Directive 2011/65/EU

WEEE Directive 2012/19/EU

(Other local applicable standards)

Scroll-rotary type compressor		
 WARNING	Scroll-rotary compressor becomes very hot It is highly heated during and immediately after stop of operation. Special care must be taken during maintenance and service.	
	Oil is retained at the high pressure side of scroll-rotary compressor. Care must be taken particularly when charging or discharging oil during maintenance, service, or test run.	

Instructions

1 – Introduction

These instructions pertain to Optyma™ iCO₂ condensing units OP-UPAC030COP04E used for refrigeration applications. They provide necessary information regarding safety and proper usage of this product.

The condensing unit includes following:

- 2 Inverter Compressors (Scroll + Rotary)
- 2 parallel gas cooler (Coated fin and tube Heat exchanger)
- Unit controller
- 2 DC fan Assembly
- Receiver
- High pressure switch
- The condensing unit assembly is CE, PED certified CAT III
- This condensing unit controls its capacity by the speed control by means of inverter.
- Compressor is connected to the inverter, and operated at variable speed. The inverter changes the power supply frequency supplied to the compressor of which speed changes nearly proportional to this frequency. The capacity is controlled in this way.
- Whether the load is high or low it is judged by detecting the low pressure (LP) of compressor. If the low pressure (LP) is high, it is judged that the load is high so that the output capacity of condensing unit is increased.
- The speed control by inverter features that it allows to change the capacity.
- Since the inverter is in the advancing phase, if an advancing capacitor is installed, the power factor drops in reverse. Never install an advancing capacitor, because it may be broken.

Caution for avoiding noise problem:

1. Ground equipment always

- Use a dedicated grounding always. Grounding / earthing type TN system.
- Ground as close as possible to the refrigerating machine, with a cable as short as possible.

2. Separate lines of the power supply cable and the power cable of other devices.

3. Where the unit is installed close to a device that emits electromagnetic radiation, install it avoiding the radiating plane from being directed to the electric equipment box on the unit.

To prevent electromagnetic interference on other device

1. Inverter operation loads noise to the power cable, which could interfere with neighboring devices. Take care of following matters to prevent complaints on noise.

- Separate the refrigerating machine and power supply wiring from receiving devices more than 3 m.
- Pass the power supply cable through a metal pipe. Make sure to ground the pipe.
- Ground the refrigerating machine and the receiving devices individually and independently.

Instructions

2 – Handling and storage

	When the condensing unit is hoisted with ropes for delivery, take care to maintain the centre of gravity. It could drop off if the stability is lost.
	After completing the wiring work, test with a DC 500 V insulation resistance meter between terminals of electric part and ground, and confirm it detects 1 MΩ or more. However, do not measure the insulation resistance at the electronic circuit (DC circuit).
	High voltage is retained for a while (about 1 minute) owing to the residual charge after turning off the power supply of condensing unit. Do not touch electric parts till the LED on the inverter PCB extinguishes, because it is dangerous.

Delivery

- Determine the delivery route, and deliver the unit to the installation place without removing the packing.
- When hoisting the unit, use a pair of ropes and cushions to protect sections chafed by the ropes.

NOTE:

- Make sure to pass the ropes through square holes on the fixing legs of condensing unit.
- Protect surfaces of the condensing unit where the ropes are applied with wear plates or cushions.

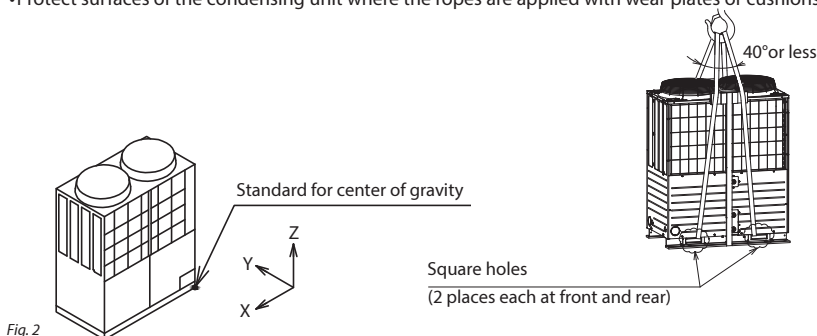

Fig. 2

- It is recommended not to open the packaging before the unit is at the final place for installation.
- Handle the unit with care. The packaging allows for the use of a forklift or pallet jack. Use appropriate and safe lifting equipment.
- Store and transport the unit in an upright position.
- Store the unit between -35°C and 50°C.
- Don't expose the packaging to rain or corrosive atmosphere.
- After unpacking, check that the unit is complete and undamaged.

Center of gravity position

Type	OP-UPAC030COP04E
Weight (kg)	448
X (mm)	636
Y (mm)	347
Z (mm)	575

3 – Installation precautions

	Do not braze as long the condensing unit is under pressure.
	Never place the unit in a flammable atmosphere
	Place the unit in such a way that it is not blocking or hindering walking areas, doors, windows or similar.

- Ensure adequate space around the unit for air circulation and to open panels. Refer to picture below for minimal values of distance to walls.
- Avoid installing the unit in locations which are daily exposed to direct sunshine for longer periods.
- Avoid installing the unit in aggressive and dusty environments.
- Ensure a foundation with horizontal surface (less than 3° slope), strong and stable enough to carry the entire unit weight and to eliminate vibrations and interference.
- The unit ambient temperature may not exceed 50 °C during off-cycle.
- Ensure that the power supply corresponds to the unit characteristics (see nameplate).
- Use clean and dehydrated refrigeration-grade copper tubes and silver alloy brazing material suitable for the Ps of the system..
- Use clean and dehydrated system components.
- Confirm that the strength and levelness of foundation can prevent vibration and noise.
- Fix the unit securely so that it will not be toppled by earthquake, or sudden gust of wind.

Installation Example	I	II	III
L1	800	800	800
L2	10	10	330
L3	800	500	800
L4	100(1)	500	100(2)
H1	1500	1500	1500
H2	Not limited	Not limited	Not limited
H3	1000	1000	1000
H4	Not limited	Not limited	Not limited
H5	2000	2000	2000

(1) Be sure to keep more than 100mm spaces when the unit contacts with a wall. If the unit installed in succession, 10mm spaces is enough.
(2) When pulling the power cable from the L2 side in succession installation, 300mm space is required.
(3) Be sure to keep enough service spaces of more than 800mm in front of the unit service panel for easy inspection of the unit and replacement of components (In case of Example II, for service space of back side 500mm or more are necessary).

Please refer page 53 for detailed information

Fig. 3

Instructions

- The installation in which the condensing unit is installed must comply to Pressure Equipment Directive (PED) no. 2014/68/EU. The Optyma iCO₂ condensing unit assembly (partially completed assembly) certified for PED by Notified body (Vincotte - notification number 0026).
 - It is recommended to install the unit on rubber grommets or vibration dampers (not supplied).
 - Slowly release the nitrogen holding charge through HP and MP and LP service port by each service valves is full opened. And remove the Caps on the end of Suction pipe and Liquid pipe.
 - Connect the unit to the system as soon as possible to avoid oil contamination from ambient moisture.
 - Avoid material entering into the system while cutting tubes. Never drill holes where burrs cannot be removed.
 - Braze with great care using state-of-the-art technique and vent piping with nitrogen gas flow.
 - Connect the required safety and control devices. When the schrader port is used for this, remove the internal valve.
 - It is recommended to insulate the suction pipe up to the compressor inlet with 19 mm thick insulation.
 - Copper piping material should comply with EN12735-1. And all pipe joints should comply with EN14276-2
 - At filed installation, support to added according to size and weight. Recommended maximum spacing for pipe support as per EN12735-1 & EN12735-2
- Connecting pipes shall be made before opening the valves to permit refrigerant to flow between the refrigerating system parts.

Design and practice the piping work as instructed below.

- Sufficiently wash the inside of low pressure device, pipes, etc., to remove dirt or moisture, and dry them before use. Use always a pipe cutter to cut refrigerant pipes, and blow off dirt with nitrogen, or air, before connection. (Avoid to use a saw, or grinder, because it could produce a lot of chips.)
- Use the nitrogen gas blow when brazing pipes to prevent oxide scale.
- Where the condensing units is positioned lower than the low pressure device, limit the level difference between them no larger than 5 m or, if it is positioned higher, no larger than 22 m. Length of piping between them needs to be no longer than 100 m. (When the level difference, or piping length, exceeds these standards, special measures may be required, such as the enlargement of pipe diameter.)

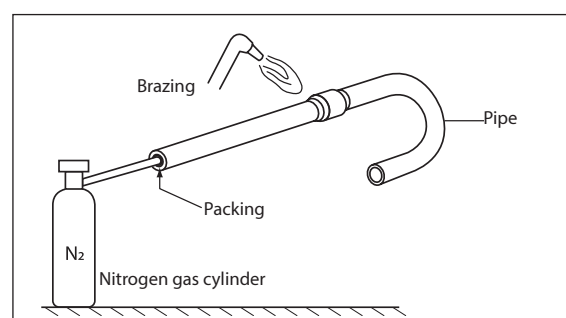

Fig. 4

Typical instillation

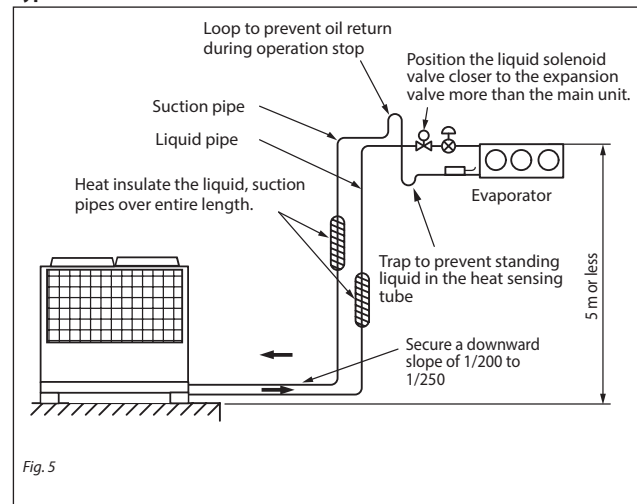

Fig. 5

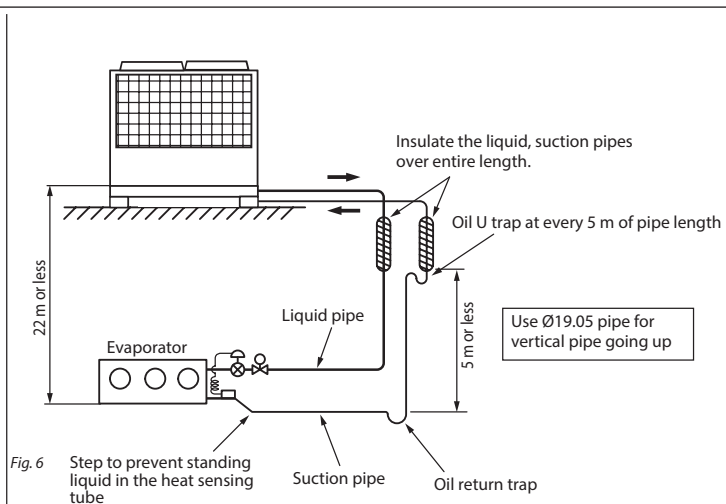

Fig. 6

- The suction piping connected to the compressor must be flexible in 3 dimensions to dampen vibrations. Furthermore piping has to be done in such a way that oil return for the compressor is ensured and the risk of liquid slug over in compressor is eliminated.
 - Take care to avoid direct contact between suction and liquid pipes without insulation material too large temperature difference.
 - The condensing unit is charged with Nitrogen gas at approx. 1.0 bar at shipping from the factory. Make sure to keep the seal intact till just before connecting pipes in order to keep out dirt or moisture. Release to the atmosphere must be made through service ports at the high, medium and low sides.
- *Dryer (accessory of refrigerant machine) is recommended to install in liquid pipe. Also strainer is recommended to install before the low pressure expansion valve.

Note on R744

	Refrigeration cycle pressures (airtight test pressure, operation pressure, etc.) become approx. 4 times larger than the same of R404A.
	Wall thickness of refrigerant pipes varies depending on the refrigerant and pipe size. Check if specified thickness is observed, and correct if necessary. It could vary depending on pipe materials as well.
	Ester oil is used as the condensing unit oil for the refrigeration cycle of R744.
	In order to avoid contamination with impurities such as moisture, dirt, etc., as much as possible, the same fundamental control as synthetic refrigerant is required at the installation of refrigerant piping.
	Practice thorough control on the storage and cutting of pipes to protect them from dirt or moisture.
Nitrogen blowing before brazing to prevent oxide scale.	

Instructions

4 – Installation

	Since the inverter is in the advancing phase, if an advancing capacitor is installed, the power factor drops in reverse. Never install an advancing capacitor, because it may be broken.
	Use a dedicated grounding always. Never use a common grounding with large power equipment such as a motor, or transformer. It should be avoided to connect to other simple grounding cable for prevention of electric shock only, or steel structure.
	Implement the D-type grounding (grounding resistance at 100 Ω or less).
	Ground as close as possible to the condensing unit, with a cable as short as possible.
	Separate lines of the power supply cable and the power cable of other devices.
Where the unit is installed close to a device that emits electromagnetic radiation, install it avoiding the radiating plane from being directed to the electric equipment box on the unit.	

4.1. Installation place (Select a place approved by the user.)

Selection of installation place

- Where air will be ventilated well.
- Sturdy foundation
- Where the suction inlet and outlet are free from obstructions.
- Where it will not be subjected to heat radiation from other heat source.
- Where the air outlet will not be blown with strong winds.
- Where the unit is not regulated strictly with respect to electric noise.
- Where drain water may be discharged.
- Where noise or hot air will not be nuisance to next door house.
- Where the unit will not be buried under snow.
- Where the unit is separated more than 5 m from TV or radio. (Where there is a potential electric interference.)

NOTE:

- a) Where two or more units are installed, secure sufficient suction spaces to prevent possible short-circuit in air flow particularly.
- b) Avoid to install where combustible gas could be leaked.
- c) When the unit is installed at a special place as follows, consult your dealer to prevent possible corrosion or failures.
 - Where corrosive gas generates (a spa).
 - Where it is exposed to salty winds (a coast).
 - Where it becomes smoky.
 - Near a machine that generates electromagnetic radiation.

Caution:

- Be sure to secure installation spaces.
- It could cause failures on the compressor or electric equipment owing to short-circuit in air flow.

*Device to be connected to low pressure side

Select and connect devices (show case, etc.) to be connected to the low pressure side of condensing unit according to the following table.

Item	Specifications
Number of connectable units	1 unit - 24 units
Load capacity	Determine the capacity of indoor units (show cases, etc.) connecting to the low pressure side of refrigeration unit, such that the total rated nominal capacities of these units, is over 50% and below 100% of the refrigeration unit's capacity
Minimum load during operation	If the load capacity remains low, the compressor of the condensing unit will start and stop frequently. It may cause the condensing unit to malfunction. The minimum load capacity of the connected load unit should be designed so that the compressors do not exceed 10 start/stop cycles per hour.
Module controller	Use specific module controllers and expansion valves recommended by Danfoss
Expansion valve	Select an appropriate diameter for electronic expansion valve. Recommended (Example) ... When 3 units of low pressure side devices are connected: AKV 10P4
Heat exchanger specifications	Select specifications with which the refrigerant flow speed in the heat exchanger piping is within the oil returnable range in the following figure.

Range of gas flow speed at the evaporator outlet during rated operation.

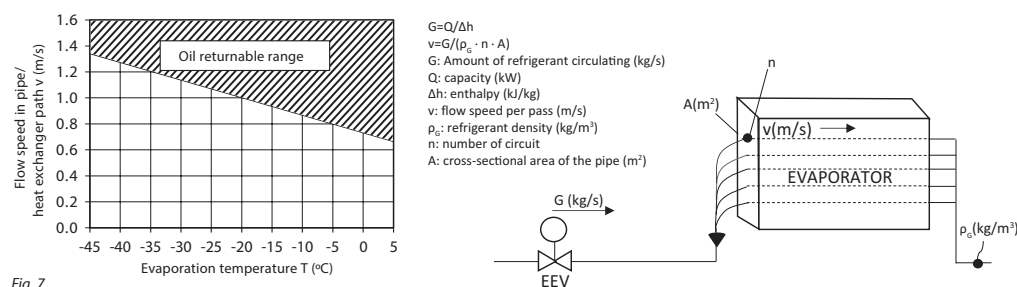

Fig. 7

Maximum liquid piping length from condensing unit to low pressure side devices.

For piping design and low pressure device selection, please check not to exceed maximum liquid piping length and total internal volume of low pressure device with following graph(*). Those show maximum liquid piping length which is evaluated with equivalent piping length with single diameter according to the equation in Section 6.4.3.4.

* Note: The purpose of following graph is to show the maximum length of liquid piping and maximum volume in the view point of system refrigerant mass. Those does not guarantee all low pressure device in indicated range of "Total volume of connected show case and unit cooler" can be operated.

Instructions

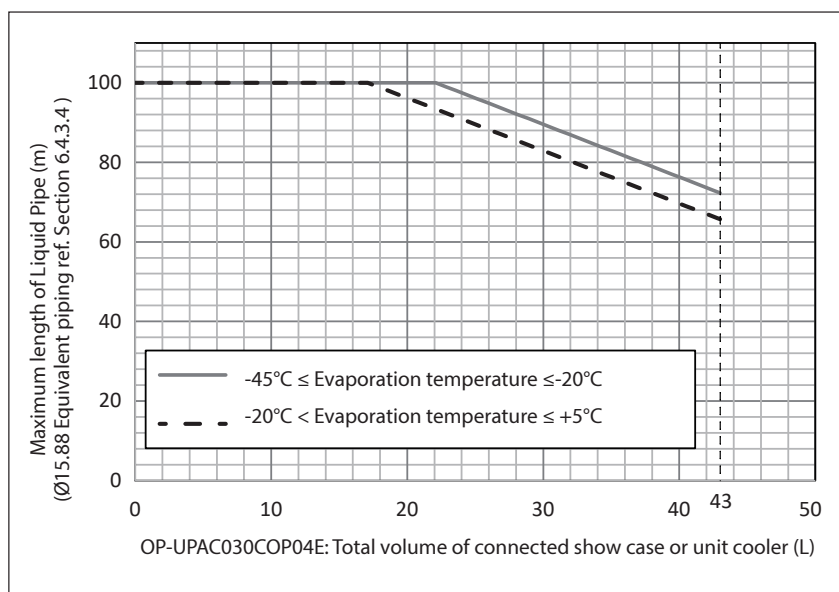

Fig. 8



Install the earth leakage breaker on the electric circuit to provide more safe protective function. It will prevent electric shock in the event of earth leakage.

Cleaning solution of gas cooler, or antifreeze solution, should not be disposed in a sewer, but disposed according to provisions of applicable laws. For details, consult your dealer or the customer service desk of maker.

4.2. Caution for installation of condensing unit

4.2.1. Anchor bolt position

• Make sure to fix the fixing legs of refrigerating machine with 4 pieces of anchor bolt (M10). Optimum height of bolt above the surface is 20 mm.

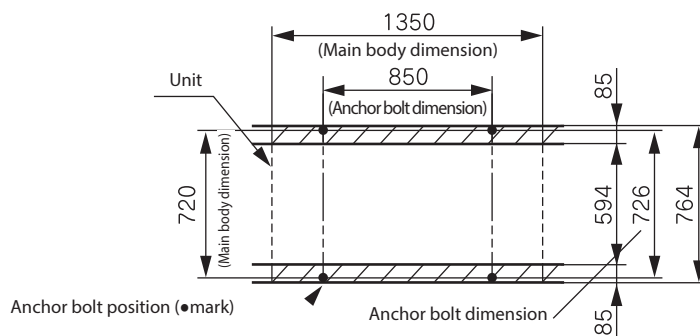

• All dimensions in mm unless specified

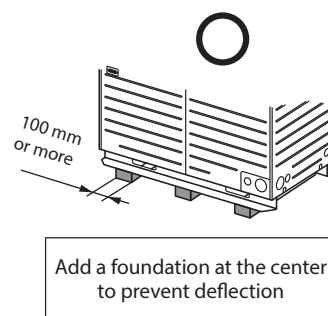
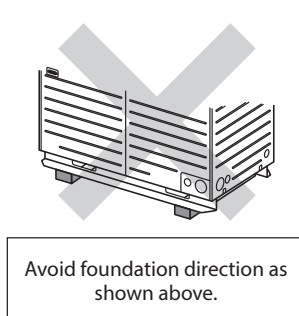
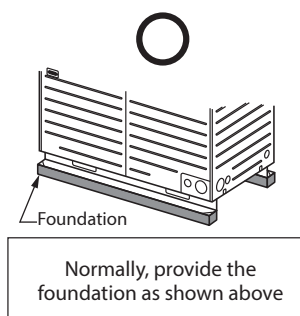

Fig. 9

Instructions

4.2.2. Foundation

- Confirm that the strength and levelness of foundation can prevent vibration and noise.
- The foundation must be larger than the shadowed areas in the above figures (larger than the front of the fixing legs of condensing unit).
- The foundation must run in the lateral direction of condensing unit as shown above (in the direction of the width of 1,350 mm).
- Fix the unit securely so that it will not be toppled by earthquake, or sudden gust.

4.2.3. Rubber cushion

- Size of rubber cushion must be able to support the entire bottom area of fixing leg. (See following figure.)

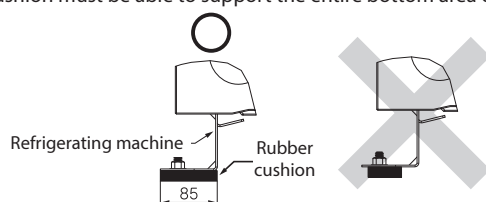

Fig. 10

NOTE:

- a) Install the cushion rubber such that it will support the entire bottom area of the fixing leg of condensing unit.
- b) It is prohibited that the bottom area of the fixing leg runs out the cushion rubber partially, or it is supported partially only by the cushion rubber.

4.2.4. Provision at snowy region

Provide following measures at snowy region not to bury the suction inlet, blow outlet, or the bottom of base plate, under snow.

1. Install the outdoor unit on a stand that is higher than expected surface of snow.
2. Install the unit under the eaves, or a snow roof (provided at site).

Instructions

4.3. Removing cushioning material and temporary bracket

After installation, to remove following cushioning material and temporary bracket from inside of refrigerating machine.

- (a) Cushioning cardboard between pipes
- (b) Cushioning cardboard between compressor and pipe
- (c) Temporary bracket on compressor base

4.4. To attach additional pipe insulation

(d) 2 pieces of pipe Insulation and 2 pieces of tape are implemented inside of panel with wrapped in a plastic package. There is bare pipe section (where (b) Cushioning cardboard between compressor and pipe had been existed) for each compressor, therefore to attach 1 pipe insulation on the section of bare pipe not to generate the clearance from upper (existing) insulation and to fix with them with 1 tape (to perform totally 2 times).

After insulation installation, compressor covers should be reinstalled as same as initial condition of first cabinet open.

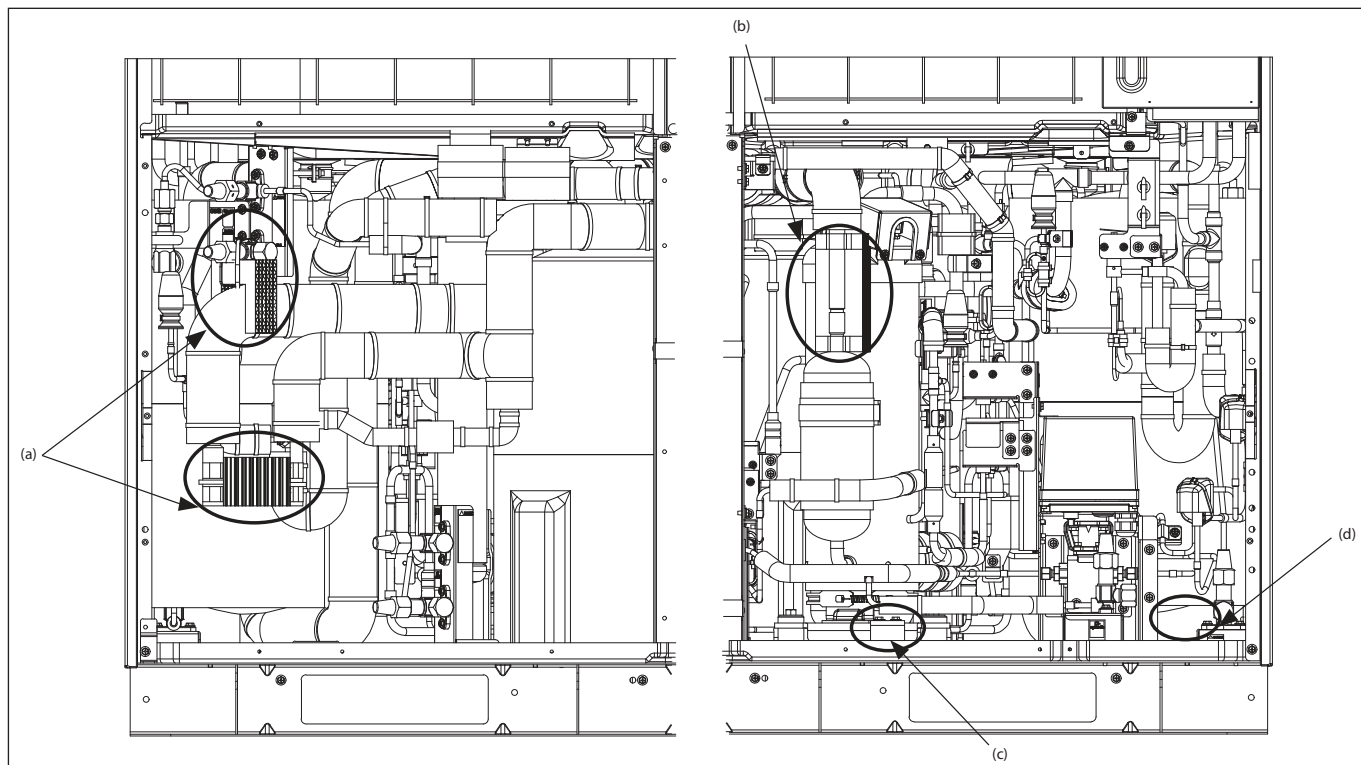

Fig. 11

Instructions

4.5. Piping work at site

4.5.1. Pipe diameter

Prepare refrigerant pipes at site. Pipe joints are as shown below.

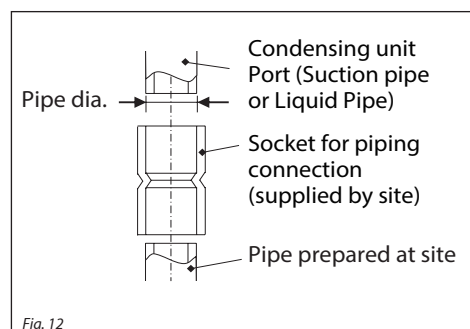

Fig. 12

Dimension

Type	Connecting pipe dia. (Example) (mm)	
	Suction pipe	Liquid pipe
OP-UPAC030COP04E	Ø25.40 (Brazing)	Ø15.88 (Brazing)

*Pipe wall thickness shows that of C1220T 1/2H.

4.5.2. Suction pipe

•Provide a downward slope (1/200 to 1/250) at the sidewise run of suction pipe. To return lubrication oil smoothly, do not provide a trap at the sidewise run section. Where heights differ larger than 5 m between the condensing unit and the low pressure device, provide a small trap.

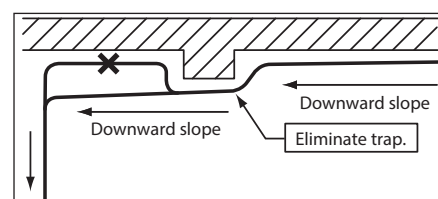

Fig. 13

4.5.3. Liquid piping

•Install the liquid solenoid valve just before the expansion valve.
•If the liquid feed piping is overheated by the effect of other heat source, it generates flash gas, reducing the cooling capacity. Run the liquid feed piping at a place as cool as possible. Where it passes at a place at high temperature by any chance, insulate it.

General recommendation

Select pipes PS 80 bar. Ensure with your supplier that pipe material can support bending keeping PS 80 bar or use fittings.

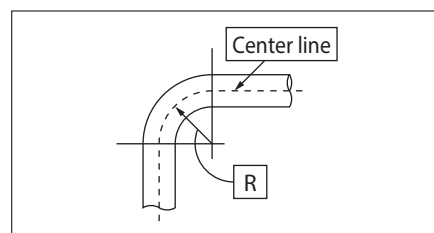

Fig. 14

Note for R744 (CO₂)

Since R744 (CO₂) may corrode metals if it solves into water, becoming weakly acidic, it is necessary to dry sufficiently by the vacuum drying.

	Start evacuation from the low pressure side to prevent the reverse phase on the compressor.
	Vacuum 4 hours to 0.67 mbar.
	Use a vacuum pump with a higher exhaust speed. (Conventional small pumps with exhaust speed of 20 to 30 l/min, which are in use widely, will take too much time.)
	Install a vacuum pump adaptor to prevent oil from returning from the pump to the refrigeration cycle.
	Use a manifold valve and a charge hose special to R744 (CO ₂).
	A joint (Reducer) to install on the service valve is included in the accessories. When performing the airtight test or vacuuming, finish the connection form of the joint according to purposes.
	When the degree of vacuum rises, presence of moisture, or leaks, is suspected. Check for moisture, or leaks. (Special vacuum dry)
	i. Vacuum dry (1st). ii. Vacuum dry (1st). : Pressurize nitrogen gas to 0.5 bar, and charge. Use nitrogen always. iii. Vacuum dry (2nd). iv. Ultimate vacuum must be maintained at -1 bar after letting it alone. If it is not, repeat the vacuum dry and vacuum break.

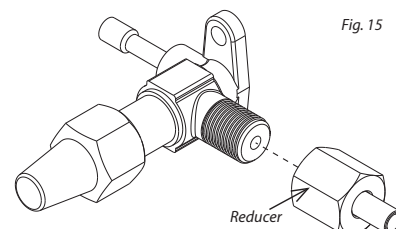

Fig. 15

Instructions

5 – Pressure test

- Make pressure test on pipe work at 1.1 x PS.
- The condensing unit itself doesn't need to be pressure tested because it has been already done in factory.
- Remove safety valve protecting evaporator. Don't forget to put them back again on circuit before leak test.

5.1 Leak detection



Never pressurize the circuit with oxygen or dry air. This could cause fire or explosion.

- Do not use dye for leak detection.
- Perform a leak detection test on the complete system.
- When a leak is discovered, repair the leak and repeat the leak detection.

5.2. Airtight test

5.2.1. Outline

- When the refrigeration cycle has been completed, test for airtightness on the entire equipment before heat insulating the piping. Airtight test pressure at installation is 80 bar at the high, medium and low pressure sides.
- Charge nitrogen gas from the service port and oil service port at the high pressure side. At the medium and low pressure sides, charge the gas from the service port at the medium pressure side and the service port at the low pressure side. Charge the gas in the order from the high to low pressure side.

5.2.2. Opening and closing of solenoid valve and expansion valve

- When the power is not supplied to the unit during the airtight test: Remove the coil from the medium pressure suction solenoid valve (SV-INJ), and open it forcibly using a special magnet
- When the power is supplied to the unit at the airtight test. Turn the dip switch SW5-7 to ON (*). All of the solenoid and expansion valves open so that the forcible opening is not necessary.

(* Operating method of dipswitch 5-7

1 Turn the dipswitch to ON when the power supply is turned OFF.

2 Turn the power ON.

3 Turn SW5-7 to OFF (down) upon completion of test. (Power may be turned ON.)

5.2.3. Test method

- Do not pressurize to specified pressure all at once, but raise it gradually.
- Stop the pressurizing at each step of 10 bar, 30 bar and 70 bar, and leave it alone to see if the pressure drops.
- Raise then the pressure to the design pressure, and record the ambient temperature and the pressure.

Apply a foam liquid over the surface. If no foam generates, it passes the test. It passes the test also if the pressure does not drop after leaving it alone for approx. a day under the specified pressure.

It is necessary to apply correction for ambient temperature variation.

Example for 1 K (Kelvin) Ambient Temperature difference:

T1=20°C = 293K; (20 +273K)

T2=21°C = 294K; (21 +273K)

PT1=80,0 bar; PT2=?

PT2 = PT1*T2/T1 = 80.0bar*294K/293K = 80.3bar

Therefore, 1K temperature difference can cause a 0.3 bar pressure difference.

$$\text{Absolute pressure at measurement} = \text{Absolute pressure at pressuring} \times \frac{(273^{\circ}\text{C} + \text{Temperature at measurement})}{(273^{\circ}\text{C} + \text{Temperature at pressuring})}$$

Absolute pressure = Gauge pressure + 1.0133 (bar)

(Gauge pressure is the pressure indicated on the manifold.)

If the pressure drops, it leaks at some places. Find and repair the leak spots.

When it leaks, check welded section and screwed section using foaming liquid.

5.2.4. Work sequence

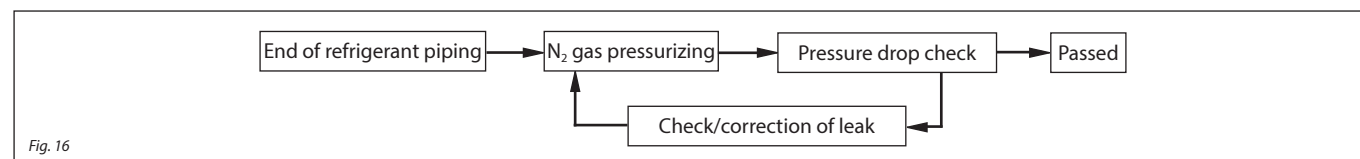

Fig. 16

Note

High, medium and low pressures of this unit are displayed at the 7-segment indicator on the control PCB. They are not displayed when the power supply is turned off. In such occasion, check them by installing a gauge manifold at the service ports of high, medium and low pressure sides.

(For the location of service ports, see the following figure.)

When venting the gas, start from the low pressure side. (Take care not to make the low pressure side of compressor higher than the high pressure side.)

Instructions

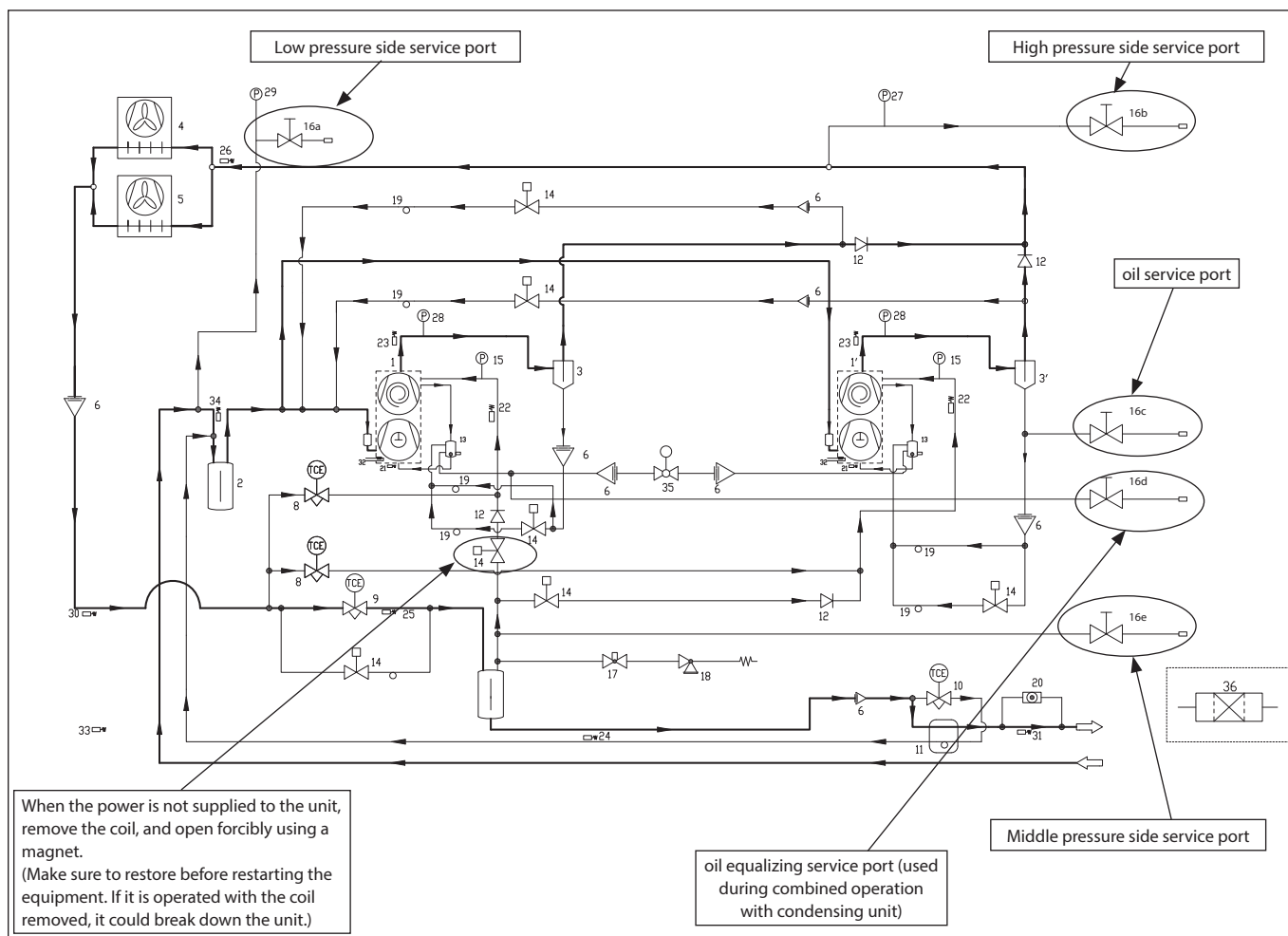

Fig. 17

6 - Vacuum dehydration

- Never use the compressor to evacuate the system.
- Connect a vacuum pump to both the LP & HP sides for quicker and efficient evacuation.
- Pull down the system under a vacuum of 500 $\mu\text{m Hg}$ (0.67 mbar) absolute.
- Do not use a megohmmeter or apply power to the compressor while it is under vacuum as this may cause internal damage.
- After the airtight test, connect the vacuum pump to the low pressure side service port and high pressure side service port, and evacuate (refer fig. 17).
- Use always a vacuum pump to the equipment.
- Check the low pressure with the gauge manifold or vacuum gauge.
- When the unit is not energized, remove the coil from the medium pressure suction solenoid valve, and open it forcibly using a special magnet.
- When the unit is energized, turn the dip switch SW5-7 to ON (Up) to turn on the unit's power supply. The electronic expansion valve and solenoid valve in the unit open. The vacuum pump is connected to the low pressure side only at that time.

6.1. Charge of condensing unit oil

- On the way of vacuuming, refill condensing unit oil from the service port.
- When the unit is not energized, remove coils from the hot gas bypass solenoid valve and oil return solenoid valve, and open the solenoid valve forcibly using a special magnet.
- When the unit is energized, turn off the unit's power supply, turn the dip switch SW5-7 to ON (Up), and turn the power ON. The electronic expansion valve and solenoid valve in the unit open. Make sure to turn SW5-7 to OFF (Down) when the work is over. The vacuum pump is connected to the service port at the low pressure side only at that time.
- In the event that the pipe is long or there is an oil sump in the evaporator, the condensing unit oil retained in the compressor becomes insufficient. Charge additional condensing unit oil according to Section 6.2.
- After charging the additional oil, confirm that 7-segment display "C32 (Level switch)" indicates "1 (With oil)". When the oil is insufficient, it indicates "0". (After stopping the freezing operation, for example, the oil level may turn to "0" temporarily because of the pressure difference in the compressor. If it indicates "0" continually while the compressor is running, refill additional oil.)
When the left 3 of 7-segment shows C32, the third digit from the right indicates the OLS1-2 status.
- If the condensing unit oil becomes insufficient during operation, tripping OLS1-2, the oil level alarm "oPE-88" or oil level error "E88-1" is indicated on 7-segment display. (Dip switch SW6-5 OFF is for Alarm or ON for Error.) When the alarm or error occurs, refill additional condensing unit oil.
- Time of oil level low with OLS1-2 during compressor running can be summed and checked with 7-segment display "C42", which displays "Accumulated time of CM1 ON and OLS1-2 OFF".
- As well, tripping OLS2-2, oil level alarm "oPE-88" or oil level error "E88-2" is indicated.

Instructions

6.2. Calculation of the charge quantity of condensing unit oil

Use the following equation.

$$\text{Condensing unit oil quantity (cm}^3\text{)} = \text{Standard condensing unit oil quantity} * 1 \text{ (cm}^3\text{)} + \text{Piping condensing unit oil quantity} * 2 \text{ (cm}^3\text{)}$$

(*1) Standard condensing unit oil quantity (Charged at the shipment from factory.)

	Diamond Freeze MA68
Condensing unit oil initial charge quantity	4800cc

(*2) Piping condensing unit oil quantity

• This is calculated based on the specifications of connecting gas pipe (pipe size) and the length of each pipe. Where no branching pipe is used, take the length of pipe to the farthest low pressure device as the pipe length. Where it is used, take the sum of the length of pipe to the pipe joint of farthest low pressure device from first branching and the length of pipe to the pipe joint of second farthest device as the pipe length. Example of calculation where there are branch pipes is as shown below.

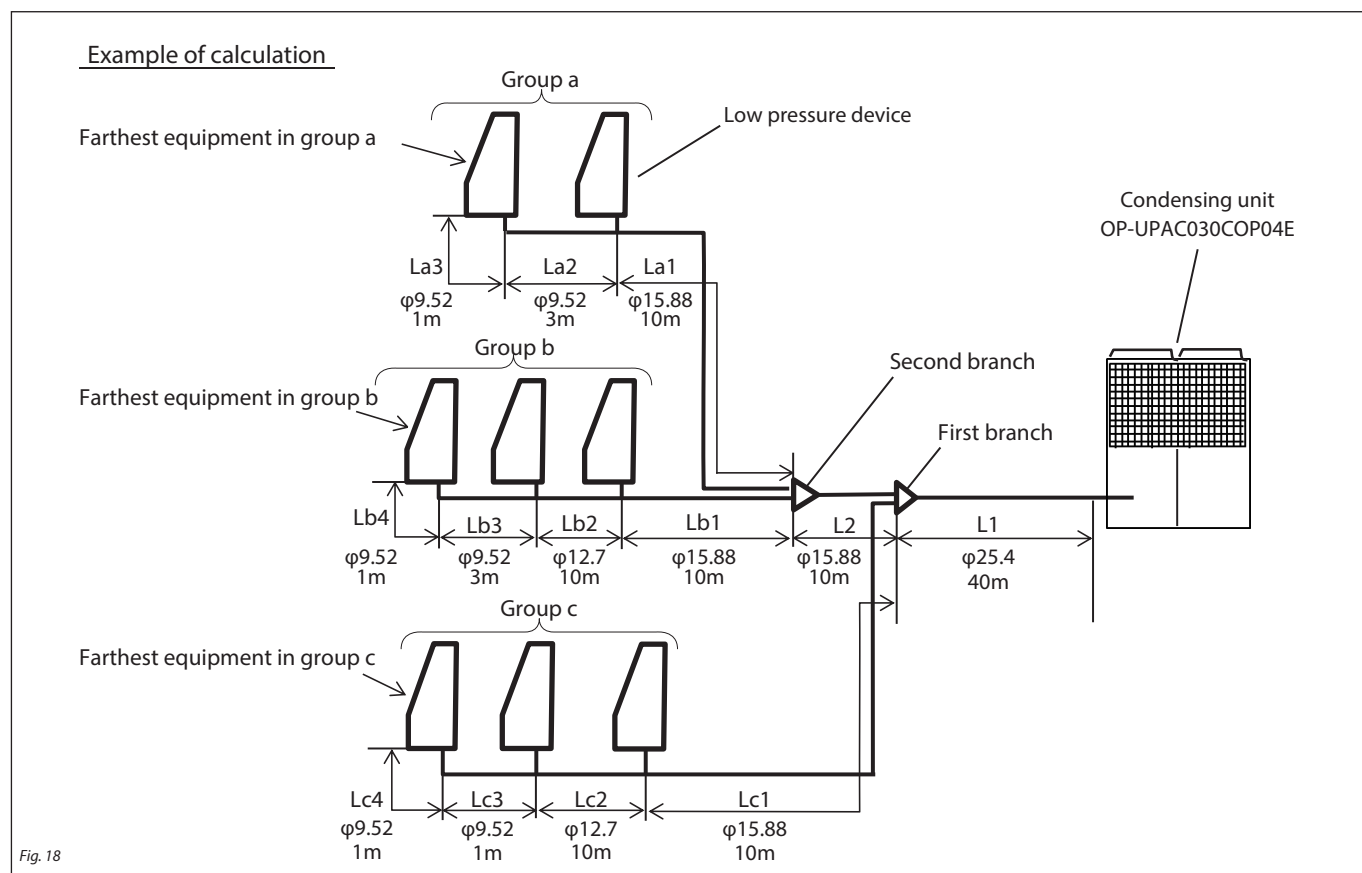

Instructions

•Items necessary to calculate the oil quantity vary depending on the distance to the farthest length from first branch.

Farthest in group a: $LA = L2 + La1 + La2 + La3$

Farthest in group b: $LB = L2 + Lb1 + Lb2 + Lb3 + Lb4$

Farthest in group c: $LC = Lc1 + Lc2 + Lc3 + Lc4$

Where $LB > LC > LA$, LB is selected as the longest pipe.

The second longest pipe:

Farthest in group a (from Second branch): $LA' = La1 + La2 + La3$

Farthest in group c (from First branch): $LC = Lc1 + Lc2 + Lc3 + Lc4$

Where $LC > LA'$, LC is selected as the second longest pipe.

Then, to calculate the piping oil quantity with L1, LB and LC in this case.

Sum up the oil quantity for each piping as "Piping condensing unit oil quantity". The oil quantity per unit length is different for each pipe size. Reference value is shown in following table of "Oil quantity/m of refrigerant pipe (gas pipe)".

•Piping condensing unit oil quantity = (Oil quantity/unit length of L1 pipe) x L1 (m) + (Oil quantity/unit length of L2 pipe) x L2 (m)
 + (Oil quantity/unit length of Lb1 pipe) x Lb1 (m) + (Oil quantity/unit length of Lb2 pipe) x Lb2 (m)
 + (Oil quantity/unit length of Lb3 pipe) x Lb3 (m) + (Oil quantity/unit length of Lb4 pipe) x Lb4 (m)
 + (Oil quantity/unit length of Lc1 pipe) x Lc1 (m) + (Oil quantity/unit length of Lc2 pipe) x Lc2 (m)
 + (Oil quantity/unit length of Lc3 pipe) x Lc3 (m) + (Oil quantity/unit length of Lc4 pipe) x Lc4 (m) (a)

Oil quantity/m of refrigerant pipe (gas pipe)						
Refrigerant pipe size x Wall thickness (For material: C1220 1/2H)	Ø6.35x0.5	Ø9.52x0.8	Ø12.7x1.0	Ø15.88x1.2	Ø19.05x1.4	Ø25.4x1.8
Charge quantity (cc/m)	3	5	7	11	16	39

•Calculate the piping condensing unit oil quantity from the equation (a) above.

Piping refrigerating oil quantity = $39 \times 40 + 11 \times 10 + 11 \times 10 + 7 \times 10 + 5 \times 3 + 5 \times 1 + 11 \times 10 + 10 \times 7 + 5 \times 1 + 5 \times 1 = 2060 \text{ cc}$

3 Additional condensing unit oil quantity

Additional condensing unit oil is calculated to be 2060cc from 2. Round up the oil quantity calculated with 2 by the unit of 100 cc.

If the piping refrigerating unit oil calculated with (*2) is less than 780 cc ($39 \text{ cc/m} \times 20 \text{ m}$), it is not necessary to add the piping oil quantity.

In case that piping refrigerating machine oil quantity, which is calculated from (*2), is more than 780 cc, to add the amount of increment from 780 cc.

Total condensing unit oil in the system becomes $4800 \text{ cc} + 2100 \text{ cc} - 780 = 6120 \text{ cc}$ from 1, 2 and 3.

4 Maximum refrigerant machine oil quantity.

Maximum refrigerant machine oil quantity is different by equivalent pipe length. Below equation shows calculation of Ø25.4 equivalent pipe length and below graph shows maximum refrigerant machine oil quantity for each Ø25.4 equivalent pipe length.

$$\Phi 25.4 \text{ equivalent pipe length} = \text{Piping refrigerating oil quantity}(\text{cc}) / 39(\text{cc/m})$$

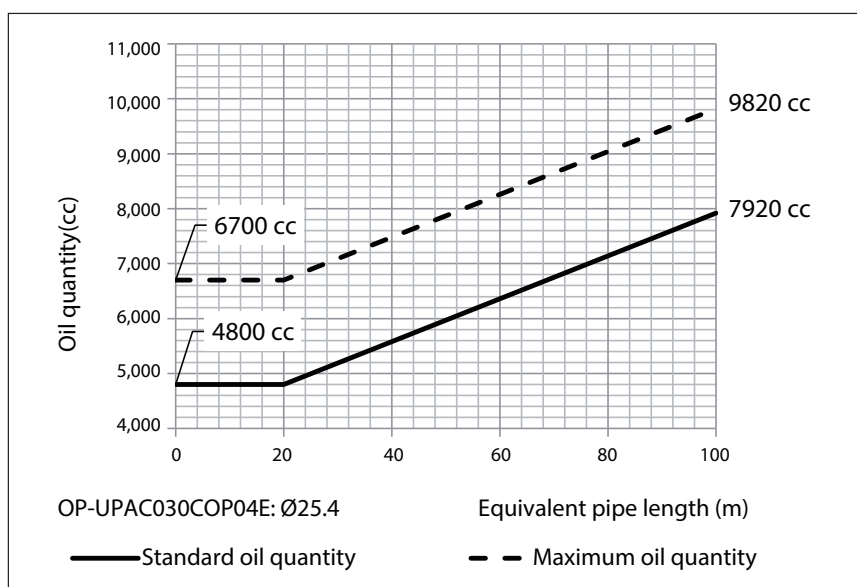
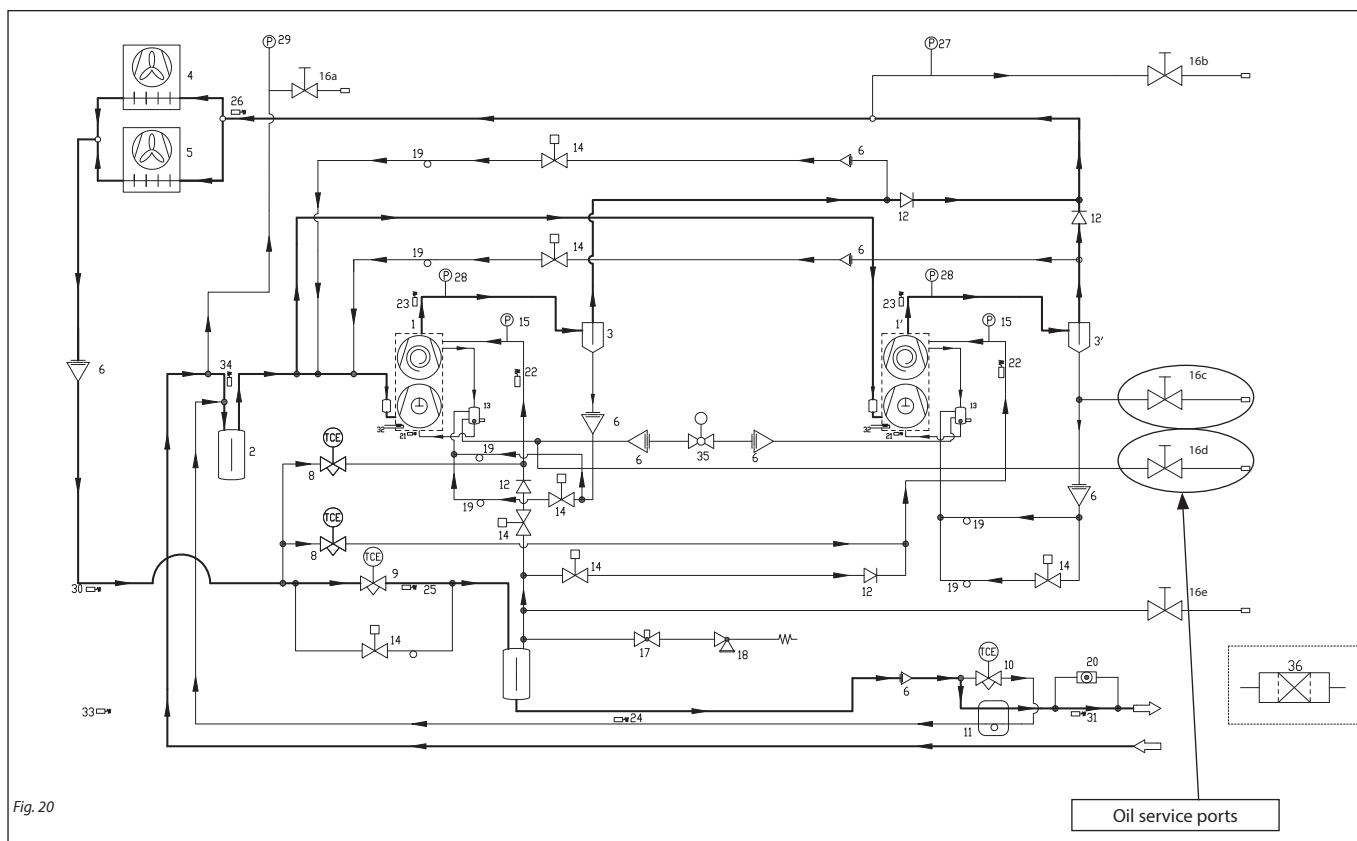

Fig. 19

Instructions



Caution for installation

1. Time to open up the condensing unit oil to the atmosphere should be as short as possible.
2. Use up the condensing unit oil for replenishment. Once oil container is opened, it should be used entirely and should not be stored for future use.
3. Ambient temperature at storage should be no higher than 40°C, and avoid places where it is exposed to direct sunlight or temperatures change widely.
4. The oil become colorless and transparent.
5. Since the unit inside becomes in the state of vacuum during the replenishment of condensing unit oil, pay utmost attention not to introduce air.
6. Please note that a special device (manual pump) is required when condensing unit oil is charged after operating the unit,
7. Dispose of the condensing unit oil and container after opening according to the regulations of each country.

Instructions

6.3. Replenishment of condensing unit oil after operation

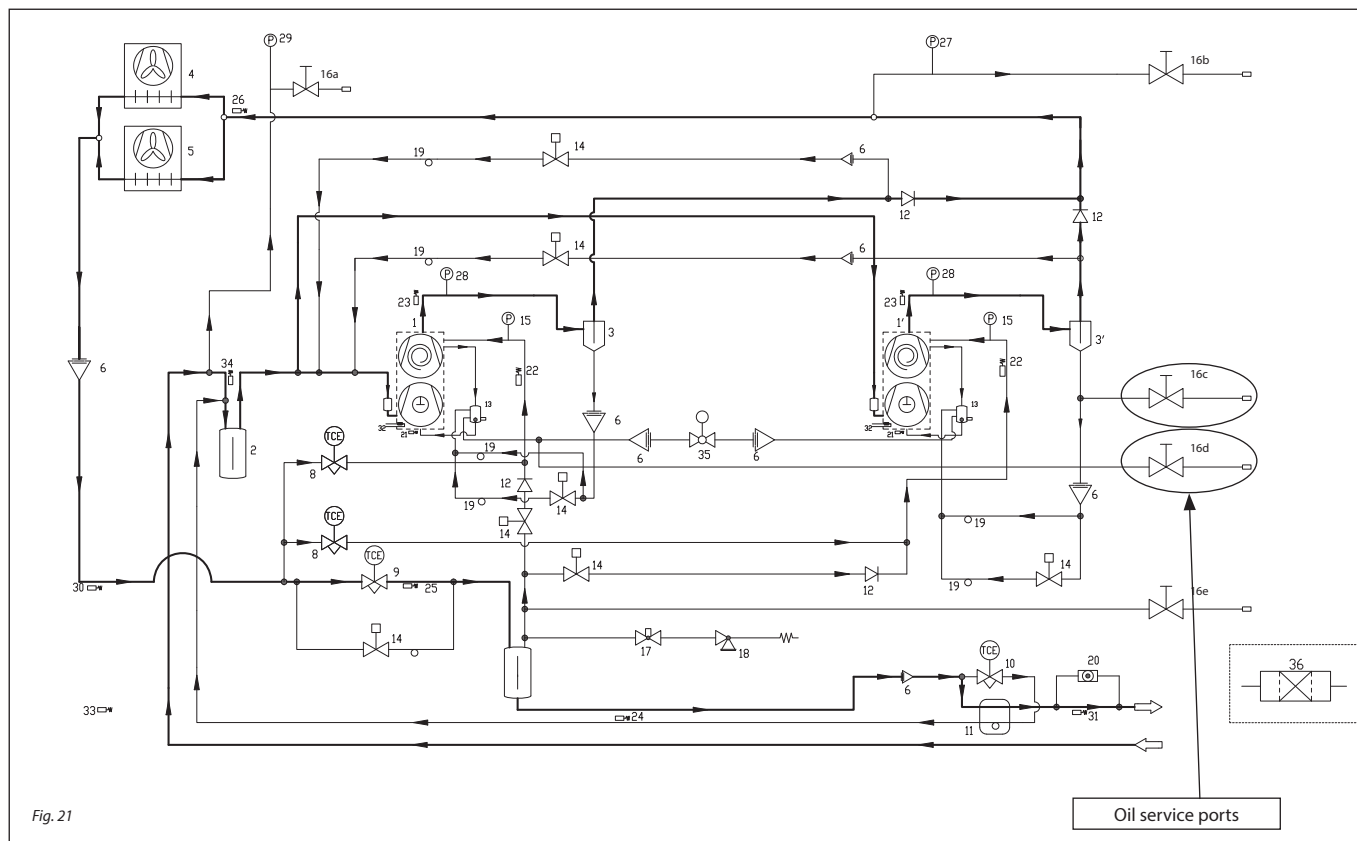

Fig. 21

Note:

Entire compressor becomes very hot and under high pressure immediately after operation. Handle it with utmost care.

1. Stop the unit.
2. Connect the manual pump and the unit with a charging pressure hose (for CO₂).
* Before connecting the pressure hose, confirm that the valve at the oil service port is closed.
3. Compress condensing unit oil with the manual pump. When the pressure becomes higher than the balance pressure, open the valve at the oil service port, and charge the condensing unit oil.
4. After charging oil, close the valve at the oil service port, and remove the charging pressure hose (for CO₂).
5. Operating the unit, check the oil level in the oil pod.

6.4. Refrigerant charge

After vacuuming and charging the condensing unit oil, charge the refrigerant as follows.

- Use a refrigerant grade 4.5, 5 ppm of water, purity 99.995%.

6.4.1. Weight check of refrigerant cylinder

- Use a weight whenever the refrigerant is charged, and charge in the specified quantity as calculated with the following equation.

6.4.2. Calculation of refrigerant charge quantity

Calculate the charge quantity with the following equation.

Refrigerant charge quantity (kg) = Standard refrigerant quantity of condensing unit + Refrigerant quantity for show case or unit cooler + Piping refrigerant quantity.

Regarding these refrigerant quantities, refer to 6.4.3.1, 6.4.3.2 and 6.4.3.3.

6.4.3 Standard refrigerant quantity of condensing unit

6.4.3.1 Standard refrigerant quantity of condensing unit

Standard refrigerant quantity of condensing unit (kg)	
Evaporation temperature setting ≤ -20°C	-20°C < Evaporation temperature setting ≤ +5°C
11.7	15.7

Instructions

6.4.3.2 Refrigerant quantity for connected show case or unit cooler

Check the total capacity (ℓ) of show cases and unit coolers to be connected. Calculate the charge quantity by multiplying the refrigerant charge rate.

Refrigerant of show cases or unit coolers to be connected = Total capacity of show cases or unit coolers to be connected (ℓ) x Refrigerant charge rate

* Refrigerant charge rate of show cases or unit coolers: 0.2 (kg/ℓ)

6.4.3.3 Piping refrigerant charge quantity

Piping refrigerant charge quantity is calculated from the specifications of liquid pipe of connecting pipe (pipe size) and the length of each pipe.

Piping refrigerant charge quantity (kg) = Additional charge quantity/m of Ø6.35 (kg/m) x L1 + Additional charge quantity/m of Ø9.52 (kg/m) x L2 + Additional charge quantity/m of Ø12.7 (kg/m) x L3 + Additional charge quantity/m of Ø15.88 (kg/m) x L4 + Additional charge quantity/m of Ø19.05 (kg/m) x L5

L1: Total length of Ø6.35 (m), L2: Total length of Ø9.52 (m), L3: Total length of Ø12.7 (m), L4: Total length of Ø15.88 (m), L5: Total length of Ø19.05 (m)

6.4.3.4 Calculation of the equivalent piping length with size Ø15.88 as following equation based on Piping refrigerant quantity

Leq :Ø15.88 equivalent pipe length (m) = Piping refrigerant quantity (kg) / 0.155 (kg/m)

6.4.3.5 Check the whether Leq equivalent piping length from (6.4.3.4) is same or less than maximum length of liquid pipe with the total volume of connected show case or unit cooler.

Maximum length of Liquid pipe is following Y-axis in following graph.

6.4.3.6 Correction of the Piping refrigerant charge quantity

As per the Ø15.88 equivalent pipe length (hereafter Leq), piping refrigerant charge quantity (kg) need to be corrected.

a) Leq > 20m : To correct additional charge quantity from 0.155kg/m to 0.151kg/m in the section of increment Leq from 20m.

Corrected piping refrigerant quantity = 0.155(kg/m) × 20(m) + 0.151(kg/m) × (Leq (m) - 20(m))

b) Leq ≤ 20m : No correction is necessary. Corrected piping refrigerant charge quantity (kg) is same value of 6.4.3.6

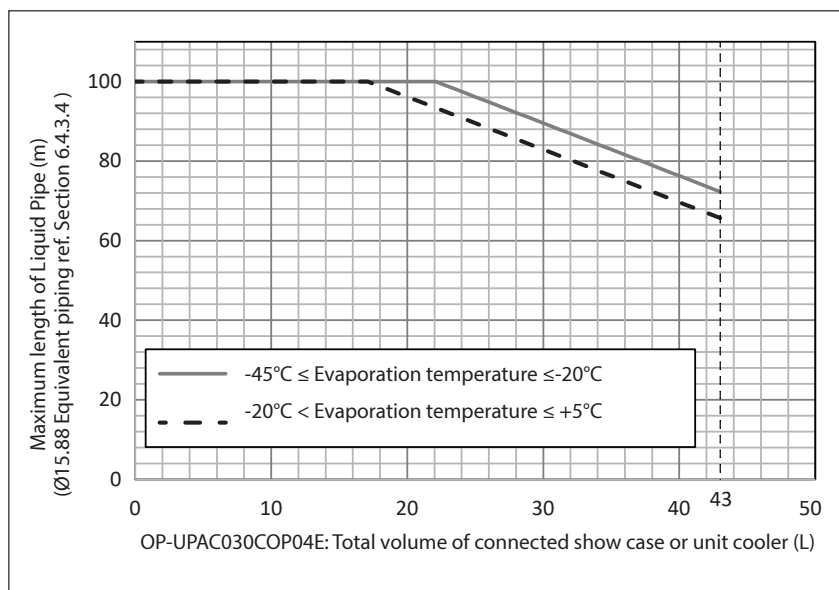

Fig. 22

6.4.4. Maximum refrigerant charge quantity

Confirm that the refrigerant charge quantity as calculated in the step 6.4.3.6 is not larger than the maximum refrigerant charge quantity. Maximum refrigerant charge quantity is the limit value to be charged in system.

Unit	Maximum refrigerant charge quantity	
	Evaporation temperature setting ≤ -20°C	-20°C < Evaporation temperature setting ≤ +5°C
OP-UPAC030COP04E	31kg	34kg

(i) Sum up with 6.4.3.1 Standard refrigerant quantity of condensing unit, 6.4.3.2 Refrigerant quantity for connected show case or unit cooler and 6.4.3.6 Corrected piping refrigerant charge quantity as "Refrigerant charge quantity".

Refrigerant charge quantity (kg) = Standard refrigerant quantity (kg) + Refrigerant quantity for connected show case or unit cooler (kg) + Corrected piping refrigerant quantity (kg)

When Refrigerant charge quantity calculated in the step 6.4.4.(i) < Maximum refrigerant quantity, charge the refrigerant in the quantity calculated in the step 6.4.4.(i).

When Refrigerant charge quantity calculated in the step 6.4.4.(i) ≥ Maximum refrigerant charge quantity, charge the refrigerant in the maximum refrigerant charge quantity.

Instructions

6.4.5. Example of calculation – Determination of refrigerant charge quantity

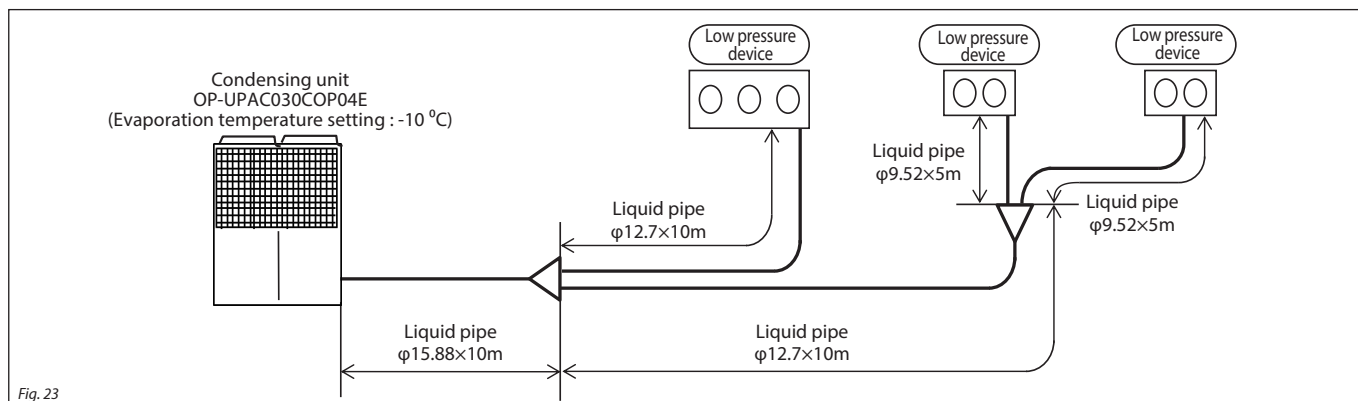

In case of the piping system as above, the piping refrigerant charge quantity becomes 6.3 kg from the following calculation.

$$\text{Piping refrigerant quantity} = 0.155 \text{ (kg/m)} \times 10 \text{ (m)} + 0.098 \text{ (kg/m)} \times (10 \text{ (m)} + 10 \text{ (m)}) + 0.054 \text{ (kg/m)} \times (5 \text{ (m)} + 5 \text{ (m)}) = 4.05 \text{ kg} \dots\dots\dots \text{(a)}$$

Additional charge quantity/m of refrigerant pipe (Liquid feed pipe)					
Refrigerant pipe size x Wall thickness (For material: C1220 1/2H)	Ø6.35x0.5	Ø9.52x0.8	Ø12.7x1.0	Ø15.88x1.2	Ø19.05x1.4
Additional charge quantity (kg/m)	0.025	0.054	0.098	0.155	0.225

In addition, Ø15.88 equivalent pipe length is calculated to confirm that the refrigerant charge quantity is smaller than the maximum refrigerant charge quantity.

$$\text{Ø15.88 equivalent pipe length} = \text{Piping refrigerant quantity (ℓ)} / 0.155 = 26.1 \text{ (m)} \dots\dots\dots \text{(b)}$$

Check the equivalent pipe length: 26.1 (m) is longer than 20m.

$$\text{Thus, Corrected piping refrigerant quantity} = 0.155 \text{ (kg/m)} \times 20 \text{ (m)} + 0.151 \text{ (kg/m)} \times (26.1 \text{ (m)} - 20 \text{ (m)}) = 4.02 \text{ (kg)}$$

Calculate the refrigerant charge quantity for when total capacity of connected unit coolers is 21 (ℓ).

$$\text{Refrigerant charge quantity} = 15.7 \text{ (kg)} + 21 \text{ (ℓ)} \times 0.2 \text{ (kg/ℓ)} + 4.02 \text{ (kg)} = 23.9 \text{ (kg)} \dots\dots\dots \text{(c)}$$

Since the refrigerant charge quantity (c) : 23.9kg is the smaller than the value of the maximum refrigerant charge quantity 34kg, 23.9kg is taken as refrigerant charge quantity. (When Calculated refrigerant charge quantity ≥ Maximum refrigerant quantity, charge in the maximum refrigerant quantity.)

6.4.6. Refrigerant charge when compressor not running

- Charge liquid refrigerant
- Charge must be done through medium service port.
- Charge first in vapor phase to pressure 7 - 10 bar to break the vacuum.
- When the unit is energized, turn off the unit's power supply. Turn the dip switch SW5-7 to ON (Up) and turn ON the unit's power supply. All electronic expansion valves, solenoid valves and oil equalizer electric ball valve in the unit will be opened. When the work is over, turn the dip switch SW5-7 to OFF (Down).

6.4.7. Refrigerant charge in the cycle when the compressor is running

- While the compressor is running, charge liquid refrigerant from the low pressure side service port. Open the valve on the cylinder gradually after operating the compressor. (Don't open the valve quickly. It could cause liquid back, resulting in failures on the unit.)

Note:

Overcharge of refrigerant could cause the liquid back from the medium pressure receiver. While the condensing unit is operating, take care to avoid the degree of superheat of under-dome (under-dome temperature - saturation temperature of medium pressure sensor) becomes lower than 10 deg.

Instructions

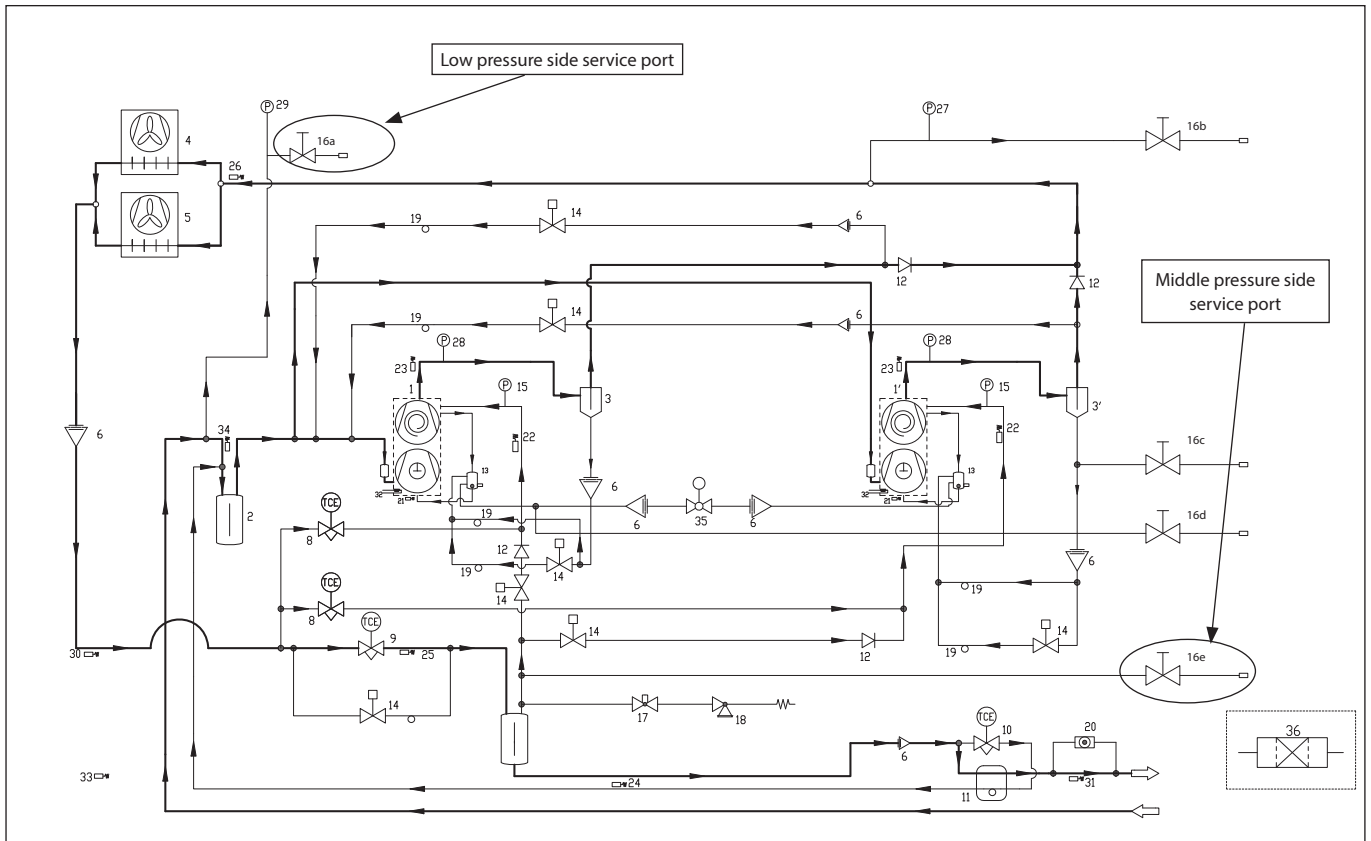

Fig. 24

Note on R744 (CO₂):

R744 (CO₂) uses pressures higher than equipment based on Freon. Sufficient care must be taken when charging the gas.

Caution for work

1. Charge in liquid phase after breaking the vacuum at 7 or 10 bar.
2. Confirm that it is contained in a cylinder special to R744 (CO₂).
3. Use the manifold valve and the charge hose special to R744 (CO₂).
4. Show a warning sign board stating "High pressure gas charge" at a place where it can be seen by people. (When the charging place can be approached from more than one place, show the board at respective places.)
5. Even when the charge pressure dropped in the cylinder, never heat the cylinder higher than 40°C for reason of security.
6. Do not lay flat the cylinder during charging.

Instructions

7 – Electrical connections

- Switch off and isolate the main power supply.
- Ensure that power supply can not be switched on during installation.
- All electrical components must be selected as per local standards and unit requirements.
- Refer to wiring diagram for electrical connections details.
- Ensure that the power supply corresponds to the unit characteristics and that the power supply is stable (nominal voltage $\pm 10\%$ and nominal frequency $\pm 2,5$ Hz).
- Dimension the power supply cables according to unit data for voltage and current.
- Make the power supply according to local standards and legal requirements.
- The unit is equipped with high pressure switches, which directly cut the power supply to the compressor in case of activation. Parameters for high pressure cut outs are preset in the controller, adapted to the compressor installed in the unit.

Wiring capacity

Electrical work must be done by qualified technicians.

Electrical installation work must be executed according to the technical standards and other regulations applicable to electrical installations in the country.



Please install an earth leakage breaker without fail. The installation of an earth leakage breaker is compulsory in order to prevent electric shocks or fire accidents. (Since this condensing unit employs inverter control, please use an impulse withstanding type one to prevent the earth leakage breaker from false activation.)

Note

- a) Use only copper wire.
- Do not use any supply cord other than the one specified in parenthesis for each type of cord mentioned below.
 - Braided cord (Cord designation 60245 IEC 51), if allowed in the relevant part 2.
 - Ordinary tough rubber sheathed cord (Cord designation 60245 IEC 53)
 - Flat twin tinsel cord (Cord designation 60227 IEC 41)
 - Ordinary polyvinyl chloride sheathed cord (Cord designation 60227 IEC 53)
- Please do not use any cord other than polychloroprene sheathed flexible cord (Cord designation 60245 IEC 57) for condensing unit use.
- b) A grounding wire must be connected before connecting the power cable. Provide a grounding wire longer than the power cable.
- c) Ground the unit. Do not connect the ground wire to a gas pipe, lighting rod or telephone grounding wire.
If improperly grounded, an electric shock or malfunction may result.
- d) The installation of an impulse withstanding type earth leakage breaker is necessary. A failure to install an earth leakage breaker can result in an accident such as an electric shock or fire. Do not turn on the power until the electrical work is completed. Be sure to turn off the power when servicing.
- e) Please do not use a phase advance capacitor for power factor improvement under any circumstances. (It does not improve power factor, while it can cause an anomalous overheat accident.)
- f) For power supply cables, use conduits.
- g) Please do not lay electronic control wires (remote controller and signal wires) and other high current cables together outside the unit. Laying them together can result in malfunction or failure of the unit due to electric noise.
- h) Power cables and signal wires must always be connected to the terminal blocks respectively and secured them with cable fastening clamps provided in the unit.
- i) Clamp cables so that they may not touch the pipe, etc.
- j) When cables are connected, please make sure to check no loose connection or disconnection at connecting coupling of all electrical components in the control box and then attach the cover to control box securely. (Improper cover attachment can result in malfunction or a failure of the unit, if water penetrates into the control box.)
- k) Make sure to use circuit breakers (earth leakage breaker and circuit breaker) of proper capacity.
Use of breakers of larger capacity could result in trouble on components or fire accident.
The circuit breaker should isolate all poles under over current.
- l) Install an isolator or a cut-off switch on the power supply line in accordance with the local codes and regulations. The isolator shall be locked to keep the power supply line in OFF state in conformity with EN60204-1.
- m) After maintenance service, be sure to restore all wiring, bundling wire and wiring route to their original state in order for them not to touch to the metal parts.
- n) When tightening electric wires and operation circuit wires to the terminal block, tighten the screws at torques as shown in the table at right.

Screw size	Tightening torque (Nm)
M4	1.0 ~ 1.3
M5	2.0 ~ 2.5
M6	4.0 ~ 5.0
M8	9.0 ~ 11.0
M10	18.0 ~ 23.0

Instructions

Electric characteristics for (50Hz)

Item	(Unit)	OP-UPAC030COP04E
Nominal output	(kW)	15.2 (7.6/unit × 2 units)
Power supply		380/400/415 V 3N~ 50Hz
Electric characteristics	Power consumption	(kW) 23.78/23.78/23.78
	Operation current	(A) 40.0/38.0/36.6
Min. wire size	(mm ²)	L1, L2, L3 :16mm ² [70m], N: 25mm ²
Operation circuit wire size	(mm ²)	2.0
Earth cable size	(mm ²)	(If conductor is Copper or Aluminum) 16
Earth leakage breaker	Rated current	(A) 50
	Rated sensitivity current	(mA) 50 (Operation time 0.1 sec. or less)

Note:

1. Electric characteristics are based on the condenser suction air temperature at 32°C, evaporation temperature -10°C and condensing unit inlet superheat degree 10 deg.
2. Figure in [] of the minimum wire size shows the maximum wire length (m) with the voltage drop at 2%.
3. This table's Earth cable size is based on "Min. wire size". If power cable size would be selected bigger than "Min. wire size", please select appropriate Earth cable size based on the power cable size.

External signal output

Part of operating states can be output from the controller of condensing unit.

7.1. Alarm signal :

If the condensing unit stops under abnormal condition, an alarm signal is released.

7.2. Compressor operation signal :

Signals of compressor operation and stop can be extracted.

- Extract signals via a relay.

Where the power for the relay contacts is taken from a terminal box, connect the wires as shown by the electric wiring in the next section.

List of external output

	Name	Purpose (Factory default)	Specifications	Point of caution	
External input	CNS1(Green)	no use	Non-voltage contact (DC12V)	Stops when open.	
	CNS2(Red)	ON-OFF SW		Valid when short-circuited.	
	CNS3(Brown)	Compulsory oil return control input		Valid when short-circuited.	Use connectors fixed with tapes on the outer wall of the control box.
	CNG1(Blue)	Gas cooler fan snow control input		Valid when short-circuited	
	CNG2(White)	Multistep demand input		Valid when short-circuited.	
External output	CNH(Blue)	Operation output	12 VDC output (10 mA)	-	
	CNY(White)	Error output		-	
	CNZ1, CNZ2 (Red) (Black)	Set with 7-segment (*)		(Molex: Provide 5557-2R, 5556T at site.)	

(*) 0: Operation output 1: Error output 2: Compressor ON output 3: Fan ON output 4: Oil return operation output 5: High pressure control output 6: Compressor operation time (Maintenance time) time-over output

For the default output, see page 30.

7.3. Signal cable connection procedures for connecting Module controller

- Signal cables use DC 5 V. Never connect wires for 400 V. It trips the protective fuse on the PCB.
 - Confirm that it is so arranged that 400 V power will not be applied to signal cables.
 - Check the resistance of signal cable terminal board before turning power on . If the resistance is 100Ω, or less, a power cable may be connected to the signal cable terminal board.
- Communication method is based on RS485.
- Connect signal cable to A, B on the terminal board.
- Signal cables has the polarity. Connect them as shown in fig. 25.

Instructions

- Communication board (PWB6) is inserted on the back side of Communication Terminal Block.
- PWB6's bracket is screwed. When PWB6 needs to be pulled out, unscrew from bracket.

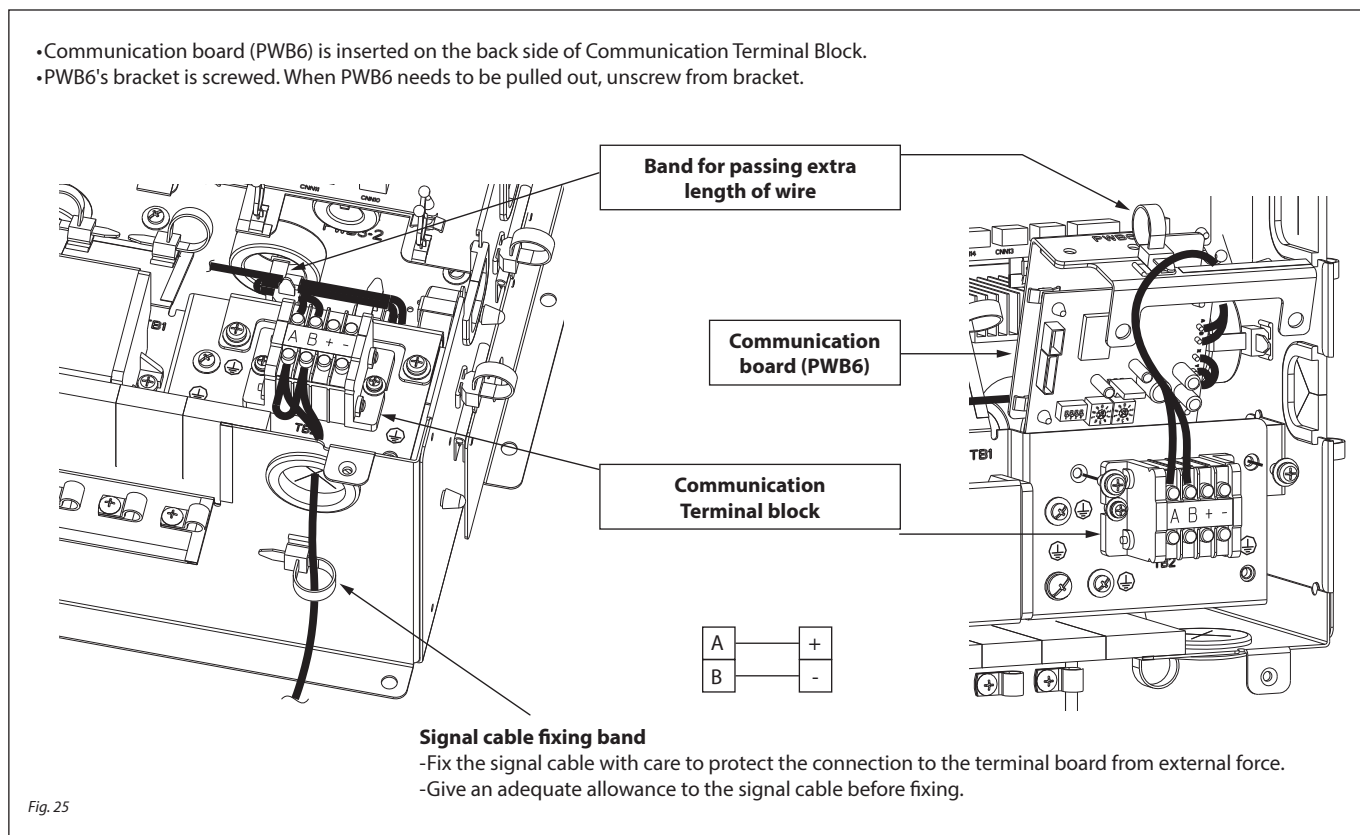

- Connect it to the terminal board using M3.5 crimp terminal as shown in the sketch below.

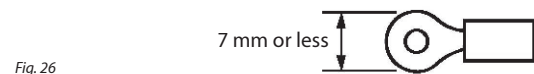

- Use an adequate screwdriver to tighten terminal screws. If it is tightened too much, it could destroy screws. For the tightening torque of screw, see the table below.

Tightening torque (N·m)		
M3.5	Power cable/signal cable terminal board	0.68 ~ 0.82

8 – Filling the system

- Never start the compressor under vacuum. Keep the compressor switched off.
- Use only the refrigerant for which the unit is designed for.
- Break vacuum with 7 - 10 bar of vapor CO₂.
- Then fill refrigerant in liquid phase through the medium pressure access port.
- The remaining charge is done until the installation has reached a level of stable nominal condition during operation.
- Never leave the filling cylinder connected to the circuit.

Instructions

9 – Setting the electronic controller

Following explanation refer to the overall control. Initial settings required at the test run are described on Page 37, 10.1 *Checking before turning on the power supply*".

9.1 Control items

This condensing unit has the following control functions.

Category	Control name	Description
Start	Control at start	Bypasses the start step at the starting.
Ordinary operation control	Calculation frequency control	Changes the operation frequency of condensing unit based on the low pressure (LP).
	Fan control	Controls the gas cooler fan speed aiming to achieve the high pressure being determined by ambient temperature.
	Medium pressure control	Controls the aperture of medium pressure receiver inlet electronic expansion valve to make constant the medium pressure being determined by ambient temperature and setting evaporation temperature.
	Inching prevention control	Operation immediately after a stop is inhibited to reduce the numbers of starts and stops.
Auxiliary control	Subcooling degree suppression control	Controls the aperture of subcooling electronic expansion valve, when it exceeds the upper and lower limit values of subcooling degree.
Protective control (*)	High pressure protective control	Reduces the operation frequency when the high pressure (HP) is too higher.
	Overcurrent protective control	Reduces the operation frequency when the current value is too higher.
	Discharge temperature overheat prevention	It controls the liquid bypass electronic solenoid valve and reduces the operation frequency further, when the discharge temperature (Td) is too higher.
	Oil return control	Controls such that condensing unit oil will return to the compressor.
Control valves	Electronic expansion valve for middle pressure receiver inlet	Controls the aperture of electronic expansion valve to make constant the medium pressure.
	Electronic expansion valve for liquid bypass	Lowers the discharge temperature by controlling the aperture of electronic solenoid valve, when the discharge temperature (Td) is too higher.
	Electronic expansion valve for subcooling coil	Controls the aperture of electronic expansion valve to maintain the subcooling coil superheat degree constantly.
At inverter error	Inverter error control	Control when the inverter PCB detects an error
Demand control	Frequency changing speed change/stop control	Lowers the maximum speed of operation frequency.

(*)Protective control initiates an extraordinary operation in order to protect the product when it is expected that it may run out the allowable ranges for the refrigeration cycle devices and electro/electronic parts. Once it reverts, as a result of control, to a state that it can operate within the allowable range, the control function is released and it returns to ordinary operation.

Instructions

9.2 Explanation of control

States of operation on the condensing unit can be observed on the segment and LED on the “condensing unit control PCB”. Method of the segment display, display items, and control contents are as explained below.

9.2.1. Display method

- Each item is displayed on the 7-segment display of 3-digit x 2 on the condensing unit PCB.
- To control the display, use SW7 to SW9 buttons (Refer page no 57).
SW9: Button to set the tens place of the code display.
SW8: Button to set the ones place of the code display.
SW7: Data delete/write button
- Select the code No. of each item by pressing SW9 for the tens place or SW8 for the ones place.
There are following 2 types for the identifying alphabet at the code display section.
“C”: “C00” to “C99”
“P”: “P00” to “P99”
- If SW9 (tens place) is pressed, it jumps to the leading code at each tens place. It passes over “C00” – “C99”, and displays “P00”.
- SW8 (ones place) displays in the order of 0 → 1 → 2 ... 9 → 0. It displays in the order of “P00” → “P01” → “P02” ... “P09” → “P00”.
- Adjust at the code to change, hold down SW7 (Data write/delete) for 3 seconds continuously.
- Data at the data display section flickers at every 0.5 second. (Unless SW is pressed for 10 seconds in this state, the write mode terminates.)
- Press SW9 (tens place) and SW8 (ones place) to change data.
- If SW7 is pressed for 3 seconds or more continuously in the state of flicker, the date display section changes to the data lighting. By this operation, data of each item is saved in EEPROM, and the operation is controlled with this content henceforth.
- Contents which have been changed and saved are used for control even if the power supply is turned off and backed on again.

9.2.2. Display priority

- Display priority is as shown by the following table.

Priority	Display content	
High ↑ ↓ Low	Receiving of line check command	[QO]
	ROM version display	[WLMC], or other
	Error display	[Exx]
	Operation code display	[oPE-X]
	Compressor oil check operation display	[oil]
	Ordinary channel display	[Cxx][Pxx][xx]

- If the state of the display at 1 is released, it changes to the auto display.
- If SW8 or SW9 is pressed in the display at 1, it changes to display [C00].
- However, if the switch is not pressed for 10 seconds, it displays by the priority of 1).
- Display change : Special display shows other than CXX, PXX and FXX.

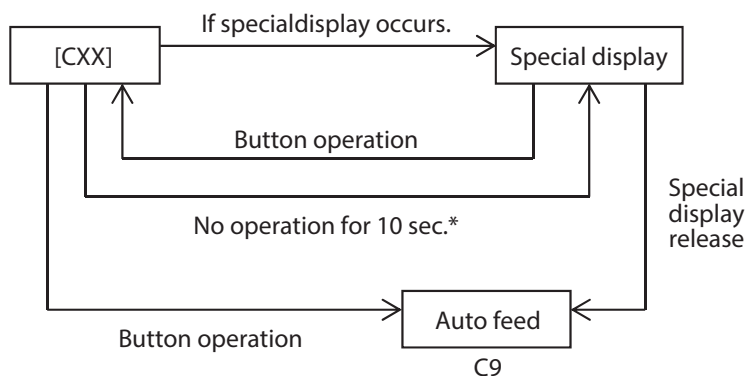

Fig. 27

* If the special display is released in this period, [CXX] or [PXX] continues.

Instructions

9.3. Display item

Display of data and operation status

Order of display is "C00" → "C01" ... "C93" → "C00".

•Data

Table 1: Operation information

Code No.	Display contents	Display range	Min. unit	Setting for combination	Remarks
Error display	[Exx]				
Caution display	[oPx][oPE-X]				
Special display	[QO][WLMC](ROM version display) [oil]				
Code No.	Data display contents	Data display range	Min. unit		Remarks
<Sensor value, actuator information>					
C00	CM1 operation frequency	0~255	1Hz		
C01	CM2 operation frequency	0~255	1Hz		
C02	Tho-A outdoor air temp.	L,-25~85	1°C		
C03	Tho-G1 gas cooler inlet temp. 1	L,-30~150	1°C		
C04	Tho-G2 gas cooler outlet temp. 2	L,-40~100	1°C		
C05	Tho-M medium pressure receiver inlet temp.	L,-40~100	1°C		
C06	Tho-INJ1 gas injection temp.1	L,-40~100	1°C		
C07	Tho-INJ2 gas injection temp.2	L,-40~100	1°C		
C08	Tho-D1 discharge pipe temp. (CM1)	L,-30~150	1°C		
C09	Tho-D2 discharge pipe temp. (CM2)	L,-30~150	1°C		
C10	Tho-C under-dome temp. (CM1)	L,-30~150	1°C		
C11	Tho-C under-dome temp. (CM2)	L,-30~150	1°C		
C12	Tho-P1 power transistor temp. (CM1)	L,-20~120	1°C		
C13	Tho-P2 power transistor temp. (CM2)	L,-20~120	1°C		
C14	Tho-SC subcooling coil temp.	L,-40~100	1°C		
C15	Tho-R liquid feed pipe temp.	L,-40~100	1°C		
C16	Tho-S1 suction pipe temp.	L,-40~100	1°C		
C17	Tho-S2 suction pipe temp.	L,-40~100	1°C		
C18	CT1 (CM1) current	0~50	1A		
C19	CT2 (CM2) current	0~50	1A		
C20	EEVG medium pressure receiver inlet electronic expansion valve	0~470	1 pulse		
C21	EEV-LB1 liquid bypass electronic expansion valve	0~470	1 pulse		
C22	EEV-LB2 liquid bypass electronic expansion valve	0~470	1 pulse		
C23	EEVSC subcooling coil expansion valve	0~470	1 pulse		
C24	FM01 actual speed	0~999 (*1)	1 (10 min ⁻¹)		
C25	FM02 actual speed	0~999 (*1)	1 (10 min ⁻¹)		
C26	PSH high pressure sensor	0~15	0.01 MPa (0.1 MPa when 10 MPa or more)		Showing pressure value in 7 segment is in MPa. If necessary to refer the value in bar unit, to multiple with 10 from MPa into bar
C27	PSL low pressure sensor	0~8.5	0.01 MPa		
C28	PSM medium pressure sensor	0~8.5	0.01 MPa		
C29	Inverter 2ry current 1	0~50	1A		
C30	Inverter 2ry current 2	0~50	1A		
C31	Pressure switch	0, 1 (0: Open 1: Short)			100's place: 63H1, 2
					10's place: Spare
					1's place: Spare

Instructions

Code No.	Data display contents	Data display range	Min. unit		Remarks
C32	Level switch	0, 1			100's place: OLS1-2 (*3)
					10's place: OLS2-2 (*3)
					1's place: CLS(*4)
C33	External input	0, 1 (0: Open 1: Short) (*2)			100's place: CNS1
					10's place: CNS2
					1's place: CNS3
C34	Relay output	0, 1 (0: Open 1: Short)			100's place: Spare
					10's place: Spare
					1's place: EV-OIL3
C36	Relay output	0, 1 (0: Open 1: Short)			100's place: Crankcase heater 1
					10's place: Crankcase heater 2
					1's place: Spare
C37	Relay output	0, 1 (0: Open 1: Short)			100's place: Cooling fan
					10's place: Ventilation fan
					1's place: Spare
C38	Relay output	0, 1 (0: Open 1: Short)			100's place: SVHG1
					10's place: SVHG2
					1's place: SV-INJ1
C39	Relay output	0, 1 (0: Open 1: Short)			100's place: SV-INJ2
					10's place: SV-OIL1-1 SV-G
					1's place: SV-OIL1-2
C40	Relay output/external output	0, 1 (0: Open 1: Short)			100's place: SV-OIL2-1
					10's place: SV-OIL2-2
					1's place: External output (CNZ1)
C41	External output	0, 1 (0: Open 1: Short)			100's place: External output (CNZ2)
					10's place: Operation output (CNH)
					1's place: Error output (CNY)

(*1) 7 segment display of C24, C25 indicates 10 min⁻¹/count.

(*2) When the pulse input is set, 0 and 1 are switched if it changes Open→Short.

(*3) 0: OLS OFF (No oil), 1: OLS ON (With oil)

(*4) 0: CLS OFF (With liquid), 1: CLS ON (No liquid)

<Unit information>					
C44	Compressor total operation time (CM1)	0~655 (*1)	1(100h)		
C45	Compressor total operation time (CM2)	0~655 (*1)	1(100h)		
C46	Medium pressure saturation temp.	-50~30	0.1°C		In the unit of 1°C in the range beyond display (-10°C or under)
C47	Suction pressure saturation temp.	-50~30	0.1°C		In the unit of 1°C in the range beyond display (-10°C or under)
C48	Subcooling coil temp. sensor 1 saturation pressure	0~8.5	0.1 bar		
C49	Suction superheat degree 1	0~50	0.1deg		
C50	Suction superheat degree 2	0~50	0.1deg		
C51	Subcooling coil superheat degree	0~50	0.1deg		
C52	Under-dome superheat degree 1	0~50	0.1deg		
C53	Under-dome superheat degree 2	0~50	0.1deg		
C61	Demand rate display	0~100	1%		

(*1) 7 segment display of C44, C45, C54, C55 indicates 100 h as 1 count.

(*2) 7 segment display of C59, C60 indicates 10 / min as 1 count.

<Error counter information>					
C95	Auto feed display 1				Feeds and displays C26, C28, C27.
<Others>					
C97	Program/sub version	000~991			
C98	Program/POL version	0.00~9.99	0.01		

Instructions

Setting parameter display

•If following controls take place during operation, data corresponding to each control is displayed on 7-segment display

Table 2: 7 segment software input

Code No.	Data display contents	Data display range	Min. unit		Remarks
<User setting>					Setting of contents of functions described on catalogue
P02	Gas cooler fan snow control → (15-8)	0: (Default) 0, 1			0: External snow fan control invalid (Default) 1 or more: External snow fan control valid
P03	Gas cooler fan snow control ON time setting → (15-8)	30: (Default) 10, 30~, 60 0 [sec]	30		Changes 10, 30, 60, 90 ... 600.
P04	Demand rate change value (1st stage at multistage setting)	80: (Normally) 0, 40, 60, 80			
P05	External output (CNZ1) function assignment	2: (Default) 0 - 20	1		
P06	External output (CNZ2) function assignment	4: (Default) 0 - 20	1		
P07	External input (CNS2) function assignment				0: External operation input 1: Demand input 2: Quiet mode input 3: Error reset
P08	External input (CNS3) function assignment	4: (Default) 0 - 20	1		4: Compulsory oil return control input 5: Gas cooler fan snow control input
P09	External input (CNG1) function assignment	5: (Default) 0 - 20	1		9: Multistage demand input
P10	External input (CNG2) function assignment	9: (Default) 0 - 20	1		
P11	Quiet mode setting	0: (Default) 0 - 9	1		
P14	Multistage demand rate change value (2nd stage)	60: (Normally) 0, 40, 60, 80			
P15	Multistage demand rate change value (3rd stage)	40: (Normally) 0, 40, 60, 80			
P17	Back up compressor operation setting	1: (Default) 0, 1			0: Limited to 80 hours of Back up compressor single operation 1: No limit to the hours for Back up compressor single operation
P19	Compressor oil check operation Compressor speed	70 X 2 Comps. (Default) 30 - 100			
P20	Error inspection reset	0,1	-	0	0: Normal, 1: Reset If it is selected 1 and reset Error code indication, kindly return [P20] into 0.
<Service personal setting>					General setting adjusted by service personal at site
P48	Prohibition to start by compressor dilution ratio protection	0: (Default) 0, 1			0: Valid 1: Invalid
P55	Compressor stop after starting oil return control	0: (Default) 0, 1			0: Valid 1: Invalid
P56	Change oil equalization control setting	0: (Default) 0, 1			0: Executing oil reutrn operation and oil equalization control 2' 1: Executing oil equalization control 2, oil reutrn operation and oil equalization control 2'
P57	Total time of oil return control with 2 compressors running	50: (Default) 5 - 180	1 min.		
P58	Oil return time change value	15: (Default) 5 - 15	1 min.		
P60	Oil return frequency change value	70: (Default) 40 - 104 (rps)	1		
P61	EEVSC target superheat degree change value	20: (Default) 1 - 40 (0.5 - 20 deg)	1		
P62	EEV-LB target discharge pipe temp. change	0: (Default) -20 - 20 deg	1		
P63	EEVSC target subcool degree change	8: (Default) 4 - 40 (2 - 20 deg)	1		
P64	Simultaneous oil return time ℓ1 by expansion valve control	15: (Default) [min]	1 min		Values change 1→2→3 ...→20.
P65	Distributed oi return time by expansion valve control ℓ2	3: (Default) [min]	1 min		Changes 1 → 5 at 1 min intervals.

Instructions

Code No.	Data display contents	Data display range	Min. unit	Remarks
P66	Threshold value X for the condition in which two compressors start simultaneously	20(10Deg.K): (Default) 20~40 (10~20Deg.K)	1	0.5 Deg.K per 1 count
P83	Current safe correction value	0: (Default) -3~+6	0.5A	
P84	Oil return control type	10: (Default)		0: Refrigerant gas flow velocity oil return 1: Expansion valve oil return (Simultaneous) 2: Expansion valve oil return (Distributed) 10: Auto select (If 10 is selected and controller connected, 1 : Expansion valve oil return control (Simultaneous) is activated automatically))

Error code display and LED indication

Error code	Unit LED		2-screen 7 segment display	Inspection contents
	Green	Red		
E32	Keep Flashing	Once	E32	Power supply open phase Power supply reverse phase (Export 3P, 4-wire type only)
E36	Keep Flashing	Once	E36-1	Td error (Tho-D1)
		Twice	E36-2	Discharge pipe temp. error (Tho-D2)
E37	Keep Flashing	Once	E37-1	Gas cooler sensor 1 broken wire (Tho-G1)
		Twice	E37-2	Gas cooler sensor 2 broken wire (Tho-G2)
		3-time	E37-3	Medium pressure receiver inlet temp. sensor broken wire (Tho-M)
		4-time	E37-4	Gas injection inlet temp. sensor broken wire (Tho-INJ1)
		5-time	E37-5	Gas injection inlet temp. sensor broken wire (Tho-INJ2)
		6-time	E37-6	Subcooling coil sensor broken wire (Tho-SC)
		7-time	E37-7	Liquid feed pipe temp. sensor broken wire (Tho-R)
E38	Keep Flashing	Once	E38	Outdoor temp. sensor broken wire (Tho-A)
E39	Keep Flashing	Once	E39-1	Discharge pipe temp. sensor 1 error (Tho-D1)
		Twice	E39-2	Discharge pipe temp. sensor 2 error (Tho-D2)
E40	Keep Flashing	Once	E40	High pressure switch ON (63H1-1, 2)
E41	Keep Flashing	Once	E41-1	Power transistor overheat (CM1) (5-time/1 h)
		Twice	E41-2	Power transistor overheat (CM2) (5-time/1 h)
E42	Keep Flashing	Once	E42-1	Current cut (CM1)
		Twice	E42-2	Current cut (CM2)
E43	Keep Flashing	Once	E43-1	Liquid back error (CM1)
		Twice	E43-2	Liquid back error (CM2)
E45	Keep Flashing	Once	E45-1	Inverter-PCB transmission error (CM1)
		Twice	E45-2	Inverter-PCB transmission error (CM2)
E48	Keep Flashing	Once	E48-1	DC fan motor No.1 error (FMO1)
		Twice	E48-2	DC fan motor No.2 error (FMO2)
E49	Keep Flashing	Once	E49	Low pressure error (PSL ON)
E51	Keep Flashing	Once	E51-1	Power transistor overheat (CM1) (15 min continuously)
		Twice	E51-2	Power transistor overheat (CM2) (15 min continuously)
E53	Keep Flashing	Once	E53	Suction pipe temp. sensor broken wire (Tho-S)
E54	Keep Flashing	Once	E54-1	Low pressure sensor broken wire (PSL) Low pressure sensor output error
		Twice	E54-2	High pressure sensor broken wire (PSH) High pressure sensor output error
E55	Keep Flashing	Once	E55-1	Under-dome temp. sensor 1 broken wire (Tho-C1)
		Twice	E55-2	Under-dome temp. sensor 2 broken wire (Tho-C2)
E56	Keep Flashing	Once	E56-1	Power transistor temp. sensor 1 broken wire (Tho-P1)
		Twice	E56-2	Power transistor temp. sensor 2 broken wire (Tho-P2)
E58	Keep Flashing	Once	E58-1	Compressor step-out error (CM1)
		Twice	E58-2	Compressor step-out error (CM2)
E59	Keep Flashing	Once	E59-1	Compressor start error (CM1)
		Twice	E59-2	Compressor start error (CM2)

Instructions

Error code	Unit LED		2-screen 7 segment display	Inspection contents
	Green	Red		
E60	Keep Flashing	Once	E60-1	Medium pressure sensor broken wire (PSM-1) Medium pressure sensor output error
		Twice	E60-2	Medium pressure sensor broken wire (PSM1-2) Medium pressure sensor output error
		3 times	E60-3	Medium pressure sensor broken wire (PSM2-2) Medium pressure sensor output error
E63	Keep Flashing	Once	E63	External input error stop
E88	Keep Flashing	Once	E88-1	Oil level error (CM1)
		Twice	E88-2	Oil level error (CM2)
E89	Keep Flashing	Once	E89	CPU-CPU communication error

9.4. Control at start

Following control takes place when starting the condensing unit.

- Turn ON the operation switch of Module controller.
- As the low pressure (LP) picks up to the start condition (LP > Evaporation temperature setting value), the condensing unit starts 60 seconds later.
- Opens the liquid injection solenoid valve synchronized with the start of compressor, and starts the discharge gas overheat degree control.

At the compressor start,

- If saturation temperature of suction pressure is higher than the set evaporation temperature plus [P66] 's set value (default 10 deg.K), two compressors raise frequency to 45 Hz simultaneously once.
- If saturation temperature of suction pressure is not higher than the set evaporation temperature plus [P66] 's set value (default 10 deg.K), one compressors raise frequency to 40 Hz once.

After operating for 105 seconds, it changes to the calculation frequency control.

9.5. Calculation frequency control

•Suction gas pressure control

As it is described also at the section "1. Introduction", the cooling capacity by load is controlled with the low pressure (LP). The low pressure (LP) varies depending on the compressor speed which changes depending on the operation frequency. In order to maintain a necessary cooling capacity, the low pressure (LP) value that corresponds to the cooling capacity is set so as to control the inverter output frequency such that the low pressure (LP) being detected by the low pressure sensor will become the set low pressure.

•Operation stop by decreased low pressure (LP)

1) Running compressor number reduction control

1-1) From 2 compressors to 1 compressor

When following all conditions are established, running compressor number will be reduction from 2 to 1.

- Both LP pressure < Low pressure control setting pressure (LPSP) continuously for 3 minutes and Compressor frequency keeps 40rps continuously for 2 minutes.
- LP pressure < internal preset pressure value (it is preset value outside of LP operation range)

1-2) From 2 compressors to 0 compressor or from 1 compressor to 0 compressor

When LP pressure < Low pressure setting OFF value (according to the table on page 39) continuously for 2 minutes, compressor will be stopped.

2) Low pressure protective control

When LP < preset protective control starting pressure (it is preset value outside of LP operation range), following 2 controls are activated.

- Hot gas bypass solenoid valve would be Opened
- Compressor rotation speed would be decreased.

If LP pressure returned into operation range, then this control will be deactivated.

3) Low pressure error (Protective Stop)

When LP < Error pressure 0.58MPaG for 2 seconds, all compressor would be stop.

After 3 minutes from stopping by Low pressure error, when LP > Low pressure setting ON value (see page 39), compressor can be restarted.

•Setting of pressure setting value

Pressure setting value is set to the central value between the lower value of pressure setting (PsD) and the upper value of pressure setting (PsU). When Module controller code "r28" is set to 1, PsD is the value set in module controller code r01 and PsU is the value set in module controller code r02. When Module controller code "r28" is set to 0, PsD is the value +1.0bar from value set with rotary SW of the condensing unit and PsU is the value -1.0bar from value set with rotary SW of the condensing unit.

Instructions

•Flow chart of respective operations

Flow chart of operations is as shown below.

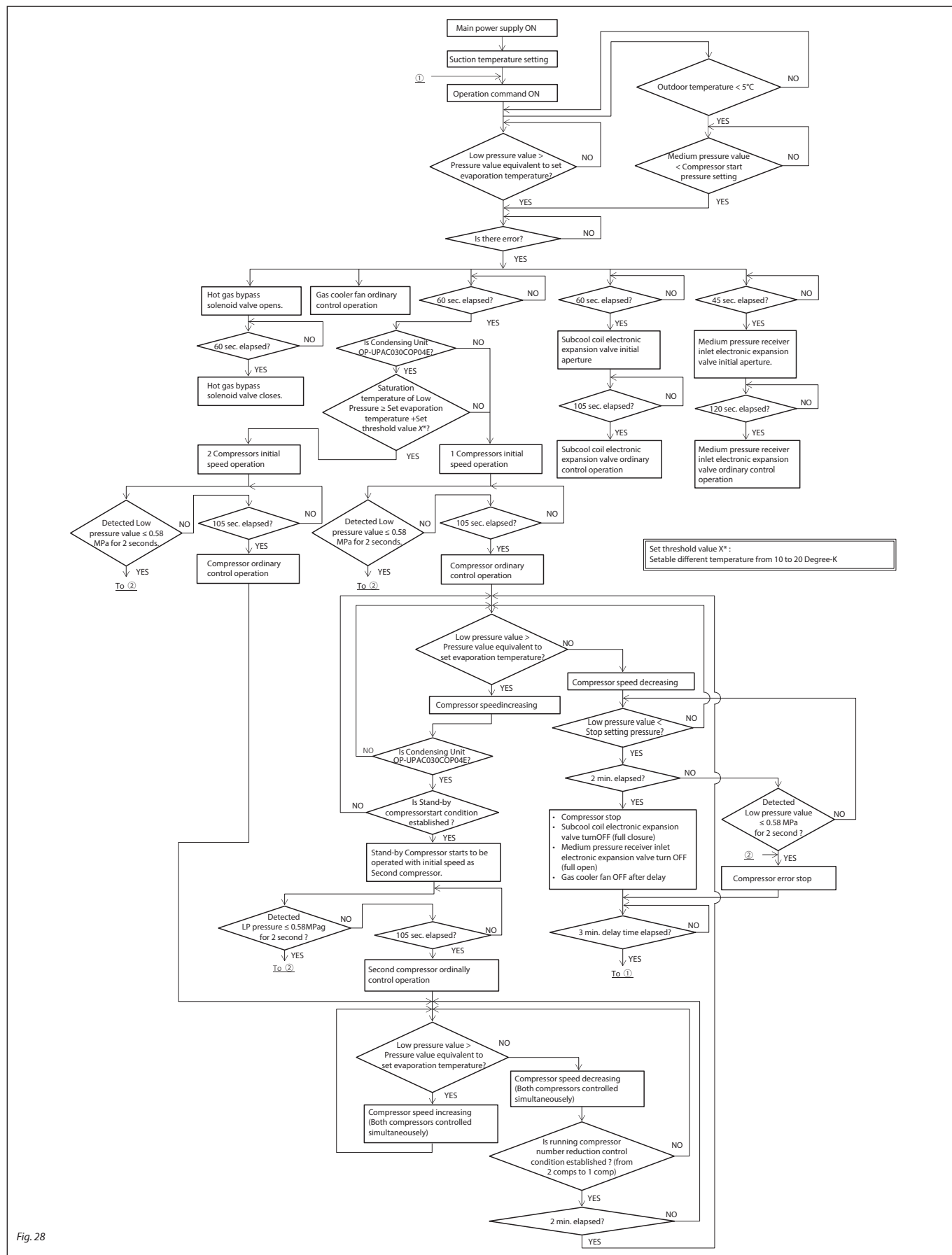

Fig. 28

Instructions

9.6. High pressure overshoot prevention (Overload control)

This control suppresses the high pressure (HP) from rising excessively. If the detected high pressure (HP) exceeds a preset value, the frequency output is controlled.

Restriction on the frequency output

Forcible frequency decrease ... Start value: 116 bar, release value: 113 bar

Stop by pressure overshoot

High pressure breaker Setting value: 140 bar
(Displays the alarm code "E40")

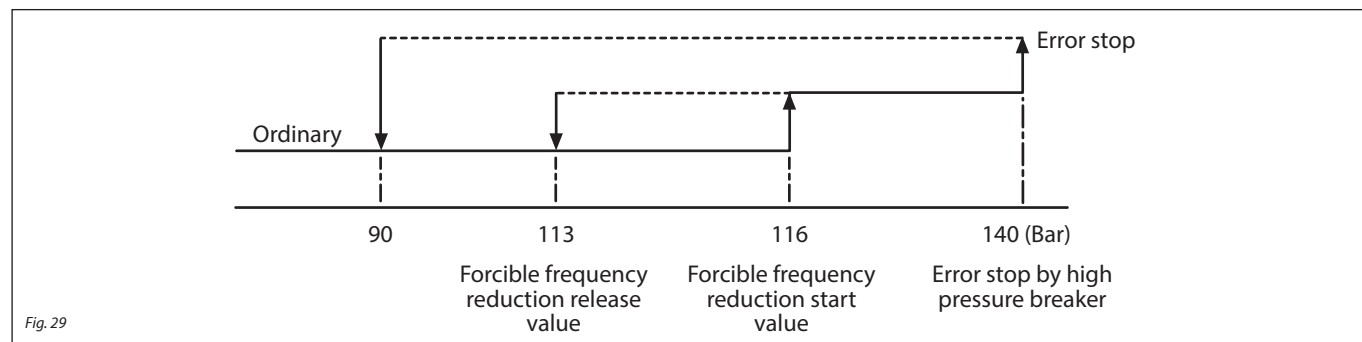

Lower limit of forcible frequency reduction: 40 rps

9.7. Over-current prevention (Overload control)

This control suppresses the compressor operating current from rising excessively. If the detected secondary current of inverter becomes higher than the value preset as shown below, the frequency output is restricted by the control PCB of condensing unit.

Restriction of frequency output

Forcible frequency reduction ... Start value: 23 A, release value: 22 A

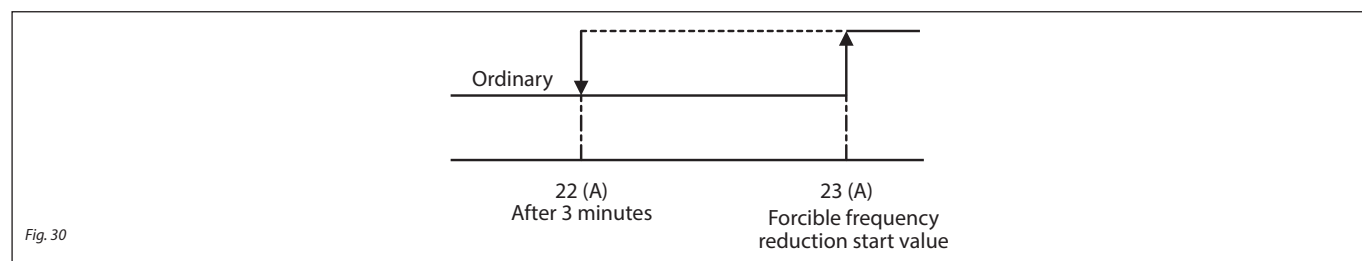

9.8. Discharge temperature overheating prevention (Overload control)

•When the temperature of gas discharged (T_d) from each compressor becomes too higher, the aperture of liquid bypass electronic expansion valve is controlled in order to cool the state of high-stage suction gas and lower the high-stage discharge gas temperature by bypassing 2-phase flow (liquid/gas) at the gas cooler outlet to the compressor medium pressure injection. If the discharge temperature exceeds 132°C, the compressor frequency decreases.

•When the discharge gas temperature (T_d) rises to 140°C even if this control is turned on, the condensing unit is stopped with the retry stop. If the retry stop repeats 5 times, however, the machine is stopped with the error stop. (Alarm code "E36" is displayed.)

Instructions

9.9. Middle pressure overshoot prevention

9.9.1. Compressor

This control suppresses the middle pressure (MP) from rising excessively during compressor running.

If the detected middle pressure (MP) exceeds 80bar (in case that LP set pressure < LP sensing pressure) or 76bar (in case that LP set pressure ≥ LP sensing pressure), stop the compressor. Control is end when 180 seconds pass after compressor stop and middle pressure (MP) below 74bar.

Compressor

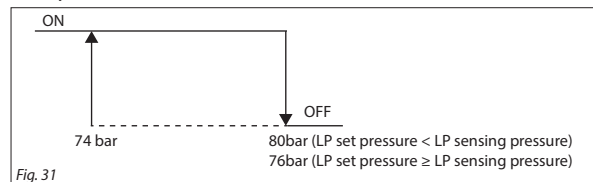

9.9.2. Standstill

This control suppresses the middle pressure (MP) from rising excessively at standstill.

If the detected middle pressure (MP) exceeds 75bar, EEVSC is opened and EEVG is closed. Control is end when middle pressure (MP) below 73bar or 180 seconds pass after control start.

EEVSC

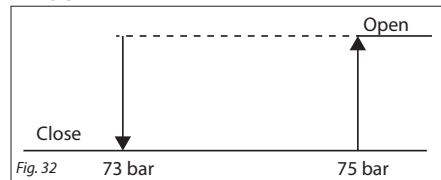

EEVG

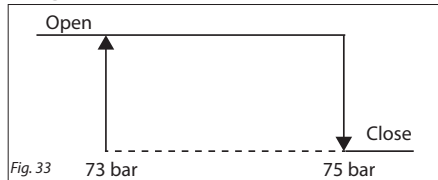

9.10. Oil return operation control

In the event that total operation time at lower than the frequency in the following table (excluding the stop time) exceeds 2 hours at first power on or 3 hours from second or more times of oil return and total oil loss exceeds the specified value the following control is performed.

No.	Pattern for the number of running compressor	Compressor specified speed
1	1 compressor	< 90 rps x 1 compressor
2	2 compressors (*Note)	< 70 rps x 2 compressors

It operates with the compressor frequency fixed at the frequency as shown in the table above.

***Note:** In case that oil return operation control is started due to oil level switch (OLS1-1 or OLS2-2) detecting "no oil" during both 2 compressors running, Oil equalization control is started after completing Oil return operation control.

Oil equalization control is to equalize oil level between 2 oil pods by generating the gap of compressor frequency and feeding the oil from lower frequency compressor side to higher frequency compressor side.

9.11. Oil level error

This control outputs information about insufficient amount of oil in the compressor of condensing unit.

Set this control with SW6 -7.

- When SW6 -7 is OFF, oil level error [Enabled] * Factory setting
- When SW6 -7 is ON, oil level error [invalid].

Set output method with SW6 -5.

- When SW6 -5 is OFF, the opcode [oPE 88] is displayed on the 7 segments. * Factory setting
- When SW6 -5 is ON, all compressors are abnormally stopped. (Error Code: [E 88])
- When SW6 -7 is OFF, the following control is performed.

1. When the compressor is running and the oil level switch (*1) detects "no oil" for measurement seconds (*2) continuously, Oil return operation control (see above (10)) is operated.
2. After Oil return operation completes, condensing unit check oil level switch detection condition again.
3. If oil level switch detects "no oil" continuously for the measurement seconds (*3) again,
 - (i) When SW6-5 is OFF, the opcode [oPE 88] will be displayed on the 7 segments.
 - (ii) When SW6-5 is ON, all compressors are abnormally stopped.

After restart, if the compressor is running and the oil level switch detects "oil present" continuously for the measurement seconds(*3), reset it.

*1: Applicable Measuring oil level switch		*2: Measurement seconds setting	*3: Re-Measurement seconds after oil return operation control completion
Symbol	"No oil" Establishment condition		
OLS1-2, OLS2-2	Either OLS1-2 or OLS2-2 detects oil level low	100 sec.	100 sec. (Started from 10 min. later of oil return operation control completion)

Instructions

9.12. Time chart

During ordinary operation

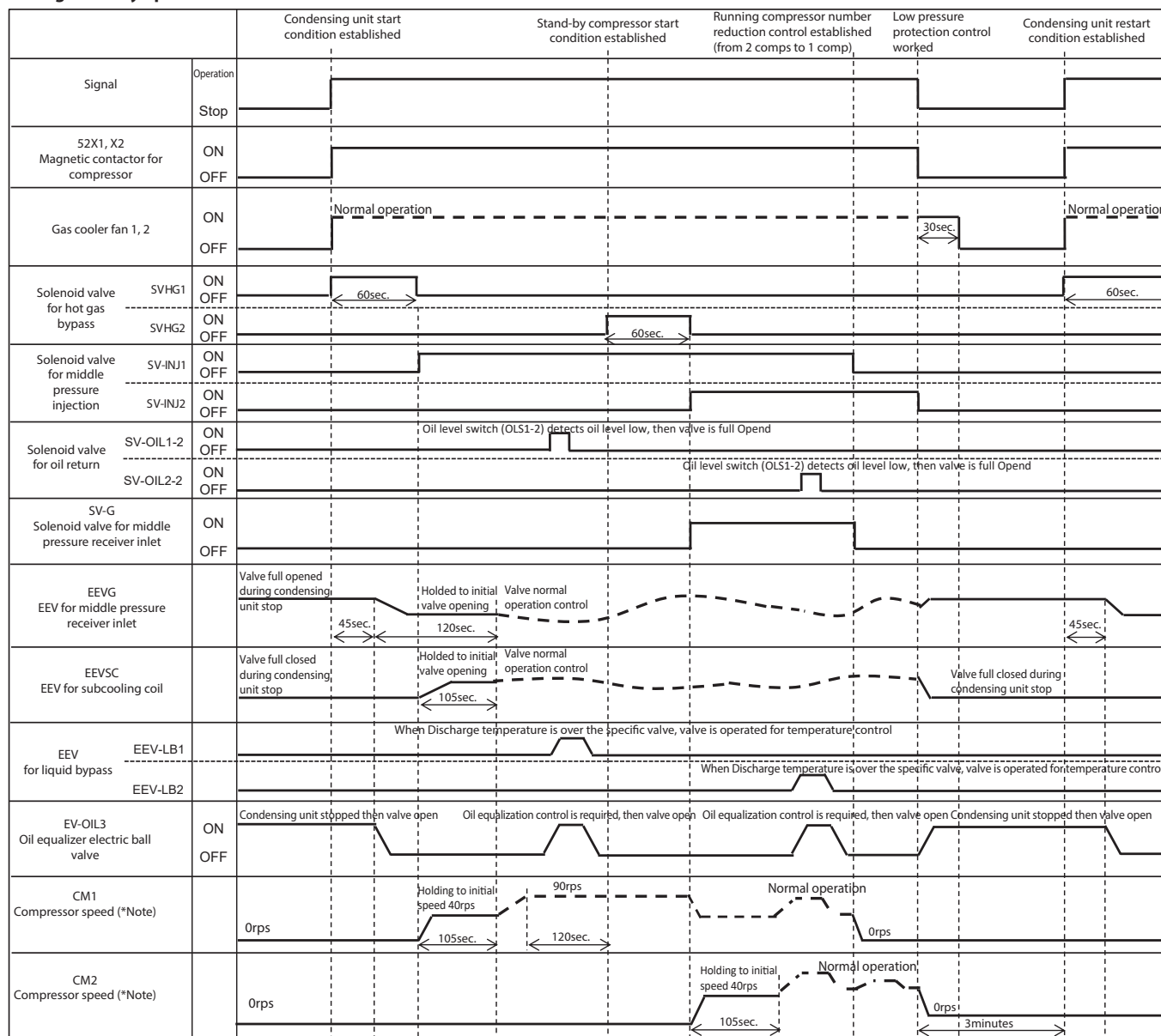

Fig. 34

***Note:** Showing trend is the case that saturation temperature of suction pressure is not higher than the set evaporation temperature plus [P66]'s set value. If saturation temperature of suction pressure is higher than the set evaporation temperature plus [P66]'s set value, CM1 and CM2 raise frequency to 45 Hz simultaneously.

See 9.4. Control at start.

Instructions

10 – Procedure and caution for commissioning

	Electric work should be implemented by a contractor approved by the power company.
	Install the earth leakage breaker. It is required to install the breaker to prevent electric shock or fire. (Since the inverter is used on this unit, select a shock wave resistant type.)

10.1. Checking before turning on the power supply

1. Reconfirm that wires are connected correctly.
2. Check the power terminal board and installation face with a 500 V megger to see if it is 1 M Ω , or more.
3. Charge specified condensing unit oil and specified quantity of refrigerant after evacuation. (Refer to 6.1. Charge of condensing unit oil, 6.2. Calculation of the charge quantity of condensing unit oil, 6.3. Replenishment of condensing unit oil after operation, 6.4. Refrigerant charge)
4. Confirm that the operation switch (CNS2) at the bottom of controller is turned OFF.
5. Check no cushioning material and no temporary bracket in refrigerating unit. They should have been removed before operation.
Check that pipe insulation have been added on the bare pipe section (where Cushioning cardboard between compressor and pipe had been existed) and it has been fixed with tape for each compressor.
6. Turn on the source power supply 6 hours or more before starting the compressor to energize the crankcase without turning on the operation switch (CNS2).

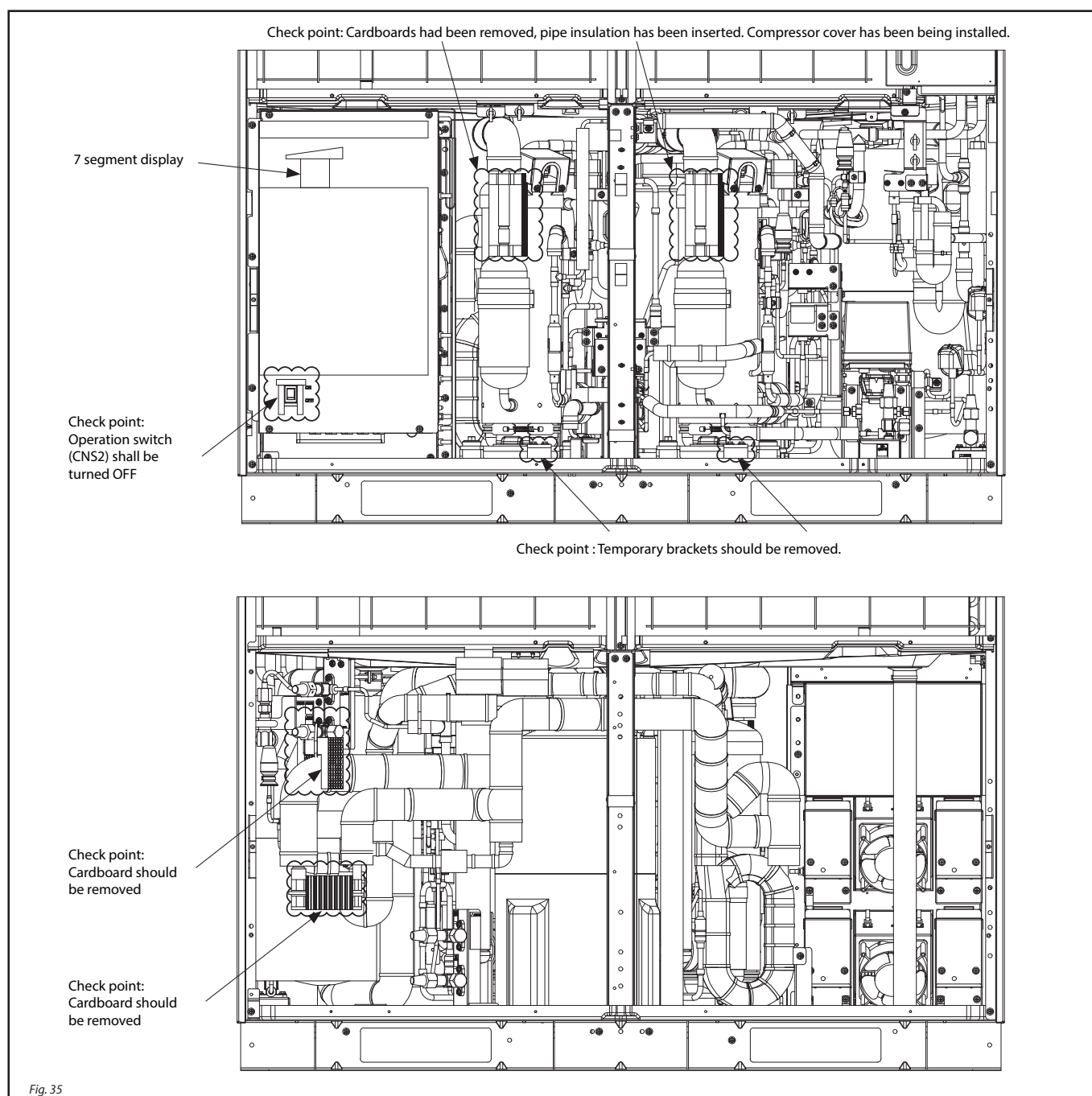

Instructions

10.2. Prevention of reverse phase operation

Compressor of this equipment runs in one direction only. If it is run in reverse direction, the compressor may fail to operate properly. To prevent the reverse phase operation, the unit is equipped with the reverse phase prevention relay which checks whether the phase of power supply is positive or reverse and, if it is in the reverse phase, displays the error code "E32", inhibiting the compressor start. In such occasion, check that the primary (power supply side) phase and secondary phase are the same phase.

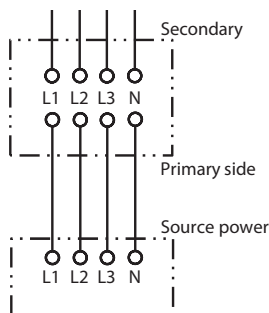

Fig. 36

Note:

Turn power off before replacing the connection for prevention of electric shock.

10.3. Prevention of short cycle operation

Short cycle operations (frequent repetitions of start and stop) could cause a short supply of lubrication oil as a result of excessive oil level rise at the time of starting. In addition, if a large start current flows repeatedly through the built-in motor, the motor may overheat, resulting in motor coil burnout.

To prevent the short cycle operation, it is necessary at the minimum to set such that the pattern as shown at right will be achieved. Major causes of short cycle operation are as follows

- Unbalanced load and condensing unit capacity
- Clogged suction strainer
- Improper setting of the operating pressure value

In addition to the above, where a unit cooler is used, the temperature sensor of inside compartment temperature regulator may be misplaced (the temperature sensor is blown directly by cold air from the unit cooler). Adjust the inlet suction superheating degree of condensing unit at 5 – 40 deg.

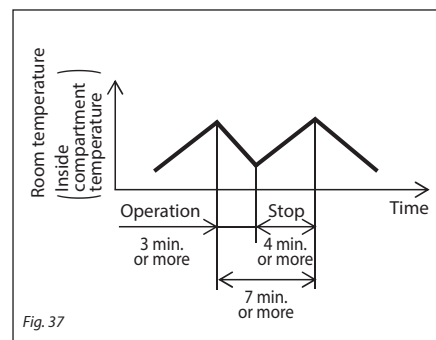

Fig. 37

10.4. Setting the high pressure cut-off

High pressure cut value (CUT OUT)	140 bar +0 bar -10 bar
-----------------------------------	---------------------------

10.5. Setting of operation control pressure (Setting evaporation temperature)

Setting value of the operation control pressure needs to be adjusted according to purposes. Special care is required particularly on the relation to the setting value of room temperature (inside compartment temperature) thermostat.

Room temperature (inside compartment temperature) is controlled by opening or closing the liquid solenoid valve with the room temperature (inside compartment temperature) thermostat. The condensing unit controls its capacity by detecting changes in the suction gas pressure (Ps) by opening or closing the liquid solenoid valve with the control PCB of condensing unit.

Evaporation temperature* can be set in the unit of °C over a range of 5 to -45°C with the rotary switches (SW1, 2) on the control PCB of condensing unit. The setting may be changed even during operation of condensing unit. The low pressure setting at the shipment is "SW1"="0", "SW2"="0"

A guide for setting of pressure value is shown below.

*1 The evaporation temperature means the saturated temperature of suction pressure.

Instructions

<Example setting value>

Purpose	Inside compartment temp. range	Inside compartment std.setting (Thermo ON value)	Evaporation temp. (Setting value)	Pressure equivalent to evaporation temp.	Low pressure setting OFF value	Low pressure setting ON value	Error pressure
Fruit, vegetables	2~15°C	5~10°C	-10°C	25.5 bar	13.3 bar	30.5 bar	5.8 bar
Meat, fishes	-2~2°C	0°C	-17°C	20.6 bar	13.3 bar	25.6 bar	5.8 bar
Frozen foods	-20°C~-18°C	-18°C	-40°C	9.0 bar	6.0 bar	11.0 bar	5.8 bar

The low pressure setting (OFF value, ON value) and error pressure in the table above become as shown below depending on the evaporation temperature (set by rotally switch).

Evaporation temperature (setting value)	Converted pressure (setting value)	Low pressure setting OFF value	Low pressure setting ON value	Error pressure
+5 ~ -19	38.7 bar ~ 19.3 bar	13.3 bar	Evaporation temperature Converted pressure (setting value) +5.0 bar	5.8 bar
-20 ~ -29	18.7 bar ~ 13.8 bar	9.0 bar	Evaporation temperature Converted pressure (setting value) +3.0 bar	
-30 ~ -45	13.3 bar ~ 7.3 bar	6.0 bar	Evaporation temperature Converted pressure (setting value) +2.0 bar	

Following table shows examples of setting for reference.

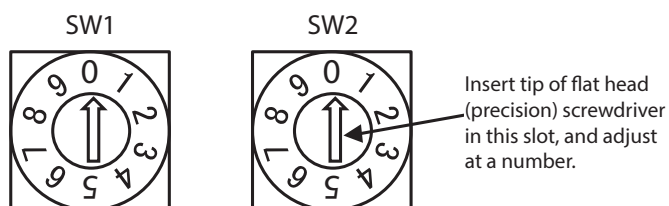

Fig. 38

<Examples of other setting>

Evaporation temp. to set	SW1 (Tens place)	SW2 (Ones place)
5°C	7	5
-5°C	0	5
-10°C	1	0
-40°C	4	0

When the evaporation temperature (setting value) is 5 - 19 °C, the low pressure cut value can be adjusted with the dip switches SW4-7, 4-8. (Although 13.3 bar is equivalent to evaporation pressure at -30°C, the compressor can be stopped without lowering to -30 °C by setting as shown in the table below.) SW4-7 and SW4-8 at the shipment is "SW4-7" = "OFF", "SW4-8" = "ON".

Shows the low pressure setting OFF value converted from evaporation temperature.

Low pressure control setting pressure (LPSP)		Low pressure setting OFF value
LPSP ≥ 18.7 bar		X bar
18.7 bar > LPSP ≥ 13.3 bar		9.0 bar
13.3 bar > LPSP		6.0 bar

SW 4-7	SW 4-8	Low pressure setting OFF value "X"
OFF	OFF	13.3 bar
ON	OFF	Pressure equivalent to "Evaporation temperature (setting value) -5 °C"
OFF	ON	Pressure equivalent to "Evaporation temperature (setting value) -10 °C"
ON	ON	Pressure equivalent to "Evaporation temperature (setting value) -15 °C"

Dip switch



Fig. 39

Instructions

10.6. Operation start

1. Turn on the operation switch (CNS2) at the bottom of controller.
2. Turn ON the power supply of condensing unit.
3. Turn ON the operation switch of the module controller.
4. When Low pressure value \geq Reset pressure or Outdoor air temperature $< 5^{\circ}\text{C}$ and Medium pressure value \leq Reset pressure, the compressor starts.

10.7. Check of adequate refrigerant quantity

Calculate the refrigerant quantity according to page 19 "6.4. Refrigerant charge".

Charge the 90% of the calculated amount.

When you confirm that the following operating conditions 1, 2 are met, please add the refrigerant to the 100% of the calculated amount.

1. In the operation at 5 minutes or more after starting the compressor, the subcooling degree (*1) must be 0°C or under.

*1 Subcooling degree = Medium pressure saturation temperature "C46" – "Liquid feed pipe temperature" "C15"

Calculated by 7 segment display C46: Medium pressure saturation temperature C15: Liquid feed pipe temperature

2. The aperture of EEVSC subcooling coil electronic expansion valve must be at the upper limit value.

Type	Upper limit value (pulse) of subcooling coil electronic expansion valve 7 segment display "C23"
OP-UPAC030COP04E	1 comp 240
	2 comp 470

Operation range

Use this condensing unit within the following operation ranges.

(Continuous rating)

Item	Unit	Specifications
Refrigerant	-	R744
Evaporation temperature	$^{\circ}\text{C}$	$-45 \sim +5$
Low pressure (LP)	bar abs	$8.3 \sim 39.7$
Suction gas temperature(Ts)	$^{\circ}\text{C}$	Evaporating temperature + 40°C
Discharge temperature(Td)	$^{\circ}\text{C}$	125 or under
Ambient temperature	$^{\circ}\text{C}$	$-20 \sim +43$
Power supply voltage	-	Within $\pm 10\%$ of rated voltage (380/400/415 V)
Voltage unbalance rate	-	Within $\pm 2\%$ of rated voltage

Note:

1. Provide sufficient insulations on liquid feed piping and suction gas piping. (Refer to the insulation (*) thickness in the following table.)

Type	OP-UPAC030COP04E	
	Liquid feed	Suction
Kind of pipe		
For cooling	30mm	40mm
For freezing	40mm	50mm

Note: Where the thermal conductivity of insulator is $0.035 \text{ W/m}\cdot\text{K}$, if the liquid feed pipe and the suction gas pipe touch each other, it could cause an overheat as a result of heat exchange between these pipes. Separate these pipes effectively.

2. Do not use the unit in corrosive atmosphere.
3. Arrange at site such that the degree of superheat of suction gas will fall within a range of 5 deg to 40 deg.

* Regarding the capacity of low pressure side device (show case, etc.) to be connected to the condensing unit, connect the device such that its total nominal capacity will become 50% or more of the rated capacity of the condensing unit.

11 – Operation

11.1. Oil check verification

Charge condensing unit oil according to "page 15, 6.1. Charge of condensing unit oil".

Check if adequate quantity of oil is retained, by the following refrigerating oil check operations.

Operation

1. Change the setting of compressor speed at the set value of 7-segment display "P19". (Initial setting 70rps $\times 2$) (For the detail of setting, see 9.2 Explanation of control on Page 27)
2. Operate all load units to be connected (show case and unit cooler).
3. Change the dipswitch SW4-6 OFF \rightarrow ON.
4. Operate the unit for 180 minutes in total with the compressor running at the set speed of "P19". Elapsed operating time of compressor (set speed of "P19") is indicated at 7-segment display. (The compressor may stop during operation depending on the condition of load unit.)
5. Should the operation of total 180 minutes be counted up without detecting by the oil level sensor any oil shortage (detection of oil shortage for 100 seconds continuously), "7-segment display" changes to "0". In this case, it is complete the oil quantity check.
When "7-segment display" has shown "Lo1" (means lack of oil in CM1) or "Lo2" (means lack of oil in CM2) or "Lo" (means lack of oil in both CM1 and CM2) in place of "0", in place of "0". All compressors are stopped because an oil shortage has been detected. In this case, turn the dipswitch SW4-6 to OFF and replenish the oil.
(Quantity of oil to be added at one time should be 500 cc as a guide.) After replenishing the oil, repeat from (1), 2 to check operation till "7-segment display" shows "0".

Instructions

11.2. Oil return operation

When the external input harness is inserted into the external input "CNS3" of the control board while the compressor is in operation and the rotational speed is less than the specified value (*1), the oil return control is immediately executed.

In the maintenance PC of the condensing unit, the compressor rotation speed CM1, the suction superheat degree, the indoor unit expansion valve opening degree, and the oil return control status are selected, and whether the expansion valve opening degree is opened by the oil return or not, the oil return control is normally completed (10 minutes end or end in time due to low superheat), and the oil return control status is confirmed.

Pattern for the number of running compressor	(*1)Oil Return operation Compressor set speed
1) 1 compressor	90 rps
2) 2 compressors	70 rps x 2 compressor

11.3. Operation check of protective device

Confirm that, if a protective device trips, an alarm is released and the unit stops by the error stop.

Out of various protective devices for the condensing unit, confirm here, as a representative example, if the error stop occurs when the thermistor error is raised forcibly.

1. Disconnect CNTH1 connector (Gas cooler temperature Tho-G1, G2 thermistor).
2. Turn on the power supply. (It can be confirmed for 20 seconds only at 10 minutes after starting operation.)
3. Confirm that it stops approx. 5 seconds later. (Alarm code "E-37" is displayed.)
4. Reinsert the removed CNTH1 connector as it was.
5. Reset the alarm code as follows.
 - Pressing SW8, SW9, change the 7-segment display to "P20", and press SW7 for 3 seconds or more.
 - Change from "0" to "1" with SW8.

The alarm code is reset.
If the external input P08 (CNS3) is set at "3: Error reset", it can be reset also externally. Make sure, however, to check the error code and remove the cause of error, before resetting.
6. Confirm that the operation restarts. (Alarm code "E-37" extinguishes.)
7. Clear the history of alarm code with "C96" and SW7
8. By the low pressure cut or turning "OFF" the breaker, end the operation confirmation (stop of condensing unit).

12 – Check with running unit

- Check the fan rotation direction. Air must flow from the condenser towards the fan.
- Check current draw and voltage.
- Check suction superheat to reduce risk of slugging.
- Respect the operating limits.
- Check all tubes for abnormal vibration. Movements in excess of 1.5 mm require corrective measures such as tube brackets.
- When needed, additional refrigerant in liquid phase may be added in the low-pressure side as far as possible from the compressor. The compressor must be operating during this process.
- Do not overcharge the system.
- Follow the local regulations for restoring the refrigerant from unit.
- Before leaving the installation site, carry out a general installation inspection regarding cleanliness, noise and leak detection.
- Record type and amount of refrigerant charge as well as operating conditions as a reference for future inspections.

13 – Guidance at delivery

When delivering the product to personnel who control daily use, explain about following items.

- Explain and instruct sufficiently about cautions as described on page 2 to 5 *Safety precautions*.
- Produce a check list for test run. Hand it over with explanation on the procedures of daily control of operation.
- Explain about ways of regular maintenance.
- Explain about measures to respond to activation of protective devices or accidental failure on operation. Inform the contact desk for such occasion.
- Explain the need to have professional after-sale services, and recommend to close the maintenance service (onerous) agreement.

14 – Maintenance

	Internal pressure and surface temperature are dangerous and may cause permanent injury. Maintenance operators and installers require appropriate skills and tools. Tubing temperature may exceed 100 °C and can cause severe burns.
	Ensure that periodic service inspections to ensure system reliability and as required by local regulations are performed.

To prevent system related problems, following periodic maintenance is recommended:

- Verify that safety devices are operational and properly set.
- Ensure that the system is leak tight.
- Check the compressor current draw.
- Confirm that the system is operating in a way consistent with previous maintenance records and ambient conditions.
- Check that all electrical connections are still adequately fastened.
- Keep the unit clean and verify the absence of rust and oxidation on the unit components, tubes and electrical connections.

Instructions

14.1. Maintenance and inspection

To personnel for daily operation and control

- The list shows contents of regular inspection and replacement guideline under general usage condition. The cycle of regular inspection is on an annual basis and it shows estimated cycle for component replacement and repair as the replacement guideline based on the result of the regular inspection. "Under the general usage condition" supposes 7 minutes of stop-start cycle and 5,000 running hours per year upon normal operational condition.
- Execute maintenance and inspection for load side (unit cooler and show-case) and module controller in accordance with criteria of load side and module controller.
In case that adjustment, maintenance and inspection for load side and module controller are not adequate, there is significant harmful effect on condensing unit.
- Condensing unit shall be utilized as putting in the system via on-site construction works like installation, refrigerant pipe work and electric work and so on. Since lifetime for failure and operation significantly depends on degree of right and wrong on construction works, criteria of construction works described on installation manual must be followed.

	Part	Inspection	Cycle	Guide for replacement
Refrigerant circuit parts	Compressor	High/medium/low pressure, vibration, noise, insulation resistance, loose terminal	1	40,000 h
	Air-side heat exchanger (Gas cooler)	High/medium/low pressure, fouled fin, discharge temperature	1	8 yr
	Solenoid valve	Operation, leak, clogging	1	7 yr
	Electronic expansion valve	Operation	1	7 yr
	Safety valve	Whether or not there is refrigerant leakage	1	5 yr
	Strainer	Strainer out-/inlet temp.	1	8 yr
	Capillary tube	Contact wear, vibration	1	8 yr
	Piping	Contact wear, vibration	1	8 yr
Electric circuit parts	Relay	Operation, contact/ insulation resistance	1	8 yr
	Solenoid valve, electronic expansion valve coil	Insulation resistance	1	8 yr
	Crankcase heater	Insulation resistance	1	20,000 h
	Fuse	Appearance	1	8 y
	PCB (Control, inverter)	Appearance	1	8 y
	High pressure breaker, pressure sensors	Contact resistance, capillary rubbing	1	8 y
	Terminal block	Looseness on terminal board	1	8 y
	Wring, connector	Disconnection, looseness, deterioration, rubbing	1	8 y
	Dielectric capacitor	No liquid leak, deformation allowed	1	8 y
	Cooling fan	Insulation resistance, noise	1	8 y
Electromagnetic switch (52C)	Contact resistance, operation	1	8 y	
Blower	Propeller fan	Balance, crack	1	8 y
	Fan motor	Insulation resistance, noise, vibration	1	20,000 h

14.2. When a protective device has tripped

To personnel for daily operation and control

- When the condensing unit is stopped by a protective device, consult your dealer or contact desk of maker. Report 1 Product model, 2 Alarm code content and 3 Condition of failure, referring to User guide, "Operation data sheet"

To service and maintenance personnel

- Upon receipt of a report on the trip of protective device and resulting stop of condensing unit, reconfirm whether it was operated within a proper operating range and did match the load capacity that of the condensing unit. For major items, refer to the following table.
- If the condensing unit or parts of refrigerant circuit have failed, take care of following points in order to prevent recurrence of the failure.
- Diagnose the cause in detail to identify the location and cause of failure.
- When repairing a leak from welding on pipe, make sure to recollect the refrigerant, and weld by passing nitrogen gas.
- When replacing the compressor, restore original formation on the suction, discharge pipes of compressor and the liquid injection pipe. If the formation is changed, it could cause cracks on pipes owing to vibration. Take care not to mistake on the wire connection of compressor (L1, L2, L3) to prevent reverse phase.
- When a part failed (including compressor), do not replace the while condensing unit, but replace defective part only.
- When disposing the condensing unit, make sure to collect the refrigerant beforehand.
- When the cause of failure is unknown, check the model of condensing unit, production No. and condition of failure, and report them to specified service company.

Instructions

<Protective device activation value>

Name	Symbol	Activation value
High pressure switch	63H1-1/63H1-2	High pressure \geq 140 bar
High pressure sensor	PSH	High pressure \geq 140 bar for 10 seconds
		High pressure \geq 120 bar for 10 minutes
Medium pressure sensor	PSM	If LP set value < Sensing Low pressure: Middle pressure \geq 80 bar
		If LP set value > Sensing Low pressure: Middle pressure \geq 76 bar
Discharge pipe temp. sensor	Tho-D1, Tho-D2	OP-UPAC030COP04E: Discharge pipe temp. \geq 140°C
Fuse (gas cooler motor)	CNDC1,2	4A for each Gas cooler fan motor

•If the load of load unit is too large or when the user has turned ON the condensing unit with the power supply to the load unit turned OFF, the condensing unit may repeat start and stop.

If such stops were repeated 120 times within 24 hours continuously, the 7-segment display indicates "oPE-11". Check the load condition.

"oPE-11" can be cancelled with the error inspection reset.

•Method of error inspection reset

When any error occurred, reset it as follows.

1. Remove the cause of error.

2. Change the display on the 7-segment display to "P20" by pressing SW8 and SW9, and press SW7 for more than 3 seconds.

3. Change from "0" to "1" with SW8. The error will be reset.

If the external input P08 (CNS3) is set at "3: Error reset", it can be reset externally.

Make sure, however, to check the error code and remove the cause of error before resetting.

If SW6-7 is turned to "ON", the warning "oPE-11" is not displayed.

•When total operation time of compressor has exceeded 30,000 hours since the last maintenance, the warning "oPE-03" is displayed to urge the user to request for maintenance. If this warning is displayed, you should prepare for maintenance.

•Where the active filter is installed, you can set the external input for the filter.

Adjust the 7-segment display to the code No. "PXX" which corresponds to the connector to which the active filter error is input, and adjust the setting item at "6: AF error" with SW8. If the active filter error signal is input in this condition, "oPE-30" is indicated on the 7-segment display. It does not stop constantly.

To set it at the constant stop, change the setting item from "6" to "7" with SW8.

External input connector name	Code No.	Data display range	Setting item
CNS3	P08	4:(Default) 0~20	0: External operation input
CNG1	P09	5:(Default) 0~20	1: Demand input
CNG2	P10	9:(Default) 0~20	2: Quiet mode input
			3: Error reset
			4: Compulsory oil return input
			5: Gas cooler fan snow control input
			9: Multistage demand input

Instructions

14.3. When error stop occurred

14.3.1. Maintenance code (oPE code)

If conditions corresponding to each item are met, the maintenance code (oPE code) is displayed on the 7-segment display. For details of display, refer to the following table.

7-segment display	Item	Remark
oPE-3	Total compressor operation time since last maintenance > 30,000 h	Synchronized with simplified remote monitor trigger timing
oPE-11	Number of the error detection stops within 60 min. after first stop [Low pressure error count (load side stop)] = 120 times	Synchronized with simplified remote monitor trigger timing
oPE-30	Active filter error detection	When it is not set at E63 display
oPE-64	Communication error detection between Controller and Condensing unit	Communication interrupted 10min. or more continuously
oPE-88	Compressor oil shortage detection	Oil level error is valid when SW6-5 and SW6-7 are OFF

14.3.2. Error code

If the unit is stopped fully by error, the code corresponding to error content is displayed on the 7-segment display. For details of display, refer to the following table.

7-segment Display	Error content	Cause	Inspection	Measures / countermeasures
E32	Power supply phase loss Power supply reverse phase	Phase loss (incl. under-voltage)	Volt check at 3-phase	Security of correct connection, power supply voltage
		Power supply reverse phase	See "10.2. Prevention of reverse phase operation" and change connection	
E36-1	Discharge pipe temp. error (Tho-D1)	Refrigerant gas shortage	Flash gas generation or no in sight glass	Additional refrigerant charge
		Liquid bypass circuit failure	Defective electronic expansion valve	Replace
E36-2	Discharge pipe temp. error (Tho-D2)	Refrigerant gas shortage	Flash gas generation or no in sight glass	Additional refrigerant charge
		Liquid bypass circuit failure	Defective electronic expansion valve	Replace
E37-1	Gas cooler temp. sensor No.1 error	Gas cooler temp. sensor broken wire, short-circuit are detected	Defective gas cooler temp. sensor, connector disconnection or short-circuit	Replace
E37-2	Gas cooler temp. sensor No.2 error			
E37-3	Middle pressure receiver inlet temp. sensor error	Middle pressure receiver inlet temp. sensor broken wire, short-circuit are detected	Defective middle pressure receiver inlet temp. sensor, connector disconnection or short-circuit	Replace
E37-4	Gas injection inlet temp. sensor error for Tho-INJ1	Injection inlet temp. sensor broken wire, short-circuit are detected	Defective injection inlet temp. sensor, connector disconnection or short-circuit	Replace
E37-5	Gas injection inlet temp sensor error for Tho-INJ2	temp. sensor broken wire, short-circuit are detected	Defective injection inlet temp. sensor, connector disconnection or short-circuit	Replace
E37-6	Subcooling coil temp. sensor error	Subcooling coil temp. sensor broken wire, short-circuit are detected	Defective subcooling coil temp. sensor, connector disconnection or short-circuit	Replace
E37-7	Liquid feed pipe temp. sensor error	Liquid feed pipe temp. sensor broken wire, short-circuit are detected	Defective liquid feed pipe temp. sensor, connector disconnection or short-circuit	Replace
E38	Outdoor air temp. sensor error	Out door air temp. sensor broken wire, short-circuit are detected	Defective outdoor air temp. sensor, connector disconnection or short-circuit	Replace
E39-1	Discharge pipe temp. sensor-1 error (Tho-D1)	Discharge pipe temp. sensor broken wire, short-circuit are detected	Defective discharge pipe sensor, connector disconnection or short-circuit	Replace
E39-2	Discharge pipe temp. sensor-2 error (Tho-D2)	Discharge pipe temp. sensor broken wire, short-circuit are detected	Defective discharge pipe sensor, connector disconnection or short-circuit	Replace
E40	63H1-1, 2 High pressure switch	Less air passing through gas cooler	Much dust on gas cooler	Wash, remove
			Clogged gas cooler suction inlet, blow outlet	Remove
		Low compressor speed	Fan speed controller failure	Replace parts
			Under overload state	High gas cooler suction air temp. High suction gas pressure (low pressure)
		Clogged high pressure side refrigerant pipe	Defective oil separator outlet check valve	Replace
E41-1	Power transistor overheat (CM1) (5 times in 1 hour)	Overheat of power transistor	Check the operation of the transistor cooling fan	Replace power transistor cooling fan or power transistor
		Stops with power transistor sensor broken wire, output error detection	Defective power transistor sensor, connector disconnection or short-circuit	Replace power transistor sensor

Instructions

7-segment Display	Error content	Cause	Inspection	Measures / countermeasures
E41-2	Power transistor overheat (CM2) (5 times in 1 hour)	Overheat of power transistor	Check the operation of the transistor cooling fan	Replace power transistor cooling fan or power transistor
		Stops with power transistor sensor broken wire, output error detection	Defective power transistor sensor, connector disconnection or short-circuit	Replace power transistor sensor
E42-1	Current cut (CM1)	Detect the anomalous output current of inverter	Check the inverter output	Replace inverter or compressor
			Compressor wiring, connector disconnection or short-circuit	Replace wiring or power transistor
E42-2	Current cut (CM2)	Detect the anomalous output current of inverter	Check the inverter output	Replace inverter or compressor
			Compressor wiring, connector disconnection or short-circuit	Replace wiring or power transistor
E43-1	Liquid return error (CM1)	The anomalous under dome temp.	Check the specification of connected low pressure devices	Connect the adequate low pressure devices
			Under dome temp. sensor, connector disconnection or short-circuit	Replace
E43-2	Liquid return error (CM2)	The anomalous under dome temp.	Check the specification of connected low pressure devices	Connect the adequate low pressure devices
			Under dome temp. sensor, connector disconnection or short-circuit	Replace
E45-1	Inverter-PCB transmission error (CM1)	Loose, blown, wrong wiring between condensing unit-controller	Wiring conductivity check Loose connection check Wire connection No. check	Replace wiring
		Defective PCB (Condensing unit PCB)	PCB check	Replace PCB
E45-2	Inverter-PCB transmission error (CM2)	Loose, blown, wrong wiring between condensing unit-controller	Wiring conductivity check Loose connection check Wire connection No. check	Replace wiring
		Defective PCB (Condensing unit PCB)	PCB check	Replace PCB
E48-1	DC fan motor No.1 error	Low fan speed is detected	Defective DC fan motor, connector disconnection or short-circuit	Replace DC fan motor or PCB
E48-2	DC fan motor No.2 error			
E49	Low pressure error	Low pressure is detected	Leakage of refrigerant	Repair the leakage
			Defective low pressure sensor, connector disconnection or short-circuit	Replace low pressure sensor
E51-1	Power transistor overheat (CM1) (continue for 15 min.)	Overheat of power transistor	Check the operation of the transistor cooling fan	Replace power transistor cooling fan or power transistor
		Stops with power transistor sensor broken wire, output error detection	Defective power transistor sensor, connector disconnection or short-circuit	Replace power transistor sensor
E51-2	Power transistor overheat (CM2) (continue for 15 min.)	Overheat of power transistor	Check the operation of the transistor cooling fan	Replace power transistor cooling fan or power transistor
		Stops with power transistor sensor broken wire, output error detection	Defective power transistor sensor, connector disconnection or short-circuit	Replace power transistor sensor
E53	Suction pipe temp. sensor error	Suction pipe temp. sensor broken wire, short-circuit are detected	Suction pipe temp. sensor, connector disconnection or short-circuit	Replace
E54-1	Low pressure sensor error	Stops with low pressure sensor broken wire, output error detection	Defective low pressure sensor, connector disconnection or short-circuit	Replace
E54-2	High pressure sensor error	Stops with high pressure sensor broken wire, output error detection	Defective high pressure sensor, connector disconnection or short-circuit	Replace
E55-1	Under dome temp. sensor error (Tho-C1)	Under dome temp. sensor broken wire, short-circuit are detected	Under dome temp. sensor, connector disconnection or short-circuit	Replace
E55-2	Under dome temp. sensor error (Tho-C2)	Under dome temp. sensor broken wire, short-circuit are detected	Under dome temp. sensor, connector disconnection or short-circuit	Replace
E56-1	Power transistor temp. sensor error (Tho-P1)	Power transistor temp. sensor broken wire, short-circuit are detected	Power transistor temp. sensor, connector disconnection or short-circuit	Replace
E56-2	Power transistor temp. sensor error (Tho-P2)	Power transistor temp. sensor broken wire, short-circuit are detected	Power transistor temp. sensor, connector disconnection or short-circuit	Replace
E58-1	Rotor position detection error (CM1)	Detection of the compressor rotor position.	Check the inverter output	Replace inverter or compressor
			Compressor wiring, connector disconnection or short-circuit	Replace wiring or power transistor
E58-2	Rotor position detection error (CM2)	Detection of the compressor rotor position.	Check the inverter output	Replace inverter or compressor
			Compressor wiring, connector disconnection or short-circuit	Replace wiring or power transistor

Instructions

7-segment Display	Error content	Cause	Inspection	Measures / countermeasures
E59-1	Compressor startup failure (CM1)	Compressor fails to startup.	Check the inverter output	Replace inverter or compressor
			Compressor wiring, connector disconnection or short-circuit	Replace wiring or power transistor
E59-2	Compressor startup failure (CM2)	Compressor fails to startup.	Check the inverter output	Replace inverter or compressor
			Compressor wiring, connector disconnection or short-circuit	Replace wiring or power transistor
E60-1	Middle pressure sensor error (PSM-1)	Stops with medium pressure sensor broken wire, output error detection	Defective medium pressure sensor, connector disconnection or short-circuit	Replace
E60-2	Middle pressure sensor error (PSM1-2)	Stops with medium pressure sensor broken wire, output error detection	Defective medium pressure sensor, connector disconnection or short-circuit	Replace
E60-3	Middle pressure sensor error (PSM2-2)	Stops with medium pressure sensor broken wire, output error detection	Defective medium pressure sensor, connector disconnection or short-circuit	Replace
E63	External input error stop	Stops with the external input	Check the connected devices	Replace wiring or repair the connected devices
E88-1	Oil level sensor error (CM1)	The oil level of compressor is not adequate	Check the quantity of oil with oil check operation	Additional refrigerant oil charge
E88-2	Oil level sensor error (CM2)	The oil level of compressor is not adequate	Check the quantity of oil with oil check operation	Additional refrigerant oil charge
E89	Communication error between CPU of control PCB	Communication between CPU is detected	Check the wiring surround the CPU	Repair wiring or replace PCB

•Method of error inspection reset

If any error occurred, reset it as follows.

1. Remove the cause of error.
2. Adjust the 7-segment display at "P20" with SW8, SW9, and press SW7 for more than 3 seconds.
3. Change from "0" to "1" with SW8.

The error will be reset.

Make sure, however, to check the error code and remove the cause of error before resetting.

* Error cannot be reset for 3 minutes after it occurred.

15 – Declaration of incorporation

•Pressure Equipment Directive 2014/68/EU

EN 378-2:2016 - Refrigerating systems and Heat Pumps - Safety and environmental requirements-Parts 2: Design, construction, testing, marking and documentation.

Low Voltage Directive 2014/35/EU EN 60335-1:2012 + A11:2014- Household and similar electrical appliances-Safety-Part 1: General requirements-for all above mentioned condensing units **Eco-design DIRECTIVE 2009/125/ EC**, establishing a framework for the setting of Eco-design requirements for energy-related products.

REGULATION (EU) 2015/1095, implementing Eco-design Directive 2009/125/EC with regard to Eco-design requirements for professional refrigerated storage cabinets, blast cabinets, condensing units and process Chiller.

• Condensing unit measurements are made according to standard "EN 13771-2:2017" – Compressor and condensing units for refrigeration-performance testing and test methods- part 2: Condensing units.

16 - Warranty

Always transmit the model number and serial number with any claim filed regarding this product.

The product warranty may be void in following cases:

- Absence of nameplate.
- External modifications, in particular, drilling, welding, broken feet and shock marks.
- Compressor opened or returned unsealed.
- Rust, water or leak detection dye inside the compressor.
- Use of a refrigerant or lubricant not approved by Danfoss.
- Any deviation from recommended instructions pertaining to installation, application or maintenance.
- Use in mobile applications.
- Use in explosive atmospheric environment.
- No model and serial number transmitted with the warranty claim.

Instructions

16.1 Scope not warranted

1. Nonconformity in the selection of model or design of condensing unit. When we judge that the failure has resulted from a fact that the installation work is made without observing instructions or cautions given in the instruction manual, or the condensing unit that has an excessively larger or smaller capacity is selected for the cooling load. (Example: Mistake in selection of expansion valve, improper installation, omission of solenoid valve in liquid line, etc.)
2. Nonconformity in the selection of low pressure device.
 - When the low pressure device doesn't meet the requirements described in [Page 9](#).
3. When any items other than the followings specified by us are used.
 - Refrigerant R744
 - Condensing unit oil "Diamond Freeze MA68"
4. Nonconformity in installation work
 - Damage caused by improper handling during installation work
 - When it is judged that foreign matters entered in the cycle during installation piping work.
 - When it is judged that electric wires have been connected improperly during installation.
 - When matters have not been improved although our supervisor warned improper practice during installation.
 - Accident resulted from violating relevant laws or regulations.
 - When it has been operated neglecting larger vibration or operating noise.
 - When the failure was caused by weak foundation or fragile support frame.
5. Accident resulted from modification, incidental work or relocation at site, or overriding protective devices provided on our product.
6. Accident resulted from installing on vehicle, rail car, ship, or other mobile carrier.
7. Accident resulting from nonconformity in operating environment, maintenance and inspection.
 - Accidents resulting from installation in the environment impregnated with corrosive gas such as oil (including machine oil), salt (coast area) and sulphide gas.
 - Accident related to installation place (shortage of air blow volume, special environmental conditions like hydraulic pressure, chemicals, etc.)
 - Accident caused by maladjustment (overheat degree of expansion valve, pressure switch setting at low pressure side).
 - Accident by short-cycle operation (operation and stop of less than 3 minutes each).
 - Improper maintenance (clogged gas cooler fins, overlooked inspection and cleaning of fouling, inspection and replacement of dirty condensing unit oil and gas leak).
 - Mistake in repair work (use of wrong parts, missing parts, improper installation).
 - Accident caused by overcharge or shortage of refrigerant or condensing unit oil (start failure, poor cooling of motor, improper lubrication).
 - Accident owing to insufficient defrosting.
 - Accident resulting from abnormal voltage, abnormal electromagnetic radiation, or other external factor like trapped insect.
 - When it is judged that air or moisture has been inhaled in the cycle.
8. Accident resulting from running out ranges of evaporation temperature, outdoor temperature, or voltage as specified for this product.
9. Accident caused by external factors such as fire, earthquake, storm or flood, thunderbolt, abnormal weather, other natural disasters, soot, ash, acid rain, etc.
10. Any other accidents are not warranted at all, including installation or use contradicting common practices in the installation, operation, adjustment or maintenance of the condensing unit. Also exempted from this warranty are consequential compensations for damage on cooled goods, or business interruption. It is recommended therefore to install an alarm system, or subscribe to a property insurance through our dealer in preparation for consequential accidents.

17 – Disposal



Danfoss recommends that condensing units and oil should be recycled by a suitable company at its site.

When the condensing unit is relocated and reinstalled after moving to new address, or other, specialized techniques are required. Consult your dealer or specified contact desk of maker.

When disposing the condensing unit, although it is not necessary to collect the refrigerant, consult your dealer or specified contact desk of maker.

Only for European Union and countries with recycling systems

This symbol on the products, packaging, and/or accompanying documents means that used electrical and electronic products must not be mixed with general household waste.

For proper treatment, recovery and recycling of old products, please take them to applicable collection points in accordance with your national legislation.

By disposing of them correctly, you will help to save valuable resources and prevent any potential negative effects on human health and the environment.





For more information about collection and recycling, please contact your local authority.

Penalties may be applicable for incorrect disposal of this waste, in accordance with national legislation.

Instructions

18 – Servicing

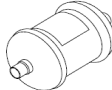
Accessories

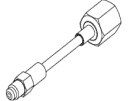
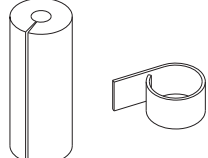
Name	Q'ty	Location of use	
Wiring 	3	Connect these to CNG1, 2 or CNS3 on the outdoor unit PCB when external inputs are used.	These are fixed in the control box with tapes. When using the wiring, refer to the "External input harness installation manual", page 49.
Wiring 	2	When using external outputs, cut the harness at the center to produce a pair of connectors, and connect them to CNH, CNY, CNZ1 and CNZ2 on the outdoor unit PCB.	These are fixed in the control box with tapes. When using the wiring, refer to the "External output harness installation manual", page 50.
Dryer 	1	Install in liquid pipe. Dryer pipe diameter need to reduce with reducer to connect liquid pipe.	This is fixed to unit base plate with tapes.
Reducer (for dryer) 	2	Connect to dryer pipe.	These are fixed to unit base plate with tapes.
Reducer (for service port) 	3	Using for airtight test and vacuuming. Connect to service port.	These are fixed to unit base plate with tapes. When using the reducer, refer to the page 14-15 of Instructions "5.1 - Leak detection" and "6 - Vacuum dehydration".
Pipe insulation and tape 	2	Attach on the section of bare pipe of suction for each compressor.	Plastic package (including 2 pieces of pipe Insulation and 2 pieces of tape) is implemented inside of Condensing unit. Before operation, there is bare pipe section (where Cushioning cardboard between compressor and pipe had been existed) for each compressor, therefore to attach 1 pipe insulation on the section of bare pipe not to generate the clearance from upper (existing) insulation and to fix with them with 1 tape (to perform totally 2 times) (Page 37)

Instructions

External Input Harness Installation Manual

The harnesses are used to control the operation of CO₂ refrigerating machine from external control panel (device).
(The "a" contact relay needs to be provided at site.)

CAUTION

- Have the harnesses installed by your dealer or specialized contractor.
- Electrical work must be made using dedicated circuit by qualified electricians.
- Source power supply to the CO₂ refrigerating machine and external control panel must be turned off before starting work.
- Carefully read the installation manual of CO₂ refrigerating machine, and observe the precautions.

External input harness (attached to the outside of control box) ... 3 pcs.

Brown ... For compulsory oil return control input (CNS3)

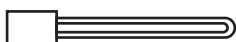

Blue ... For gas cooler fan snow control input (CNS1)

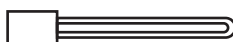

White ... For multistage demand input (CNG2)

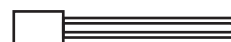

JST XAP-02V-1

* Harnesses for external operation input (CNS1) and demand input (CNS2) are fixed in the control box with tapes.

Installation procedure

1. Cut the harness, and attach a round terminal (provided at site) at the end, and connect to the relay.

*External input is input in the non-voltage contact (open or short-circuited). The relay is not necessary if the non-voltage contact output of control panel can be used.

2. Connect the connector to the control PCB of CO₂ refrigerating machine.

External input	Default setting: Function	7-segment: Setting value
CNS3 (Brown)	4: Compulsory oil return control input	P08 : 0 ~ 20
CNG1 (Blue)	5: Gas cooler fan snow control input	P09 : 0 ~ 20
CNG2 (White)	9: Multistage demand input	P10 : 0 ~ 20

Specifications of external input

Default functions of external inputs are as shown at right.

*Inputs use non-voltage contacts.

Functions can be changed from the default settings using the 7-segment display as follows.

* Setting values on the 7-segment display correspond to respective functions as shown at right

[Procedure to change external input function]

1. Using SW8, SW9, change the 7-segment display to the display (POO) of external input to be changed.

2. Hold down SW7 for 3 seconds to flicker the display, and change the setting value for function to be changed with SW8, SW9.

3. Hold down SW7 for 3 seconds to light the display.

This is all for the change of external input functions.

Setting value	Function	Open	Short-circuit
0	External operation input	Stop	Valid
1	Demand input	Valid	Valid
2	Quiet mode input	Invalid	Valid
4	Compulsory oil return input	Ordinary	Valid
5	Gas cooler fan snow control input	Ordinary	Valid
9	Multistage demand input	Invalid	Valid

*1 Demand input: P04

*2 Demand rate setting for multistage demand input: 0%, 40%, 60%, 80% PF22: OFF → 000 → 040 → 060 → 080, P14, P15

Instructions

External Output Harness – Installation Manual

The harnesses take out operation and error signals from CO₂ refrigerating machine.
(The 4-point unit relay needs to be provided at site.)

⚠ CAUTION

- Have the harnesses installed by your dealer or specialized contractor.
- Electrical work must be made using dedicated circuit by qualified electricians.
- Source power supply to the CO₂ refrigerating machine and external control panel must be turned off before starting work.
- Be sure to use the harnesses via the unit relay. Otherwise it could cause electric shock, or fire.
- Carefully read the installation manual of CO₂ refrigerating machine, and observe the precautions.

External input harness (attached to the outside of control box) ... 3 pcs.

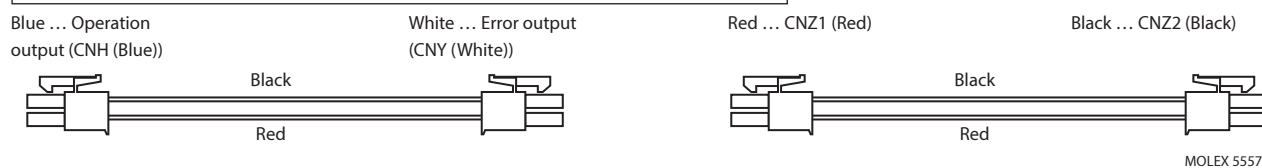

* Harness has connectors at both ends to prevent short-circuit by misconnection.

Installation procedure

1. Cut the harness at center to two pieces.
2. Attach a round terminal at end of each harness, and connect to the relay (provided at site)
3. Connect the connector to the CO₂ refrigerating machine control PCB.

Circuit diagram

* External output is "Plus common DC 12 V output". Coil resistance of contact relay must be 750Ω or higher.

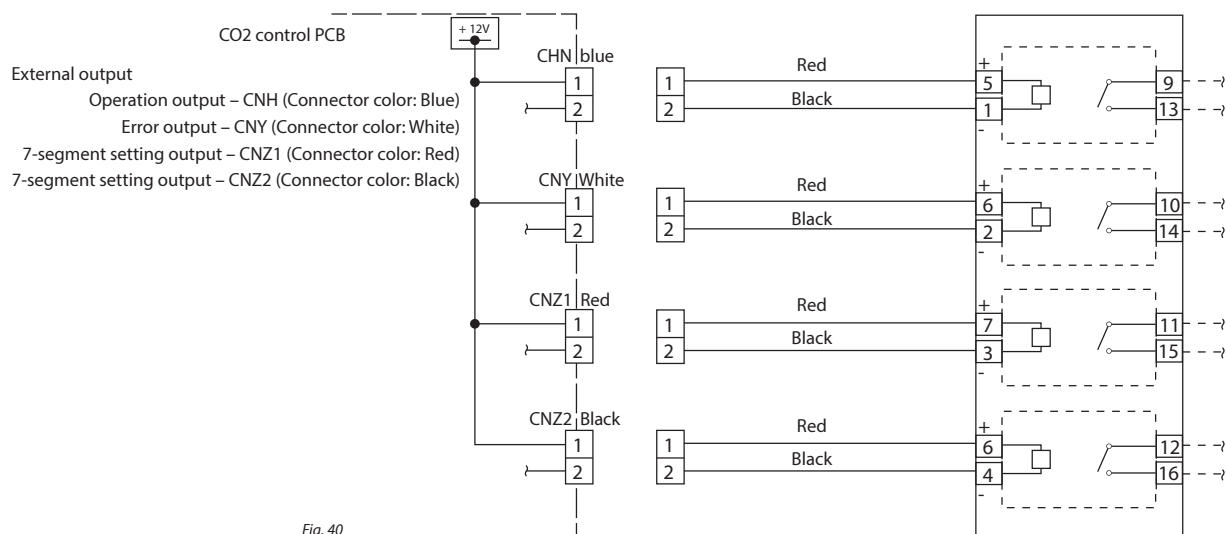

Fig. 40

<CNZ1, CNZ2 setting method>

External output Function assignment	Code No.	Default setting value
CNZ1	P05	2
CNZ2	P06	4

· P05, P06 setting value

Setting value	Function	Setting value	Function
0	Operation output	5	High pressure control output
1	Error output	6	Compressor operation time (Maintenance time) time-over output
2	Compressor ON output	7	Spare (Spare setting to be same as default setting.)
3	Fan ON output	8	Spare (Spare setting to be same as default setting.)
4	Oil return operation output	9	Spare (Spare setting to be same as default setting.)

Instructions

Annex A - Technical data

Nameplate

A	OP-UPAC030COP04E		
B	114X6005		
		MADE IN JAPAN	
C	Application	UBP	IP24
D	Refrigerant	R744	PED Category III
	PS _{HP}	140 bar	PT _{HP} 140 bar
E	PS _{LP/MP}	80 bar	PT _{LP/MP} 80 bar
	TS	-20 / 43 °C	
F	Voltage	400V 3N~50Hz	RLA 38.0 A
	MCC	40.0 A	
	OIL INSIDE	POE Diamond Freeze MA68	
G	Serial No.	*****	
	EAN No.	5702424686109	
			MANUFACTURING DATE 2023
			LCA011F007C
	Danfoss Ltd., 22Wycombe End, HP9 1NB, GB		Danfoss A/S, 6430 Nordborg, Denmark

NOTES

The CO₂ refrigerant (R744) is used for this unit. Pressure of CO₂ refrigerant is 14MPa at the maximum.
For using this unit properly and safety, please read the instruction manual and the installation manual carefully before use.
For installing or servicing this unit, be sure to ask qualified professionals to do it.

WARNING

System contains refrigerant under high pressure. Do not temper with the system. It must be serviced by qualified professionals only.
Consider measures not to exceed the critical concentration of refrigerant in the event of leakage especially when it is installed in a small room. If the concentration of CO₂ exceeds 0.1%, it may affect the human body.
When servicing this unit with the brazing work, be sure to discharge any CO₂ refrigerant and nitrogen gas for air tightness test that may be remaining inside, before starting the brazing work. The high pressure in the circuit becomes extremely high by the rapid rise of temperature and it may cause burst or serious injury.
Be sure to charge the CO₂ refrigerant with 99.95% of purity with using the dedicated gauge manifold for CO₂ refrigerant. If the air is mixed in, the high pressure in the circuit becomes extremely high and it may cause burst or serious injury.

- A:** Model
- B:** Code number
- C:** Application, Protection
- D:** Refrigerant
- E:** Housing Service Pressure (Maximum working pressure)
- F:** Supply voltage, Rated Load Ampere, Maximum Continuous Current
- G:** Serial Number and bar code

Condensing unit installation place (Service space)

Single unit installation

Installation examples

I : Case of access from only back side of Refrigerating machine
 II : Case of access from back side and side of Refrigerating machine
 III: Case of cabling the power cable from the L2 side (other is same as example I)

Please refer page 53 for detailed information

Installation Example	I	II	III
L1	800	800	800
L2	10	10	330
L3	800	800	800
L4	100(*)	500	100(2)
H1	1500	1500	1500
H2	Not limited	Not limited	Not limited
H3	1000	1000	1000
H4	Not limited	Not limited	Not limited
H5	2000	2000	2000

(*) A service space of 800mm minimum is necessary if installed in series. More than 800 mm is nice to have to inspect or replace parts of the condensing unit.

Take care not to interfere with the service space during piping work. Where the necessary space is not available, install a stand to run the piping under the unit.

(*)1 Be sure to keep more than 100mm spaces when the unit contacts with a wall. If the unit installed in succession, 10mm spaces is enough.

(*)2 A space of 330mm is necessary when the power cable is taken in from L2 side, where units are installed in series.

(3) Be sure to keep enough service spaces of more than 800mm in front of the unit service panel for easy inspection of the unit and replacement of components (In case of Example II, for service space of back side 500mm or more are necessary).

Instructions

Designation system for the Optyma™ iCO2 range

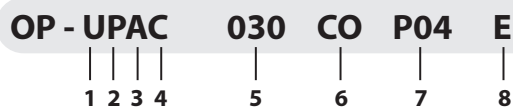

1 Application: U = Universal (MBP & LBP)
2 Condensing unit family: P = Optyma™ iCO2
3 Refrigerant: A = R744 (CO2)
4 Gas cooler type C = Fin and tube heat exchanger
5 Compressor Displacement in cm³: Example 030 = 30 cm ³
6 Compressor platform CO = Two stage Rotary & Scroll compressor
7 Version: P04: Optyma™ Plus iCO2 standard version with dedicated accessories for CO2 refrigerant.
8 Electrical code: E = Compressor 133–308V 3-phase & Fan DC 280/339V

Version control

Model	Optyma™ iCO ₂
Version	(P04)
Condensing unit: IP level	IP24
Refrigerant	R744 / CO ₂
Compressor technology	2 stage – Scroll+Rotary
Control box (pre-wired E-panel)	Yes
Fin and Tube condenser	Yes
Fan speed controller	Yes
Main switch (circuit breaker)	Yes
Filter drier	Yes
Sight glass	Yes
Crankcase heater	Yes
HP Switch	Auto/Manual reset mode
Acoustic insulation	Yes
Condensing unit electronic controller	Yes
Network connectivity	Yes
Stack mounting	Not possible
Oil separator	Yes
Discharge gas Temperature Sensor	Yes
Suction gas Temperature Sensor	Yes
Ambient Temperature Sensor	Yes
HP/LP Alarm	Yes
Injection kit	Premounted
Adjustable time delay (Compressor)	Yes (available in Controller)
Electronic Expansion Valve	Yes
Solenoid valve	Yes
Receiver	Yes
Service valves	Yes
Accumulator	Yes
Oil separator	Yes
Subcooling coil	Yes
Pressure relief valve	Yes
Stop valve	Yes
Check Valve	Yes

Instructions

Annex B - PID and GA

Dimensions and specifications table

Installation examples

I : Case of access from only back side of Refrigerating machine
 II : Case of access from back side and side of Refrigerating machine
 III: Case of cabling the power cable from the L2 side (other is same as example I)

Installation Example	I	II	III
L1 (3)	800	800	800
L2	10	10	330
L3 (3)	800	500	800
L4	100(1)	500	100(2)
H1	1500	1500	1500
H2	Not limited	Not limited	Not limited
H3	1000	1000	1000
H4	Not limited	Not limited	Not limited
H5	2000	2000	2000

(1) Be sure to keep more than 100mm spaces when the unit contacts with a wall. If the unit installed in succession, 10mm spaces is enough.
 (2) When pulling the power cable from the L2 side in succession installation, 300mm space is required.
 (3) Be sure to keep enough service spaces of more than 800mm in front of the unit service panel for easy inspection of the unit and replacement of components (In case of Example II, for service space of back side 500mm or more are necessary).

1. All dimensions are in mm
 2. Dimensions are not to scale

Item	Unit	Specifications	
Refrigerant	-	R744	
Evaporation temperature range	°C	-45 ~ +5	
Ambient temperature range	°C	-20 ~ +43	
Power supply voltage	-	3-phase, 380/400/415 V, 50 Hz	
Compressor	Nominal output	kW	15.2kW (7.6kW/unit × 2 unit)
	Start current	A	5A (Inverter start) × 2 unit
	Operating frequency	rps	40 ~ 104
Condensing unit oil type	-	Diamond Freeze MA68	
Gas cooler	Type	-	Plate-fin-tube type
	Blower type	-	Axial flow type (Motor direct connection)
	Blower rated output x Units	W	386W × 2 units
Accumulator, internal volume	L	11.0L (Liquid phase maximum capacity 10L)	
Medium pressure receiver, internal volume	L	19.8L/ unit × 1 unit (Liquid phase maximum capacity 18.7L)	
Protective device	-	High pressure switch, over-current protection Power transistor overheat protection, abnormal high pressure protection	
Product weight	kg	448	

(*) Stated as the rated output of compressor motor
 Rated speed at freezing or refrigeration, whichever is larger, is taken.
 OP-UPAC030COP04E ... Rated speed 104 rps

Instructions

Structural drawing

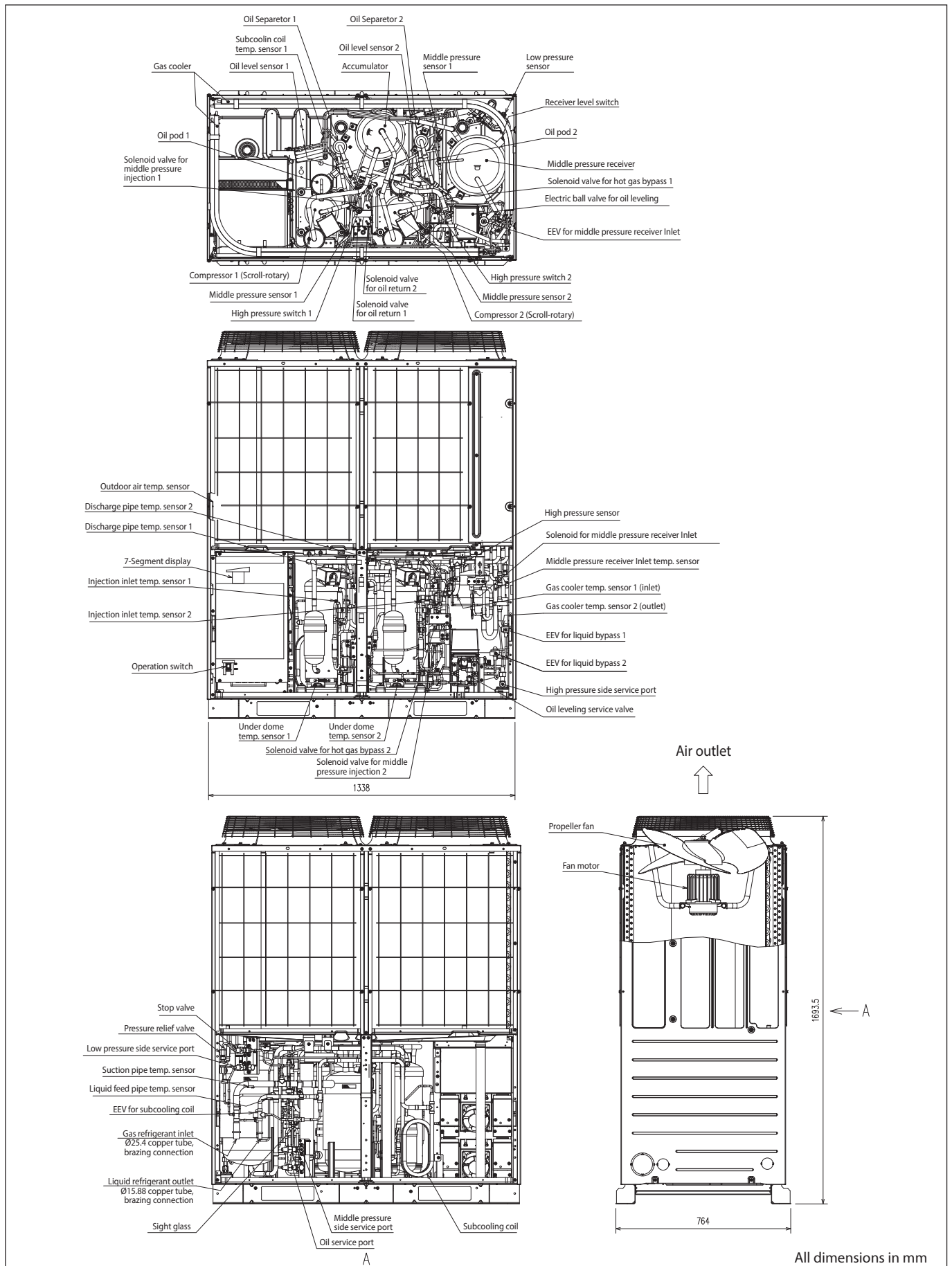

Instructions

Rated Specifications

Item	Rating	Unit
Power source	3-phase, 380/400/415 V, 50 Hz	V
Power input	23.78/23.78/23.78	kW
Current	40.0/38.0/36.6	A

Conditions

1. Evaporating temperature: -10 °C
2. Ambient temperature: 32 °C
3. Suction superheat : 10K

Performances (380 V / 400 V / 415 V)

Model : OP-UPAC030COP04E					
Refrigerant fluid : R744					
Ambient Temperature	Parameter	Symbol	Values		Unit
	Evaporating temperature	t	-10	-35	°C
	Annual electricity consumption	Q	67039	83679	kWh/a
	Seasonal Energy Performance Ratio	SEPR	3.40	1.72	
32 °C	Rated cooling capacity	P _A	37.12	19.29	kW
	Rated power input	D _A	23.78	20.04	kW
	Rated COP	COP _A	1.56	0.96	
25 °C	Rated cooling capacity	P _B	33.27	18.29	kW
	Rated power input	D _B	16.67	14.88	kW
	Rated COP	COP _B	2.00	1.23	
15 °C	Rated cooling capacity	P _C	27.77	16.86	kW
	Rated power input	D _C	8.61	10.10	kW
	Rated COP	COP _C	3.23	1.67	
5 °C	Rated cooling capacity	P _D	22.27	15.43	kW
	Rated power input	D _D	4.45	7.50	kW
	Rated COP	COP _D	5.00	2.06	
43 °C	Rated cooling capacity	P ₃	27.61	15.54	kW
	Rated power input	D ₃	20.50	19.19	kW
	Rated COP	COP ₃	1.35	0.81	
	Capacity control		Variable		

Sound pressure level

The A-weighted sound pressure level does not exceed 70 dB(A).
(at a distance of 1 m from surface of product)

Reference Information

Unit Internal refrigerant piping system design condition

Item	Unit	Specifications
HP piping system	Design pressure	140 bar
	Design temperature	140 °C
MP piping system	Design pressure	80 bar
	Design temperature	50 °C
LP piping system	Design pressure	80 bar
	Design temperature	50 °C

Instructions

PID

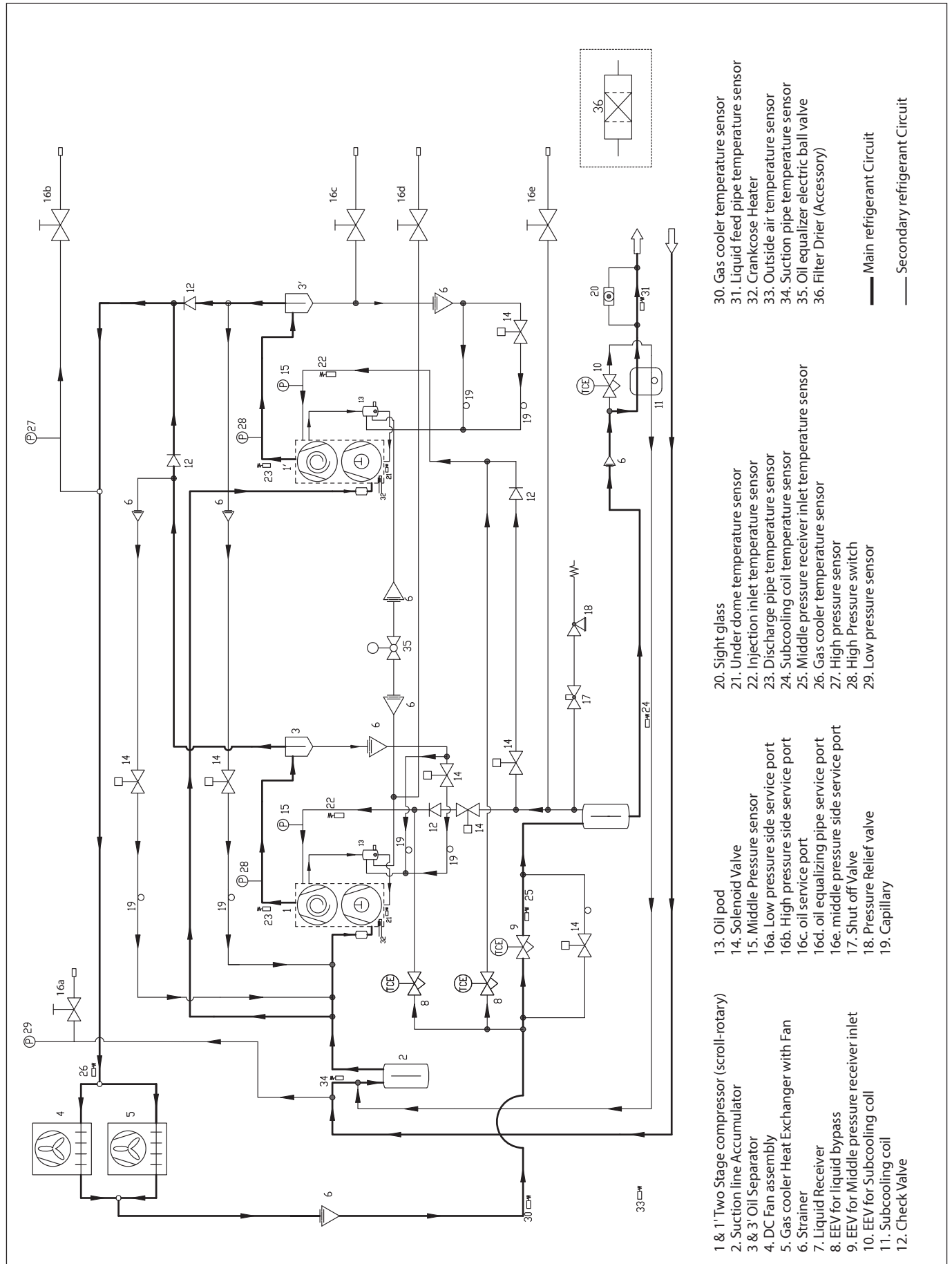

Instructions

Annex C - Wiring diagram

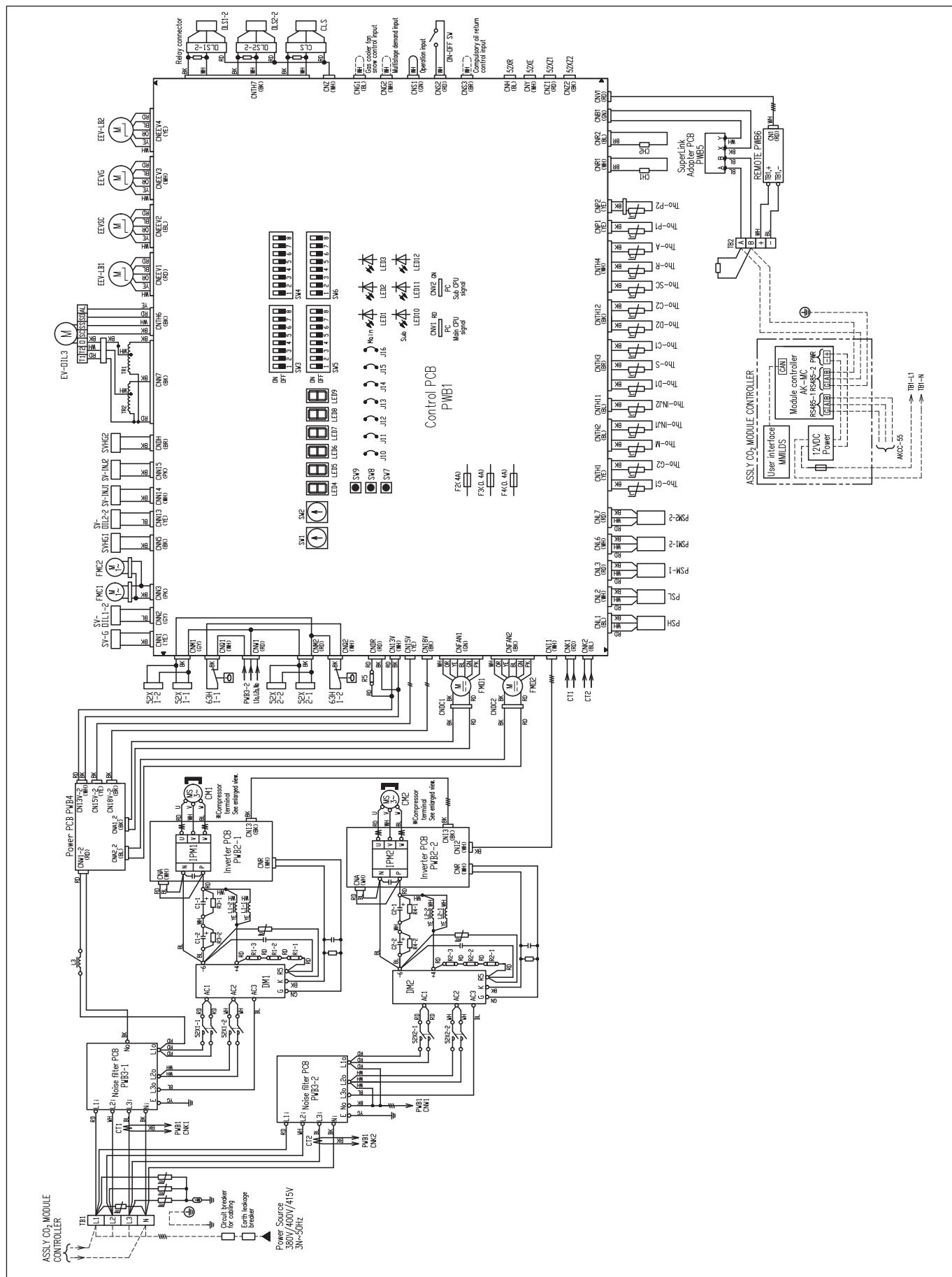

Instructions

Symbol	Name
C1,1,2 C2-1,2	Electrolytic capacitor
CH1,2	Crankcase heater
CLS	Receiver level switch
CM1,2	Compressor motor
CNA-Z	Connector
CT1,2	Compressor current
DM1,2	Diode module
EEVG	EEV for middle pressure receiver inlet
EEV-LB1,2	EEV for liquid bypass
EEVSC	EEV for subcooling coil
EV-OIL3	Electric ball valve for oil leveling
F	Fuse
FMC1,2	Inverter cooling fan
FMO1,2	Fan motor
IPM1,2	intelligent power module
J10	Spare
J11,12	Power supply, voltage switching
J13	External input signal type switching
J14~16	Spare
L1-1,2	DC reactor
L2-1,2	DC reactor
L3	DC reactor
TR1,2	AC Transformer
LED1	Main, inspection (red)
LED2	Main, normal (green)
LED3	Main, service (green)
LED4~6	7-segment LED (function display)
LED7~9	7-segment LED (data display)
LED10	Sub, normal (green)
LED 11	Sub, inspection (red)
LED 12	Sub, service (green)
OLS1-2, 2-2	Oil level sensor
ON-OFF SW	Operation switch
PSH	High pressure sensor
PSL	Low pressure sensor
PSM-1	Middle pressure sensor
PSM-1-2, 2-2	Middle pressure sensor
PWB1~6	Printed wiring board
R1~5	Inrush suppression resistance
SV-G	Solenoid valve for middle pressure receiver inlet
SVHG1,2	Solenoid valve for hot gas bypass
SV-INJ1,2	Solenoid valve for gas injection
SV-OIL1-2	Solenoid valve for oil return

Symbol	Name
SV-OIL2-2	Solenoid valve for oil return
SW1	Compressor low pressure control setting (10s)
SW2	Compressor low pressure control setting (1s)
SW3-1	Spare
SW3-2	Automatic backup operation
SW3-3	Spare
SW3-4	Protection start II cancel
SW3-5	Gas cooler fan control
SW3-6~8	Spare
SW4-1~4	Model selection
SW4-5,6	Spare
SW4-7,8	Compressor stop pressure setting
SW5-1~3	For target middle pressure adjustment
SW5-4,5	Spare
SW5-6~8	Pressure check operation mode
SW6-1~3	Spare
SW6-4	Presence of subcooling suppression control
SW6-5	Oil level error/oPE display switching
SW6-6	Presence of regular inspection and maintenance contract
SW6-7	Oil level error
SW6-8	Spare
SW7	Data erase/write
SW8	7-segment display (1s)
SW9	7-segment display (10s)
TB1,2	Terminal block
Tho-A	Outdoor air temp. sensor
Tho-C1,2	Under dome temp. sensor
Tho-D1,2	Discharge pipe temp. sensor
Tho-G1	Gas cooler temp. sensor 1 (inlet)
Tho-G2	Gas cooler temp. sensor 2 (outlet)
Tho-INJ1,2	Gas injection inlet temp. sensor 1
Tho-M	Middle pressure receiver inlet temp. sensor
Tho-P1,2	Power transistor temp. sensor
Tho-R	Liquid feed pipe temp. sensor
Tho-SC	Subcooling coil temp. sensor
Tho-S	Suction pipe temp. sensor
52X1-1,2	Magnetic contactor for CM
52X2-1,2	Magnetic contactor for CM
52XR	Operation output
52XE	Error output
52XZ1	External output 1
52XZ2	External output 2
63H1-1,2	High pressure switch

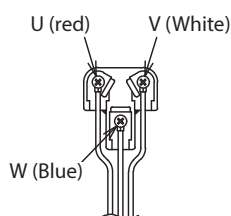

※ Enlarged drawing of compress terminals

Notes

- This drawing shows the electrical circuit of CO₂ condensing unit.
- Dotted line (----) shows the wiring on site.
Long dashed double-short dashed line (----) shows installation on site.
- Separate signal line from power line.
- CNG1,CNG2,CNS1,CNS2 and CNS3 are no voltage contact inputs.
If they will be used, use the attached harness for level input.
- Output of CNH,CNY,CNZ1 and CNZ2 is 12V. Maximum current is less than 20mA (+ side (1 PIN side) is common) .
If they will be used, use the attached harness and be sure to connect to unit relay (Coil resistance of 750Ω or more provided on site).
- Connect the A and B terminals of the TB2 to ASSLY CO2 MODULE CONTROLLER.

Instructions

Annex D - Outline of installation

Flow of installation work and points to note during installation

<Refrigerant piping work, airtight test, vacuum drying and additional refrigerant charge>

Point to note

1. Conventional R410A application products are absolutely incompatible with R744 application products.
2. Replace all measuring instruments and tools directly in contact with the refrigerant with those special to R744.

Care must be taken not to mistake materials, measuring instruments and tools in use.

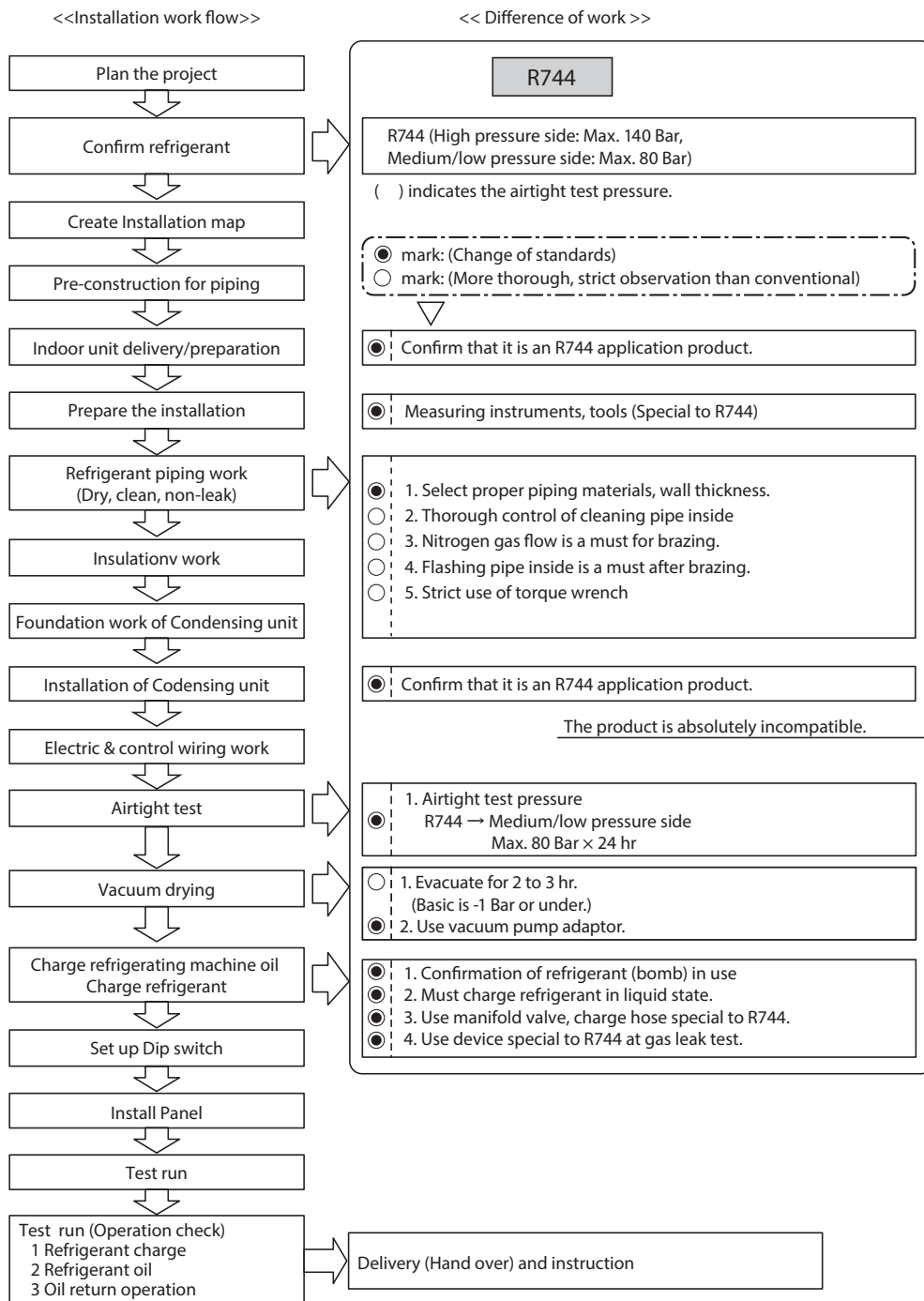

Instructions

Annex E - Outline of refrigerant

Outline of the refrigerant R744

R744 is an environmentally friendly refrigerant with the ozone depleting coefficient at "0" and a smaller global warming potential. Refrigerant R410A is comparable with this in terms of the ozone depleting coefficient but has a higher global warming potential. R744 has a higher pressure of 64 bar under ordinary temperature, which is approx. 4 times higher than 16.5 bar of R410A.

Following shows physical properties and saturated vapor pressure of R744. It should be noted that products using R744 refrigerant are not compatible with those using Freon gas. When installing a product, check the equipment nameplate, or the like, for applicable kind of refrigerant.

Note on R744

Judgment of R744 application products

R744 application products are notified so on their nameplates.

It should be remembered that they are not compatible with products that use Freon gas.

Characteristics of R744 refrigerant

Physical properties and saturated vapor pressure of R744 are as shown in Table 1.

Table 1 - Physical properties and saturated vapor pressure of R744

Item	CO ₂ (R744)	R410A
Composition	CO ₂	R32/R125 (50/50) Pseudo azeotropic refrigerant mixture
Ozone depleting coefficient	0	0
Global warming potential	1	2090
Saturated vapor pressure (bar, absolute pressure)	-20°C	0.04
	0°C	0.80
	20°C	1.44
	25°C	1.65
	30°C	1.88
Boiling point (°C)	-78.5	-51.4
Critical temperature (°C)	31.0	71.4
Critical pressure (bar, absolute)	73.8	49.0

Source: NIST Refprop9.0, 4th IPCC Report 2007

Use condensing unit oils recommended by Danfoss.

Synthetic oil (ester oil) compatible with R744 is used.

Instructions

Annex F - Check list Installation checklist

Date: / /

		Criteria	Result	Comment
1. Details				
1.01	Name	-		
1.02	Company	-		
1.03	Type of Installation (e.g. refrigerated warehouse, supermarket and convenience store)	-		
1.04	Site Name	-		
1.05	Site Address	-		
1.06	Is this the first system design and installation using Danfoss Condensing unit?	-		
1.07	Have you designed the system and selected the equipment yourself?	-		
1.08	Do you require support with system design from Danfoss?	-		
1.09	What is the system application? (i. e. cold rooms, cabinets, LT or MT etc.)	-		
2. Installation				
2.01	Record Condensing unit Model & Serial number on the data plate?	Write the Condensing unit serial number in the result column.		
2.02	Record Condensing unit software version. (Refer the label of CPU on Control PWB)	-		
2.03	Is the Condensing unit suitable installed with fixing bolts and anti-vibration mounting blocks?	Follow the installation manual		
	Is the Condensing unit installed level?	Check with level gauge Yes/No		
	Is the Condensing unit installed on a suitable base?	Check foundation strength		
	Is the Condensing unit installed near any oil and/or hazardous gases? Eg Sulphide gas	Yes/No		
	Is the Condensing unit installed in an area, where there are combustible gases and/or flammable substances near the units?	Yes/No		
	Is the Condensing unit installed in a cold ambient region? Have any additional measures been taken? Eg. snow hoods, mounting stand	Check measure		
	Confirm sections "4- Cautions for Installation" and "2 – Handling and storage/Delivery", Were followed correctly?	Yes/No		
2.04	Is there sufficient space for for airflow around the surface area of gas cooler?	Be sure to follow the installation manual "4 Installation / Selection of installation place".		
2.05	Is there sufficient service space at the front and back of the condensing unit?	Be sure to follow the installation manual "4 Installation / Selection of installation place".		
2.06	Is the height difference between indoor unit and Condensing unit (CDU) within specification?	Indoor unit is higher than CDU; ≤5m Indoor unit is lower than CDU ; ≤22m Be sure to follow the installation manual "3 Installation precautions/Typical installation".		

Instructions

		Criteria	Result	Comment
2.07	Is the piping length between indoor unit from Condensing unit within specification?	The distance between the farthest indoor unit and the condensing unit is 100 m or less. (Follow the Maximum refrigerant charge quantity at the same time shown in "5 Leak detection and 6 Vacuum dehydration")		
2.08	Location of Condensing unit(s). (pictures required)	-		
3. Electrical/Wiring				
3.01	Is earth leakage breaker (ELB) installed?	Fill in whether the ELB is present or not		
3.02	Is capacity of earth leakage breaker (ELB) appropriate?	Rated sensitivity current: 50mA (operation time < 0.1 sec) Rated current: 50A		
3.03	Are earth wires installed?	Fill in whether the earth wire is present or not		
3.04	Are terminal screws tightened with torque securely?	M4 1.0 – 1.3 / M5 2.0 – 2.5 M6 4.0 – 5.0 / M8 9.0 – 11.0 M10 18.0 – 23.0 (Unit: N.m)		
3.05	Insulation check between power terminal (400V circuit) and ground	> 1MΩ		
3.06	Is wiring capacity appropriate?	At least 16mm ² (L1,L2,L3), 25mm ² (N)		
	Is the power supply breaker rating, selection of earth leakage breaker and wire sizing conform to the local national standards?	Yes/No		
3.07	Isn't there reverse phase, phase loss?	no reverse phase and no phase loss		
3.08	[L1-L2/L2-L3/L3-L1/L1-N/L2-N/L3-N = / / / / / V]	Fill in the voltage		
3.09	Is the power supply balanced?	less than 2%		
3.10	Is below dip switch setting of control board or interface board same as below? SW4-6 of control board (Oil check operation mode select): OFF SW5-7 of control board (Airtight test mode select): OFF SW3-4 of interface board (Connecting Module controller select): ON	Yes/No		
4. Design-Refrigeration components				
4.01	Required room/ cabinet temperature.	Fill in the required temperature		
4.02	Design SST (Dew point)	SST usage: -45°C ~ 5°C		
4.03	Is the ambient temperature within the operating range?	ambient temperature usage range: -20°C ~ 43°C		
4.04	What is the total load unit capacity. What is the minimum operated load unit capacity.	Write the total capacity of load units. Minimum operating capacity should be over the 50% of the capacity of the condensing unit.		
4.05	Provide cold room or cabinet sizes?	Write the approximate cold room or cabinet size.		
4.06	How many evaporators are connected to the Condensing unit? Is the maximum number of indoor connections within specification?	Indoor unit up to 16 units.		
4.07	Evaporator / cabinet details (i.e. LuVe or Searle etc.)	Write the information of the evaporator/ cabinet detail		
4.08	Is the piping flow speed, for each indoor Evaporator within the oil return specification?"	Write the minimum flow rate (m/s) "4-Installation / Selection of installation place"		
4.09	Provide photos of system configuration and set up of the refrigeration system?	-		

Instructions

		Criteria	Result	Comment
4.10	Is Danfoss specified evaporator controller installed?	Danfoss Condensing unit specifies Danfoss AK-CC55 as the indoor unit controller. (Danfoss: 084B4083)		
4.11	Does change the parameter code in AKCC-55 from default?	Change the parameter from default		
4.12	Is external monitoring installed?	Write the information of the external monitoring.		
4.13	What is the provided valve type? (manufacturer & model)	Write the EEV model Danfoss Condensing unit specifies Danfoss AKV series as the expansion valve.		
5. Module Controller				
5.01	Is Danfoss specified module controller installed?	Write the model number and serial number of module controller.		
5.02	Is Danfoss specified or user interface (Danfoss: MMILDS) installed? Is remote controller set according to installation manual?	Follow the installation manual (Danfoss: 118A5494A, 118A5922A)		
5.03	Confirm the address No. of condensing unit and address NO. of AK-CC55 (indoor unit controller) on remote controller or user interface.	Write the address Follow the installation manual (Danfoss: 118A5494A, 118A5922A)		
6. Piping				
6.01	Write the piping configuration between the condensing unit and load unit (Refer 2.07)	The distance between the farthest load unit and the condensing unit is 100m or less. (Follow the Maximum refrigerant charge quantity at the same time shown in "5 Leak detection and 6 Vacuum dehydration")		
6.02	Pipe sizes. (liquid & gas)	Write the liquid and gas pipe size / Or piping diagram		
	Is there any trouble with piping connection, piping length and/or route of the pipework?	Follow the installation manual Provide a downward slope(1/200 or 1/250) at the sidewise run of suction pipe. Install the liquid solenoid valve just before the expansion valve. Yes/No		
	Is piping insulation work done correctly?	Follow the installation manual Avoid direct contact between suction and liquid pipes without insulation material. Yes/No		
6.03	Is the installation position of the evaporators above the Condensing unit? The tip of the reverse trap should be set higher than the level of the evaporator so that liquid refrigerant in the evaporator does not flow into the condensing unit after stopping.	Installation of the trap follows the "3 Installation precautions/Typical instillation"		
6.04	Is the height of the Condensing unit more than the indoor unit. Is the height difference within 22m? Oil trap should be installed every 5m to ensure correct oil return.	Installation of the trap follows the "3 Installation precautions/Typical instillation"		
6.05	Is this diameter in the vertical riser part of the Gas pipe limited to use Ø19.05 (t1.4)?	Installation of the trap follows the "3 Installation precautions/Typical instillation"		

Instructions

		Criteria	Result	Comment
7. Replenishment refrigerating oil /Refrigerant charge				
7.01	When the system was on a vacuum, What was the vacuum pressure achieved?	-1.0 bar or less		
7.02	How much the additional oil amount did you calculate according to the installation manual? (cc)	Follow the oil amount shown in the installation manual. " 5 Leak detection and 6 Vacuum dehydration / 6.1. Charge of condensing unit oil"		
7.03	Is the total oil charge less than maximum oil quantity?	Follow the oil amount shown in the installation manual. " 5 Leak detection and 6 Vacuum dehydration / 6.1. Charge of condensing unit oil"		
7.04	How much the additional oil amount did you charge actually? (cc)	Follow the oil amount shown in the installation manual. " 5 Leak detection and 6 Vacuum dehydration / 6.1. Charge of condensing unit oil"		
7.05	How much the refrigerant amount did you calculate ? (g) (Instruction/Installation manual "Refrigerant charge")	Follow the refrigerant amount shown in the installation manual. " 5 Leak detection and 6 Vacuum dehydration / 6.1. Charge of condensing unit oil"		
7.06	How much the refrigerant amount did you charge? (g) (The operation starts at 90% of the calculated amount of the refrigeration.)	Follow the refrigerant amount shown in the installation manual. "10 Procedure and caution for commissioning/ 10.7 Check of adequate refrigerant quantity".		
8. Test run (check the refrigerant amount)				
8.01	Record the "Operation data check sheet" each time you add the refrigerant.	Follow the refrigerant amount shown in the installation manual. "10 Procedure and caution for commissioning/ 10.7 Check of adequate refrigerant quantity".		
8.02	Have you recorded the refrigerant charge on the condensing unit label?	-		
8.03	Are there any deformation, scratches and/or dents on the unit surface?	Check unit surface	Yes/No	
8.04	Are there any error stop conditions?	Check the history of error stops	Yes/No	
8.05	Are the fan motor blades operating correctly?	Check stable rotation	Yes/No	
8.06	Is the discharge gas temperature with range?	Discharge Pipe temp. <125 Deg.C : Normal operation range		
8.07	Is there any short cycling of gas cooler exhaust air? Check temperature difference between actual outdoor air temperature and 7 segment display CO2: Outdoor air temperature (Tho-A)	<5°C		
8.08	Are there any anomalous sound and/or vibration?	Audible and visual check	Yes/No	

Instructions

Commissioning check sheet

Item 1. ~8. in the commissioning check sheet is the same as in the Design check sheet. This item (1.~8.) is omitted in this manual.

Date: / /

		Criteria	Result	Comment
9. Test run (Refrigerant oil check operation)				
9.01	Confirm oil check operation without "OIL-Lo" indication on 7 segment display	Follow the oil check operation shown in the installation manual. "11 Operation / 11.1 Oil check verification".		
9.02	Record the "Operation data check sheet" during oil check operation.	Follow the oil check operation shown in the installation manual. "11 Operation / 11.1 Oil check verification".		
10. Test run (Oil return operation)				
10.01	Did you execute the oil return control?	Check the setting related to oil return control of the module controller. SH Guard ALC_r20:2.0K SH Start ALC_r21:4.0K Oil ALC setpoint LBP_r22:-2.0K Oil ALC setpoint MBP_r26:0.0K Oil ALC setpoint HBP_r27:3.0K EEV force low OD after oil recovery_r25:1min		
10.02	Does the oil return control start when the external input "CNS3" is connected?	Yes/No		
10.03	Did you write down the "Operation data check sheet" during oil return control.	Did the EEV opening surely expand during oil return control? Did the oil return control status change?		
11. Operation check of alarm				
11.01	Disconnect the sensor to confirm if the alarm is working.	Follow the oil check operation shown in the installation manual. "11 Operation / 11.1 Oil check verification".		

Instructions

Regular inspection check sheet

This table shows points of regular inspection to use safely the refrigerating equipment which uses highly pressurized CO₂ refrigerant. Inspect the machine regularly and, if any anomaly is discovered, repair it immediately, particularly when corrosion generates widely over the surface of compressor, or vessels, and deteriorates their strength. Inspect the Optyma iCO₂ at installation after regular intervals. Record the inspection results on the regular inspection check sheet.

Installation ID	
Installation Date	
Remarks	

Method	Inspection item	Inspection at installation(1)	Inspection at installation(2)	Inspection at installation(3)
Visual inspection	Does abnormal vibration, noise occur?			
	Does oil spread around or inside?			
	Are there traces of running rusty water around or inside?			
	Is the drain pan discharge outlet clogged?			
	Is rust observed on the surface of compressor?			
	Is rust observed on the surface of vessels?			
	Are insulation materials deteriorated, broken?			
	•Piping (Aeroflex)			
	•Compressor (felt, Aeroflex)			
	•Accumulator (Aeroflex)			
	•Receiver (Aeroflex)			
	Is the heat exchanger damaged?			
	Is the heat exchanger corroded?			
	Does oil spreads on the heat exchanger?			
	Is piping in the machine corroded?			
	Is piping in the machine rubbed?			
	Does oil spread at pipe joints on the compressor?			
	Are compressor terminals deteriorating?			
	Is the compressor casing rusty, corroded?			
	Does oil spread at expansion valve joints?			
	Are service ports capped?			
	Does oil spread at service ports?			
	Does oil spread at brazed sections?			
Is it frosting?				
Is the indicator hardware corroded?				
Are resin bands tightened properly?				
Are resin bands cracked?				
Operation inspection	Does abnormal noise or vibration (chatter) occur on the compressor or fan motor?			
	Does flash-gas generate at the liquid outlet?			
	Isn't refrigerant overcharged? (Does the high pressure error (7 segment display, E40) or liquid back from the medium pressure receiver (7 segment display, E43) occur?)			
	Is the oil level maintained above the lower limit during operation? (Check with 7 segment display, C32: Level switch.)			
	Does oil spread around or inside?			
	Is the movement control pressure suitable to the purpose of low pressure devices (load side)?			
	Is the cooling capacity of low pressure devices (load side) correct? (Turn off the thermostat.)			
	Is it normal the frequency of compressor start/stop? (10 times/h)			
	Is the suction gas superheating degree correct? (7 segment display, C49: Suction superheating degree 1, [Judgment guide] 1. It is not frosting at the compressor side from its suction inlet. 2. $5 \text{ deg} \leq \text{TsSH} \leq 40 \text{ deg}$			
	Is the discharge gas temperature correct? (7 segment display C08: Discharge pipe temperature (CM1), [Judgment guide] Td 125°C or under			
Is the waste heat short-circuited? (7 segment display C02: Outdoor air temperature (Tho-A))				



Danfoss A/S

Climate Solutions • danfoss.com • +45 7488 2222

Any information, including, but not limited to information on selection of product, its application or use, product design, weight, dimensions, capacity or any other technical data in product manuals, catalogues descriptions, advertisements, etc. and whether made available in writing, orally, electronically, online or via download, shall be considered informative, and is only binding if and to the extent, explicit reference is made in a quotation or order confirmation. Danfoss cannot accept any responsibility for possible errors in catalogues, brochures, videos and other material. Danfoss reserves the right to alter its products without notice. This also applies to products ordered but not delivered provided that such alterations can be made without changes to form, fit or function of the product.

All trademarks in this material are property of Danfoss A/S or Danfoss group companies. Danfoss and the Danfoss logo are trademarks of Danfoss A/S. All rights reserved.
