



iC7-Aqua and HVACR ULH Frequency Converters

Ultra Low Harmonic, FA10b/FB10b/FK10b (147–302 A)



1 Installation

1.1 Safety and Installation Awareness

An installation guide and a safety guide are provided with the drive. Before installing the drive, read all safety guidelines and precautions in the safety guide (BH319740379644). For details on cybersecurity, see *Security Features* in the *iC7 Series HVACR Application Guide* (AB528130368657) or the *iC7 Series Aqua Application Guide* (AB493837940842). More documentation – including a design guide and application guide – can be accessed by scanning the QR code on the front cover.

1.2 Required Tools

- Lifting aid
- Measuring tape
- Wrench with extensions and 8, 13, 17, 19 mm sockets
- Torx and slotted screwdrivers (T20, T25, SL1, and SL2)
- Wire crimper
- Sheet metal punch and/or pliers for cable entry plate

1.3 Verifying the Shipment and Its Contents

Make sure that the items supplied and the information on the product label correspond to the order confirmation. The product label is placed on the lower right corner of the exterior door and also on the interior of the drive. Use a Data Matrix ECC 200 compatible barcode reader to obtain the model code, code number, serial number, and manufacture date from the 2D code on the product label.

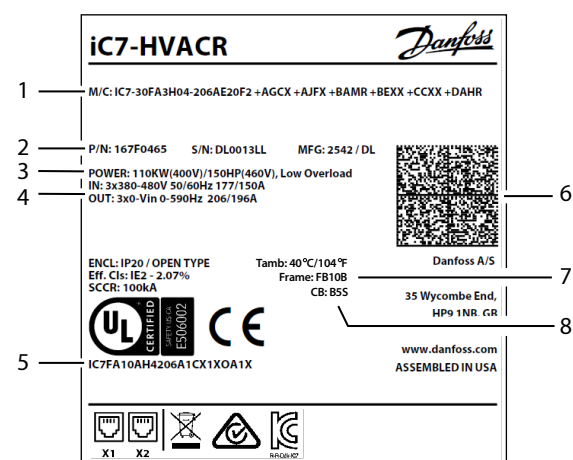

e30b1471.13

Figure 1: Example of a Product Label for the FA10b Drive

1	Model code	2	Code number, serial number, manufacture date (YYWW)
3	Power rating	4	Input and output voltage, frequency, and current
5	Compliance code	6	2D code
7	Frame designation	8	Control board designation

1.4 EMC-compliant Installation

For EMC-compliant installation, refer to the operating or design guide and follow the electrical installation instructions.

- Use shielded cables for motor (unshielded cables in metal conduit are acceptable) and control wiring.

- Connect the shield to the enclosures at both ends. If the shield connection points have a voltage potential difference, connect a low-impedance equalizing wire parallel to the shielded cable. Otherwise, break the shield connection on 1 end to avoid ground current loops.
- Ensure that motor cables are as short as possible to reduce the interference level from the entire system.
- Provide a minimum 200 mm (7.9 in) separation between mains input, motor cables, and control cables.
- Convey the currents from the motor cable shield back to the unit using an EMC plate with cable clamps or cable glands. Ensure good electrical contact from the mounting plate through the mounting screws to the drive chassis.

NOTICE

EMC EMISSION LIMITS

This drive may affect radio reception and does not comply with the emission limits for category C1. With the RFI filter disconnected, the drive meets category C4, but not category C2 limits.

- Do not use in residential locations.
- Contact Danfoss for assistance with C4 compliance.

1.5 Installing the Drive

Installation location is important. Full output current is available when the following installation conditions are met. For temperatures and altitudes outside this range, consult the *Derating* section in the design guide.

- For low overload, maximum ambient air temperature: 40 °C (104 °F) average over 24 hrs and 45 °C (113 °F) for 1 hr.
- Minimum ambient air temperature: -30 °C (-22 °F).
- Altitude < 1000 m (3280 ft) above sea level.
 1. Identify the frame and control board designations. See Illustration 1.
 2. Make sure that the operating environment and electrical installation meet the following standards.
 - a. Indoor unconditioned/pollution degree 2.
 - b. Overvoltage category 3.
 3. Review the wiring diagram based on the control board designation. See step 1 in the *Illustrations* section.

All wiring must comply with local and national regulations regarding cross-section and ambient temperature requirements. Loose connections can cause equipment faults or reduced performance. Tighten the terminals according to the proper torque value shown step 9 in the *Illustrations* section.

4. Review the fuse specifications. See step 2 in the *Illustrations* section.

This product is suitable for use on a circuit capable of delivering up to 100 kA short-circuit current rating (SCCR) at the respective drive voltage rating. For details, see the product label. For the short-circuit current rating for variants with built-in disconnect or circuit breaker/combination motor controller, see the design guide. For IEC installations with semiconductor fuses, use suitable branch circuit protection according to local regulations.

5. Review the power cable specifications. See step 3 in the *Illustrations* section.

Use copper wire with a minimum 70 °C (158 °F) rating. For aluminum wire, see the design guide.

6. Install the drive following the numbered steps in the *Illustrations* section. Certain illustrations/steps pertain to specific frame designations and are marked as such.
 - a. Remove or open the front panel/door using a T25 driver.
 - b. Attach the components from the accessory bag to the drive (step 4).

- c. Mount the drive on or against a solid, non-combustible mounting surface such as concrete or metal (step 5).
- d. Ensure proper cooling by providing necessary clearance around the drive. Wall-mount installations require 225 mm (8.9 in) top and bottom clearance, while floor-mount installations require 225 mm (8.9 in) top clearance only.
- e. Create the openings in the cable entry plate (step 6).
- f. Identify the terminals for functional extensions, fieldbus, power, and ground connections (step 7).

The DC+/DC- openings are for service only. Do not use them for load sharing.

- g. Install the motor, mains, and PE ground wiring (step 8).

For the FB10b/FK10b enclosures, remove the shaded panel to access the terminals. Reinstall and securely fasten the panel to the drive using a T20 driver. Torque the fasteners to 1.1 Nm (10 in-lb).

- h. Install the control wiring (step 9).
 - i. Route the control cables to the left side of the enclosure using the cable clips.
7. Securely fasten the cover(s) to the drive using a T25 driver. Torque the fasteners to 2.3 Nm (20 in-lb).
 8. Perform initial drive and motor setup. Consult the *iC7 Series Aqua Application Guide* or the *iC7 HVACR Application Guide*.
 9. Configure the fieldbus. Consult the appropriate iC7 fieldbus operating guide.

1.6 Functional Safety (Safe Torque Off)

The drive is shipped with all safe inputs de-energized. Without extra wiring to the safe I/O terminal blocks (X31 and X32), the STO function is always active and the motor will not turn. For more information, refer to the *iC7-Aqua and iC7-HVACR Functional Safety Operating Guide* (136R0448).

- To disable the STO function, install jumper wires to terminals X31 and X32. See step 9 in the *Illustrations* section.
- To use the STO function, wire a safety device to 1 or both of the safe I/O terminal blocks. See step 1 in the *Illustrations* section. To prevent erroneous faults or warnings from occurring, any unused safe I/O terminal blocks must be disabled using jumper wires or a jumper clip. One jumper clip is included in the accessory bag.

WARNING

RESIDUAL ROTATION

The STO function can be used for any type of motors. 2 faults can occur in the power semiconductor of the drive. A residual rotation can result from the faults. The rotation can be calculated to angle = $360/(\text{number of pole pairs})$.

- Ensure that this residual rotation does not pose a safety risk. The situation is not relevant for induction motors.

NOTICE

A successful commissioning test of the STO function is required after the initial installation and after each subsequent change to the installation or application involving the STO.

Commissioning test

There are 2 types of commissioning tests based on whether the STO parameter is configured for manual restart (M) or automatic restart (A). For more information on the STO parameter, see the application guide.

- If *Parameter 7.3.1 Safe Torque Off Response = Fault - reset required*, perform the steps marked with an "M".
- If *Parameter 7.3.1 Safe Torque Off Response = Warning - no reset required*, perform the steps marked with an "A".

Table 1: Commissioning Test for STO Functionality

Type of test	Commissioning steps	X
M/A	Power on the frequency converter.	
M/A	Verify that no safety faults are present.	
M/A	Start the motor.	
M/A	Without interrupting the mains supply, remove the 24 V DC voltage supply to both STO input terminals using the safety device.	
M/A	Verify that the motor coasts. This process can take some time.	
M/A	Verify that STO activated is shown on the control panel or in the event log.	
M/A	If the STO feedback is used, verify that STO is activated by checking the state of the STO Feedback.	
M/A	Reapply 24 V DC supply to both the STO input terminals.	
M/-	Verify that the motor remains in the coasted state and any connected relays remain activated.	
M/-	Send a reset signal via fieldbus, digital I/O, or the control panel.	
M/A	Verify that the motor starts up and runs within the original speed range.	

1.7 Power Losses and Efficiency

For power loss data including part load losses, see <https://energy.mydrive.danfoss.com>.

Illustrations

1

e30bn481.10

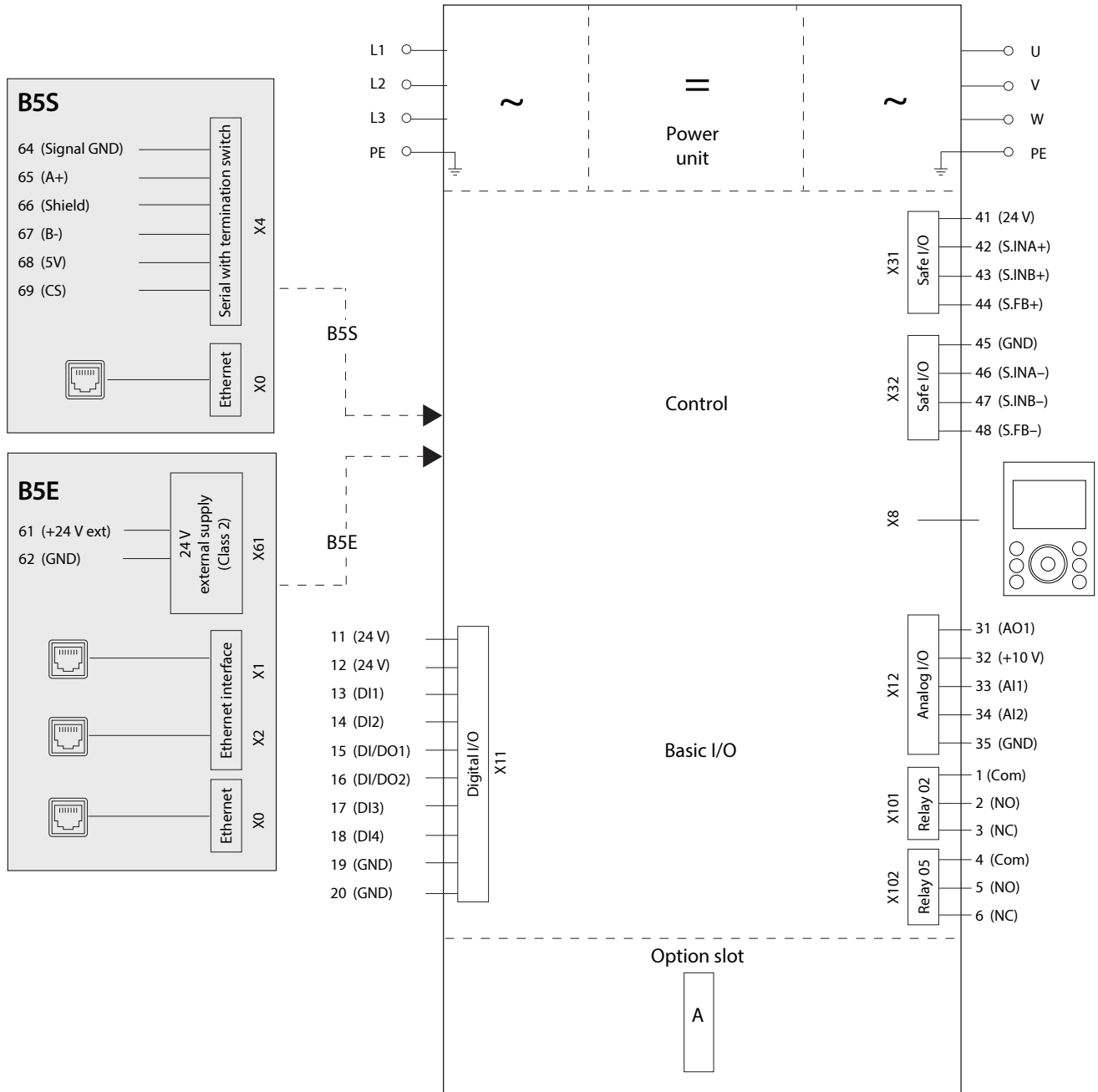

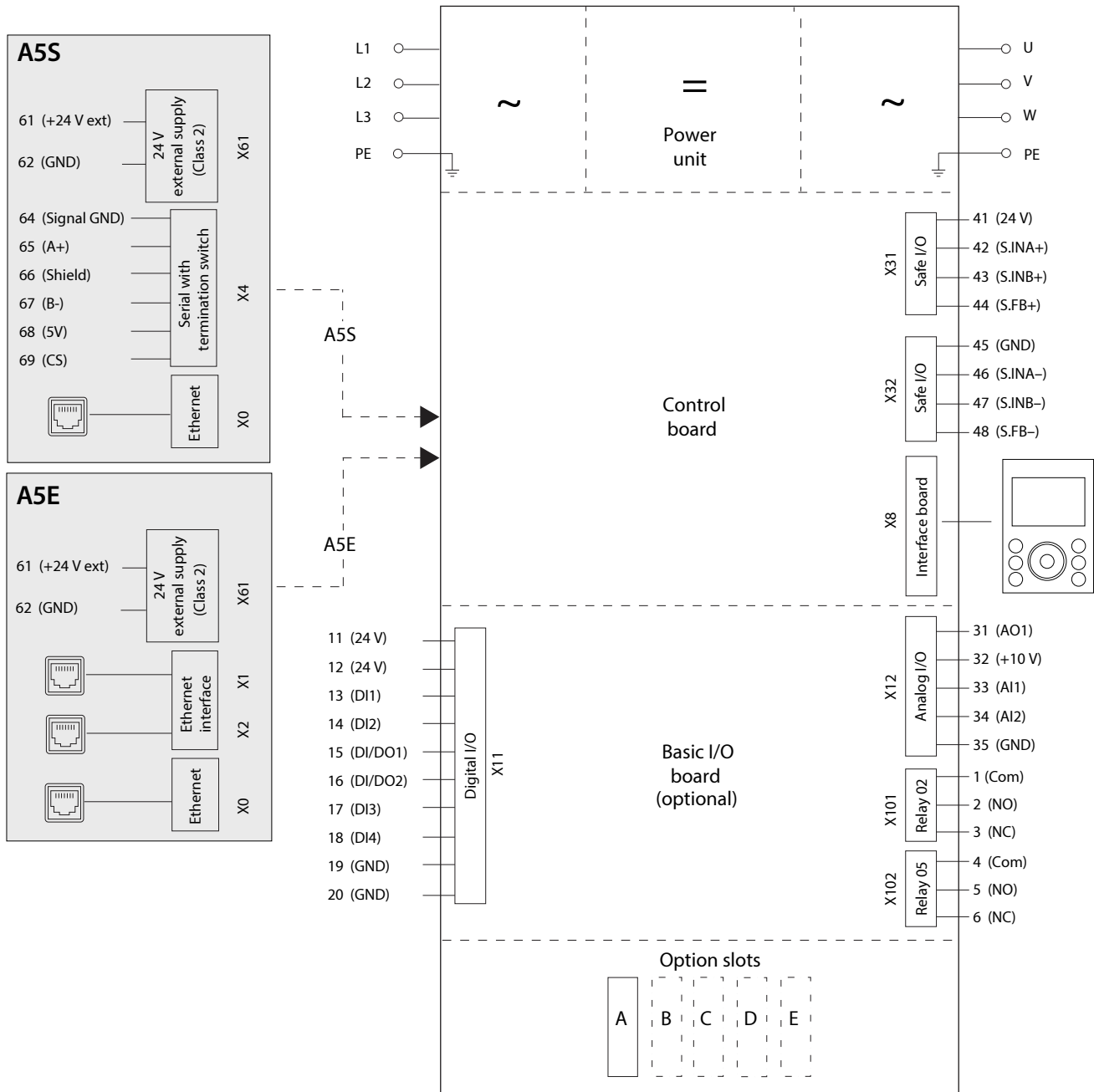

2

		 Bussmann P/N	
04-147A	FA10b	250 A, aR	170M1321
04-170A	FA10b	315 A, aR	170M2619
04-206A	FA10b	315 A, aR	170M2619
04-245A	FA10b	350 A, aR	170M2620
04-302A	FA10b	400 A, aR	170M2621

		 Bussmann P/N	
04-147A	FB10b/FK10b	250 A, aR	170M1321
04-170A	FB10b/FK10b	315 A, aR	170M2619
04-206A	FB10b/FK10b	315 A, aR	170M2619
04-245A	FB10b/FK10b	350 A, aR	170M2620
04-302A	FB10b/FK10b	400 A, aR	170M2621

e-30bl473.12

3

		L1/L2/L3 U/V/W [mm ² (AWG)]
04-147A	FA10b/FB10b/FK10b	50–150 (1–300 mcm)
04-170A	FA10b/FB10b/FK10b	2x120 (2x4/0), 3x70 (3x2/0)
04-206A	FA10b/FB10b/FK10b	2x120 (2x4/0), 3x70 (3x2/0)
04-245A	FA10b/FB10b/FK10b	2x120 (2x4/0), 3x70 (3x2/0)
04-302A	FA10b/FB10b/FK10b	2x120 (2x4/0), 3x70 (3x2/0)

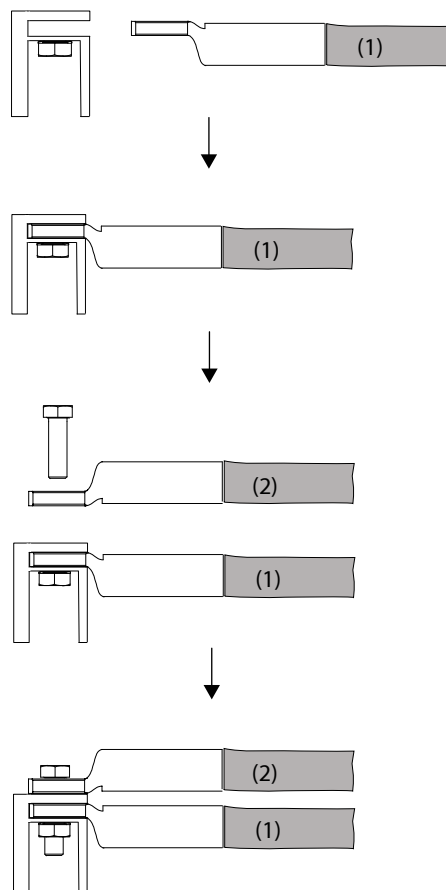

4 FA10b

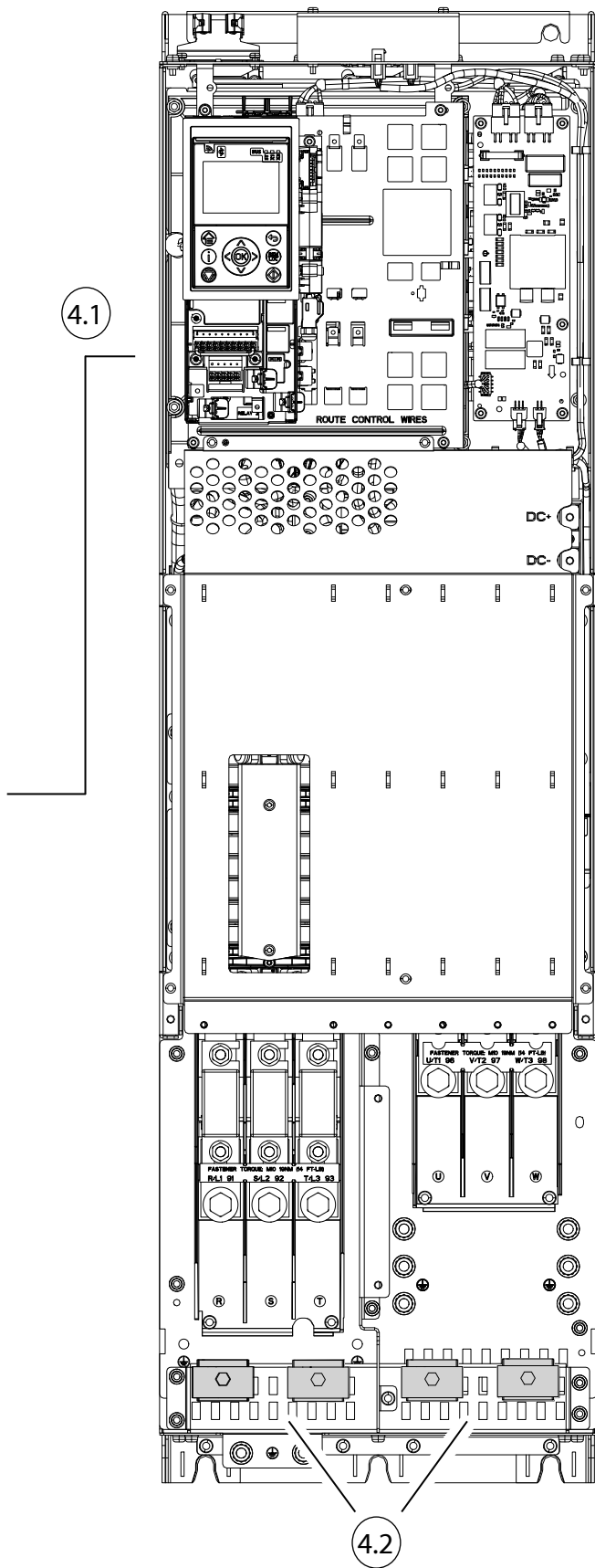
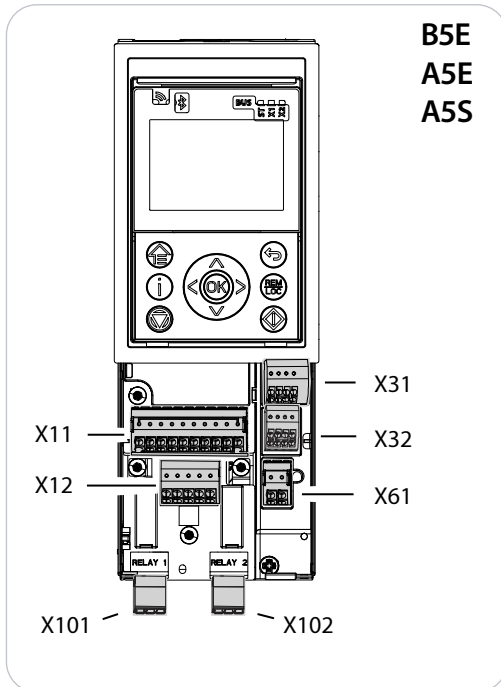
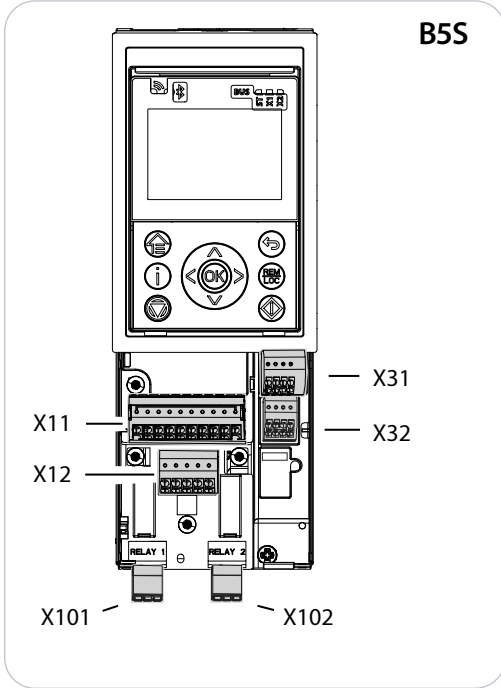

e30bl474.12

FB10b/FK10b

e30bn285.1.1

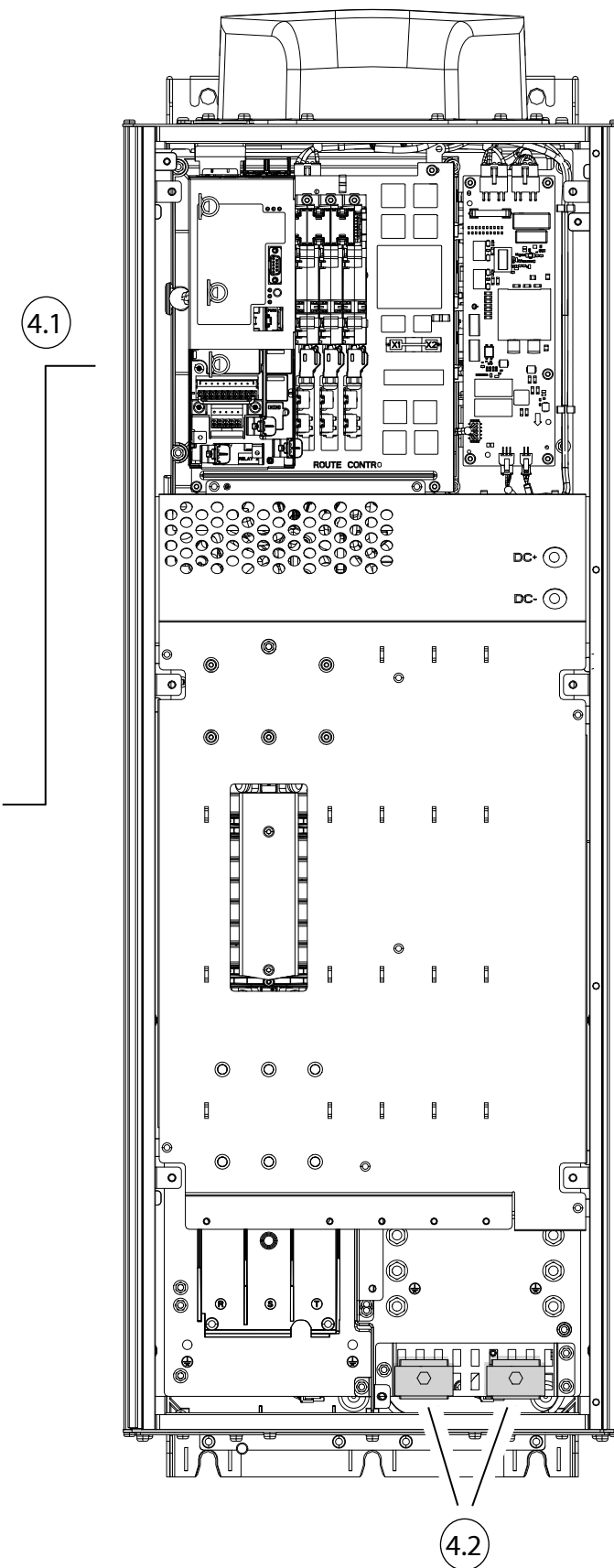
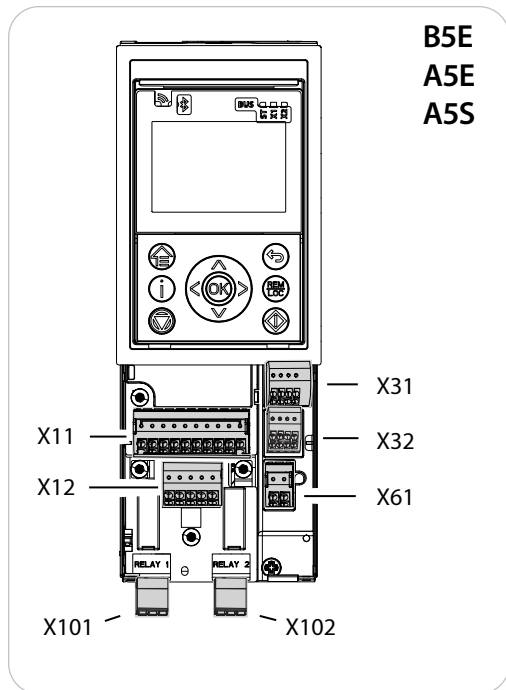
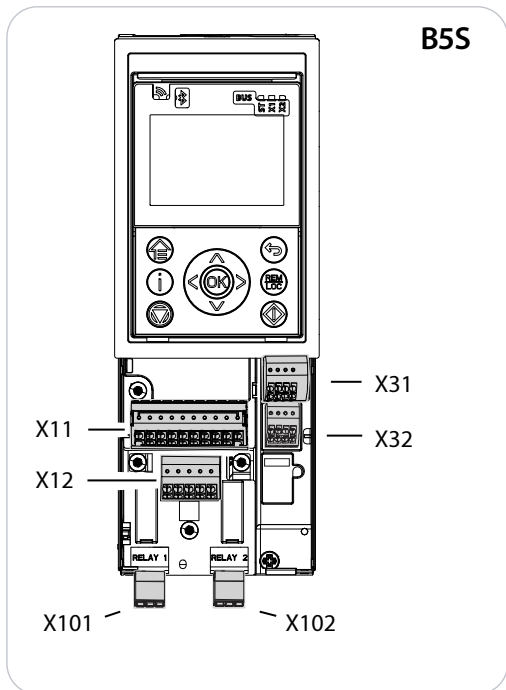

5

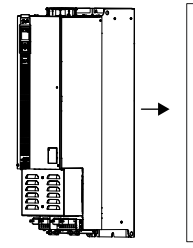

e30b(476.12

[mm (in)]	A	A1	B	B1	C	
FA10b	1150 (45.3)	15 (0.6)	174 (6.9)	35 (1.4)	225 (8.9)	6x M10
FB10b/FK10b	1150 (45.3)	15 (0.6)	174 (6.9)	35 (1.4)	225 (8.9)	6x M10

5.1

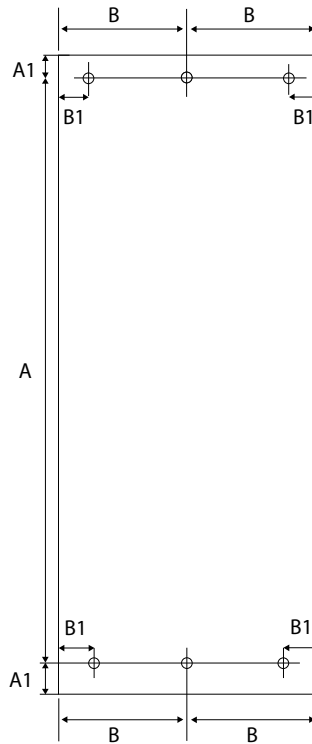

5.2

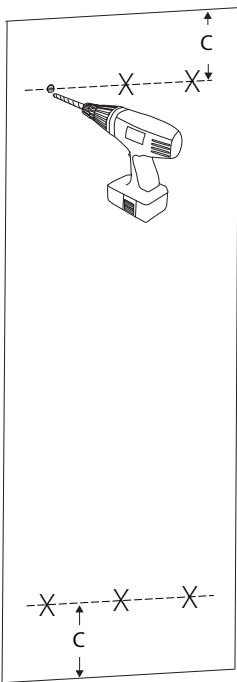

5.3



5.4

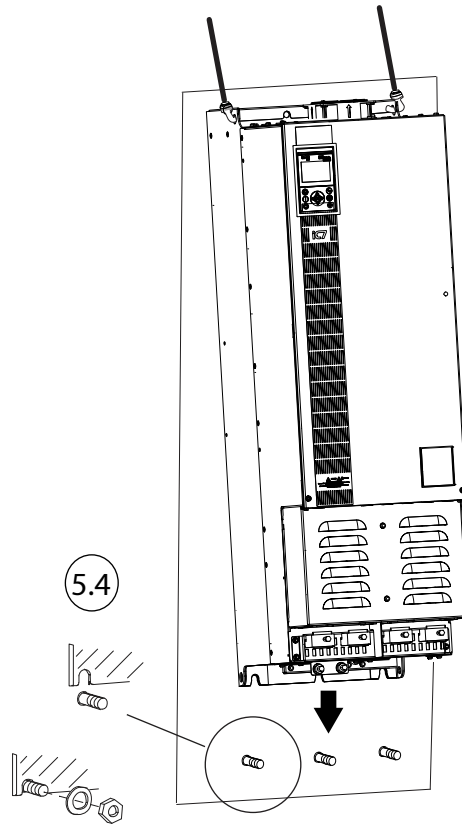

e30b1575.11

5.5

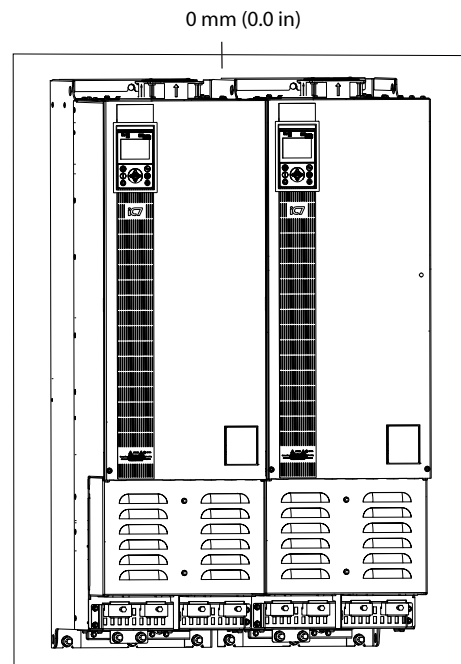
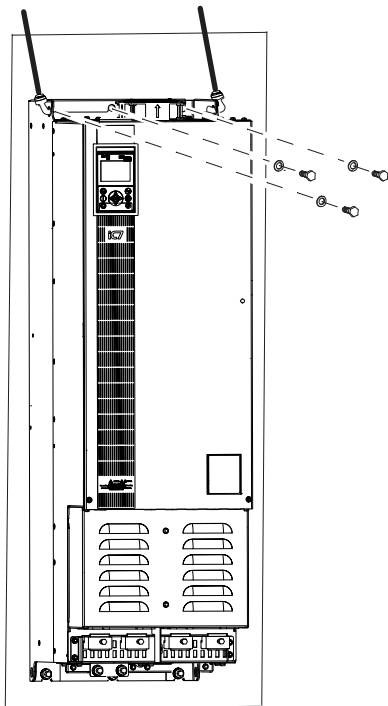

6

FA10b

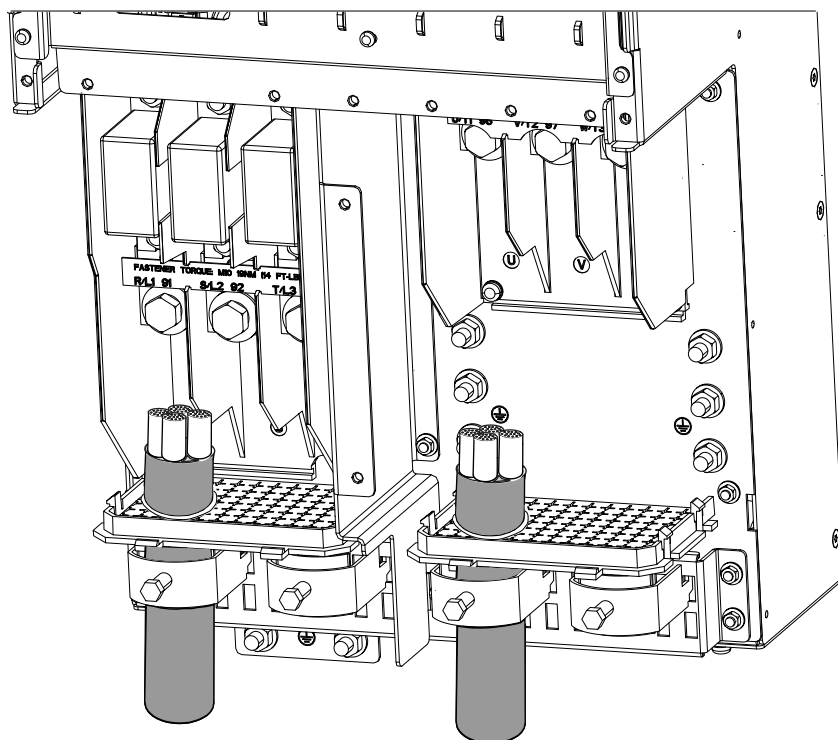

e30bl477.10

FB10b/FK10b

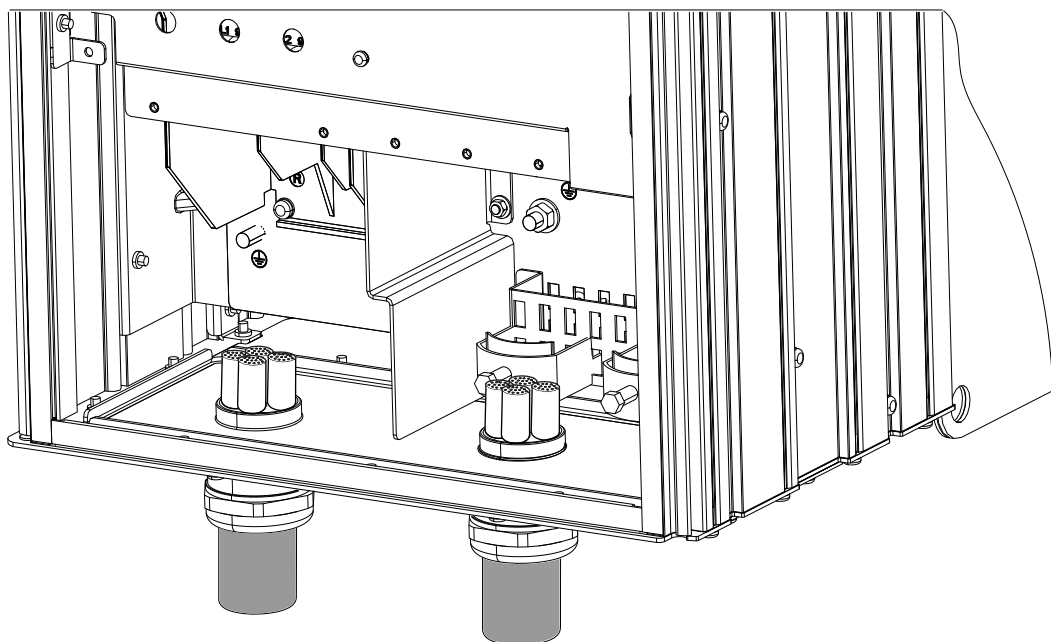

7 FA10b

e30b1478.12

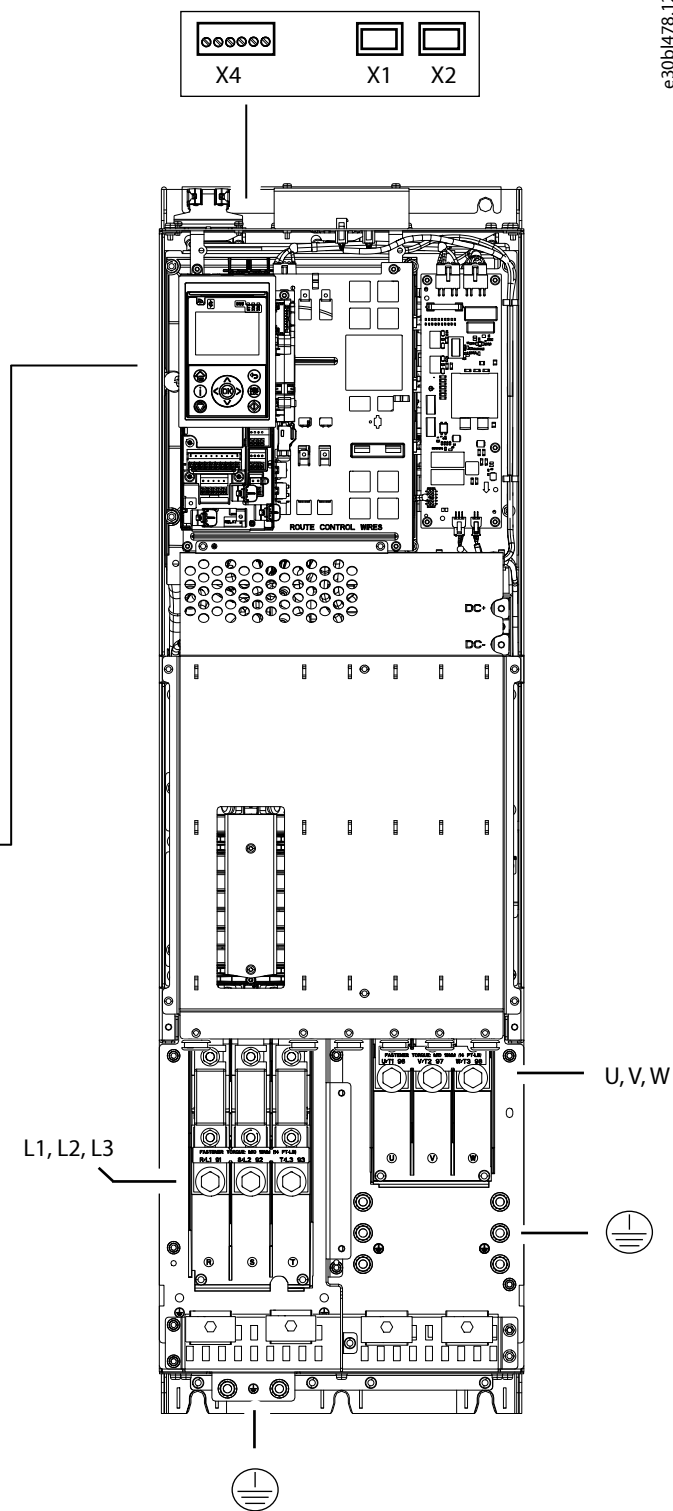
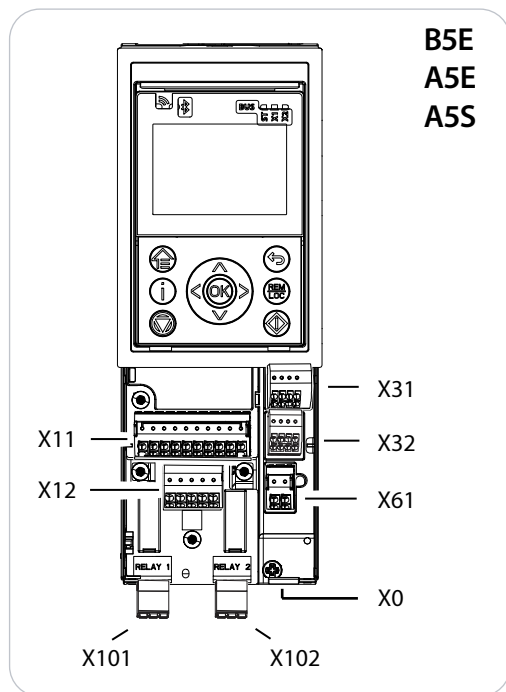
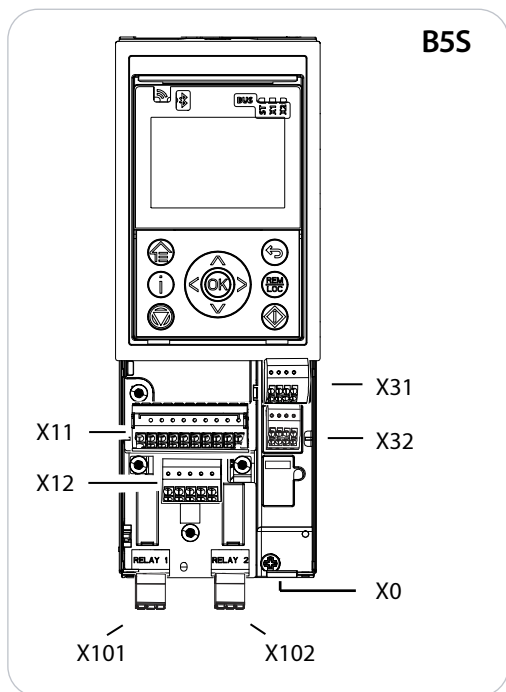

FB10b/FK10b

e30bn286.10

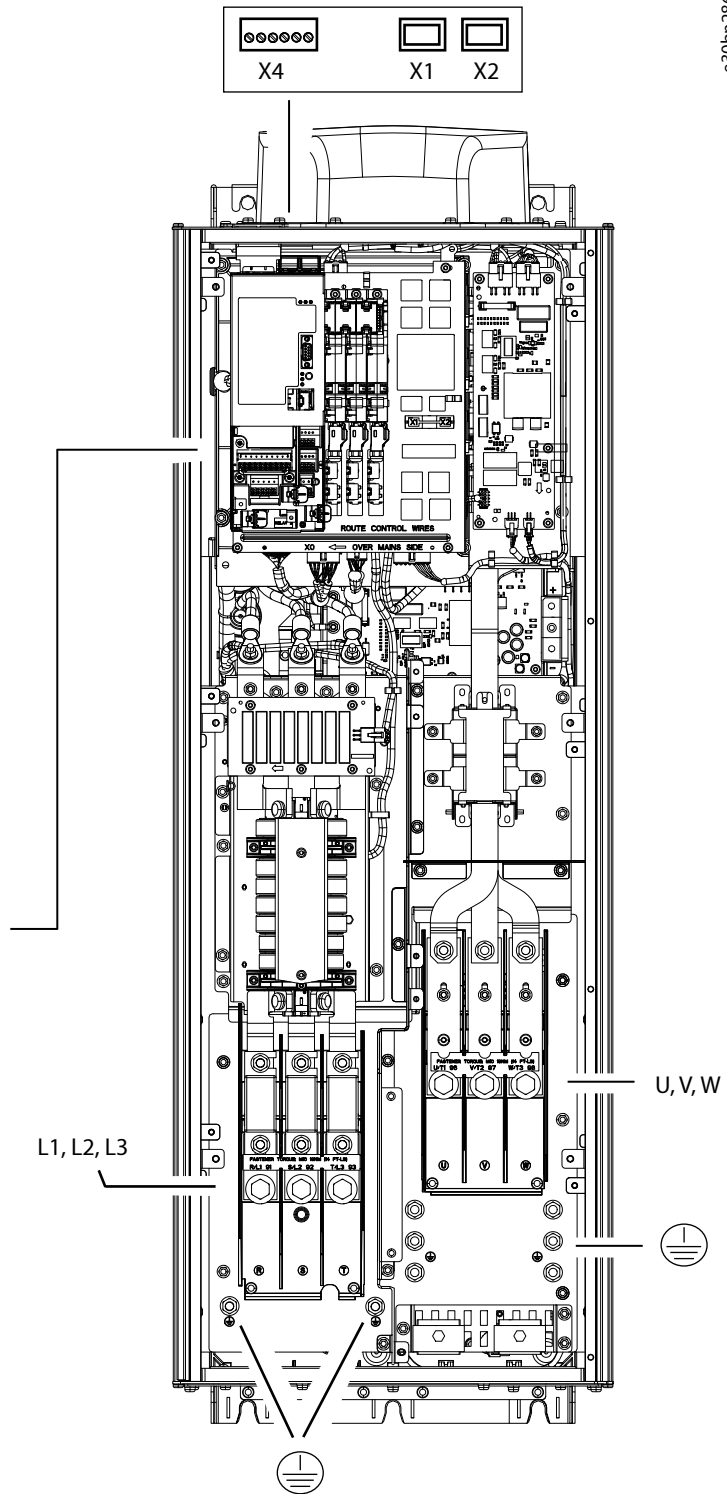
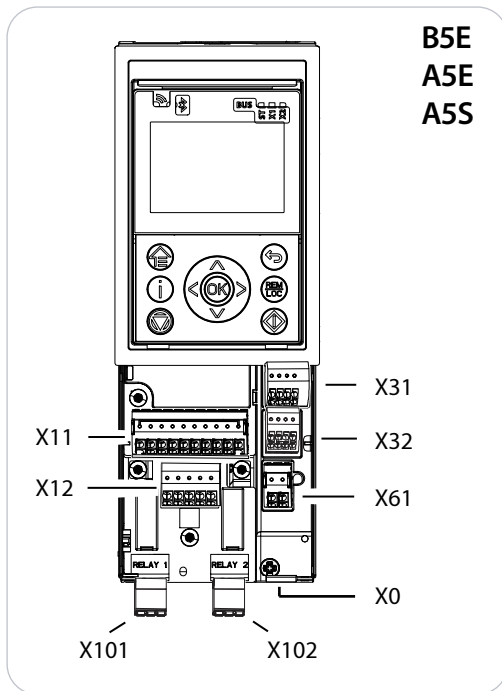
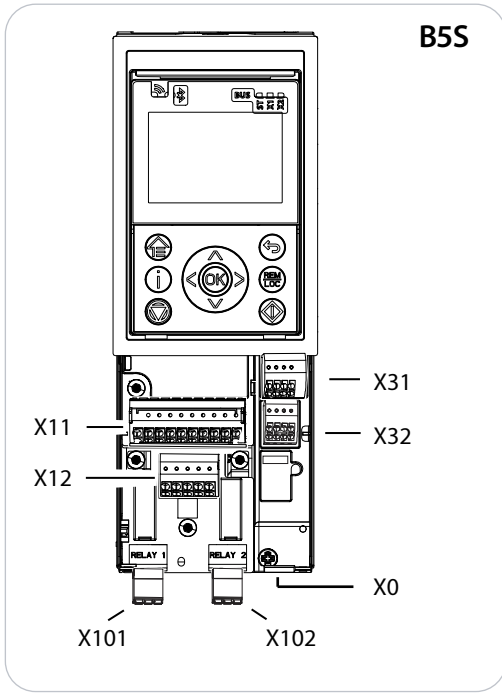

8 FA10b

e30bl481.11

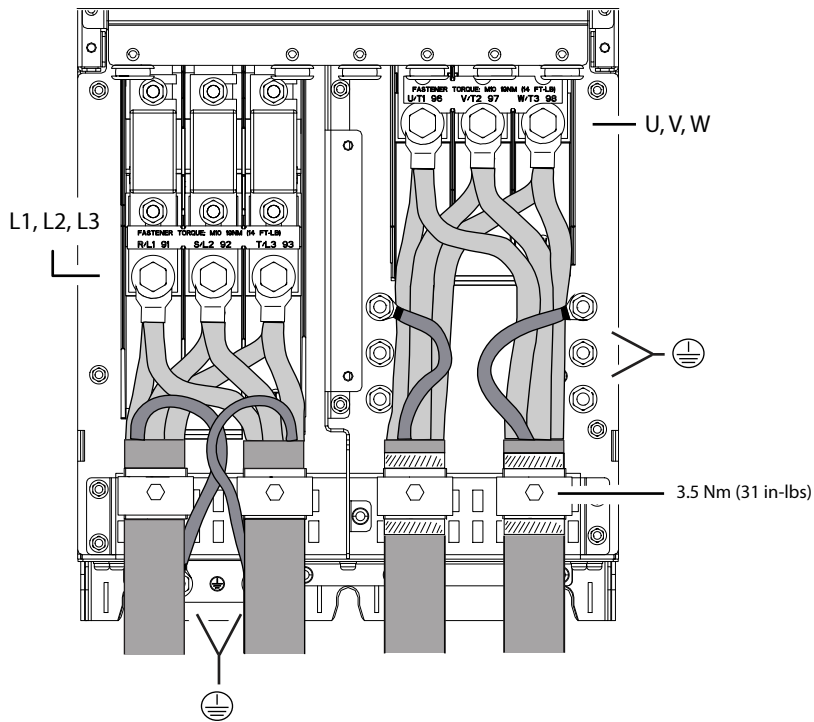

FA10b	L1, L2, L3		M10 [19 Nm (168 in-lb)]
	U, V, W		M10 [19 Nm (168 in-lb)]
			M8 [9,6 Nm (84 in-lb)]

FB10b/FK10b

e30bn287.11

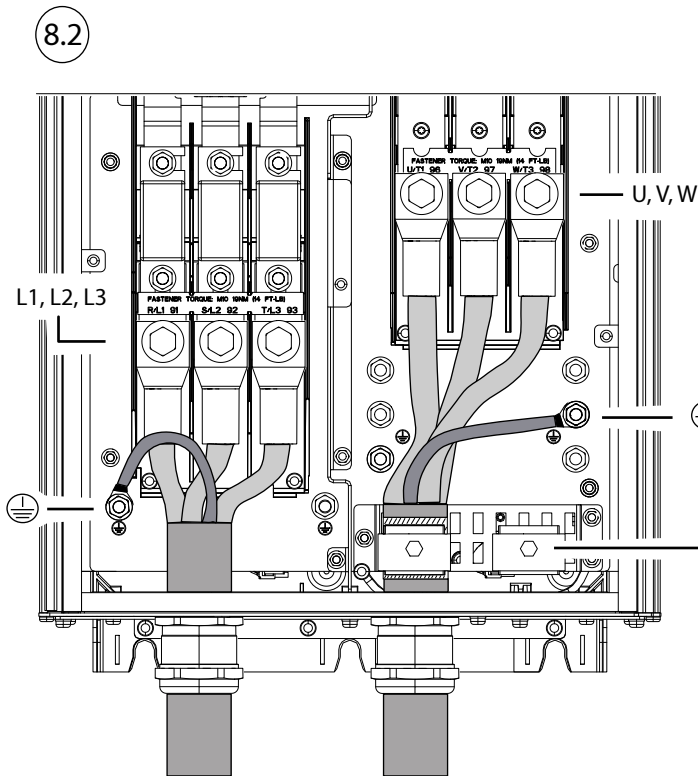
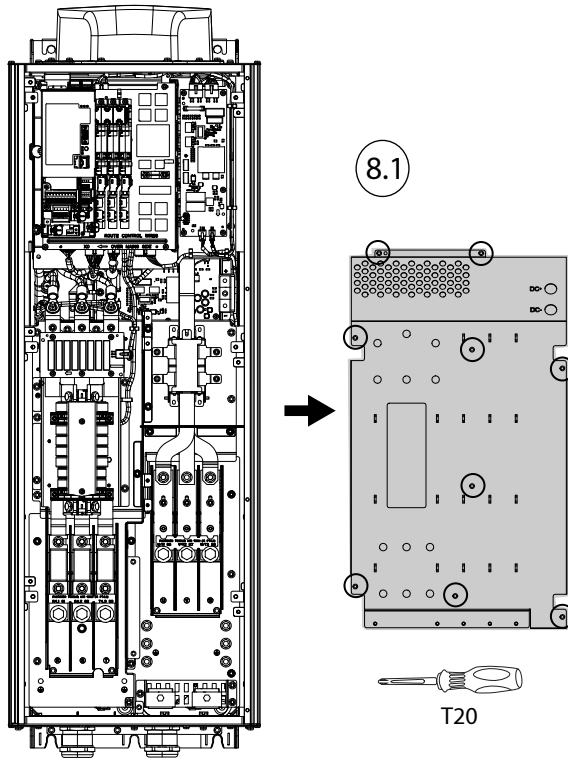

FB10b FK10b	L1, L2, L3		M10 [19 Nm (168 in-lb)]
	U, V, W		M10 [19 Nm (168 in-lb)]
			M8 [9.6 Nm (84 in-lb)]

9

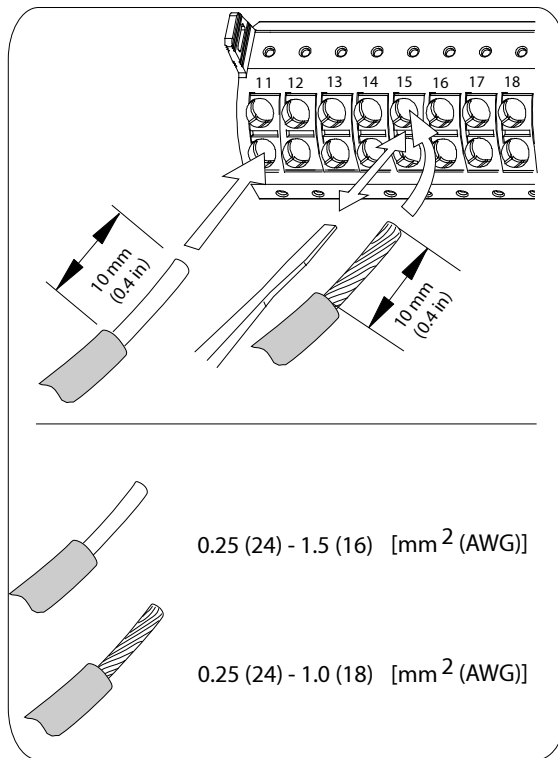
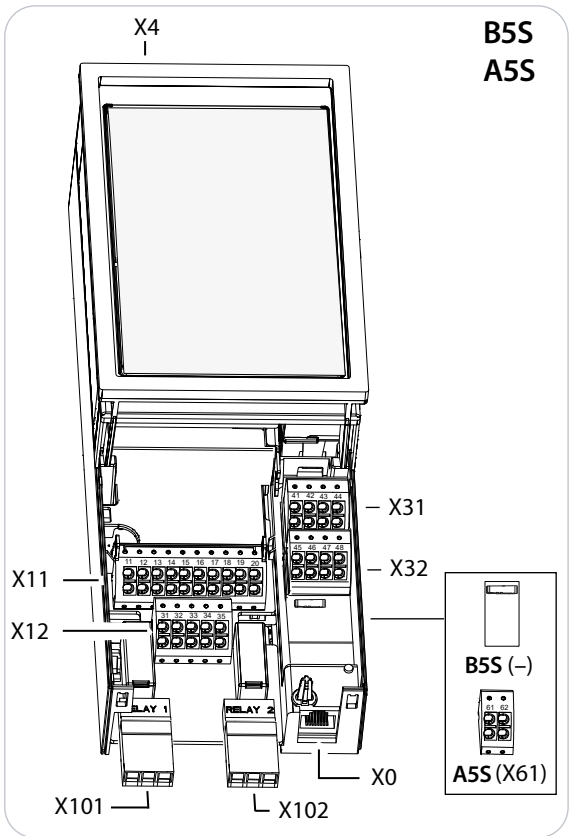
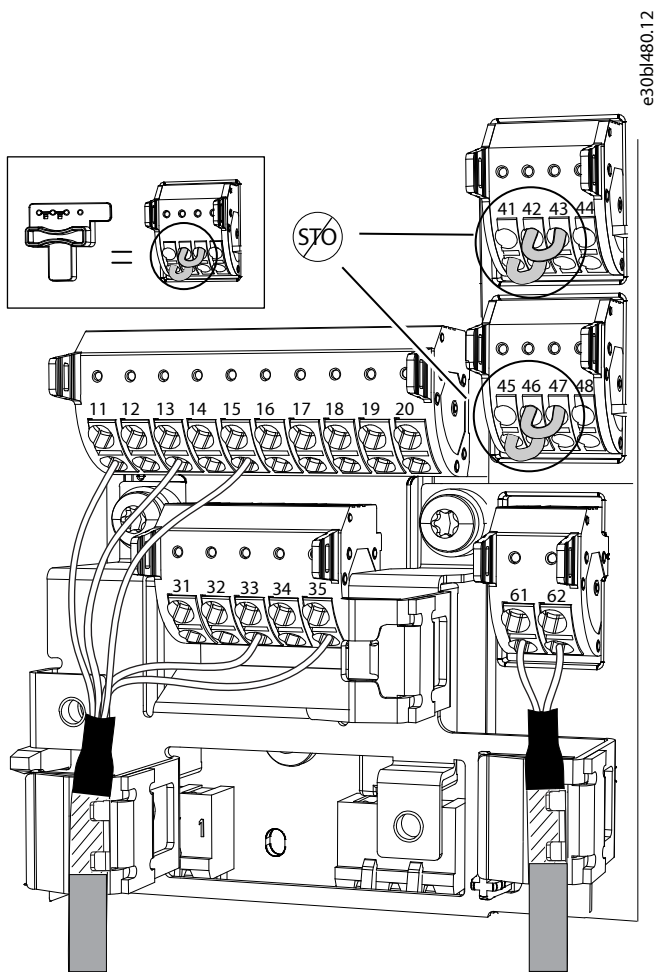
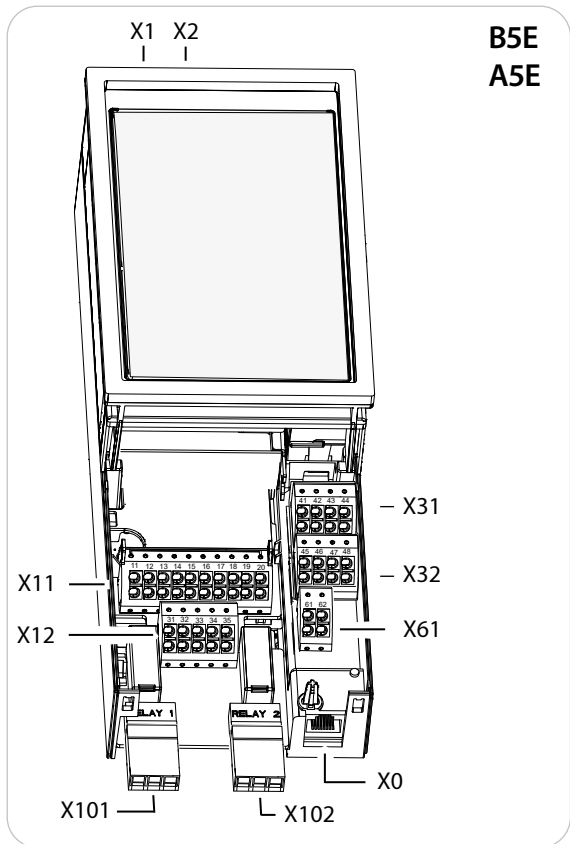



Danfoss A/S
 6430 Nordhøj
 Denmark
 CVR no.: 20 16 57 15
 Telephone: +45 7489 2222
 www.danfoss.com

EU DECLARATION OF CONFORMITY

Danfoss A/S Danfoss Drives

declares under our sole responsibility that the

Product category: Frequency Converter, **IC7-Aqua**
Type designation(s): IC7YYYYYYYYYYYYYY**YY

are varying numbers or letters indicating drive configurations which impact this Doc.

Character 4-5 (Frame type)	FA, FB, FK
Character 6-7 (Frame size)	02, 04, 05, 06, 07, 08, 09, 10, 11, 12
Character 8 (Cooling type)	A
Character 9-10 (Voltage class)	H4, T4
Character 11-14 (Current rating)	01A3, 01A8, 02M4, 03A0, 04A0, 05A6, 07A2, 09A2, 12A5, 16A0, 24A0, 31A0, 38A0, 43A0, 61A0, 73A0, 90A0, 106A, 147A, 170A, 206A, 245A, 302A, 385A, 395A, 480A, 588A, 658A, 736A, 799A, 893A, 1000, 1120, 1260
Character 15 (Enclosure rating)	1, 2, 4, 5, A, B
Character 16 (RRF class)	B, C, D, E
Character 17 (Brake)	X, 1
Character 18 (Internal fuse)	X, 1, 2, 3
Character 19 (DC-terminals)	X, 1
Character 23 (Functional Safety)	X

* may be any number or letter indicating drive options which do not impact this Doc.

Covered by this declaration is in conformity with the following directive(s), standard(s) or other normative document(s), provided that the product is used in accordance with our instructions.

- Low Voltage Directive 2014/35/EU**
- EN 61800-5-1:2007+A1:2017+A11:2021 Adjustable speed electrical power drive systems – Part 5-1: Safety requirements – Electrical, thermal and energy.
- EN IEC 61800-5-1:2023* Adjustable speed electrical power drive systems – Part 5-1: Safety requirements – Electrical, thermal and energy.
* only for F807A14, P*10AH4 (* indicates A, B or K)

Date: 05 March 2026 Place of issue: Grasten, DK Signed by: Name: Henrik Lorenzen Title: Product Owner	Date: 05 March 2026 Place of issue: Grasten, DK Signed by: Name: Mari Haapala Title: Vice President
---	---

Danfoss only authorizes for the correctness of the English version of this declaration. In the event of the declaration being translated into any other language, the translation concerned shall be liable for the correctness of the translation.

ID No: 0078 336
Revision No: A6
The doc. is managed by 5008577



EMC Directive 2014/30/EU
 EN IEC 61800-3:2022

Adjustable speed electrical power drive systems – Part 3: EMC requirements and specific test methods.

RoHS Directive 2011/65/EU including amendment 2015/863.
 EN IEC 63000:2018

Technical documentation for the assessment of electrical and electronic products with respect to the restriction of hazardous substances.

Commission Regulation (EU) 2019/1781 under the Ecodesign Directive 2009/125/EC including amendment in Commission Regulation (EU) 2021/341
 EN IEC 61800-9-2:2025

Adjustable speed electrical power drive systems (PDS) - Part 9-2: Ecodesign for motor systems - Energy efficiency determination and classification.

Danfoss only authorizes for the correctness of the English version of this declaration. In the event of the declaration being translated into any other language, the translation concerned shall be liable for the correctness of the translation.

ID No: 0078 336
Revision No: A6
The doc. is managed by 5008577

21.750u0q3



Danfoss A/S
 6630 Nordborg
 Denmark
 CTR no.: 20 18 97 13
 Telephone: +45 7488 2222
 www.danfoss.com

EU DECLARATION OF CONFORMITY

Danfoss A/S
Danfoss Drives

declares under our sole responsibility that the

Product category: Frequency Converter, IC7-HVACR
Type designation(s): IC7YYYYYYYYYYYYYYYY**Y

Y are varying numbers or letters indicating drive configurations which impact this DoC.

- Character 4-5 (Frame type) FA, FK, FB
 - Character 6-7 (Frame size) 02, 04, 05, 06, 07, 08, 09, 10, 11, 12
 - Character 8 (Cooling type) A
 - Character 9-10 (Voltage class) H4, T4
 - Character 11-14 (Current rating) 01A3, 01A8, 02A4, 03A0, 04A0, 05A6, 07A2, 09A2, 12A5, 16A0, 24A0, 31A0, 38A0, 42A0, 61A0, 73A0, 90A0, 106A, 147A, 170A, 206A, 245A, 302A, 385A, 395A, 480A, 588A, 658A, 736A, 799A, 895A, 1000, 1120, 1260
 - Character 15 (Enclosure rating) 1, 2, 4, 5, A, B
 - Character 16 (RRI class) B, C, D, E
 - Character 17 (Brake) X, 1
 - Character 18 (Internal fuse) X, 1, 2, 3
 - Character 19 (DCterminals) X, 1
 - Character 23 (Functional Safety) X, A
- * may be any number or letter indicating drive options which do not impact this DoC.

Covered by this declaration is in conformity with the following directive(s), standard(s) or other normative document(s), provided that the product is used in accordance with our instructions.

- Low Voltage Directive 2014/35/EU** EN 61800-5-1:2007+A1:2017+A11:2021 Adjustable speed electrical power drive systems – Part 5-1: Safety requirements – Electrical, thermal and energy.
- EN IEC 61800-5-1:2023* Adjustable speed electrical power drive systems – Part 5-1: Safety requirements – Electrical, thermal and energy.
* only for F807AH4, F810AH4/e indicates A, B or X)

Date: 5 March 2026 Place of issue: Graasten, DK	Signed by: Signature: Name: Arne Fink Hansen Title: Product Owner	Date: 5 March 2026 Place of issue: Graasten, DK	Signed by: Signature: Name: Mari Haapala Title: Vice President
--	--	--	---

Danfoss only vouches for the correctness of the English version of this declaration. In the event of the declaration being translated into any other language, the translator concerned shall be liable for the correctness of the translation.

ID No: 0083589
 The doc. is managed by: 50889577

Revision No: A.8

Page 1 of 2



Machinery Directive #2006/42/EU (only applicable for Character 23 equals A)
 EN 61800-5-2:2017 Adjustable speed electrical power drive systems - Part 5-2: Safety requirements - Functional

Character 23:
 X = no functionality
 A = ABECl

EMC Directive 2014/30/EU
 EN IEC 61800-3:2023 Adjustable speed electrical power drive systems – Part 3: EMC requirements and specific test methods.

RoHS Directive 2011/65/EU including amendment 2015/863.
 EN IEC 63000:2018 Technical documentation for the assessment of electrical and electronic products with respect to the restriction of hazardous substances.

Commission Regulation (EU) 2019/1781 under the Ecodesign Directive 2009/125/EC including amendment in Commission Regulation (EU) 2021/341
 EN IEC 61800-9-2:2025 Adjustable speed electrical power drive systems (PDS) - Part 9-2: Ecodesign for motor systems - Energy efficiency determination and classification

Batteries Regulation 2023/1542 concerning batteries and waste batteries, amending Directive 2008/98/EC and Regulation (EU) 2019/1020 and repealing Directive 2006/66/EC
 EN 45554:2020 General methods for the assessment of the ability to repair, reuse and upgrade energy-related products

Packaging and packaging waste Regulation 2025/40/EU
 Article 5 Requirements for substances in packaging

Danfoss only vouches for the correctness of the English version of this declaration. In the event of the declaration being translated into any other language, the translator concerned shall be liable for the correctness of the translation.

ID No: 0083589
 The doc. is managed by: 50889577

Revision No: A.8

Page 2 of 2



Danfoss A/S
Ulsnaes 1
DK-6300 Graasten

Any information, including, but not limited to information on selection of product, its application or use, product design, weight, dimensions, capacity or any other technical data in product manuals, catalog descriptions, advertisements, etc. and whether made available in writing, orally, electronically, online or via download, shall be considered informative, and is only binding if and to the extent, explicit reference is made in a quotation or order confirmation. Danfoss cannot accept any responsibility for possible errors in catalogs, brochures, videos and other material. Danfoss reserves the right to alter its products without notice. This also applies to products ordered but not delivered provided that such alterations can be made without changes to form, fit or function of the product. All trademarks in this material are property of Danfoss A/S or Danfoss group companies. Danfoss and the Danfoss logo are trademarks of Danfoss A/S. All rights reserved.

M00438
AN481260608003en-000501
Danfoss A/S © 2026.03

