



iC7-Aqua Frequency Converters

1.3–1260 A



Contents

1 Introduction

1.1 Purpose of this Design Guide	11
1.2 Intended Use	11
1.3 Additional Resources	11
1.4 Planning and Design Support Materials	12
1.4.1 Overview	12
1.4.2 Locating Support Information	12
1.5 Version History	12

2 Safety

2.1 Safety	14
2.2 Safety Symbols	14
2.3 Medical Devices	14
2.4 General Safety Considerations	15
2.5 Qualified Personnel	16

3 Approvals and Certifications

3.1 Product Approvals and Certifications	17
3.2 Standards	18
3.3 Export Control Regulation	18

4 Danfoss iC7 Series

4.1 Overview of iC7 Series	19
4.2 Ecodesign for Power Drive Systems	19
4.2.1 Overview	19
4.2.2 Power Losses and Efficiency	20

5 iC7 Frequency Converters

5.1 Overview	22
5.2 Drive Models and Frame Designations	22
5.3 Power Unit	22
5.4 Power Unit Options	24
5.5 Control Unit and Interfaces	24
5.6 Control Panels	26

5.7 Functional Safety	26
5.8 Overload Capability	26
5.8.1 Load Profile Overview	26
5.8.2 Low Overload (LO)	27
5.8.3 High Overload (HO1)	27
6 iC7-Aqua Application Software	
6.1 Basic Functions	28
6.2 Controllers	29
6.3 Water, Wastewater, and Irrigation Features	29
6.4 Motor Control Features	30
6.5 Protection Features	31
6.6 Monitoring, Logging, and History Log	32
6.7 Security Features	33
6.8 Software Tools	33
7 Options and Accessories	
7.1 Overview of Options and Accessories	35
7.2 Fieldbus Options	35
7.3 Functional Extension Options	35
7.4 Input and Output Filters	38
7.4.1 Sine-wave Filters	38
7.4.2 dU/dt Filters	38
7.4.3 Common-mode Filters	38
7.4.4 Harmonic Filters	38
7.5 Kits and Accessories	39
7.5.1 Overview of Kits and Accessories	39
7.5.2 Back-channel Cooling Kits	39
7.5.3 Pedestal Kits	39
7.5.4 Control Panel Mounting Kits and Cables	39
7.5.5 Ground Bar Kits	40
7.5.6 Cable and Wire Installation Kits	40
8 Specifications	
8.1 Overview	41

8.2 Ratings	41
8.2.1 Overview	41
8.2.2 Ratings for Frequency Converters with 380–480 V Supply Voltage	41
8.2.3 6-pulse Frequency Converters	42
8.2.3.1 Current and Power Ratings 380–414 V AC	42
8.2.3.2 Current and Power Ratings 415–440 V AC	43
8.2.3.3 Current and Power Ratings 441–480 V AC	44
8.2.4 Ultra Low-Harmonic Frequency Converters	45
8.2.4.1 Current and Power Ratings 380–414 V AC	45
8.2.4.2 Current and Power Ratings 415–440 V AC	46
8.2.4.3 Current and Power Ratings 441–480 V AC	46
8.3 General Technical Data	47
8.3.1 Grid Side	47
8.3.2 Motor Output and Motor Data	47
8.3.3 Torque Characteristics	47
8.3.4 Control Characteristics	48
8.3.5 Control I/O	48
8.3.5.1 Overview	48
8.3.5.2 Analog Input	49
8.3.5.3 Analog Output	49
8.3.5.4 Digital and Pulse Input	50
8.3.5.5 Digital and Pulse Output	50
8.3.5.6 Relay Output	51
8.3.5.7 Auxiliary Voltages	51
8.3.6 Functional Safety	51
8.3.6.1 Functional Safety Standards and Performance	51
8.3.6.2 Technical Data	52
8.3.7 Real-time Clock	54
8.3.8 Ambient Conditions	54
8.3.8.1 Overview	54
8.3.8.2 Ambient Conditions during Transport	54
8.3.8.3 Ambient Conditions during Storage	55
8.3.8.4 Ambient Conditions during Operation	55
8.3.9 Discharge Times	56
8.4 Fuses and Circuit Breakers	56
8.4.1 Overview	56

8.4.2	6-pulse Frequency Converters	56
8.4.2.1	IEC Compliant Fuses	56
8.4.2.2	UL Compliant Fuses	58
8.4.2.3	IEC Compliant Circuit Breakers	61
8.4.2.4	UL Compliant Circuit Breakers and Combination Motor Controllers	62
8.4.3	Ultra Low-Harmonic Frequency Converters	63
8.4.3.1	IEC Compliant Fuses	63
8.4.3.2	UL Compliant Fuses	63
8.4.4	Protection of DC Interface	64
8.5	Dimensioning of Power Cables	64
8.6	Cooling and Power Loss	68
8.6.1	Power Losses	68
8.6.1.1	Overview	68
8.6.1.2	Power Loss, 6-pulse Frequency Converters	68
8.6.1.3	Power Loss, Ultra Low-harmonic Frequency Converters	69
8.6.2	Airflow and Noise Levels	70
8.7	Energy Efficiency Data	71
8.8	Packaging	72
8.9	Cable Length	74
8.10	EMC	75
8.10.1	EMC Compliance Levels	75
8.10.2	Emission Requirements	76
8.10.3	Immunity Requirements	77
9	Exterior and Terminal Dimensions	
9.1	Overview	78
9.2	IP20/UL Open Type Frames (FA02–FA12)	79
9.3	IP21/UL Type 1 Frames (FK03–FK12)	97
9.4	IP54/IP55/UL Type 12 Frames (FB03–FB12)	109
10	Mechanical Installation Considerations	
10.1	Contents of the Shipment	121
10.2	Product Labels	121
10.2.1	Overview	121
10.2.2	Product Labels on Drives	121
10.2.3	Package Labels	123

10.2.4	Product Labels on Functional Extensions	123
10.2.5	Product Labels on Control Panels	124
10.3	Disposal	125
10.3.1	Recommended Disposal	125
10.3.2	Real-time Clock Battery Disposal	125
10.4	Storage until Installation	125
10.4.1	Reforming the Capacitors	125
10.4.2	Safe Transportation and Storage	126
10.5	Prerequisites for Installation	127
10.5.1	Overview	127
10.5.2	Operating Environment	127
10.6	Derating for Operating Conditions	128
10.6.1	Overview	128
10.6.2	Derating for Ambient Temperature	128
10.6.3	Derating for Altitude	129
10.6.4	Derating for Output Frequency	131
10.6.5	Derating for Switching Frequency	131
10.7	Inspection and Maintenance Considerations	133
10.7.1	Overview	133
10.7.2	Regular Maintenance	134
10.7.3	Service Access	134
10.7.4	Heat Sink and Fan Maintenance and Service	134
10.7.5	Backup Battery Exchange	135
10.8	Mechanical Installation	135
10.8.1	Overview	135
10.8.2	Mounting Considerations	135
10.8.3	Mounting Locations	136
10.8.4	Mounting Orientation	138
10.8.5	Recommended Fasteners	139
10.8.6	Drilling Patterns	140
10.8.6.1	Overview	140
10.8.6.2	Drilling Patterns for Wall-mounted Frames (FA02–FA12)	140
10.8.6.3	Drilling Patterns for Wall-mounted Frames (FB03–FB12)	142
10.8.6.4	Drilling Patterns for Wall-mounted Frames (FK03–FK12)	142
10.8.6.5	Drilling Patterns for Free-standing Frames (FK10c/FB10c, FK11/FB11, FK12/FB12)	142
10.8.7	Placement of the Drive in the Installation	143

10.8.8 Cooling	144
10.8.8.1 Overview of Cooling	144
10.8.8.2 Forced Air Cooling	144
10.8.8.3 Back-channel Cooling	145
10.8.9 Recommended Space for Service Access	146

11 Electrical Installation Considerations

11.1 Wiring Diagram for the Standard Control Board (B5S, B5E)	148
11.2 Wiring Diagram for the Advanced Control Board (A5S, A5E)	149
11.3 Grid Type and Protection	150
11.3.1 Grid Types	150
11.3.2 Currents on Protective Earth and Potential Equalization/Leakage Currents	150
11.3.3 PE Current Measurement	150
11.3.4 Residual Current Device (RCD) Protection	152
11.3.5 Isolation Monitoring Devices	152
11.4 EMC-compliant Installation Guidelines	153
11.4.1 Overview	153
11.4.2 Power Cables and Grounding	155
11.4.3 Control Cables	157
11.5 Motor Installation Considerations	157
11.5.1 Overview	157
11.5.2 Supported Motor Types	157
11.5.3 Motor Insulation	158
11.5.4 Parallel Motors	158
11.5.5 Bearing Currents	158
11.5.6 Motor Thermal Protection	158
11.5.7 Electronic Thermal Relay Function	159
11.5.8 External Connected Sensors	159
11.6 Power Cable Considerations	159
11.6.1 Overview	159
11.6.2 Torque Requirements	160
11.7 Control Connections	161
11.7.1 Overview	161
11.7.2 Functional Safety I/Os (X31, X32)	163
11.7.3 External 24 V Supply (X61)	163
11.7.4 Digital and Analog I/O (X11/X12)	163

11.7.5 Relay (X101/X102)	164
11.7.6 Communication Ports (X0, X1, X2, X4)	165
11.7.7 Control Panel Connection (X8)	168
11.7.8 Functional Extension Options	169
11.7.9 Control Connectors	169
11.7.10 Control Wire Sizes and Stripping Lengths	170
11.7.11 Cable Shield Connection	171
11.8 STO Installation Considerations	171

12 How to Order

12.1 Selecting the Frequency Converter	173
12.2 Model Code	173
12.2.1 Overview	173
12.2.2 Power Hardware	175
12.2.3 Optional Power Hardware (+Axxx)	176
12.2.4 Control Board Features (+Bxxx)	178
12.2.5 Functional Extension Options (+Cxxx)	179
12.2.6 Application Software and Additional Functionality (+Dxxx)	179
12.2.7 Customized Settings (+Exxx)	180
12.3 Ordering Input and Output Filters	180
12.4 Ordering Options and Accessories	180
12.5 Ordering Self-service Parts	182

1 Introduction

1.1 Purpose of this Design Guide

This design guide is intended for qualified personnel, such as:

- Project and systems engineers.
- Design consultants.
- Application and product specialists.

The design guide provides technical information to understand the capabilities of the iC7-Aqua drives for integration into management and monitoring systems for water and wastewater applications. Its purpose is to provide design considerations and planning data for integration of the drive into a system. It caters for the selection of drives and options for a diversity of applications and installations. Reviewing the detailed product information in the design stage enables developing a well-conceived system with optimal functionality and efficiency.

This guide is targeted at a worldwide audience. Therefore, wherever occurring, both SI and imperial units are shown.

1.2 Intended Use

The variable frequency drive is an electronic motor controller intended for:

- Regulation of motor speed in response to system feedback or to remote commands from external controllers. A power drive system consists of the drive, the motor, and equipment driven by the motor.
- System and motor status surveillance.

The drive can also be used for motor overload protection.

Depending on the configuration, the drive can be used in standalone applications or form part of a larger appliance or installation. The drive is allowed for use in residential, industrial, and commercial environments in accordance with local laws and standards.

NOTICE

RADIO INTERFERENCE

This product can cause radio interference.

- Take supplementary mitigation measures.

NOTICE

FORESEEABLE MISUSE

- Do not use the drive in applications which are not compliant with specified operating conditions and environments. Ensure compliance with the conditions specified in *Ambient Conditions*.

NOTICE

OUTPUT FREQUENCY LIMIT

- Due to export control regulations, the output frequency of the drive is limited to 590 Hz. For demands exceeding 590 Hz, contact Danfoss.

1.3 Additional Resources

Additional resources are available to help understand the features, and safely install and operate the iC7 products:

- Safety guides, which provide important safety information related to installing iC7 drives.

- Installation guides, which cover the mechanical and electrical installation of drives, or functional extension options.
- Operating guides, which include instructions for control options, and other components for the drive.
- Application guides, which provide instructions on setting up the drive for a specific end use. Application guides for application software packages also provide an overview of the parameters and value ranges for operating the drives, configuration examples with recommended parameter settings, and troubleshooting steps.
- [Facts Worth Knowing](#), available for download on www.danfoss.com.
- Other supplemental publications, drawings, and guides are available at www.danfoss.com.

Latest versions of Danfoss product guides are available for download at <https://www.danfoss.com/en/service-and-support/documentation/>.

1.4 Planning and Design Support Materials

1.4.1 Overview

Danfoss provides access to comprehensive product information that supports throughout the product lifecycle.

All iC7 series design guides, installation guides, safety guides, operating guides, and application guides are available for download at www.danfoss.com. It is also possible to order printed guides.

For each iC7 drive or power converter, 2D and 3D drawings, and wiring diagrams are available in standard file formats. EPLAN files with macros, technical data, and 3D models are also provided to support in the system design.

EPLAN files with macros are available for download from the EPLAN Data Portal at www.eplandataportal.com. The configurator in EPLAN Electric P8 provides access to Danfoss drive data, optimizes system design by automating the EDZ file generation and ensures precise specifications.

Configuration files for drives or power converters are also available. MyDrive® Suite provides tools that support the entire lifecycle of the product, from system design to service. MyDrive® Suite is available at <https://suite.mydrive.danfoss.com/>.

The Danfoss product configurator (available at www.danfoss.com) helps in the product selection, and when the process has been completed, the tool provides a list of relevant documentation and accessories.

Detailed product information can also be accessed by reading the 2D code on the product label.

1.4.2 Locating Support Information

Additional information is available on the company website.

1. Go to <https://www.danfoss.com>.
2. Select *Products*.
3. Select *Drives*.
4. Select the product series, for example *Low-voltage drives* or *System modules*.
5. Select the product series (for example, iC7).



The browser opens the product page, which provides links to documents, drawings, and software of the product.

1.5 Version History

This guide is regularly reviewed and updated. All suggestions for improvement are welcome.

The original language of this guide is English.

Table 1: Version History

Version	Remarks
AJ491231549263, version 0301	Updates throughout the document.
AJ491231549263, version 0201	Updates throughout the document.
AJ491231549263, version 0101	First release.

2 Safety

2.1 Safety





When designing variable frequency drives, some residual dangers cannot be avoided. One example is the discharge time, which must be observed to avoid potential death or serious injury. The discharge time is shown on the danger label on the drive.

For further information on safety precautions related to the installation, operation, or maintenance of products, refer to the product-specific installation, safety, and operating guides.

2.2 Safety Symbols

The following symbols are used in Danfoss documentation and products.

 DANGER
Indicates a hazardous situation which, if not avoided, will result in death or serious injury.
 WARNING
Indicates a hazardous situation which, if not avoided, could result in death or serious injury.
 CAUTION
Indicates a hazardous situation which, if not avoided, could result in minor or moderate injury.
NOTICE
Indicates information considered important, but not hazard-related (for example, messages relating to property damage).

	ISO warning symbol for general warnings
	ISO warning symbol for hot surfaces and burn hazard
	ISO warning symbol for high voltage and electric shock
	Symbol for indicating the required discharge time of the capacitors in the product.
	ISO action symbol for referring to the instructions

2.3 Medical Devices

 WARNING
ELECTROMAGNETIC INTERFERENCE
Drives and filters may produce electromagnetic interference up to 300 GHz that may affect the functionality of pacemakers and other implanted medical devices.

2.4 General Safety Considerations

When installing or operating the variable frequency drive, pay attention to the safety information given in the instructions. For more information about safety guidelines for installation, refer to the product-specific safety guide. For more information about safety guidelines for operating the drive, refer to the product-specific guides.

The drive is not suitable as the only safety device in the system. Make sure that additional monitoring and protection devices on drives, motors, and accessories are installed according to the regional safety guidelines and accident prevention regulations.

Keep all doors and covers closed and terminal boxes screwed on during operation of the drive and when mains is connected. Drive components and accessories can still be live and connected to mains, even after the operation indicators are no longer illuminated.

DANGER



SHOCK HAZARD FROM THE DRIVE

Touching electrical parts of the drive can cause death or serious injury even after the equipment has been disconnected from AC power.

- Perform the following steps before touching any internal components:
 - Disconnect the mains power.
 - Disconnect the motor.
 - If there is a brake option, disconnect the brake.
 - If there is a load share or regen option, disconnect it. Wait for the capacitors to discharge fully.
 - Refer to the label on the drive for the correct discharge time.
 - Ensure that the DC-link capacitors have discharged fully by measuring the DC link with a voltage meter.

WARNING



LACK OF SAFETY AWARENESS

This guide provides important information on preventing injury and damage to the equipment or the system. Ignoring this information can lead to death, serious injury, or severe damage to the equipment.

- Make sure to fully understand the dangers and safety measures present in the application.
- Before performing any electrical work on the drive, lock out and tag out all power sources to the drive.

WARNING



HAZARDOUS VOLTAGE

Drives contain hazardous voltage when connected to the AC mains or connected on the DC terminals. Failure to perform installation, start-up, and maintenance by qualified personnel can result in death or serious injury.

- Only qualified personnel must perform installation, start-up, and maintenance.

WARNING



ELECTRIC SHOCK

- Drives contain hazardous voltage when connected to AC mains, DC terminals, or motors. Failure to disconnect all power sources, including permanent magnet type motors and DC load sharing, can result in death or serious injury.

CAUTION
AUTOMATIC RESTART

The automatic restart function can cause danger.

- Before activating any automatic fault reset functions or changing limit values, make sure that no dangerous situations can occur after restart. If the auto reset function is activated, the motor starts automatically after an automatic fault reset.
- For more information on configuring automatic restart, refer to the application guide.

CAUTION

HOT SURFACES

The drive contains metal components that are still hot even after the drive has been powered off. Failure to observe the high-temperature symbol (yellow triangle) on the drive can result in serious burns.

- Be aware that internal components, such as busbars, may be extremely hot even after the drive has been powered off.
- Do not touch exterior areas that are marked by the high-temperature symbol (yellow triangle). These areas are hot while the drive is in use and immediately after being powered off.

2.5 Qualified Personnel

To allow trouble-free and safe operation of the unit, only qualified personnel with proven skills are allowed to transport, store, assemble, install, program, commission, maintain, and decommission this equipment.

Persons with proven skills:

- Are qualified electrical engineers or persons who have received training from qualified electrical engineers and are suitably experienced to operate devices, systems, plants, and machinery in accordance with pertinent laws and regulations.
- Are familiar with the basic regulations concerning health and safety/accident prevention.
- Have read and understood the safety guidelines given in all guides provided with the unit, especially the instructions given in the operating guide of the drive.
- Have good knowledge of the generic and specialist standards applicable to the specific application.

3 Approvals and Certifications

3.1 Product Approvals and Certifications

iC7 product series complies with the required standards and directives. For detailed information on which approvals and certifications a product has, see the product label and <https://www.danfoss.com>.

Certificates and Declarations of Conformity are available on request or at <https://www.danfoss.com>.

Table 2: Approvals and Certifications Applicable to Drives

Approval	Description
	<p>The drive complies with relevant directives and their related standards for the extended Single Market in the European Economic Area. The drive also complies with relevant regulation and their related standards for Great Britain.</p> <p>UKCA contact information:</p> <p>Danfoss, 22 Wycombe End, HP9 1NB, Great Britain</p>
	<p>The Underwriters Laboratory (UL) mark indicates the safety of products and their environmental claims based on standardized testing. Drives of voltage 525–690 V are UL-certified for only 525–600 V. The drive complies with UL 61800-5-1.</p> <p>The UL file number for iC7-Aqua drives is E506002.</p>

Table 3: EU Directives Applicable to Drives

EU Directive	Description
Battery Regulation (2023/1542)	The Battery Regulation 2023/1542 establishes harmonized legislation for batteries placed on the EU market. It sets mandatory requirements for the sustainability, safety, labeling, and disposal of batteries.
EMC Directive (2014/30/EU)	The purpose of the EMC (electromagnetic compatibility) Directive is to reduce electromagnetic interference and enhance the immunity of electrical equipment and installations. The basic protection requirement of the EMC Directive states that devices that generate electromagnetic interference (EMI), or whose operation could be affected by EMI, must be designed to limit the generation of electromagnetic interference and shall have a suitable degree of immunity to EMI when properly installed, maintained, and used as intended. Electrical equipment devices used alone or as part of a system must bear the CE mark. Systems do not require the CE mark, but must comply with the basic protection requirements of the EMC Directive.
ErP Directive (2009/125/EC)	The ErP Directive is the European Ecodesign Directive for energy-related products. The directive sets ecodesign requirements for energy-related products, including drives, and aims at reducing the energy consumption and environmental impact of products by establishing minimum energy-efficiency standards.
Low Voltage Directive (2014/35/EU)	The aim of the Low Voltage Directive is to protect persons, domestic animals, and property against dangers caused by the electrical equipment, when operating electrical equipment that is installed and maintained correctly, in its intended application. The directive applies to all electrical equipment in the 50–1000 V AC and the 75–1500 V DC voltage ranges.

Table 3: EU Directives Applicable to Drives - (continued)

EU Directive	Description
Machinery Directive (2006/42/EC)	The aim of the Machinery Directive is to ensure personal safety and avoid property damage to mechanical equipment used in its intended application. The Machinery Directive applies to a machine consisting of an aggregate of interconnected components or devices of which at least 1 is capable of mechanical movement. Drives with an integrated functional safety function must comply with the Machinery Directive. Drives without a functional safety function do not fall under the Machinery Directive. If a drive is integrated into a machinery system, can provide information on safety aspects relating to the drive. When drives are used in machines with at least 1 moving part, the machine manufacturer must provide a declaration stating compliance with all relevant statutes and safety measures.
RoHS Directive (2011/65/EU)	The Restriction of Hazardous Substances (RoHS) Directive is an EU directive that restricts the use of hazardous materials in the manufacturing of electronic and electrical products. Read more on www.danfoss.com .
Waste Electrical and Electronic Equipment Directive (2012/19/EU)	The Waste Electrical and Electronic Equipment Directive (WEEE Directive) sets collection, recycling and recovery targets for all types of electrical goods.

3.2 Standards

Installation must be in accordance with national regulations, for example NEC NFPA 70, or IEC 60364 series of standards.

The following standards are recommended as guidelines for the installation and operation of drives:

- **EN IEC 61800-2:2015 Adjustable speed electrical power drive systems - Part 2:** General requirements - Rating specifications for low voltage adjustable speed AC power drive systems.
- **IEC 61800-3:2022 Adjustable speed electrical power drive systems - Part 3:** EMC requirements and specific test methods.
- **EN IEC 61800-5-1:2017/IEC 61800-5-1 ed 3.0:2022 Adjustable speed electrical power drive systems - Part 5-1:** Safety requirements - Electrical, thermal, and energy.
- **EN IEC 61800-9-2:2017 Adjustable speed electrical power drive systems - Part 9-2:** Ecodesign for power drive systems, motor starters, power electronics and their driven applications - Energy efficiency indicators for power drive systems and motor starters.

Declarations of Conformity are available at www.danfoss.com/en/service-and-support/documentation/.

3.3 Export Control Regulation

Variable frequency drives can be subject to regional and/or national export control regulations. Both the EU and US have regulations for so-called dual-use products (products for both military and non-military use), which currently includes drives with a capacity to operate from 600 Hz upwards. These products can still be sold, but it requires a set of measures, for example a license, or an end-user statement.

The US also has regulations for drives with a capacity to operate 300–600 Hz with restrictions on sales for certain countries. US regulations apply to all products manufactured in the US, exported from or via the US, or with a US content of more than 25%, or 10% for some countries. An ECCN number is used to classify all drives that are subject to export control regulations. The ECCN number is provided in the documentation accompanying the drive. If the drive is re-exported, it is the responsibility of the exporter to ensure compliance with the relevant export control regulations.

For further information, contact Danfoss.

4 Danfoss iC7 Series

4.1 Overview of iC7 Series

The Danfoss iC7 comprises 5 products that combine hardware and software:

- iC7-Automation
- iC7-Hybrid
- iC7-Marine
- iC7-Aqua
- iC7-HVACR

The series consists of 3 hardware variants:

- Frequency converters
- Enclosed drives
- System modules

The drives have preinstalled application software matching the needs of the intended application. Alternative application software packages can be purchased, and some application software is only available for specific hardware variants.

For detailed information about the application software, refer to the application guides.

4.2 Ecodesign for Power Drive Systems

4.2.1 Overview

Energy-efficiency of the overall system is important and covered by the international standard IEC 61800-9-2. In some locations, such as the European Economic Area, compliance with minimum efficiency standards is regulated and legally required.

Frequency converters are classified by efficiency classes IE0 to IE2 according to IEC 61800-9-2. According to the standard, power losses are measured as percentages of the rated apparent output power at 8 load points as shown in [Figure 1](#).

Together with information about other elements of the system, this information can be used to calculate a system level efficiency (IES).

Elements causing losses are described in [4.2.2 Power Losses and Efficiency](#).

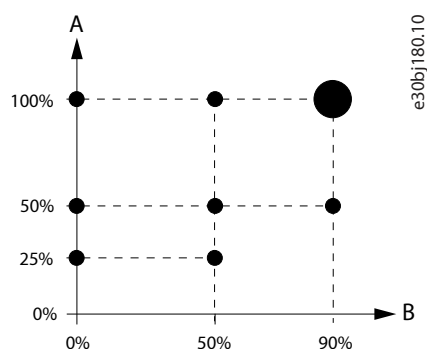

Figure 1: Operating Point According to IEC 61800-9-2

A	Relative torque producing current	B	Relative rated motor stator frequency
---	-----------------------------------	---	---------------------------------------

The frequency converter is labeled with the efficiency class and the power losses at 100% rated torque-producing current and 90% rated motor stator frequency.

[MyDrive® Energy](#) can be used to:

- Look up part load data as defined in IEC 61800-9-2.

- Calculate the efficiency class and part load efficiency for the frequency converter and the power drive system (systems consisting of a frequency converter, motor, and output filters).
- Create a report documenting part load loss data and IE and IES efficiency class.

4.2.2 Power Losses and Efficiency

Elements causing power loss in the system are shown in [Figure 2](#).

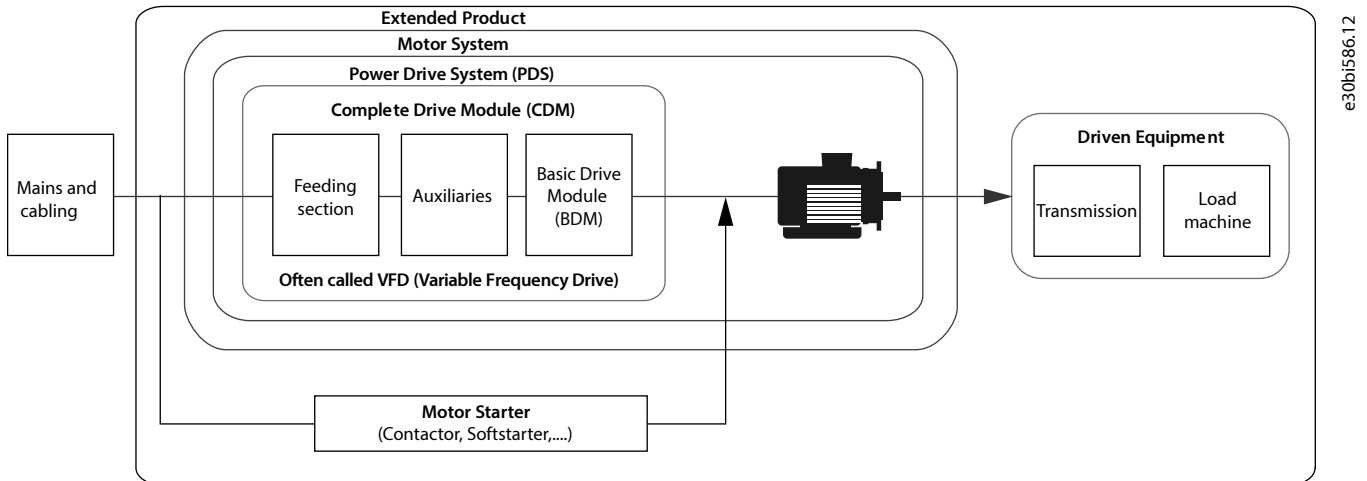

Figure 2: Drive System Design

The frequency converter itself only provides a part of the total losses of the system. The following components can cause losses in the system:

- Mains supply cable
- External input filter (optional)
- Frequency converter (including built-in filters)
- External output filter (optional)
- Motor cable
- Motor

Losses in the mains supply cable are mainly caused by the ohmic resistance of the cable. To keep the losses at a minimum, the cable length should be kept short and sized properly to the rated current.

Externally added input filters add to the losses in the system. Line reactors used to balance the phase load provide load-dependent losses of up to 1–2% of full power. Dedicated harmonic filters have losses of 2–5% of maximum power. Reducing harmonic distortion reduces the losses in the external cabling and transformers, resulting in lower system loss.

The loss of the frequency converter, also known as the basic drive module (BDM), is load-dependent. Specific classifications and power loss data are shown on the product label, and details can be seen in [MyDrive® Energy](#).

Specific information on the frequency converter can be found in [8.7 Energy Efficiency Data](#).

Externally connected output filters add losses to the system:

- Sine-wave filters suppress the pulse-width modulation (PWM) pattern of the output frequency, resulting in a sine-wave output. The resulting loss is load-dependent and can be up to 1–1.5% of maximum power. Using a sine-wave filter in installations with long motor cables reduces cable loss.
- dU/dt filters increase the rise time of the PWM pattern, limiting dU/dt. As a result, the filters introduce loss in the system. The loss is load-dependent and can be up to 0.5–1% of maximum power.
- Common-mode cores mitigate high-frequency noise in the motor cable. As a result, a minor power loss is added to the system.

Losses in the motor cable are mainly caused by ohmic losses, but due to the switching frequency of the frequency converter, losses are also caused by capacitive coupling between phases and to ground. Losses due to capacitive coupling can be reduced by carefully selecting the motor cable and keeping the cable length as short as possible. If a sine-wave filter is used on the frequency converter output, the loss caused by capacitive load is reduced.

Motor losses depend on the motor type and efficiency category selected. IEC 60034-30-1 defines the different efficiency classes from IE1 to IE4.

5 iC7 Frequency Converters

5.1 Overview

The iC7 frequency converter is built as a modular, configurable drive, which can be complemented with functional extensions to match application needs. All options are configurable and can be selected when ordering the drive. Functional extensions, fieldbuses, and additional software can also be added later as a field upgrade.

The drive consists of a power unit, a control unit, and an application software package. In addition, a range of options and accessories are available. The available application software packages and features are described in chapter *iC7-Aqua Application Software*.

5.2 Drive Models and Frame Designations

The iC7 frequency converters have a frame designation that indicates the characteristics of the products. The designations are used in this guide in illustrations and technical data, for example.

The frame designation consists of 4 or 5 characters, for example **FA04b**:

- The 1st character is fixed, and indicates that the hardware provides frequency converter functionality. For iC7 series frequency converters, **F** is used as the first character.
- The 2nd character indicates the protection rating:
 - **A**: IP20/UL
 - **K**: IP21/UL Type 1
 - **B**: IP54/UL Type 12 or IP55/UL Type 12
- The 3rd and 4th characters are a running number 02–12. The number is linked to a specific frame of the product, which is used, for example, in the current rating tables.
- The 5th character is optional, and is only for frames that have specific variants and therefore different dimensions:
 - **a**: Standard depth and height
 - **b**: Extended depth
 - **c**: Extended height

The dimensions of each frame type are given in [Exterior and Terminal Dimensions](#).

Examples of frame designations used in this guide:

- Frame designation FA04b translates into an IP20/UL Open Type frame 04 with extended depth.
- Frame designation FK06 translates into an IP21/UL Type 1 frame 06.
- If the reference in an illustration, text, or table applies to all variants, the 2nd character is replaced with an **x**, for example Fx06, indicating FA06, FK06, and FB06.
- If the reference is to all variants of a specific rating, the reference is described with the first 2 characters only, for example **FA** indicating all frames from FA02 to FA12 with the IP20/UL Open Type protection rating.

5.3 Power Unit

The drives are designed to fit a wide variety of installation locations, and are available in different protection ratings, making them suitable for installation in cabinets, directly on machines, in dedicated control rooms, and freely installed.

- IP20/UL Open Type frames are designed for installation in enclosed cabinets and similar setups.
- IP21/UL Type 1 frames are designed for indoor installations.
- IP54/IP55/UL Type 12 frames are designed for use in protected areas where the drive is exposed to both dust and water.

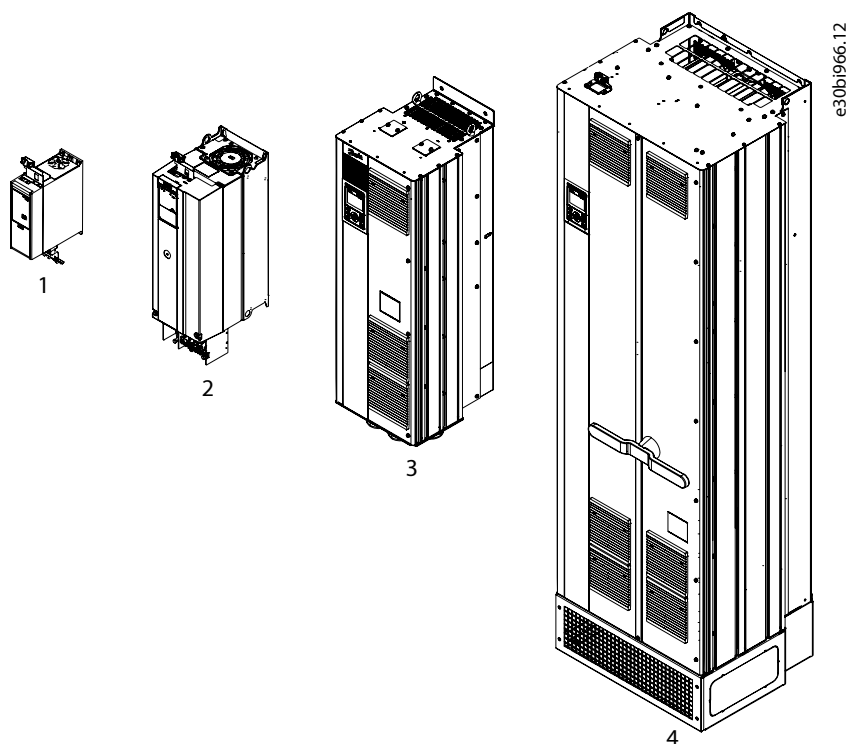

1	IP20/UL Open Type, FA02	2	IP20/UL Open Type, FA06
3	IP21/UL Type 1, FK09	4	IP54/IP55/UL Type 12, FB11

Figure 3: Frame Offering in the iC7-Aqua Range

The frame variants are identified by a 4–5 character designation, where the first 2 characters indicate the protection rating, and the remaining characters indicate physical dimensions of the frame. For details on the characters in the frame designation, see [5.2 Drive Models and Frame Designations](#).

The drives are suitable for use in a wide temperature range. The standard operating temperature range for 6-pulse drives is from -30 °C up to +45 °C (-22 °F to +113 °F) when operating in low overload, and from -30 °C to +50 °C (-22 °F to +122 °F) when operating in high overload. With derating, the maximum operating temperature is increased to 60 °C (140 °F). Ultra low-harmonic (ULH) drives are rated to a maximum of 40 °C (104 °F). With derating, the maximum operating temperature is increased to 50 °C (122 °F) for ULH drives. For more information on derating, see [10.6.1 Overview](#).

The drives are designed for operation in altitudes up to 4400 m (14400 ft). Derating should be considered for altitudes above 1000 m (3280 ft).

IP20/UL Open Type frames (up to 43 A, 400 V) have pluggable power connectors to make installation and service exchange easy.

The motor output is protected against short circuit, ground fault, and overload. Thermal monitoring is also provided to protect the motor. Unlimited switching on output enables using a contactor or disconnects between the drive and the motor. The drives can operate motors connected in parallel.

Drives rated for 206 A and up (Fx09–Fx12, 400 V) use back-channel cooling, where cooling air is ducted out from the cabinets or cooling rooms, reducing the need for extra cooling. Heat pipe technology is applied in heat sinks in frames Fx09–Fx12.

Integrated filters optimize EMC performance, reduce harmonics on the grid, and match with output requirements:

- Built-in EMC filters can be configured to fit the EMC-related installation requirements. The offering covers drives without filter, filters for use in industrial networks (C3 and C2 compliant variants), and filters compliant to domestic installations (C1 compliant). The maximum motor cable length for installations is 300 m (984 ft). For details on cable lengths, see [8.9 Cable Length](#).
- All 6-pulse drives have a built-in DC-link filter, which reduces the harmonic distortion on the grid. Ultra low-harmonic drives offer active filtering of harmonics.

- External dU/dt filters, sine-wave filters, harmonic filters, and common-mode HF filters are available as optional accessories. For more information about the filters, see [Input and Output Filters](#).

5.4 Power Unit Options

The product architecture allows adding configurable hardware options, which increase the robustness of the installation:

- An optional mains switch allows for the manual disconnect of mains power, which increases safety during service. The mains switch is interlocked with the cabinet cover or door to prevent them from being opened while power is still applied. If the mains switch is selected when ordering a drive, it is preinstalled in the drive.
- Optional built-in fuses that offer extra protection against failures inside the drive are available for IP21 and IP54/IP55 drives and for IP20 frames Fx09–Fx12.
- An optional touch protection in front of the power terminals adds extra protection against accidental contact when the enclosure door is open. If the touch protection option is selected when ordering frames FK09–FK12 and FB09–FB12, it is preinstalled in the drive from the factory. Touch protection kits can also be ordered as an accessory and installed as a field upgrade.
- The drives are designed to meet the typical conditions for indoor installation and use. If the drive is exposed to harsher environments, coated printed circuit boards can be selected to have more protection against the environment. Frames Fx09–Fx12 have coated printed circuit boards as a standard option.
- A heat sink access panel is available for drives in the range from 206 A and up (Fx09–Fx12, 400 V) and allows easy access to clean the heat sink fins in the cooling channel.

5.5 Control Unit and Interfaces

The drive has an integrated control unit, which consists of a control board with integrated functional safety, integrated communication ports, option slots for additional option boards, and a control panel.

iC7-Aqua drives are available with different control board variants with different interfaces:

- Standard control board with an RS-485 interface (B5S)
- Standard control with a dual Ethernet interface (B5E)
- Advanced control board with an RS-485 interface (A5S)
- Advanced control board with a dual Ethernet interface (A5E)

The default selection is the standard control board with the selected communication interface. The standard control board (B5S, B5E) includes 1 functional extension option slot. If more than 1 option is required, the advanced control board (A5S, A5E) is used. If upgrading to 2 or more options is expected later, a drive with the advanced control board should be selected when configuring the drive.

Ethernet port X0 is used for connecting the drive to a PC or similar tools used for commissioning or service.

The control board with the RS-485 port (X4) and the control board with Ethernet ports X1 and X2 allow connecting to fieldbus systems, with support for daisy-chaining and single connections. Communication protocols can be selected when ordering the drive, or alternatively, communication protocols can be activated later with a proof-of-purchase token. If a protocol is selected when ordering a drive, the protocol is preconfigured in the drive from the factory. For more information on the features of each control board, see [Table 4](#).

Table 4: Control Board Features

Feature	Control board			
	Standard serial (B5S)	Advanced serial (A5S)	Standard Ethernet (B5E)	Advanced Ethernet (A5E)
Ethernet port (for service)	X0	X0	X0	X0
Communication protocol	Serial (RS-485)		Dual Ethernet	

Table 4: Control Board Features - (continued)

Feature	Control board			
	Standard serial (B5S)	Advanced serial (A5S)	Standard Ethernet (B5E)	Advanced Ethernet (A5E)
Communication interfaces for fieldbus	X4		X1, X2	
Supported fieldbus protocols ⁽¹⁾	Modbus RTU		Modbus TCP, PROFINET RT, EtherNet/IP, EtherCAT	
24 V external supply	–	X	X	X
I/O configuration	4 DI, 2 combined DI/DO, 2 AI, 1 AO, 2 x relay			
Real-time clock with battery backup	X	X	–	X
SD card reader	–	X	–	X
Number of option slots	1	2–4 ⁽²⁾	1	2–4 ⁽²⁾

1) See [12.2.4 Control Board Features \(+Bxxx\)](#) for a list of available fieldbus protocols.

2) The number of option slots varies between frames. For details, see [7.3.2 Option Slots](#).

See [Figure 4](#) for an illustration of the control unit mechanics.

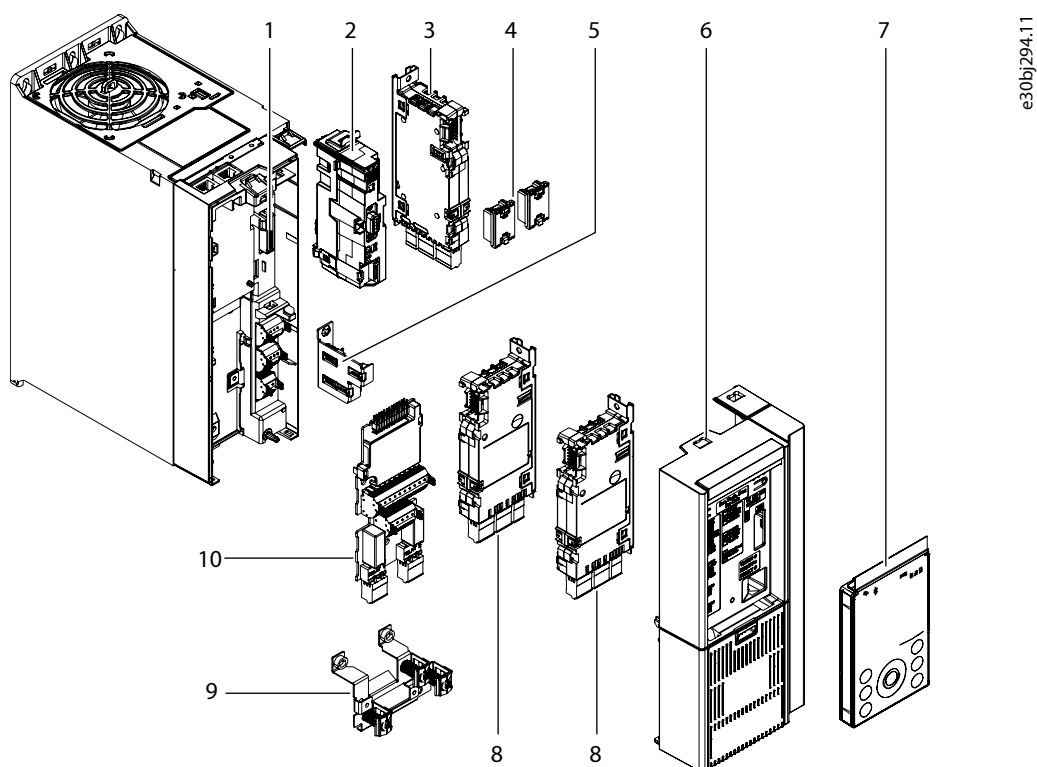

1	Control board	2	Interface board
3	Option placed in slot C	4	Option connectors
5	EMC plate	6	Terminal cover
7	Control panel	8	Options placed in slots A and B
9	EMC plate	10	Basic I/O board

Figure 4: Control Unit Mechanics for iC7-Aqua Frequency Converters with the Advanced Control Board (A5S, A5E)

iC7-Aqua is delivered with the Aqua application software package and the selected fieldbus protocol. Updates can be made later with a proof-of-purchase token.

5.6 Control Panels

The iC7 series offers user interfaces to suit different operational needs.

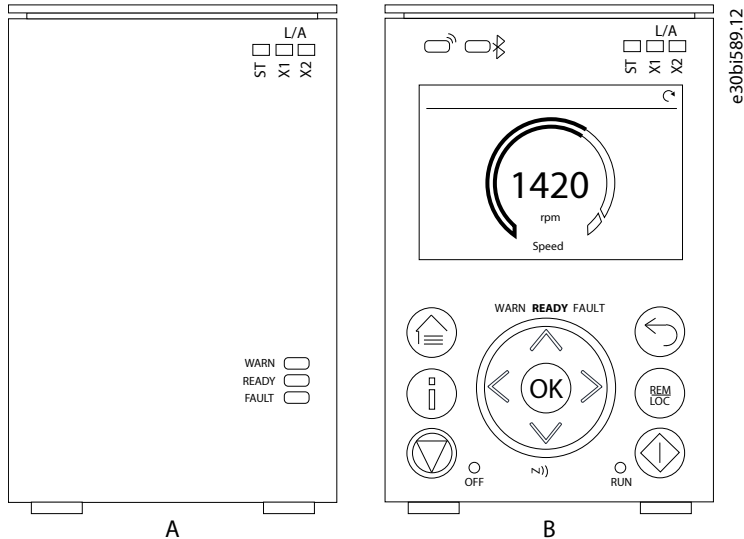

Figure 5: Control Panel Options

- Blind Panel OPX00:** The Blind Panel has indicators showing the status of the drive and the fieldbus connection. It is typically used when limited interaction is required with the drive after installation and commissioning, or when the drives are controlled by fieldbus.
- Control Panel 2.8 OPX20:** The Control Panel 2.8 is typically used when regular interaction with the drive is expected. The Control Panel 2.8 has the basic status and fieldbus indicators, a 2.8 inch graphical display, and tactile feedback buttons. The halo around the navigation buttons indicates the drive status and is visible from a long distance.

Mounting kits are available for external mounting of control panels. For more information, see [7.5.4 Control Panel Mounting Kits and Cables](#).

5.7 Functional Safety

A galvanic isolated, dual channel Safe Torque Off (SIL 3, PL e) input is offered as standard in the drive. It also contains an STO feedback output that can be used as a status signal, or as a diagnostic signal to external safety equipment. This version of functional safety cannot be upgraded in the field.

5.8 Overload Capability

5.8.1 Load Profile Overview

When selecting a drive, it is important to know the load characteristic and load cycle of the application to ensure optimal performance.

The output current rating is selected based on the application load profile. In addition, derating of the output current may be needed, for example, if operational temperature is increased, or the drive is installed in an altitude above 1000 m (3300 ft). For more information on derating, see [Derating for Operating Conditions](#).

iC7-Aqua drives are rated with 2 output current categories:

- Low overload (LO):** 110% load for 1 minute every 10 minutes.
- High overload (HO1):** Up to 150% load for 1 minute every 10 minutes, with a break-away torque of up to 200%.

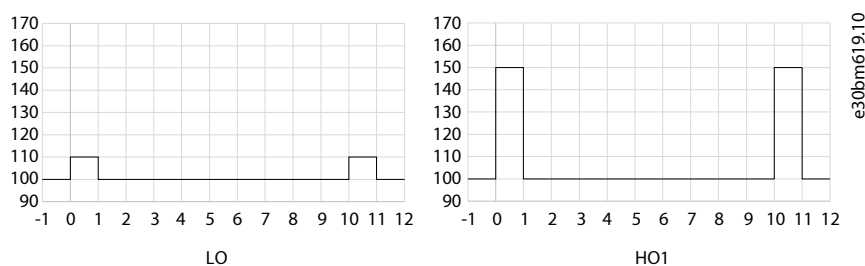

Figure 6: Low Overload and High Overload Curves

For the startup of motors, a short time break-away torque can be applied for 2 s (frames Fx02–Fx08) or 3 s (frames Fx09–Fx12). The rating depends on setting and actual current rating.

For ratings of the drives at rated voltage and frequency, see [8.2.2 Ratings for Frequency Converters with 380–480 V Supply Voltage](#).

MyDrive® Select can also be used to support the selection, including calculations and optimizations, of the drive.

5.8.2 Low Overload (LO)

The low-overload profile supports applications running at a non-varying or slowly varying load, where a limited overload capability is required. It is typically used in applications with a variable torque load.

The low-overload profile allows the drive to run at **110% load for 1 minute every 10 minutes**.

Typical applications where the low-overload profile is used are:

- Fans
- Centrifugal pumps
- Blowers and aerators
- Screw compressors
- Mixers

5.8.3 High Overload (HO1)

The high-overload profile is typical for applications which require higher short-term overload and constant torque operations.

When operated in the high-overload mode, the drive output rating is defined for 1 motor size down compared to the low-overload profile.

With the high-overload profile, the drive is able to run with a load of **up to 150% for 1 minute every 10 minutes, with a break-away torque of up to 200%**, depending on size. For drive-specific data, see [Ratings](#).

Typical applications where the high-overload profile is used are:

- Decanter/centrifuge
- Piston compressors
- Piston pumps
- High-pressure pumps
- Mixers
- Agitators

6 iC7-Aqua Application Software

6.1 Basic Functions

6.1.1 I/O Control and Statuses

Depending on the hardware configuration of the drive, digital and analog inputs as well as digital, analog, and relay outputs are available. The I/Os can be configured and used to control the application from the drive.

If functional extension options are installed in the drive, the relevant parameters and I/O selections are automatically visible in the parameter structure.

6.1.2 Reference Handling

References from multiple sources can be defined, depending on the needs of the application.

Reference sources are:

- Analog inputs
- Digital inputs as pulse input
- Fieldbus
- Up to 8 speed presets, 4 torque presets, or 8 process presets, each individually configurable (selectable by parameter, fieldbus, or digital inputs)
- Local reference from control panel
- Logic reference

Reference signals can be individually configured and scaled for every operating mode (speed, torque, and process). They can be added, subtracted, and multiplied, generating the reference to the drive.

6.1.3 Ramps

Ramps provide a constant acceleration and deceleration. In addition, the drive supports pump-specific ramps, which are useful for lubrication-sensitive pumps and for protecting check valves from rapid closure.

6.1.4 Limit Rotation Direction

The motor can be preset to run in 1 rotational direction only (positive or negative), avoiding unintended rotation direction.

6.1.5 Speed Bypass

Specific motor speeds can be bypassed during operation. The feature helps to minimize or avoid mechanical resonance of the machine, limiting the vibration and noise of the system.

6.1.6 Flying Start

Flying start enables the drive to synchronize to a freely spinning motor, before taking control of the motor. Taking over control of the motor at the actual speed minimizes mechanical stress to the system. This feature is relevant in fan and centrifuge applications, for example.

6.1.7 Kinetic Backup

Kinetic backup enables the drive to remain in control in the event of a power outage if there is sufficient energy in the system, such as inertia or when lowering a load. The function allows a controlled stop of the machine.

6.1.8 Motor Preheating

In cold and damp environments, the motor must be preheated to avoid condensation and cold starts. The feature DC Start generates a DC current through the motor windings, keeping the temperature above the surrounding temperature.

6.2 Controllers

6.2.1 Speed Controller

A built-in speed controller provides accurate control of the rotational speed of the motor.

The speed controller does not require an external sensor for measuring the feedback signal. This allows easy installation and commissioning and eliminates the risk of defective sensors.

6.2.2 Process Controller

The process controller can control a process in a system where a constant pressure, flow, or temperature is needed, for example. Feedback from the application is connected to the drive, providing the actual process value. The controller ensures that the output matches the desired speed reference. The reference source and the feedback signals are converted and scaled to the actual values controlled. The controller provides full PID control, which includes PID parameter configuration, and is optimized by the built-in auto-tuning function.

6.3 Water, Wastewater, and Irrigation Features

6.3.1 Initial, Final, and Check Valve Ramps

In addition to standard motor ramps, the drive provides extended ramp support to optimize use with pumps.

- The initial ramp enables a fast ramp-up to a minimum speed to avoid running below minimum speed for too long.
- The check valve ramp prevents water hammering when stopping the pump, by ensuring slow pump speed ramp-down just as the check valve is almost shut.
- The final ramp prevents running at low speed for too long.

6.3.2 Dry Run

The dry run feature continuously monitors the pump and makes sure that the pump does not run dry on the suction side.

6.3.3 No-Flow Curve

A no-flow curve can be generated by a built-in power curve generation feature, or alternatively, by adding information on 2 load points on the pump curve. The curve provides the foundation for functionality related to the no-flow or low-flow conditions.

6.3.4 Sleep Mode

The sleep mode feature enables energy savings by not energizing the motor, when there is no need for flow. It still monitors and secures the needed pressure of the system and wakes up when flow is required.

6.3.5 End of Curve

If the drive detects that a given setpoint cannot be reached, for example, if there is a leakage in the pipe, it provides a message that it is not possible to reach the setpoint, and appropriate actions can be selected.

6.3.6 Low Reference Monitor

The low reference monitor is an energy saving feature, which prevents energizing the motor, if it is not required. The feature detects if the speed is below a specified reference limit, and if it is, the motor is de-energized.

6.3.7 Auxiliary PID with Autotuning

In addition to controlling, for example, the flow or pressure for a pump, the drive offers 3 auxiliary PID controllers. The auxiliary PID controllers can be used to control external valves without external control hardware.

The PID includes autotuning, making setup easy for the application.

6.3.8 Flow Confirmation

The flow confirmation monitor protects equipment from unexpected flow stoppage. If no signal is present from an external valve or flow switch, the drive trips after a given flow verification time.

6.3.9 Run Permissive

The run permissive feature prevents the motor from starting before external conditions are fulfilled, for example, a valve is to be opened before the pump is started.

6.3.10 Multi-Pump Control

The drive offers a multi-pump control, enabling control of staging up to 5 fixed-speed pumps to provide an optimum output from the pumps. The use of each pump is managed to ensure a balanced run-time of the pumps.

6.4 Motor Control Features

6.4.1 Motor Types

The drive supports standard available motors, such as:

- Induction motors (IM)
- Permanent magnet motors (PM)

6.4.2 Torque Characteristics

Different load characteristics are supported to match the actual application needs:

- **Variable torque:** Typical load characteristic of fans and centrifugal pumps, where the load is proportional to the square of the speed.
- **Constant torque:** Load characteristic used in machinery where torque is needed across the full speed range.

6.4.3 Motor Control Principles

Different control principles can be selected to control the motor, matching the needs of the application:

- U/f control for simple open-loop operation.
- VVC+ (Voltage Vector Control) in both open and closed loop, for general-purpose application needs.

6.4.4 Motor Nameplate Data

Typical motor data for the drive are preset at the factory, matching the size of the drive. The preset data allow operation of most motors. During commissioning, actual motor data are entered in the settings of the drive to optimize motor control.

6.4.5 Automatic Motor Adaptation (AMA)

Automatic Motor Adaptation (AMA) optimizes motor parameters for improved shaft performance and energy efficiency. Based on motor product label data and measurements of the motor at standstill, key motor parameters are recalculated to fine-tune the motor control algorithm.

6.4.6 Automation Energy Optimization (AEO)

The Automatic Energy Optimization (AEO) feature optimizes control with focus on lowering energy consumption at the actual load point.

6.4.7 Braking of Load

6.4.7.1 Overview of Braking of Load

For controlled load braking performed by the drive, various functions can be used. The specific function is selected based on the application and how fast the load has to be stopped.

6.4.7.2 Overvoltage Control (OVC)

If braking time is not critical or the load is varying, the overvoltage control (OVC) feature can be used to control the stopping of the application. The drive extends the ramp-down time when it is not possible to brake within the defined ramp-down period.

6.4.7.3 DC Brake

The DC brake feature is useful when braking at low speed. The drive offers configurable DC-braking for induction motor control. It injects a user-defined DC current.

6.4.7.4 AC Brake

In applications where the operation of the motor is non-cyclic, AC braking can be used to shorten the braking time. Excess energy is dissipated by increasing losses in the motor during braking. Performance is motor type dependent and offers best performance on induction motors.

6.4.7.5 DC Hold

The drive offers the possibility to configure the feature DC Start for DC holding before entering normal motor control.

6.5 Protection Features

6.5.1 Grid Protection

The drive protects the application against conditions in the power grid that can affect proper operation. The grid is monitored for phase imbalance and phase loss. When the imbalance exceeds specified limits, the drive issues a configurable response and appropriate actions can be taken.

The supply frequency is also monitored, and when it is outside acceptable limits, the drive responds in the configured way. Furthermore, the drive offers protections against low and high voltages.

6.5.2 Drive Protection

The drive monitors and protects itself at all times.

Built-in temperature sensors measure the temperature of relevant components. If the temperature is close to the maximum, derating of operational parameters is applied to keep the application running, though at a lower performance level. If the temperature is outside the allowed operating range, the drive stops operation.

The motor current is continuously monitored on all 3 phases. If there is a short circuit between 2 phases, or to ground, the drive detects the short circuit and immediately turns off. If the output current is exceeding its nominal values during operation for longer periods than allowed, the overload capability is reduced until the conditions are restored.

The DC-link voltage of the drive is monitored. If it exceeds critical levels, the drive issues a warning. If the situation is not resolved, the drive stops operation.

6.5.3 Motor Protection

The drive provides various features to protect the motor, and indirectly the application.

The output current measurement provides information to protect the motor. Overcurrent, short circuit, ground faults, and lost motor phase connections can be detected and relevant protections initiated.

The monitoring of speed, current, and torque limits provides an extra protection for the motor and the application. Under extreme load conditions, it also provides motor stall protection.

Locked-rotor protection secures that the drive does not start when the rotor of the motor is blocked.

Motor thermal protection is provided either as a calculation of the motor temperature based on the actual load, or by external temperature sensors connected to the drive. Supported sensor types are Pt100, Pt1000, Ni1000, KTY84, and KTY81.

6.5.4 Protection of External Filters

The drive can also monitor the temperature of externally connected filters.

6.5.5 Automatic Derating

Automatic derating of the drive allows continued operation even if the nominal operation conditions are exceeded. It is a response to exceeded limits in the grid, motor, and self protection features of the drive. Typical factors affecting operation are high temperature, high DC-link voltage, high motor load, or operation close to 0 Hz. Derating is typically applied as a reduction in switching frequency or change in switching pattern, resulting in lower thermal losses.

6.6 Monitoring, Logging, and History Log

6.6.1 Monitoring Features

The drive offers a wide range of monitoring features that provide information of actual operating conditions. Some examples are:

Speed monitoring

The motor speed can be monitored during operation. If the speed exceeds minimum or maximum limits, a notification is triggered and appropriate actions can be initiated.

Temperature monitoring

Temperatures of the drive and external connected sensors can be monitored. The temperature monitoring feature enables monitoring the operational conditions of the drive and the related application.

Grid monitoring

During operation, the drive is able to monitor the grid conditions. It measures the grid voltage for each supply phase and the grid frequency, and calculates the grid voltage imbalance and total harmonic distortion (THDv).

6.6.2 Event Log

An event log provides access to the latest registered warnings and faults, providing relevant information for analysis of the events that occur in the drive.

6.6.3 Logging and Storage of Data

Logging of operational data from the drive and the related process is possible during running. Logging can be continuous or triggered by specific events. Data is transferred directly to MyDrive Insight. This feature provides the opportunity to collect data for a detailed analysis of operation and the events happening during operation.

6.6.4 Preventive Maintenance

Elements in the application must be inspected and serviced periodically because of wear and tear during operation. For example, motor bearings, feedback sensors, seals, and filters are subject to wear and must be serviced or replaced. With preventive maintenance, the service intervals can be programmed into the drive. The drive issues a warning when maintenance is required.

10 preventive maintenance items can be programmed into the drive. The following information must be specified for each item:

- The type of the trigger that activates the maintenance (for example Running hours)
- Maintenance interval (for example 1000 hours)

The parameters can also be set individually via fieldbus.

6.7 Security Features

NOTICE

Do not connect the drive directly to the internet, as end-to-end connectivity is not secured via Danfoss software tools. It is recommended that drives are installed by authorized and educated personnel, who are aware of the security risks in networks and can mitigate threats in the network. Typically, the drive can be accessed and configured by anyone with physical access.

The drive provides the following cybersecurity features:

- Secure boot chain
- Signed and encrypted firmware and application software
- Secure software updates
- License verification
- Secure connectivity for all communication interfaces

6.8 Software Tools

6.8.1 Overview

Danfoss offers a suite of desktop software tools which have been designed to provide easy operation and the highest level of customization of variable frequency drives.

The MyDrive® tools support the entire lifecycle of the drive, from system design to service. Some of the tools are available free of charge, and some require a subscription.

For more information about the MyDrive® tools, see MyDrive® documentation.

6.8.2 MyDrive® Select

MyDrive® Select performs frequency converter sizing based on calculated motor load currents, ambient temperature, and current limitations. The sizing results are available in graphical and numerical format, and include calculations of efficiency, power losses, and inverter load currents. The resulting documentation is available in .pdf or .xls format, and can be imported to MyDrive® Harmonics for evaluation of the harmonic distortion, or validation of compliance towards most recognized harmonic norms and recommendations.

MyDrive® Select is available as a web-based tool at select.mydrive.danfoss.com and as a mobile device app that can be downloaded from app stores.

6.8.3 MyDrive® Harmonics

MyDrive® Harmonics estimates the benefits of adding harmonic mitigation solutions to an installation and calculates system harmonic distortion. The evaluation can be done both for new installations and when extending an existing installation.

The free version provides a fast overview of the expected general performance of the system. The expert version of MyDrive® Harmonics requires a subscription, which opens up more features, including the possibility to save and share harmonic projects, import projects from MyDrive® Select, and the possibility to add Danfoss harmonic mitigation products.

MyDrive® is available as a web-based tool at <https://harmonics.mydrive.danfoss.com>.

6.8.4 MyDrive® Energy

MyDrive® Energy combines drive system energy calculation and efficiency classification functionalities in 1 tool. It uses basic system parameters to generate efficiency metrics and estimate potential energy savings and CO₂ reduction for drive systems.

- The Efficiency Calculator (formerly MyDrive® ecoSmart) follows IEC 61800-9-2 standards for IE and IES class definitions, and calculates efficiency class and part load efficiency for Danfoss drives.

- The Energy Calculator enables system-level efficiency assessments, and analyzes energy consumption and savings. Additional parameters such as energy costs, CO₂ emissions, and system-specific load profiles can be added to obtain more precise results.

MyDrive® Energy is available as a web-based tool at <https://energy.mydrive.danfoss.com/>.

6.8.5 MyDrive® Insight

MyDrive® Insight is a software tool for commissioning, engineering, and monitoring drives. MyDrive® Insight can be used to configure parameters, upgrade software, and set up functional safety features and condition-based monitoring.

MyDrive® Insight is available for download at <https://suite.mydrive.danfoss.com/>.

Logic

The Logic feature in MyDrive® Insight enables the customization and control of drives through a graphical user interface without the need for a separate programming tool. It allows for conditional controls, fault detection and diagnostics, and the creation of sequencing and interlocking logic. Programmable function blocks with inputs and outputs can be connected to control the digital or analog outputs of the drive. For more information, see *MyDrive® Insight Logic Feature Application Guide*.

7 Options and Accessories

7.1 Overview of Options and Accessories

The iC7 series also includes various options and accessories, including:

- Functional extensions
- Control panels
- Communication options
- Filters

When ordered separately, the option shipments include a printed guide with the basic installation and safety instructions.

7.2 Fieldbus Options

7.2.1 Serial Communication

The following serial communication protocols are available for iC7-Aqua:

- Modbus RTU OC7MR

For the order codes of fieldbus options, see [12.2.4 Control Board Features \(+Bxxx\)](#).

7.2.2 Ethernet Communication

The following Ethernet-based protocols are available:

- Modbus TCP OS7MT
- PROFINET RT OS7PR
- EtherCAT OS7EC
- EtherNet/IP OS7EI

When ordering a drive with PROFINET RT OS7PR, EtherCAT OS7EC, or EtherNet/IP OS7EI, it is possible to switch between all Ethernet-based protocols.

For the order codes of fieldbus options, see [12.2.4 Control Board Features \(+Bxxx\)](#).

7.3 Functional Extension Options

7.3.1 Overview

More I/O functions can be added to the frequency converters to match the specific needs of applications. Depending on the frequency converter variant, up to 4 functional extensions can be added.

Table 5: Functional Extension Options for iC7-Aqua

Option	Description
General Purpose I/O OC7C0	The General Purpose I/O option adds 3 digital inputs, 2 digital outputs, 2 analog inputs, 1 analog output, and temperature measurement support (Pt1000, Ni1000, and KTY81).
Relay Option OC7R0	The Relay option offers 3 more relays: 2 NO/NC and 1 NO rated for up to 250 V AC/2 A.
Temperature Measurement OC7T0	The Temperature Measurement option adds 5 temperature sensor inputs with compensation input. Supported sensors are Pt100, Pt1000, Ni1000, and KTY81.

7.3.2 Option Slots

iC7-Aqua frequency converters with the standard control board (B5S, B5E) have 1 option slot, identified as option slot A.

! IMPORTANT:

When ordering drives with no options or 1 option only, it is important to consider carefully if more than 1 option is needed later. Drives ordered with no options or 1 option only are shipped with the standard control board (B5S, B5E) and adding more options later is not possible.

If more than 1 functional extension option is selected when ordering the drive, the iC7-Aqua frequency converter is delivered with the advanced control board (A5S, A5E) which can support up to 4 functional extension options.

Drives with the advanced control board (A5S, A5E) can be fitted with 1–4 extra functional extension options, depending on the frame, whereas drives with the standard control board only have 1 functional extension option slot. See [Table 6](#) for more information. The following symbols are used to indicate availability:

- X indicates a standard selection.
- O indicates an optional selection.
- A dash (–) indicates that the selection is not available.

For more information on the detailed physical positions of the option slots, see [Figure 7](#).

As the connections to some option positions are established via other options, the following dependencies must be observed when designing the system:

- An option in slot B requires an option in slot A.
- An option in slot D requires an option in slot C.
- An option in slot E requires options in both slot C and slot D.

Table 6: Number of Functional Extensions per Frame

Frame		Standard control board (B5S, B5E)		Advanced control board (A5S, A5E)					
		Number of options	Slot A	Number of options	Slot A	Slot B	Slot C	Slot D	Slot E
IP20/UL Open Type	FA02a	1	O	–	–	–	–	–	–
	FA02b	–	–	2	O	O	–	–	–
	FA03a	1	O	–	–	–	–	–	–
	FA03b	–	–	3	O	O	O	–	–
	FA04a	1	O	–	–	–	–	–	–
	FA04b	–	–	3	O	O	O	–	–
	FA05a	1	O	–	–	–	–	–	–
	FA05b	–	–	4	O	O	O	O	–
	FA06–FA12	1	O	4	O	–	O	O	O
IP21/UL Type 1	FK03	1	O	3	O	–	O	O	–
	FK05–FK12	1	O	4	O	–	O	O	O
IP54/IP55/ UL Type 12	FB03	1	O	3	O	–	O	O	–
	FB05–FB12	1	O	4	O	–	O	O	O

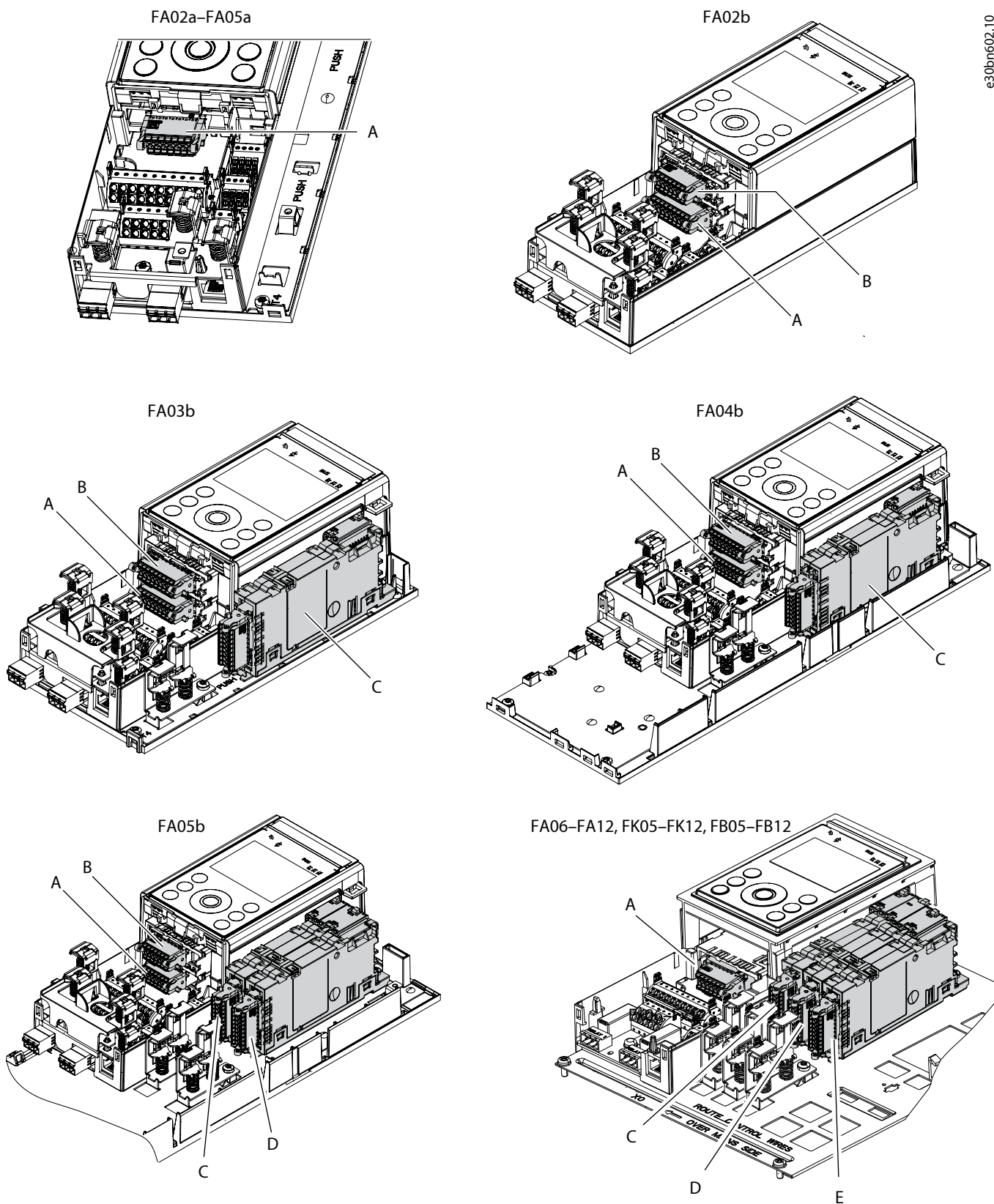

e30bn602.10

Figure 7: Option Slot Locations in iC7-Aqua Frequency Converters with the Advanced Control Board

7.4 Input and Output Filters

7.4.1 Sine-wave Filters

Sine-wave filters are installed on the output of the variable frequency drive when additional motor protection is needed, or for reduction of acoustical switching noise from the motor.

The filter provides a sinusoidal output to the motor. The sine-wave filter also reduces motor insulation stress, and is needed when the operating conditions on the motor terminals exceed motor specifications. The acoustic noise from the motor is also damped as a consequence of the sinusoidal wave condition.

An IP21/UL Type 1 kit is available to upgrade the protection rating of the IP20/UL Open Type Sine-wave Filter OF7S1 to IP21/UL Type 1. For guidance on selecting and ordering the correct filter and accessories, contact Danfoss.

When using sine-wave filters on the output, it is important to ensure that the drive switching frequency matches the filter characteristics. For iC7-Aqua drives, this is done by configuring the following parameters in parameter group **3.5 Output Filter**:

- In parameter **3.5.1 Output Filter Type**, select **Sine-wave Filter**.
- In parameter **3.5.2 Filter Capacitance**, set the capacitance in μF .
- In parameter **3.5.3 Filter Inductance**, set the inductance in mH.
- In parameter **3.5.4 Filter Inductance Resistance**, set the resistance in ohm.

For more information on parameters, see the application guide of the application software in use.

Default settings of iC7-Aqua drives match the filters offered by Danfoss.

The drive protects against overload by reducing the current and switching frequency. If the filter resonance frequency is higher than the Danfoss filter, derating of the drive output current is to be expected, usually resulting in the need to select a drive 1 size larger. The resonance frequency of the filter is calculated as $F_{\text{res}} = \frac{1}{2 \times \pi \times \sqrt{L \times C}}$.

The minimum switching frequency should be at least 3 times the resonance frequency or higher.

7.4.2 dU/dt Filters

dU/dt filters are installed on the output of the drive, when additional motor protection is needed to reduce the dU/dt voltage stress on the motor insulation caused by the voltage commutations of the drive.

Compared to sine-wave filters, dU/dt filters have a higher cut-off frequency, and lower inductance and capacitance values. With a dU/dt filter, the voltage waveform supplied to the motor is still pulse-shaped, but the current is sinusoidal.

7.4.3 Common-mode Filters

High-frequency common-mode (HF-CM) filters are used to reduce common-mode currents, typically to reduce bearing currents or to reduce high-frequency currents that circulate in the system grounding.

HF-CM filters can be used with other mitigation measures, such as dU/dt and sine-wave filters.

7.4.4 Harmonic Filters

iC7 series frequency converters have built-in harmonic filters, offering different levels of harmonic performance.

6-pulse (3N) frequency converters have built-in DC-link filters, which comply with standard requirements. If further reduction is required, external harmonic filters can be used to reduce the THDi levels to 5% or 10%. Ultra low-harmonic (3H) drives have a built-in active filter which provides a THDi level below 5%.

The Advanced Harmonic Filter OF7P2 is a passive harmonic filter with an efficient 2-stage tuned absorption circuit. The absorption circuit is specially tuned to eliminate harmonics starting with the 5th harmonic, and is designed specifically for the supply frequency. The Advanced Harmonic Filter features a compact IP20/UL Open Type enclosure that is easily integrated into existing panel space or next to the drive. The filter is intended to be mounted on a solid surface. If the filter is installed on a pedestal, or mounted on a perforated wall in a cabinet, a back plate is required.

An optional IP21/UL Type 1 kit is also available for improved protection.

For guidance on selecting and ordering the correct filter and accessories, contact Danfoss.



NOTE: Ultra low-harmonic drives (identified with code 3H in the model code) have an integrated filter and do not require an additional harmonic filter.

7.5 Kits and Accessories

7.5.1 Overview of Kits and Accessories

An extensive selection of kits, accessories, and service parts are available to support installation, flexible layout, upgradability, and continuous operation of the iC7-Aqua frequency converters.

7.5.2 Back-channel Cooling Kits

Back-channel cooling applies to frames Fx09–Fx12 and is an alternative to the traditional way of dissipating heat internally in an electrical installation cabinet or electrical room, where heat is removed by extra fans or cooling units.

In back-channel cooling, a unique back-channel duct passes cooling air over the heat sinks with minimal air passing through the electronics area. There is an IP54/UL Type 12 seal between the back-channel cooling duct and the electronics area of the iC7-Aqua frequency converter. Back-channel cooling allows 90% of the heat losses to be exhausted directly outside the enclosure and makes it possible to reduce the size of the cooling system in the panel or switch room considerably. This design improves reliability and prolongs component life by dramatically reducing internal cabinet temperatures and contamination of the electronic components.

Different back-channel cooling kits are available to redirect the airflow based on individual needs. For more information, see [10.8.8.3 Back-channel Cooling](#). For information on ordering cooling kits, see [12.4 Ordering Options and Accessories](#).

7.5.3 Pedestal Kits

Two variants of optional pedestal kits are available for the free-standing FK09–FK12 and FB09–FB12 frequency converters:

- 200 mm (7.9 in)
- 400 mm (15.8 in)

A pedestal and a cable entry plate are required for proper operation of the drive. The pedestal features a front grill to allow proper airflow for cooling the drive.

Frames FK10c/FB10c, FK11/FB11, and FK12/FB12 are delivered with a 200 mm (7.9 in) pedestal as a standard offering, since these frequency converters are always mounted as free-standing.

Available pedestal kits are listed in [12.4 Ordering Options and Accessories](#). For details on the installation, refer to the installation guides of the kits.

7.5.4 Control Panel Mounting Kits and Cables

Control panels can also be mounted apart from the drives, for example, on a wall or panel, allowing remote control and monitoring of the drives. The protection rating of the mounting kits is IP55/UL Type 21.

The control panel requires a dedicated cable. The maximum supported length of the control panel cable is 10 m (33 ft).

There are 2 types of mounting kits:

- Flush mounting kit
- Surface mounting kit

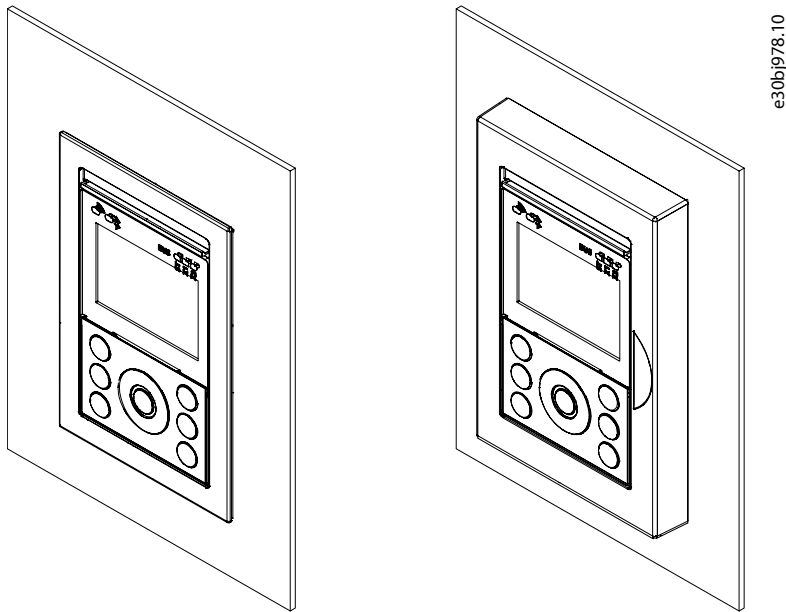

Figure 8: Control Panel Mounted in Flush Mounting Kit (Left) and Surface Mounting Kit (Right)

The available mounting kits and cable options are listed in [12.4 Ordering Options and Accessories](#). For detailed information about installing mounting kits, refer to *iC7 Series Control Panel Mounting Kits Installation Guide*.

7.5.5 Ground Bar Kits

The ground bar kit provides extra grounding points for the drives.

For details on ordering ground bar kits, see [12.4 Ordering Options and Accessories](#).

7.5.6 Cable and Wire Installation Kits

Additional cable and wire installation kits are available to facilitate wiring and to provide extra grounding points.

The multi-wire kit enables the connection of 3 wires to a single terminal in frames Fx09–Fx10. The kit includes parts for making multi-wire connections to 3 mains terminals and 3 motor terminals. The ground bar kit provides extra grounding points for FK09–FK12/FB09–FB12 frames.

For details on ordering multi-wire and ground bar kits, see [12.4 Ordering Options and Accessories](#).

8 Specifications

8.1 Overview

This chapter covers the general technical data that is required to select a frequency converter for a specific application.

8.2 Ratings

8.2.1 Overview

The rating tables provide maximum ratings of the frequency converters at 2 overload ratings. Pay attention to the supply voltage range when selecting the correct frequency converter. The overload ratings are:

- **Low Overload (LO):** Overload capability of 110% for 1 minute every 10 minutes. Typically used where a limited or no overload current is needed, and the maximum ambient temperature for 6-pulse drives is up to 40 °C (104 °F) without derating, or up to 60 °C (140 °F) with derating. For ultra low-harmonic drives, the maximum ambient temperature is up to 40 °C (104 °F) without derating, and up to 50 °C (122 °C) with derating.
- **High Overload (HO1):** Overload capability of up to 150% for 1 minute every 10 minutes. This mode supports increased current for a shorter time, for example, acceleration of heavier loads and cyclic operations with long cycle times. The maximum ambient temperature for 6-pulse drives is up to 50 °C (122 °F) without derating and up to 60 °C (140 °F) with derating. For ultra low-harmonic drives, the maximum ambient temperature is up to 45 °C (113 °F) without derating, and up to 50 °C (122 °C) with derating.

For more information on the overload modes, see [5.8.1 Load Profile Overview](#).

Typical motor power ratings are given in kW and HP at defined voltage levels for 4-pole IEC2-rated induction motors.

If operated outside nominal conditions, derating is required. For detailed information on derating, see [10.6.1 Overview](#).

The rating tables refer to frequency converters by a product code that consists of the product type, mains voltage code, and current rating code as defined in the model code positions 9–17, for example, "3N04-12A5". For more information about the model code, see [12.2.1 Overview](#).

The input current ratings (I_{LO-in} and I_{HO1-in}) are RMS values. The fundamental input current rating is typically 10% lower.

Table 7: Abbreviations Used in the Rating Tables

Abbreviation	Long form	Description
$I_{[X]-in}^{(1)}$	Input current	Rated continuous input current at the selected overload capability
$I_{[X]}^{(1)}$	Rated output current	Rated continuous output current of the selected overload capability
$I_{[X]-OL}^{(1)}$	Overload current	Overload current (1 minute) available for the selected overload capability
P_{typ}	Typical power	Typical motor power

1) In the ratings tables, [X] is replaced with the relevant overload type abbreviation:

- LO: Low Overload
- HO1: High Overload

8.2.2 Ratings for Frequency Converters with 380–480 V Supply Voltage

The ratings for the frequency converters rated for 380–480 V AC supply are given at 3 different voltage ratings:

- kW at 400 V
- kW at 415 V
- HP at 460 V

IMPORTANT:

When selecting the frequency converter, pay attention to both the supply voltage and the overload rating.

Table 8: Operational Voltage Ranges

Supply voltage	Mains voltage in model code	Unit voltage class setting	Voltage range ⁽¹⁾
380–480 V	04	Low	380–414 V
		Medium	415–440 V
		High	441–480 V

¹⁾ Voltage range is selected in parameter 2.2.1.1 Unit Voltage Class, and should be selected according to supply voltage.

8.2.3 6-pulse Frequency Converters

8.2.3.1 Current and Power Ratings 380–414 V AC

 Table 9: Current and Power Rating 380–414 V AC – Voltage Class: Low (P_{typ} in kW at 400 V)

Product code	Low overload				High overload				Frame
	I _{Lo-in} [A]	I _L [A]	I _{L-OL} [A]	P _{typ} [kW]	I _{HO1-in} [A]	I _{HO1} [A]	I _{HO1-OL} [A]	P _{typ} [kW]	
3N04-01A3	1.3	1.3	1.4	0.37	1.0	0.9	1.4	0.25	FA02, FK03, FB03
3N04-01A8	1.7	1.8	2	0.55	1.3	1.3	2.0	0.37	FA02, FK03, FB03
3N04-02A4	2.1	2.1	2.3	0.75	1.7	1.6	2.4	0.55	FA02, FK03, FB03
3N04-03A0	2.6	3	3.3	1.1	2.0	2.4	3.6	0.75	FA02, FK03, FB03
3N04-04A0	3.4	4	4.4	1.5	2.6	3	4.5	1.1	FA02, FK03, FB03
3N04-05A6	4.8	5.6	6.2	2.2	3.4	4	6	1.5	FA02, FK03, FB03
3N04-07A2	6.4	7.2	7.9	3	4.8	5.6	8.4	2.2	FA02, FK03, FB03
3N04-09A2	8.3	9.2	10.1	4	6.4	7.2	10.8	3	FA02, FK03, FB03
3N04-12A5	11.2	12.5	13.8	5.5	8.3	9.2	13.8	4	FA02, FK03, FB03
3N04-16A0	15.1	16	17.6	7.5	11.2	12.5	18.8	5.5	FA02, FK03, FB03
3N04-24A0	21.7	24	26.4	11	15	16	24	7.5	FA04, FK03, FB03
3N04-31A0	29.2	31	34.1	15	21.7	24	36	11	FA04, FK05, FB05
3N04-38A0	35.7	38	41.8	18.5	29.1	31	46.5	15	FA04, FK05, FB05
3N04-43A0	42.2	43	47.3	22	35.7	38	57	18.5	FA05, FK05, FB05
3N04-61A0	55.8	61	67	30	41.3	43	69	22	Fx06
3N04-73A0	69.7	73	80	37	56.9	61	92	30	Fx06
3N04-90A0	82	90	99	45	67.8	73	110	37	Fx07
3N04-106A	102	106	117	55	83.6	90	135	45	Fx07
3N04-147A	138	147	162	75	102	106	159	55	Fx08
3N04-170A	166	170	187	90	139	147	221	75	Fx08
3N04-206A	198	206	227	110	164	170	255	90	Fx09
3N04-245A	236	245	270	132	198	206	309	110	Fx09
3N04-302A	291	302	332	160	236	245	368	132	Fx09

Table 9: Current and Power Rating 380–414 V AC – Voltage Class: Low (P_{typ} in kW at 400 V) - (continued)

Product code	Low overload				High overload				Frame
	I_{LO-in} [A]	I_L [A]	I_{L-OL} [A]	P_{typ} [kW]	I_{HO1-in} [A]	I_{HO1} [A]	I_{HO1-OL} [A]	P_{typ} [kW]	
3N04-385A	371	385	424	200	291	302	453	160	Fx09
3N04-395A	380	395	435	200	291	302	453	160	Fx10
3N04-480A	462	480	528	250	371	385	578	200	Fx10
3N04-588A	566	588	647	315	462	480	720	250	Fx10
3N04-658A	633	658	724	355	566	588	882	315	Fx11
3N04-736A	709	736	810	400	633	658	987	355	Fx11
3N04-799A	769	799	879	450	669	695	1043	400	Fx11
3N04-893A	860	893	982	500	769	799	1199	450	Fx12
3N04-1000	963	1000	1100	560	847	880	1320	500	Fx12
3N04-1120	1078	1120	1232	630	963	1000	1500	560	Fx12
3N04-1260	1200	1260	1386	710	1059	1100	1650	630	Fx12

1) The product code consists of the product type, mains voltage, and current rating codes of the model code. For more information, see [12.2.1 Overview](#).

8.2.3.2 Current and Power Ratings 415–440 V AC

Table 10: Current and Power Rating 415–440 V AC – Voltage Class: Medium (P_{typ} in kW at 415 V)

Product code ⁽¹⁾	Low overload				High overload				Frame
	I_{LO-in} [A]	I_L [A]	I_{L-OL} [A]	P_{typ} [kW]	I_{HO1-in} [A]	I_{HO1} [A]	I_{HO1-OL} [A]	P_{typ} [kW]	
3N04-01A3	1.2	1.2	1.3	0.37	1.0	0.8	1.2	0.25	FA02, FK03, FB03
3N04-01A8	1.6	1.6	1.8	0.55	1.2	1.2	1.8	0.37	FA02, FK03, FB03
3N04-02A4	2	2.4	2.6	0.75	1.6	1.8	2.7	0.55	FA02, FK03, FB03
3N04-03A0	2.4	2.7	3	1.1	2.0	2.1	3.2	0.75	FA02, FK03, FB03
3N04-04A0	3.1	3.4	3.7	1.5	2.4	2.7	4.1	1.1	FA02, FK03, FB03
3N04-05A6	4.4	4.8	5.3	2.2	3.1	3.4	5.1	1.5	FA02, FK03, FB03
3N04-07A2	5.8	6.3	6.9	3	4.4	4.8	7.2	2.2	FA02, FK03, FB03
3N04-09A2	7.6	8.2	9	4	5.8	6.3	9.5	3	FA02, FK03, FB03
3N04-12A5	10.3	11	12.1	5.5	7.6	8.2	12.3	4	FA02, FK03, FB03
3N04-16A0	13.8	14.5	16	7.5	10.3	11	16.5	5.5	FA02, FK03, FB03
3N04-24A0	19.8	21	23.1	11	13.7	14.5	21.8	7.5	FA04, FK03, FB03
3N04-31A0	26.6	27	29.7	15	19.8	21	31.5	11	FA04, FK05, FB05
3N04-38A0	32.6	34	37.4	18.5	26.6	27	40.5	15	FA04, FK05, FB05
3N04-43A0	38.5	40	44	22	32.6	34	51	18.5	FA05, FK05, FB05
3N04-61A0	51.4	55	61	30	38.1	40	60	22	Fx06
3N04-73A0	63.7	66	73	37	52	55	83	30	Fx06
3N04-90A0	75.5	81	89	45	62.5	66	99	37	Fx07
3N04-106A	93.7	96	106	55	77	81	122	45	Fx07
3N04-147A	127	133	146	75	93.7	96	144	55	Fx08

Table 10: Current and Power Rating 415–440 V AC – Voltage Class: Medium (P_{typ} in kW at 415 V) - (continued)

Product code ⁽¹⁾	Low overload				High overload				Frame
	I_{LO-in} [A]	I_L [A]	I_{L-OL} [A]	P_{typ} [kW]	I_{HO1-in} [A]	I_{HO1} [A]	I_{HO1-OL} [A]	P_{typ} [kW]	
3N04-170A	152	156	172	90	127	133	200	75	Fx08
3N04-206A	189	196	216	110	160	166	249	90	Fx09
3N04-245A	231	240	264	132	189	196	294	110	Fx09
3N04-302A	291	302	332	160	231	240	360	132	Fx09
3N04-385A	350	364	400	200	291	302	453	160	Fx09
3N04-395A	350	364	400	200	291	302	453	160	Fx10
3N04-480A	439	456	502	250	350	364	546	200	Fx10
3N04-588A	501	520	572	315	439	456	684	250	Fx10
3N04-658A	568	590	649	355	501	520	780	315	Fx11
3N04-736A	633	658	724	400	568	590	885	355	Fx11
3N04-799A	703	730	803	450	629	653	980	400	Fx11
3N04-893A	755	784	862	500	674	700	1050	450	Fx12
3N04-1000	863	896	986	560	755	784	1176	500	Fx12
3N04-1120	990	1028	1131	630	850	896	1344	560	Fx12
3N04-1260	1107	1150	1265	710	990	1028	1542	630	Fx12

1) The product code consists of the product type, mains voltage, and current rating codes of the model code. For more information, see [12.2.1 Overview](#).

8.2.3.3 Current and Power Ratings 441–480 V AC

 Table 11: Current and Power Rating 441–480 V AC – Voltage Class: High (P_{typ} in HP at 460 V)

Product code ⁽¹⁾	Low overload				High overload				Frame
	I_{LO-in} [A]	I_L [A]	I_{L-OL} [A]	P_{typ} [HP]	I_{HO1-in} [A]	I_{HO1} [A]	I_{HO1-OL} [A]	P_{typ} [HP]	
3N04-01A3	1.2	1.2	1.3	0.5	0.9	0.8	1.2	0.33	FA02, FK03, FB03
3N04-01A8	1.5	1.6	1.8	0.75	1.1	1.2	1.8	0.5	FA02, FK03, FB03
3N04-02A4	1.9	2.1	2.3	1	1.5	1.6	2.4	0.75	FA02, FK03, FB03
3N04-03A0	2.2	2.7	3.0	1.5	1.9	2.1	3.2	1	FA02, FK03, FB03
3N04-04A0	2.9	3.4	3.7	2	2.2	2.7	4.1	1.5	FA02, FK03, FB03
3N04-05A6	4.1	4.8	5.3	3	2.9	3.4	5.1	2	FA02, FK03, FB03
3N04-07A2	5.5	6.3	6.9	4	4.1	4.8	7.2	3	FA02, FK03, FB03
3N04-09A2	7.2	8.2	9.0	5	5.5	6.3	9.5	4	FA02, FK03, FB03
3N04-12A5	9.7	11.0	12.1	7.5	7.2	8.2	12.3	5	FA02, FK03, FB03
3N04-16A0	13.0	14.5	16.0	10	9.7	11.0	16.5	7.5	FA02, FK03, FB03
3N04-24A0	18.6	21	23.1	15	12.9	14.5	21.8	10	FA04, FK03, FB03
3N04-31A0	25.1	27	29.7	20	18.6	21	31.5	15	FA04, FK05, FB05
3N04-38A0	30.7	34	37.4	25	25.1	27	40.5	20	FA04, FK05, FB05
3N04-43A0	36.3	40	44	30	30.7	34	51	25	FA05, FK05, FB05
3N04-61A0	49.4	55	61	40	36.5	40	60	30	Fx06

Table 11: Current and Power Rating 441–480 V AC – Voltage Class: High (P_{typ} in HP at 460 V) - (continued)

Product code ⁽¹⁾	Low overload				High overload				Frame
	I_{LO-in} [A]	I_L [A]	I_{L-OL} [A]	P_{typ} [HP]	I_{HO1-in} [A]	I_{HO1} [A]	I_{HO1-OL} [A]	P_{typ} [HP]	
3N04-73A0	61.2	66	73	50	49.9	55	83	40	Fx06
3N04-90A0	71.9	81	89	60	59.4	66	99	50	Fx07
3N04-106A	90.0	96	106	75	73.9	81	122	60	Fx07
3N04-147A	123	133	146	100	90.8	96	144	75	Fx08
3N04-170A	147	156	172	125	123	133	200	100	Fx08
3N04-206A	189	196	216	150	160	166	249	125	Fx09
3N04-245A	231	240	264	200	189	196	294	150	Fx09
3N04-302A	291	302	332	250	231	240	360	200	Fx09
3N04-385A	350	364	400	300	291	302	453	250	Fx09
3N04-395A	350	364	400	300	291	302	453	250	Fx10
3N04-480A	439	456	502	350	350	364	546	300	Fx10
3N04-588A	501	520	572	450	439	456	684	350	Fx10
3N04-658A	568	590	649	500	501	520	780	450	Fx11
3N04-736A	633	658	724	550	568	590	885	500	Fx11
3N04-799A	703	730	803	600	629	653	980	550	Fx11
3N04-893A	755	784	862	650	674	700	1050	550	Fx12
3N04-1000	863	896	986	750	755	784	1176	650	Fx12
3N04-1120	990	1028	1131	850	863	896	1344	750	Fx12
3N04-1260	1107	1150	1265	950	990	1028	1542	850	Fx12

1) The product code consists of the product type, mains voltage, and current rating codes of the model code. For more information, see [12.2.1 Overview](#).

8.2.4 Ultra Low-Harmonic Frequency Converters

8.2.4.1 Current and Power Ratings 380–414 V AC

Table 12: Current and Power Rating 380–414 V AC – Voltage Class: Low (P_{typ} in kW at 400 V)

Product code	Low overload				High overload				Frame
	I_{LO-in} [A]	I_L [A]	I_{L-OL} [A]	P_{typ} [kW]	I_{HO1-in} [A]	I_{HO1} [A]	I_{HO1-OL} [A]	P_{typ} [kW]	
3H04-43A0	37	43	47	22	31	38	57	18.5	Fx07
3H04-61A0	50	61	67	30	37	43	65	22	Fx07
3H04-73A0	62	73	80	37	50	61	92	30	Fx07
3H04-90A0	76	90	99	45	62	73	110	37	Fx07
3H04-106A	92	106	117	55	76	90	135	45	Fx07
3H04-147A	121	147	162	75	88	106	159	55	Fx10b
3H04-170A	145	170	187	90	121	147	221	75	Fx10b
3H04-206A	177	206	227	110	145	170	255	90	Fx10b

Table 12: Current and Power Rating 380–414 V AC – Voltage Class: Low (P_{typ} in kW at 400 V) - (continued)

Product code	Low overload				High overload				Frame
	I_{LO-in} [A]	I_L [A]	I_{L-OL} [A]	P_{typ} [kW]	I_{HO1-in} [A]	I_{HO1} [A]	I_{HO1-OL} [A]	P_{typ} [kW]	
3H04-245A	212	245	270	132	177	206	309	110	Fx10b
3H04-302A	257	302	332	160	212	245	368	132	Fx10b

1) The product code consists of the product type, mains voltage, and current rating codes of the model code. For more information, see [12.2.1 Overview](#).

8.2.4.2 Current and Power Ratings 415–440 V AC

 Table 13: Current and Power Rating 415–440 V AC – Voltage Class: Medium (P_{typ} in kW at 415 V)

Product code	Low overload				High overload				Frame
	I_{LO-in} [A]	I_L [A]	I_{L-OL} [A]	P_{typ} [kW]	I_{HO1-in} [A]	I_{HO1} [A]	I_{HO1-OL} [A]	P_{typ} [kW]	
3H04-43A0	35	40	44	22	28	34	51	18.5	Fx07
3H04-61A0	48	55	61	30	35	40	60	22	Fx07
3H04-73A0	59	66	73	37	48	55	83	30	Fx07
3H04-90A0	72	81	89	45	56	66	99	37	Fx07
3H04-106A	88	96	106	55	72	81	122	45	Fx07
3H04-147A	121	132	145	75	84	96	144	55	Fx10b
3H04-170A	145	166	183	90	121	132	198	75	Fx10b
3H04-206A	177	196	216	110	145	166	249	90	Fx10b
3H04-245A	212	240	264	132	177	206	309	110	Fx10b
3H04-302A	257	295	325	160	212	245	368	132	Fx10b

1) The product code consists of the product type, mains voltage, and current rating codes of the model code. For more information, see [12.2.1 Overview](#).

8.2.4.3 Current and Power Ratings 441–480 V AC

 Table 14: Current and Power Rating 441–480 V AC – Voltage Class: High (P_{typ} in HP at 460 V)

Product code	Low overload				High overload				Frame
	I_{LO-in} [A]	I_L [A]	I_{L-OL} [A]	P_{typ} [HP]	I_{HO1-in} [A]	I_{HO1} [A]	I_{HO1-OL} [A]	P_{typ} [HP]	
3H04-43A0	30	40	44	30	25	34	51	25	Fx07
3H04-61A0	41	55	61	40	30	40	60	30	Fx07
3H04-73A0	50	66	73	50	41	55	83	40	Fx07
3H04-90A0	61	81	89	60	50	66	99	50	Fx07
3H04-106A	75	96	106	75	61	81	106	60	Fx07
3H04-147A	101	132	145	100	75	96	144	75	Fx10b
3H04-170A	125	166	183	125	101	132	198	100	Fx10b
3H04-206A	150	196	216	150	125	166	249	125	Fx10b
3H04-245A	200	240	264	200	150	206	309	150	Fx10b
3H04-302A	251	295	325	250	200	245	368	200	Fx10b

1) The product code consists of the product type, mains voltage, and current rating codes of the model code. For more information, see [12.2.1 Overview](#).

8.3 General Technical Data

8.3.1 Grid Side

Table 15: Mains Supply

Function	Data
Supply voltage (3-phase)	<ul style="list-style-type: none"> 6-pulse frequency converters: 380–480 V AC $\pm 10\%$, -15% at reduced torque performance, depending on motor type. Ultra low-harmonic frequency converter: 380–480 V AC +10%, -15% at reduced torque performance, depending on motor type.
Grid types	TN, TT, IT, and delta (grounded and ungrounded grids) ⁽¹⁾ For details on the parameters related to grid types, refer to the application guide.
Supply frequency	45–65 Hz
Maximum temporary imbalance between mains phases	3% of rated voltage, depending on grid impedance.
True power factor (λ)	≥ 0.9 nominal at rated load and 400 V AC supply
Displacement power factor	Near unity (>0.98)
Switching on input supply from a discharged drive	6-pulse frequency converters: <ul style="list-style-type: none"> Fx02-Fx05: Maximum 2 times/minute Fx06-Fx08: Maximum 1 time/minute Fx09-Fx12: Maximum 1 time every 2 minutes Ultra low-harmonic frequency converters: <ul style="list-style-type: none"> Fx07, Fx10b: Maximum 1 time every 2 minutes
Environment	Overvoltage category III/pollution degree 2

1) For operation on IT and delta grids with ultra low-harmonic (3H) drives in frames FK07 and FB07, contact Danfoss.

8.3.2 Motor Output and Motor Data

Table 16: Motor Output (U, V, W)

Function	Data
Output voltage	0–100% of supply voltage
Output frequency	0–590 Hz ⁽¹⁾
Frequency resolution	0.001 Hz
Switching on output	Unlimited

1) Dependent on voltage, current, and control mode.

8.3.3 Torque Characteristics

The iC7 ultra low-harmonic drives have a generative non-continuous brake capability, rated up to 40% power for 1 minute.

Table 17: Torque Characteristics

Function		Data
Low overload (at LO rating)	Overload torque	110% up to 60 s every 10 minutes
	Peak torque – Break-away torque	Fx02–Fx08: 140% for 2 s Fx09–Fx12: 140% for 3 s

Table 17: Torque Characteristics - (continued)

Function		Data
High overload (at HO1 rating)	Overload torque	150% for 60 s every 10 minutes
	Peak torque – Break-away torque	Fx02–Fx08: 170% for 2 s Fx09–Fx12: 170% for 3 s
Torque rise time	VVC+ (Voltage Vector Control)	10 ms

1) Within the thermal limit

8.3.4 Control Characteristics

All control characteristics are based on a 4-pole induction motor under the following conditions:

- The drive has been set up according to motor nameplate data.
- Automatic Motor Adaptation has been conducted.
- The drive is configured for open-loop operation.
- Motor control mode has been set to VVC+.
- Nominal motor speed is not exceeded.

Table 18: Control Characteristics

Function		Data
Static speed accuracy	IM (induction motor)	20% of nominal slip ⁽¹⁾
	PM (permanent magnet motor)	< 1% of nominal speed
Dynamic speed accuracy	All motor types	< 1% second with nominal torque step

1) The accuracy depends on the motor slip:

- For a 50 Hz, 4-pole motor with a rated speed of 1460 RPM, the slip is 40 RPM. Accuracy is 8 RPM, equal to 0.6%.
- For a 50 Hz, 2-pole motor with a rated speed of 2950 RPM, the slip is 85 RPM. Accuracy is 17 RPM, equal to 0.6%.

8.3.5 Control I/O

8.3.5.1 Overview

8.3.5.1.1 Standard Control Board (B5S, B5E)

The standard configuration for drives with the standard control board (B5S, B5E) is:

- Dual-channel STO, with galvanic isolation
- STO feedback signal

The following I/Os are supported in the integrated I/O of the drive:

- 4 digital inputs
- 2 digital I/O (selected by user)
- 2 analog inputs (voltage or current)
- 1 analog output (voltage or current)
- 2 relay outputs (NC/NO)
- 24 V and 10 V reference for digital and analog I/O

The Ethernet-based standard control board (B5E) also supports 24 V external supply.

All control circuits operate at PELV potential and must be properly isolated from any external non-PELV voltage source or terminal.

8.3.5.1.2 Advanced Control Board (A5S, A5E)

The standard configuration for frequency converters with the advanced control board (A5S, A5E) is:

- 24 V external supply
- Dual-channel STO, with galvanic isolation
- STO feedback signal

With Basic I/O (+BDBA) installed, the following additional I/Os are supported:

- 4 digital inputs
- 2 digital I/O (selected by user)
- 2 analog inputs (voltage or current)
- 1 analog output (voltage or current)
- 2 relay outputs (NC/NO)
- 24 V and 10 V reference for digital and analog I/O

All control circuits operate at PELV potential and must be properly isolated from any external non-PELV voltage source or terminal.

8.3.5.2 Analog Input

Control inputs and outputs are PELV galvanically isolated from supply voltage and other high-voltage terminals, unless otherwise specified.

Table 19: Analog Input

Function	Data
Input modes	Current or Voltage ⁽¹⁾
Voltage mode	<ul style="list-style-type: none"> • Voltage range: 0 V–10 V (scalable) • Input impedance: 12 kΩ • Maximum voltage: +12 V/-12 V
Current mode	<ul style="list-style-type: none"> • Current range: 0/4-20 mA (scalable) • Input impedance: 200 Ω • Maximum current: 24 mA
Resolution	0.1% of full scale
Accuracy	1% of full scale
Bandwidth	440 Hz
Reaction time	< 1.2 ms
Temperature sensor support ⁽²⁾	Pt1000, Ni1000, KTY81, KTY82, KTY84

1) The selection is made in the software. For more information, refer to the application guide.

2) External insulation of the sensor is required to comply with PELV.

8.3.5.3 Analog Output

Control inputs and outputs are PELV galvanically isolated from supply voltage and other high-voltage terminals, unless otherwise specified.

Table 20: Analog Output

Function	Data
Output range	Current: 0/4-20 mA
	Voltage: 0–10 V

Table 20: Analog Output - (continued)

Function	Data
Load resistor to GND	Current output: < 500 Ω
	Voltage output: > 2 kΩ
Resolution	0.1% of full scale
Accuracy	1% of full scale
Bandwidth	440 Hz
Reaction time	< 1 ms

8.3.5.4 Digital and Pulse Input

Control inputs and outputs are PELV galvanically isolated from supply voltage and other high-voltage terminals, unless otherwise specified.

Table 21: Digital and Pulse Input

Function	Data	
Digital input	Logic	Selectable PNP or NPN
	Voltage levels	0/24 V
	PNP	<ul style="list-style-type: none"> • 0: <5 V DC • 1: >11 V DC
	NPN	<ul style="list-style-type: none"> • 0: >19 V DC • 1: < 13 V DC
	Maximum allowed voltage	30 V DC
	Input resistance	4 kΩ
Thermistor input	PTC ⁽¹⁾	1.5–4 kΩ
Pulse input	Pulse frequency range	0–110 kHz
	Minimum duty cycle	40%

1) External insulation of the sensor is required to comply with PELV.

8.3.5.5 Digital and Pulse Output

Control inputs and outputs are PELV galvanically isolated from supply voltage and other high-voltage terminals, unless otherwise specified.

Table 22: Digital and Pulse Output (24 V)

Function	Data
Voltage level	0/24 V
Maximum output load (sink/source)	50 mA
Frequency range - Pulse output	1–100 kHz
Maximum load	1 kΩ
Maximum capacitive load at maximum frequency	10 nF
Pulse output accuracy	0.1% of full scale
Resolution of pulse output	>12 bit

8.3.5.6 Relay Output

Relays provide PELV isolation to supply voltage, other high-voltage terminals and low-voltage control.

Table 23: Relay Output

Function	Data
Relay configuration	SPDT (NO/NC)
Maximum terminal load (AC-1): Resistive load	250 V AC, 2 A
Maximum terminal load (AC-15): Inductive load @ $\cos\phi=0.4$	250 V AC, 0.2 A
Maximum terminal load (DC-1): Resistive load	80 V DC, 2 A
Maximum terminal load (DC-13): Inductive load	24 V DC, 0.1 A
Minimum load	<ul style="list-style-type: none"> 24 V DC, 10 mA 24 V AC, 20 mA
Rated number of cycles (@2 A resistive load)	400.000 switchings

8.3.5.7 Auxiliary Voltages

Drives can have multiple power sources, which must be considered when operating the drive. For information on the necessary safety precautions, refer to the product-specific installation, safety, and operating guides.

Auxiliary voltage outputs are used as a reference for analog and digital inputs. All voltage outputs must be Class 2.

If the mains supply is disconnected from a drive with an Ethernet-based control board, the auxiliary 24 V input is also used as a backup source for the control and fieldbus connections.

Table 24: Auxiliary Voltages

Function	Data	
24 V external supply (X61) ¹⁾	Input voltage	24 V \pm 10%
	Maximum input current	2 A
24 V output, functional safety (X31, X32)	Output voltage	24 V \pm 15%
	Maximum load	100 mA
10 V output	Output voltage	10 V \pm 2%
	Maximum load	10 mA
24 V output	Output voltage	24 V \pm 20%
	Maximum load	150 mA

1) Applies to drives with an Ethernet-based control board (A5E, B5E) or the serial control board A5S.

8.3.6 Functional Safety

8.3.6.1 Functional Safety Standards and Performance

All safety functions in the iC7 frequency converters meet the requirements of the standards listed in this chapter.

Table 25: Functional Safety Standards and Performance

Directive or Standard		Version
European Union directives	Machinery Directive (2006/42/EC)	EN ISO 13849-1:2015, EN ISO 13849-2:2012
		EN IEC 61800-5-2:2007
	EMC Directive (2014/30/EU)	EN IEC 61800-3:2018 – second environment
		EN IEC 61326-3-1:2017
Low Voltage Directive (2014/35/EU)	EN IEC 61800-5-1:2017	
Safety standards	Safety of Machinery	EN ISO 13849-1:2015, IEC 60204-1:2018
	Functional Safety	IEC 61508-1:2010, IEC 61508-2:2010, IEC61508-3:2010, EN IEC 61800-5-2:2017
Safety function		EN IEC 61800-5-2:2017 Safe Torque Off (STO), Safe Stop 1 (SS1-t)
		IEC 60204-1:2018 Stop Category 0, Stop Category 1
Safety performance	IEC 61508:2010	
	Safety Integrity Level	SIL 3
	Hardware Fault Tolerance (HFT)	1
	Subsystem Classification	Type B
	Average probability of dangerous failures on demand (PFDavg) ⁽¹⁾⁽²⁾	$< 1.5 \cdot 10^{-4}$
	Average frequency of dangerous failures per hour (1/h) (PFH) ⁽¹⁾⁽²⁾	$< 7.5 \cdot 10^{-9}$
	Proof Test Interval (T1)	20 years
	Mission Time (TM)	20 years
	ISO 13849-1:2015	
	Category	Cat 3
	Performance Level (PL)	PL e
	Mean time to dangerous failure (MTTFd)	High (> 100 years)
	Diagnostic Coverage (DCavg)	>90%
	Reaction time	Fault Reaction Time (FRT)
Response time	Response time (from input to safe state)	< 30 ms ⁽³⁾
Mode of operation		High demand, Low demand

1) At sea level.

2) Proof tests can only be performed at Danfoss facilities when the drive is refurbished.

3) Input to output response time with shielded cables. Otherwise, a maximum of 20 ms might be added to this value under worst case EMC conditions.

8.3.6.2 Technical Data

Control input and outputs are galvanically isolated from supply voltage (PELV) and other high-voltage terminals, unless otherwise specified.

Table 26: 24 V Digital Input for STO Input

Function	Data
Input type	Single-ended/floating
Logic	PNP
Voltage level	0–24 V DC
Voltage level, logic 0 PNP	<5 V
Voltage level, logic 1 PNP	>11 V
Maximum voltage on input @ functional	30 V
Maximum voltage on input @ safe state	60 V
Input current	8 mA > I _c > 5 mA @ 24 V
Equivalent input resistance	3 kΩ < R _i < 4.7 kΩ @ 24 V
Isolation	Functional
Reverse polarity protection	Yes
Maximum input current off-state	0.1 mA

Table 27: 24 V Digital Outputs for STO Feedback

Function	Data
Output type	Sink/source
Voltage rating	24 V DC open collector/60 V maximum
Current rating	50 mA
Isolation	Functional
Overload protection	Yes
Reverse polarity protection	Yes
ON state voltage	>17.4 V
Off state leakage current	0.1 mA

Table 28: Auxiliary Voltages

Function	Data	
24 V output, functional safety (X31, X32)	Output voltage	24 V ±15%
	Maximum load	100 mA

8.3.7 Real-time Clock

Table 29: Real-time Clock Features in iC7-Aqua Drives with the B5S, A5S, or A5E Control Board

Function	Data	
Real-time clock	Time format	<ul style="list-style-type: none"> Year, month, day, weekday, hours, minutes, seconds Leap year correction
	Precision	Better than 30 ppm/2.6 s/day
	Battery backup	Exchangeable coin-cell battery. <ul style="list-style-type: none"> Panasonic CR2032 (3 V, 85°C) for Control Board B5S⁽¹⁾ Panasonic BR1632 (3 V, 125°C) for Control Board A5S and A5E⁽²⁾
	Battery monitor	Yes
	Expected battery life	Drives with the standard control board B5S: > 15 years, depending on temperature Drives with the advanced control board A5E or A5S: > 9 years, depending on temperature

1) Replace battery with Panasonic type CR2032. Only qualified personnel can exchange the battery.

2) Replace battery with Panasonic type BR1632/DBN. Only qualified personnel can exchange the battery.

8.3.8 Ambient Conditions

8.3.8.1 Overview

The frequency converter is designed for installation and use in weather-protected environments. The available protection ratings are:

- IP20/UL Open Type (frames FA02–FA12)
- IP21/UL Type 1 (frames FK03, FK05–FK12)
- IP54/UL Type 12 (frames FB09–FB12)
- IP55/UL Type 12 (frames FB03, FB05–FB08)

Conditions are given for:

- Transport (see [8.3.8.2 Ambient Conditions during Transport](#)).
- Storage (see [8.3.8.3 Ambient Conditions during Storage](#)).
- Operation (see [8.3.8.4 Ambient Conditions during Operation](#)).

8.3.8.2 Ambient Conditions during Transport

The environments used as reference for the design criteria are described in the standards IEC 60721-3-1:2019, IEC 60721-3-2:2018 and, IEC 60721-3-3:2019, unless otherwise specified. References based on IEC/EN 61800-2 are given in parentheses.

Table 30: Ambient Conditions during Transport

Function	Data
Ambient temperature	-40...+70 °C (-40...+158 °F)
Climatic condition	2K11 (2K2), maximum 95% non-condensing
Chemically active substances	2C2 (2C2)

Table 30: Ambient Conditions during Transport - (continued)

Function	Data
Solid particles (nonconductive)	2S5 (2S5)
Vibration	2M5 (2M5)
Shock	2M5 (2M5)
	When installed on equipment: 2M4 (2M4)
Biological ambient	2B1 (2B1)

8.3.8.3 Ambient Conditions during Storage

The environments used as reference for the design criteria are described in the standards IEC 60721-3-1:2019, IEC 60721-3-2:2018 and, IEC 60721-3-3:2019, unless otherwise specified. References based on IEC/EN 61800-2 are given in parentheses.

Table 31: Ambient Conditions during Storage

Function	Data
Ambient temperature	-40...+55 °C (-40...+131 °F), 70 °C (158 °F) up to 4 months
Climatic condition	1K21 (1K4), maximum 95% non-condensing
Chemically active substances	1C2 (1C2)
Solid particles (non-conductive)	1S12 (1S12)
Vibration	1M11 (1M11)
Shock	1M11 (1M11)
Biological ambient	1B2 (1B12)

8.3.8.4 Ambient Conditions during Operation

The environments used as reference for the design criteria are described in the standards IEC 60721-3-1:2019, IEC 60721-3-2:2018 and, IEC 60721-3-3:2019, unless otherwise specified. References based on IEC/EN 61800-2 are given in parentheses.

Table 32: Ambient Conditions during Operation

Function	Data
Ambient temperature	<ul style="list-style-type: none"> • Low overload: -30...+40 °C (-22...+104 °F) • High overload: <ul style="list-style-type: none"> ◆ 6-pulse (3N) drives: -30...+50 °C (-22...+122 °F) ◆ Ultra low-harmonic (3H) drives: -30...+45 °C (-22...+113 °F)⁽¹⁾
	With derating: <ul style="list-style-type: none"> • 6-pulse frequency converters: -30...+60 °C (-22...+140 °F) • Ultra low-harmonic frequency converters: -30...+50 °C (-22...+122 °F)
Climatic condition	3K22 (3K3), maximum 95% non-condensing ⁽²⁾
Chemically active substances	<ul style="list-style-type: none"> • C3 (P1) Medium – non-coated drives (3C2) • C4 (P2) High – coated (3C3) <ul style="list-style-type: none"> ◆ IP20/UL Open Type installed in cabinet ◆ IP21/UL Type 1 ◆ IP54/IP55/UL Type 12
Solid particles (nonconductive)	3S6 (3S2)

Table 32: Ambient Conditions during Operation - (continued)

Function	Data
Vibration	3M12 (3M4)
Shock	3M12 (3M4)
Biological ambient	3B1 (3B1)
Maximum altitude above sea level	Without derating: 1000 m (3300 ft)
	With derating: <ul style="list-style-type: none"> • TN/TT/IT grids: 4400 m (14400 ft) • Delta grids: 2000 m (6600 ft)

1) UL approval for Fx10b is up to 40 °C (104 °F) without derating.

2) Ensure a maximum rate of change of temperature 0.1°C/minute to avoid condensation.

8.3.9 Discharge Times

Discharge time is the time required to discharge the DC-link capacitors of the drive after all external power sources have been disconnected.

Frame	Minimum waiting time (min)
Fx02–Fx03	5
Fx04–Fx08	15
Fx09–Fx10	20
Fx11–Fx12	40

8.4 Fuses and Circuit Breakers

8.4.1 Overview

For proper protection of the installation cable and the drive, fuses and/or circuit breakers must be used. Overcurrent protection devices must be installed as close to the drive as possible. If a short circuit occurs, fuses and circuit breakers protect the power cable and limit the damage to the frequency converter and components connected to the frequency converter.

The recommendations for fuses and circuit breakers must be followed to comply with relevant regulations. If recommendations are not followed, and problems occur, warranty may be affected.

For further details, contact Danfoss.

8.4.2 6-pulse Frequency Converters

8.4.2.1 IEC Compliant Fuses

To comply with IEC requirements, using gG and aR fuses is recommended, depending on drive rating. The fuse rating must not exceed the verification rating.

For installations specifying the use of aR-type fuses, an additional overcurrent protective device must be installed in series to provide complete branch-circuit protection.

Table 33: Recommended IEC Compliant Fuses for IP20 Frames FA02–FA08 (Voltage Range 380–480 V)

Product code ⁽¹⁾	Frame	Power [kW]	Recommended [A]	Tested with [A]	Fuse type	Minimum SCCR [kA]	Maximum SCCR [kA]
3N04-01A3	FA02	0.37	10	16	gG	1	100
3N04-01A8	FA02	0.55	10	16	gG	1	100

Table 33: Recommended IEC Compliant Fuses for IP20 Frames FA02–FA08 (Voltage Range 380–480 V) - (continued)

Product code ⁽¹⁾	Frame	Power [kW]	Recommended [A]	Tested with [A]	Fuse type	Minimum SCCR [kA]	Maximum SCCR [kA]
3N04-02A4	FA02	0.75	10	16	gG	1	100
3N04-03A0	FA02	1.1	10	16	gG	1	100
3N04-04A0	FA02	1.5	10	16	gG	1	100
3N04-05A6	FA02	2.2	10	16	gG	1	100
3N04-07A2	FA02	3	10	16	gG	1	100
3N04-09A2	FA02	4	16	20	gG	1	100
3N04-12A5	FA02	5.5	20	20	gG	1	100
3N04-16A0	FA02	7.5	25	25	gG	1	100
3N04-24A0	FA04	11	40	50	gG	1	100
3N04-31A0	FA04	15	50	50	gG	3	100
3N04-38A0	FA04	18.5	50	63	gG	3	100
3N04-43A0	FA05	22	63	63	gG	3	100
3N04-61A0	FA06	30	80	100	gG	3	100
3N04-73A0	FA06	37	100	100	gG	5	100
3N04-90A0	FA07	45	125	160	gG	5	100
3N04-106A	FA07	55	160	160	gG	5	100
3N04-147A	FA08	75	200	224	gG	10	100
3N04-170A	FA08	90	224	224	gG	10	100

1) The product code consists of the product type, mains voltage, and current rating codes of the model code. For more information, see [12.2.1 Overview](#).

Table 34: Recommended IEC Compliant Fuses for IP21 Frames FK06–FK08 and IP55/IP54 Frames FB06–FB08 (Voltage Range 380–480 V)

Product code ⁽¹⁾	Frame	Power [kW]	Recommended [A]	Tested with [A]	Fuse type	Minimum SCCR [kA]	Maximum SCCR [kA]
3N04-61A0	FK06/FB06	30	80	100	gG	3	100
3N04-73A0	FK06/FB06	37	100	100	gG	5	100
3N04-90A0	FK07/FB07	45	125	160	gG	5	100
3N04-106A	FK07/FB07	55	160	160	gG	5	100
3N04-147A	FK08/FB08	75	200	224	gG	10	100
3N04-170A	FK08/FB08	90	224	224	gG	10	100

1) The product code consists of the product type, mains voltage, and current rating codes of the model code. For more information, see [12.2.1 Overview](#).

Table 35: Recommended IEC Compliant Fuses for Frames Fx09–Fx12 (Voltage Range 380–480 V)

Product code ⁽¹⁾	Frame	Power [kW] (LO/HO)	Recommended [A]	Tested with [A]	Fuse type	Minimum SCCR [kA]	Maximum SCCR [kA]
3N04-206A	Fx09	110/90	315	400	aR	10	100
3N04-245A	Fx09	132/110	350		aR	10	100
3N04-302A	Fx09	160/132	400		aR	10	100

Table 35: Recommended IEC Compliant Fuses for Frames Fx09–Fx12 (Voltage Range 380–480 V) - (continued)

Product code ⁽¹⁾	Frame	Power [kW] (LO/HO)	Recommended [A]	Tested with [A]	Fuse type	Minimum SCCR [kA]	Maximum SCCR [kA]
3N04-385A	Fx09	200/160	475	475	aR	18	100
3N04-395A	Fx10	200/160	630	800	aR	18	100
3N04-480A	Fx10	250/200	630		aR	18	100
3N04-588A	Fx10	315/250	800		aR	18	100
3N04-658A	Fx11	355/315	1000	1250	aR	30	100
3N04-736A	Fx11	400/355			aR	30	100
3N04-799A	Fx11	450/400	1250	1250	aR	30	100
3N04-893A	Fx12	500/450			aR	30	100
3N04-1000	Fx12	560/500			aR	30	100
3N04-1120	Fx12	630/560	1800	1800	aR	42	100
3N04-1260	Fx12	710/630			aR	42	100

1) The product code consists of the product type, mains voltage, and current rating codes of the model code. For more information, see [12.2.1 Overview](#).

8.4.2.2 UL Compliant Fuses

Danfoss products have been designed according to NEC 2023, and it is mandatory to use fuses or circuit breakers with the drives. Danfoss recommends using a selection of the fuses listed in the following tables.

The fuse specifications apply only to external fuses.

Frames FK06–FK08 may be delivered with internal fuses and a disconnect (+AJFX, AJFD). The disconnect reduces the maximum prospective short-circuit rating to 65 kA. If the internal fuses need to be replaced, contact an authorized service partner.

Table 36: Recommended Maximum Fuses for UL Open Type Frames FA02–FA08 Installed in Cabinets (Voltage Range 3 x 380–480 V)

Product code ⁽¹⁾	Frame	Power [kW]	Recommended [A]	Tested with [A]	Fuse type	Minimum external cabinet volume [l (cu ft.)]	Minimum SCCR [kA]	Maximum SCCR [kA]
3N04-01A3	FA02	0.37	3	15	RK5	52 (1.8)	5.0	100
3N04-01A8	FA02	0.55	6	15	RK5	52 (1.8)	5.0	100
3N04-02A4	FA02	0.75	6	15	RK5	52 (1.8)	5.0	100
3N04-03A0	FA02	1.1	10	15	RK5	52 (1.8)	5.0	100
3N04-04A0	FA02	1.5	10	15	RK5	52 (1.8)	5.0	100
3N04-05A6	FA02	2.2	10	15	RK5	52 (1.8)	5.0	100
3N04-07A2	FA02	3	15	15	RK5	52 (1.8)	5.0	100
3N04-09A2	FA02	4	15	20	RK5	52 (1.8)	5.0	100
3N04-12A5	FA02	5.5	20	20	RK5	52 (1.8)	5.0	100
3N04-16A0	FA02	7.5	25	25	RK5	52 (1.8)	5.0	100
3N04-24A0	FA04	11	40	50	RK5	96 (3.4)	5.0	100
3N04-31A0	FA04	15	50	50	RK5	96 (3.4)	5.0	100
3N04-38A0	FA04	18.5	60	60	RK5	96 (3.4)	5.0	100

Table 36: Recommended Maximum Fuses for UL Open Type Frames FA02–FA08 Installed in Cabinets (Voltage Range 3 x 380–480 V) - (continued)

Product code ⁽¹⁾	Frame	Power [kW]	Recommended [A]	Tested with [A]	Fuse type	Minimum external cabinet volume [l (cu ft.)]	Minimum SCCR [kA]	Maximum SCCR [kA]
3N04-43A0	FA05	22	70	60	RK5	96 (3.4)	5.0	100
3N04-61A0	FA06	30	80	125	T/J	192 (6.8)	5.0	100
3N04-73A0	FA06	37	100	125	T/J	192 (6.8)	5.0	100
3N04-90A0	FA07	45	125	200	T/J	240 (8.5)	10.0	100
3N04-106A	FA07	55	150	200	T/J	240 (8.5)	10.0	100
3N04-147A	FA08	75	200	225	T/J	288 (10.2)	10.0	100
3N04-170A	FA08	90	225	225	T/J	288 (10.2)	10.0	100

1) The product code consists of the product type, mains voltage, and current rating codes of the model code. For more information, see [12.2.1 Overview](#).

Table 37: Recommended Maximum Fuses for UL Type 1 Frames FK06–FK08 and UL Type 12 Frames FB06–FB08 (Voltage Range 3 x 380–480 V)

Product code ⁽¹⁾	Frame	Power [kW]	Recommended [A]	Tested with [A]	Fuse type	Minimum SCCR [kA]	Maximum SCCR [kA]
3N04-61A0	FK06/FB06	30	80	125	T/J	5.0	100
3N04-73A0	FK06/FB06	37	100	125	T/J	5.0	100
3N04-90A0	FK07/FB07	45	125	200	T/J	10.0	100
3N04-106A	FK07/FB07	55	150	200	T/J	10.0	100
3N04-147A	FK08/FB08	75	200	225	T/J	10.0	100
3N04-170A	FK08/FB08	90	225	225	T/J	10.0	100

1) The product code consists of the product type, mains voltage, and current rating codes of the model code. For more information, see [12.2.1 Overview](#).

Table 38: Recommended UL Compliant Fuses for Fx09-Fx12 Frames

Product code ⁽¹⁾	Frame	Power [kW] (LO/HO)	Recommended Fuse rating [A]	Tested with [A]	Fuse type	Bussmann PN	Maximum SCCR [kA]
3N04-206A	Fx09	110/90	315	400	Semiconductor fuse	170M2619	100
3N04-245A	Fx09	132/110	350		Semiconductor fuse	170M2620	100
3N04-302A	Fx09	160/132	400		Semiconductor fuse	170M2621	100
3N04-385A	Fx09	200/160	475	475	Semiconductor fuse	170M9007	100
3N04-395A	Fx10	200/160	550	800	Semiconductor fuse	170M4015	100
3N04-480A	Fx10	250/200	630		Semiconductor fuse	170M4016	100
3N04-588A	Fx10	315/250	800		Semiconductor fuse	170M4018	100
3N04-658A	Fx11	355/315	1000	1250	Semiconductor fuse	170M6014	100
3N04-736A	Fx11	400/355			Semiconductor fuse		100

Table 38: Recommended UL Compliant Fuses for Fx09-Fx12 Frames - (continued)

Product code ⁽¹⁾	Frame	Power [kW] (LO/HO)	Recommended Fuse rating [A]	Tested with [A]	Fuse type	Bussmann PN	Maximum SCCR [kA]
3N04-799A	Fx11	450/400	1250	1250	Semiconductor fuse	170M7309	100
3N04-893A	Fx12	500/450			Semiconductor fuse		100
3N04-1000	Fx12	560/500			Semiconductor fuse		100
3N04-1120	Fx12	630/560	1800	1800	Semiconductor fuse	170M7340	100
3N04-1260	Fx12	710/630			Semiconductor fuse		100

1) The product code consists of the product type, mains voltage, and current rating codes of the model code. For more information, see [12.2.1 Overview](#).

NOTICE

DISCONNECT SWITCH SCCR REQUIREMENTS

All units ordered and supplied with a factory-installed disconnect switch (+AJXD, +AJFD) require a Class fuse for branch circuit protection to meet the 100 kA SCCR for the drive.

If a circuit breaker is used, the SCCR rating is less than 100 kA.

- The product code of the drive determines the specific Class fuse. The product code is stated on the product label.
- For more details on the fuses and circuit breakers, see [Table 39](#).

Table 39: Disconnect Switch SCCR Requirements for Fx09-Fx12 Frames (380-480 V Input Voltage)

Product code ⁽¹⁾	Short circuit rating (kA)	Required protection
3N04-206A	30	Circuit breaker
	100	Class J fuse, 600A
3N04-245A	30	Circuit breaker
	100	Class J fuse, 600A
3N04-302A	30	Circuit breaker
	100	Class J fuse, 600A
3N04-395A	30	Circuit breaker
	100	Class J, T, L fuse, 800A
3N04-480A	30	Circuit breaker
	100	Class J, T, L fuse, 800A
3N04-588A	30	Circuit breaker
	100	Class J, T, L fuse, 800A
3N04-658A	42	Circuit breaker
	100	Class L fuse, 800A
3N04-736A	42	Circuit breaker
	100	Class L fuse, 800A
3N04-799A	42	Circuit breaker
	100	Class L fuse, 800A

Table 39: Disconnect Switch SCCR Requirements for Fx09–Fx12 Frames (380–480 V Input Voltage) - (continued)

Product code ⁽¹⁾	Short circuit rating (kA)	Required protection
3N04-893A	42	Circuit breaker
	100	Class L fuse, 1200A
3N04-1000	42	Circuit breaker
	100	Class L fuse, 1200A
3N04-1120	42	Circuit breaker
	100	Class L fuse, 1200A
3N04-1260	42	Circuit breaker
	100	Class L fuse, 1200A

1) The product code consists of the product type, mains voltage, and current rating codes of the model code. For more information, see [12.2.1 Overview](#).

8.4.2.3 IEC Compliant Circuit Breakers

Recommended circuit breakers are listed in [Table 40](#). If the circuit breaker limits the energy into the drive to a level equal to or lower than the recommended types, other types of circuit breakers can be used.

Table 40: Recommended Circuit Breakers for IEC Compliant Installation in IP20 Frames

Product code ⁽¹⁾	Manufacturer and model	Voltage range, limited by breaker	Minimum SCCR	Recommended maximum SCCR (Ics) ⁽²⁾	Verified SCCR (Icu) ⁽³⁾
3N04-01A3; 3N04-01A8; 3N04-02A4; 3N04-03A0; 3N04-04A0; 3N04-05A6; 3N04-07A2	ABB S203P-C16	380–400	1	12.5	25
	ABB S203M-C16	380–400	1	11.2	15
	ABB MS165-16 ⁽⁴⁾	380–440	1	65	65
3N04-09A2; 3N04-12A5	ABB S203P-C20	380–400	1	12.5	25
	ABB S203M-C20	380–400	1	11.2	15
	ABB MS165-20 ⁽⁴⁾	380–440	1	65	65
3N04-16A0	ABB S203P-C25	380–400	1	12.5	25
	ABB S203M-C25	380–400	1	11.2	15
	ABB MS165-25	380–440	1	50	50
3N04-24A0	ABB S203P-C50	380–400	3	11.2	15
	ABB S203M-C40	380–400	3	11.2	15
	ABB MS165-32 ⁽⁵⁾	380–440	3	50	50
3N04-31A0	ABB S203P-C50	380–400	3	11.2	15
	ABB S203M-C50	380–400	3	11.2	15
	ABB MS165-42 ⁽⁵⁾	380–440	3	50	50

Table 40: Recommended Circuit Breakers for IEC Compliant Installation in IP20 Frames - (continued)

Product code ⁽¹⁾	Manufacturer and model	Voltage range, limited by breaker	Minimum SCCR	Recommended maximum SCCR (Ics) ⁽²⁾	Verified SCCR (Icu) ⁽³⁾
3N04-38A0; 3N04-43A0	ABB S203P-C63	380–400	3	11.2	15
	ABB S203M-C63	380–400	3	11.2	15
	ABB MS165-54 ⁽⁵⁾	380–440	3	30	45

1) The product code consists of the product type, mains voltage, and current rating codes of the model code. For more information, see [12.2.1 Overview](#).

2) Ics (Rated Service Short-Circuit Breaking Capacity) ensures that the branch circuit protection can still function after fault interruptions, supporting system continuity.

3) Icu (Rated Ultimate Short-Circuit Breaking Capacity) guarantees safety at maximum fault current, even if the branch circuit protection is damaged afterward.

4) Verified at a lower level than rated.

5) Products with circuit breaker models MS165-32, MS165-42, and MS165-54 must be mounted in a cabinet.

8.4.2.4 UL Compliant Circuit Breakers and Combination Motor Controllers

In UL-compliant installations, the circuit breaker must be used with a fuse in series, and a combination motor controller (CMC) is suitable as branch circuit protection by itself. The short-circuit current rating (SCCR) must comply with the rating given in [Table 41](#).

Table 41: Recommended Circuit Breakers for UL Compliant Installation in IP20/UL Open Type Frames

Product code ⁽¹⁾	Frame	Manufacturer and model	Maximum trip level [A]	Ratings	Maximum SCCR [kA]	Minimum external cabinet volume [l (cu ft.)]
3N04-01A3	FA02	ABB MS165-16	16	CMC Type E (480Y/277 V AC)	65	52 (1.8)
3N04-01A8		ABB MS165-16	16	CMC Type E (480Y/277 V AC)	65	52 (1.8)
3N04-02A4		ABB MS165-16	16	CMC Type E (480Y/277 V AC)	65	52 (1.8)
3N04-03A0		ABB MS165-16	16	CMC Type E (480Y/277 V AC)	65	52 (1.8)
3N04-04A0		ABB MS165-16	16	CMC Type E (480Y/277 V AC)	65	52 (1.8)
3N04-05A6		ABB MS165-16	16	CMC Type E (480Y/277 V AC)	65	52 (1.8)
3N04-07A2		ABB MS165-16	16	CMC Type E (480Y/277 V AC)	65	52 (1.8)
3N04-09A2		ABB MS165-20	20	CMC Type E (480Y/277 V AC)	65	52 (1.8)
3N04-12A5		ABB MS165-20	20	CMC Type E (480Y/277 V AC)	65	52 (1.8)
3N04-16A0		ABB MS165-25	25	CMC Type E (480Y/277 V AC)	65	52 (1.8)
3N04-24A0		FA04	ABB MS165-42	42	CMC Type E (480Y/277 V AC)	65
3N04-31A0	ABB MS165-42		42	CMC Type E (480Y/277 V AC)	65	96 (3.4)
3N04-38A0	ABB MS165-54		54	CMC Type E (480Y/277 V AC)	65	96 (3.4)
3N04-43A0	FA05	ABB MS165-54	54	CMC Type E (480Y/277 V AC)	65	96 (3.4)

1) The product code consists of the product type, mains voltage, and current rating codes of the model code. For more information, see [12.2.1 Overview](#).

8.4.3 Ultra Low-Harmonic Frequency Converters

8.4.3.1 IEC Compliant Fuses

To comply with IEC requirements, using gG and aR fuses is recommended, depending on drive rating. The fuse rating must not exceed the verification rating.

For installations specifying the use of aR-type fuses, an additional overcurrent protective device must be installed in series to provide complete branch-circuit protection.

Table 42: Recommended IEC Compliant Fuses

Product code ⁽¹⁾	Frame	Power (kW)	Recommended fuse	Tested with	Minimum SCCR [kA]	Maximum SCCR [kA]
3H04-43A0	FB07	22	63 A, aR	160 A, aR	3	100
3H04-61A0	FB07	30	125 A, aR	160 A, aR	3	100
3H04-73A0	FB07	37	125 A, aR	160 A, aR	5	100
3H04-90A0	FB07	45	160 A, aR	160 A, aR	10	100
3H04-106A	FB07	55	160 A, aR	160 A, aR	10	100
3H04-147A	Fx10b	75	250 A, aR	400 A, aR	10	100
3H04-170A	Fx10b	90	315 A, aR	400 A, aR	10	100
3H04-206A	Fx10b	110	315 A, aR	400 A, aR	10	100
3H04-245A	Fx10b	132	350 A, aR	400 A, aR	18	100
3H04-302A	Fx10b	160	400 A, aR	400 A, aR	18	100

1) The product code consists of the product type, mains voltage, and current rating codes of the model code. For more information, see [12.2.1 Overview](#).

8.4.3.2 UL Compliant Fuses

Danfoss products have been designed according to NEC 2023, and it is mandatory to use fuses or circuit breakers with the drives. Danfoss recommends using a selection of the fuses listed in the following tables.

The fuse specifications apply only to external fuses.

Frames FK06–FK08/FB06–FB08 may be delivered with internal fuses and a disconnect (+AJFX, +AJFD). The disconnect reduces the maximum prospective short-circuit rating to 65 kA. If the internal fuses need to be replaced, contact an authorized service partner.

Table 43: Recommended UL Compliant Fuses

Product code ⁽¹⁾	Frame	Tested with [A]	Bussmann PN	Maximum SCCR [kA]
3H04-43A0	Fx07	170M1319	170M1315	100
3H04-61A0			170M1318	
3H04-73A0			170M1318	
3H04-90A0			170M1319	
3H04-106A			170M1319	
3H04-147A	Fx10b	170M2621	170M1321	
3H04-170A			170M2619	
3H04-206A			170M2619	
3H04-245A			170M2620	
3H04-302A			170M2621	

1) The product code consists of the product type, mains voltage, and current rating code of the model code. For more information, see [12.2.1 Overview](#).

8.4.4 Protection of DC Interface

The DC interface of the frequency converter is used in some configurations only, for example, load sharing between a larger and a smaller drive.

The protection measures vary based on the setup. For further information and guidance on use, contact Danfoss.

8.5 Dimensioning of Power Cables

To ensure proper operation, observe the cross-section dimensions, stripping length, and tightening torques.

The dimensions apply to both solid and stranded cables. Unless otherwise specified, the specifications apply to IP20/UL Open Type, IP21/UL Type 1, and IP54/IP55/UL Type 12 frames. Drives are designed for use of 70 °C (158 °F) rated copper cables for frames up to Fx07. For Fx08–Fx12, 90 °C (194 °F) rated copper cable is recommended. If nothing else is stated, the ambient temperature of the drive matches the cable rating. Aluminum cables can be used from 35 mm² onwards. Proper connections must be secured by removing the oxide layer and applying joint compound.

NOTICE

Using a cable with the maximum allowed cross-section requires more effort during the installation.

Table 44: Power Cable Sizing for IP20/UL Open Type Frames FA02–FA12

Frame	Terminal	Cross-section [mm ² (AWG)]	Torque [Nm (in-lb)]	Strip-ping length [mm (in)]	Connector type	Screw/Lug type
FA02	All	0.2–6 (24–10)	0.7 (6.2) ⁽¹⁾	10 (0.4)	Pluggable terminal	SL1/PZ1
FA04	All	6–16 (10–6)	1.2–1.5 (17)	15 (0.6)	Pluggable terminal	SL1/T15
FA05	All	10–25 (8–4)	2.0–2.5 (26)	22 (0.9)	Pluggable terminal	SL2/T20

Table 44: Power Cable Sizing for IP20/UL Open Type Frames FA02–FA12 - (continued)

Frame	Terminal	Cross-section [mm ² (AWG)]	Torque [Nm (in-lb)]	Strip- ping length [mm (in)]	Connector type	Screw/ Lug type
FA06	All	16–35 ⁽²⁾ /16–50 ⁽³⁾ (6–2 ⁽²⁾ /6–1 ⁽³⁾)	14 (124)	17 (0.7)	Terminal	T30
FA07	Mains and motor	35–70 ⁽²⁾ /35–95 ⁽³⁾ (2–2/0 ⁽²⁾ / 2–3/0 ⁽³⁾)	14 (124)	22 (0.9)	Terminal	T30
	DC connection	16–35 ⁽²⁾ /16–50 ⁽³⁾ (6–2 ⁽²⁾ /6–1 ⁽³⁾)	14 (124)	17 (0.7)	Terminal	T30
FA08	Mains and motor	50–120 ⁽²⁾ /50–150 ⁽³⁾ (1–4/0 ⁽²⁾ / 1–300 MCM ⁽³⁾)	20 (177)	29 (1.1)	Terminal	T50
	DC connection	35–70 ⁽²⁾ /35–95 ⁽³⁾ (6–2 ⁽²⁾ /6–1 ⁽³⁾)	14 (124)	22 (0.9)	Terminal	T30
FA09	Mains and motor	2x120 (2x4/0)	19 (168)	–	M10 bolt	Cable lug
	DC connection	2x120 (2x4/0)	19 (168)	–	M10 bolt	Cable lug
FA10	Mains and motor	2x240 (2x400 MCM)	19 (168)	–	M10 bolt	Cable lug
	DC connection	2x240 (2x400 MCM)	19 (168)	–	M10 bolt	Cable lug
FA10b (ULH)	Mains and motor	2x120 ⁽⁴⁾ (2x4/0)	19 (168)	–	M10 bolt	Cable lug
FA11	Mains and motor	6x240 (6x500 MCM)	19/35 (168/310)	–	M10 bolt/M12 bolt	Cable lug
	Brake	2x185 (2x350 MCM)	19 (168)	–	M10 bolt	Cable lug
FA12	Mains and motor	6x240 (6x500 MCM)	19/35 (168/310)	–	M10 bolt/M12 bolt	Cable lug
	Brake	2x185 (2x350 MCM)	19 (168)	–	M10 bolt	Cable lug

1) 0.5–0.6 Nm ≤ 4 mm²; 0.7 Nm > 4 mm²; 4.4–5.3 in-lb ≤ AWG 24–12; 6.2 Nm > AWG 11–10.

2) Connectable conductor cross-section, fine-strand with cable end sleeve.

3) Connectable conductor cross-section, multi-wired.

4) Drives with product code: 04-147A: 50–150 mm² (AWG 1–300 MCM).

Table 45: Power Cable Sizing for IP21/UL Type 1 Frames (FK03–FK12)

Frame	Terminal	Cross-section [mm ² (AWG)]	Torque [Nm (in-lb)]	Strip-ping length [mm (in)]	Connector type	Screw/Lug type
FK03	All	1.5–6 (16–10) ⁽¹⁾	1.2 (17) ⁽²⁾	10 (0.4)	Terminal	T15
FK05	All	6–16 (10–6)	1.2–1.5 (17)	10 (0.4)	Terminal	T15
FK06	All	16–35 ⁽³⁾ / 16–50 ⁽⁴⁾ (6–2 ⁽³⁾ / 6–1 ⁽⁴⁾)	14 (124)	17 (0.7)	Terminal ⁽⁵⁾	T30
FK07	Mains and motor	35–70 ⁽³⁾ / 35–95 ⁽⁴⁾ (2–2/0 ⁽³⁾ / 2–3/0 ⁽⁴⁾)	14 (124)	22 (0.9)	Terminal ⁽⁵⁾	T30
	DC connection	16–35 ⁽³⁾ / 16–50 ⁽⁴⁾ (6–2 ⁽³⁾ / 6–1 ⁽⁴⁾)	14 (124)	17 (0.7)	Terminal	T30
FK07 (ULH)	Mains and motor	Drives with product codes 3H-43A0, 3H-61A0, and 3H-73A0: 16–35 ⁽³⁾ / 16–50 ⁽⁴⁾ (6–2 ⁽³⁾ / 6–1 ⁽⁴⁾)	14 (124)	17 (0.7)	Terminal ⁽⁵⁾	T30
		Drives with product codes 3H-90A0 and 3H-106A: 35–70 ⁽³⁾ / 35–95 ⁽⁴⁾ (2–2/0 ⁽³⁾ / 2–3/0 ⁽⁴⁾)	14 (124)	22 (0.9)	Terminal ⁽⁵⁾	T30
FK08	Mains and motor	50–120 ⁽³⁾ / 50–150 ⁽⁴⁾ (1–4/0 ⁽³⁾ / 1–300 MCM ⁽⁴⁾)	20 (170)	29 (1.1)	Terminal	T50
	DC connection	16–35 ⁽³⁾ / 16–50 ⁽⁴⁾ (6–2 ⁽³⁾ / 6–1 ⁽⁴⁾)	14 (124)	17 (0.7)	Terminal	T50
FK09	Mains and motor	2x120 (2x4/0)	19 (168)	–	M10 bolt	Cable lug
	DC connection	2x120 (2x4/0)	19 (168)	–	M10 bolt	Cable lug
FK10	Mains and motor	2x240 (2x400 MCM)	19 (168)	–	M10 bolt	Cable lug
	DC connection	2x240 (2x400 MCM)	19 (168)	–	M10 bolt	Cable lug
FK10b (ULH)	Mains and motor	2x120 ⁽⁶⁾ (2x4/0)	19 (168)	–	M10 bolt	Cable lug
FK11	Mains and motor	5x240 (5x500 MCM)	19/35 (168/310)	–	M10 bolt/M12 bolt	Cable lug
FK12	Mains and motor	6x240 (6x500 MCM)	19/35 (168/310)	–	M10 bolt/M12 bolt	Cable lug

1) Drives with product code 04-24A0: 1.5–10 (16–7).

 2) 0.5–0.6 Nm ≤ 4 mm²; 0.7 Nm > 4 mm²; 4.4–5.3 in-lb ≤ AWG 24–12; 6.2 Nm > AWG 11–10.

3) Connectable conductor cross-section, fine-strand with cable end sleeve.

4) Connectable conductor cross-section, multi-wired.

5) If the drive is fitted with a fuse (+AJFX), use a cable a lug for mains and an MS bolt.

6) Drives with product code: 04-147A: 50–150 mm² (AWG 1–300 MCM).

Table 46: Power Cable Sizing for IP54/IP55/UL Type 12 Frames (FB03–FB12)

Frame	Terminal	Cross-section [mm ² (AWG)]	Torque [Nm (in-lb)]	Strip- ping length [mm (in)]	Connector type	Screw/ Lug type
FB03	All	1.5–6 (16–10) Drives with product code 04-24A0: 1.5–10 (16–7)	1.2 (17) ⁽¹⁾	10 (0.4)	Terminal	T15
FB05	All	6–16 (10–6)	1.2–1.5 (17)	10 (0.4)	Terminal	T15
FB06	All	16–35 ⁽²⁾ /16–50 ⁽³⁾ (6–2 ⁽²⁾ / 6–1 ⁽³⁾)	9 (80)	20 +3/0 (0.8)	Slider terminal ⁽⁴⁾	T30
FB07	Mains and motor	35–70 ⁽²⁾ / 35–95 ⁽³⁾ (2–2/0 ⁽²⁾ / 2–3/0 ⁽³⁾)	16 (142)	27 +3/0 (1)	Slider terminal ⁽⁴⁾	T50
	DC connection	16–35 ⁽²⁾ / 16–50 ⁽³⁾ (6–2 ⁽²⁾ / 6–1 ⁽³⁾)	9 (80)	20 +3/0 (0.8)	Slider terminal	T30
FB07 (ULH)	Mains and motor	Drives with product codes 3H-43A0, 3H-61A0 and 3H-73A0: 16–35 ⁽²⁾ / 16–50 ⁽³⁾ (6–2 ⁽²⁾ / 6–1 ⁽³⁾)	14 (124)	17 (0.7)	Terminal ⁽⁵⁾	T30
		Drives with product codes 3H-90A0 and 3H-106A: 35–70 ⁽²⁾ / 35–95 ⁽³⁾ (2–2/0 ⁽²⁾ / 2–3/0 ⁽³⁾)	14 (124)	22 (0.9)	Terminal ⁽⁵⁾	T30
FB08	Mains and motor	50–120 ⁽²⁾ / 50–120 ⁽³⁾ (1–4/0 ⁽²⁾ / 1–4/0 ⁽³⁾)	20 (177)	30 +3/0 (1.2)	Slider terminal	T50
	DC connection	35–70 ⁽²⁾ / 35–95 ⁽³⁾ (2–2/0 ⁽²⁾ / 2–3/0 ⁽³⁾)	16 (142)	27 +3/0 (1)	Slider terminal	T50
FB09	Mains and motor	2x120 (2x4/0)	19 (168)	–	M10 bolt	Cable lug
	DC connection	2x120 (2x4/0)	19 (168)	–	M10 bolt	Cable lug
FB10	Mains and motor	2x240 (2x400 MCM)	19 (168)	–	M10 bolt	Cable lug
	DC connection	2x240 (2x400 MCM)	19 (168)	–	M10 bolt	Cable lug
FB10b (ULH)	Mains and motor	2x120 ⁽⁵⁾ (2x4/0)	19 (168)	–	M10 bolt	Cable lug
FB11	Mains and motor	5x240 (5x500 MCM)	19/35 (168/310)	–	M10 bolt/M12 bolt	Cable lug
FB12	Mains and motor	6x240 (6x500 MCM)	19/35 (168/310)	–	M10 bolt/M12 bolt	Cable lug

 1) 0.5–0.6 Nm ≤ 4 mm²; 0.7 Nm > 4 mm²; 4.4–5.3 in-lb ≤ AWG 24–12; 6.2 Nm > AWG 11–10.

- 2) Connectable conductor cross-section, fine-strand with cable end sleeve.
- 3) Connectable conductor cross-section, multi-wired.
- 4) If the drive is fitted with a fuse (+AJFX), use a cable a lug for mains and an M5 bolt.
- 5) Drives with product code: 04-147A: 50–150 mm² (AWG 1–300 MCM).

8.6 Cooling and Power Loss

8.6.1 Power Losses

8.6.1.1 Overview

The frequency converter dissipates heat due to power loss when powered on and running. The main heat dissipating sources are:

- Cooling of power components (IGBTs, SCRs, or rectifiers).
- DC-link inductor (in 6-pulse drives), or LCL filter (in ultra low-harmonic drives)
- DC-link capacitors
- Busbars

The frequency converters can be mounted side by side, and a speed-controlled fan is used for forced cooling.

The power losses of the frequency converter are listed in [8.6.1.2 Power Loss, 6-pulse Frequency Converters](#) and [8.6.1.3 Power Loss, Ultra Low-harmonic Frequency Converters](#). Power loss data at other operating points according to IEC 61800-9-2 is available in MyDrive® Energy (<https://energy.mydrive.danfoss.com/>).

8.6.1.2 Power Loss, 6-pulse Frequency Converters

Table 47: Power Loss by Unit, 6-pulse Frequency Converters

Product code ⁽¹⁾	Low overload		High overload	
	P _{typ} ⁽²⁾ [W]	P _{max} ⁽³⁾ [W]	P _{typ} ⁽²⁾ [W]	P _{max} ⁽³⁾ [W]
3N04-01A3	36	39	35	37
3N04-01A8	38	43	36	39
3N04-02A4	41	51	40	45
3N04-03A0	44	60	42	53
3N04-04A0	49	73	44	60
3N04-05A6	57	86	49	68
3N04-07A2	66	107	57	86
3N04-09A2	75	139	64	108
3N04-12A5	84	179	76	126
3N04-16A0	105	229	91	176
3N04-24A0	142	342	103	213
3N04-31A0	187	432	152	319
3N04-38A0	215	529	179	408
3N04-43A0	241	596	214	506
3N04-61A0	264	608	203	433
3N04-73A0	314	761	261	602
3N04-90A0	365	886	307	681

Table 47: Power Loss by Unit, 6-pulse Frequency Converters - (continued)

Product code ⁽¹⁾	Low overload		High overload	
	P _{typ} ⁽²⁾ [W]	P _{max} ⁽³⁾ [W]	P _{typ} ⁽²⁾ [W]	P _{max} ⁽³⁾ [W]
3N04-106A	429	1062	366	863
3N04-147A	571	1508	414	991
3N04-170A	701	1810	608	1514
3N04-206A	976	2316	827	1867
3N04-245A	1114	2651	955	2172
3N04-302A	1369	3438	1118	2658
3N04-385A	1648	4053	1357	3041
3N04-395A	1764	4061	1445	3029
3N04-480A	2117	5123	1732	3969
3N04-588A	2570	6348	2111	4975
3N04-658A	3235	7576	2940	6698
3N04-736A	3578	8553	3242	7539
3N04-799A	3854	9339	3400	7962
3N04-893A	4438	10547	4045	9321
3N04-1000	4869	11823	4357	10207
3N04-1120	5152	13354	4622	11638
3N04-1260	5772	15402	5042	12981

1) The product code consists of the product type, mains voltage, and current rating code of the model code. For more information, see [12.2.1 Overview](#).

2) Absolute power loss at 50% rated output frequency, and 50% of rated current.

3) Absolute power loss at 100% rated output frequency, and 100% of rated current.

8.6.1.3 Power Loss, Ultra Low-harmonic Frequency Converters

Table 48: Power Loss by Unit

Product code ⁽¹⁾	Low overload		High overload	
	P _{typ} [W]	P _{max} [W]	P _{typ} ⁽²⁾ [W]	P _{max} ⁽³⁾ [W]
3H04-43A0	272	603	241	471
3H04-61A0	348	889	272	603
3H04-73A0	409	1174	348	889
3H04-90A0	471	1387	409	1174
3H04-106A	579	1857	471	1387
3H04-147A	490	1728	449	1067
3H04-170A	637	2135	490	1728
3H04-206A	770	2967	637	2135
3H04-245A	992	3793	770	2967
3H04-302A	1230	4863	992	3793

1) The product code consists of the product type, mains voltage, and current rating code of the model code. For more information, see [12.2.1 Overview](#).

2) Absolute power loss at 50% rated output frequency, and 50% of rated current.

3) Absolute power loss at 100% rated output frequency, and 100% of rated current.

8.6.2 Airflow and Noise Levels

To ensure proper cooling of the drive, proper flow of air is needed. The values state the maximum flow at full fan speed for the respective frames.

During operation, the drive emits noise. The sound pressure level depends on the size of the drive, the actual load, and surrounding conditions. The main source of the noise is the cooling fan of the drive. For Fx09-Fx12 frames airflow data is stated both for the heat sink fan and top or door fan. The heat sink fan is the main fan providing airflow over the heat sink, and the top or door fan provide additional airflow in the control electronics.

Follow local regulations on the working environment and the protection of personnel regarding acoustic noise levels.

Table 49: Airflow and Noise Levels for IP20/UL Open Type Frames (FA02–FA12)

Frame	Airflow (m ³ /h [cfm])		Noise level dB(A)		
	Heat sink fan	Top/door fan	40% fan speed	80% fan speed	100% fan speed
FA02	50 (29)	–	41	49	52
FA04	165 (97)	–	40	55	59
FA05	280 (165)	–	46	61	65
FA06	280 (165)	–	46	57	62
FA07	280 (165)	–	50	64	71
FA08	370 (218)	–	54	65	71
FA09	638 (375)	150 (88)	63	75	78
FA10	638 (375)	150 (88)	57	72	79
FA11	994 (585)	660 (390)	61	71	76
FA12	1206 (710)	660 (390)	62	74	78

Table 50: Airflow and Noise Levels for IP21/UL Type 1 Frames (FK03–FK12)

Frame	Airflow (m ³ /h [cfm])		Noise level dB(A)		
	Heat sink fan	Top/door fan	40% fan speed	80% fan speed	100% fan speed
FK03	–	–	–	–	–
FK05	–	–	–	–	–
FK06	280 (165)	–	46	57	62
FK07	280 (165)	–	50	64	71
FK08	370 (218)	–	54	65	71
FK09	638 (375)	144 (85)	57	73	77
FK10	638 (375)	204 (120)	57	72	79
FK11	994 (585)	595 (350)	63	73	79
FK12	1206 (710)	1020 (600)	71	75	79

Table 51: Airflow and Noise Levels for IP54/UL Type 12 Frames (FB03–FB12)

Frame	Airflow (m ³ /h [cfm])		Noise level dB(A)		
	Heat sink fan	Top/door fan	40% fan speed	80% fan speed	100% fan speed
FB03	–	–	–	–	–
FB05	–	–	–	–	–
FB06	280 (165)	–	46	57	67
FB07	280 (165)	–	50	64	71
FB08	370 (218)	–	54	65	71
FB09	638 (375)	144 (85)	57	73	77
FB10	638 (375)	204 (120)	57	72	79
FB11	994 (585)	595 (350)	63	73	79
FB12	1206 (710)	1020 (600)	71	75	79

8.7 Energy Efficiency Data

The iC7 drives are designed according to the requirements in IEC61800-9-2 and are all compliant to efficiency class IE2. Relative loss for the drive is stated on the product label.

The IE class for variable frequency drives is determined in a single operation point at 100% current and 90% output frequency. The losses include EMC filters and brake choppers, for example, and are determined as factory settings.

For detailed information, refer to the MyDrive® Energy tool (<https://energy.mydrive.danfoss.com/>).

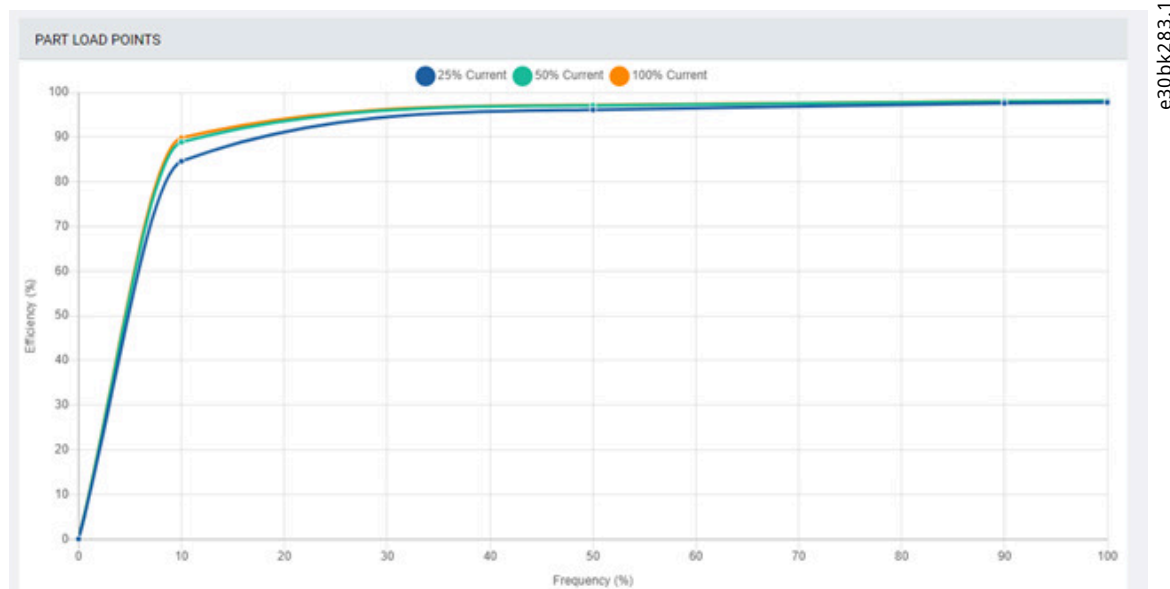
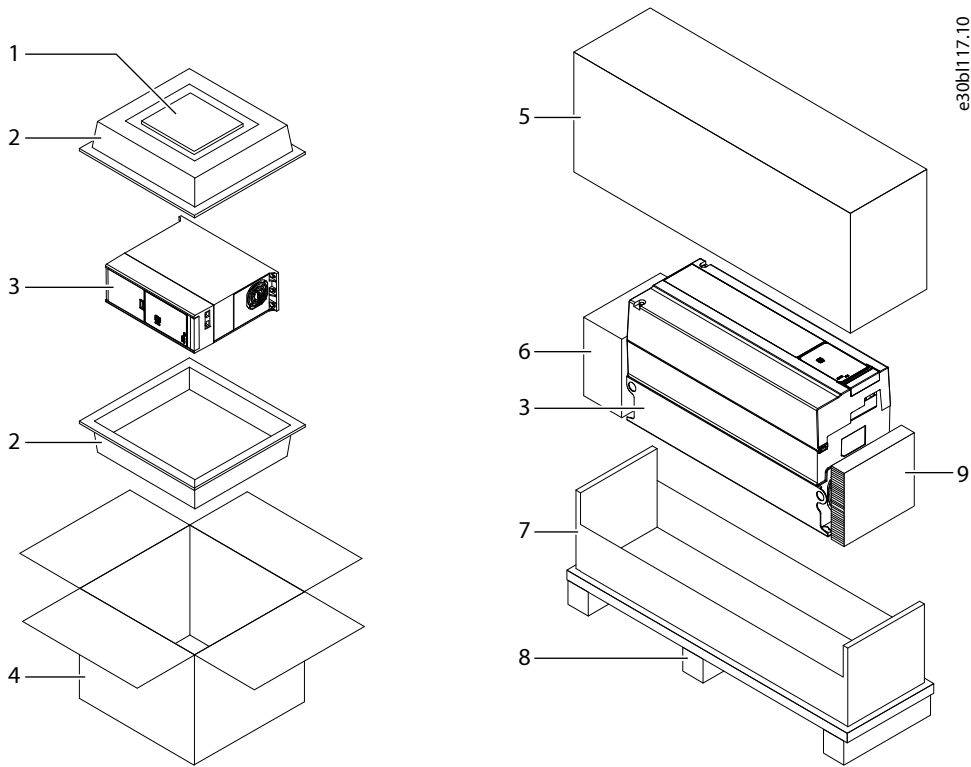

Figure 9: Example of MyDrive® Energy data

8.8 Packaging



e30bl17.10

Figure 10: Type A Packaging for Frames Fx02-Fx05 (Left) and Type B Packaging for Frames Fx06-Fx08 (Right)

1	Installation and safety guides and accessory bag	2	Insert
3	Drive	4	Cardboard box
5	Cardboard cover	6	Accessory box
7	Cardboard tray	8	Pallet
9	Spacer		

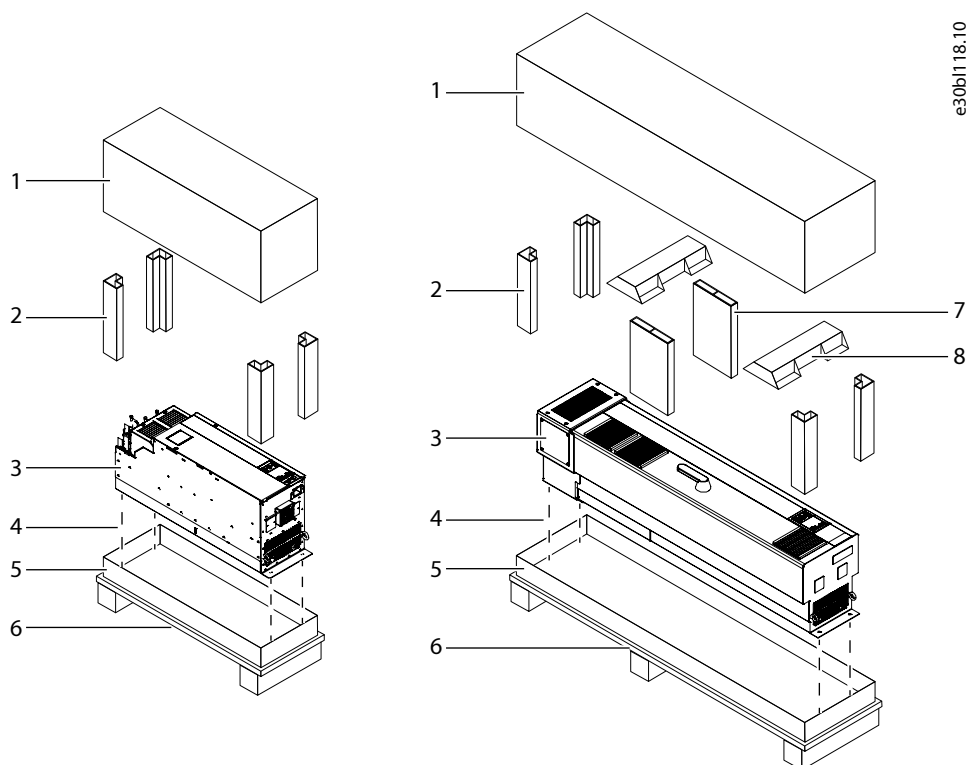

Figure 11: Type C Packaging for Frames FA09-FA12, FK09a, FK10a, FK11, and FK12 (Left) and Type D Packaging for Frames FK09c and FK10c (Right)

1	Cardboard cover	2	Corner spacers
3	Drive	4	Mounting screws to secure the drive to the pallet
5	Cardboard tray	6	Pallet
7	Side spacers	8	Top spacers

The packaging dimensions and weight depend on the frame. The weight given in the tables is the maximum weight of the drive shipment. Specific weights for each frame are also listed in the Danfoss Product Configuration Tool.

Table 52: Package Dimensions for IP20/UL Open Type Frames

Frame	Height [mm (in)]	Width [mm (in)]	Depth [mm (in)]	Weight [kg (lb)]	Packaging concept
FA02a	196 (7.76)	320 (12.6)	330 (13)	5.25 (11.6)	A
FA02b	196 (7.76)	320 (12.6)	330 (13)	5.5 (12.1)	A
FA03a	220 (8.66)	320 (12.6)	330 (13)	6.15 (13.6)	A
FA03b	220 (8.66)	320 (12.6)	330 (13)	6.45 (14.2)	A
FA04a	291 (11.5)	394 (15.5)	544 (21.4)	12.6 (27.8)	A
FA04b	291 (11.5)	394 (15.5)	544 (21.4)	12.8 (28.2)	A
FA05a	326 (12.8)	394 (15.5)	544 (21.4)	15.1 (33.2)	A
FA05b	326 (12.8)	394 (15.5)	544 (21.4)	15.6 (34.3)	A
FA06	271 (10.67)	434 (17.09)	731 (28.8)	26 (57)	B
FA07	294 (11.6)	471 (18.53)	801 (31.5)	38 (84)	B
FA08	492 (19.4)	382 (15.04)	1048 (41.3)	62 (137)	B
FA09	559 (22)	991 (39)	457 (18)	94 (208)	C

Table 52: Package Dimensions for IP20/UL Open Type Frames - (continued)

Frame	Height [mm (in)]	Width [mm (in)]	Depth [mm (in)]	Weight [kg (lb)]	Packaging concept
FA10	559 (22)	1194 (47)	546 (21.5)	143 (315)	C
FA10b	559 (22)	1397 (55)	660 (26)	174 (384)	C
FA11	757 (29.8)	1760 (69.3)	793 (31.2)	281 (620)	C
FA12	757 (29.8)	1760 (69.3)	793 (31.2)	357 (787)	C

Table 53: Package Dimensions for IP21/UL Type 1 Frames

Frame	Height [mm (in)]	Width [mm (in)]	Depth [mm (in)]	Weight [kg (lb)]	Packaging concept
FK03	–	–	–	–	–
FK05	–	–	–	–	–
FK06	271 (10.67)	434 (17.09)	731 (28.8)	28 (61)	B
FK07	294 (11.6)	471 (18.53)	801 (31.5)	38 (84)	B
FK08	492 (19.4)	382 (15.04)	1048 (41.3)	70 (154)	B
FK09a	559 (22)	1168 (46)	457 (18)	104 (229)	C
FK09c	533 (21)	1829 (72)	559 (22)	128 (282)	D
FK10a	559 (22)	1397 (55)	559 (22)	158 (348)	C
FK10b	559 (22)	1397 (55)	661 (26)	177 (390)	C
FK10c	559 (22)	2388 (94)	610 (24)	208 (458)	D
FK11	767 (30.2)	2191 (86.3)	871 (34.3)	294 (648)	C
FK12	767 (30.2)	2191 (86.3)	871 (34.3)	380 (838)	C

Table 54: Package Dimensions for IP54/IP55/UL Type 12 Frames

Frame	Height [mm (in)]	Width [mm (in)]	Depth [mm (in)]	Weight [kg (lb)]	Packaging concept
FB03	–	–	–	–	–
FB05	–	–	–	–	–
FB06	271 (10.67)	434 (17.09)	731 (28.8)	28 (61)	B
FB07	294 (11.6)	471 (18.53)	801 (31.5)	38 (84)	B
FB08	492 (19.4)	382 (15.04)	1048 (41.3)	70 (154)	B
FB09a	559 (22)	1168 (46)	457 (18)	104 (229)	C
FB09c	533 (21)	1829 (72)	559 (22)	128 (282)	D
FB10a	559 (22)	1397 (55)	559 (22)	158 (348)	C
FB10b	559 (22)	1397 (55)	660 (26)	177 (390)	C
FB10c	559 (22)	2388 (94)	610 (24)	208 (458)	D
FB11	767 (30.2)	2191 (86.3)	871 (34.3)	294 (648)	C
FB12	767 (30.2)	2191 (86.3)	871 (34.3)	380 (838)	C

8.9 Cable Length

See [Table 55](#) for details on the lengths of the different cable types.

For EMC compliance and filters, see [8.10.1 EMC Compliance Levels](#).

Table 55: Cable Lengths

Cable type	Maximum length [m (ft)]
Motor cable	Shielded: 300 (984) For EMC compliance, see Table 57 .
	Unshielded: 300 (984)
DC cable (+DC, -DC)	Contact Danfoss.
Control panel	10 (33) ⁽¹⁾

1) Use the Control Panel Cable, available in 2.5 m (8 ft), 5 m (16 ft), and 10 m (33 ft).

8.10 EMC

8.10.1 EMC Compliance Levels

The drives are designed and tested to comply with relevant EMC standards. The performance level depends on the actual drive and selected EMC compliance level.

The EMC compliance levels are tested under the following conditions:

- The drive (with options if relevant)
- Shielded control and communication cables
- External control with digital I/O and analog control
- Single motor connected with shielded cable: Lapp Ölflex Classic 100CY (single cable) for Fx02–Fx08, and Helukabel Top Serv 109 for Fx09–Fx12
- Standard drive settings

NOTICE

According to the EMC Directive, a system is defined as a combination of several types of equipment, finished products, and/or components combined, designed and/or put together by the same person (system manufacturer) intended to be placed on the market for distribution as a single functional unit for an end user and intended to be installed and operated together to perform a specific task.

The EMC directive applies to products/systems and installations, but in case the installation is built up of CE-marked products/systems, the installation can also be considered compliant with the EMC directive. Installations are not CE-marked.

According to the EMC Directive, as a manufacturer of products/systems is responsible for obtaining the essential requirements of the EMC directive and attaching the CE mark. For systems involving load sharing and other DC terminals, Danfoss can only ensure compliance with the EMC Directive when combinations of Danfoss products are connected as described in the technical documentation.

If any third-party products are connected to the load share or other DC terminals on the drives, Danfoss cannot guarantee that the EMC requirements are fulfilled.

If installed in residential environments, and not compliant to category C1, the drive may not provide adequate protection to radio reception in such locations. In such cases, supplementary mitigation measures might be required, for example, the use of shielding or increasing the distance between affected products.

If not compliant to category C1 or C2, the drive must not be installed in a public low-voltage network, which supplies residential premises. Radio frequency interference can be expected if used on such a network. Follow the instructions for installation given in the product-specific installation guide.

If the RFI filters of the drive are disabled, the drive fulfills category C4. In this case, the drive is intended to be used in an installation powered by a supply which does not radiate, for example, a dedicated transformer or generator, or low-voltage underground lines. If guidelines for installation are not followed carefully, radio frequency interference can be expected.

8.10.2 Emission Requirements

According to the EMC product standard for variable frequency drives, EN/IEC 61800-3, the EMC requirements depend on the intended use of the drive. Four categories are defined in the EMC product standard. The definitions of the 4 compliance classes are given in [Table 56](#).

Table 56: Compliance Class and Intended Use of the Drive

Compliance class	Intended use of the drive
C1	Drives installed in the 1st environment (home and office) with a supply voltage less than 1000 V.
C2	Drives installed in the 1st environment (home and office) with a supply voltage less than 1000 V, which are neither plug-in nor movable and are intended for installation and commissioning by a professional.
C3	Drives installed in the 2nd environment (industrial) with a supply voltage lower than 1000 V.
C4	Drives installed in the 2nd environment (industrial) with a supply voltage equal to or above 1000 V or rated current equal to or above 400 A or intended for use in complex systems.

The drives are designed to comply with 1 of the following 4 categories, defined in the EMC product standard, EN/IEC 61800-3.

Table 57: EMC Emission Compliance Levels at Maximum Motor Cable Length

EMC category (model code)	Frame	EN/IEC 61800-3 compliance class					
		Conducted emission			Radiated emission		
		C1	C2	C3	C1	C2	C3
		Cable length [m (ft)]					
F1 – Combined C1 and C2 filter	Fx02–Fx08	50 (164)	150 (492)	150 (492)	No	Yes	Yes
F2 – C2 filter	Fx02–Fx08	–	150 (492)	150 (492)	No	Yes	Yes
	Fx09–Fx12	–	150 (492)	150 (492)	No	Yes	Yes
F3 – C3 filter	Fx02–Fx05	–	–	250 (820)	No	No	Yes
	Fx06–Fx08	–	–	300 (984)	No	No	Yes
	Fx09–Fx12	–	–	150 (492)	No	No	Yes

For frames Fx02–Fx08 emission levels are measured with a single motor cable, and do not apply for parallel motor cables. Using cables that are longer than the specified maximum length can result in exceeding emission level limits.

8.10.3 Immunity Requirements

The frequency converters are specified and tested to comply with industrial requirements for electromagnetic immunity. Compliance with domestic limits is fulfilled with a safety margin, as the immunity requirements are lower than for industrial installations.

9 Exterior and Terminal Dimensions

9.1 Overview

The drawings included in the design guide provide the main dimensions of the different frames. All dimensions are in mm (in). See [10.8.5 Recommended Fasteners](#) for the maximum weights of each frame.

The drawings are general drawings and can contain details that are not relevant for the shipped drive. All drawings are in first-angle projection. For frames Fx06–Fx12, the center of gravity is shown in the drawings.

Drawings in various formats, for example, as .stp files and EPLAN files with static macros are available for download at <https://www.danfoss.com/en/service-and-support/documentation/>. EPLAN files with static and configurable macros are available in the EPLAN Data Portal at www.eplandataportal.com.

9.2 IP20/UL Open Type Frames (FA02–FA12)

9.2.1 FA02a Dimensions

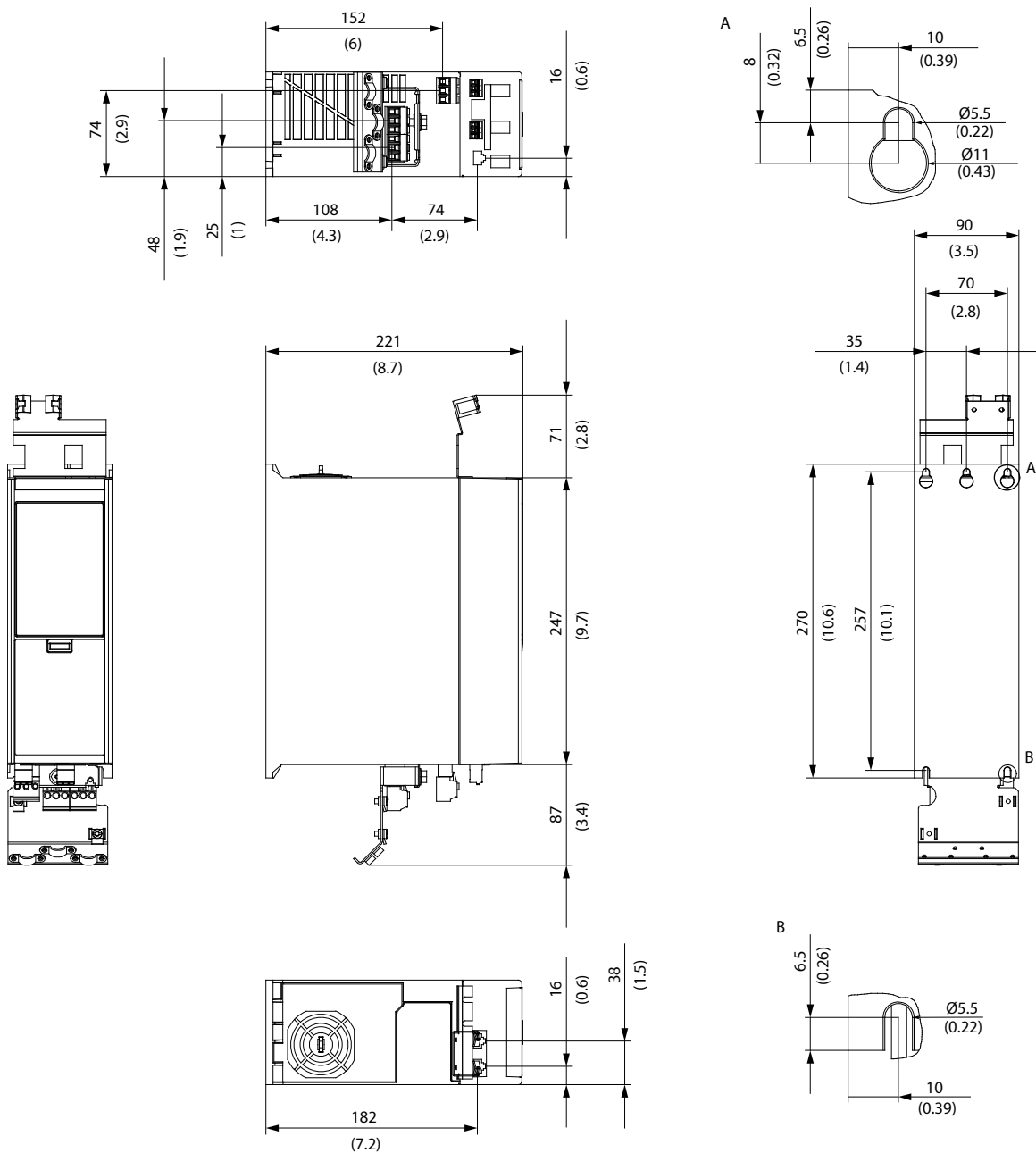

e30bi463.10

Figure 12: FA02a Dimensions

9.2.2 FA02b Dimensions

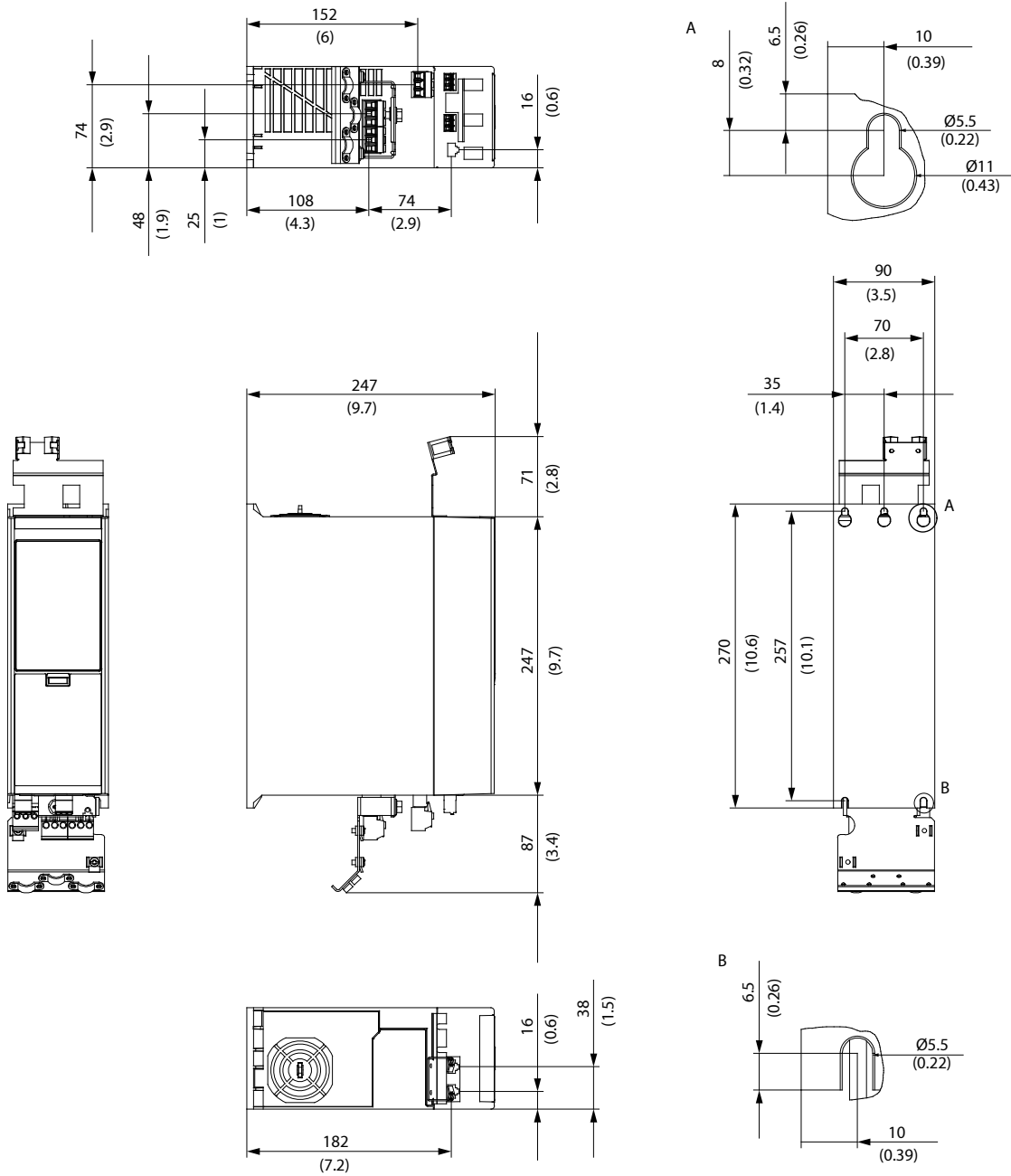

e30bj464.10

Figure 13: FA02b Dimensions

9.2.3 FA04a Dimensions

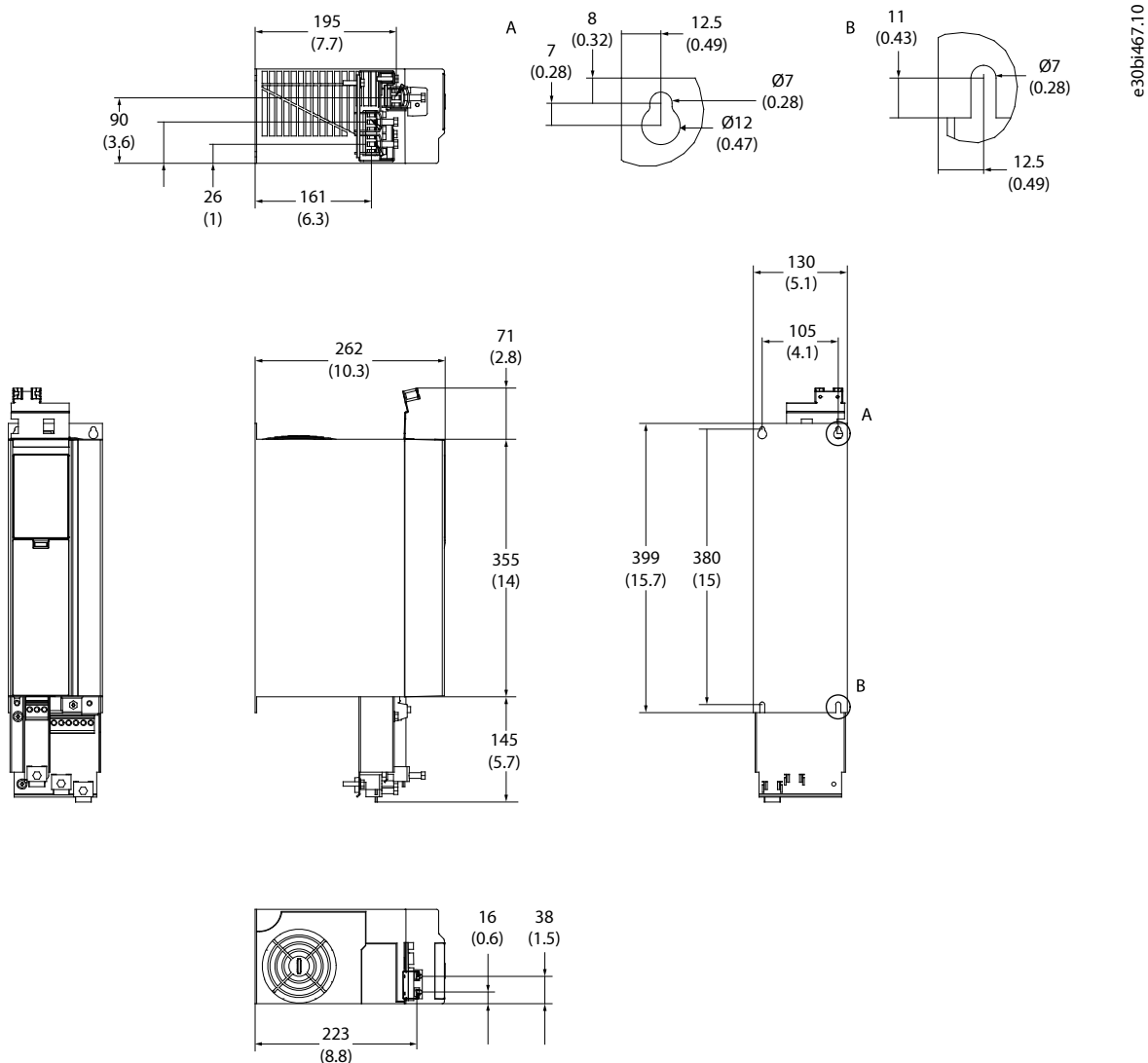

e30bi467.10

Figure 14: FA04a Dimensions

9.2.4 FA04b Dimensions

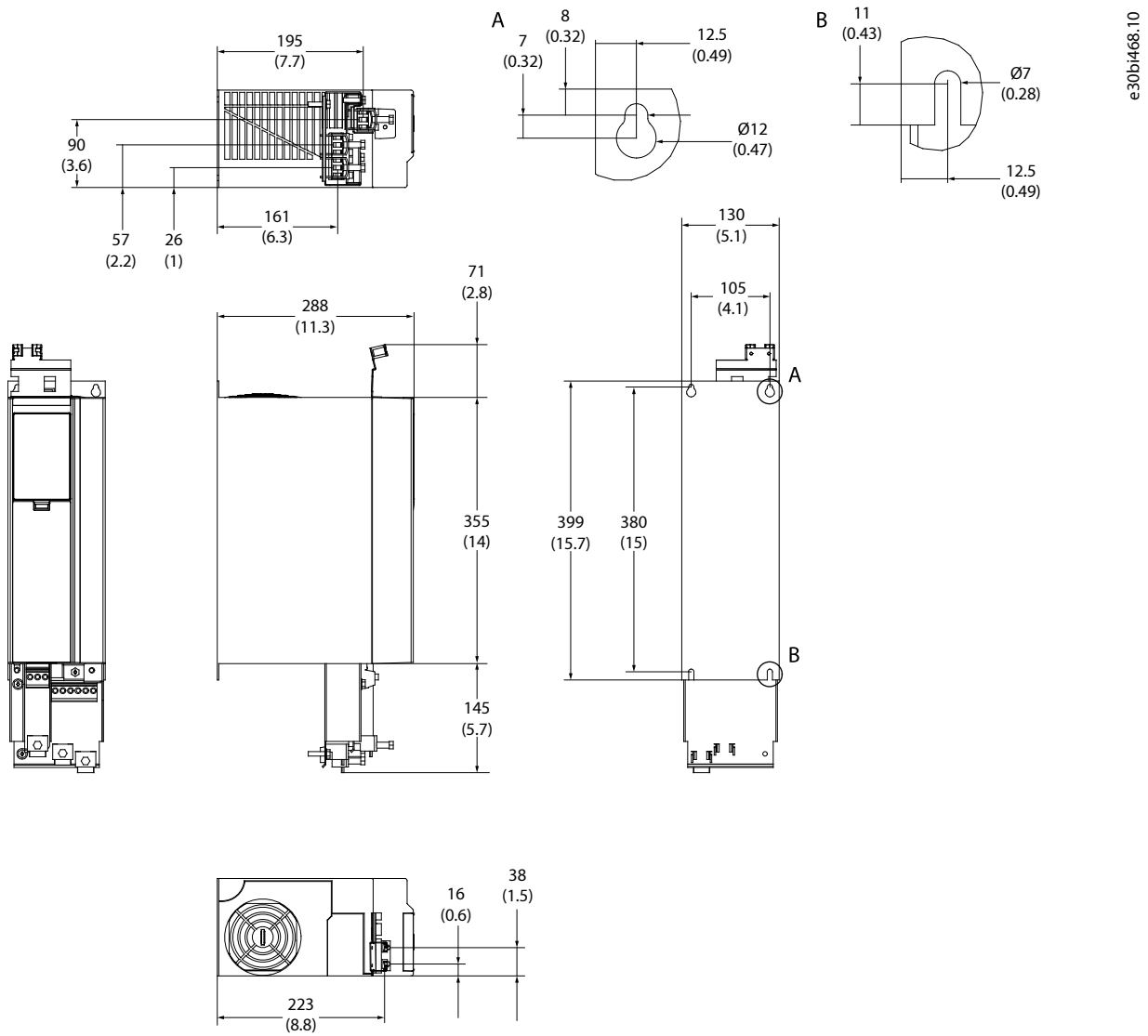

e30bi468.10

Figure 15: FA04b Dimensions

9.2.5 FA05a Dimensions

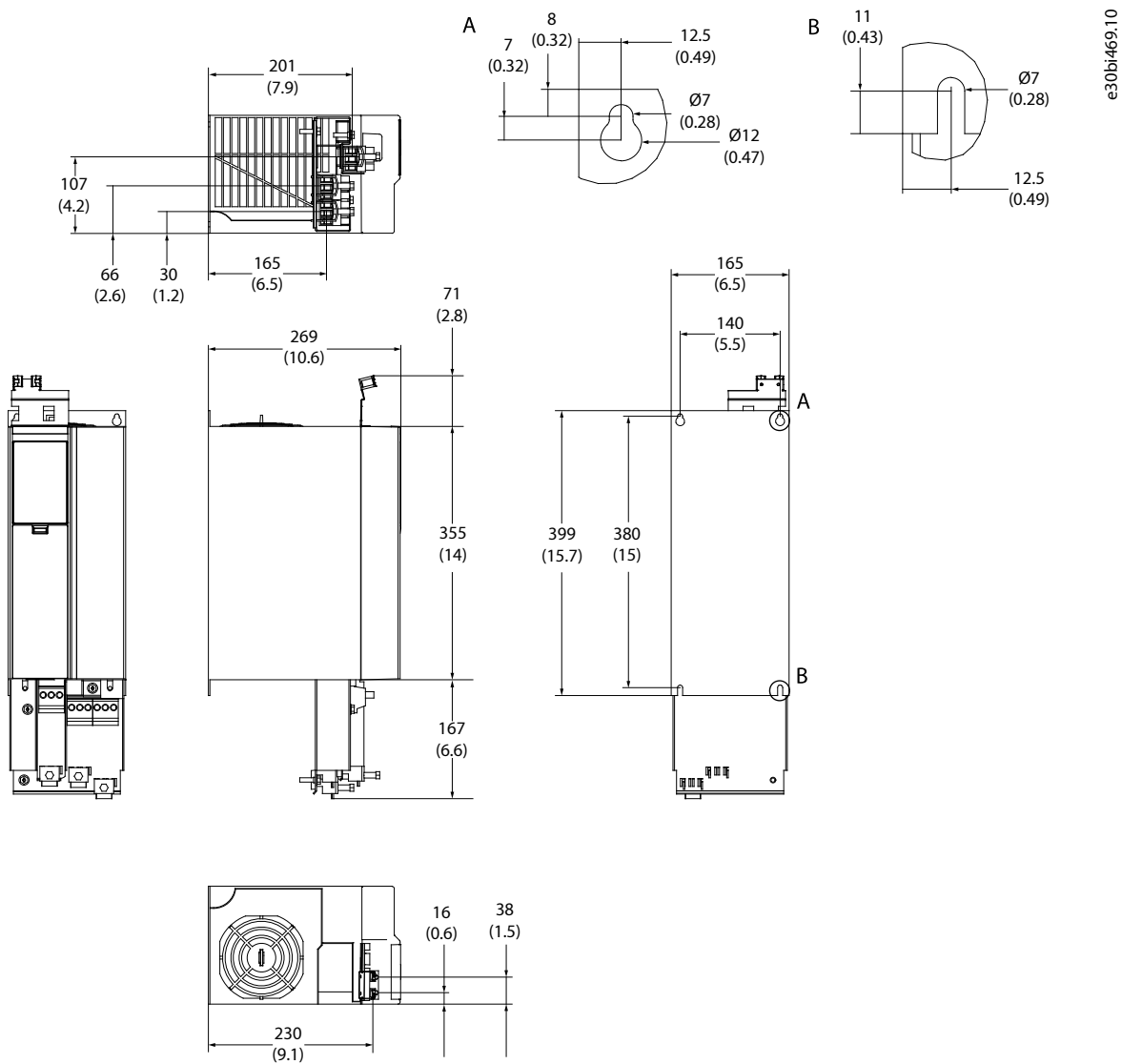

e30br469.10

Figure 16: FA05a Dimensions

9.2.6 FA05b Dimensions

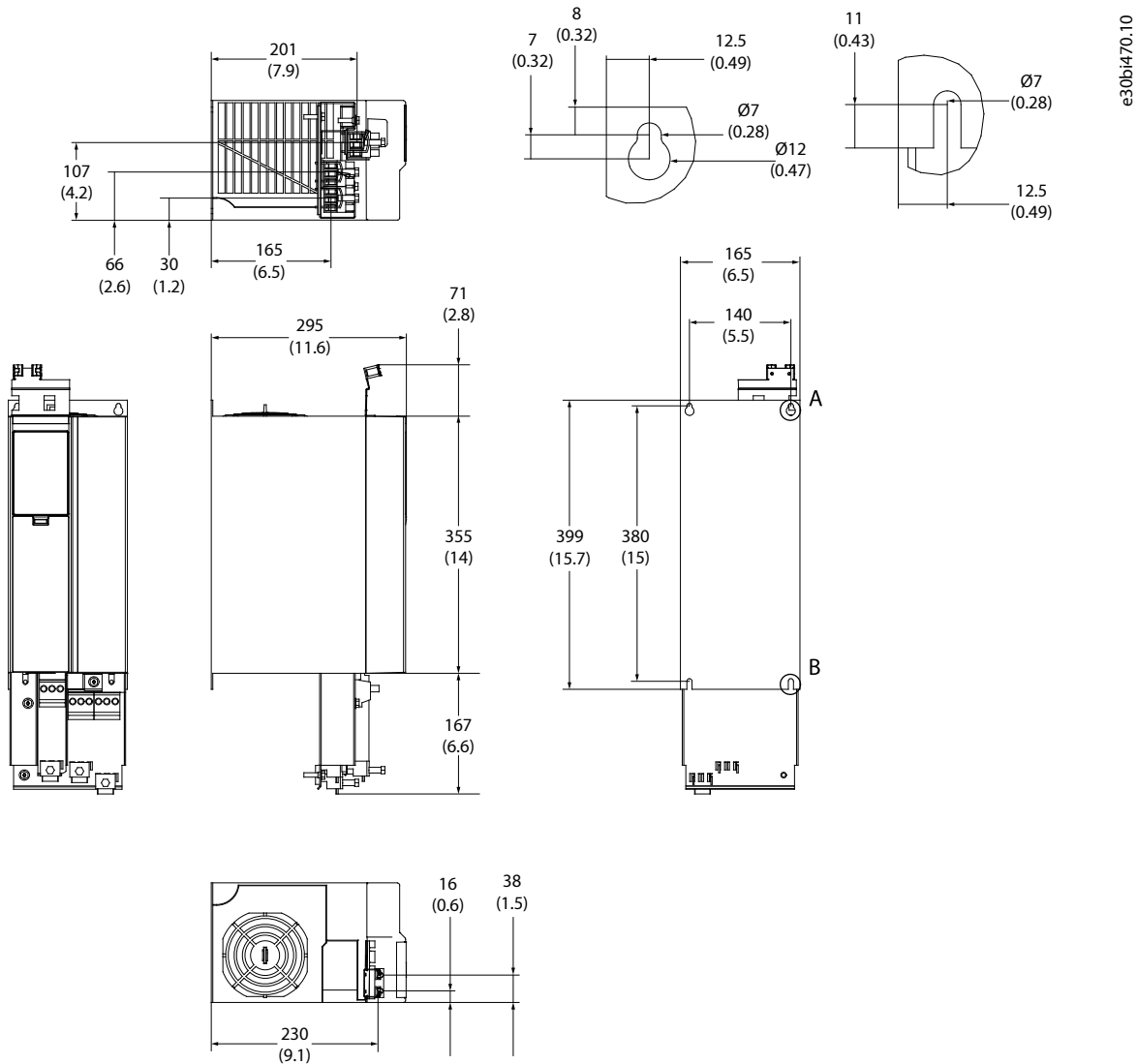

e30b470.10

Figure 17: FA05b Dimensions

9.2.7 FA06 Dimensions

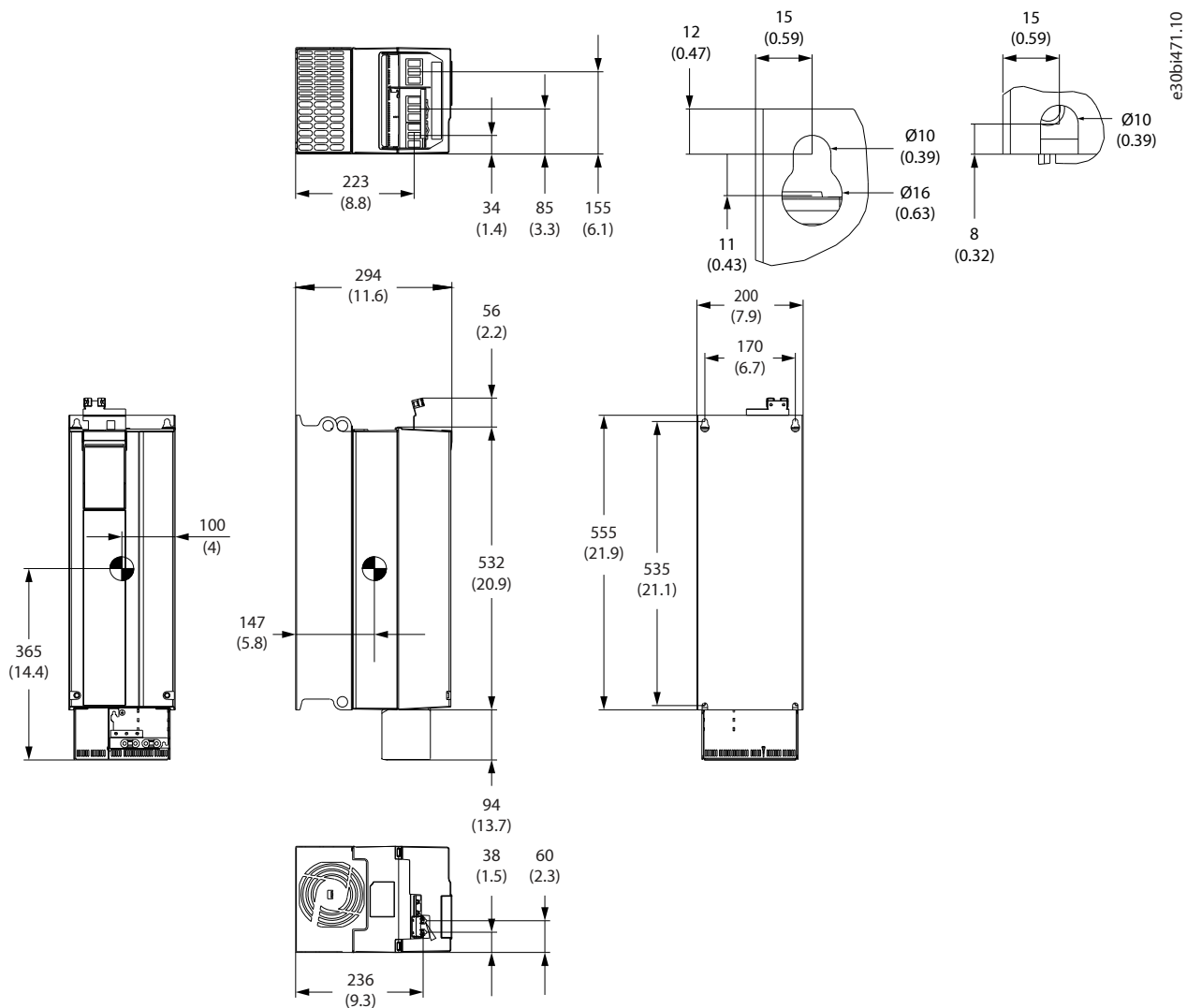
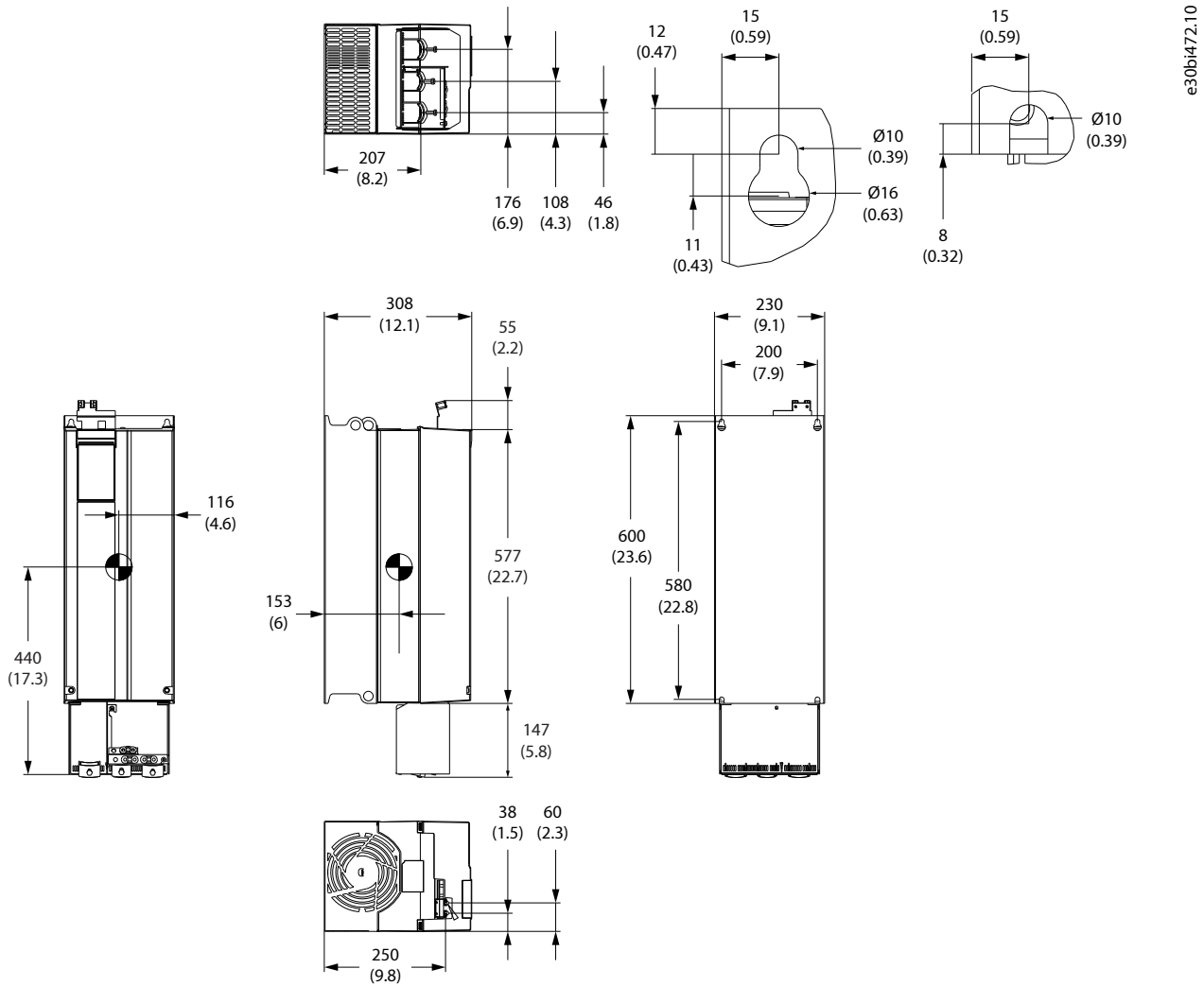

Figure 18: FA06 Dimensions

9.2.8 FA07 Dimensions



e30b1472.10

Figure 19: FA07 Dimensions

9.2.9 FA08 Dimensions

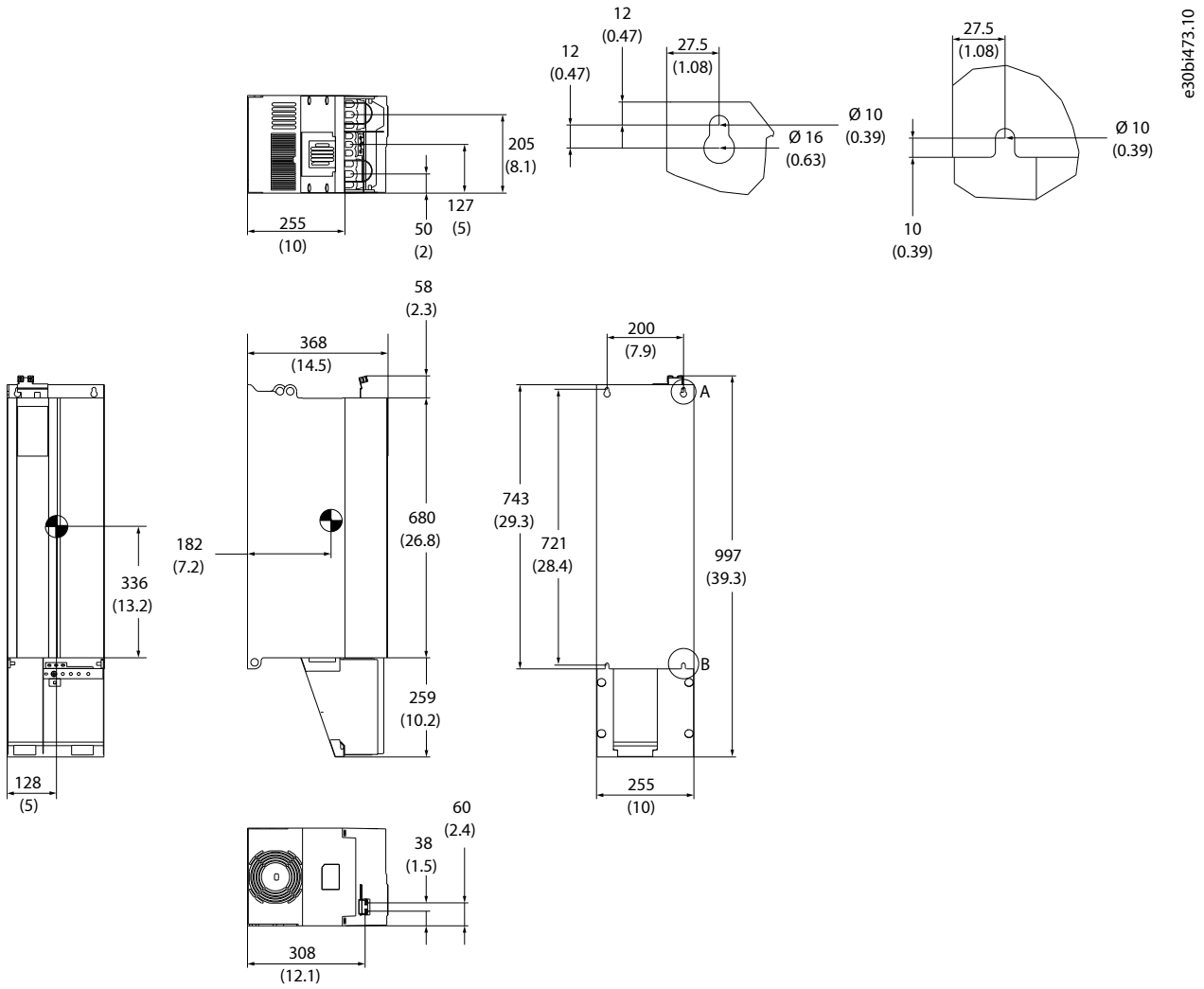
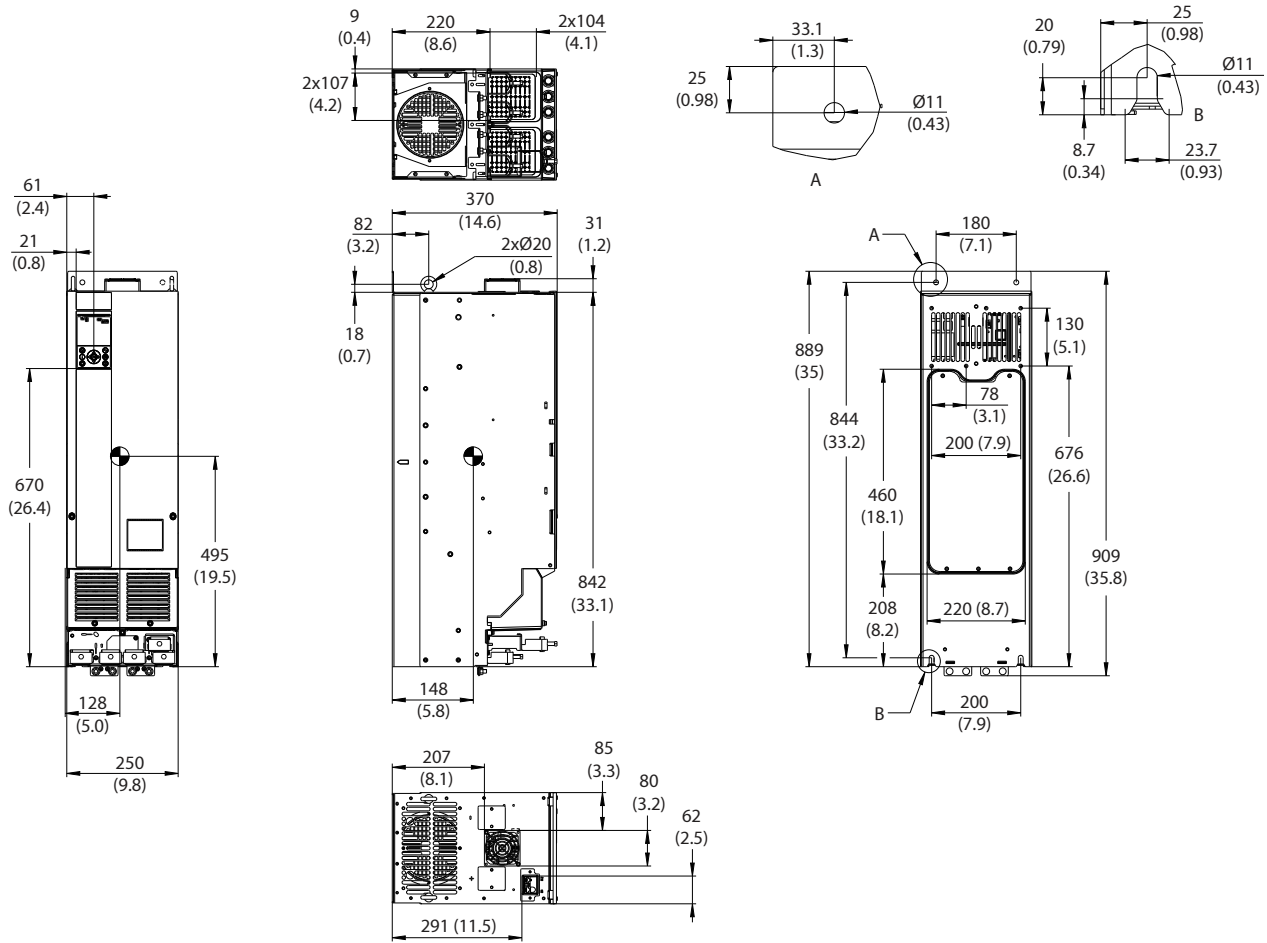

Figure 20: FA08 Dimensions

9.2.10 FA09 Dimensions



e30bj213.11

Figure 21: FA09 Exterior Dimensions

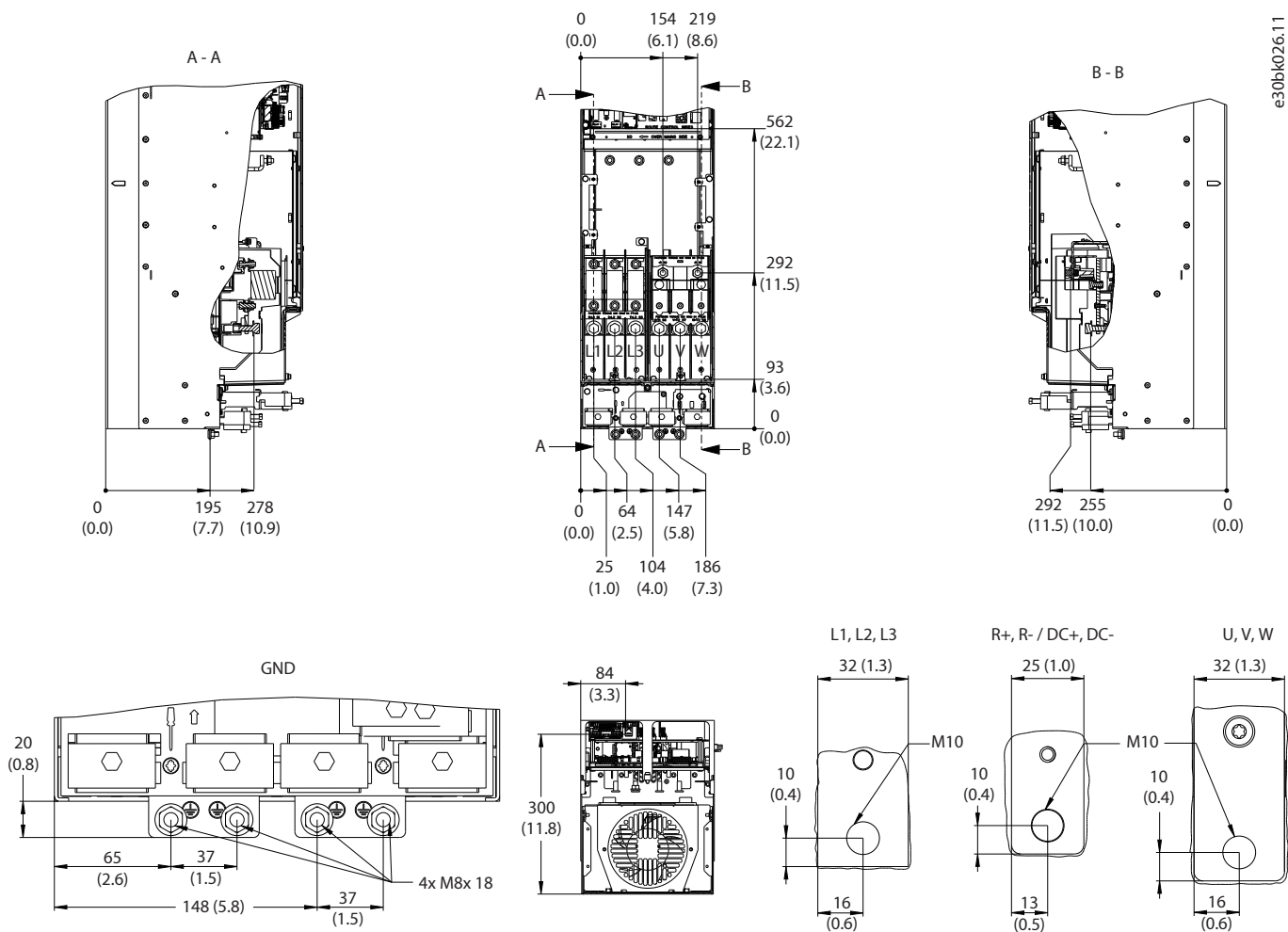

9.2.11 FA10 Dimensions

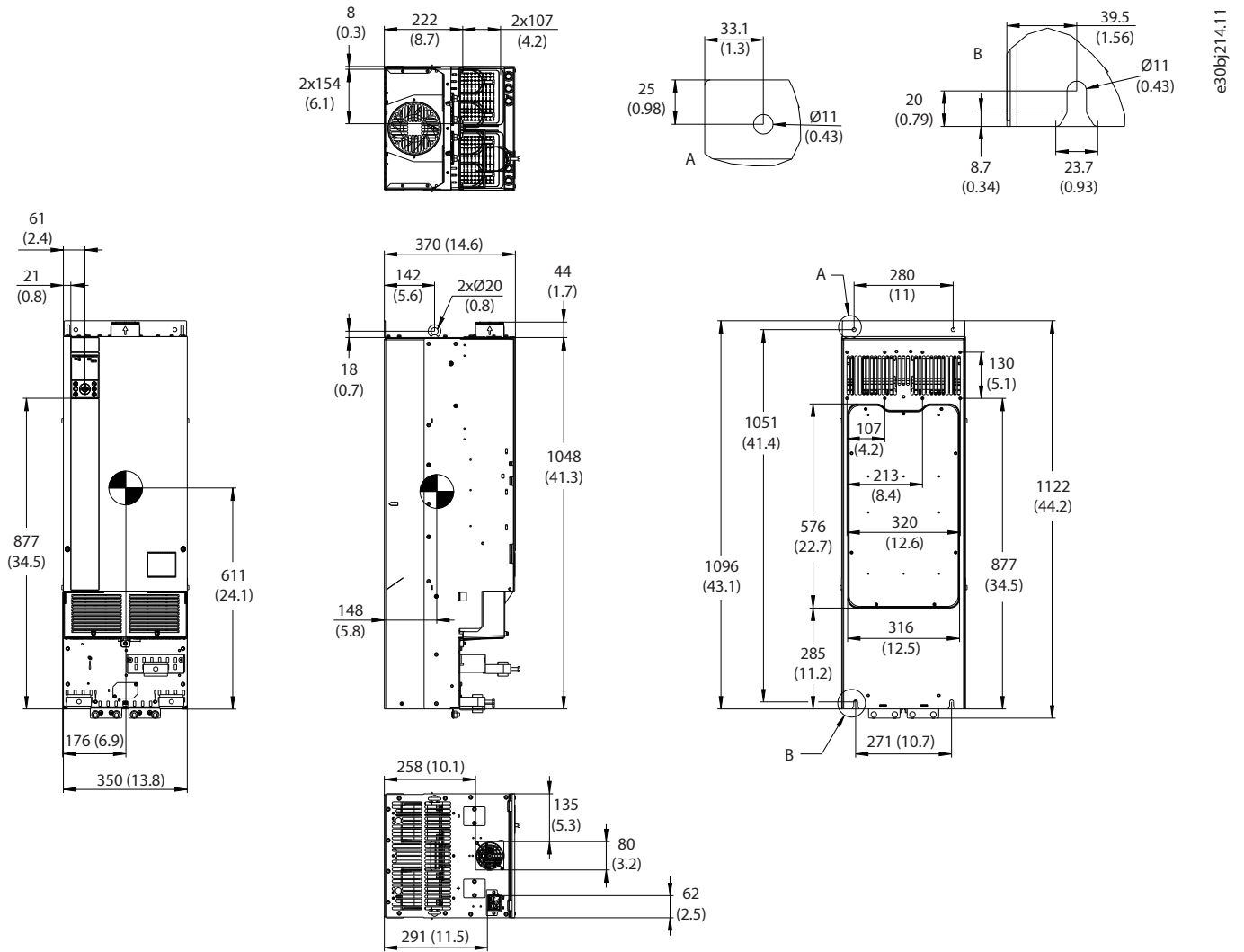
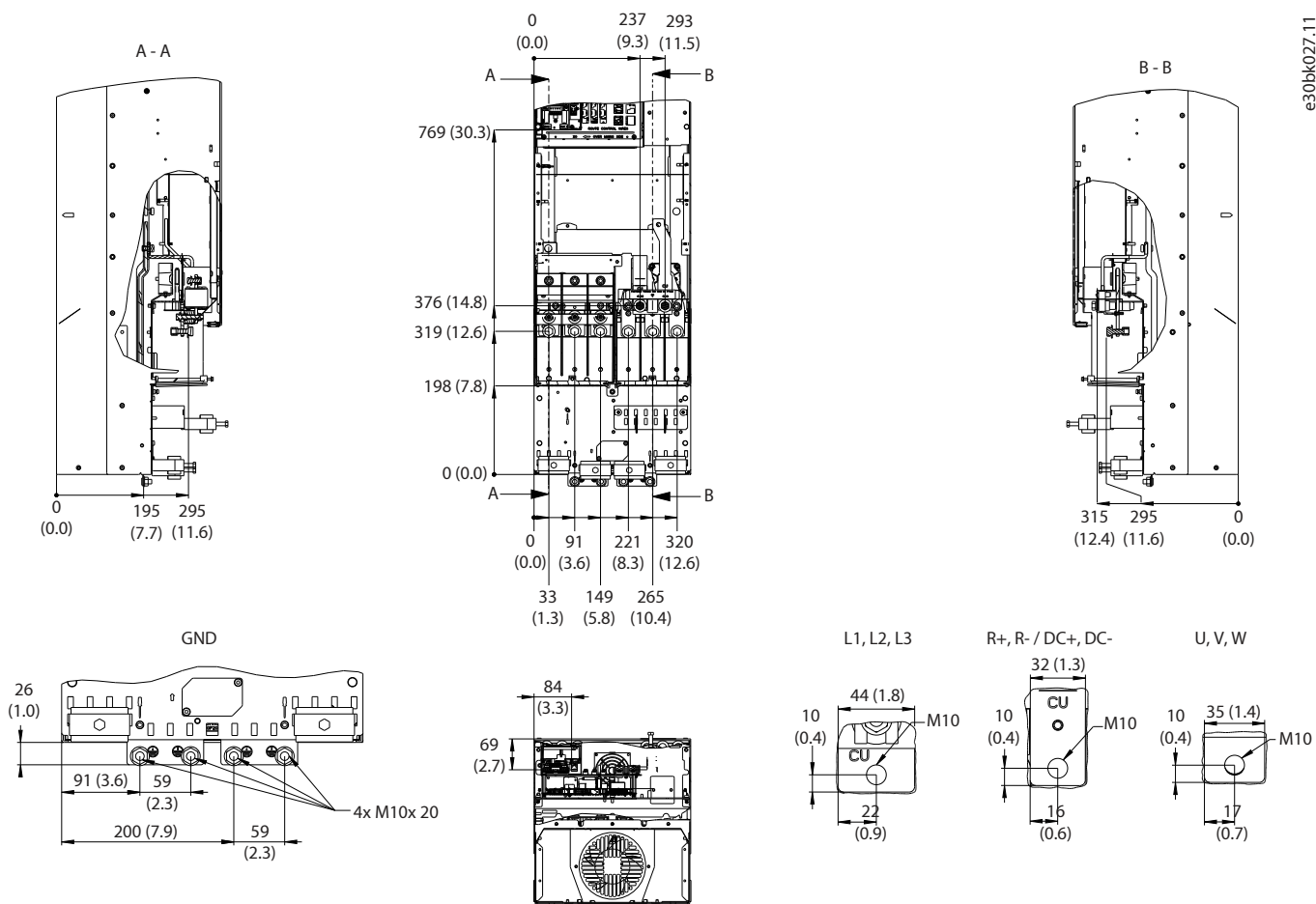

Figure 23: FA10 Exterior Dimensions

e30bj214.11



e30bk027.11

Figure 24: FA10 Terminal Dimensions

9.2.12 FA10b Dimensions

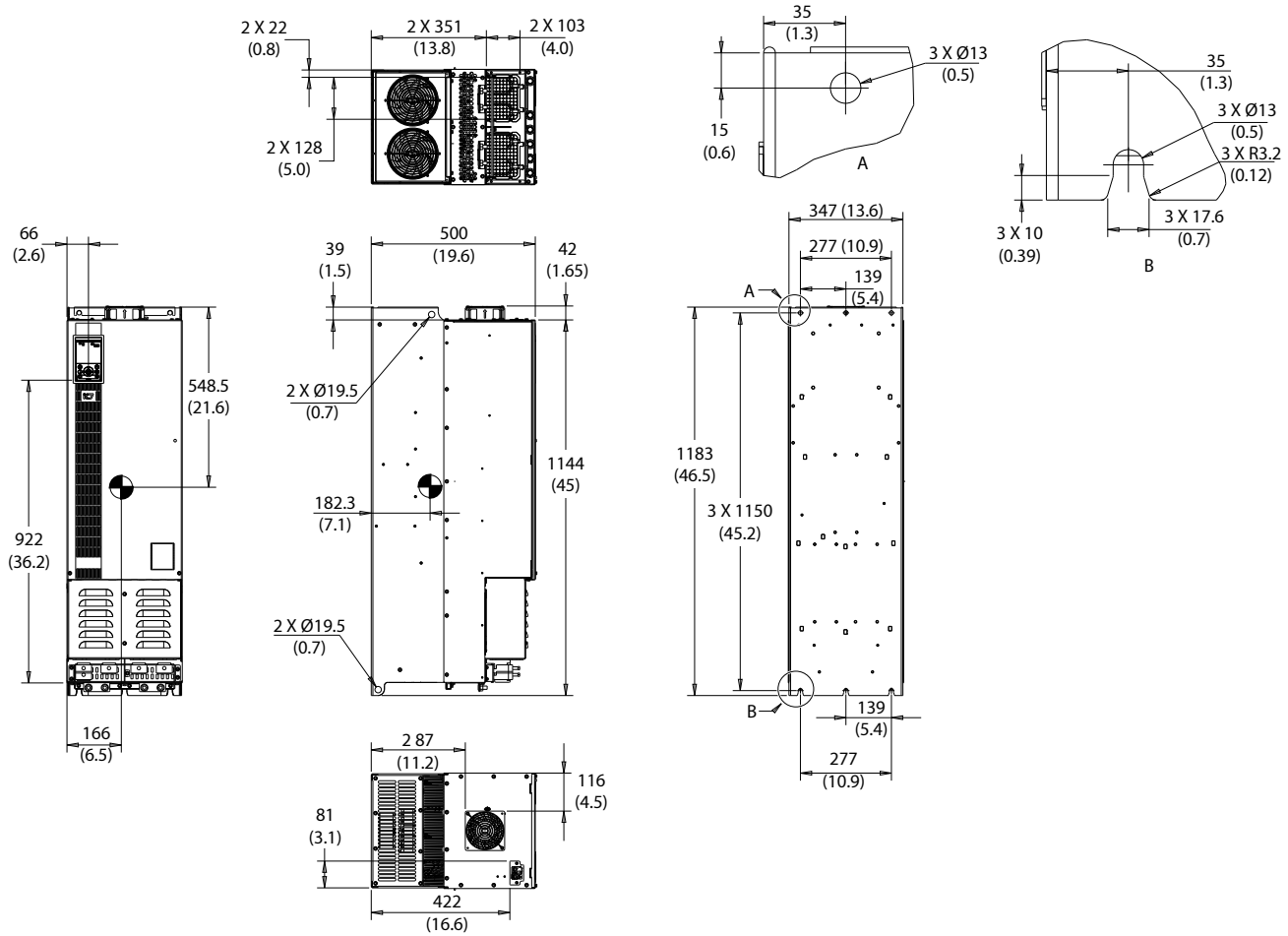

e30bm175.10

Figure 25: FA10b (Ultra Low-harmonic) Dimensions

9.2.13 FA11 Dimensions

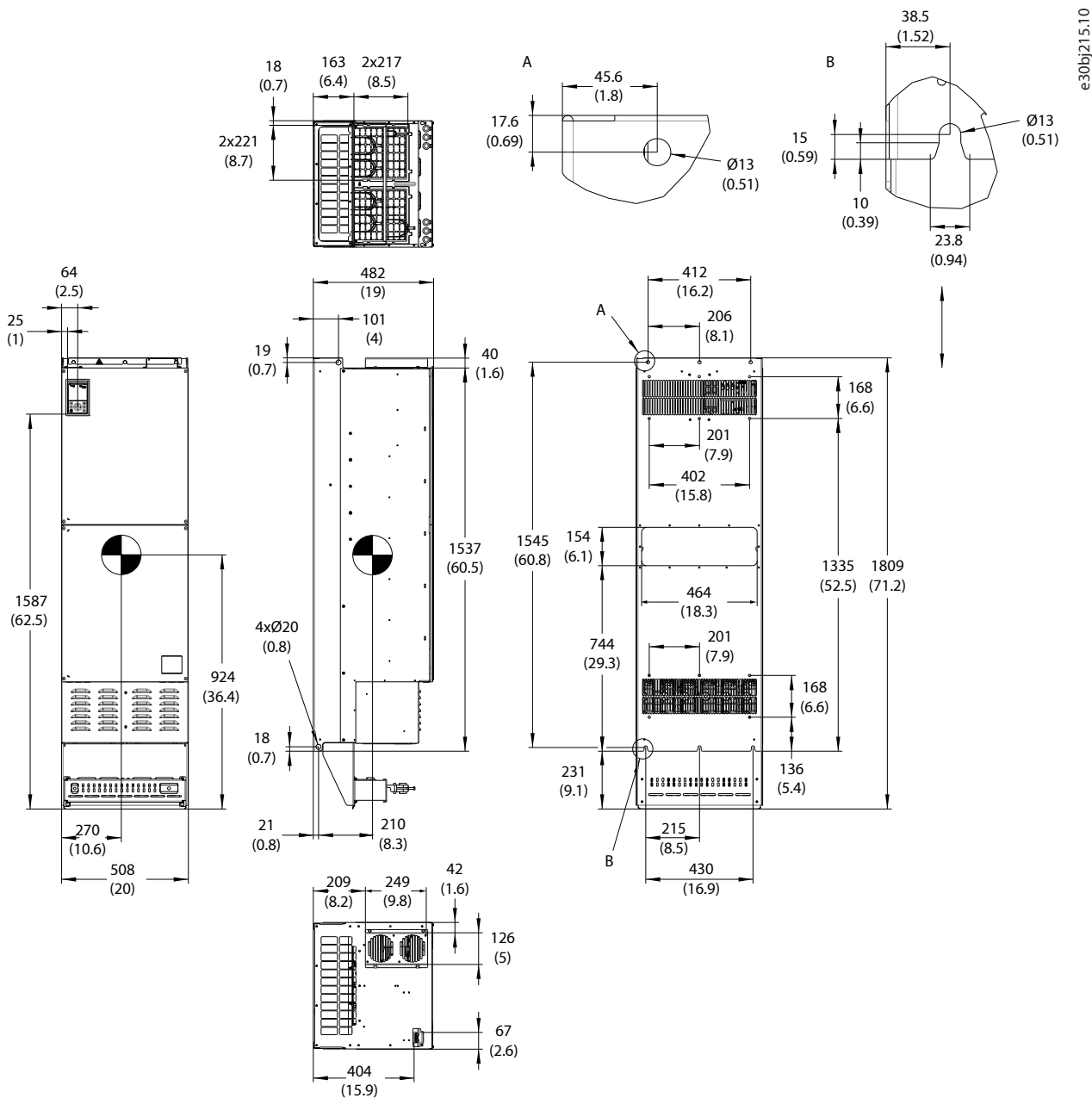
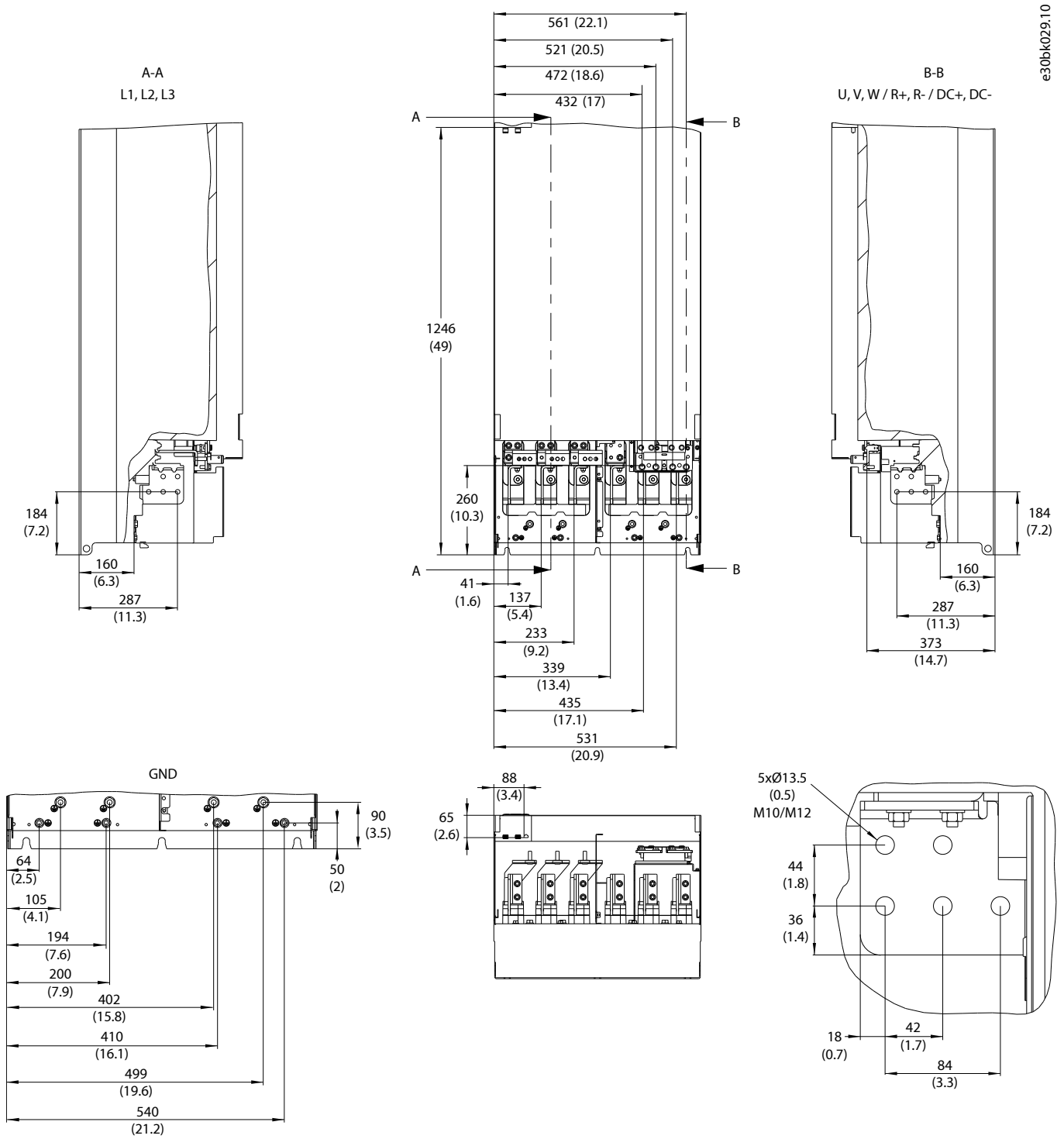
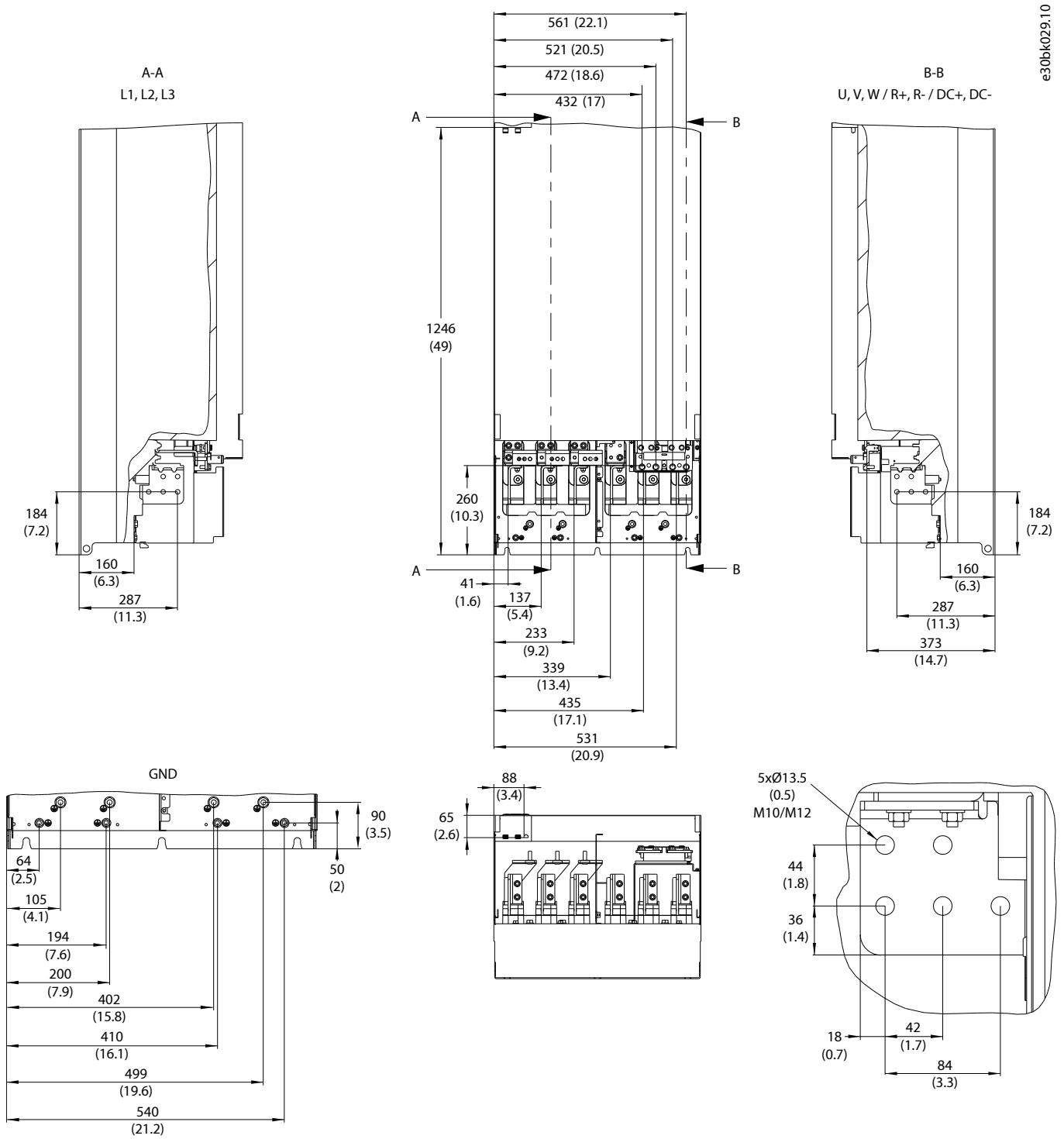

Figure 26: FA11 Exterior Dimensions



e30bk029;10

Figure 27: FA11 Terminal Dimensions



e30bk029;10

Figure 29: FA12 Terminal Dimensions

9.3 IP21/UL Type 1 Frames (FK03–FK12)

9.3.1 FK06 Dimensions

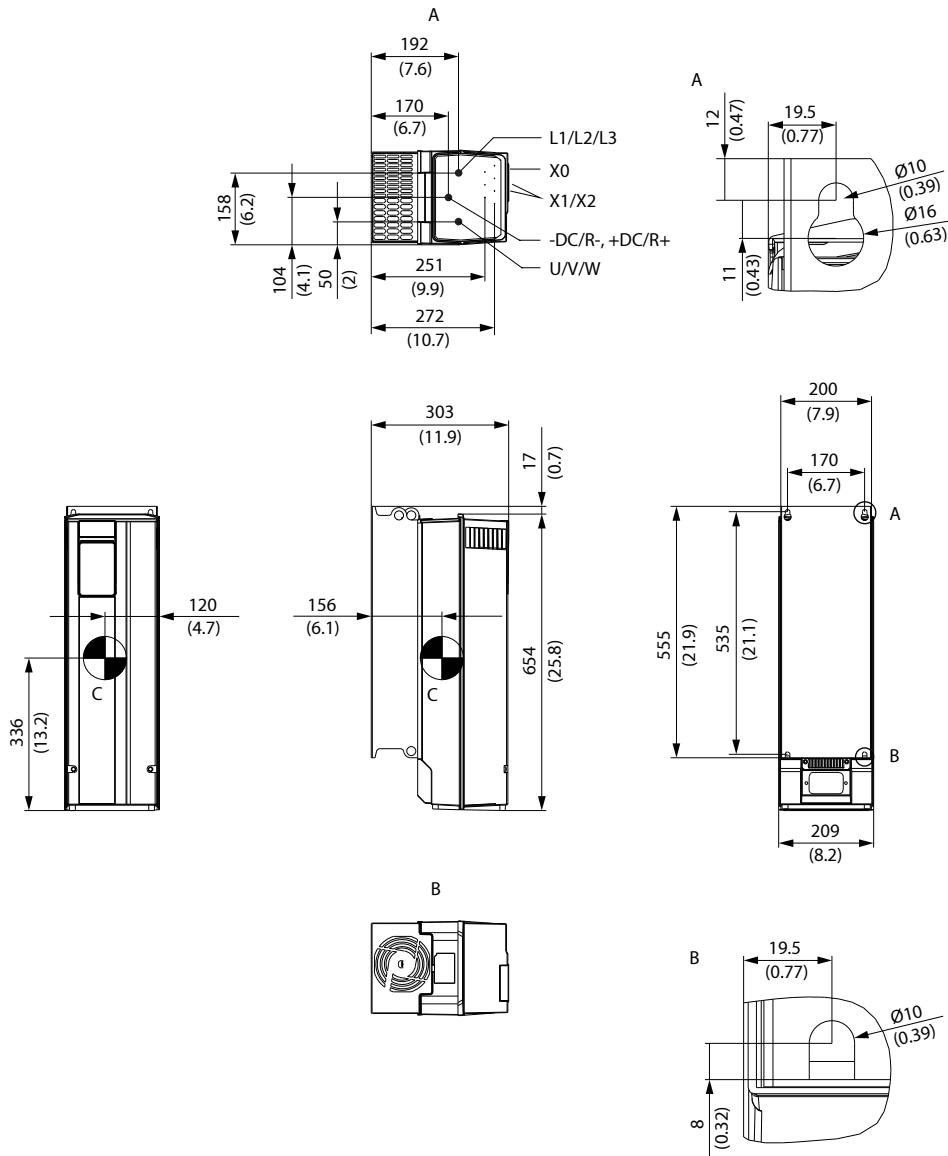

e30bj969.10

Figure 30: FK06 Dimensions

9.3.2 FK07 Dimensions

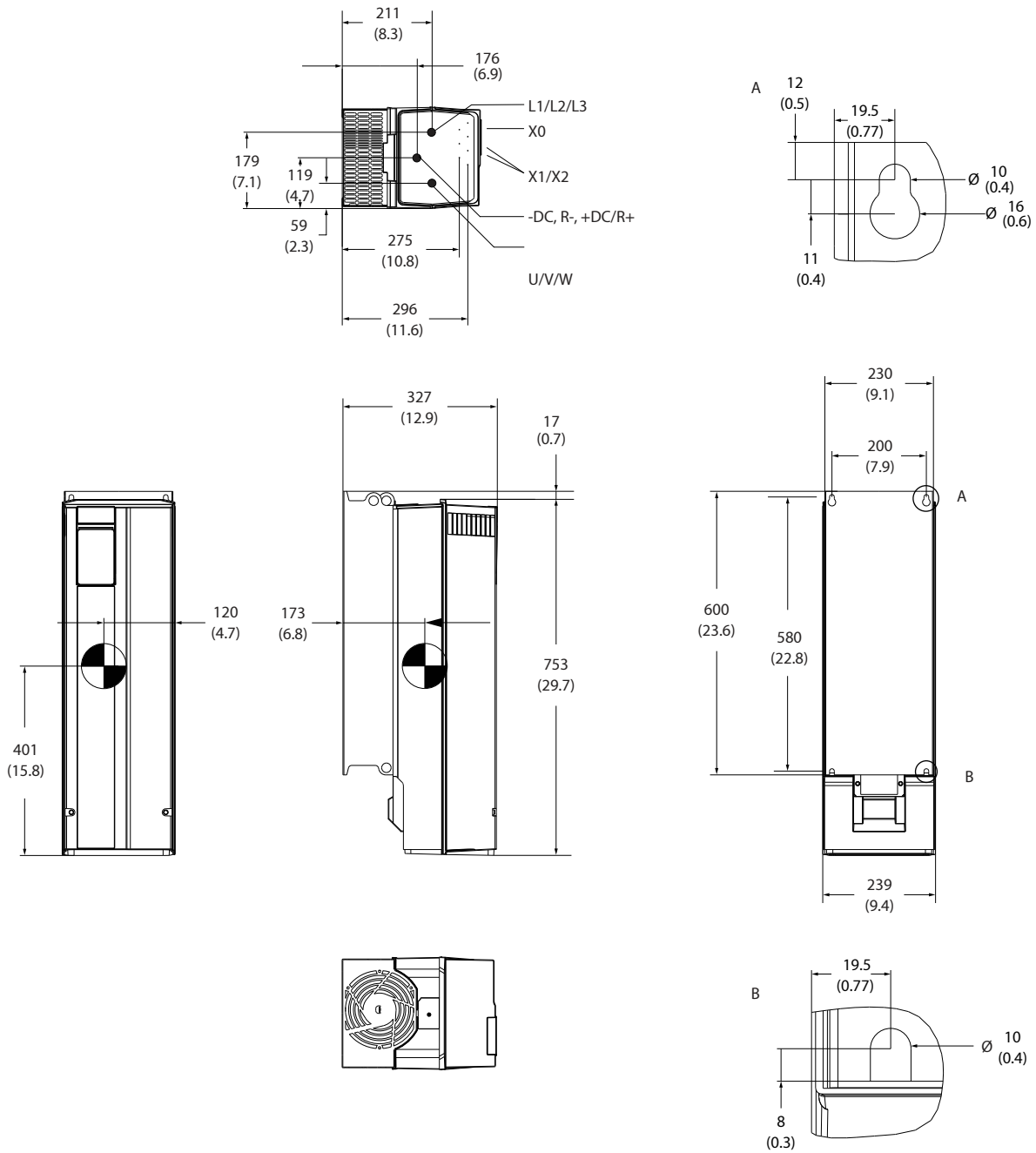

e30bi970.10

Figure 31: FK07 Dimensions

9.3.3 FK08 Dimensions

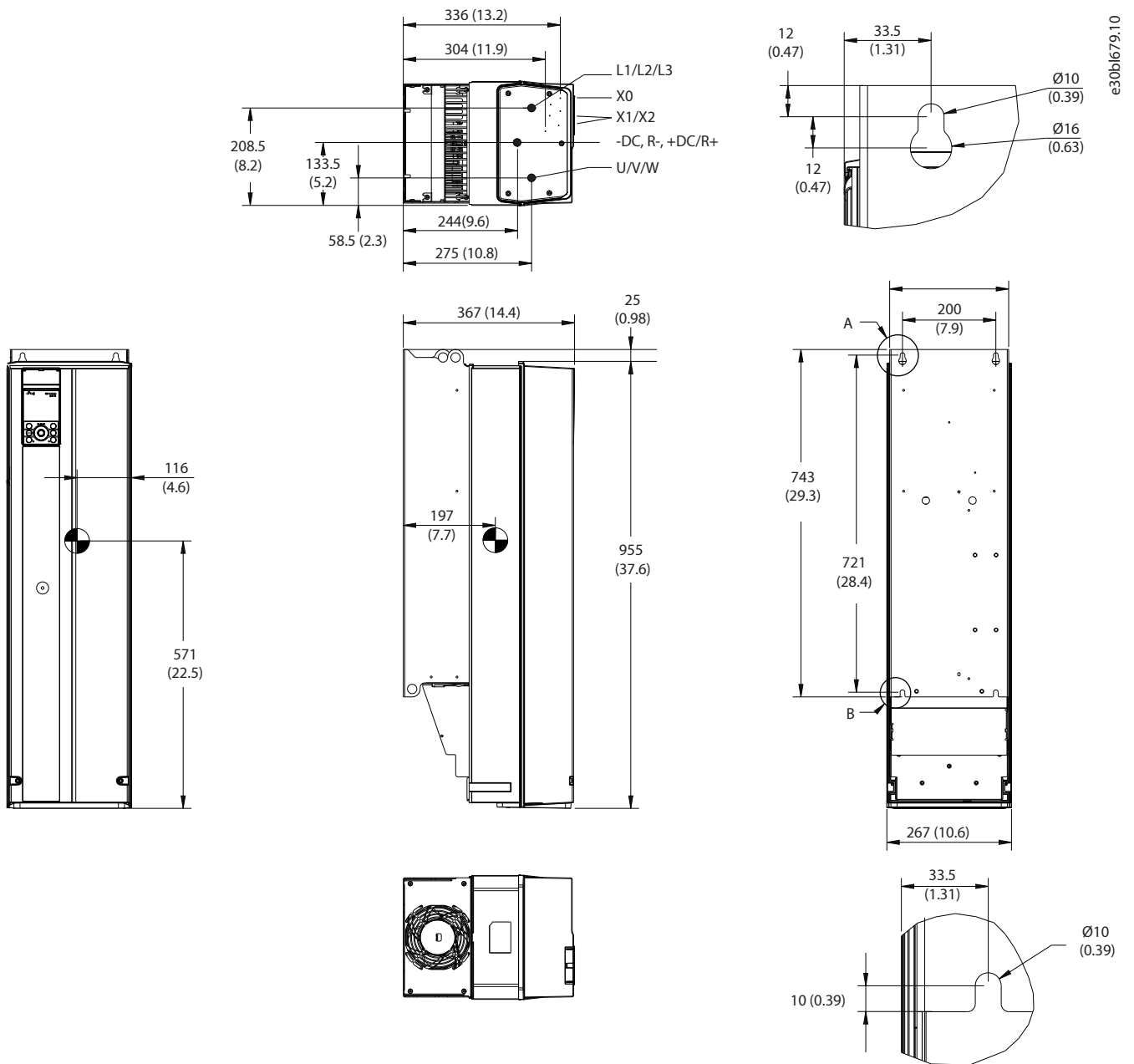

Figure 32: FK08 Dimensions

9.3.4 FK09a Dimensions

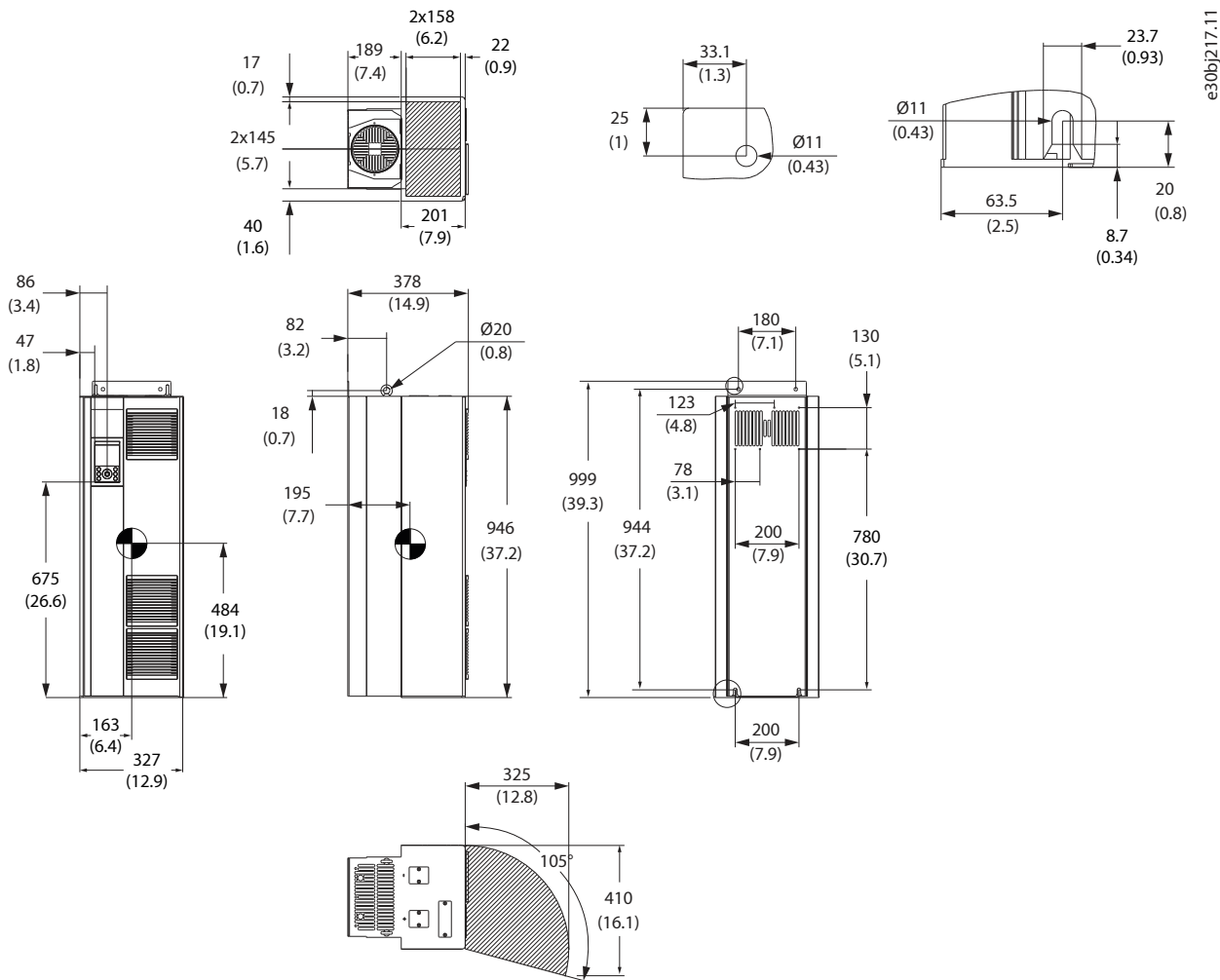

Figure 33: FK09a Dimensions

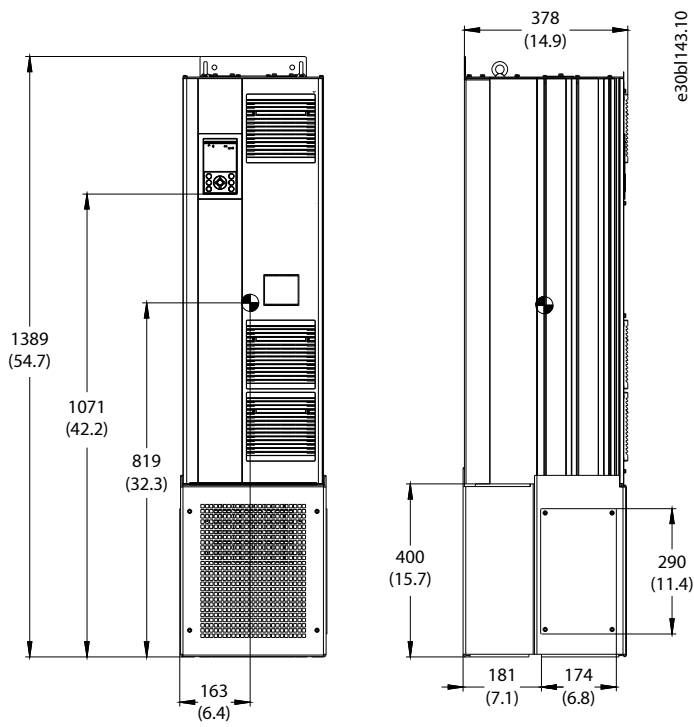

Figure 34: FK09a Dimensions with Optional Pedestal

9.3.5 FK09c Dimensions

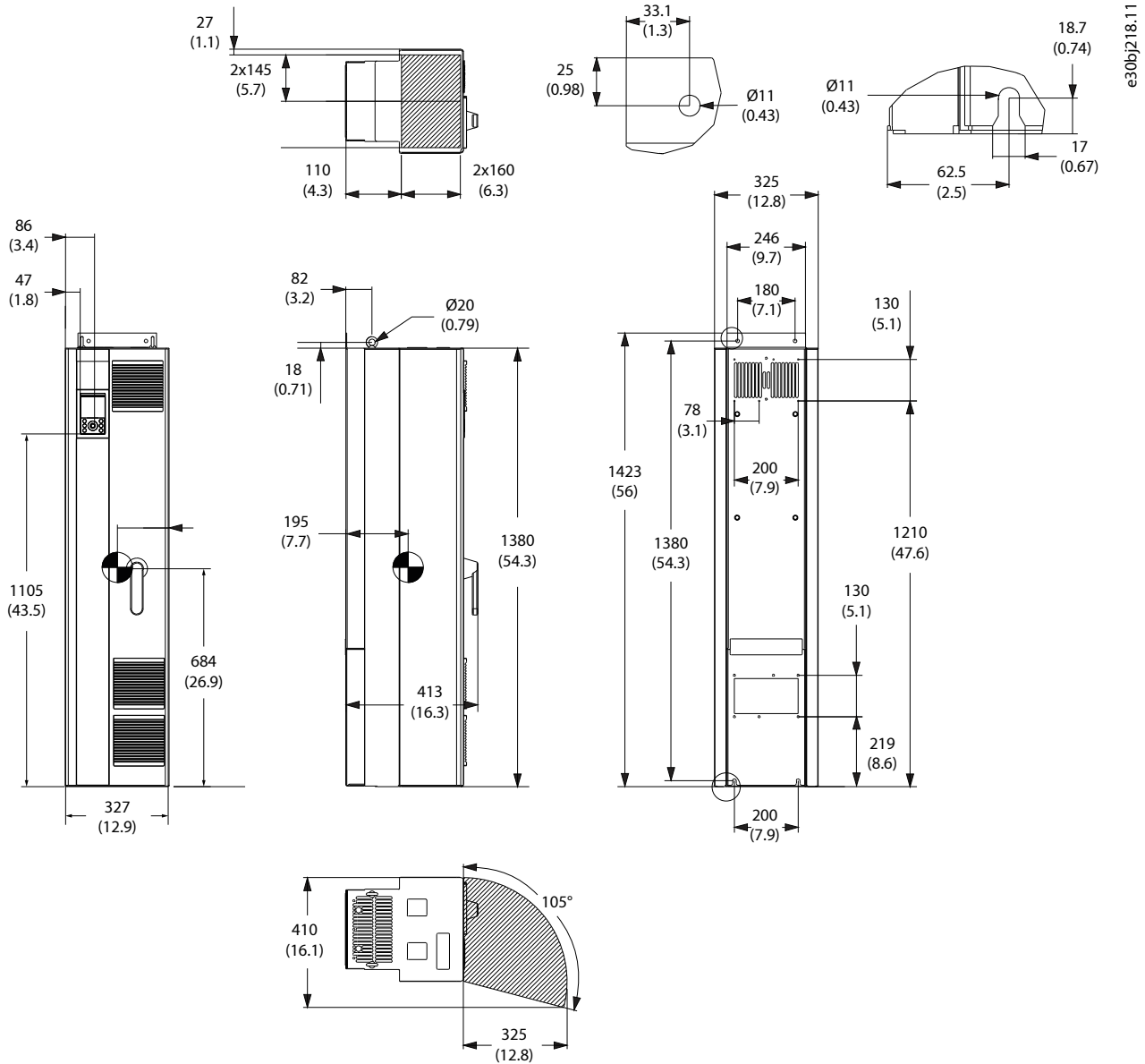

Figure 35: FK09c Dimensions

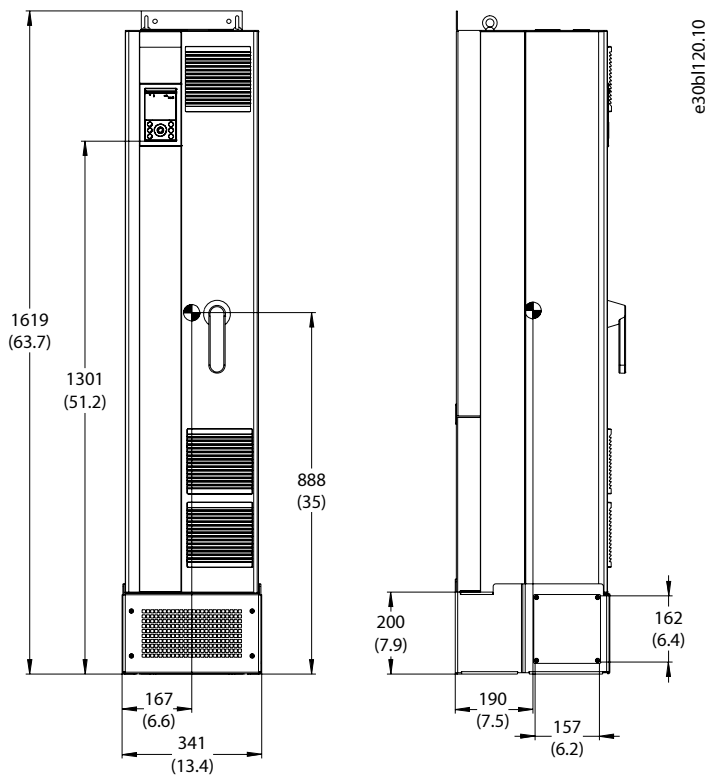
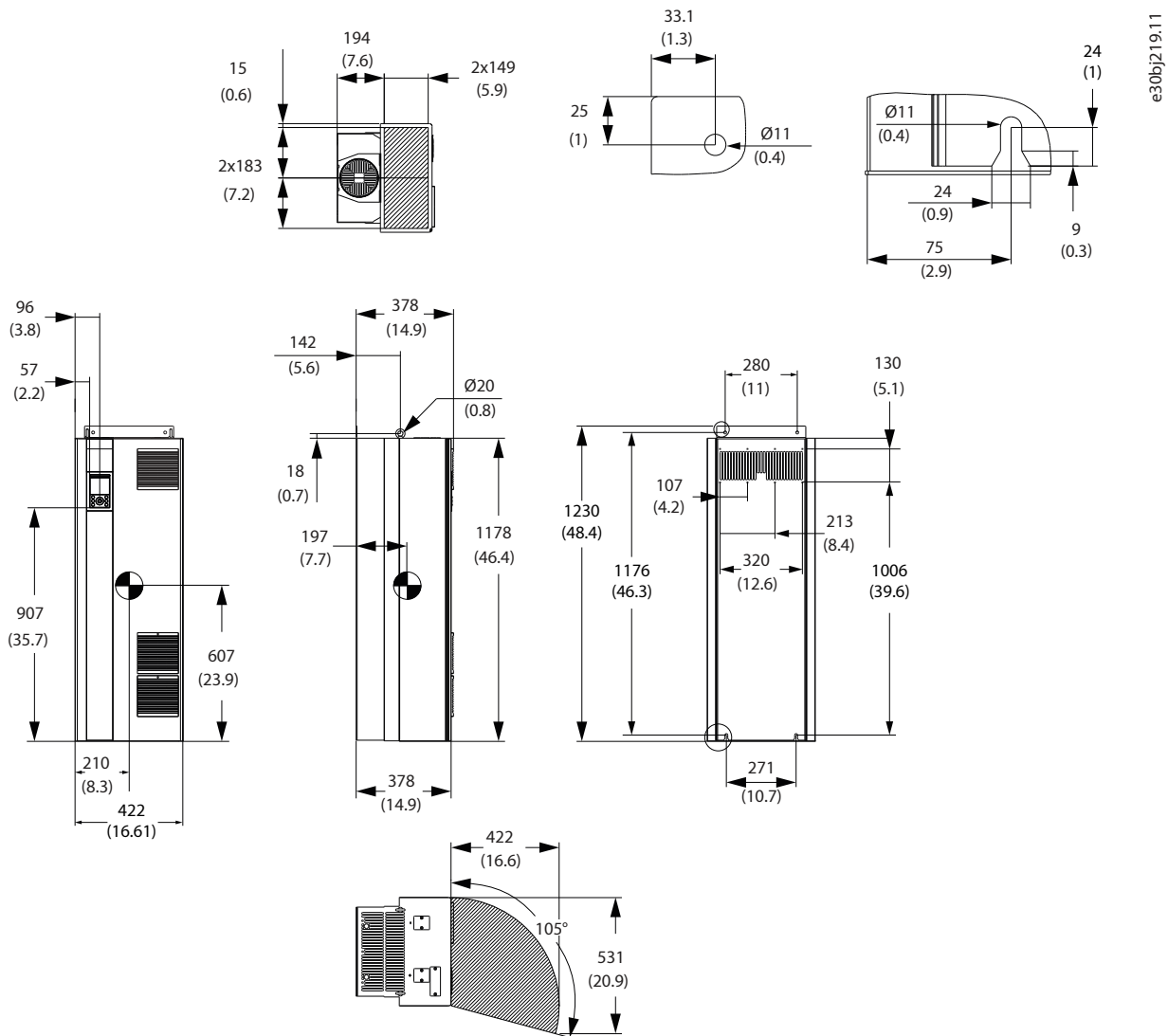

Figure 36: FK09c Dimensions with Optional Pedestal

9.3.6 FK10a Dimensions



e30bj219.11

Figure 37: FK10a Dimensions

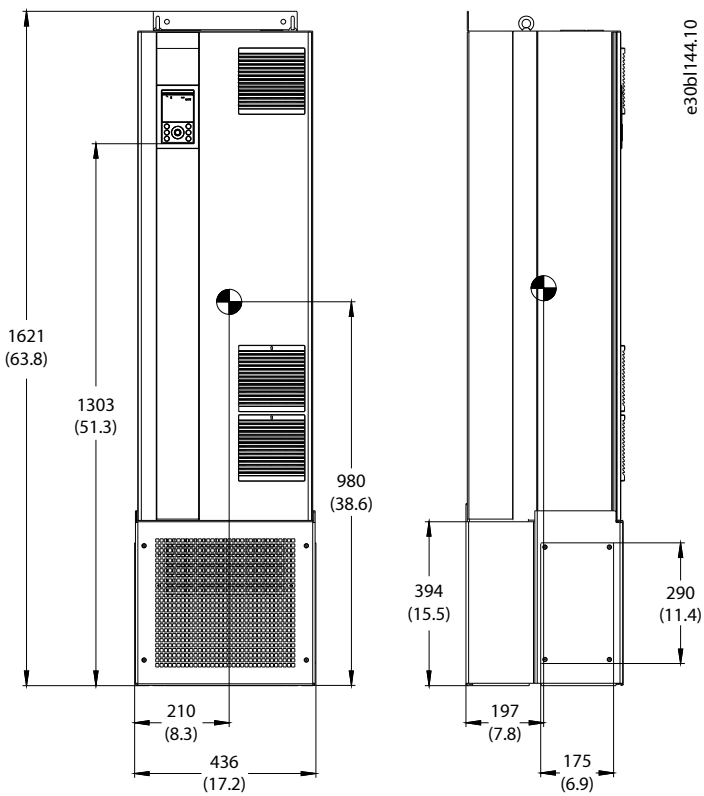
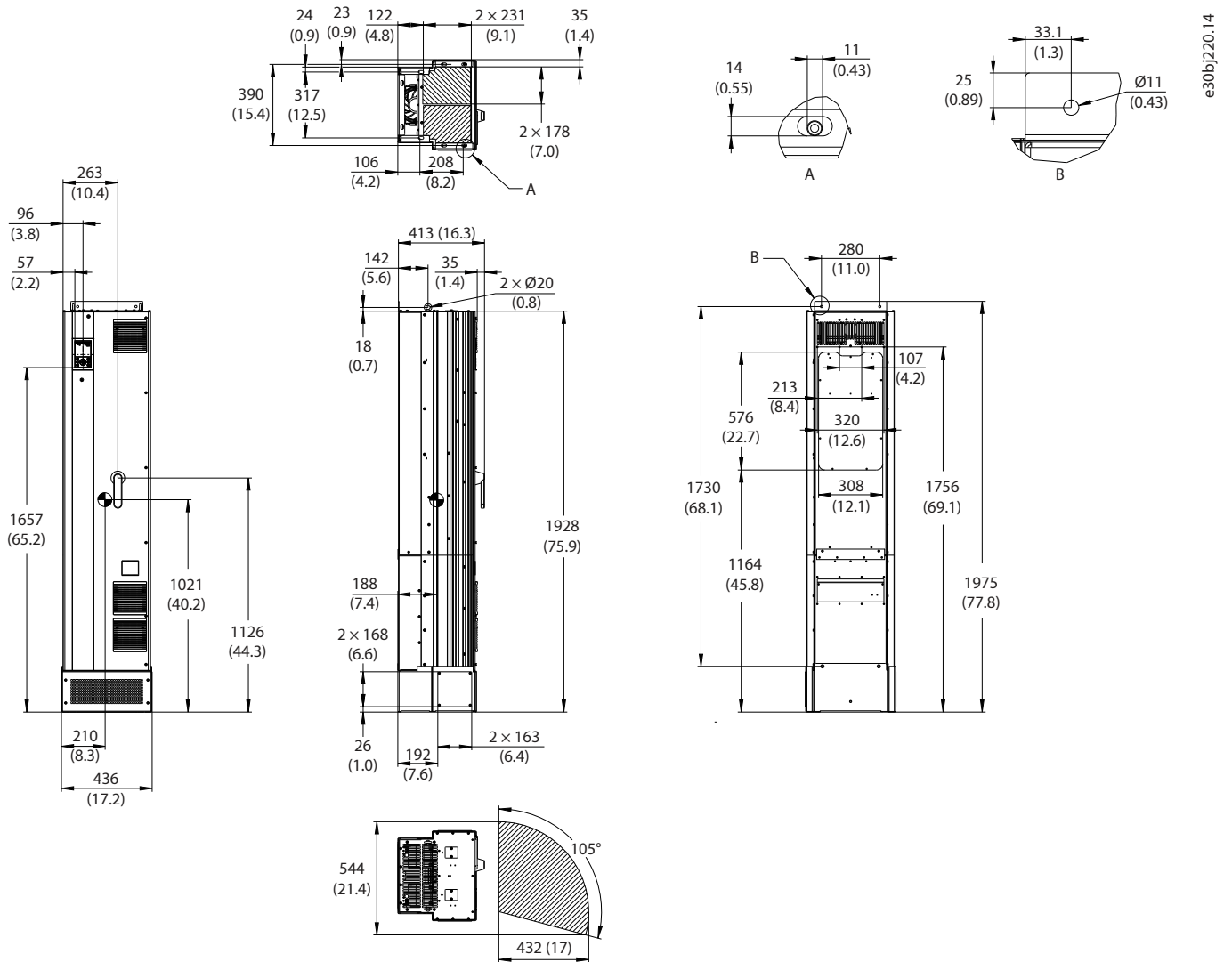

Figure 38: FK10a Dimensions with Optional Pedestal

9.3.7 FK10b Dimensions

Contact Danfoss.

9.3.8 FK10c Dimensions



e30bj220.14

Figure 39: FK10c Dimensions

9.3.10 FK12 Dimensions

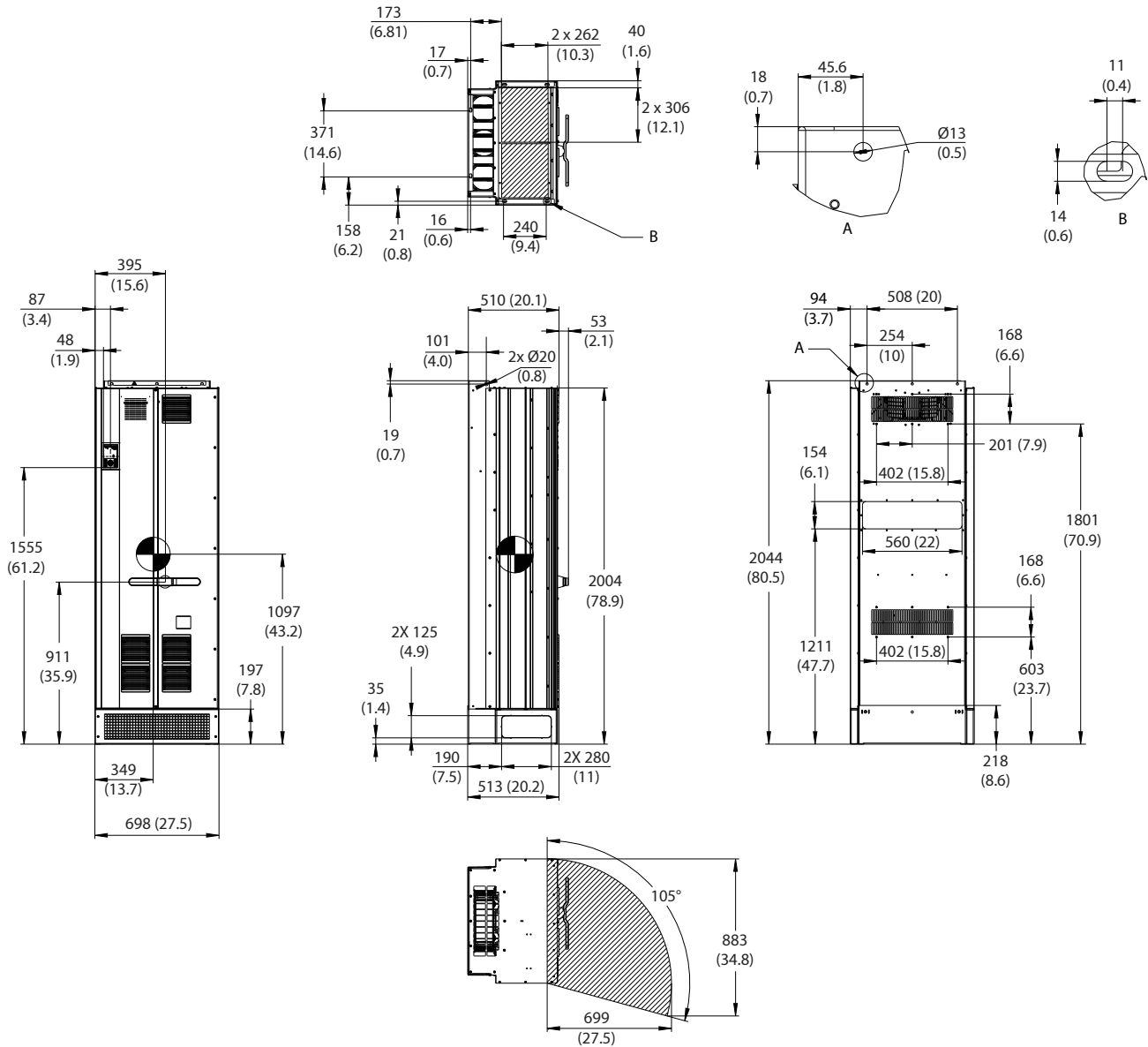

e30bj222.12

Figure 41: FK12 Dimensions

9.4 IP54/IP55/UL Type 12 Frames (FB03–FB12)

9.4.1 FB06 Dimensions

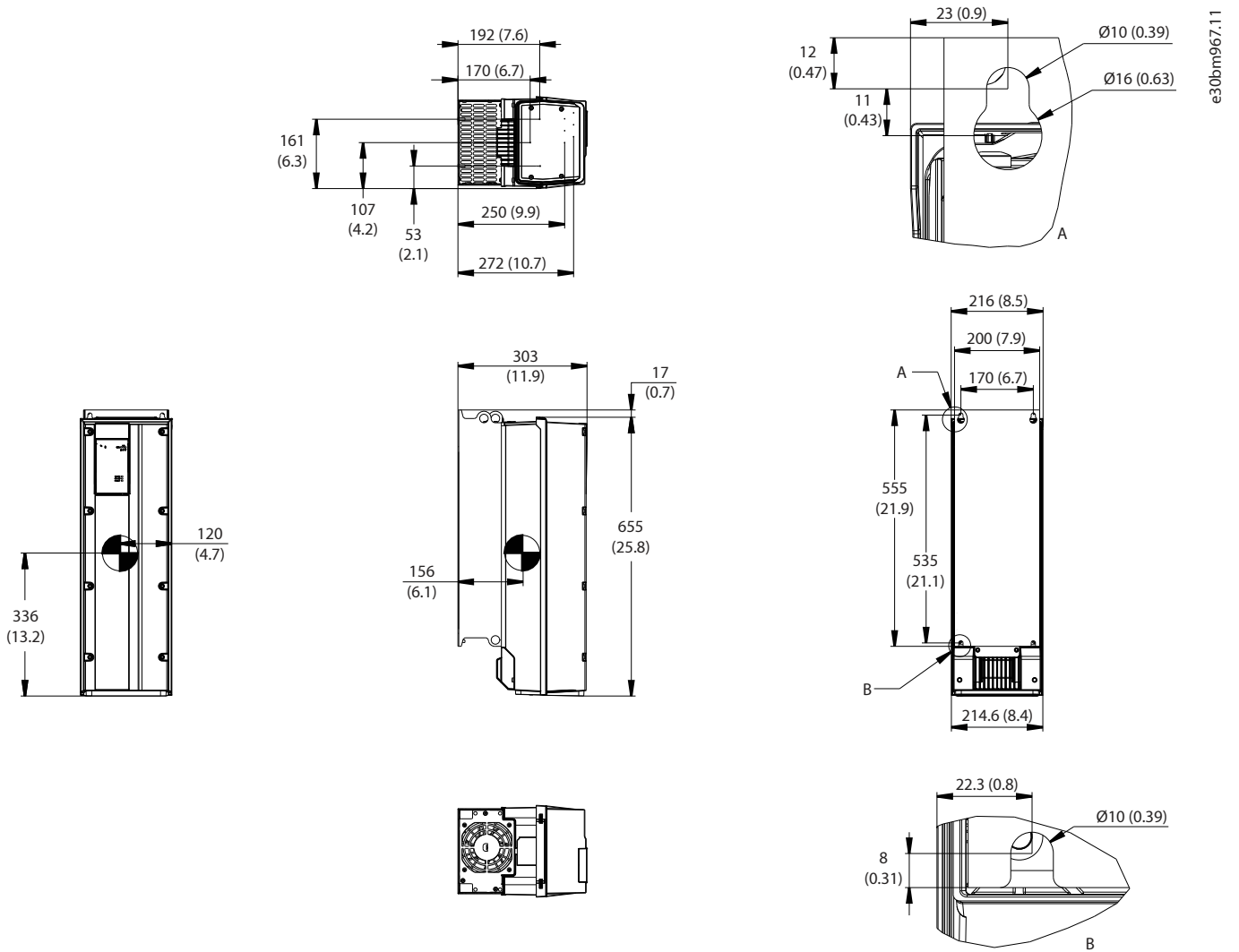
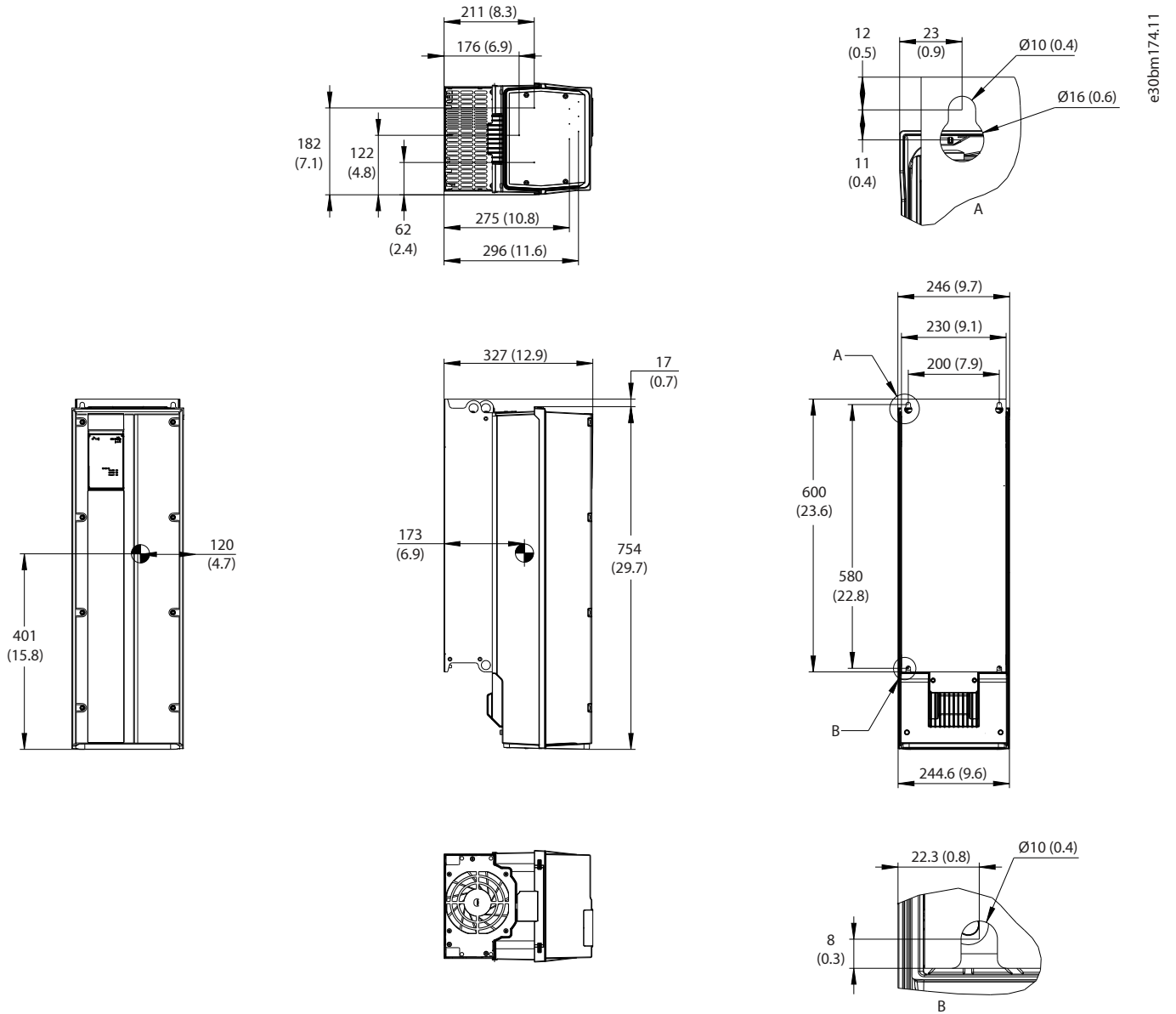

Figure 42: FB06 Dimensions

9.4.2 FB07 Dimensions



e30bm174.11

Figure 43: FB07 Dimensions

9.4.3 FB08 Dimensions

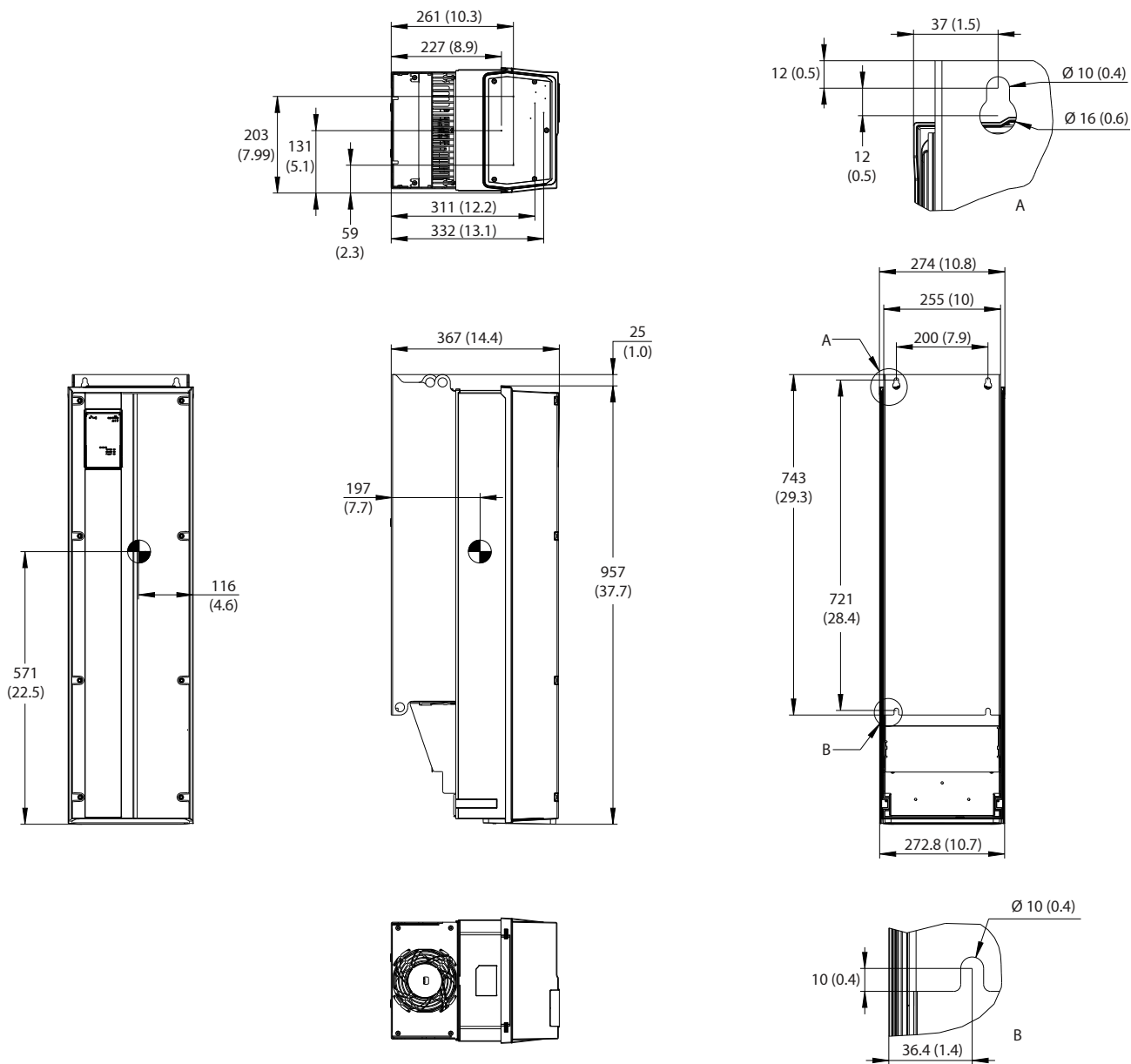

e30bm968.11

Figure 44: FB08 Dimensions

9.4.4 FB09a Dimensions

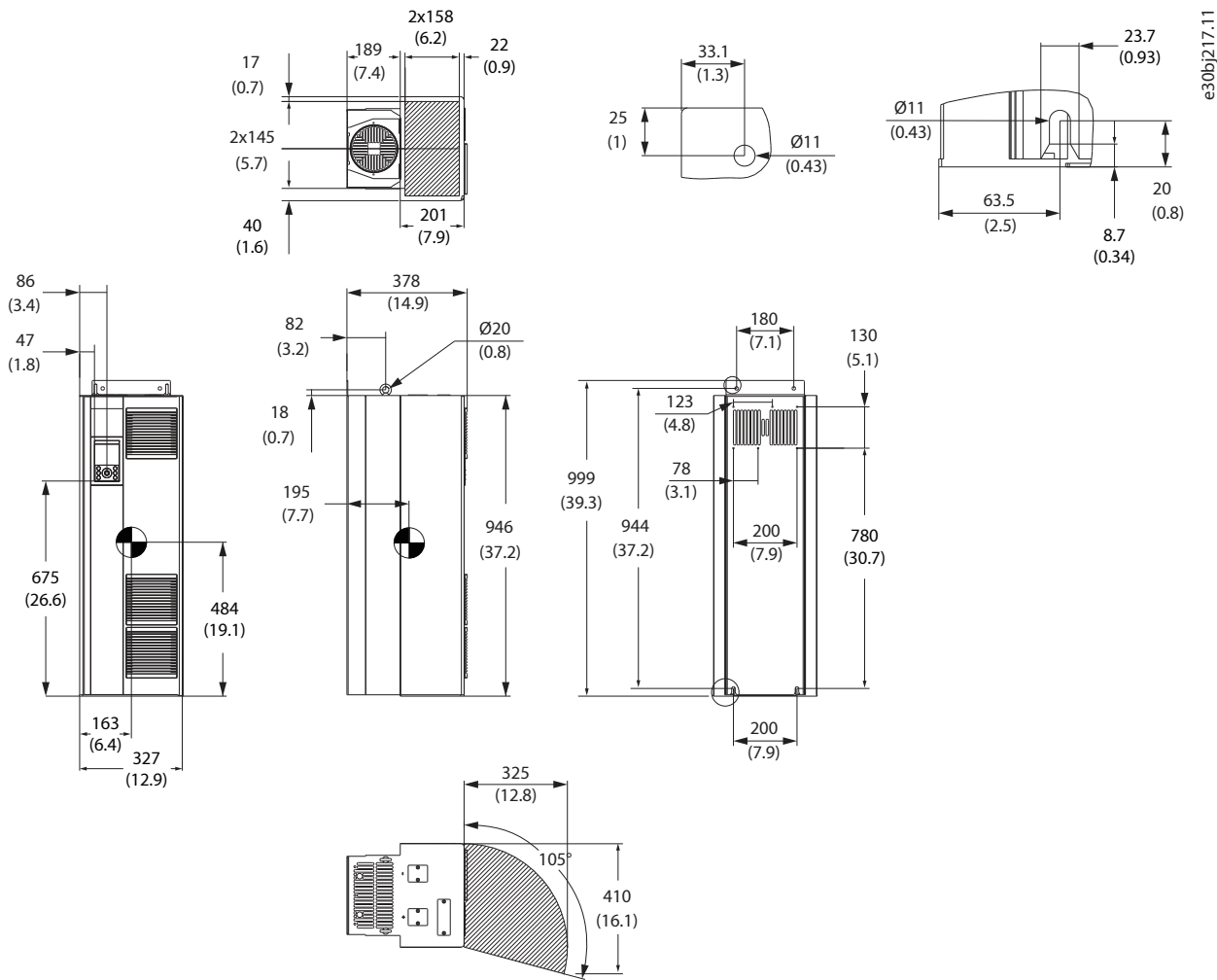

Figure 45: FB09a Dimensions

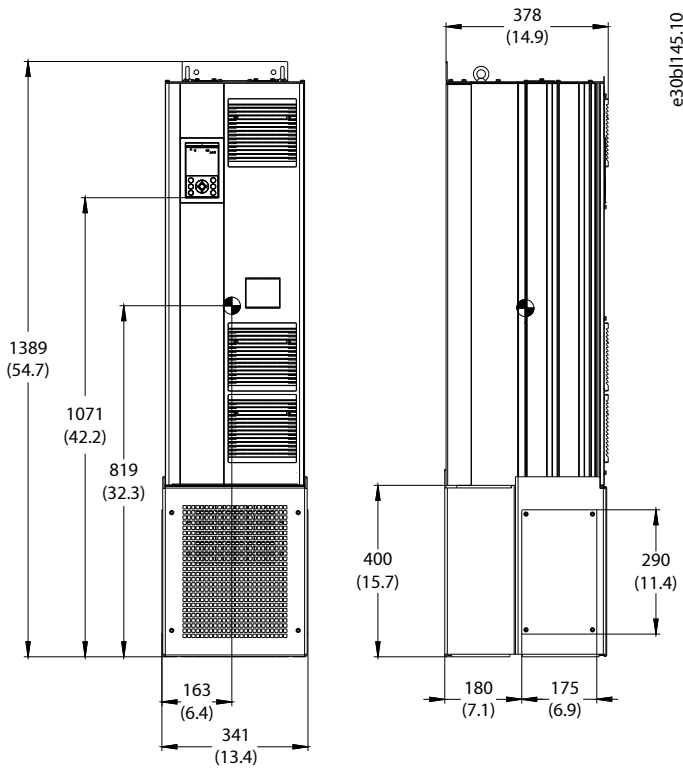

Figure 46: FB09a Dimensions with Optional Pedestal

9.4.5 FB09c Dimensions

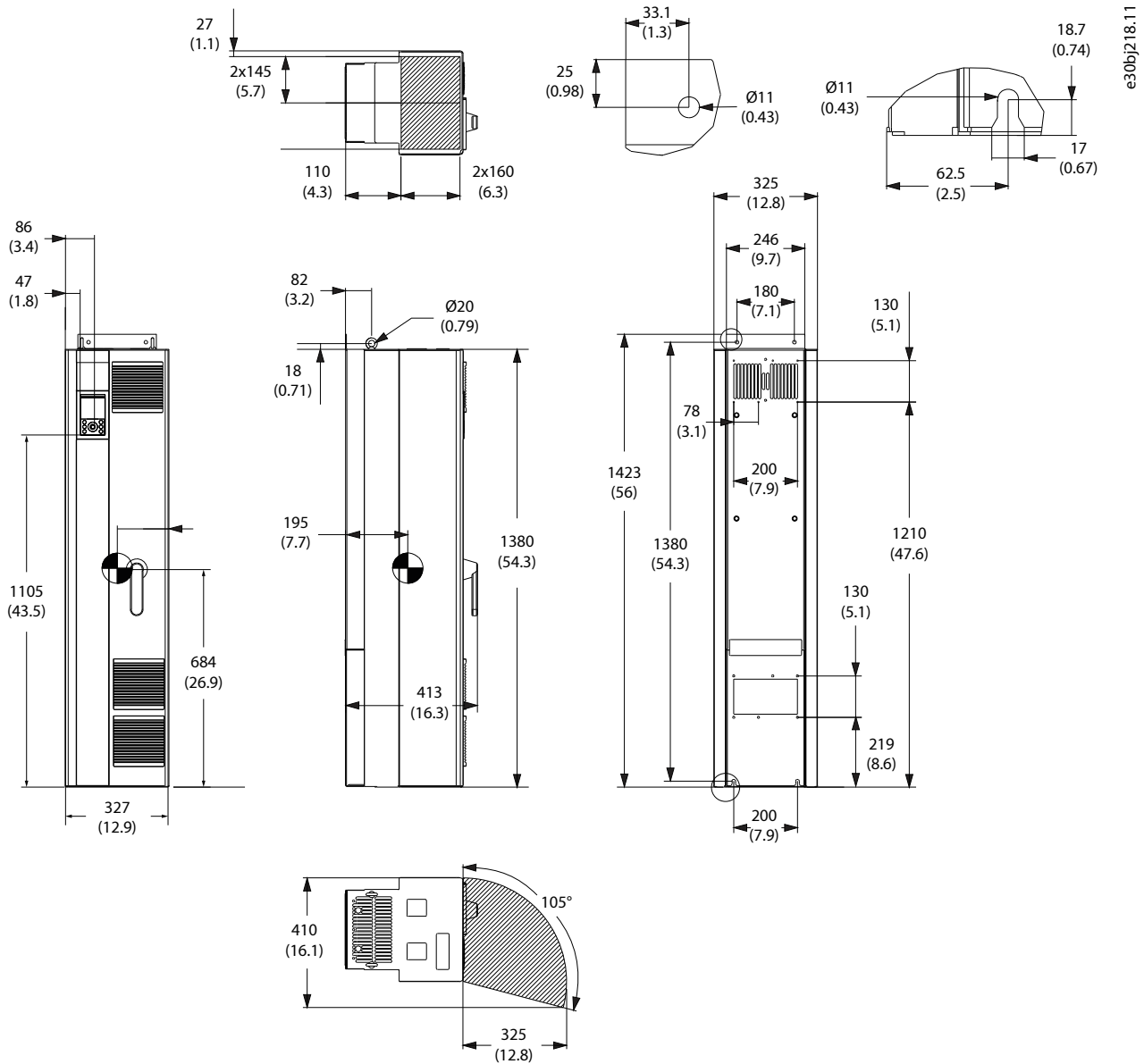

Figure 47: FB09c Dimensions

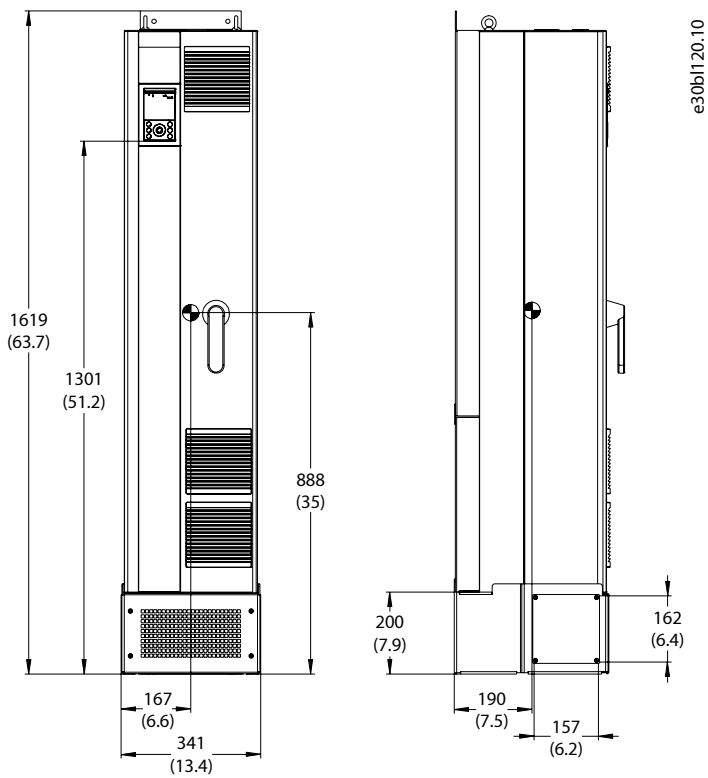
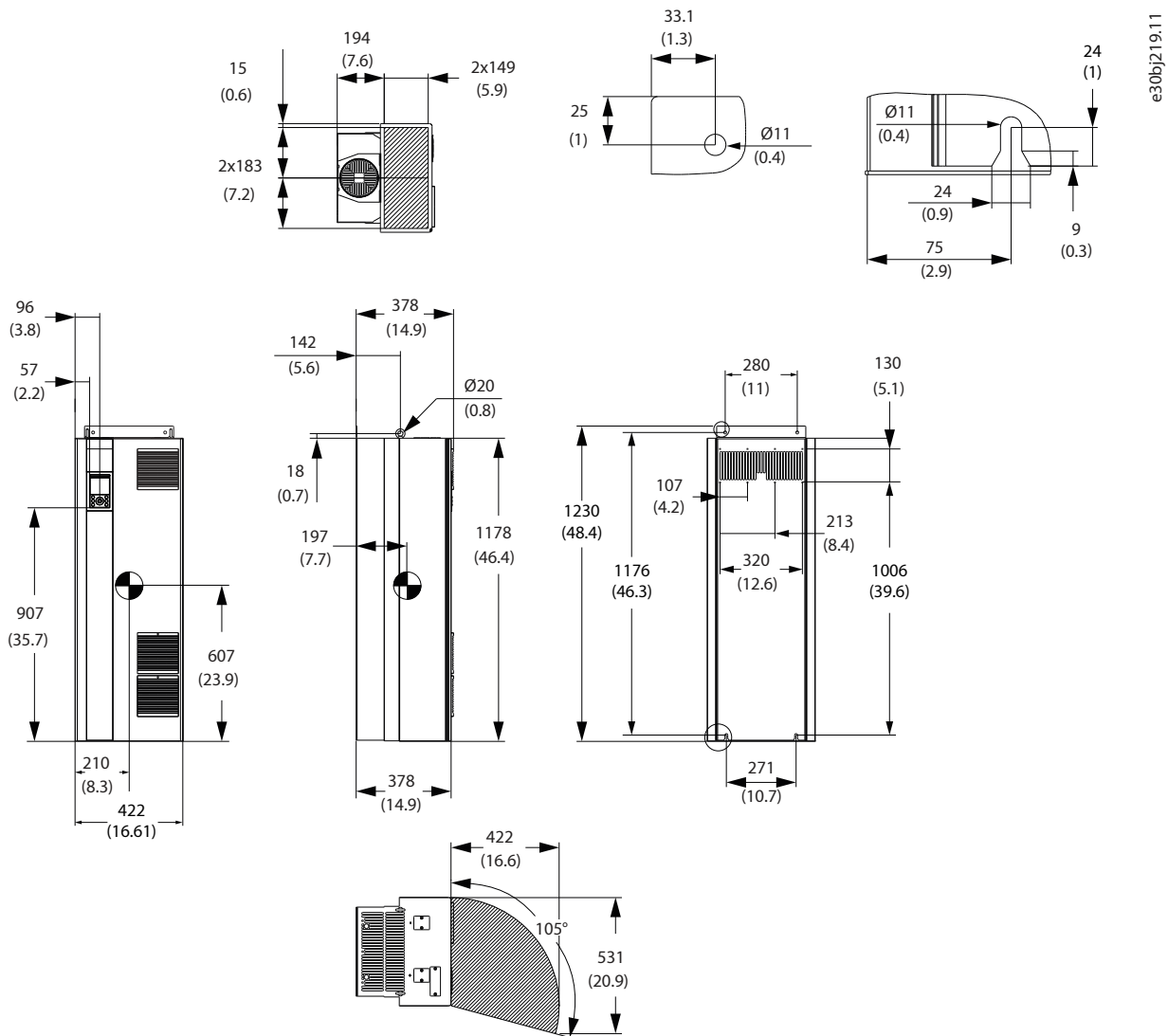

Figure 48: FB09c Dimensions with Optional Pedestal

9.4.6 FB10a Dimensions



e30bj219.11

Figure 49: FB10a Dimensions

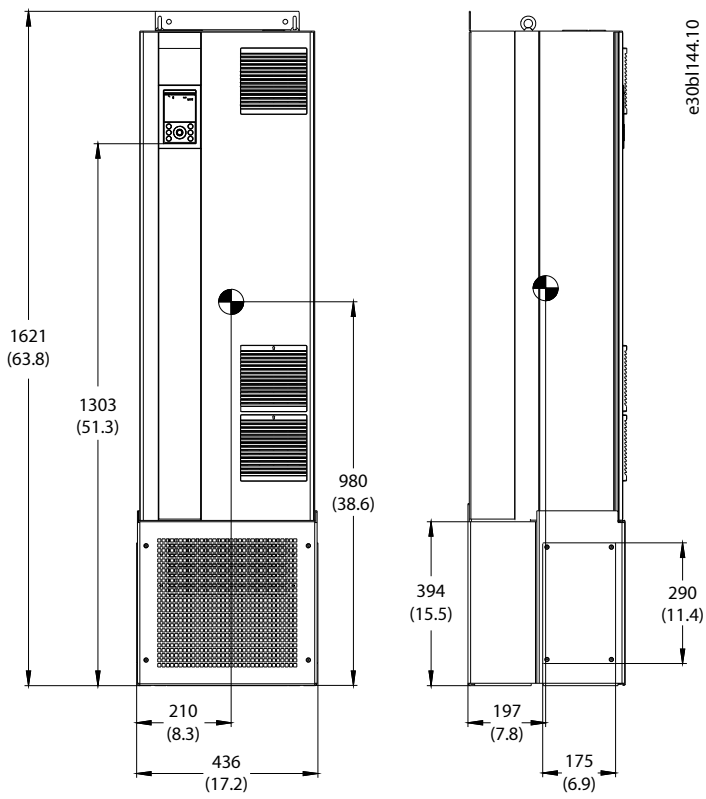
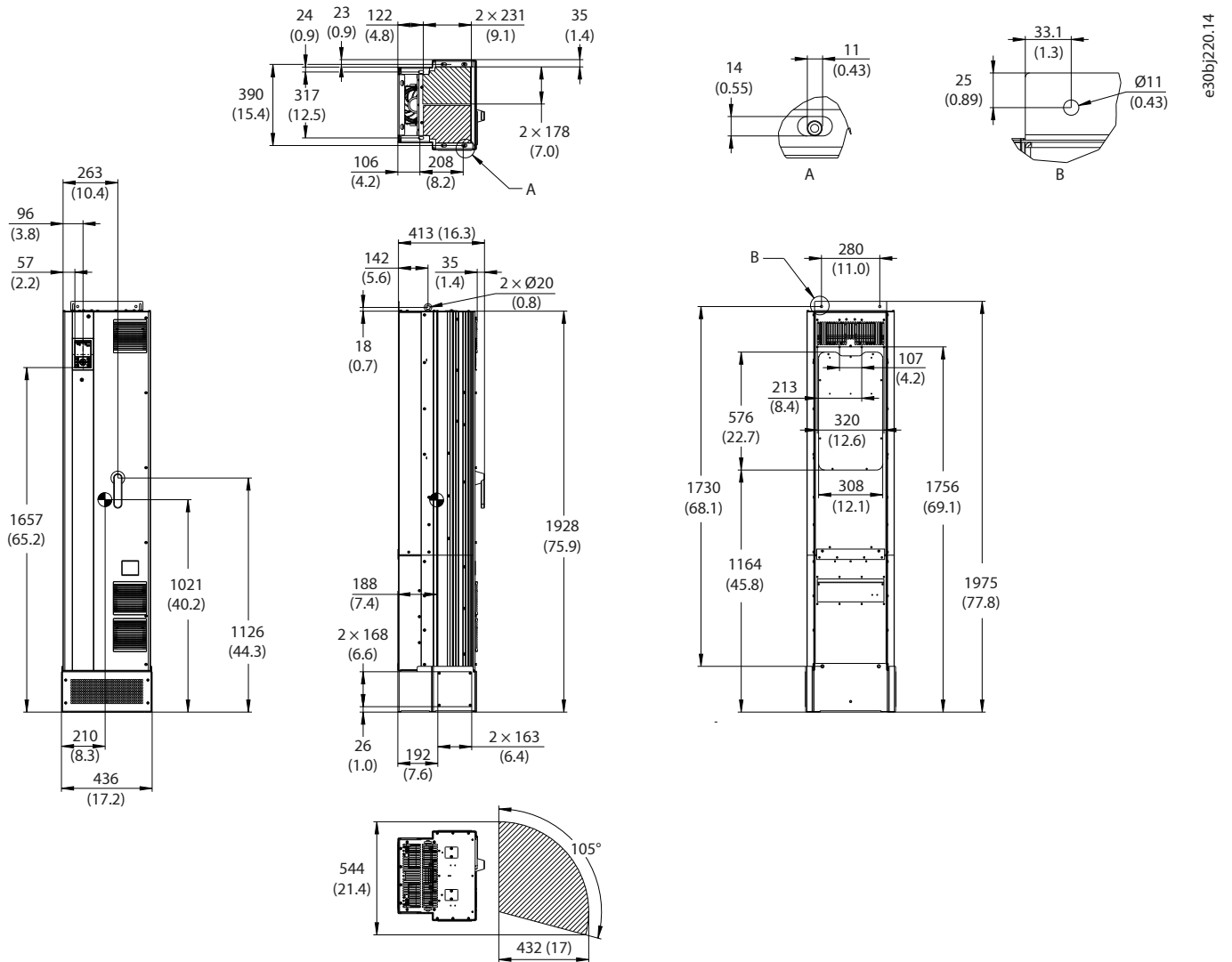

Figure 50: FB10a Dimensions with Optional Pedestal

9.4.7 FB10b Dimensions

Contact Danfoss.

9.4.8 FB10c Dimensions



e30bj20.14

Figure 51: FB10c Dimensions

9.4.9 FB11 Dimensions

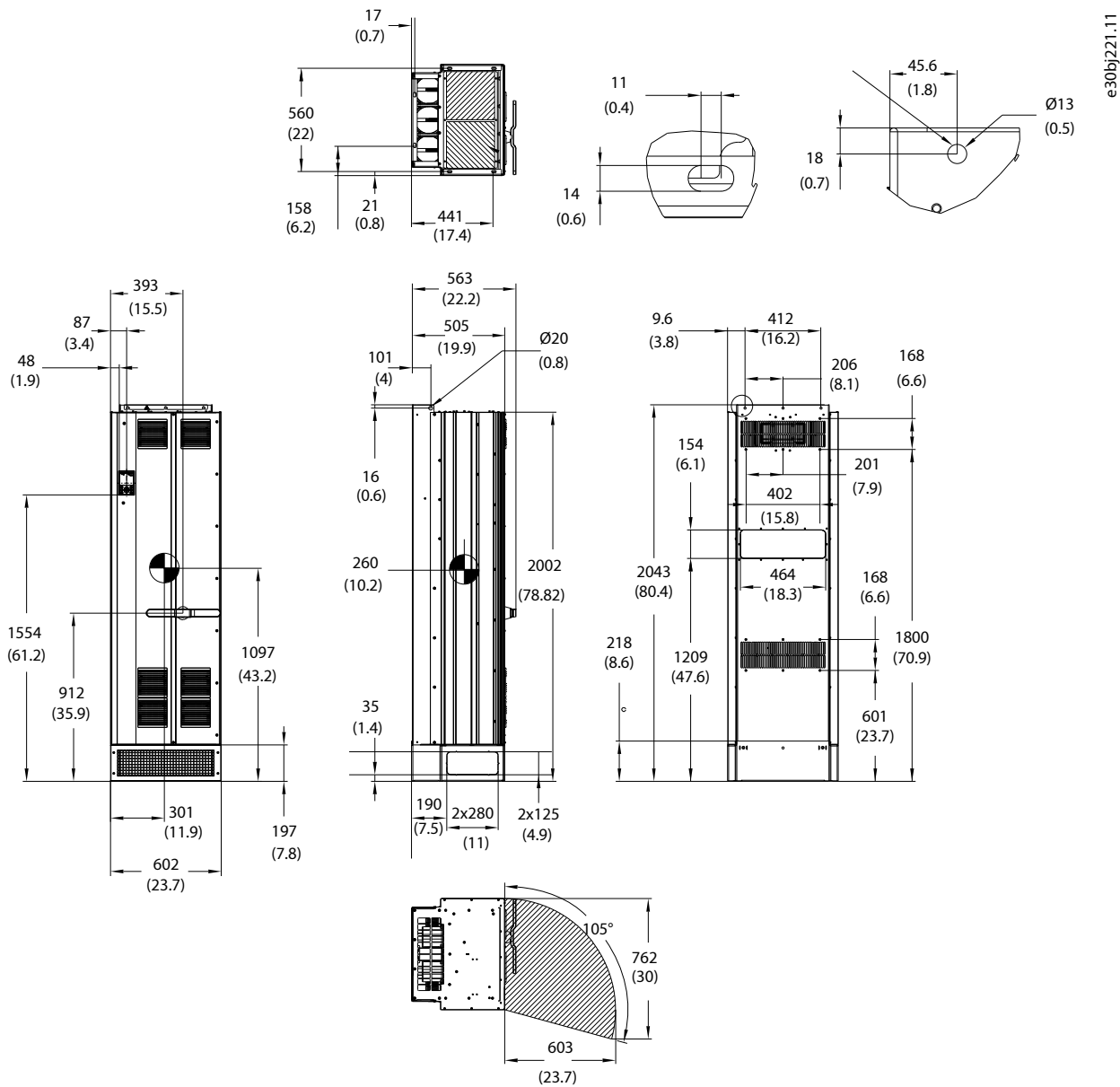

e:30bj221.11

Figure 52: FB11 Dimensions

9.4.10 FB12 Dimensions

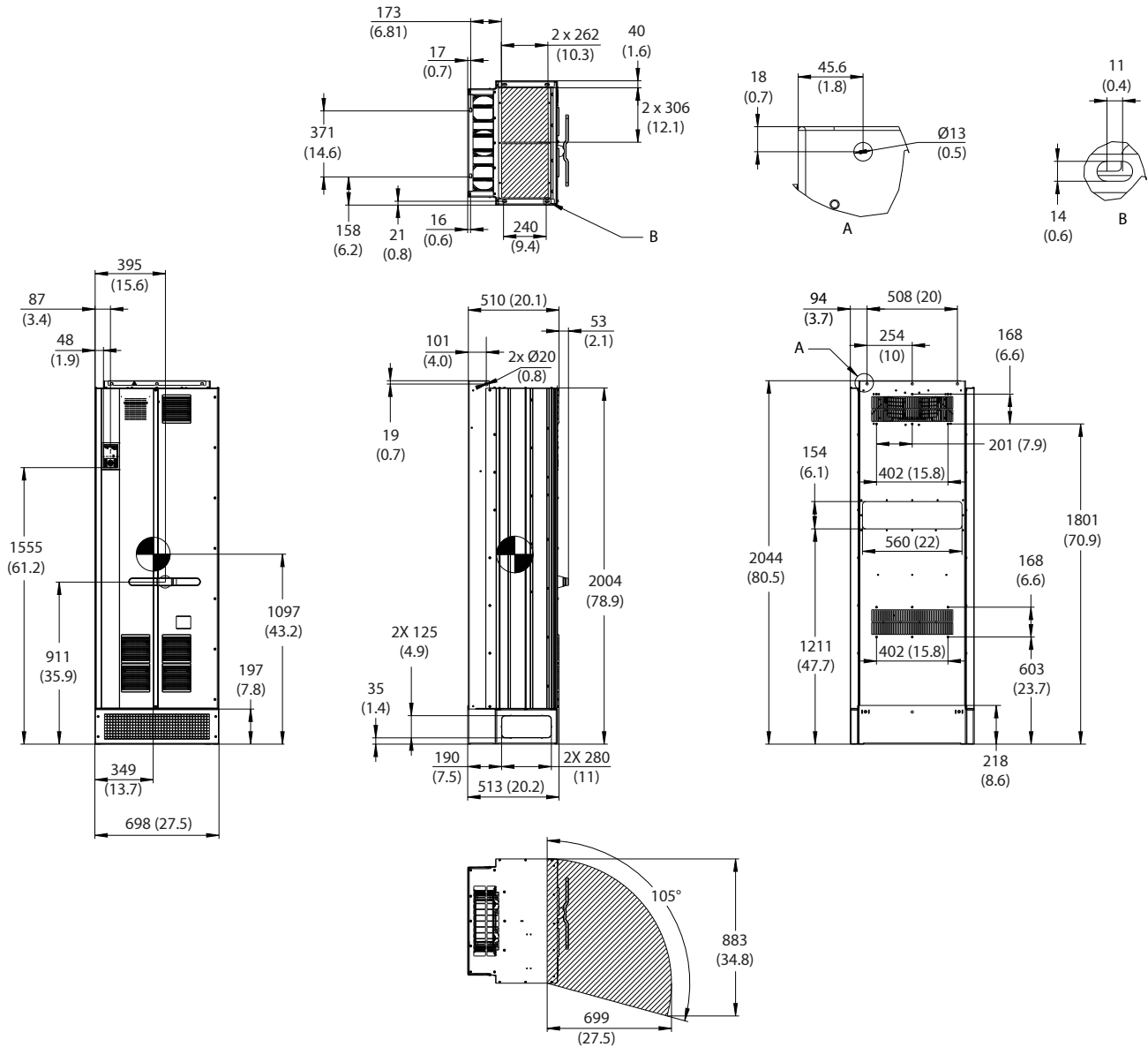

e30bj222.12

Figure 53: FB12 Dimensions

10 Mechanical Installation Considerations

10.1 Contents of the Shipment

The shipment contains:

- The drive including functional extension options (if ordered).
- Accessories needed for installing the drive (for example, connectors, EMC plates, cable clamps).
- The safety guide, which provides important safety information related to installing the drive.
- The installation guide, which provides instructions related to the mechanical and electrical installation of the drive.

10.2 Product Labels

10.2.1 Overview

The drive, control panel, and functional extension options have labels that contain information required for legal or regulatory reasons, a unique identification of each component, and other relevant information.

10.2.2 Product Labels on Drives

The product label on the drive contains information to identify the product, and legal and regulatory information. Depending on the frame, the label is either on the top of the drive or on the front cover of the drive as shown in [Figure 54](#). Frames Fx09–Fx12 have a 2nd label inside the drive. Refer to the drawings available at <https://www.danfoss.com/en/service-and-support/documentation/> for the exact location of the label inside the drive.

When reinstalling the cover for frames FA09–FA12, make sure that the product label on the front cover matches the label inside the drive.

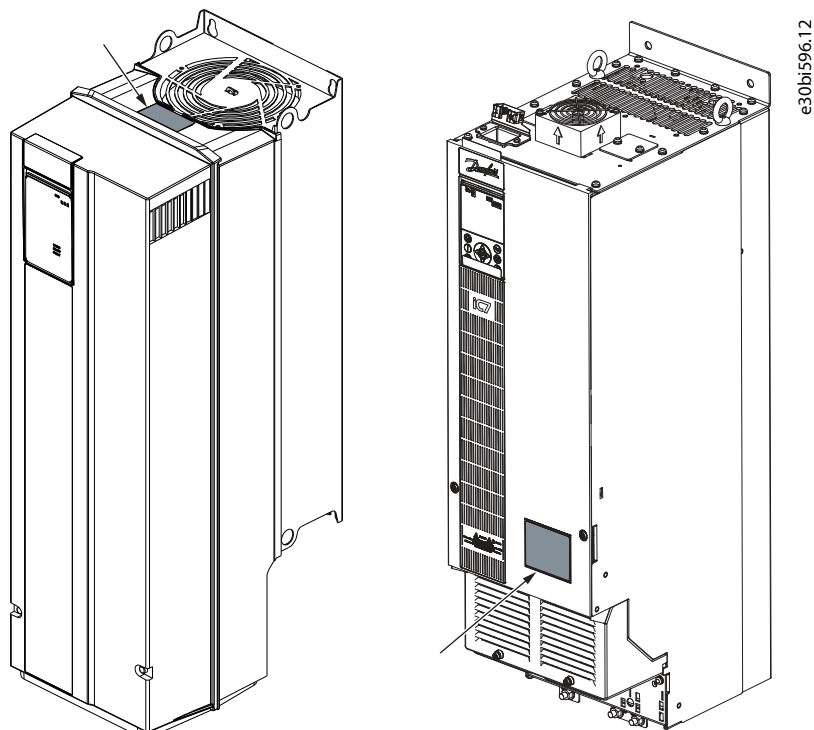

Figure 54: Locations of the Product Labels

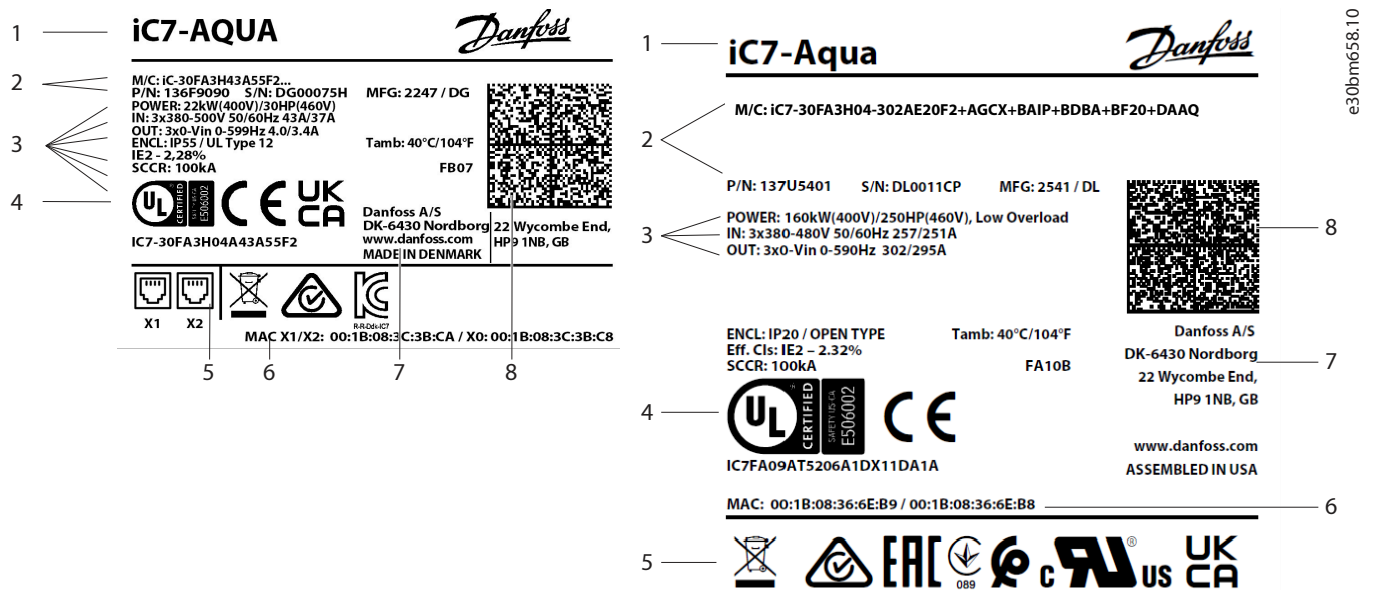

Figure 55: Product Labels for Fx02–Fx08 (Left) and Fx09–Fx12 (Right)

- 1 Product name
- 2 M/C, P/N, S/N, MFG
 - M/C includes the first 22 characters of the model code for frames Fx02–Fx08. For Fx09–Fx12, the complete model code is shown on the label. The complete model code can be read out from the *Device Info* of the drive in MyDrive® Insight or from the 2D code.
 - P/N is the code number of the actual product.
 - S/N is the serial number.
 - MFG specifies the manufacturing year and week followed by assembly site ID.
- 3 Product data
 - The rating is given on 3 lines:
 - ◆ The 1st line lists the typical motor power rating at the referenced voltages.
 - ◆ The 2nd line lists input ratings (voltage range, frequency, and input current at given input voltages).
 - ◆ The 3rd line lists output ratings (voltage range, frequency, and rated output currents at the given input voltages).
 If the drive is rated with different currents in LO and HO mode, both ratings are stated.
 - Enclosure: States the protection rating of the drive both as an Ingress Protection rating and a UL compliant rating.
 - Ambient temperature: States the ambient temperature range without derating needed. For complete data, see [Derating for Operating Conditions](#).
 - Efficiency class: Efficiency class according to the ErP directive. The value given for 90% frequency/100% current working point. For more details, see MyDrive® Select.
 - Frame designation and control board: Indicates the frame designation and the control board variant of the drive, making reference to documentation easy.
 - SCCR: The SCCR describes the maximum allowed short-circuit rating. For more information on short-circuit ratings with a specific fuse, see [Fuses and Circuit Breakers](#).
- 4 UL and CE compliance
Compliance codes are stated together with detailed information on approval limitations (if any).
- 5 Other warnings and compliance information
- 6 MAC address
MAC address of Ethernet communication ports of the drive.

- 7 Company name and address
- 8 2D code – accessible by using a Datamatrix ECC 200 compatible barcode reader – containing the model code, code number, serial number, and manufacture year and week.

The control panel and functional extensions have dedicated labels. For details, see [10.2.4 Product Labels on Functional Extensions](#) and [10.2.5 Product Labels on Control Panels](#).

10.2.3 Package Labels

The package label is placed on the drive packaging and contains information about the drive.

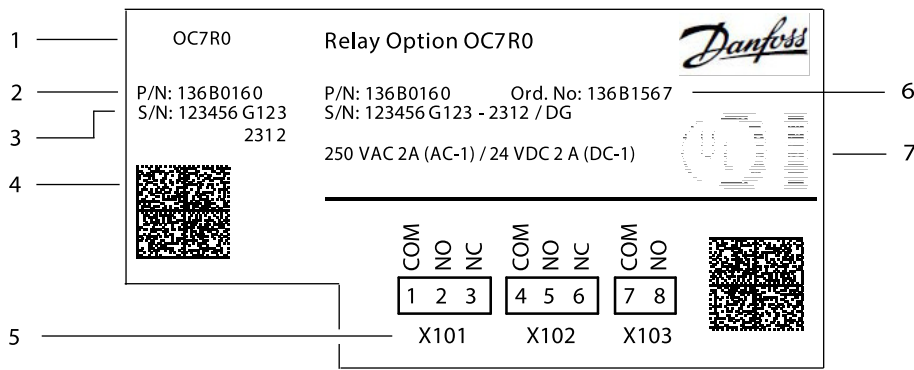

Figure 56: Example of a Package Label

- | | | | |
|---|--|---|---|
| 1 | Product name and other product-specific data | 2 | Code number, serial number, and manufacturing year and week (YYWW) |
| 3 | Approval marking required on packaging
More approval markings are shown on the drive. | 4 | Barcode with EAN information |
| 5 | Company name and address | 6 | 2D code – accessible by using a Datamatrix ECC 200 compatible barcode reader – containing the model code, code number, serial number, and manufacture year and week |

10.2.4 Product Labels on Functional Extensions

Each functional extension has a product label that includes essential information about the option.



e30bk450.11

Figure 57: Example of a Product Label on a Functional Extension

1	Product name of the functional extension	2	Code number identifying the option
3	Serial number	4	2D code containing code number, serial number, production year and week, and product name
5	Identification of I/O connections on the option	6	Code number identifying the option kit that was ordered
7	Compliance and approval markings (if not covered by drive approvals)		

For further details, refer to option documentation.

10.2.5 Product Labels on Control Panels

The product label is on the back of the control panel.



e30bk912.

Figure 58: Example of a Control Panel Label

The label contains the following information:

- Product name, code number, and serial number.
- Company name and address.
- 2D code – accessible by using a Datamatrix ECC 200 compatible barcode reader – containing the code number, serial number, and manufacturing year and week.
- Compliance and approval markings.
- Radio communication and MAC address information.



NOTE: The radio communication and MAC address information only apply to control panel options with wireless communication capabilities.

10.3 Disposal

10.3.1 Recommended Disposal

When the product reaches the end of its service life, its primary components can be recycled.

Before the materials can be removed, the product must be disassembled. Product parts and materials can be dismantled and separated. Generally, all metals, such as steel, aluminum, copper and its alloys, and precious metals can be recycled as material. Plastics, rubber, and cardboard can be used in energy recovery. Printed circuit boards and large electrolytic capacitors with a diameter of over 2.5 cm (1 in) need further treatment according to IEC 62635 guidelines. To ease recycling, plastic parts are marked with an appropriate identification code.

Contact the local Danfoss office for further information on environmental aspects and recycling instructions for professional recyclers. End-of-life treatment must follow international and local regulations.

All products are designed and manufactured in accordance with Danfoss company guidelines on prohibited and restricted substances. A list of these substances is available at www.danfoss.com.



This symbol on the product indicates that it must not be disposed of as household waste. Do not dispose of equipment containing electrical components together with domestic waste.

It must be handed over to the applicable take-back scheme for the recycling of electrical and electronic equipment.

- Dispose of the product through channels provided for this purpose.
- Comply with all local and currently applicable laws and regulations.

10.3.2 Real-time Clock Battery Disposal

Dispose of the old battery according to local disposal rules or applicable laws.



RISK OF FIRE OR EXPLOSION

- Do not recharge or disassemble the battery, or dispose of it in fire.

10.4 Storage until Installation

10.4.1 Reforming the Capacitors

For drives that are in storage and do not have voltage applied, maintenance of the capacitors in the drive may be required.

Reforming is required if the drive has been stored without applying voltage for more than 3 years. Reforming is possible only with drives with DC terminals. See [Table 58](#) for DC-link capacitor maintenance and reforming.

When reforming the capacitors:

- The reforming voltage must be 1.35–1.45 times the rated mains voltage. If the DC-link voltage stays at a low level and does not reach approximately $1.41 \times U_{\text{mains}}$, contact the local service agent.
- The supply current draw must not exceed 500 mA.

When the drive is operational, DC-link capacitors that have not been reformed can be damaged.

Table 58: Drive Storage Duration and Reforming Recommendations

Storage duration	Reforming guideline
Under 2 years	No reforming required. Connect to mains voltage.
2–3 years	Connect to mains voltage and wait a minimum of 30 minutes before loading the drive.
Over 3 years	Using a DC supply connected directly to the DC-link terminals of the drive, ramp up the voltage 0–100% of DC-bus voltage in increments of 25%, 50%, 75%, and 100% rated voltage under no load for 30 minutes at each increment. See Figure 59 .

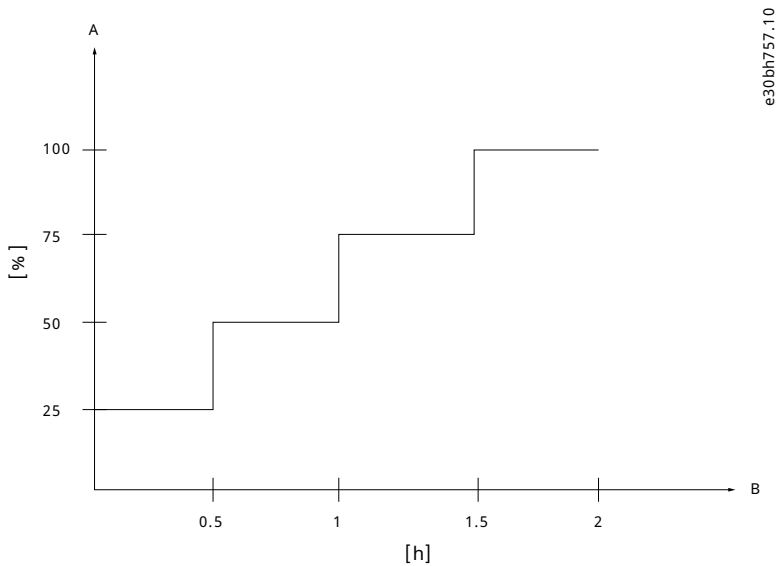

Figure 59: Reforming Procedure for DC Capacitors

A	Reforming voltage (percentage of rated voltage)	B	Hours
---	---	---	-------

Table 59: DC Bus Voltage Ramp-up Value

AC input voltage	Voltage across the DC link
380–480 V AC	680 V DC

10.4.2 Safe Transportation and Storage

Follow all information on transportation, storage, and proper handling given in the product-specific documentation. That includes:

- If the drive is stored before installing it, make sure that the ambient conditions agree to the specifications given in [8.3.8.3 Ambient Conditions during Storage](#).
- If the package is kept in storage for more than 4 months, keep it in controlled conditions:
 - Make sure that the temperature variation is small.
 - Make sure that the humidity is less than 50%.
- Only use lifting and handling equipment rated and suitable for the purpose.
- Check the weight of the drive and lift the drive with a lifting device, if needed. In this case, use the lifting eyes/bars designed for this purpose.
- Check the center of gravity on the packaging or on the drive before lifting the drive and avoid tilting to prevent the drive from overturning.
- Keep the drive in its package until installation. After unpacking, protect the drive from dust, debris, and moisture.

10.5 Prerequisites for Installation

10.5.1 Overview

To secure the best conditions and operation of the drive in its application, it is recommended to check the following points before selecting a drive:

- Check the operating environment against ambient conditions. See [8.3.8.4 Ambient Conditions during Operation](#).
- Consider the placement of the drive and handling during installation, including the need for lifting devices. See [8.8 Packaging](#) for the weights and mechanical dimensions of the packaging, and chapter *Exterior and Terminal Dimensions* for the dimensions of the drives.
- Consider the needs for access to the drive during operation. See [10.8.2 Mounting Considerations](#).
- Consider the needs for maintenance access. See [10.8.9 Recommended Space for Service Access](#).

10.5.2 Operating Environment

Make sure that the drive is installed within the specified installation conditions to ensure proper operation and expected lifetime of the product.

Table 60: Operating Environment Specifications

Environment	Specifications
Temperature	The drive must be installed in a location where the operational temperature range is compliant to the specifications of the drive. Consider both temperature at operation and temperature at storage (unpowered drive). If the nominal temperature rating is exceeded, derating must be applied. For more information about derating, see Derating for Operating Conditions and 10.6.2 Derating for Ambient Temperature .
Altitude	Ensure that the drive is installed at the allowed altitude for proper cooling and compliance with isolation spacing. At altitudes above 1000 m (3300 ft), derating of drive performance applies. Derating is to be applied to the maximum output current or maximum operational temperature. Ensure that the drive is rated for the actual application. Maximum altitude depends on power grid configuration and grid voltage. Limitations are stated in 8.3.8.4 Ambient Conditions during Operation . For more information, see Ambient Conditions and 10.6.3 Derating for Altitude .
Vibration and shock	Ensure that the drive is installed in a location where it is not exposed to vibration and shock levels exceeding its specifications. If exposed to higher levels of vibration and shock, using dampers for installation is recommended. Special requirements are fulfilled when the drive is ordered with marine approval. For more information, see Ambient Conditions .
Humidity	The drive must be installed in a location where the humidity level is compliant to the specifications of the drive. If the installation area does not fulfill the required conditions, alternative measures can be taken by selecting other protective cabinets for installation, built-in heating elements, or a dehumidifier. For more information, see Ambient Conditions .

Table 60: Operating Environment Specifications - (continued)

Environment	Specifications
Dust, fiber, and airborne particles	<p>Depending on the protection rating class, the allowed exposure to dust, fibers, and other airborne particles varies:</p> <ul style="list-style-type: none"> IP20, IP21, UL Open Type, and UL Type 1 enclosures are not protected against dust, fibers, and other airborne particles, and should be installed in locations where these are not present, or in a dedicated enclosure. IP54/55 and UL Type 12 are protected against dust, fibers, and other airborne particles. Make sure that airborne particles are not clogging the heat sink and fan, because clogging limits the cooling of the drive. The drive detects clogging and reduces performance, or stops operation. Do not install the drive in a location where it is exposed to conductive particles. <p>For more information, see Ambient Conditions.</p> <p>For more information on heat sink and fan maintenance, see 10.7.4 Heat Sink and Fan Maintenance and Service.</p>
Gases	<p>When installing the drive, exposure to gases must be observed. The drive is not intended to be installed in a location where it is exposed to explosive gases. If exposed to corrosive gases, relevant precautions must be taken. These precautions include selecting a drive with a higher protection rating, adding protective coating as an optional selection to the drive, or by installing the drive in a protective cabinet.</p> <p>For more information, see Ambient Conditions.</p>

10.6 Derating for Operating Conditions

10.6.1 Overview

If the drive is used outside the nominal specifications, consider derating.

Apply derating when:

- Operating at temperatures above the nominal operating temperature ranges, which are:
 - 6-pulse (3N) drives: up to 40 °C (104 °F) in low overload and 50 °C (122 °F) in high overload. For frames Fx09–Fx12, the maximum temperature is up to 45 °C (113 °F).
 - Ultra low-harmonic (3H) drives: up to 40 °C (104 °F) in low overload and 45 °C (113 °F) in high overload.
- Operating at altitudes above 1000 m (3300 ft).
- Operating at a low output frequency (< 5 Hz).
- Operating with increased switching frequency.

Derating typically means operation at a reduced output current and limited maximum temperature.

[MyDrive® Select](#) supports making a more precise selection when selecting a frequency converter for operating conditions other than the nominal specifications. MyDrive® Select includes detailed data on the iC7 drives.

10.6.2 Derating for Ambient Temperature

If the frequency converter is operated above the maximum nominal temperature, derating is required.

The maximum nominal temperature depends on the drive and is:

- Up to 40 °C (104 °F) in the low-overload mode and 50 °C (122 °F) in the high-overload mode for 6-pulse (3N) drives. For frames Fx09–Fx12, the maximum temperature is up to 45 °C (113 °F) in the high-overload mode.
- Up to 40 °C (104 °F) in the low-overload mode and 45 °C (113 °F) in the high-overload mode for ultra low-harmonic (3H) drives.

For more information on derating for higher temperatures and altitude, including the derating curves, see [10.6.3 Derating for Altitude](#). The maximum allowed temperature is 60 °C (140 °F).

In emergency situations, it is possible to override protections, and operate the drive at temperatures up to 70 °C (158 °F). Operation at this temperature is controlled with a dedicated setting in the software, and affects warranty.

10.6.3 Derating for Altitude

Cooling efficiency is reduced at higher altitudes. As a result, derating is required above 1000 m (3300 ft).

The maximum allowed altitude is 4400 m (14400 ft) at a system voltage (phase-ground voltage of grid) up to 300 V according to IEC 61800-5-1 on electrical safety. At system voltages above 300 V, the altitude is restricted to 2000 m (6500 ft). All 200–240 V grid types and 3-phase star-connected grids (TN, TT, IT) up to 500 V exhibit a system voltage of less than 300 V. All 3-phase delta grids above 380 V exhibit a system voltage above 300 V.

When selecting a frequency converter, follow the guidelines for derating based on ambient temperature and altitude. If needed, select an oversized drive.

Derating at low overload

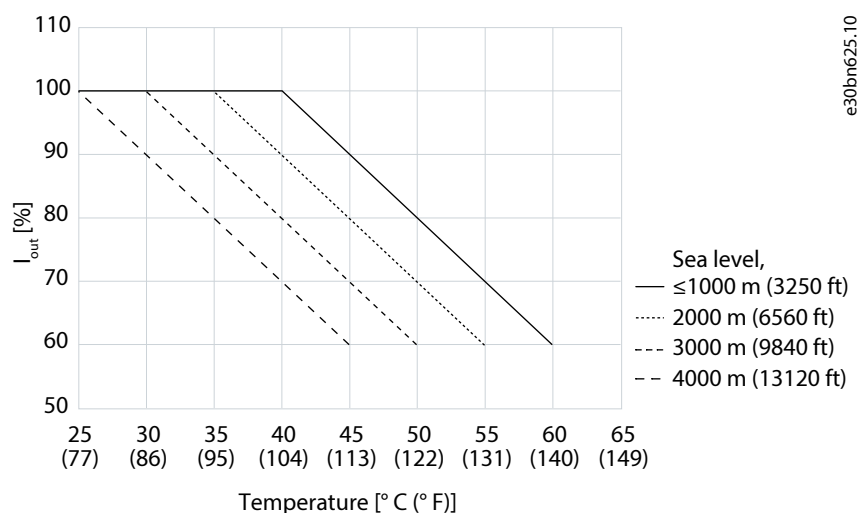

Figure 60: Derating of Output Current Versus Altitude and Ambient Temperature for 6-pulse (3N) Drives, Frames Fx06-Fx08 with Low Overload (LO)

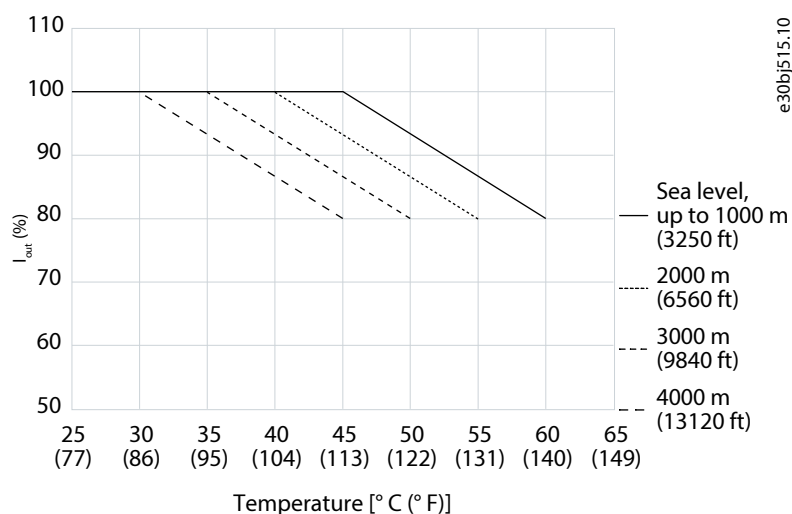

Figure 61: Derating of Output Current Versus Altitude and Ambient Temperature for 6-pulse (3N) Drives, Frames Fx09-Fx12 with Low Overload (LO)

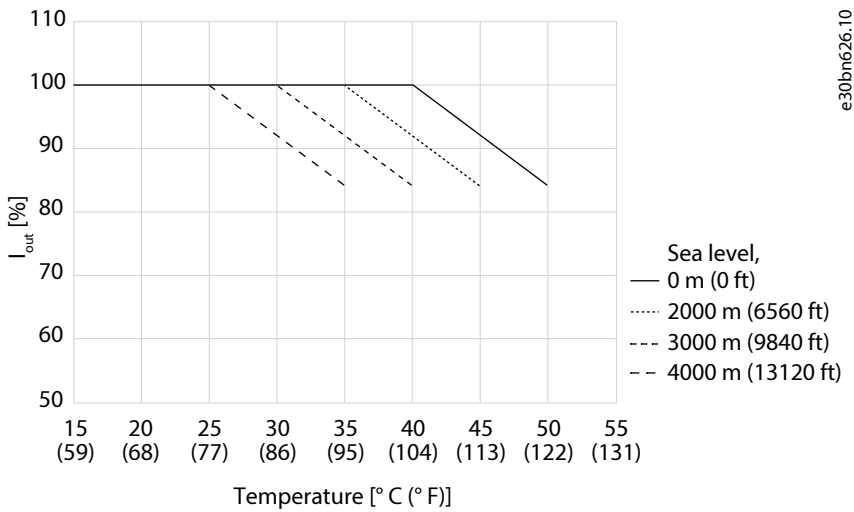

Figure 62: Derating of Output Current Versus Altitude and Ambient Temperature for Ultra Low-harmonic (3H) Drives, Frames Fx07 and Fx10b with Low Overload (LO)

Derating at high overload

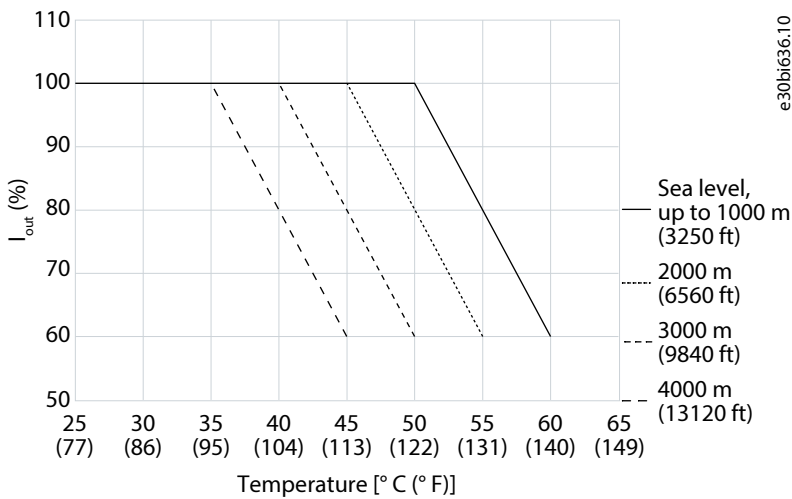

Figure 63: Derating of Output Current Versus Altitude and Ambient Temperature for 6-pulse (3N) Drives, Frames Fx06-Fx08 with High Overload (HO)

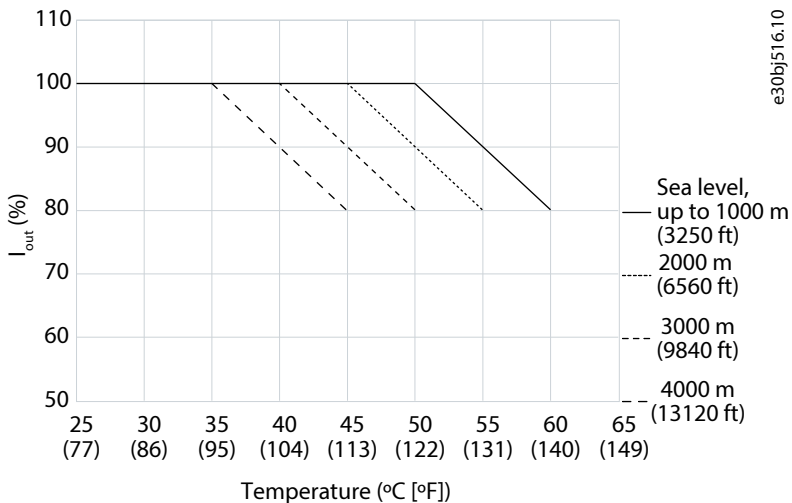

Figure 64: Derating of Output Current Versus Altitude and Ambient Temperature for 6-pulse (3N) Drives, Frames Fx09-Fx12 with High Overload (HO)

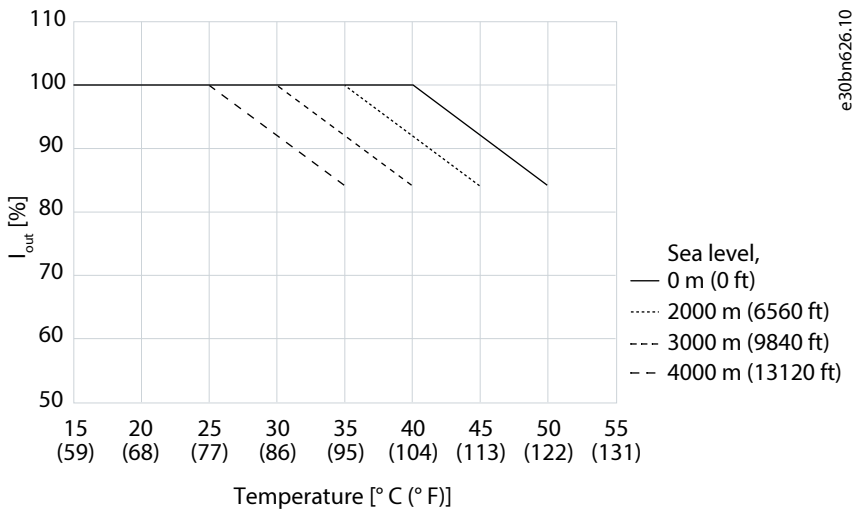

Figure 65: Derating of Output Current Versus Altitude and Ambient Temperature for Ultra Low-harmonic (3H) Drives, Frames Fx07 and Fx10b with High Overload (HO)

10.6.4 Derating for Output Frequency

At low-speed operation (output frequencies below 5 Hz) and high output current, the frequency converter is thermally loaded in an unusual way. To avoid limiting the lifetime of the frequency converter, derating of the output current is required.

Depending on duration and the temperature of the heat sink, the drive may automatically derate the transient current capacity when ramping up or down the motor (below 5 Hz).

For more specific guidance, use MyDrive® Select.

10.6.5 Derating for Switching Frequency

Derating of the output current is required when the drive is operated above the nominal switching frequency.

See the following graphs for recommended derating for each frame designation.

Derating at low overload

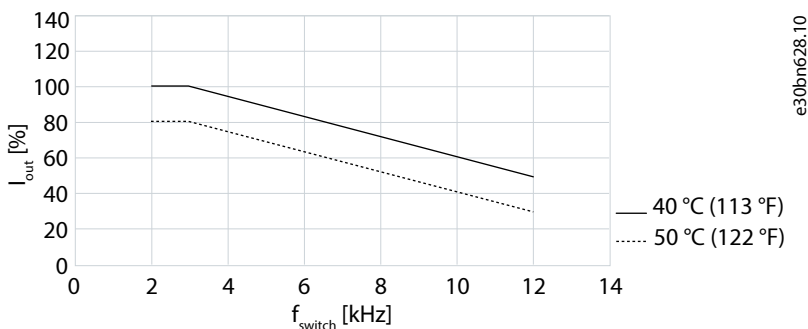

Figure 66: Derating of Output Current Versus Switching Frequency for 6-pulse (3N) Drives Fx06-Fx08 with Low Overload (LO)

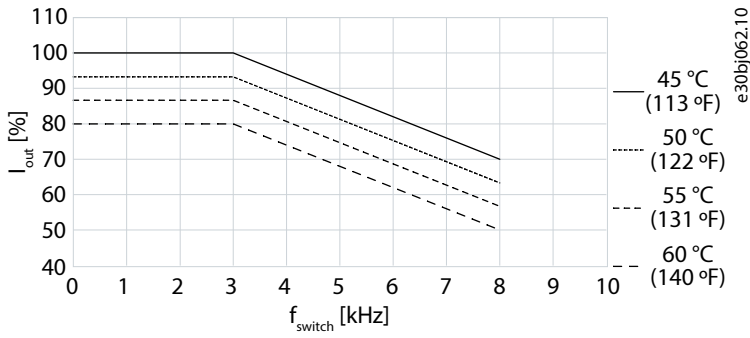

Figure 67: Derating of Output Current Versus Switching Frequency for 6-pulse (3N) Drives, Frames Fx09–Fx10 with Low Overload (LO)

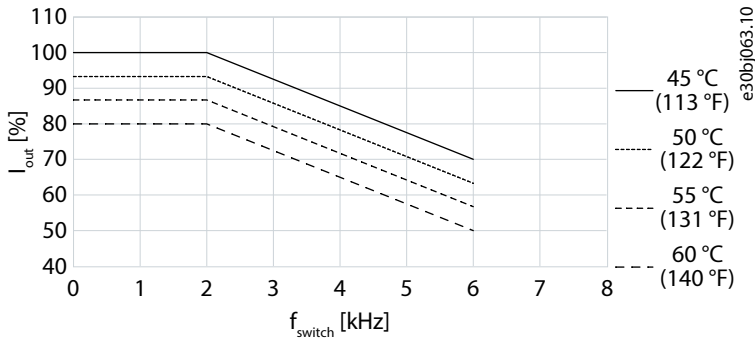

Figure 68: Derating of Output Current Versus Switching Frequency for 6-pulse (3N) Drives, Frames Fx11–Fx12 with Low Overload (LO)

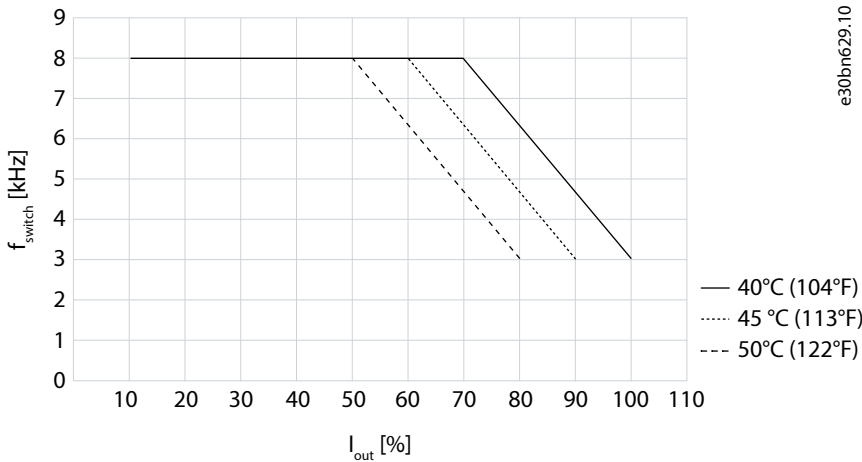

Figure 69: Derating of Output Current Versus Switching Frequency for Ultra Low-Harmonic (3H) Drives Frame Fx07 and Fx10b with Low Overload (LO)

Derating at high overload

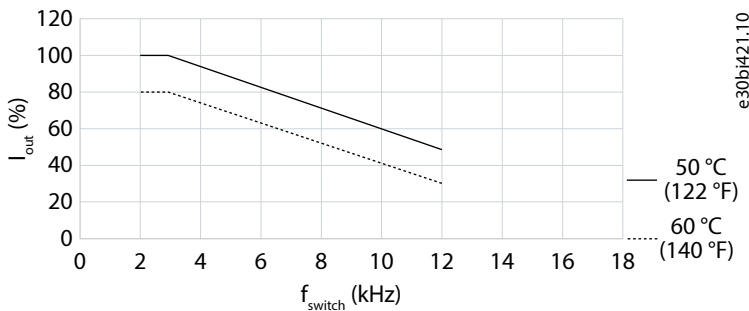

Figure 70: Derating of Output Current Versus Switching Frequency for 6-pulse (3N) Drives, Frames Fx06–Fx08 with High Overload (HO1)

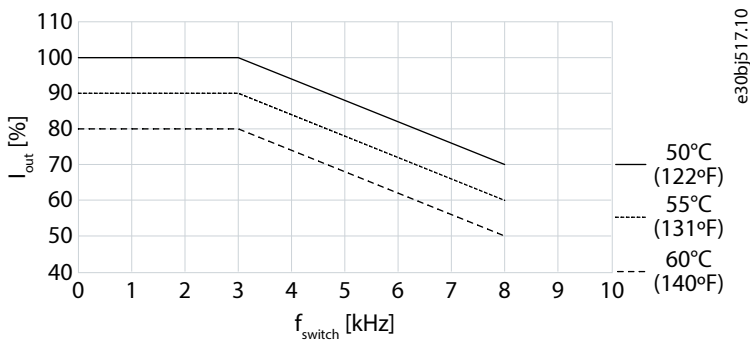

Figure 71: Derating of Output Current Versus Switching Frequency for 6-pulse (3N) Drives, Frames Fx09–Fx10 with High Overload (HO1)

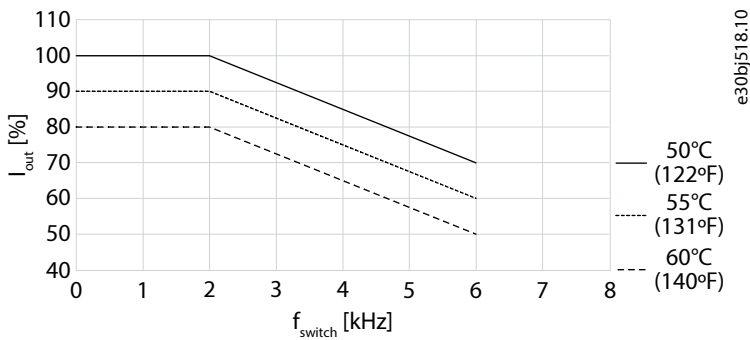

Figure 72: Derating of Output Current Versus Switching Frequency for 6-pulse (3N) Drives, Frames Fx11–Fx12 with High Overload (HO1)

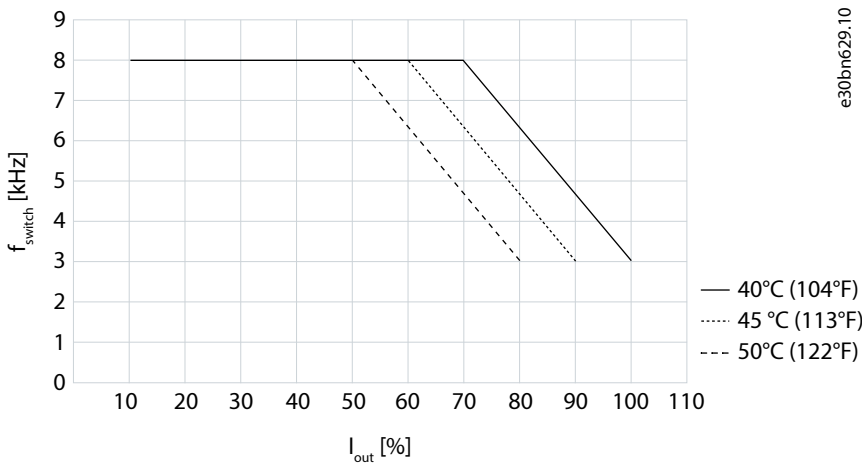

Figure 73: Derating of Output Current Versus Switching Frequency for Ultra Low-Harmonic (3H) Drives, Frames Fx07 and Fx10b with High Overload (HO1)

10.7 Inspection and Maintenance Considerations

10.7.1 Overview

Regular inspections are recommended for all technical equipment, including Danfoss variable frequency drives, to initiate preventive maintenance actions to ensure trouble-free operation and long life of the drive. It is also recommended as a good service practice to record a maintenance log with counter values, date, and time describing the maintenance and service actions.

Danfoss offers the DrivePro® Preventive Maintenance Service to help extend the lifetime of the drive and increase the performance of the application with scheduled maintenance including customized part replacements.

DrivePro® services are tailored to the specific application and operating conditions.

CAUTION

HOT SURFACES

The drive contains metal components that are still hot even after the drive has been powered off. Failure to observe the high-temperature symbol (yellow triangle) on the drive can result in serious burns.

- Be aware that internal components, such as busbars, may be extremely hot even after the drive has been powered off.
- Do not touch exterior areas that are marked by the high-temperature symbol (yellow triangle). These areas are hot while the drive is in use and immediately after being powered off.

10.7.2 Regular Maintenance

In general, Danfoss recommends the following inspections and maintenance actions for iC7 air-cooled frequency converters:

- Visual inspection, for example, for signs of overheating, aging, corrosion, dusty and damaged components, and for blockages or constrictions in the air passages of the cooling channel as well as conditions of sealings.
- Cleaning of filters and heat sink (cooling channel) if needed.
- Checking wiring conditions, including the tightness of power connections, grounding, and control cables.
- Reading data or parameterizing by connecting a PC to the drive or using the memory card to, for example, copy drive settings.
- If applicable, checking the stocking conditions of spare parts and exchange units. Consider reforming the capacitors if exceeding the recommended maximum storage period. For details, see [10.4.1 Reforming the Capacitors](#).
- Checking the condition and operational status of all cooling fans. With the power off, the fan axis should feel tight, and when spinning the fan with a finger, the rotation should be almost silent and not have abnormal rotation resistance. When in RUN mode, fan vibration, excessive or strange noise is a sign of the bearings wearing, and the fan must be replaced.

NOTICE

The service schedule for part replacements can vary depending on operating conditions. Under specific conditions, the combination of stressful operation and environmental conditions work together to reduce the lifetime of the components significantly. These conditions can include, for example, extreme temperature, dust, high humidity, hours of use, corrosive environment, and loading. If the drive is operated in environments near the limit or beyond design boundaries, it is highly recommended to pay special attention on regular inspections and initiate necessary maintenance actions.

- Replace worn or damaged parts with original spare parts. For service and support, contact the local supplier.

10.7.3 Service Access

When planning the installation, proper access for service and maintenance needs must be considered. In general, it is recommended to ensure:

- Access to power cabling and connectors.
- Access to control wiring.
- Access to clean the cooling system (cooling channel and fan filters).
- Access to the port to connect the drive to a PC.

10.7.4 Heat Sink and Fan Maintenance and Service

The heat sink fins pick up dust from the cooling air. If the heat sink is not clean, the drive runs into overtemperature warnings and faults. When necessary, clean the heat sink.

The lifespan of the cooling fan of the drive depends on the running time of the fan, ambient temperature, and dust concentration. Fans can be removed from the drive for cleaning. Replacement fans are available from Danfoss.

10.7.5 Backup Battery Exchange

If the battery of the interface board needs to be replaced, use the type and brand of battery defined in [8.3.7 Real-time Clock](#).

Using a different battery may cause a risk of fire or explosion. Only qualified personnel are allowed to exchange the battery.

CAUTION

RISK OF FIRE AND EXPLOSION

- Replace the battery with a Panasonic BR1632A or CR2032 coin-cell battery only, depending on the control board type. Using another battery may present a risk of fire or explosion. Only qualified personnel can exchange the battery.
- For detailed safety information, refer to the documentation provided with the battery.

CAUTION

RISK OF FIRE OR EXPLOSION

- Do not recharge or disassemble the battery, or dispose of it in fire.

10.8 Mechanical Installation

10.8.1 Overview

The drive is mounted primarily on a wall or in an enclosed cabinet, or on structures (for example, metal frames or beams). See [Table 61](#) for more information on mounting surfaces for the different frames.

The products have been designed for installation type E/F according to IEC 60204-1/60364-5-52/61439-1 and NPFA 70, with a maximum of 3 sets of power cables in parallel in 1 tray.

If frames FK09a, FK09b, FK10a, and FB10a are installed on the floor, a dedicated pedestal is required.

Table 61: Mounting Surfaces for Drives

Frame	Cabinet	Wall	Structure	Floor
FA02–FA12, FA10b ⁽¹⁾	X	–	–	–
FK03–FK08	–	X	X	–
FK09a, FK09c, FK10a, FK10b	–	X	–	X ⁽²⁾
FK10c, FK11, FK12	–	–	–	X
FB03–FB08	–	X	X	–
FB09a, FB09c, FB10a, FB10b	–	X	–	X ⁽²⁾
FB10c, FB11, FB12	–	–	–	X

1) This BDM/CDM/PDS does not provide comprehensive mitigation for fire hazards. IP20/UL Open Type drives must be installed inside a supplementary enclosure, or in a restricted access area which provides appropriate protection against the spread of fire.

2) Optional floor mounting using pedestal kits. See [12.4 Ordering Options and Accessories](#) for information on ordering the kits.

For more details on installing the drives on different surfaces, see [10.8.3 Mounting Locations](#).

10.8.2 Mounting Considerations

When selecting and planning the installation site, observe the following considerations:

- The mounting surface supports the weight of the drive.
- The mounting surface must be non-flammable.

- The drive is installed vertically, but in special cases it can also be mounted in alternate directions. Installing the drive in alternate directions affects the performance of the drive. For more information, see [10.8.4 Mounting Orientation](#).
- Ensure proper space for lifting the drive, especially when lifting equipment is needed.
- Follow local regulations when lifting the drive. For details, refer to the product-specific installation and safety guides.
- Proper inlet and outlet spacing secures free airflow over the heat sink to enable proper cooling.
- The drives can be mounted side by side to save space in cabinets, or when mounted on walls in control rooms.
- There must be enough space in front of the drive for operating the control panel.
- Ensure proper space for the installation and placement of cables used for connecting the drive.
- To remove covers or open doors for service access, enough space must be left in front of the drive.

WARNING



SHOCK HAZARD

Touching an uncovered motor, mains, or DC connection plug or terminal can result in death or serious injury.

- All plugs and terminal protection covers for the motor, mains, and DC connections must be installed within the IP20 enclosure to provide an IP20 protection rating. If plug and terminal covers are not installed, the protection rating is considered IP00.

10.8.3 Mounting Locations

The drives are designed for installation in weather-protected environments. For more information, see [8.3.8.1 Overview](#). When mounting the drive on the wall, or in a cabinet, the installation must be vertical and the mounting surface must be solid, flat, and non-flammable.

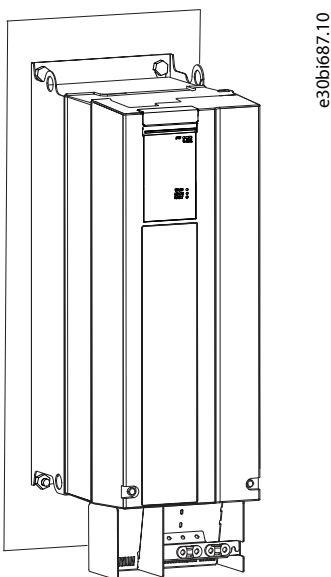

Figure 74: Mounting on the Wall or in a Cabinet

The iC7-Aqua drives can also be mounted on structures (for example, metal frames or beams) as shown in [Figure 75](#). Do not expose the drive to bending forces from the structure. The installation must be vertical (as defined in [10.8.4 Mounting Orientation](#)), and the structure must be non-flammable.

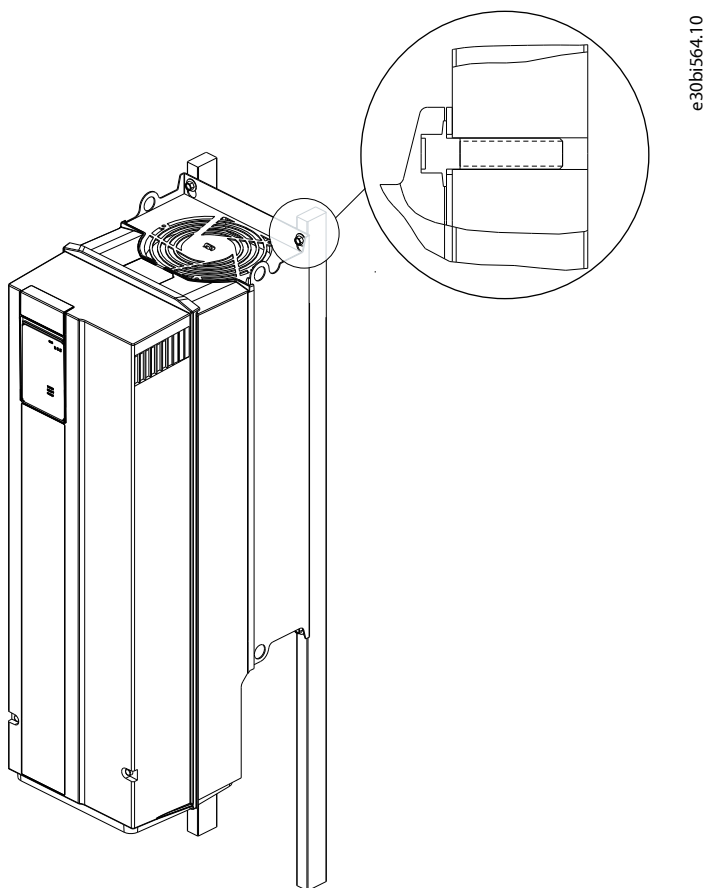

Figure 75: Mounting on Structures

The drives are designed with a closed air-guiding channel, which secures the correct airflow for cooling. It must remain in the drive to ensure proper cooling. If defective, replace the air-guide plate. For information on ordering self-service parts, see [12.5 Ordering Self-service Parts](#).

IP21/UL Type 1 rated frames FK09–FK12 can also be mounted free-standing on floors. Floor-mounting FK09–FK10 frames requires a dedicated pedestal. Frames FK11–FK12 are shipped with a pedestal. For more information, refer to the installation guides for pedestal kits.

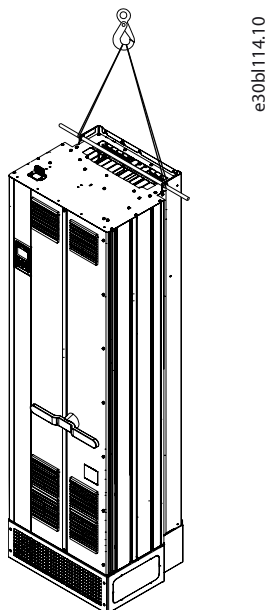

Figure 76: Mounting on a Pedestal

10.8.4 Mounting Orientation

The drive can be mounted in different directions, depending on the frame. Mounting in directions other than vertical affects drive performance. See [Table 62](#) and [Table 63](#) for more information on the effects of mounting direction on drive performance.

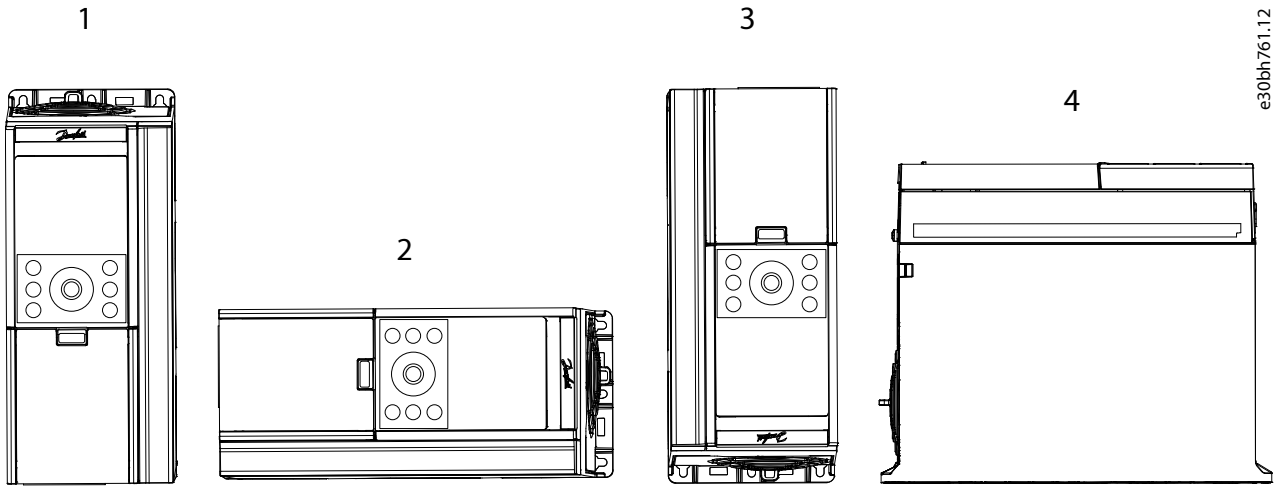

Figure 77: Mounting Orientations for Drives

Table 62: Mounting Orientations and Effects on Performance for IP20/UL Open Type Drives (FA02–FA12)

Orientation	Allowed for frame	Effects on performance
1 – Vertical installation	FA02–FA12	None
2 – Horizontal installation (rotated 90°)	FA02–FA08	<ul style="list-style-type: none"> Limited robustness to vibration and shock Side-by-side mounting not possible
	FA09–FA12	None
3 – Turned upside down	No	–
4 – Mounted on back side	FA02–FA08	<ul style="list-style-type: none"> Protection reduced to IP00 Limited robustness to vibration and shock Side-by-side mounting not possible

Table 63: Mounting Orientations and Effects on Performance for IP21/UL Type 1 and IP54/IP55/UL Type 12 Drives (FK03–FK12/FB03–FB12)

Orientation	Allowed for frames	Effects on performance
1 – Vertical installation	FK03–FK12	None
	FB03–FB12	
2 – Horizontal installation (rotated 90°)	No	–
3 – Turned upside down	No	–
4 – Mounted on back side	FK06–FK08	<ul style="list-style-type: none"> Complies only to IP20/UL Open Type Not protected against dripping water Limited robustness to vibration and shock Side-by-side mounting not possible
	FB06–FB08	

10.8.5 Recommended Fasteners

Check the recommended sizes of screws, bolts, or studs for mounting the drive in the following tables.

Table 64: Recommended Screws, Bolts, and Studs for IP20/UL Open Type Frames

Frame	Drive weight [kg (lb)]	Screw/Bolt/Stud size
FA02	4.7 (10.4)	4 x M5 (3/16") ⁽¹⁾
FA04	11.6 (25.6)	4 x M6 (3/16")
FA05	14.1 (31.1)	4 x M6 (3/16")
FA06	26 (57)	4 x M8 (5/16")
FA07	38 (84)	4 x M8 (5/16")
FA08	55 (121)	4 x M8 (5/16")
FA09	81 (179)	4 x M10 (3/8")
FA10	127 (280)	4 x M10 (3/8")
FA10b	158 kg (348 lb)	6 x M10 (3/8")
FA11	225 (496)	6 x M12 (1/2")
FA12	298 (657)	6 x M12 (1/2")

1) If the installation site is not exposed to vibration or shock, frames FA02–FA03 can be mounted with 3 screws. For more information, see [10.8.6.2 Drilling Patterns for Wall-mounted Frames \(FA02–FA12\)](#).

Table 65: Recommended Screws, Bolts, and Studs for IP21/UL Type 1 Frames

Frame	Drive weight [kg (lb)]	Screw/Bolt/Stud size
FK03	9 (20)	4 x M6 (3/16")
FK05	14 (31)	4 x M6 (3/16")
FK06	28 (62)	4 x M8 (5/16")
FK07	38 (84)	4 x M8 (5/16")
FK08	62 (137)	4 x M8 (5/16")
FK09a	89 (196)	4 x M10 (3/8")
FK09c	107 (236)	4 x M10 (3/8")
FK10a	139 (306)	4 x M10 (3/8")
FK10b	162 (357)	6 x M10 (3/8")
FK10c	178 (392)	2 x M10 (3/8") and 8 x M12 (1/2")
FK11	244 (538)	9 x M12 (1/2")
FK12	327 (721)	9 x M12 (1/2")

Table 66: Recommended Screws, Bolts, and Studs for IP54/IP55/UL Type 12 Frames

Frame	Drive weight [kg (lb)]	Screw/Bolt/Stud size
FB03	9 (20)	4 x M6 (3/16")
FB05	14 (31)	4 x M6 (3/16")
FB06	29 (64)	4 x M8 (5/16")
FB07	35 (77)	4 x M8 (5/16")

Table 66: Recommended Screws, Bolts, and Studs for IP54/IP55/UL Type 12 Frames - (continued)

Frame	Drive weight [kg (lb)]	Screw/Bolt/Stud size
FB08	60 (132)	4 x M8 (5/16")
FB09a	89 (196)	4 x M10 (3/8")
FB09c	107 (236)	4 x M10 (3/8")
FB10a	139 (306)	4 x M10 (3/8")
FB10b	162 (357)	6 x M10 (3/8")
FB10c	178 (392)	2 x M10 (3/8") and 8 x M12 (1/2")
FB11	244 (538)	9 x M12 (1/2")
FB12	327 (721)	9 x M12 (1/2")

10.8.6 Drilling Patterns

10.8.6.1 Overview

When preparing mounting holes for the installation, use the drilling patterns. The drilling pattern equals the mounting plate of the drive or the cable entry plate, depending on the frame. A drilling template is included in the shipment for the FB03, FB05, FK03, FK05, and Fx10b frames.

The required space for cooling, EMC plates, and other extensions is not included in the drilling patterns.

For total space needed, see the drawings in [External and Terminal Dimensions](#).

10.8.6.2 Drilling Patterns for Wall-mounted Frames (FA02–FA12)

NOTICE

- IP20/UL Open Type frames FA02–FA03 are normally mounted with 4 screws. If not exposed to vibration or shock, they can be mounted with 3 screws only.
- If mounted with 3 screws, use the upper middle screw position. Use the outer positions for the upper screws when mounted with 4 screws.

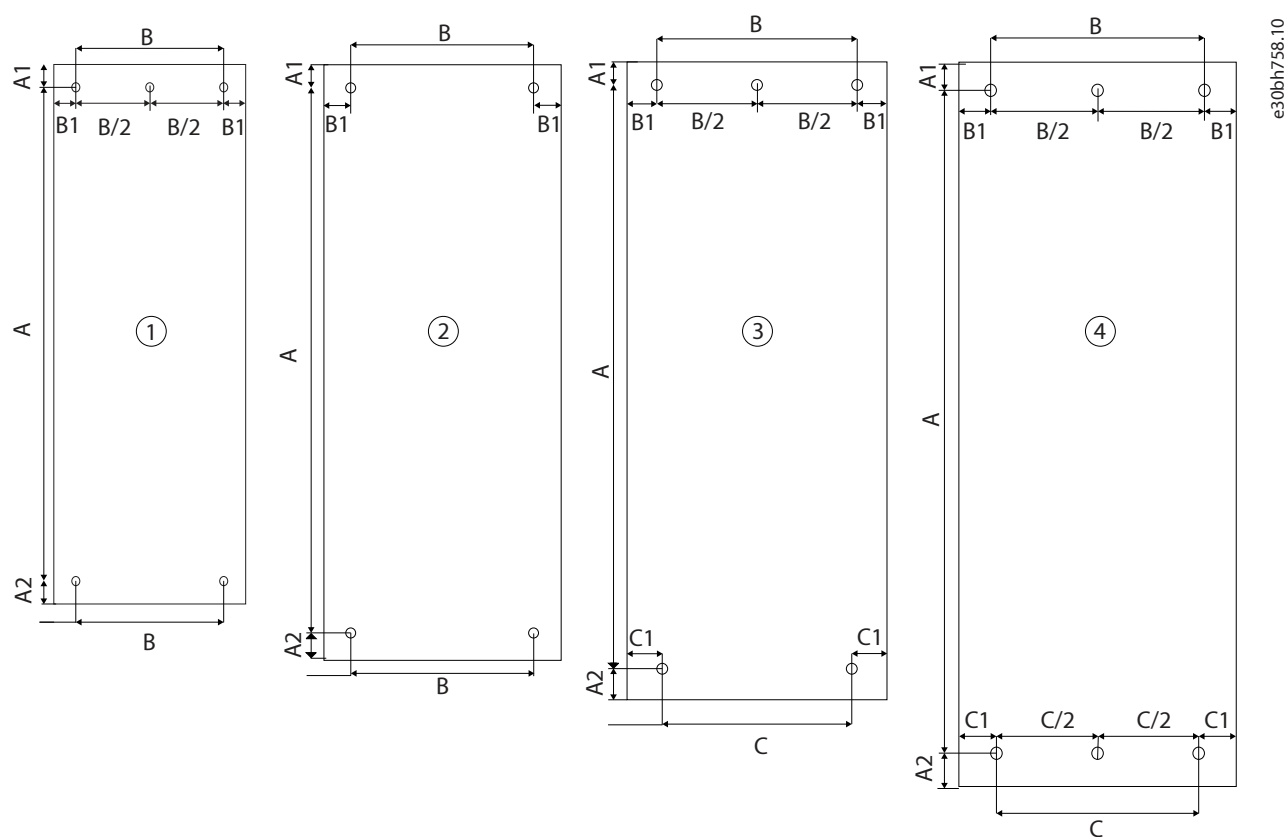

Figure 78: Drilling Patterns for Frames FA02–FA12

Table 67: Drilling Pattern Dimensions for Wall-mounted Frames (FA02–FA12)

Frame	Drilling pattern	A [mm (in)]	A1 [mm (in)]	A2 [mm (in)]	B [mm (in)]	B1 [mm (in)]	C [mm (in)]	C1 [mm (in)]
FA02	1	257 (10.1)	6.5 (0.26)	6.5 (0.26)	70 (2.8)	10 (0.4)	–	–
FA03	1	257 (10.1)	6.5 (0.26)	6.5 (0.26)	94 (3.7)	10 (0.4)	–	–
FA04	2	380 (15)	8 (0.32)	11 (0.43)	105 (4.1)	12.5 (0.5)	–	–
FA05	2	380 (15)	8 (0.32)	11 (0.43)	140 (5.5)	12.5 (0.5)	–	–
FA06	2	535 (21.1)	12 (0.47)	8 (0.32)	170 (6.7)	15 (0.6)	–	–
FA07	2	580 (22.1)	12 (0.47)	8 (0.32)	200 (7.9)	15 (0.6)	–	–
FA08	2	721 (28.4)	12 (0.47)	10 (0.39)	200 (7.9)	27.5 (1.08)	–	–
FA09	3	844 (33.2)	25 (0.98)	20 (0.79)	180 (7.1)	33.1 (1.3)	200 (7.9)	25 (0.98)
FA10	3	1051 (41.4)	25 (0.98)	20 (0.79)	280 (11.0)	33 (1.3)	271 (10.7)	39.5 (1.56)
FA10b ⁽¹⁾	4	1150 (45.2)	15 (0.6)	15 (0.6)	277 (10.9)	35 (1.4)	277 (10.9)	35 (1.4)
FA11	4	1545 (60.8)	17.6 (0.69)	15 (0.59)	412 (16.2)	45.6 (1.8)	430 (16.9)	38.5 (1.52)
FA12	4	1545 (60.8)	17.6 (0.69)	15 (0.59)	508 (20.0)	45.6 (1.8)	526 (20.7)	38.5 (1.52)

1) Drilling template included in the shipment.

10.8.6.3 Drilling Patterns for Wall-mounted Frames (FB03–FB12)

Table 68: Drilling Pattern Dimensions for Wall-mounted Frames (FB03–FB12)

Frame	Drilling pattern	A [mm (in)]	A1 [mm (in)]	A2 [mm (in)]	B [mm (in)]	B1 [mm (in)]	C [mm (in)]	C1 [mm (in)]
FB03 ⁽¹⁾	2	460 (18.11)	8 (0.32)	7.5 (0.3)	150 (5.91)	12.4 (0.49)	–	–
FB05 ⁽¹⁾	2	557 (21.93)	8 (0.32)	10 (0.39)	187 (7.36)	10.5 (0.41)	–	–
FB06	2	535 (21.1)	12 (0.47)	8 (0.32)	170 (6.69)	19.5 (0.77)	–	–
FB07	2	580 (22.8)	12 (0.47)	8 (0.32)	200 (7.9)	19.5 (0.77)	–	–
FB08	2	721 (28.4)	12 (0.47)	10 (0.39)	200 (7.9)	33.5 (1.3)	–	–
FB09a	3	944 (37.2)	25 (0.98)	20 (0.79)	180 (7.1)	33.1 (1.3)	200 (7.9)	63.5 (2.5)
FB09c	3	1380 (54.3)	25 (0.98)	18.7 (0.74)	180 (7.1)	33.1 (1.3)	200 (7.9)	62.5 (2.5)
FB10a	3	1176 (46.3)	25 (0.98)	24.5 (0.96)	280 (11)	33.1 (1.3)	271 (10.7)	74.5 (2.93)
FB10b ⁽¹⁾	3	1150 (45.2)	15 (0.6)	15 (0.6)	277 (10.9)	35 (1.4)	277 (10.9)	35 (1.4)

1) Drilling template included in the shipment.

10.8.6.4 Drilling Patterns for Wall-mounted Frames (FK03–FK12)

Table 69: Drilling Pattern Dimensions for Wall-mounted Frames (FK03–FK12)

Frame	Drilling pattern	A [mm (in)]	A1 [mm (in)]	A2 [mm (in)]	B [mm (in)]	B1 [mm (in)]	C [mm (in)]	C1 [mm (in)]
FK03 ⁽¹⁾	2	460 (18.11)	8 (0.32)	7.5 (0.3)	150 (5.91)	12.4 (0.49)	–	–
FK05 ⁽¹⁾	2	557 (21.93)	8 (0.32)	10 (0.39)	187 (7.36)	10.5 (0.41)	–	–
FK06	2	535 (21.1)	12 (0.47)	8 (0.32)	170 (6.69)	19.5 (0.77)	–	–
FK07	2	580 (22.8)	12 (0.47)	8 (0.32)	200 (7.9)	19.5 (0.77)	–	–
FK08	2	721 (28.4)	12 (0.47)	10 (0.39)	200 (7.9)	33.5 (1.3)	–	–
FK09a	3	944 (37.2)	25 (0.98)	20 (0.79)	180 (7.1)	33.1 (1.3)	200 (7.9)	63.5 (2.5)
FK09c	3	1380 (54.3)	25 (0.98)	18.7 (0.74)	180 (7.1)	33.1 (1.3)	200 (7.9)	62.5 (2.5)
FK10a	3	1176 (46.3)	25 (0.98)	24.5 (0.96)	280 (11)	33.1 (1.3)	271 (10.7)	74.5 (2.93)
FK10b ⁽¹⁾	4	1150 (45.2)	15 (0.6)	15 (0.6)	277 (10.9)	35 (1.4)	277 (10.9)	35 (1.4)

1) Drilling template included in the shipment.

10.8.6.5 Drilling Patterns for Free-standing Frames (FK10c/FB10c, FK11/FB11, FK12/FB12)

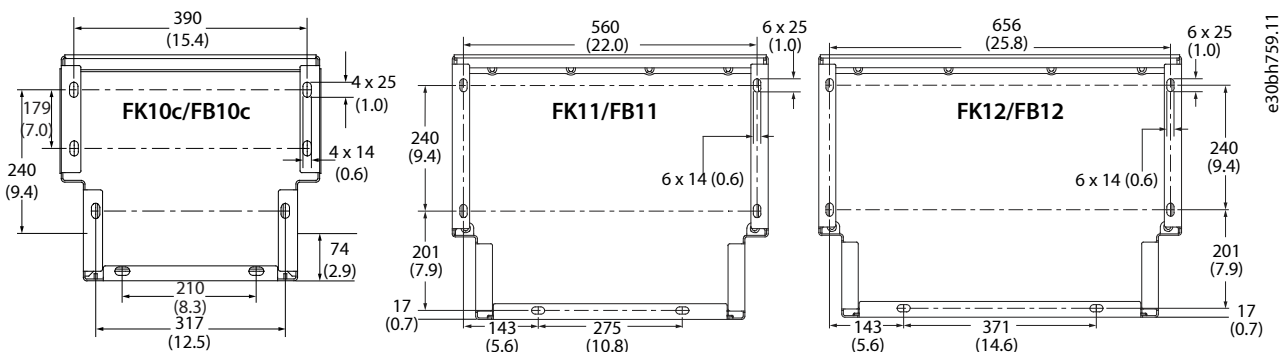

Figure 79: Drilling Patterns for Cable Openings in the Cable Entry Plate (FK10c/FB10c, FK11/FB11, FK12/FB12)

10.8.7 Placement of the Drive in the Installation

Before mounting the drive, prepare the mounting location with appropriate fasteners so the drive can be positioned safely. Make sure that there is enough space to handle the drive safely during installation. The center of gravity for each frame is shown in the drawings in chapter [Exterior and Terminal Dimensions](#).

Frames FA02–FA05, FK03, FB03, FK05, and FB05 can be lifted and mounted without lifting equipment by 1 or 2 persons. Check the weight on the packaging of the drive. All screws can be fitted before mounting the drive on the screws and tightening them.

When installing frames Fx06–Fx10, lift the drive using the lifting eyes as shown in [Figure 80](#). Ensure proper space for access of lifting tools at installation.

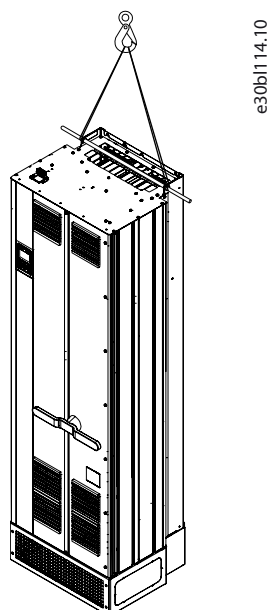

Figure 80: Lifting the Fx06–Fx10 Frames Using Lifting Eyes

Lower screws or bolts can be mounted before installation. Position the drive on the lower bolts, and mount the upper screws or bolts.

When installing frames Fx11–Fx12, lift the drive using the lifting eyes (see [Figure 81](#)). To avoid bending the lifting holes, use a bar.

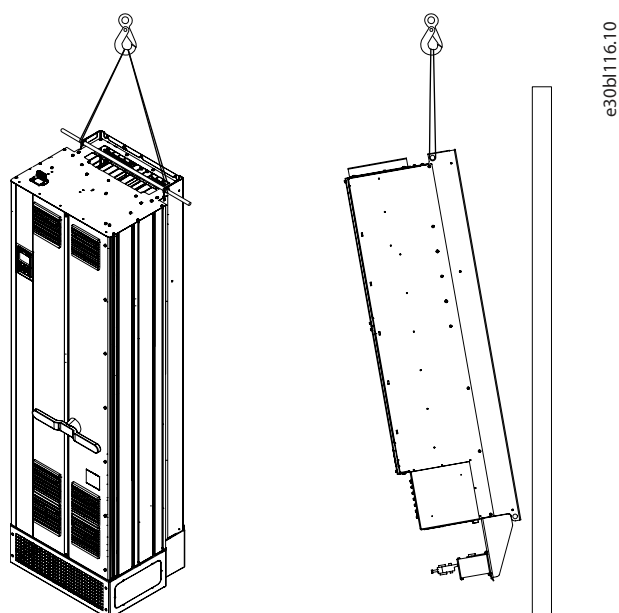

Figure 81: Lifting the Fx11–Fx12 Frames Using a Lifting Bar

Mount bolts for the lower part of the drive before mounting. Upper bolts are mounted when the drive is placed on the lower bolts, and placed towards the wall. If mounted on a pedestal, fix the pedestal to the floor before placing the drive on the pedestal.

10.8.8 Cooling

10.8.8.1 Overview of Cooling

All frequency converters are cooled by forced airflow. Frames Fx09–Fx12 have back-channel cooling, which makes installation of the drive more flexible.

For all installations, the temperature of the installation site must be kept within the specified operating temperature range by ventilation or cooling. The quality of the cooling air must comply with the environmental conditions as defined in the technical specifications (dust, airborne particles, chemical substances).

For more information on power loss and required cooling airflow, see [8.6.1.2 Power Loss, 6-pulse Frequency Converters](#) and [8.6.2 Airflow and Noise Levels](#).

10.8.8.2 Forced Air Cooling

All drives are air-cooled by forced airflow. For proper cooling, ensure that there is sufficient clearance above and below the drive.

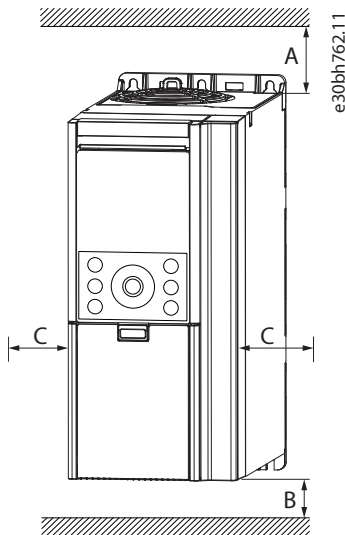

Figure 82: Clearance for Cooling

Table 70: Cooling Clearances for IP20/UL Open Type Frames

Frame	A [mm (in)]	B [mm (in)] ⁽¹⁾	C [mm (in)]
FA02	100 (3.9)	100 (3.9)	0 (0)
FA03	100 (3.9)	100 (3.9)	0 (0)
FA04	100 (3.9)	100 (3.9)	0 (0)
FA05	100 (3.9)	100 (3.9)	0 (0)
FA06	200 (7.9)	200 (7.9)	0 (0)
FA07	200 (7.9)	200 (7.9)	0 (0)
FA08	200 (7.9)	200 (7.9)	0 (0)
FA09	225 (8.9)	225 (8.9)	0 (0)
FA10	225 (8.9)	225 (8.9)	0 (0)
FA10b	225 (8.9)	225 (8.9)	0 (0)

Table 70: Cooling Clearances for IP20/UL Open Type Frames - (continued)

Frame	A [mm (in)]	B [mm (in)] ⁽¹⁾	C [mm (in)]
FA11	225 (8.9)	225 (8.9)	0 (0)
FA12	225 (8.9)	225 (8.9)	0 (0)

1) Distance does not include the EMC plate.

Table 71: Cooling Clearances for IP21/UL Type 1 Frames

Frame	A [mm (in)]	B [mm (in)] ⁽¹⁾	C [mm (in)]
FK03	200 (7.9)	200 (7.9)	0 (0)
FK05	200 (7.9)	200 (7.9)	0 (0)
FK06	200 (7.9)	200 (7.9)	0 (0)
FK07	200 (7.9)	200 (7.9)	0 (0)
FK08	200 (7.9)	200 (7.9)	0 (0)
FK09	225 (8.9)	225 (8.9)	0 (0)
FK10a	225 (8.9)	225 (8.9)	0 (0)
FK10b	225 (8.9)	225 (8.9)	0 (0)
FK10c	225 (8.9)	–	0 (0)
FK11	225 (8.9)	–	0 (0)
FK12	225 (8.9)	–	0 (0)

1) Distance does not include the EMC plate.

Table 72: Cooling Clearances for IP54/IP55/UL Type 12 Frames

Frame	A [mm (in)]	B [mm (in)] ⁽¹⁾	C [mm (in)]
FB03	200 (7.9)	200 (7.9)	0 (0)
FB05	200 (7.9)	200 (7.9)	0 (0)
FB06	200 (7.9)	200 (7.9)	0 (0)
FB07	200 (7.9)	200 (7.9)	0 (0)
FB08	200 (7.9)	200 (7.9)	0 (0)
FB09	225 (8.9)	225 (8.9)	0 (0)
FB10a	225 (8.9)	225 (8.9)	0 (0)
FB10b	225 (8.9)	225 (8.9)	0 (0)
FB10c	225 (8.9)	–	0 (0)
FB11	225 (8.9)	–	0 (0)
FB12	225 (8.9)	–	0 (0)

1) Distance does not include the EMC plate.

10.8.8.3 Back-channel Cooling

Back-channel cooling directs the heat out of the cabinet or room either by using closed air ducts or dedicated openings. Back-channel cooling applies to frames Fx09–Fx12.

A drive installed in a cabinet uses closed air ducts to minimize the heat dissipated inside the cabinet. The ducts direct external cooling air to the drive and out of the installation cabinet. The reduced heat dissipation minimizes the need for extra ventilation or cooling of the cabinet.

Cooling air can also be directed from outside a room to the drive heat sink. Heated air is vented to the outside of the drive. The top and bottom cooling openings of the drive are closed by covers, and cooling air is redirected out from the back of the drive.

See [Figure 83](#) for an example of cooling through air ducts and openings from the back of the drive.

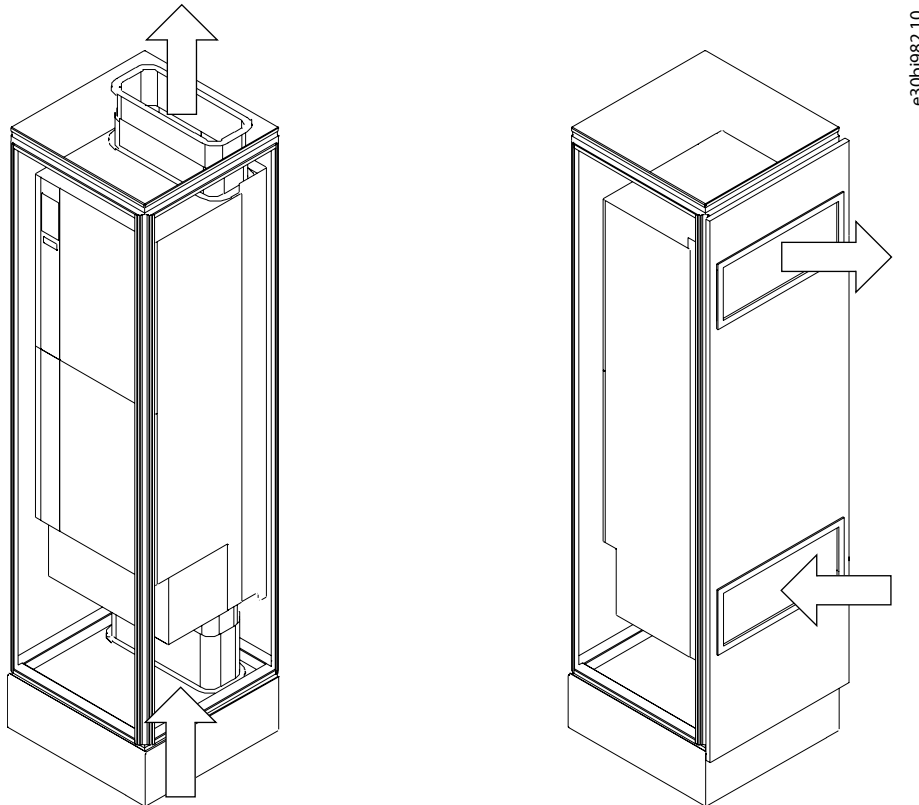

Figure 83: Examples of Back-channel Cooling Principles: Bottom-in, Top-out Cooling through Air Ducts (Left), Back-in, Back-out Cooling through Openings in the Back of the Drive (Right)

Back-channel cooling kits are available for IP20/UL Open Type frames (FA09–FA12). The kits make it easier to install drives in standard industrial frames such as Rittal. Back-channel cooling kits are also available for IP21/UL Type 1 frames (FK09–FK12) and IP54/IP55/UL Type 12 frames (FB09–FB12).

For more information on available cooling kits, see [12.4 Ordering Options and Accessories](#).

10.8.9 Recommended Space for Service Access

To ensure access to the drive for service and maintenance, it is recommended to reserve sufficient space around the drive.

The general recommendations include:

- Enough space in the front of the drive for removing covers, and access to the control board and installed options from the front.
- Enough space above the drive to access and remove fans for cleaning or service.
- Enough space below the drive to access the cooling channel entry to clean and remove pluggable connectors (FA02–FA05), and to mount EMC plates (FA02–FA12).

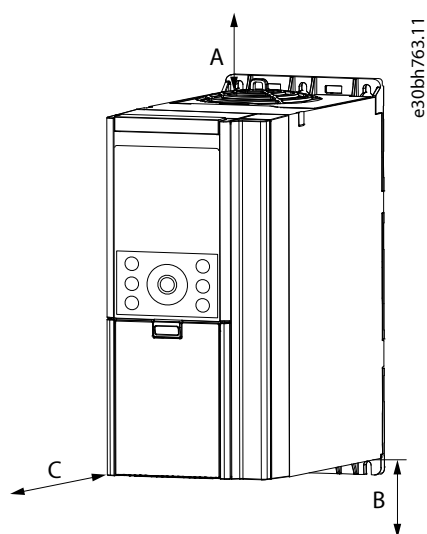

Figure 84: Recommended Clearance for Service Access

Table 73: Clearances for Service Access

Frame ⁽¹⁾	Recommended space for access		
	Above (A) [mm (in)]	Below (B) [mm (in)]	Front (C) [mm (in)]
FA02	200 (7.9) ⁽²⁾	200 (7.9) ⁽²⁾	100 (3.9)
FA03	200 (7.9) ⁽²⁾	200 (7.9) ⁽²⁾	100 (3.9)
FK03	200 (7.9)	200 (7.9)	400 (15.7)
FB03	200 (7.9)	200 (7.9)	400 (15.7)
FA04	200 (7.9) ⁽²⁾	200 (7.9) ⁽²⁾	100 (3.9)
FA05	200 (7.9) ⁽²⁾	200 (7.9) ⁽²⁾	100 (3.9)
FK05	200 (7.9)	200 (7.9)	400 (15.7)
FB05	200 (7.9)	200 (7.9)	400 (15.7)
Fx06	200 (7.9)	200 (7.9)	400 (15.7) ⁽³⁾
Fx07	200 (7.9)	200 (7.9)	400 (15.7) ⁽³⁾
Fx08	250 (9.8)	300 (11.8)	400 (15.7) ⁽³⁾
Fx09	225 (8.8)	225 (8.8)	400 (15.7) ⁽⁴⁾
Fx10	225 (8.8)	225 (8.8)	600 (23.6) ⁽⁴⁾
Fx11	225 (8.8)	225 (8.8)	800 (31.5) ⁽⁴⁾
Fx12	225 (8.8)	225 (8.8)	800 (31.5) ⁽⁴⁾

1) When referring to the entire series instead of a specific variant, Fx is used. For example, when describing FA02 and FK02 as a series, Fx02 is used.

2) Sufficient space to the cooling duct, exceeding the need for cooling. Alternatively, unplug the drive, and remove it from the installation for service.

3) Clearance needed for removing the cover.

4) Clearance needed for opening the door.

11 Electrical Installation Considerations

11.1 Wiring Diagram for the Standard Control Board (B5S, B5E)

This chapter gives a brief overview of the typical connections of a variable frequency drive. See [Figure 85](#) for a principle diagram of the drive. The drive is built around a power unit, a control unit, and optional I/O options. The exact configuration depends on the drive model.

1

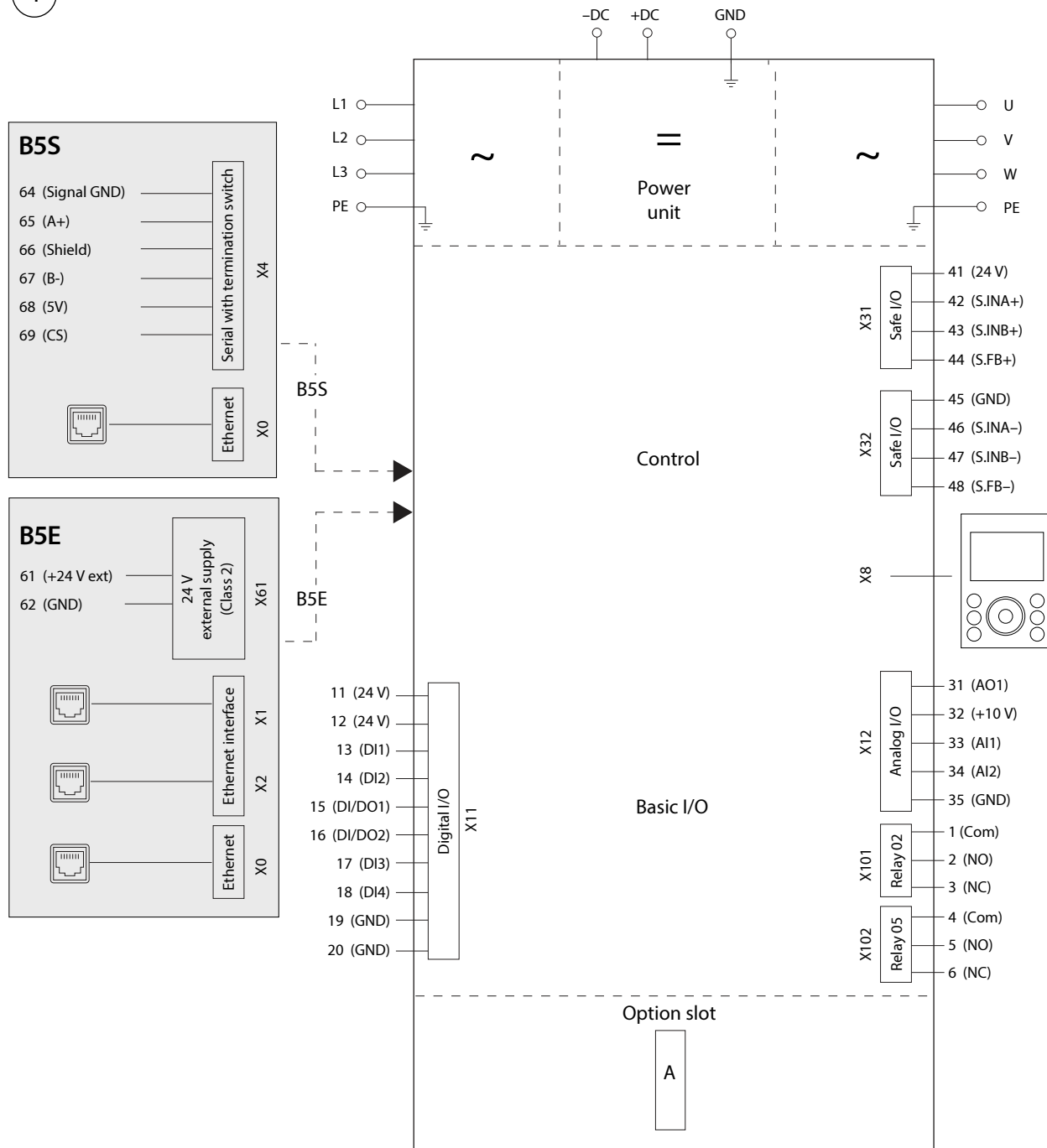

Figure 85: Wiring Diagram for Drives with the Standard Control Board (B5S, B5E)

11.2 Wiring Diagram for the Advanced Control Board (A5S, A5E)

This chapter gives a brief overview of the typical connections of a drive. See [Figure 86](#) for a principle diagram of the drive. The drive is built around a power unit, a control unit, and optional I/O options. The exact configuration depends on the drive model.

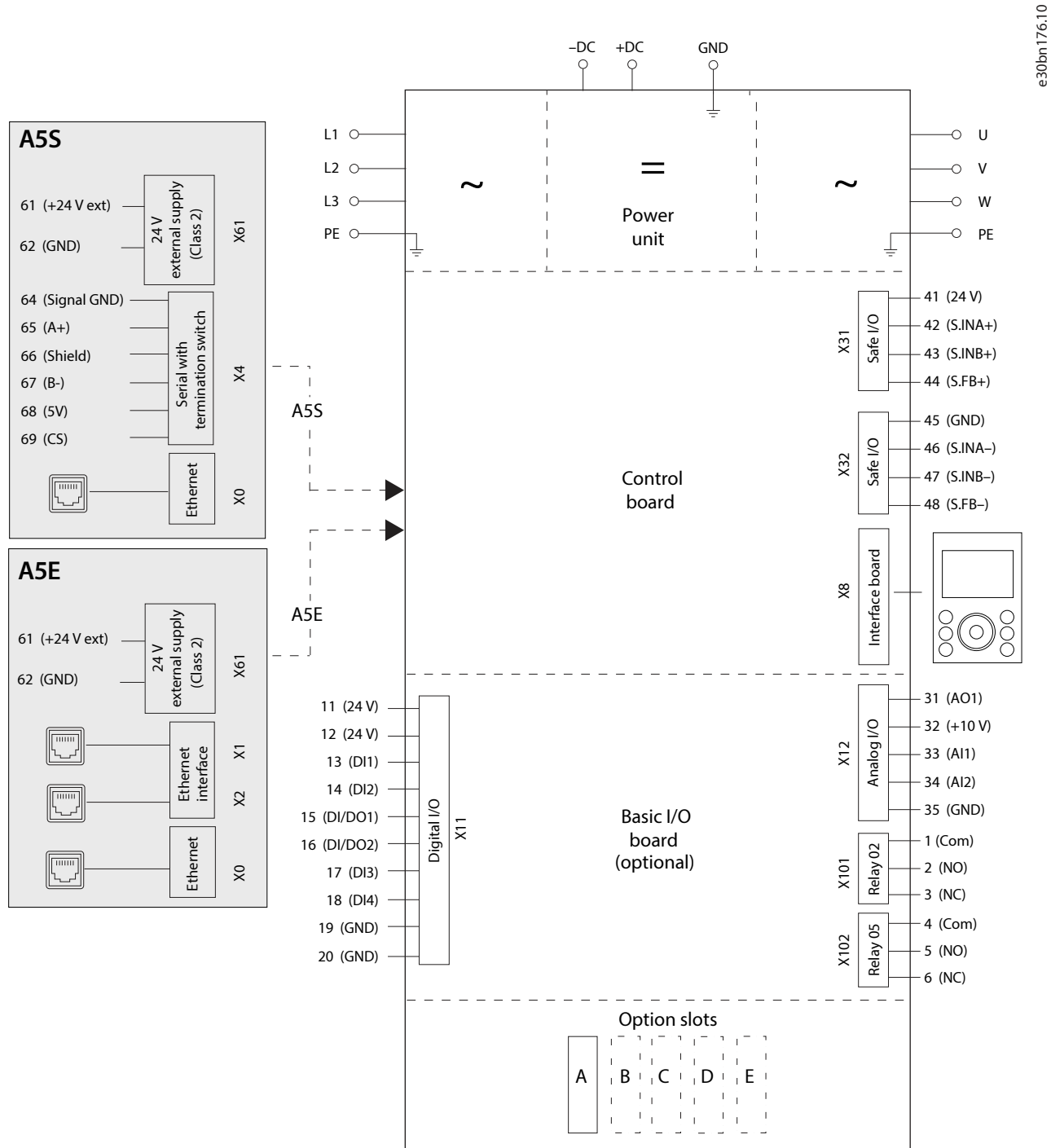

Figure 86: Wiring Diagram for Drives with the Advanced Control Board (A5S, A5E)

11.3 Grid Type and Protection

11.3.1 Grid Types

The drive can operate in different network types with rated network supply voltage:

- TN-S, TN-C, TN-C-S, TT (grounded delta)
- IT (ungrounded delta)

For detailed information about the parameters related to grid types, refer to the application guide.

11.3.2 Currents on Protective Earth and Potential Equalization/Leakage Currents

A properly dimensioned protective earth (PE) setup is essential for the safety of the drive system protecting against electric shock. The PE connections of the drive installation ensure that the drive system remains safe preventing that single fault currents generate hazardous voltages on accessible conductive parts, such as conductive enclosure parts.

The drive must be installed according to the requirement for PE connection and supplementary protective bonding as specified in EN 60364-5-54:2011 cl. 543 and 544. For the automatic disconnection if there is a fault at the motor side, it must be ensured that the impedance of the PE connection between drive and motor is sufficiently low to ensure compliance to IEC/EN 60364-4-41:2017 cl. 411 or 415. The impedance must be verified by initial and periodic test according to IEC/EN 60364-4-41:2017.

Local requirements may also apply.

Designing the system according to IEC/EN 61800-5-1:2017 ensures the suitability for the connection of PE and protective bonding of accessible conductive parts according to EN 60364-5-54:2011. When the drive is used as a component inside specific applications, special requirements for the proper connection to the PE, for example, those specified in EN 60204-1:2018 and IEC/EN 61439-1:2021, can apply.

In low-voltage networks, currents can arise on the protective conductor (PE) and equipotential bonding conductors and structures connected to ground potential as an undesirable effect. Since there are different causes for these currents, it is beneficial to know them to avoid them.

A drive setup consists of a mains supply, the drive inverter, its cabling, and a motor with the load side. Due to the behavior of the active and passive components, and the electrical setup of the installation, several phenomena may appear resulting in currents on the PE conductor.

- Inductive coupling due to asymmetry in mains cables and/or busbars can cause PE current at the mains frequency and its harmonics.
- Inductive coupling due to asymmetry in motor cables can cause PE current at the motor fundamental frequency.
- As part of the EMI filter DC link, capacitive decoupling to PE can cause PE currents at 150 Hz/180 Hz.
- Voltage distortion/harmonic content on the mains can typically cause PE currents in the 150 Hz–2000 Hz range.
- Common-mode currents due to motor cable capacitance from motor phases to PE typically result in PE currents at the switching frequency and harmonics typically above 2 kHz.

The PE current is made up of several contributions and depends on various system configurations:

- RFI filtering
- Motor cable length
- Motor cable shielding
- Drive power

11.3.3 PE Current Measurement

As the currents have different frequencies, it is not useful to measure an effective value only. Instead, it is required to perform a frequency/FFT measurement. This can be done by using an appropriate oscilloscope or specific measuring equipment. Just analyzing the effective value with a current clamp at the PE connection of the drive leads to insufficient and misleading results.

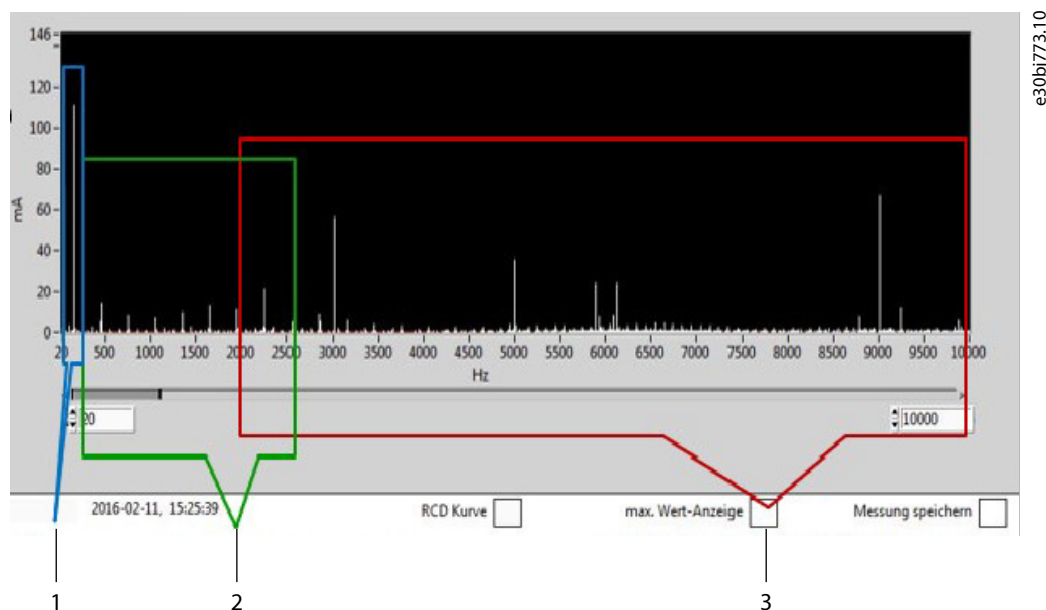

Figure 87: Example of FFT Measurement

- | | |
|--|---|
| <p>1 $f < 50$ Hz: Typical for inductive coupling in unsymmetrical cables and conductor.</p> | <p>2 $f = 150\text{--}2500$ Hz: Typical harmonic components in grid.
$f = 150$ Hz: Common-mode current typical due to rectifier with DC link.</p> |
| <p>3 $f > 2$ kHz: Typical common-mode current due to capacitive coupling between cable/motor and ground.</p> | |

WARNING



ELECTRICAL SHOCK HAZARD - LEAKAGE CURRENT HAZARD

Leakage currents exceed 3.5 mA. Failure to connect the drive properly to protective earth (PE) can result in death or serious injury.

- Ensure reinforced protective earthing conductor according to IEC 60364-5-54 cl. 543.7 or according to local safety regulations for high touch current equipment. The reinforced protective earthing of the drive can be done with:
 - a PE conductor with a cross-section of at least 10 mm^2 (8 AWG) Cu or 16 mm^2 (6 AWG) Al.
 - an extra PE conductor of the same cross-sectional area as the original PE conductor as specified by IEC 60364-5-54 with a minimum cross-sectional area of 2.5 mm^2 (14 AWG) (mechanically protected) or 4 mm^2 (12 AWG) (not mechanically protected).
 - a PE conductor completely enclosed with an enclosure or otherwise protected throughout its length against mechanical damage.
 - a PE conductor part of a multi-conductor power cable with a minimum PE conductor cross-section of 2.5 mm^2 (14 AWG) (permanently connected or pluggable by an industrial connector. The multi-conductor power cable shall be installed with an appropriate strain relief).
 - NOTE: In IEC/EN 60364-5-54 cl. 543.7 and some application standards (for example IEC/EN 60204-1), the limit for requiring reinforced protective earthing conductor is 10 mA leakage current.

 **WARNING**

LEAKAGE CURRENT HAZARD

Leakage currents can exceed 5%. Failure to ground the drive properly can result in death or serious injury.

- Ensure that the minimum size of the ground conductor complies with the local safety regulations for high touch current equipment.

Protective earth (PE) and equipotential bonding are usually connected to one another so that equipotential bonding currents are also distributed over the entire PE system.

PE currents and their impact on the system can be avoided or reduced by using short motor cables, symmetrical cables (especially for current ratings > 50 A), or shielded cables with low capacitance between conductors and PE.

11.3.4 Residual Current Device (RCD) Protection

Residual current devices (RCD) may be used to provide additional protection against electric shock and fire hazards due to fault currents because of insulation faults or high leakage currents. Additional consideration is needed when RCDs are used in front of the drive. RCDs must always be installed according to local regulations.

 **WARNING**



ELECTRIC SHOCK AND FIRE HAZARD – RCD COMPLIANCE

Failure to use a Type B residual current-operated protective device (RCD) can lead to the RCD not providing the intended protection and therefore can result in death, fire, or other serious hazard.

- When an RCD is used for protection against electrical shock or against fire, only a Type B device is allowed on the supply side.

RCD/RCM devices cannot differentiate between operating and fault currents, and their function can be impaired. RCDs can be triggered even though there is no insulation fault in the installation.

The current measured by an RCD/RCM on mains phases might differ from the measured PE current. This is due to magnetic coupled PE current not being present on mains phases.

The frequency characteristic of Type B RCDs is not completely standardized, and vendor-specific differences are to be expected in the upper frequency range. Consult the documentation of the RCD in question for more information.

11.3.5 Isolation Monitoring Devices

When operating on an IT grid, isolation monitoring devices can be used for observing the integrity of the isolation in the supply cabling, motor, motor cabling, and the drive.

The typical applications are:

- Preventive detection of degradation of the isolation system.
- Ground fault detection on IT mains.

The isolation monitor is a key component in an IT mains installation. It allows preventive maintenance and warns whenever a ground fault occurs. Several types of isolation monitors exist with different operation principles, for example, DC-voltage injection, DC voltage with alternating polarity injection and current injection. Not all isolation monitors are compatible with drive systems due to capacitances to ground and drives producing common-mode voltages. It is essential that the isolation monitor used in a drive system installation is compatible with drives.

11.4 EMC-compliant Installation Guidelines

11.4.1 Overview

This chapter gives a general introduction to proper EMC-compliant installation practice. To obtain an EMC-compliant installation, follow the instructions provided in the installation and safety guides supplied with the drive.

NOTICE

According to the EMC Directive, a system is defined as a combination of several types of equipment, finished products, and/or components combined, designed and/or put together by the same person (system manufacturer) intended to be placed on the market for distribution as a single functional unit for an end user and intended to be installed and operated together to perform a specific task.

The EMC directive applies to products/systems and installations, but in case the installation is built up of CE-marked products/systems, the installation can also be considered compliant with the EMC directive. Installations are not CE-marked.

According to the EMC Directive, as a manufacturer of products/systems is responsible for obtaining the essential requirements of the EMC directive and attaching the CE mark. For systems involving load sharing and other DC terminals, Danfoss can only ensure compliance with the EMC Directive when combinations of Danfoss products are connected as described in the technical documentation.

If any third-party products are connected to the load share or other DC terminals on the drives, Danfoss cannot guarantee that the EMC requirements are fulfilled.

If installed in residential environments, and not compliant to category C1, the drive may not provide adequate protection to radio reception in such locations. In such cases, supplementary mitigation measures might be required, for example, the use of shielding or increasing the distance between affected products.

If not compliant to category C1 or C2, the drive must not be installed in a public low-voltage network, which supplies residential premises. Radio frequency interference can be expected if used on such a network. Follow the instructions for installation given in the product-specific installation guide.

If the RFI filters of the drive are disabled, the drive fulfills category C4. In this case, the drive is intended to be used in an installation powered by a supply which does not radiate, for example, a dedicated transformer or generator, or low-voltage underground lines. If guidelines for installation are not followed carefully, radio frequency interference can be expected.

See [Figure 88](#) for an example of how to ensure a proper EMC-compliant installation.

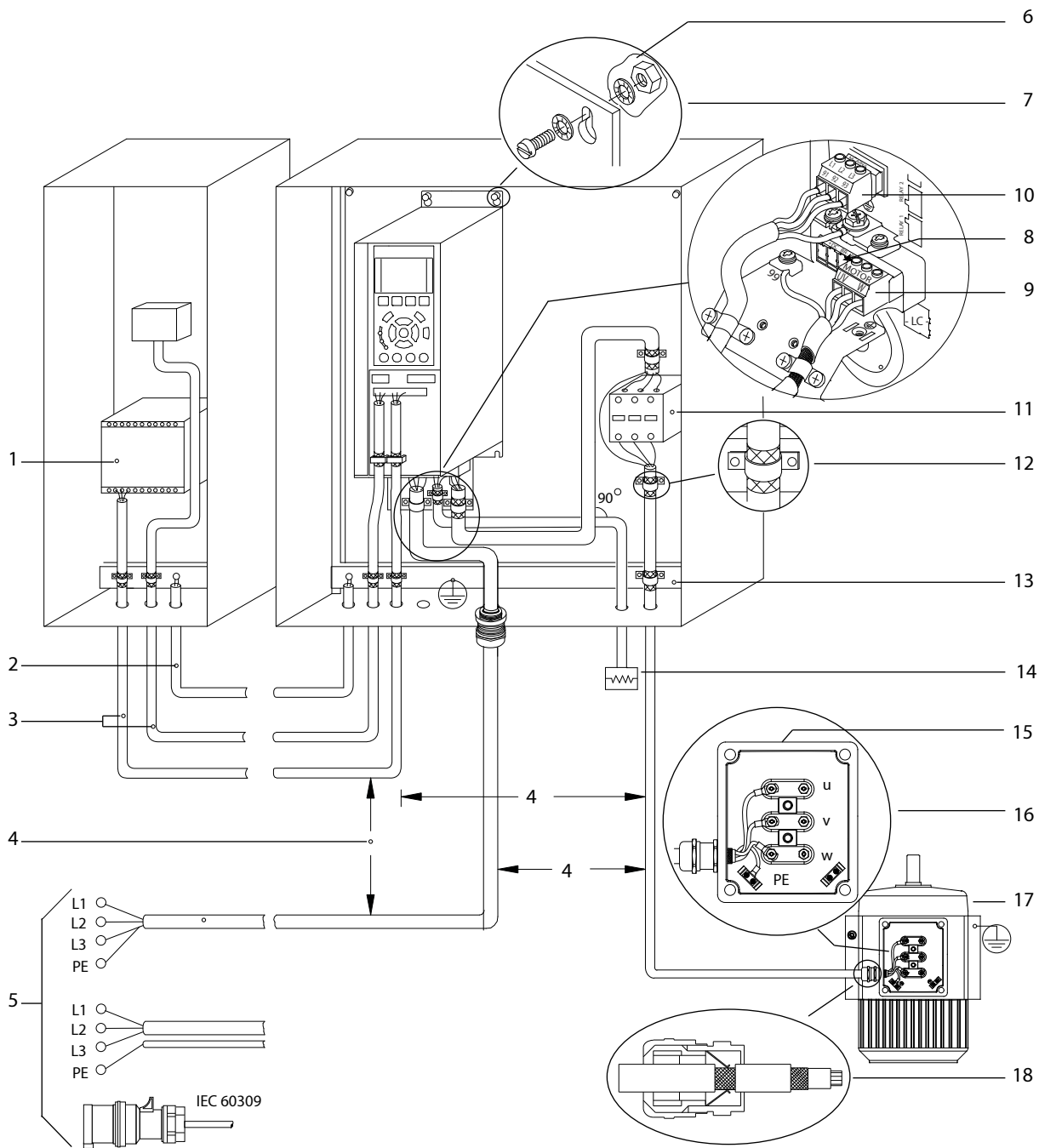

Figure 88: Example of Proper EMC Installation

1	Programmable logic controller (PLC)	2	Minimum 16 mm ² (6 AWG) equalizing cable
3	Control cables	4	Minimum 200 mm (7.9 in) between control cables, motor cables, and mains cables
5	Mains supply options, see IEC/EN 61800-5-1	6	Bare (unpainted) surface
7	Star washers	8	Brake cable (shielded) – not shown, but the same grounding principle applies as for motor cable
9	Motor cable (shielded)	10	Mains cable (unshielded)
11	Output contactor	12	Cable insulation stripped

13	Common ground busbar. Follow local and national requirements for cabinet grounding.	14	Brake resistor
15	Terminal box	16	Connection to motor
17	Motor	18	EMC cable gland

11.4.2 Power Cables and Grounding

Depending on the installation and the required EMC compliance level, using shielded cables is required for motor, brake, and DC connections. Alternatively, unshielded cables within a metal conduit can also be used.

If a shielded cable is used, it is important to connect the shield through a 360° connection. Connect the shield with the supplied clamps, and avoid pigtailed, as they limit the shielding functionality.

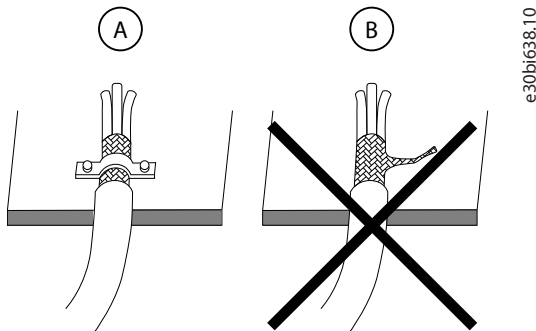

Figure 89: Installation of Cable Shield

NOTICE

SHIELDED CABLES

If shielded cables or metal conduits are not used, the unit and the installation do not meet regulatory limits.

If a non-shielded wire is used to connect a brake resistor, it is recommended to twist the wires to reduce the electric noise.

Ensure that the cables are as short as possible to reduce interference level from the entire system and minimize losses.

⚠ WARNING



ELECTRICAL SHOCK HAZARD - LEAKAGE CURRENT HAZARD

Leakage currents exceed 3.5 mA. Failure to connect the drive properly to protective earth (PE) can result in death or serious injury.

- Ensure reinforced protective earthing conductor according to IEC 60364-5-54 cl. 543.7 or according to local safety regulations for high touch current equipment. The reinforced protective earthing of the drive can be done with:
 - a PE conductor with a cross-section of at least 10 mm² (8 AWG) Cu or 16 mm² (6 AWG) Al.
 - an extra PE conductor of the same cross-sectional area as the original PE conductor as specified by IEC 60364-5-54 with a minimum cross-sectional area of 2.5 mm² (14 AWG) (mechanically protected) or 4 mm² (12 AWG) (not mechanically protected).
 - a PE conductor completely enclosed with an enclosure or otherwise protected throughout its length against mechanical damage.
 - a PE conductor part of a multi-conductor power cable with a minimum PE conductor cross-section of 2.5 mm² (14 AWG) (permanently connected or pluggable by an industrial connector. The multi-conductor power cable shall be installed with an appropriate strain relief).
- NOTE: In IEC/EN 60364-5-54 cl. 543.7 and some application standards (for example IEC/EN 60204-1), the limit for requiring reinforced protective earthing conductor is 10 mA leakage current.

Ground the drive according to applicable standards and directives. Use a dedicated ground wire for input power, motor power, and control wiring. Terminate individual ground wires separately, complying with the dimension requirements.

Follow motor manufacturers wiring requirements when connecting to the motors.

Keep the grounding wire as short as possible. The minimum cable cross-section for the ground wires is 10 mm² (7 AWG). Alternatively, it is possible to use 2 rated ground wires terminated separately. Do not ground drives to each other in a daisy-chain fashion (see [Figure 90](#)).

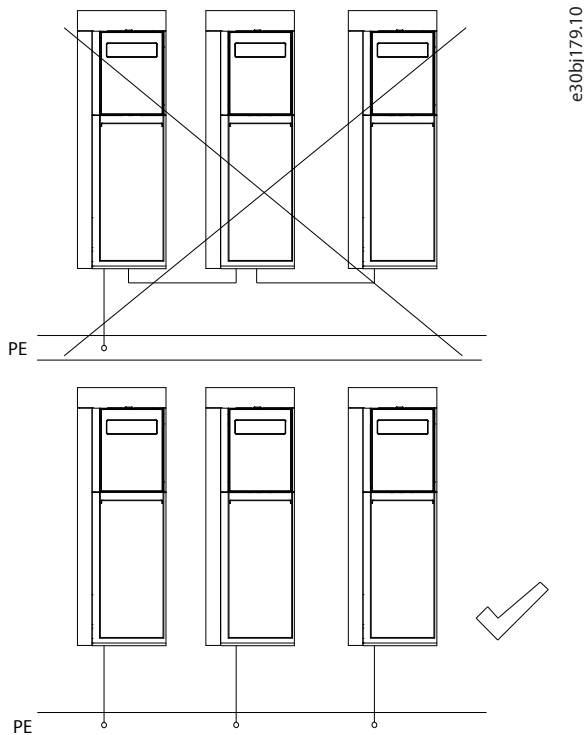

Figure 90: Grounding Principle

11.4.3 Control Cables

Use shielded cables for control wiring and avoid placing control wires next to power cables. Ideally, isolate the control cables from the power cables (mains, motor, brake, and DC) by routing them separately or keep a minimum distance of 200 mm (7.9 in). For optional shielding, both ends of the shielded control cables must have the shield connected.

Keep 24 V signal cables apart from 110 V or 230 V signals from relays, for example.

When the drive is connected to a thermistor, ensure that the wiring is shielded and reinforced/double isolated. A 24 V DC supply voltage is recommended.

For communication purpose and command/control lines, follow the particular protocol standard.

11.5 Motor Installation Considerations

11.5.1 Overview

When selecting a variable frequency drive, consider the following aspects:

- **Torque limits:** When a drive controls a motor, torque limits can be set for that motor. Selecting a frequency converter with an apparent power rating that matches the rated current or power of the motor ensures that the required load can be driven reliably. However, an extra reserve is necessary to enable smooth acceleration of the load and also cater for occasional peak loads.
- **Current ratings** of the drive and the motor. Power rating is only a rough guide.
- Correct **operating voltage**.
- Ensure that the motor withstands the **maximum peak voltage** on the motor terminals.
- **Required speed range:** Operation above the nominal motor supply frequency (50 Hz or 60 Hz) is possible only at reduced power. Operation at low frequency and high torque can cause the motor to overheat due to lack of cooling.
- **Derating:** Synchronous motors require derating, typically by 2–3 times, because the power factor, and hence the current, can be high at low frequency.
- **Overload performance:** Depending on drive settings, the drive limits the current to 130–140% of the full current in low-overload mode, and up to 170% of the full current in high-overload mode. A standard, fixed-speed motor tolerates these overloads.
- The **direction of rotation** when connected to the frequency converter's output terminals U-V-W follows the specification from NEMA MG1 and IEC 60034-8. Ensure the correct direction of rotation in the end application to avoid a potentially hazardous situation. If only 1 direction of rotation is required, it is recommended to parameterize the drive to operate in the relevant direction only.

WARNING



INDUCED VOLTAGE

Induced voltage from output motor cables that run together or near other power cables can charge equipment capacitors, even with the mains power turned off and locked out. Failure to run output motor cables separately, or to use shielded cables, could result in death or serious injury.

- Install output motor cables in separate conduits or use shielded cables.

For the basics of protecting the motor insulation and bearings in drive systems, see [11.5.3 Motor Insulation](#) and [11.5.5 Bearing Currents](#).

11.5.2 Supported Motor Types

The iC7-Aqua drives are compatible with:

- Induction motors.
- Permanent magnet motors.

The drives are motor-independent and can be connected to any brand of motor. For instructions on how to set up motors, refer to the relevant application guide.

For detailed information about the supported motor types, contact Danfoss.

11.5.3 Motor Insulation

Because of rapid switching and reflections in the cables, motors are subject to more voltage stress in the windings when fed by variable frequency drives than with sinusoidal supply voltage.

Regardless of frequency, the drive output comprises pulses of approximately the drive DC-bus voltage with a short rise time. The pulse voltage can almost double at the motor terminals, depending on the attenuation and reflection properties of the motor cable and the terminals. This stresses the motor winding insulation and can cause it to break down, resulting in possible sparking.

Depending on voltage and cable length, a filter or reinforced insulation of the motor is required.

Table 74: Recommended Motor Winding Protection

Voltage (V)	Cable length (m [ft])	Protection
500–600	<150 (492)	Insulation and dU/dt filter
>600	<150 (492)	Insulation and dU/dt filter
>600	>150 (492)	Insulation

11.5.4 Parallel Motors

Many applications use more motors operating at the same speed. In some cases, 1 drive controls multiple motors. When controlling multiple motors, the following conditions must be fulfilled:

- All motors must operate at the same speed.
- The design must accommodate the drive as a single point of failure.
- All motors must be started simultaneously by the drive. If an additional motor is connected during the operation of motors, oversizing the drive might be needed to avoid overcurrent faults.

11.5.5 Bearing Currents

Variable frequency drives can cause common-mode voltages which induce voltages across motor bearings, leading to current flow through motor bearings. To protect against bearing currents, use either sine-wave filters, common-mode filters, or a combination of the two.

Two types of bearing current behaviors exist:

- Capacitive bearing behavior
- Resistive bearing behavior

The steep switching rate of the drive output voltage combined with the inherent common-mode voltage produced by the drive causes shaft voltage. Motor asymmetries, or the use of asymmetric motor cables especially in high-power applications where the motor current exceeds 100–200 A can also cause shaft voltage.

Bearing currents cannot be directly measured. Only rotor-to-ground can be measured to some extent. At motor sizes of 100 kW and up, it can be assumed that 10–30% of the measured common-mode current is bearing currents.

The bearing current type is a consequence of all elements in the installation, for example, the motor cable, drive, motor type and topology, shaft load and mechanical installation, and system grounding. The best way to control bearing currents is to combine common-mode filtering with a sine-wave filter, or to use an all-mode filter that significantly reduces bearing currents.

11.5.6 Motor Thermal Protection

During operation, the motor connected to the drive can be monitored to avoid overheating.

NOTICE**EXCESSIVE HEAT AND PROPERTY DAMAGE**

Overcurrent can generate excessive heat within the drive. Failure to provide overcurrent protection can result in risk of fire and property damage.

- Use additional protective devices such as short-circuit protection or motor thermal protection between drive and motor for applications with multiple motors.
- Input fusing is required to provide short-circuit and overcurrent protection. If fuses are not factory-supplied, the installer must provide them. Refer to the product-specific documentation for fuse specifications.

Depending on the criticality of overheating, different monitoring methods can be used:

- Built-in Electronic Thermal Motor monitoring
- External connected sensors (Pt, Ni, PTC, or KTY sensors)

For information on configuring the functionalities, refer to the application guide.

11.5.7 Electronic Thermal Relay Function

The electronic thermal relay (ETR) function protects the motor from thermal overload without connecting an external device by estimating the motor temperature based on present load and time.

The ETR function meets the relevant requirements of UL 61800-5-1, including the Thermal Memory Retention requirement, and ensures a class 20 protection level.

NOTICE**PROPERTY DAMAGE**

Protection against motor overload is not included in the default setting. The ETR function provides class 20 motor overload protection. Failure to set the ETR function means that motor overload protection is not provided and property damage can occur if the motor overheats.

- Enable the ETR function. Refer to the application guide for more information.

11.5.8 External Connected Sensors

Monitoring can be done by using analog input or digital inputs on the I/O board or with functional extension options. The sensors must be either double isolated or have reinforced insulation between motor and drive control.

The analog input allows measurement of the temperature by using external sensors.

Using a digital input allows monitoring with a PTC sensor. The PTC must be connected from 24 V DC to the digital input.

11.6 Power Cable Considerations

11.6.1 Overview

When selecting power cables, consider the following:

- All wiring must comply with local and national regulations regarding cross-section and ambient temperature requirements.
- Drives are designed for use with 70 °C (158 °F) rated copper cables for frames up to Fx07. For Fx08–Fx12, a 90 °C (194 °F) rated copper cable is recommended. Unless otherwise stated, the ambient temperature of the drive matches the cable rating.
- Aluminum cables can be used from 35 mm² onwards. Proper connections must be secured by removing the oxide layer and applying joint compound.
- Cable lugs are required for the PE wire for frames FA02–FA05.

For details on power connector sizing, see [8.5 Dimensioning of Power Cables](#). The dimensions apply to both solid and stranded cables.

11.6.2 Torque Requirements

Connections must be tightened with the correct torque. See [Table 75](#), [Table 76](#), and [Table 77](#).

Table 75: Torque Requirements for IP20/UL Open Type Frames

Frame	Mains/Motor [Nm (in-lb)]	DC [Nm (in-lb)]	PE/Ground connection [Nm (in-lb)]
FA02	0.7 (6.2)	0.7 (6.2)	2–3 (17.7–26.5)
FA03	0.7 (6.2)	0.7 (6.2)	2–3 (17.7–26.5)
FA04	1.2–1.5 (10.6–13.3)	1.2–1.5 (10.6–13.3)	2–3 (17.7–26.5)
FA05	2.0–2.5 (17.7–22.1)	2.0–2.5 (17.7–22.1)	2–3 (17.7–26.5)
FA06	14 (124)	14 (124)	2–3 (17.7–26.5)
FA07	14 (124)	14 (124)	2–3 (17.7–26.5)
FA08	20 (177)	14 (124)	2–3 (17.7–26.5)
FA09	19 (168)	19 (168)	9.6 (84)
FA10	19 (168)	19 (168)	19 (168)
FA11	19 (168)/35 (310)	19 (168)	9.6 (84)/19 (168)
FA12	19 (168)/35 (310)	19 (168)	9.6 (84)/19 (168)

Table 76: Torque Requirements for IP21/UL Type 1 Frames

Frame	Mains/Motor [Nm (in-lb)]	DC [Nm (in-lb)]	PE/Ground connection [Nm (in-lb)]
FK03	1.2 (11)	1.2 (11)	2–3 (17.7–26.5)
FK05	1.2–1.5 (11-15)	1.2–1.5 (11-15)	2–3 (17.7–26.5)
FK06	14 (124)	14 (124)	2–3 (17.7–26.5)
FK07	14 (124)	14 (124)	2–3 (17.7–26.5)
FK08	20 (177)	14 (124)	2–3 (17.7–26.5)
FK09 ⁽¹⁾	19 (168)	19 (168)	9.6 (84)
FK10 ⁽²⁾	19 (168)	19 (168)	9.6 (84)
FK11	19 (168)/35 (310)	19 (168)	19 (168)
FK12	19 (168)/35 (310)	19 (168)	19 (168)

1) Applies to both FK09a and FK09c.

2) Applies to both FK10a and FK10c.

Table 77: Torque Requirements for IP54/IP55/UL Type 12 Frames

Frame	Mains/Motor [Nm (in-lb)]	DC [Nm (in-lb)]	PE/Ground connection [Nm (in-lb)]
FB03	1.2 (11)	1.2 (11)	2–3 (17.7–26.5)
FB05	1.2–1.5 (11-15)	1.2–1.5 (11-15)	2–3 (17.7–26.5)
FB06	9 (80)	9 (80)	2–3 (17.7–26.5)
FB07	16 (142)	9 (80)	2–3 (17.7–26.5)
FB08	20 (177)	16 (142)	2–3 (17.7–26.5)
FB09	19 (168)	19 (168)	9.6 (84)

Table 77: Torque Requirements for IP54/IP55/UL Type 12 Frames - (continued)

Frame	Mains/Motor [Nm (in-lb)]	DC [Nm (in-lb)]	PE/Ground connection [Nm (in-lb)]
FB10	19 (168)	19 (168)	9.6 (84)
FB11	19 (168)/35 (310)	19 (168)	19 (168)
FB12	19 (168)/35 (310)	19 (168)	19 (168)

11.7 Control Connections

11.7.1 Overview

Examples are shown with the control board and the optional basic I/O board. Standard I/O configurations are described with references to functionalities and connector numbering. For detailed information on I/O performance, see chapter *General Technical Data*. For detailed information on addressing the I/O, refer to the relevant application guide.

Standard setup is for 24 V logic (NPN logic). Operation with reverse logic is set in the software. For the locations of all I/O connections of the control boards with the Ethernet interface (B5E, A5E), see [Figure 91](#).

The control connections in iC7-Aqua drives come in 3 different colors, each color indicating a different characteristic of the connector (see [Table 78](#)).

Table 78: Control Connector Colors

Color	Functionality
Gray	Low-voltage control (up to 24 V)
Black	Isolated I/O control that can support up to 250 V AC
Yellow	Functional safety

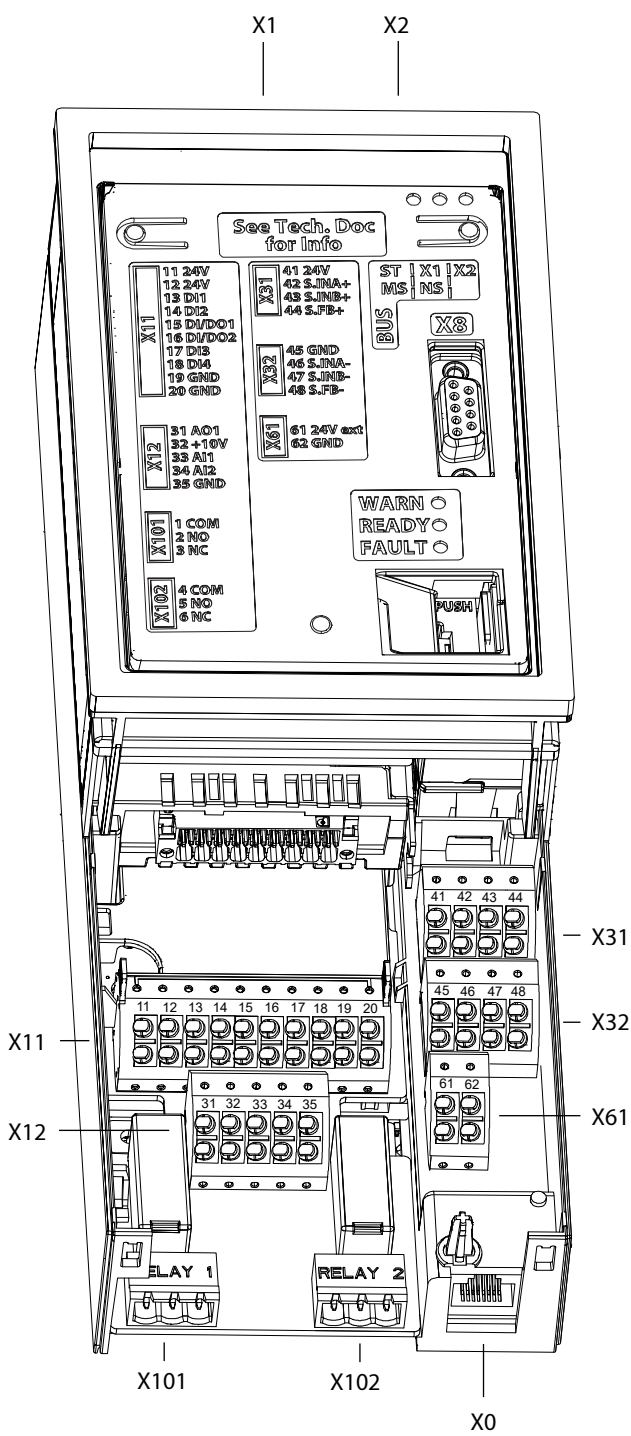

e30bi689.10

Figure 91: Location of Connections on the Standard Control Board (B5E) and Advanced Control Board (A5E) without Functional Extension Options

Table 79: I/O Connectors

Location	Connector name	Function	Color
Control board	X61	24 V external supply	Gray
Integrated or Basic I/O (+BDBA)	X11	Digital I/O connector	Gray
	X12	Analog I/O connector	Gray
	X101	Relay 2	Black
	X102	Relay 5	Black

The frequency converters can be equipped with 1–4 functional extension options. The number of options depends on the frame and the control board. For detailed information about the number of option slots in each frame, see [7.3.1 Overview](#).

11.7.2 Functional Safety I/Os (X31, X32)

The functional safety I/Os are configured for dual channel STO and STO feedback by default. To ensure correct installation, the I/O has 2 connectors that are not interchangeable.

If other functional safety functions than **STO, not upgradable (+BEG1)** have been selected in the drive configuration, the I/Os can be reconfigured. Use 24 V and GND from connectors X31/X32 when using the functional safety I/Os.

NOTICE

If **STO, not upgradable (+BEG1)** has been selected, the control board only supports hardwired STO, and cannot be reconfigured.

Table 80: Functional Safety I/O Functions

X31			X32		
Terminal	Terminal Name	Function	Terminal	Terminal Name	Function
41	24 V	+ 24 V DC Output	45	GND	0 V/GND
42	S.INA+	+ Safe Input Channel A	46	S.INA–	– Safe Input Channel A
43	S.INB+	+ Safe Input Channel B	47	S.INB–	– Safe Input Channel B
44	S.FB+	+ STO feedback	48	S.FB–	– STO Feedback

11.7.3 External 24 V Supply (X61)

An external 24 V DC supply can be connected to the control board in the standard control board B5E and advanced control boards A5S and A5E. If the mains supply is disconnected, the external 24 V supply allows continued operation of bus communication, built-in control programs, and control of I/Os.

Table 81: External 24 V (X61)

Terminal	Function
61	+24 V external supply
62	GND

11.7.4 Digital and Analog I/O (X11/X12)

Extra digital and analog I/Os are on the optional basic I/O board. See [Table 82](#) and [Table 83](#) for the configuration and supported functions of each I/O. For more information on the details of the functionalities, refer to the relevant application guide.

In drives with the advanced Ethernet-based control board (A5E), connector X11 covers digital I/O and pulse I/O. The standard setting is NPN logic (24 V), but can be changed by a parameter to PNP (negative logic).

Connector X12 supports analog I/O and temperature sensors.

Table 82: I/O Connector X11: Digital and Pulse I/O

Terminal number	Terminal name ⁽¹⁾	Function
11	–	+24 V
12	–	+24 V
13	T13	Digital input 1

Table 82: I/O Connector X11: Digital and Pulse I/O - (continued)

Terminal number	Terminal name ⁽¹⁾	Function
14	T14	Digital input 2
15	T15	Digital input/Digital output 1
16	T16	Digital input/Digital output 2 ⁽²⁾
17	T17	Digital input 3
18	T18	Digital input 4
19	–	GND
20	–	GND

1) The terminal name is used in application software to identify the terminal.

2) In drives with the advanced Ethernet-based control board, (A5E) Digital input/Digital output 2 also supports pulse output or pulse input.

Table 83: I/O Connector X12: Analog I/O

Terminal number	Terminal name	Function
31	T31	Analog output (0–10 V, 0/4–20 mA)
32	–	+10 V reference
33	T33	Analog input 1 (± 10 V ⁽¹⁾ , 0/4–20 mA)
34	T34	Analog input 2 (± 10 V ⁽¹⁾ , 0/4–20 mA)
35	–	GND

- 1) • Standard control boards A5S, B5E: +10 V
 • Advanced control boards A5S, A5E: ± 10 V

⚠ CAUTION

THERMISTOR INSULATION

Risk of personal injury or equipment damage.

- To meet the PELV insulation requirements, use only thermistors with reinforced or double insulation.

11.7.5 Relay (X101/X102)

There are 2 relays on the basic I/O board. Each relay is galvanically isolated from other controls, and can operate voltages up to 250 V. Relevant installation requirements must be observed.

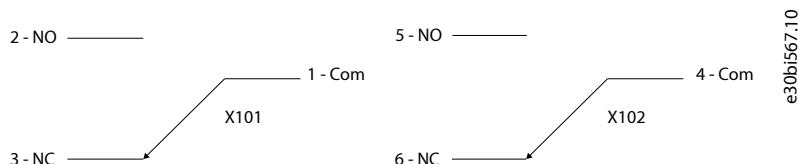

Figure 92: Relay X101 and X102 Functionality

Table 84: Connector X101 and X102 Functions

Terminal X101 (Terminal name: T2) ⁽¹⁾		Terminal X102 (Terminal name: T5) ⁽¹⁾	
Number	Function	Number	Function
1	Common	4	Common
2	Normally Open (NO)	5	Normally Open (NO)
3	Normally Closed (NC)	6	Normally Closed (NC)

1) The terminal name is used in application software to identify the terminal.

11.7.6 Communication Ports (X0, X1, X2, X4)

11.7.6.1 Overview

The locations of the communication ports depend on the frame. All connections are placed in the control board, but the wiring varies between different frames.

11.7.6.2 Communication Port Locations in FA02-FA12 Frames

Port X0 is on the control board as shown in [Figure 93](#). The port is typically used to connect to a PC or similar equipment to configure the drive.

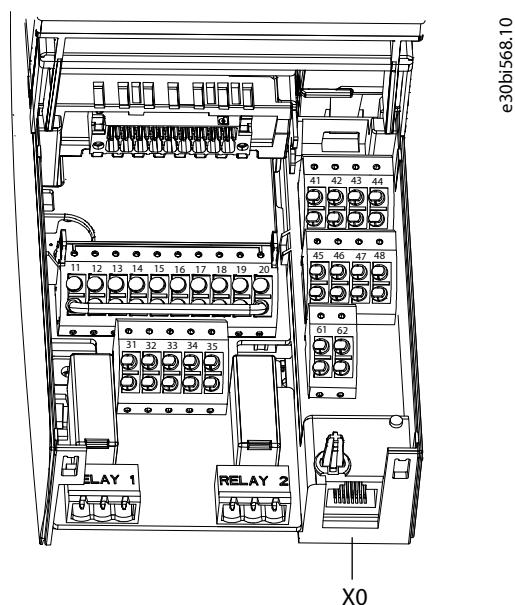

Figure 93: Location of the X0 Port on the Control Board

In drives with the Ethernet-based control board (B5E, A5E), communication interfaces X1 and X2 are on the top of the frequency converter as shown in [Figure 94](#). Drives with the RS-485-based control board (B5S, A5S) have the communication interface X4, located on the top of the frequency converter as shown in [Figure 95](#).

Industrial-grade RJ45 connectors are recommended for optimal connection.

A combined shield/fixing plate, the Fieldbus EMC plate, is available as an accessory to strengthen the mechanical fixation of the cables. For RS-485 connections, it is recommended for proper shield connection. For ordering details, see [12.5 Ordering Self-service Parts](#).

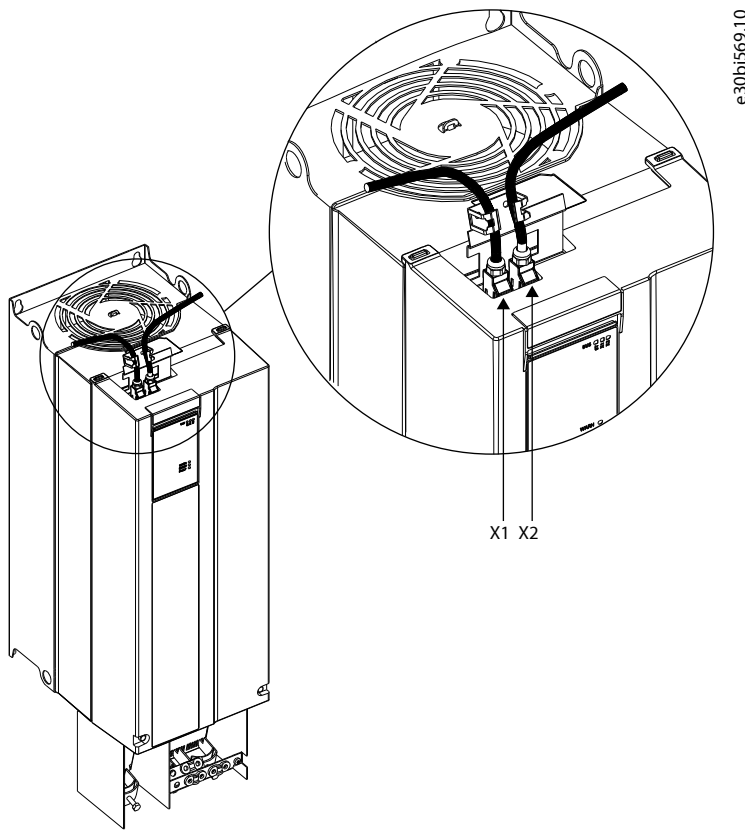

Figure 94: Location of the Communication Interface X1/X2 in FA02-FA12 Frames (with the Optional EMC Plate)

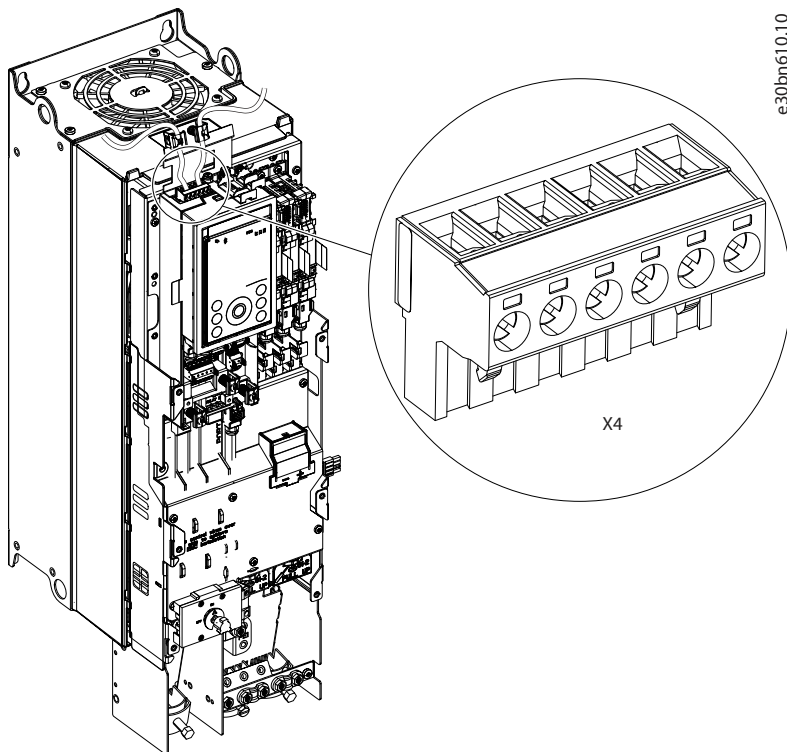

Figure 95: Location of the Communication Interface X4 in FA02-FA12 Frames (with the Optional EMC Plate)

11.7.6.3 Communication Port Locations in FK03, FK05, FB03, and FB05 Frames

In drives with the RS-485-based control board (B5S, A5S) the communication interface X4 is located inside the frequency converter, above the control unit as shown in [Figure 96](#).

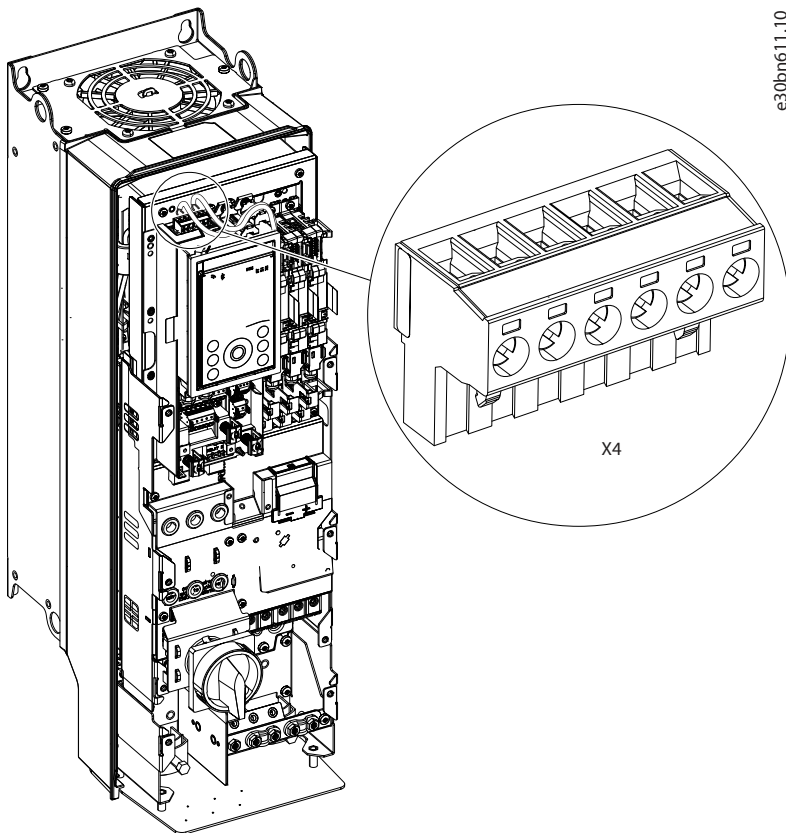

Figure 96: Location of the Communication Interface X4 in FK03, FK05–FK12, FB03, and FB05–FB12 Frames

11.7.6.4 Communication Port Locations in FB06–FB12/FK06–FK12 Frames

Port X0 is on the control board, and communication ports X1 and X2 are located inside the frequency converter.

The position of the ports and the recommended wiring path are shown in [Figure 97](#) and [Figure 98](#).

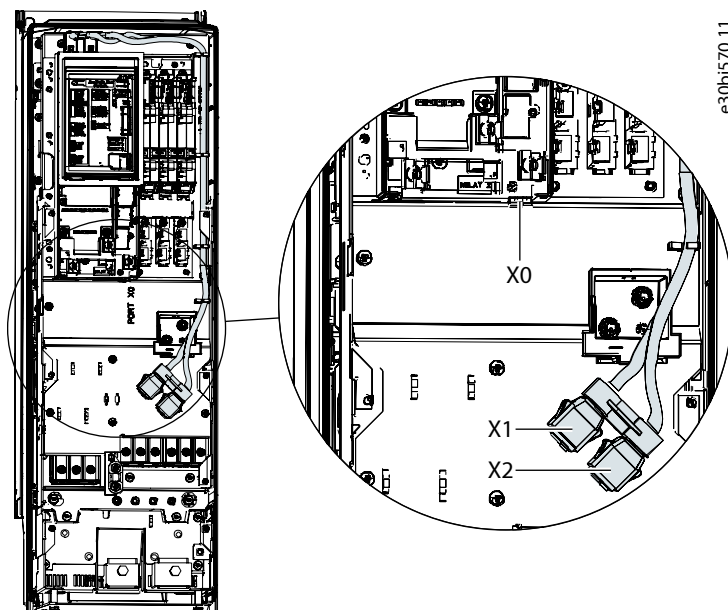

Figure 97: Communication Port X0, X1, and X2 Locations in FK06–FK08/FB06–FB08 Frames

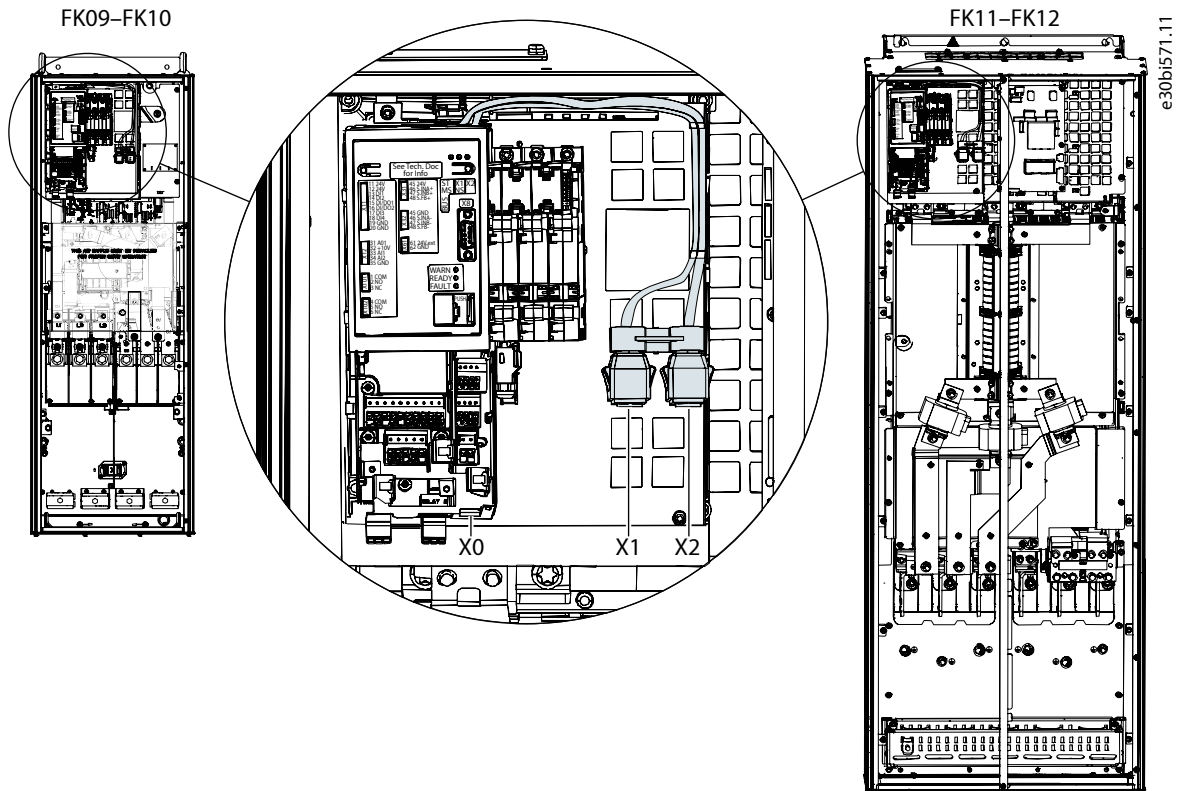

Figure 98: Communication Port X0, X1, and X2 Locations in FK09–FK12/FB09–FB12 Frames

11.7.7 Control Panel Connection (X8)

The control panel is typically mounted on the drive.

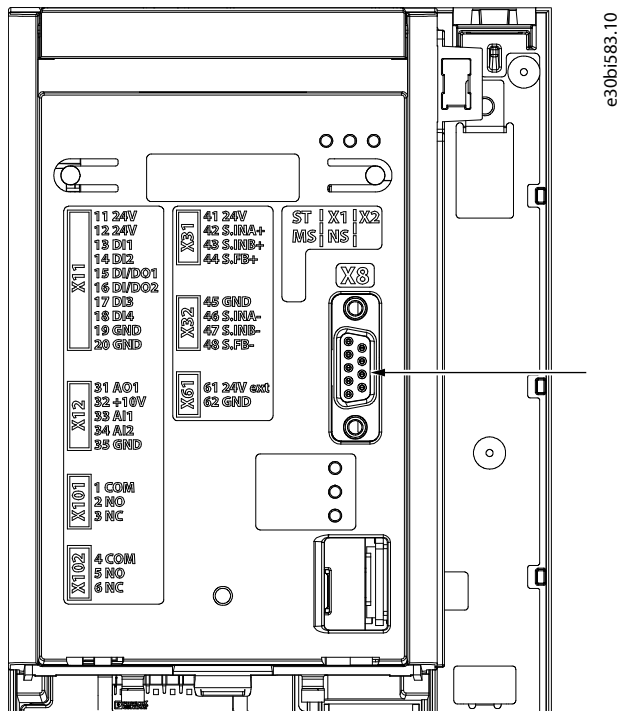

Figure 99: Location of the X8 Connector

It is also possible to mount the control panel externally with a control panel mounting kit. See [5.6 Control Panels](#) and the *iC7 Series Control Panels Mounting Kits Installation Guide* for more information on external mounting of control panels.

11.7.8 Functional Extension Options

Drives with the standard control board (B5S, B5E) can be fitted with 1 functional extension option, which is always installed in slot A. Drives with the advanced control board (A5S, A5E) can be fitted with 1–4 extra functional extension options, depending on the frame, whereas drives with the standard control board only have 1 functional extension option slot. See [7.3.2 Option Slots](#) for more information.

As the connections to some option positions are established via other options, the following dependencies must be observed when designing the system:

- Option in slot B requires an option in slot A.
- Option in slot D requires an option in slot C.
- Option in slot E requires options in both slot C and slot D.

The position of the different slots and the recommendations for installing control cables for extra functional extension options fitted in the frequency converter are shown in [7.3.2 Option Slots](#).

For frames FA02b–FA05b with the advanced control board (A5S, A5E), with options placed in both slot A and B, an extra EMC plate is needed to support the connected control cables.

When installing control cables, wires are connected to the connectors of the selected options, and the cable is fixed (shield connected) in the clamp connection.

For details on the control wiring for options, refer to *iC7 Series Functional Extension Options Operating Guide*.

11.7.9 Control Connectors

For frames Fx06–Fx12, the control connectors are located as shown in [Figure 100](#). The drive has fastener joining points to secure the position of the wires.

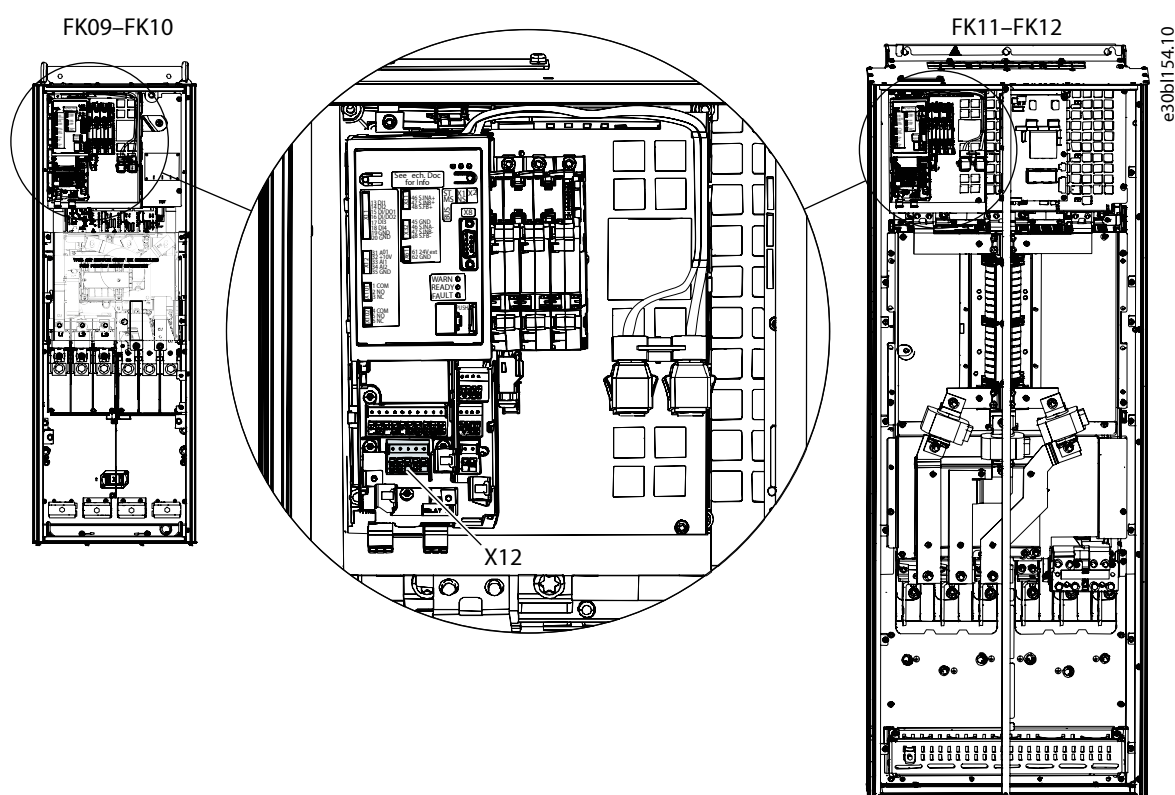

Figure 100: Control Connections in Frames FK06–FK12

11.7.10 Control Wire Sizes and Stripping Lengths

Connections are made by pushing solid wire into the connector. If flexible (multicore) wire is used, ferrules are recommended. When flexible wire is used without ferrules, the connector is pushed with a small screwdriver as shown in [Figure 101](#). The maximum size of the screwdriver is 3 mm (2.5 mm for connectors X31 and X32).

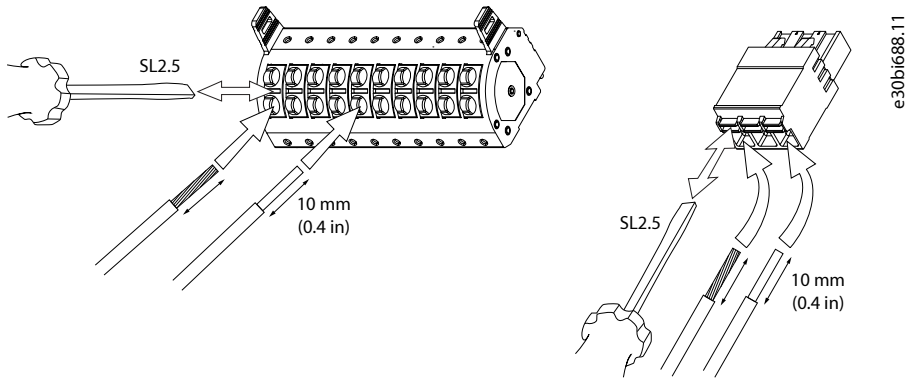

Figure 101: Inserting Wires into the Connector

Table 85: Cable Sizing for Connector X4

Function	Cross-section [mm ² (AWG)]	Stripping length [mm (in)]
Flexible/rigid wire without cable end sleeves	0.2–1.5 mm ² (24–16 AWG)	10 (0.4)
Flexible wire without cable end sleeves	0.2–1.5 mm ² (24–16 AWG)	10 (0.4)

Table 86: Cable Sizing for Connectors X31, X32

Wire type	Cross-section [mm ² (AWG)]	Stripping length [mm (in)]
Solid	0.2–1.5 (24–16)	10 (0.4)
Flexible	0.2–1.5 (24–16)	10 (0.4)
Flexible with ferrule w/o plastic sleeve	0.5–1.5 (20–16)	10 (0.4)
Flexible with ferrule w plastic sleeve	0.5 (24)	10 (0.4)

Table 87: Cable Sizing for Connectors X11, X12, X61

Wire type	Cross-section [mm ² (AWG)]	Stripping length [mm (in)]
Solid	0.2–2.5 (24–14)	10 (0.4)
Flexible	0.2–2.5 (24–14)	10 (0.4)
Flexible with ferrule without plastic sleeve	0.5–2.5 (20–14)	10 (0.4)
Flexible without ferrule with plastic sleeve	0.5–1 (20–17)	10 (0.4)

Table 88: Cable Sizing for Connectors X101, X102

Wire type	Cross-section [mm ² (AWG)]	Stripping length [mm (in)]
Solid	0.2–2.5 (24–14)	10 (0.4)
Flexible	0.2–2.5 (24–14)	10 (0.4)
Flexible with ferrule without plastic sleeve	0.25–2.5 (24–14)	10 (0.4)
Flexible without ferrule with plastic sleeve	0.25–2.5 (24–14)	10 (0.4)

11.7.11 Cable Shield Connection

The cable shield must be completely in contact with the EMC clamp on the EMC plate. Cable isolation must be removed and the cable shield exposed for the entire surface. Avoid pigtails.

For frames FA02b–FA05b, 2 EMC plates are used.

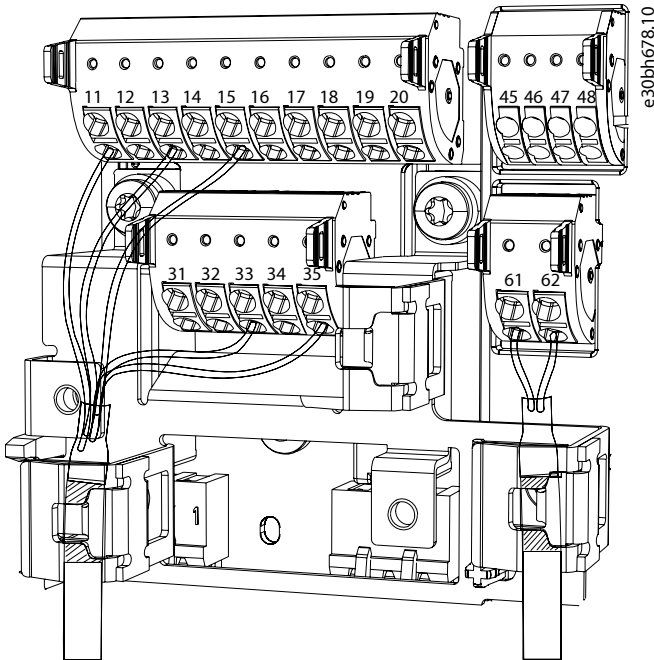

Figure 102: Correct Connection of the Cable Shield

11.8 STO Installation Considerations

Due to the galvanic isolation of the safe inputs, various connections and different polarities are possible in the wiring.

For example, connect a safety actuator to safe input terminals, and set the voltage references as shown in [Figure 103](#) and [Figure 104](#). Setups with the same voltage level on both channels (+24 V) are supported, but also setups with different voltage levels (+24 V and GND).

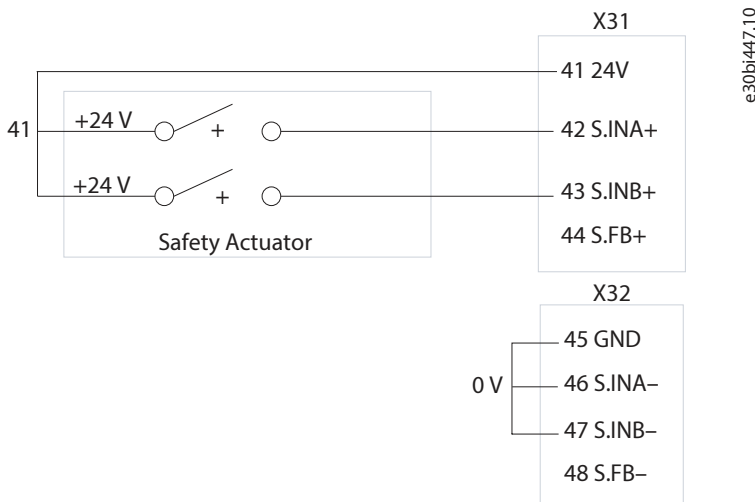

Figure 103: STO Connection Example for Using the Same Polarities (Channel A and Channel B = 24 V)

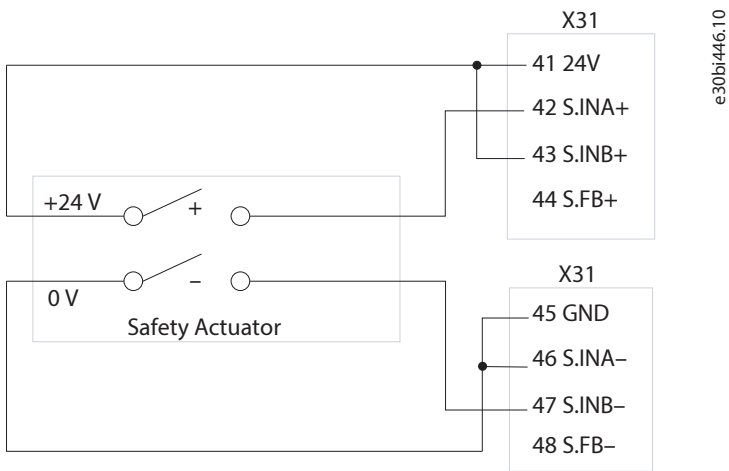

Figure 104: STO Connection Example for Using Different Polarities

For more information on functional safety, refer to *iC7-Aqua and iC7-HVACR Functional Safety Operating Guide*.

12 How to Order

12.1 Selecting the Frequency Converter

Prerequisites:

When selecting a frequency converter, always consider the load conditions of the application first. Selecting the optimum rating requires knowledge about the load profile of the system, for example, the motor current and power, application load characteristics, and operational conditions. For more information about load profiles, see [5.8.1 Load Profile Overview](#).

When selecting a frequency converter, follow these steps to ensure that the drive fulfills the installation and application requirements.

1. Select a power unit and power hardware that match the installation and application requirements.
2. Select control options, functional extensions, communication interfaces, and control panels.

- !** IMPORTANT: The functional extension option selection determines the control board option. For example:
- o If +CBXX in slot B is selected for frame FA02–FA05, frame FA02a–FA05a with the standard control board (B5S, B5E) is shipped. If any other selection is made, the deeper frame variant FA02b–FA05b with the advanced control board (A5S, A5E) is shipped.
 - o If +CCXX in slot C is selected for frame FA06–FA12/FK03–FK12/FB03–FB12, the drive is shipped with the standard control board (B5S, B5E). If any other selection is made, the drive is shipped with the advanced control board (A5S, A5E).

3. Select application software and additional features and/or functionality, if needed.

It is also possible to select filters, accessories, and Danfoss DrivePro® services. For more information, see the ordering site at <https://www.danfoss.com>.

12.2 Model Code

12.2.1 Overview

The configuration of the drive is reflected in the model code. The model code can be used to identify the specific drive configuration and its built-in features.

A model code may look like the following example:

iC7-30FA3N04-43A0E20F1+ALDC+BAMR+BDBA+BEG1+BF20+CAC0+DAAQ

The model code in the example contains the following elements:

Table 89: Example of a Final Model Code

Model code	Function
iC7-30	Product group: iC7-30
FA	Product category: Freq. converter, air-cooled
3N	Product type: 3~ (3 phase power supply)
04	Mains voltage: 380–480 V AC
43A0	Current rating: 43 A
E20	Protection rating: IP20/UL Open Type
F1	EMC category: C1 & C2 category (built-in EMC filter)
+ALDC	DC terminals

Table 89: Example of a Final Model Code - (continued)

Model code	Function
+BAMR	Modbus RTU OC7MR
+BDDBA	Standard I/O: 4xDI, 2xDI/O, 2xAI, 1xAO, 2xRO
+BEG1	Safe Torque Off, Internal diagnostics, not upgradable
+BF20	Control Panel 2.8 OPX20
+CAC0	General Purpose I/O OC7C0 in slot A
+DAAQ	iC7-Aqua

The model code is made up of a mandatory section that describes the basic power hardware (22 characters), and a section that indicates other feature categories (identified as a "Plus code"). Selections in the mandatory part of the model code have fixed positions.

Table 90: Mandatory Elements in the Model Code

Position	Example	Function
1–6	iC7-30	Product group
7–8	FA	Product category
9–10	3N	Product type
11–12	04	Mains voltage
14–17	43A0	Current rating
18–20	E20	Protection rating
21–22	F1	EMC category

Further selections are indicated as fixed character strings with a plus sign (+) as the separator between each feature-specific string. The first 2 characters after the plus sign indicate the feature group, and the remaining characters indicate the selection. When configured, the codes are listed in alphabetical order. A standard selection is defined for the products, which is indicated in this guide in **bold** text, and is not shown in the model code. Only if another selection is made, it is shown in the model code.

The feature category groups are introduced in [Table 91](#).

Table 91: Plus Code Groups in the Model Code

Plus code group	Description
+Axxx	Optional power hardware features
+Bxxx	Control hardware
+Cxxx	Control options
+Dxxx	Application software and additional functionality
+Exxx	Customized settings (for reference only)

For more information about the general dependencies in model code plus code groups, see the dedicated sections for each plus code group. In the sections describing each of the plus code groups, the following symbols are used to indicate availability:

- **X** indicates a standard selection.
- **O** indicates an optional selection.
- A dash (–) indicates that the selection is not available.

The dependencies are not described in full detail, but the configurator at www.danfoss.com supports the correct selections for frequency converters.

12.2.2 Power Hardware

When ordering a drive, a selection must be made for each of the mandatory elements. The available selections are shown for each frame in [Table 92](#), [Table 93](#), [Table 94](#), and [Table 95](#).

6-pulse drives

Table 92: Mandatory Power Hardware Elements for IP20/UL Open Type Drives (FA02–FA12)

Element	Code	Description	FA02–FA05	FA06–FA08	FA09–FA12
Product group	iC7-30	iC7-30	X	X	X
Product category	FA	Frequency converter, air-cooled	X	X	X
Product type	3N	3~ (3 phase)	X	X	X
Mains voltage ⁽¹⁾	04	380–480 V AC	X	X	X
Current rating ⁽¹⁾	01A3–1260	The drive rating in amperes.	See 8.2.2 Ratings for Frequency Converters with 380–480 V Supply Voltage .		
Protection rating	E20	IP20/UL Open Type	X	X	X
EMC category ⁽²⁾	F1	C1 and C2 category	X	X	–
	F2	C2 category	X	X	X
	F3	C3 category	X	X	X

1) The mains voltage and current rating codes form the product code that is used to identify a frame, for example, in the product label and in Specifications in this guide.

2) For more information on the compliance level and recommended cable lengths, see [8.10.1 EMC Compliance Levels](#).

Table 93: Mandatory Power Hardware Elements for IP21/UL Type 1 Drives (FK03, FK05–FK12)

Element	Code	Description	FK03, FK05–FK08	FK09–FK12
Product group	iC7-30	iC7-30	X	X
Product category	FA	Frequency converter, air-cooled	X	X
Product type	3N	3~ (3 phase)	X	X
Mains voltage ⁽¹⁾	04	380–480 V AC	X	X
Current rating ⁽¹⁾	01A3–1260	The drive rating in amperes.	See 8.2.2 Ratings for Frequency Converters with 380–480 V Supply Voltage .	
Protection rating	E21	IP21/UL Type 1	X	X
EMC category ⁽²⁾	F1	C1 and C2 category	X	–
	F2	C2 category	X	X
	F3	C3 category	X	X

1) The mains voltage and current rating codes form the product code that is used to identify a frame, for example, in the product label and in Specifications in this guide.

2) For more information on the compliance level and recommended cable lengths, see [8.10.1 EMC Compliance Levels](#).

Table 94: Mandatory Power Hardware Elements for IP54/IP55/UL Type 12 Drives (FB03, FB05–FB12)

Element	Code	Description	FB03, FB05–FB08	FB09–FB12
Product group	iC7-30	iC7-30	X	X
Product category	FA	Frequency converter, air-cooled	X	X
Product type	3N	3~ (3 phase)	X	X
Mains voltage ⁽¹⁾	04	380–480 V AC	X	X
Current rating ⁽¹⁾	01A3–1260	The drive rating in amperes.	See 8.2.2 Ratings for Frequency Converters with 380–480 V Supply Voltage .	
Protection rating	E54	IP54/UL Type 12	X	X
EMC category ⁽²⁾	F1	C1 and C2 category	X	–
	F2	C2 category	X	X
	F3	C3 category	X	X

1) The mains voltage and current rating codes form the product code that is used to identify a frame, for example, in the product label and in Specifications in this guide.

2) For more information on the compliance level and recommended cable lengths, see [8.10.1 EMC Compliance Levels](#).

Ultra-low harmonic drives

Table 95: Mandatory Power Hardware Elements for Ultra Low-harmonic Drives (FK07, FB07, FA10b, FK10b, FB10b)

Element	Code	Description	FA10b	FK07, FK10b	FB07, FB10b
Product group	iC7-30	iC7-30	X	X	X
Product category	FA	Frequency converter, air-cooled	X	X	X
Product type	3H	3~ (3 phase), low-harmonic drive	X	X	X
Mains voltage ⁽¹⁾	04	380–480 V AC	X	X	X
Current rating ⁽¹⁾	43A0-302A	The drive rating in amperes.	See 8.2.2 Ratings for Frequency Converters with 380–480 V Supply Voltage .		
Protection Rating	E20	IP20/UL Open Type	X	–	–
	E21	IP21/UL Type 1	–	X	–
	E54	IP54/ UL Type 12	–	–	X ⁽²⁾
	E55	IP55/UL Type 12	–	–	X ⁽³⁾
EMC category ⁽⁴⁾	F2	C2 category	X	X	X

1) The mains voltage and current rating codes form the product code that is used to identify a frame, for example, in the product label and in Specifications in this guide.

2) Applies to FB10b.

3) Applies to FB07.

4) For more information on the compliance level and recommended cable lengths, see [8.10.1 EMC Compliance Levels](#).

12.2.3 Optional Power Hardware (+Axxx)

Additional hardware features can be selected as listed in [Table 96](#), [Table 97](#), [Table 98](#), and [Table 99](#). If a selection is not made when ordering a drive, the standard selection (shown in bold) is applied.

Optional power hardware selections for 6-pulse frequency converters

Table 96: Optional Power Hardware Components (Category +Axxx) for IP20/UL Open Type Drives (FA02–FA12)

Function	Model code	Selection description	FA02–FA05	FA06–FA08	FA09–FA12
Extra environmental protection	+AGXX	None	X	X	–
	+AGCX	Coated boards	O	O	X
Mains input device	+AJXX	None	X	X	X
	+AJFX	AC fuses	–	–	O
DC terminals	+ALXX	None	–	X	X
	+ALDC	Yes	X	O	O ⁽¹⁾
Heat sink access panel	+APXX	None	X	X	X
	+APHS	Yes	–	–	O ⁽²⁾

1) DC terminals are not available for Fx10b, FA11, and FA12 frames.

2) Not applicable for frame FA10b.

Table 97: Optional Power Hardware Components (Category +Axxx) for IP21/UL Type 1 Drives (FK03, FK05–FK12)

Function	Model code	Selection description	FK03–FK05	FK06–FK08	FK09–FK12
Extra environmental protection	+AGXX	None	X	X	–
	+AGCX	Coated boards	O	O	X
Humidity protection device	+AHXX	None	X	X	X
	+AHHS	Space Heater	–	–	O
Integrated common-mode filter	+AIXX	None	X	X	X
	+AIC1	Yes	–	–	X ⁽¹⁾
Mains input device	+AJXX	None	X	X	–
	+AJFX	AC fuses	O	O	X
	+AJXD	Mains switch	O	O ⁽²⁾	–
	+AJFD	AC fuses and mains switch	–	O ⁽²⁾	O ⁽³⁾
DC terminals	+ALXX	None	–	X	X
	+ALDC	Yes	X	O ⁽²⁾	O ⁽⁴⁾
Touch protection	+AMXX	None	X	X	X
	+AMMX	Yes	–	–	O
Heat sink access panel	+APXX	None	X	X	X
	+APHS	Yes	–	–	O

1) Only applies to FK09c and FK10c.

2) DC terminals cannot be combined with Mains input device (Mains switch, or AC fuses and mains switch).

3) Only applicable in frames FK09c, FK10c, FK11, and FK12. Not applicable to 385A drive in FK09c: select 395A variant in frame FK10c instead.

4) DC terminals are only available in FK09c and FK10c frames. DC terminals are not available for FK09a, FK10a, FK11 and FK12 frames.

Table 98: Optional Power Hardware Components (Category +Axxx) for IP54/IP55/UL Type 12 Drives (FB03, FB05–FB12)

Function	Model code	Selection description	FB03–FB05	FB06–FB08	FB09–FB12
Extra environmental protection	+AGXX	None	X	X	–
	+AGCX	Coated boards	O	O	X

Table 98: Optional Power Hardware Components (Category +Axxx) for IP54/IP55/UL Type 12 Drives (FB03, FB05–FB12) - (continued)

Function	Model code	Selection description	FB03–FB05	FB06–FB08	FB09–FB12
Humidity protection device	+AHXX	None	X	X	X
	+AHHS	Space heater	–	–	O
Integrated common-mode filter	+AIXX	None	X	X	X
	+AIC1	Yes	–	–	X ⁽¹⁾
Mains input device	+AJXX	None	X	X	X
	+AJFX	AC fuses	O	O	O
	+AJXD	Mains switch	O	O ⁽²⁾	–
	+AJFD	AC fuses and mains switch	–	O ⁽²⁾	O ⁽³⁾
DC terminals	+ALXX	None	–	X	X
	+ALDC	Yes	X	O ⁽²⁾	O ⁽⁴⁾
Touch protection	+AMXX	None	X	X	X
	+AMMX	Yes	–	–	O
Heat sink access panel	+APXX	None	X	X	X
	+APHS	Yes	–	–	O

1) Only applies to FB09c and FB10c.

2) DC terminals cannot be combined with Mains Input Device (Mains switch, or AC fuses and mains switch).

3) Only applicable in frames FB09c, FB10c, FB11, and FB12. Not applicable to 385A drive in FB09c: select 395A variant in frame FB10c instead.

4) DC terminals are only available in FB09c and FB10c frames. DC terminals are not available for FB09a, FB10a, FB11 and FB12 frames.

Optional power hardware selections for ultra low-harmonic drives

Table 99: Optional Power Hardware Components (Category +Axxx) for Ultra Low-Harmonic Drives

Function	Model code	Selection description	FK07	FB07	FA10b	FK10b	FB10b
Extra environmental protection	+AGXX	None	X	X	–	–	–
	+AGCX	Coated Boards	O	O	X	X	X
Mains input device	+AJXX	None	X	X	–	–	–
	+AJFX	AC fuses	O	O	X	X	X
	+AJXD	Mains switch	O	O	–	–	–
Touch protection	+AMXX	None	X	X	X	X	X
	+AMMX	Yes	–	–	–	O	O

12.2.4 Control Board Features (+Bxxx)

Available selections for control board functionalities are listed in [Table 100](#). If a selection is not made, the standard configuration (shown in bold) is applied. The control board type (code +BAxx) and functional safety type (code +BExx) must always be selected.

Table 100: Control Board Features in the Model Code

Function	Model code	Selection description
Communication interface, X1/X2	+BAMT	Modbus TCP OS7MT
	+BAMR	Modbus RTU OC7MR
	+BAPX	PROFINET RT OS7PR
	+BAEX	EtherCAT OS7EC
	+BAIX	EtherNet/IP OS7IP
Standard I/O	+BDBA	Basic I/O (4 x DI, 2 x combined DI/DO, 2 x AI, 1 x AO, 2 x Relay)
Functional safety	+BEG1	STO with internal diagnostics - Not upgradable
Control panel	+BF00 ⁽¹⁾	Blind Panel OPX00
	+BF20	Control Panel 2.8 OPX20
Interface board	+BIXX ⁽²⁾	None
	+BISR ⁽³⁾	MicroSD card reader and RTC

1) Not available for Fx09–Fx12.

2) Selected when the standard control board B5S or B5E is used.

3) Selected when the advanced control board A5S or A5E is used.

12.2.5 Functional Extension Options (+Cxxx)

For guidance on option slots, see [Table 101](#).

The final code of the selection depends on the slot which the option is installed in. For example, when installing the General Purpose I/O OC7C0 option in slot B, the code is +CBC0.

The selection of options in slot B or slot C affects the selection of the control board variant. For frames FA02–FA05 selecting +CBXX in slot B results in using the standard control board (B5S, B5E) and frame FA02–FA05a. If any other selection is made, the advanced control board (A5S, A5E) and the deeper frame variants FA02b–FA05b are used. For frames FA06–FA12, FK03–FK12, and FB03–FB12, selecting +CCXX in slot C results in using the standard control board (B5S, B5E). If any other selection is made, the advanced control board (A5S, A5E) is used. For more details on the differences in functionality, see [5.5 Control Unit and Interfaces](#).

Table 101: Functional Extension Model Codes

Model code					Function
Slot A	Slot B	Slot C	Slot D	Slot E	
–	+CBXX	+CCXX	–	–	None – Not upgradable ⁽¹⁾
+CAX0	+CBX0	+CCX0	+CDX0	+CEX0	None
+CAC0	+CBC0	+CCC0	+CDC0	+CEC0	General Purpose I/O OC7C0
+CAR0	+CBR0	+CCR0	+CDR0	+CER0	Relay Option OC7R0
+CAT0	+CBT0	+CCT0	+CDT0	+CET0	Temperature Measurement OC7T0

1) In frames FA02a–FA05a, slots C–E are defined as +CCX0, +CDX0, and +CEX0. In all other frames, slot B is defined as +CBXX.

12.2.6 Application Software and Additional Functionality (+Dxxx)

The available selections for application software and additional functionalities are listed in [Table 102](#). If a selection is not made when ordering a drive, the standard selection (shown in bold) is applied.

Table 102: Application Software and Additional Feature Selections in the Model Code

Function	Model code	Selection description
Product series	+DAAQ	iC7-Aqua
High speed enabled	+DI6X	None
	+DI61	Enabled ⁽¹⁾

1) Only with special agreement due to dual-use restrictions.

12.2.7 Customized Settings (+Exxx)

The selections for customized settings are typically based on settings that are not selectable in the standard product offering. They are only shown to indicate possible variants.

Table 103: Customized Settings in the Model Code

Function	Model code	Selection description
Customization file package ID	+EAXXXXXX	Customized settings of the drive indicated by a 6-digit alphanumeric value
Product software ID	+ECXX	Latest released version ⁽¹⁾
Technical documentation	+EGXX	None ⁽²⁾
	+EGIN	Installation guide included
Customer specific label	+EJXX	No
	+EJCL	Yes

1) By default, drives are shipped with latest released software (+ECXX). If shipped with a different version, the code is different and can be read in the model code information of the drive.

2) With special agreement only.

12.3 Ordering Input and Output Filters

When ordering filters, selection is based on the specific variable frequency drive and its application.

Sine-wave filters are selected to align with the output current, supply voltage, and overload rating (LO or HO1) of the drive and application.

For harmonic mitigation, harmonic filters are selected based on the input current rating of the drive. Certain filters, for example, the Advanced Harmonic Filter OF7P2, are designed exclusively for 6-pulse drives. It is possible to connect a single filter to multiple drives, but this configuration has specific input fusing requirements for both the filter and each drive.

For detailed information on filter selection and to place an order, contact Danfoss.

12.4 Ordering Options and Accessories

Table 104: Code Numbers for Ordering Options and Accessories

Category	Part name	Compatibility	Code number
Control panel options and accessories	Blind Panel OPX00	Fx02–Fx08	136B2055
	Control Panel 2.8 OPX20	Fx02–Fx12	136B3128
	Control panel flush mounting kit	Fx02–Fx12	136B2082
	Control panel surface mounting kit	Fx02–Fx12	136B2083
	Control panel cable – 2.5 m	Fx02–Fx12	136B2084
	Control panel cable – 5 m	Fx02–Fx12	136B2085

Table 104: Code Numbers for Ordering Options and Accessories - (continued)

Category	Part name	Compatibility	Code number
	Control panel cable – 10 m	Fx02–Fx12	136B2086
Functional extensions	General Purpose I/O OC7C0	Fx02–Fx12	136B1568
	Relay Option OC7R0	Fx02–Fx12	136B1567
	Temperature Measurement OC7T0	Fx02–Fx12	181B6143
Cooling kits for Rit-tal TS8 and VX25 enclosures	In-bottom/out-top cooling kit, FA09	FA09	176F4038
	In-bottom/out-back cooling kit, FA09	FA09	176F4040
	In-back/out-top cooling kit, FA09	FA09	176F4042
	In-back/out-back cooling kit, FA09	FA09	176F4045
	In-back/out-back cooling kit, FK09a/FB09a	FK09a/FB09a	176F4184
	In-back/out-back cooling kit, FK09c/FB09c	FK09c/FB09c	176F4190
	In-bottom/out-top cooling kit, FA10	FA10	176F4039
	In-bottom/out-back cooling kit, FA10	FA10	176F4041
	In-back/out-top cooling kit, FA10	FA10	176F4043
	In-back/out-back cooling kit, FA10	FA10	176F4046
	In-back/out-back cooling kit, FK10a/FB10a	FK10a/FB10a	176F4185
	In-back/out-back cooling kit, FK10c/FB10c	FK10c/FB10c	176F4191
	In-bottom/out-top cooling kit for FA11 frequency converters – 600 mm cabinet	FA11	176F4047
	In-bottom/out-top cooling kit for FA11 frequency converters – 800 mm cabinet	FA11	176F4192
	In-bottom/out-back cooling kit for FA11 frequency converters – 600 mm cabinet	FA11	176F4059
	In-bottom/out-back cooling kit for FA11 frequency converters – 800 mm cabinet	FA11	176F4193
	In-back/out-top cooling kit for FA11 frequency converters	FA11	176F4061
	In-back/out-back cooling kit for FA11 frequency converters	FA11	176F4057
	In-bottom/out-top cooling kit for FA12 frequency converters	FA12	176F4048
	In-bottom/out-back cooling kit for FA12 frequency converters	FA12	176F4060
In-back/out-top cooling kit for FA12 frequency converters	FA12	176F4062	
In-back/out-back cooling kit for FA12 frequency converters	FA12	176F4058	
Pedestal kits	400 mm Pedestal kit for FK09a/FB09a frequency converters	FK09a/FB09a	176F4034
	200 mm Pedestal kit for FK09c/FB09c frequency converters	FK09c/FB09c	176F4036
	400 mm Pedestal kit for FK10a/FB10a frequency converters	FK10a/FB10a	176F4035
	400 mm Pedestal kit for FK11/FB11 frequency converters	FK11/FB11	176F4044
	400 mm Pedestal kit for FK12/FB12 frequency converters	FK12/FB12	176F4037
Common mode core kits	HF Common mode core kit, FK09a/FB09a	FK09a/FB09a	176F4174
	HF Common mode core kit, FK10a/FB10a	FK10a/FB10a	176F4175

Table 104: Code Numbers for Ordering Options and Accessories - (continued)

Category	Part name	Compatibility	Code number
	HF Common mode core kit, FK11/FB11	FK11/FB11	176F4176
	HF Common mode core kit for FK12/FB12	FK12/FB12	176F4177
Touch protection kits	Touch protection kit, FK09a/FB09a	FK09a/FB09a	176F4164
	Touch protection kit, FK09c/FB09c	FK09c/FB09c	176F4163
	Touch protection kit, FK10a/FB10a	FK10a/FB10a	176F4161
	Touch protection kit, FK10c/FB10c	FK10c/FB10c	176F4162
	Touch protection kit, FK11/FB11	FK11/FB11	176F4132
	Touch protection kit, FK12/FB12	FK12/FB12	176F4135
Ground bar kits	Ground bar kit, FK09a/FB09a ⁽¹⁾	FK09a/FB09a	176F4170
	Ground bar kit, FK09c/FB09c	FK09c/FB09c	176F4186
	Ground bar kit, FK10a/FB10a ⁽¹⁾	FK10a/FB10a	176F4171
	Ground bar kit, FK10c/FB10c	FK10c/FB10c	176F4187
	Ground bar kit for FK11/FB11, FK12/FB12 ⁽²⁾	FK11/FB11, FK12/FB12	176F4188
Multi-wire kits	Multi-wire kit, Fx09–Fx10	Fx09–Fx10	176F4189

1) If a common-mode filter kit is used, it is not possible to use a ground bar kit.

2) If a common-mode filter kit is used, components of the ground bar kit cannot be installed for the output side.

12.5 Ordering Self-service Parts

Parts that may need to be replaced during the lifetime of the drive are available as spare parts. Available self-service parts are listed in [Table 105](#). For other parts, contact Danfoss. A list of available spare parts for products can also be found at <https://www.danfoss.com>.

Table 105: List of Self-service Parts

Part type	Part name	Used in	Code number
Control covers	Terminal cover iC7 FA02a	FA02a	136B2056
	Terminal cover iC7 FA02b	FA02b	136B2059
	Terminal cover iC7 FA04a–FA05a	FA04a, FA05a	136B2058
	Terminal cover iC7 FA04b–FA05b	FA04b, FA05b	136B2061
	Side cover FA04a	FA04a	136B2067
	Side cover FA04b	FA04b	136B2070
	Side cover FA05a	FA05a	136B2068
	Side cover FA05b	FA05b	136B2071
Control panel cradles	Control panel cradle FA02a	FA02a	136B2062
	Control panel cradle FA02b	FA02b	136B2064
	Control panel cradle FA03a–FA05a	FA03a–FA05a	136B2063
	Control panel cradle FA03b–FA05b	FA03b–FA05b	136B2065
	Control panel cradle Fx06–Fx08	Fx06–Fx08	136B2943

Table 105: List of Self-service Parts - (continued)

Part type	Part name	Used in	Code number
Control connectors	Control board connectors (X31, X32, X61)	Control board	136B1927
	I/O connectors (X11, X12, X101, X102)	Basic I/O board	136B1924
	I/O connectors (X101, X102, X103)	Relay Option OC7R0	136B3162
	I/O connector (X14)	General Purpose I/O OC7C0	136B3160
	I/O connector (X54)	Temperature Measurement OC7T0	181B6557
	Option connector	Options	136B1570
Power connectors	Power connectors FA02-FA03	FA02	136B2072
	Power connectors FA04	FA04	136B2073
	Power connectors FA05	FA05	136B2074
Input plates	Input plate FK06	FK06	136B2939
	Input plate FK07	FK07	136B2940
	Input plate FK08	FK08	136B2941
EMC plates	Power connectors and EMC plate FA02-FA03	FA02	136B1921
	Power connectors and EMC plate FA04	FA04	136B1922
	Power connectors and EMC plate FA05	FA05	136B1923
	EMC plate FA06	FA06	136B3507
	EMC plate FA07	FA07	136B3508
	EMC plate FA08	FA08	136B3509
Control EMC plates	EMC plate Slot A	Fx02–Fx12	136B2076
	EMC plate Slot B	FA02–FA05	136B1925
	EMC plate Slot C-E	Fx03–Fx12	136B1928
	Fieldbus EMC plate FA02-FA08	FA02–FA08	136B1926
	Fieldbus EMC plate FA09-FA12	FA09–FA12	176F3529
Fans	Main fan FA02	FA02	136B2077
	Main fan FA04	FA04	136B2079
	Main fan FA05	FA05	136B2080
Door filter	Door filter for FK09-FK12/FB09-FB12	FK09–FK12/FB09–FB12	176F3353



Danfoss A/S
Ulsnaes 1
DK-6300 Graasten
drives.danfoss.com

Any information, including, but not limited to information on selection of product, its application or use, product design, weight, dimensions, capacity or any other technical data in product manuals, catalog descriptions, advertisements, etc. and whether made available in writing, orally, electronically, online or via download, shall be considered informative, and is only binding if and to the extent, explicit reference is made in a quotation or order confirmation. Danfoss cannot accept any responsibility for possible errors in catalogs, brochures, videos and other material. Danfoss reserves the right to alter its products without notice. This also applies to products ordered but not delivered provided that such alterations can be made without changes to form, fit or function of the product. All trademarks in this material are property of Danfoss A/S or Danfoss group companies. Danfoss and the Danfoss logo are trademarks of Danfoss A/S. All rights reserved.

M00453
AJ491231549263en-000301
Danfoss A/S © 2026.03

