



Remote Control MP20V Receiver



Revision history

Table of revisions

Date	Changed	Rev
April 2026	Updated Danfoss information	0401
February 2025	Updated installation directions and safety information	0301
March 2022	Updated safety instructions and technical description	0201
January 2019	Rebranded to Danfoss Power Solutions	0101

Safety instructions

FCC rules..... 4
General safety..... 4
Safety warnings..... 5
Data Encryption..... 6

Technical description

Dimensions..... 7
Hardware description..... 8
MP20A/MP20V detailed description..... 8

Installation

Receiver installation..... 10
Input and output configuration..... 11
 Digital outputs..... 11
 Analog outputs..... 13
 Pinout..... 14

Troubleshooting

400 - 900MHz Receiver icon troubleshooting..... 15
2.4GHz Receiver Icon Troubleshooting..... 15

Safety instructions

FCC rules

This equipment has been tested and found to comply with the limits for a Class A digital device, pursuant to Part 15 of the FCC Rules.

Note

Changes or modifications not expressly approved by the manufacturer can void the user's authority to operate the equipment.

Note

To comply with FCC RF exposure compliance requirements, this device and its antenna must not be collocated with, or operating in conjunction with, any other antenna or transmitter, may not cause harmful interference, and must accept any interference received, including interference that may cause undesired operation.

The limits are designed to provide reasonable protection against harmful interference when the equipment is operated in a commercial environment. This equipment generates, uses, and can radiate radio frequency energy, and if not installed and used in accordance with the instruction manual, may cause harmful interference to radio communications.

Operation of this equipment in a residential area is likely to cause harmful interference in which case the user will be required to correct the interference at his own expense.

Warning

Le présent appareil est conforme aux CNR d'Industrie Canada applicables aux appareils radio exempts de licence. L'exploitation est autorisée aux deux conditions suivantes:

1. l'appareil ne doit pas produire de brouillage, et
2. l'utilisateur de l'appareil doit accepter tout brouillage radioélectrique subi, même si le brouillage est susceptible d'en compromettre le fonctionnement.

MP20V General Safety

The following safety instructions must be read carefully to install and use the product properly, and to keep it in perfect working condition, and to reduce the risk of miss use.

- **Danfoss recommends the use of ESD PPEs (electrostatic discharge personal protection equipment).**
- Strictly adhere to the installation instructions contained in this document.
- Make sure that professional and competent personnel carry out the installation.
- Ensure that all on site and prevailing safety regulations are fully respected.
- The Electrical Installation where it may be connected, The receiver may be connected through an automatic magneto thermic switch (with omnipolar cut capacitance: F+N) and differential with characteristics according to the Low Voltage Recommendations.
- Make sure that this document is permanently available to the operator and maintenance personnel.
- Keep the transmitter out of reach of non-authorized personnel.
- Remove the transmitter key when the set is not in use.
- Check each working day the STOP button and other safety features. When in doubt, press the STOP button.
- Whenever several sets have been installed, make sure the transmitter is the right one. Identify the machine controlled on the label for this purpose on the transmitter or by using the display (in case it does have one).
- Service the equipment periodically.
- Avoid High Pressure water Spraying to Receivers while cleaning the machine
- When carrying out repairs, use spare parts supplied by Danfoss only.

Warning

Potential damage to the operator or the product. Do not use this product on machines in potentially explosive atmospheres unless the model is ATEX/RATEX certified to work in such conditions.

MP20V Safety Warnings

Potential damage to operator and product.

Follow the guidelines below to reduce risk of injury to the operator and the product.

- Use the device with the manufacturer's battery and battery charger (if applicable).
- Only allow qualified personnel to operate the equipment.
- Always set the STOP button in the off position when not in use.
- Always press STOP before plugging in tether cable (if applicable).
- Remove the Tether connection on the transmitter First (if applicable).
- Do not operate product when visibility is limited.
- Make sure product is compatible with the machine.
- Avoid knocking or dropping the product.
- Do not use the product if a failure is detected.

Note

Changes or modifications not approved by Danfoss can void the user's authority to operate this product.

Quick reference precautions

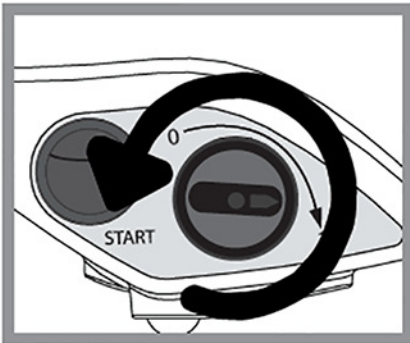

Remove the transmission key only when the set is not in use or to deny the access

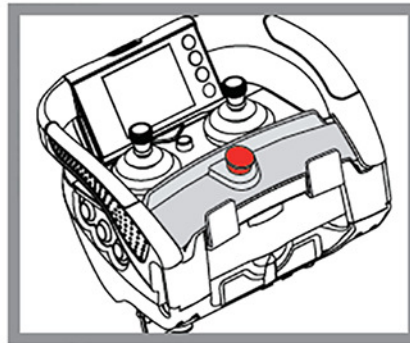

When in doubt, press the STOP button

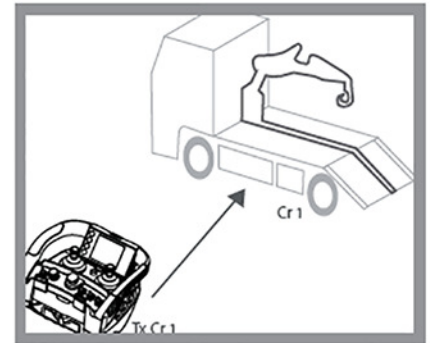

Make sure the transmitter works with the machine to be handled

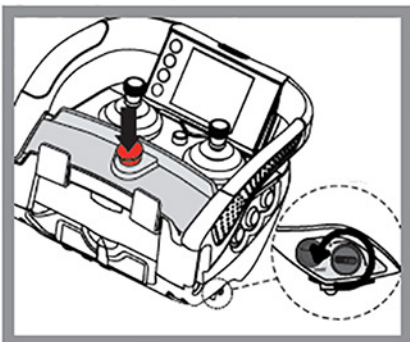

After use set the contact key and the STOP button



Do not use the set when visibility is limited

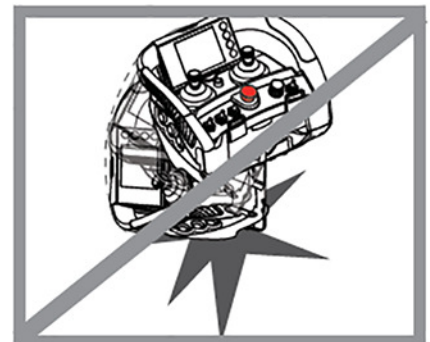

Avoid knocking or dropping the set

Data Encryption

In alignment with **Commission Delegated Regulation (EU) 2022/30**, supplementing the **Radio Equipment Directive (RED) 2014/53/EU**, we are introducing **encryption for radio communication** in TM80 2.4 GHz platform. This measure is designed to:

- Protect the integrity and confidentiality of transmitted data
- Prevent unauthorized access and misuse of network resources

Technical description

MP20 dimensions

Dimensions in mm

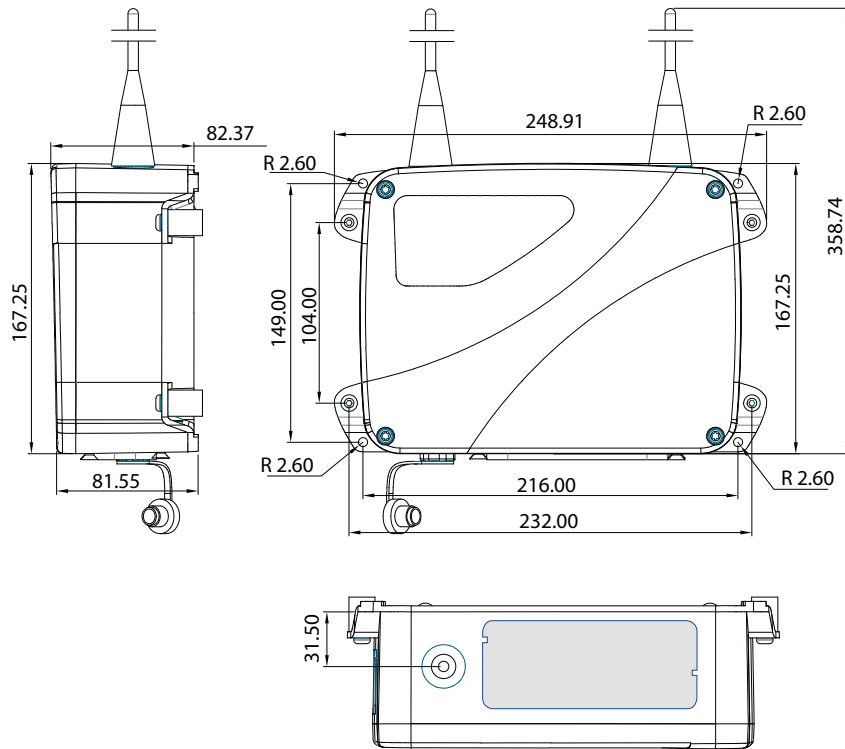

MP20V hardware description

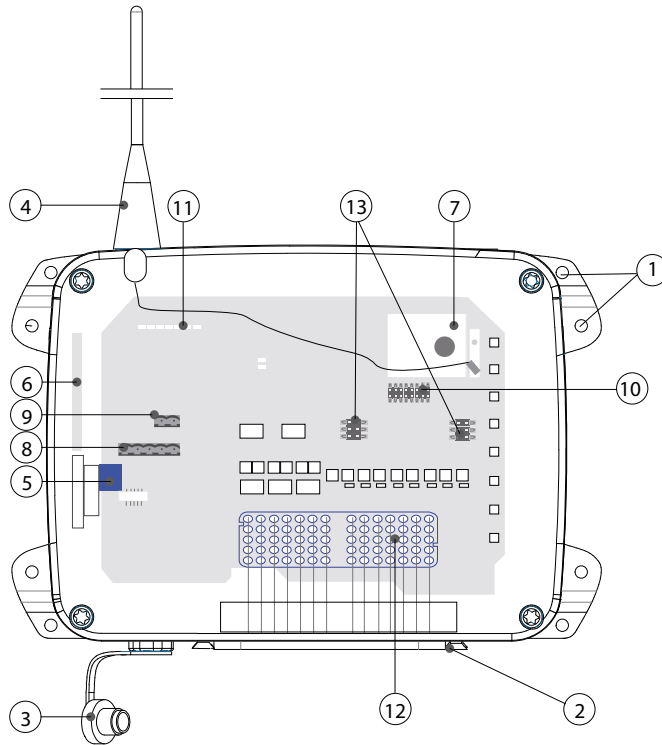

1. Fixing slots (fixed assembly or anti-vibration)
2. DEUTSCH connector
3. Tether connection
4. External antenna A60 (433), A70 (870) or 2.4GHz
5. External EEPROM
6. LCD connection
7. RF Module
8. CAN connection
9. CAN power supply
10. BUS termination CAN
11. Signaling intern LEDs
12. DEUTSCH connector pinout
13. Switches to control voltage options

MP20A/MP20V detailed description

Technical data

Specification	MP20A	MP20V
Stop Function (400-900 MHz)	Cat. 3-PLd	
Stop Function (2.4GHz)	Cat. 3-PLe	
Ingress protection Rating	IP65/NEMA4	

Technical data (continued)

Specification	MP20A	MP20V
Frequency band - ERP	433.050 to 434.040 MHz; ERP<1mW	
	434.040 to 434.790 MHz; ERP<10mW	
	869.700 to 870.000 MHz; ERP<5mW	
	902.000 to 928.000 MHz; ERP<1mW	
	2405MHz to 2475MHz 20dBm/100mW	
Range Line of sight (guaranteed)	100m	
AC power supply	N/A	
DC power supply	8-35 Vdc (200mA)	
Antenna	External	
Removable EEPROM	External	
Signaling	External	
STOP Outputs (400-900MHZ)	1 (2A)	
STOP Outputs (2.4GHz)	1 (2A)	
Start Output	N/A	
Safety Relay	N/A	
ON/OFF Outputs	12 (2A per Output)	
Proportional Outputs	8 PWM (2.5A per Output)	8 Voltage (20mA per Output)
CAN Bus Protocols	CANopen	
ON/OFF Inputs	4	
Proportional Inputs	Optional	
Maximum Total Output Current	7.5A	
Working Temperature Range	-20°C to +70°C (-4° F to +158° F)	
Storage Temperature Range (24h)	-25°C to 75°C (-13°F to 167°F)	
Storage Temperature Range (long periods)	-25°C to 55°C (-13°F to 131°F)	
Relative Humidity	max. 95% without condensation	
Weight	1230 g	
Dimensions LxWxH mm	245 x 160 x 80mm	
Tether Connector	Yes (M12 Connector)	
Associated Transmitters (400-900 MHz)	Ikargo2, T70/2, T70/2 HALL, IK2, IK3, IK4	
Associated Transmitters (2.4 GHz)	Ikore, IkoreB, Icompact, Ikargo1, Ikargo2, IK1-G, IK2, IK3, IK4	
Additional Outputs		
	8 ON/OFF or 2 (PWM or Voltage) or (20 ON/OFF or 5 Analog Inputs)	

Installation

MP20V receiver installation

The below information describes hazards to be aware of during installation and steps to locate the receiver.

Risk of shock

Completely shut down the machine when installing the receiver.

Check the power supply and shut off the main switch to disconnect the interface cable between the receiver and the machine's electrical box.

1. Find an easily accessible and clear location with a direct vision between the receiver's antenna and the transmitter's working area.



2. Optional: If it is difficult to achieve direct vision between the receiver's antenna and the transmitter's working area, it is recommended to use an extended antenna in a clear location (only for models that allow an antenna).

In areas of high vibration, the use of Shock Absorbers is advised.

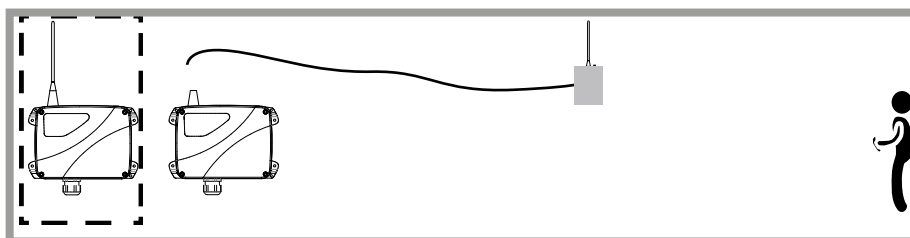

3. Proceed to connect the power supply. Use the connection block diagram provided with the system, where the correspondence between the transmitter maneuvers and the receiver's outputs are detailed.

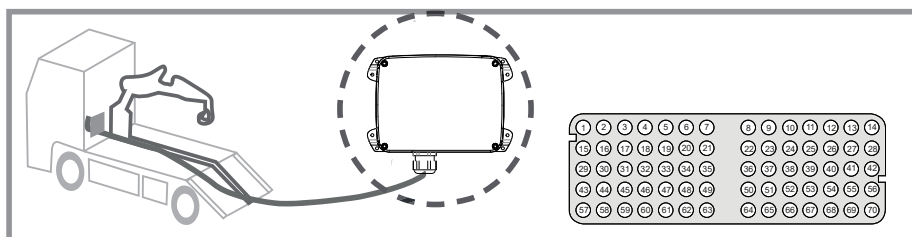

4. Check if the electrical installation and verify if there's an option to connect the neutral or the ground cable. In that case, don't forget to connect the ground cable.

The use of fireproof or flame retardant cables are recommended for the connection.

MP20 input and output configuration

The MP20 includes a 7.5A permeable internal fuse.

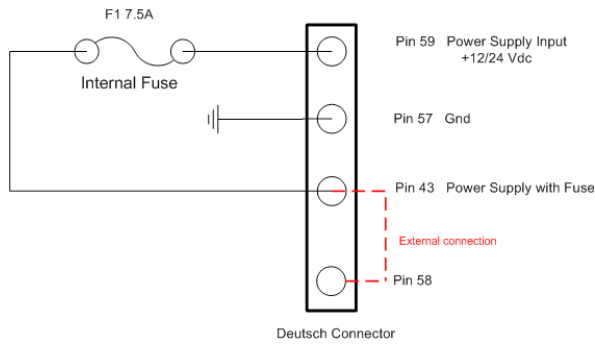

MP20 digital outputs

The digital outputs K1-K4 have a common contact at pin 47 of the connector. This pin is connected to pin 46 (stop) for powering up this group of outputs. Maximum 2A per output. It is recommended to use K1 for by-pass valve.

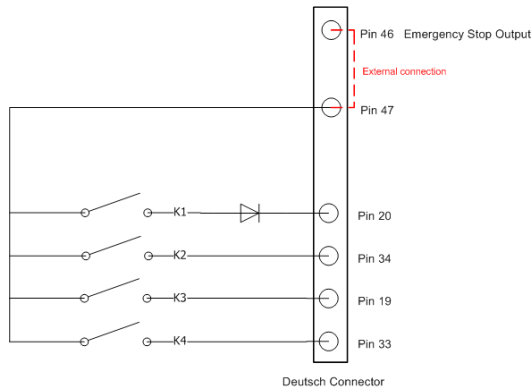

The digital output K5-K12 have a common contact at pin 48 of the connector. This pin is connected to pin 45 (stop) for powering up this group of outputs. Maximum 2A per output.

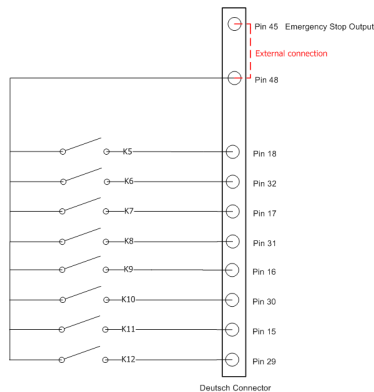

As an alternative, the K5-K12 output group can be connected directly to the external general power supply in order to provide a higher capacity of current.

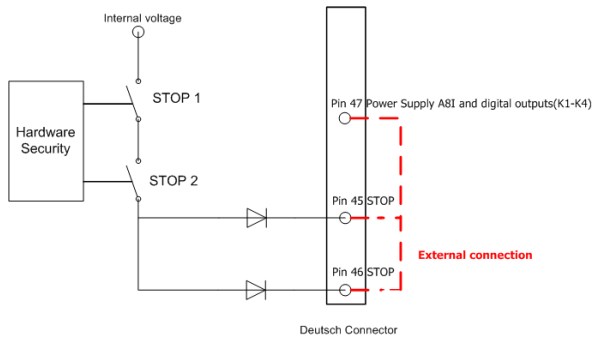
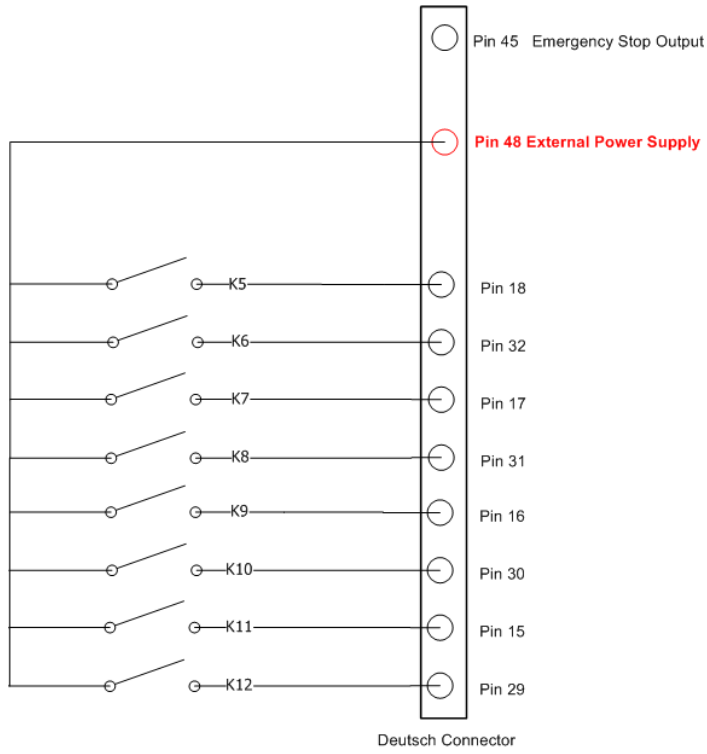

MP20V proportional outputs

The proportional outputs, that are different for MP20A or MP20V, have a common contact at pin 47 of the connector. This pin is connected to pin 46 (stop) for powering up the 1-8 outputs.

Nsa1-Nsa8 have a common contact at pin 47 of the connector. Pin 47 connects with pin 46 (STOP) in order to feed nSA1-nSA8 outputs. Maximum 20mA per output.

The MP20V allows to choose the control voltage in order to set the output power with the selection of 2 switches. Control voltage options: 0-5V, 0-10V, 0-Vcc.

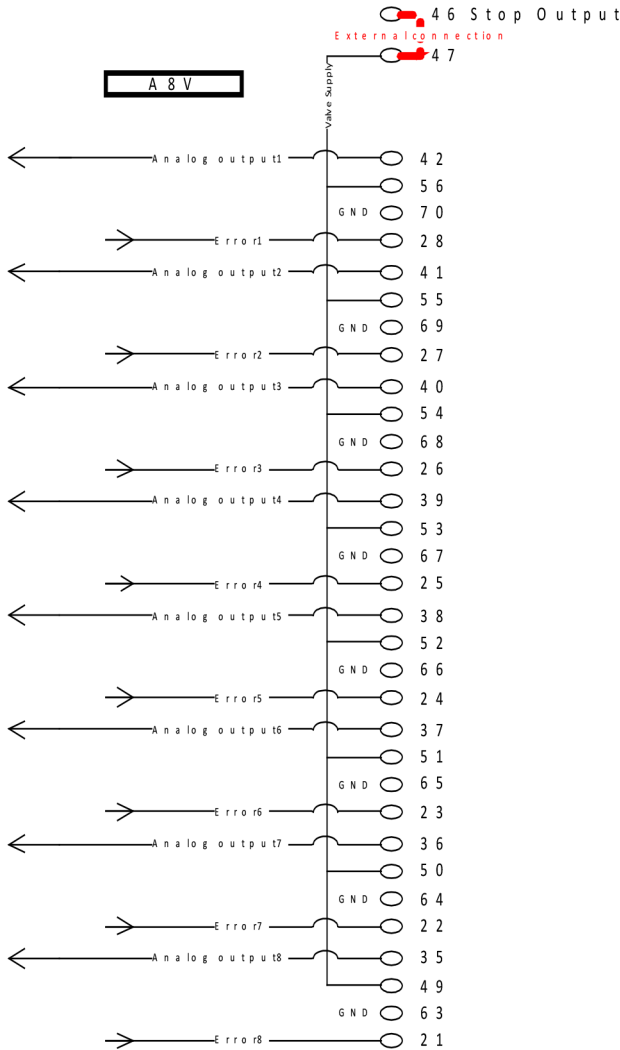

Jumper	Legend	Jumper	Description	Jumper
1	12/24	ON	Battery Voltage	1
2	0-10	ON	Maximum 10Vcc	2
3	0-5	ON	Maximum 5Vcc	3
4	Vcc/2	OFF	Rest Voltage Vcc/2	4

Only 2 Jumpers can be placed at the same time, only 1 voltage selection Jumper can be ON, and Vcc/2 to remove the half voltage selection. Default, only Jumper 1 is placed, being Battery level 12 or 24Vcc and Voltage in resting (neutral) position is Vcc/2.

MP20V pinout

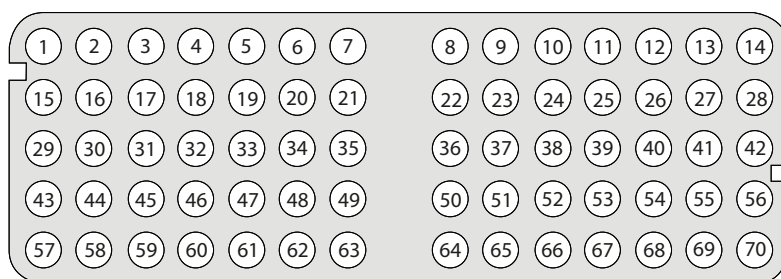

Pin	Description	Pin	Description
1	CAN-H	36	SA-7 (Voltage output 7)
2	CAN-GND	37	SA-6 (Voltage output 6)
3	CAN-L	38	SA-5 (Voltage output 5)
4	-	39	SA-4 (Voltage output 4)
5	-	40	SA-3 (Voltage output 3)
6	-	41	SA-2 (Voltage output 2)
7	IN-4	42	SA-1 (Voltage output 1)
8	-	43	Power Supply with Fuse
9	-	44	Manual
10	-	45	STOP
11	-	46	STOP
12	-	47	A8V; K1-4
13	-	48	K5-K12
14	-	49	Vdc8
15	K11	50	Vdc7
16	K9	51	Vdc6
17	K7	52	Vdc5
18	K5	53	Vdc4
19	K3	54	Vdc3
20	K1	55	Vdc2
21	Err8	56	Vdc1
22	Err7	57	GND
23	Err6	58	+RRC
24	Err5	59	+12/24V
25	Err4	60	IN-3
26	Err3	61	IN-2
27	Err2	62	IN-1
28	Err1	63	GND-8
29	K12	64	GND-7
30	K10	65	GND-6
31	K8	66	GND-5
32	K6	67	GND-4
33	K4	68	GND-3
34	K2	69	GND-2
35	SA-8 (Voltage output 8)	70	GND-1











Troubleshooting

400 - 900MHz Receiver icon troubleshooting

The troubleshooting Display is located on the receiver side, accessible from the outside. Use the following table to identify faults and corrective action.

Please do check the following website for further information:

<https://troubleshooting.dps-rct.com/en/customer-service-center>

Icon	Description	Action
	Power failure	Check the receiver power supply
	Hardware error	Contact distributor; replace receiver
	CAN error	Contact your distributor
	Standby state due to active stop	Transmitter has been switched off by pressing the STOP button. Release stop button and turn transmitter on
	Standby state due to passive stop	Receiver has lost contact with Transmitter due to interference or Transmitter out of range. Press Start on Transmitter.
	Linked state	Correct link
	Correct ID (link quality as indicated by the bar)	In case of no signal, check if the transmitter is turned on
	Incorrect ID	In case of interference, change frequency channel
	RF signal detected	In case of interference, change frequency channel
	Mask error	Contact your distributor





2.4GHz Receiver Icon Troubleshooting

The troubleshooting Display is located on the receiver side, accessible from the outside. Use the following table to identify faults and corrective action.

In order to reach the internal signaling LEDs, the receiver must be accessible, connected, and the screws located on the receiver lid must be unscrewed using the proper screw driver. The LEDs on the receiver board are POWER, STATUS, DIAG1, DIAG2, ORDER, RELAY, CANERR and CANRUN in that order.

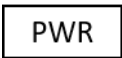
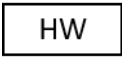
Please do check the following website for further information:

<https://troubleshooting.dps-rct.com/en/customer-service-center>

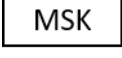
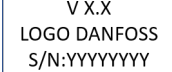
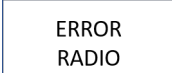
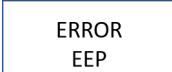
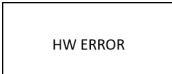
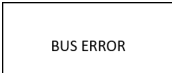
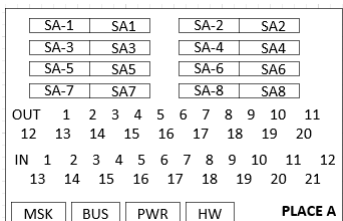
Icon	Description	Action
	Power Fail	Check power supply
	Hardware Error	Replace Receiver
	CAN Error	Verify CAN connections and Status.
	Standby State due to Active STOP	Release STOP button and press START on the transmitter.
	Standby State due to Pasive Stop	Press Start on the Transmitter
	Linked Status	System working Correctly
	Mask Error	Check EEPROM and reprogram if necessary
	Receiver Initializing	Wait
	Radio communication error	Replace Receiver
	EEPROM module missing or corrupt	Check EEPROM and reprogram if necessary
	Hardware Error	Replace Receiver
	CAN Bus configuration Error	Verify CAN Connections, addresses of Expansion boards and Bus terminations
	Standby and Operation Screen	Representation of Inputs and outputs being active at a time



Hydro-Gear

www.hydro-gear.com

Daikin-Sauer-Danfoss

www.daikin-sauer-danfoss.com

Explore our solutions at danfoss.com.

Additional product literature is available at powersource.danfoss.com.

**Danfoss
Power Solutions (US) Company**
2800 East 13th Street
Ames, IA 50010, USA
Phone: +1 515 239 6000

**Danfoss
Power Solutions GmbH & Co. OHG**
Krokamp 35
D-24539 Neumünster, Germany
Phone: +49 4321 871 0

**Danfoss
Power Solutions ApS**
Nordborgvej 81
DK-6430 Nordborg, Denmark
Phone: +45 7488 2222

**Danfoss
Power Solutions Trading
(Shanghai) Co., Ltd.**
Building #22, No. 1000 Jin Hai Rd
Jin Qiao, Pudong New District
Shanghai, China 201206
Phone: +86 21 2080 6201

Danfoss can accept no responsibility for possible errors in catalogues, brochures and other printed material. Danfoss reserves the right to alter its products without notice. This also applies to products already on order provided that such alterations can be made without subsequent changes being necessary in specifications already agreed.
All trademarks in this material are property of the respective companies. Danfoss and the Danfoss logotype are trademarks of Danfoss A/S. All rights reserved.