

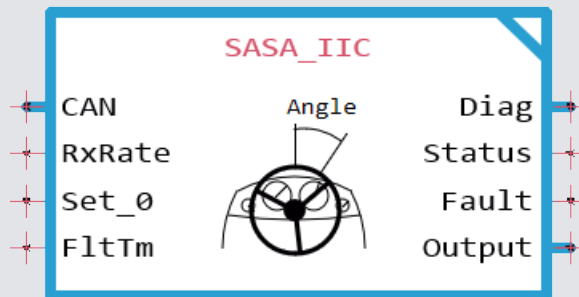

# PLUS+1<sup>®</sup> Compliant SASA\_IIC Function Block



## Revision history

*Table of revisions*

<b>Date</b>	<b>Changed</b>	<b>Rev</b>
February 2026	Updated document for new version of the function block.	0103
September 2015	Changed document number from '11022927' to 'AQ152886481326'	0102
May 2014	First release.	0101

**SASA Function Block Introduction**

Using Namespaces.....4  
Change Namespace Value.....4

**SASA\_IIC Function Block Example**

**SASA\_IIC Function Block Inputs, Outputs, and Parameters**

Inputs.....7  
Outputs.....7  
SASA\_IIC Function Block Fault Logic.....8

## SASA Function Block Introduction

The SASA\_IIC function block receives a signal from a Danfoss Steering Angle Sensor Absolute (SASA) sensor. A SASA sensor detects the change in the angle of a steering wheel then communicates that value over CAN.

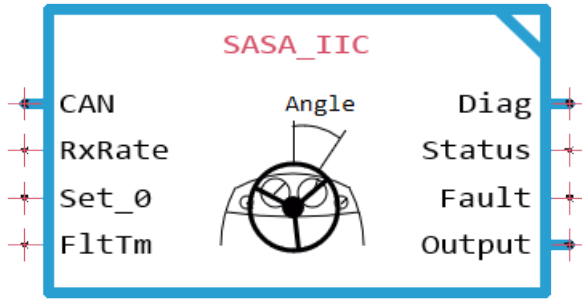

## Using Namespaces

Namespaces help successfully compile an application that uses the same function block more than once.

Change each function block's namespace by setting its **Namespace** value to something unique. The application cannot compile without changing the **Namespace** value.

The **Namespace** value adds a unique prefix to each component name.

Also, to use these function blocks' companion Service Tool screens, include the function block's advanced checkpoint with namespace in the application's compiled .lhx file. Use the function block's **Checkpoints** page to include the checkpoint.

## Change Namespace Value

To successfully compile an application, change the namespace value for function blocks that are used more than once in an application.

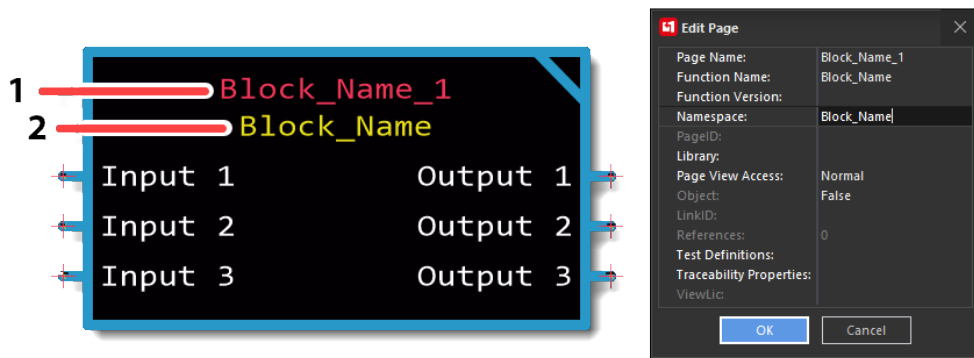

Item	Description
1	Page Name
2	Namespace

1. Enable Query/Change mode.
  - Select **Edit > Query/Change**.
  - Or, press **Q**.
2. Click on the function block to modify the namespace. The **Edit Page** dialog box opens.

3. In the **Namespace** field, enter a unique Namespace value.

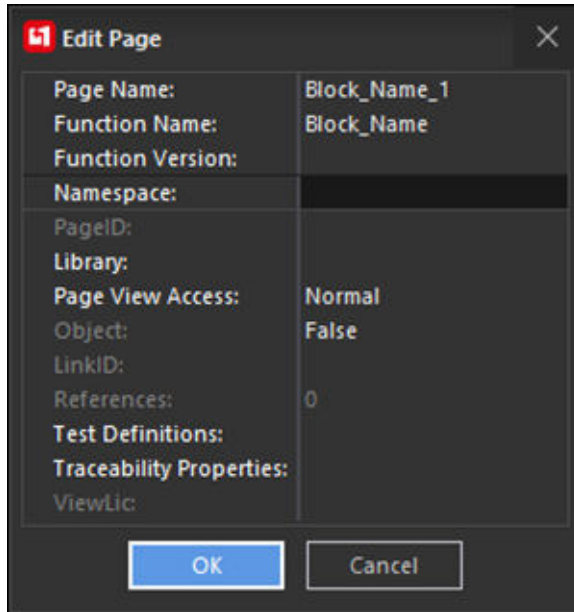

The screenshot shows a dark-themed 'Edit Page' dialog box with a close button (X) in the top right corner. The dialog contains a table of configuration fields:

Page Name:	Block_Name_1
Function Name:	Block_Name
Function Version:	
Namespace:	
PageID:	
Library:	
Page View Access:	Normal
Object:	False
LinkID:	
References:	0
Test Definitions:	
Traceability Properties:	
ViewLic:	

At the bottom of the dialog are two buttons: 'OK' and 'Cancel'.

 **Note**

- **Namespace** values are case-sensitive.
- To save controller memory, use a short namespace value.

4. Click **OK**.

5. Repeat these steps to enter unique namespace values for other identical function blocks.

## SASA\_IIC Function Block Example

This section describes an example application using the SASA\_IIC function block to steer a machine.

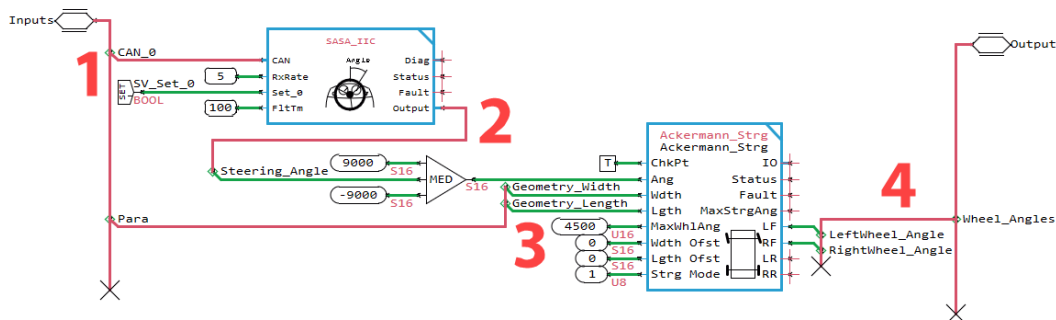

In this image:

1. The **SASA\_IIC** function block receives a signal from the SASA IIC sensor and converts it into a steering angle signal.
  - **CAN** is connected to the **CAN\_0** bus.
  - **RxRate** is set to 5.
  - **Set\_0** is connected to a **Set Value** component named **SV\_Set\_0**.
  - **FltTm** is set to 100.
2. The steering angle signal in the **Output** bus is converted into a signal that is compatible with the **Ang** input on the **Ackermann\_Strg** function block.
  - The **Steering\_Angle** signal is connected to a **Median Value** component which converts the signal to be between -9000 to 9000.
3. The inputs to the **Ackermann\_Strg** function block provide the data to convert into steering signals.
  - The converted **Steering\_Angle** signal is connected to the **Ang** input. This supplies the angle of the steering wheel to the function block.
  - The **Geometry\_Width** and **Geometry\_Length** set the width and length of the wheel base on the machine. These signals come from the **Para** bus.
  - The **MaxWhlAng**, **Wdth\_Ofst**, **Lgth\_Ofst**, and **Strg\_Mode** signals set how the function block operates.
4. The outputs from the **Ackermann\_Strg** function block supply the signals used to steer the machine.
  - **LeftWheel\_Angle** supplies the angle of the left wheel.
  - **RightWheel\_Angle** supplies the angle of the right wheel.

### Note

For more information, refer to the *PLUS+1® GUIDE Control Library User Manual*.

## SASA\_IIC Function Block Inputs, Outputs, and Parameters

This section contains descriptions of inputs, outputs, and parameters in the SASA\_IIC function block.

### Inputs

The following table describes inputs in the SASA\_IIC function block.

*SASA\_IIC Function Block Inputs*

Item	Type	Range	Description
<b>CAN</b>	BUS	---	Sets the CAN port used to communicate with the Danfoss SASA sensor.
<b>RxRate</b>	U8	5, 10, 20	Sets how often the function block receives CAN messages from the steering sensor. [ms]
<b>Set_0</b>	BOOL	T/F	On transition from False to True, it sets the current steering angle position to 0 degrees.
<b>FltTm</b>	U16	<b>OS.ExecTime</b> to 65535	Sets the time that the function block waits before declaring a fault for a lost CAN input. [ms]

### Outputs

The following table describes outputs in the SASA\_IIC function block.

*SASA\_IIC Function Block Outputs*

Output	Type	Range	Description
<b>Diag</b>	BUS	---	This bus provides diagnostic values for troubleshooting. In addition, this bus contains all inputs, parameters, and output signals.
<b>CRC_Value</b>	U16	0 to 65535	The checksum value received with the CAN message from the sensor; used by the function block to determine the validity of the data it receives.
<b>Msg_Counts</b>	U8	0 to 255	A message count value output by the steering sensor, which the sensor increments by one each time it sends a message to the function block.
<b>Tot_Msgs_Dropped</b>	U16	0 to 65535	The total number of CAN messages dropped.
<b>Status</b>	U16	---	Reports the status of the function block. This function block uses non-standard Danfoss status and fault codes. 0x0000: Status OK. 0x0001: Programming pending. The function block writes a parameter to memory. For more information, refer to <a href="#">SASA_IIC Function Block Fault Logic</a> on page 8
<b>Fault</b>	U16	---	Reports runtime errors encountered by the function block. It is a bitwise code where multiple items can be reported at a time. This function block uses non-standard Danfoss status and fault codes. 0x0000: No fault. 0x0001: CRC error. An error occurred during the transmission of the message. 0x0002: Count error. 0x0004: Timeout on CAN bus. 0x0008: Programming error. For more information, refer to <a href="#">SASA_IIC Function Block Fault Logic</a> on page 8

*SASA\_IIC Function Block Outputs (continued)*

Output	Type	Range	Description
<b>Output</b>	BUS	---	BUS containing steering angle signals.
<b>Steering_Angle</b>	U16	0 to 35991	The absolute angle relative to the 0-index point. [0.01 degree]
<b>Angle_Change</b>	S32	-35991 to 35991	The difference in angle between two CAN measurements. [0.01 degree]
<b>Rx_Steer_Data</b>	BOOL	T/F	Indicates that the function block received new angle data in the previous program loop. T: <b>Angle_Change</b> and <b>Steering_Angle</b> values updated during the program loop. F: <b>Angle_Change</b> and <b>Steering_Angle</b> values not updated during the program loop.

**SASA\_IIC Function Block Fault Logic**

The following table describes fault signals from the SASA\_IIC function block and corrective steps to assist resolving the issue. The function block does not use the standard Danfoss status and fault codes.

*Fault Logic*

Fault	Cause	Bit*	Response	Delay†	Latch‡	Correction
CRC error.	A <b>CRC_Value</b> checksum value from the CAN message indicates that an error occurred during the transmission of the message.	1				There is a physical layer problem. Ensure the CAN bus integrity.
Count error.	The function block compared the number of messages it actually received with the <b>Msg_Counts</b> value and found that it had missed receiving two or more messages in a row.	2	Data freezes.	No.	No.	Check that the controller's <b>OS.ExecTime</b> is less than <b>RxRate</b> . ( <b>OS.ExecTime</b> is a global parameter on all devices.)
Timeout on CAN.	The delay in receiving CAN messages exceeds the <b>FltTm</b> setting.	3				There is a physical layer problem. Ensure the CAN bus integrity.
Programming error.	Incorrect <b>RxRate</b> .	4	Function block uses old <b>RxRate</b> .			Apply the correct <b>RxRate</b> .

\*Position of set bit in a 16 bit fault code. Bit 1 is the least significant bit.



**Hydro-Gear**

www.hydro-gear.com

**Daikin-Sauer-Danfoss**

www.daikin-sauer-danfoss.com

Explore our solutions at [danfoss.com](http://danfoss.com).

Additional product literature is available at [powersource.danfoss.com](http://powersource.danfoss.com).

**Danfoss  
Power Solutions (US) Company**  
2800 East 13th Street  
Ames, IA 50010, USA  
Phone: +1 515 239 6000

**Danfoss  
Power Solutions GmbH & Co. OHG**  
Krokamp 35  
D-24539 Neumünster, Germany  
Phone: +49 4321 871 0

**Danfoss  
Power Solutions ApS**  
Nordborgvej 81  
DK-6430 Nordborg, Denmark  
Phone: +45 7488 2222

**Danfoss  
Power Solutions Trading  
(Shanghai) Co., Ltd.**  
Building #22, No. 1000 Jin Hai Rd  
Jin Qiao, Pudong New District  
Shanghai, China 201206  
Phone: +86 21 2080 6201

---

Danfoss can accept no responsibility for possible errors in catalogues, brochures and other printed material. Danfoss reserves the right to alter its products without notice. This also applies to products already on order provided that such alterations can be made without subsequent changes being necessary in specifications already agreed.  
All trademarks in this material are property of the respective companies. Danfoss and the Danfoss logotype are trademarks of Danfoss A/S. All rights reserved.