

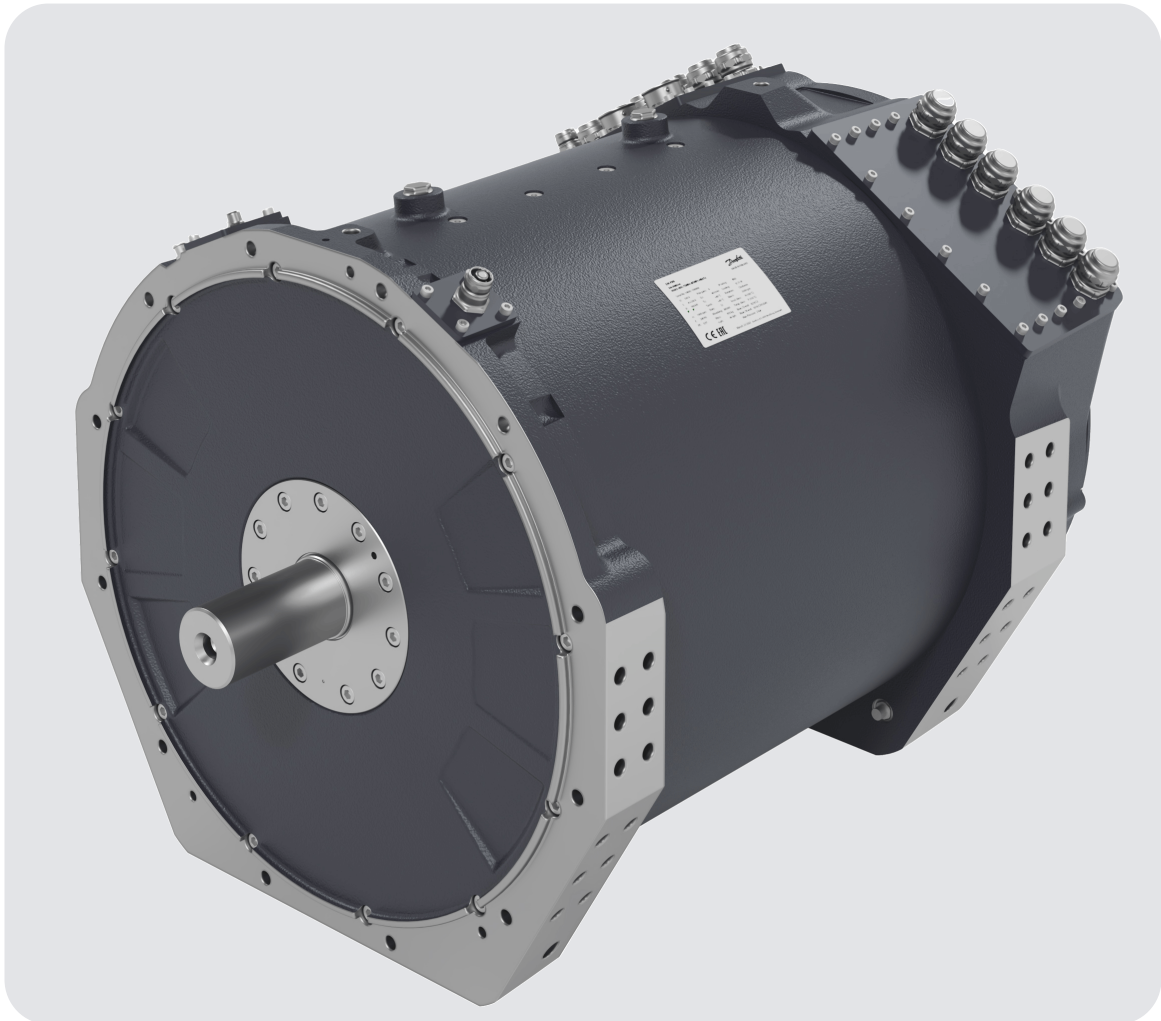

# Motor / Generator

## EM-PMI540B



## Revision history

*Table of revisions*

Date	Changed	Rev
April 2026	Sections updated: Product naming convention, Connection diagram, High voltage connection, Low voltage connections	0104
August 2025	Sections updated: Product naming convention, Operation conditions	0103
June 2025	Official release	0102
September 2024	First edition (preliminary)	0101

**General information**

Intended use of the user guide.....	5
Product naming convention .....	5
Conformity according to standards.....	9
Warranty.....	9
Terms and abbreviations.....	9
Responsibility of the manufacturer.....	10

**Safety information**

General safety statement.....	11
Safety message signal words.....	11
Safety symbols.....	11
Personal protective equipment.....	12
Safety features.....	12
Electromagnetic compatibility (EMC).....	12

**Product overview**

Intended use of the electric machine.....	15
Used technology.....	16
System introduction.....	16
Connections and interfaces.....	17
Rating plate.....	19
Tightening torques.....	20

**Design principles**

System design.....	22
Cooling and temperature measurement .....	22
Insulation lifetime.....	22
Inverter.....	22
Mounting structure.....	24
Supporting structure requirements.....	24
Shaft alignment and load.....	26

**Transportation and storage**

Transportation.....	28
Receiving and unpacking.....	28
Lifting.....	28
Storage.....	30
Extended storage.....	30

**Installation**

Required tools.....	31
Insulation resistance test.....	31
Mechanical installation.....	36
Allowed mounting positions.....	36
Mounting the electric machine.....	37
Cooling connections.....	39
Electrical installation.....	40
Power connections.....	40
High voltage connection.....	40
Connection diagram.....	44
Cable gland assembly and power line connection.....	46
Low voltage connections.....	52
Grounding connections.....	66
Anti-condensation heater connections.....	69

**Operation**

Operation conditions.....	70
Condition monitoring during operation.....	71
Recommended lubricants.....	71
Recommended coolants.....	71
Emergency operation.....	71

**Maintenance**

Regular maintenance.....	73
Cleaning.....	74

Bearings and lubrication.....	75
Cooling system maintenance.....	77

**Dismounting**

**Troubleshooting**

**Aftersales**

Service policy.....	81
Service parts.....	81

**Disposal**

**Storage, installation and maintenance checklists**

## General information

This user guide is the installation, operation and maintenance user guide for the EM-PMI540B electric machines.

## Intended use of the user guide

This user guide provides essential instructions for the safe handling, installation, operation, and maintenance of the electric machine. It is crucial reading for all personnel involved in the installation, operation, or maintenance of the machine and associated equipment.

Strict adherence to all safety warnings and instructions in this user guide is mandatory to prevent personal injury and property damage. Only qualified and authorized personnel, possessing knowledge of relevant health and safety regulations and national legislation, are permitted to handle, install, operate, and maintain the electric machine.

Illustrations in this user guide are examples and may not depict all system features.

Retain this user guide for future reference during installation, operation, and maintenance.

## Product naming convention

In this user guide, EM-PMI family permanent magnet motors and generators are referred to as the electric machine.

Frame model indicates dimensions and electrical characteristics of the electric machine. The following naming convention is used to refer to the electric machine frame model:

- EM-PMI540B-T1500-XXXX+XX
- EM-PMI540B-T2000-XXXX+XX
- EM-PMI540B-T3000-XXXX+XX
- EM-PMI540B-T4000-XXXX+XX

### *The naming codes of the electric machine*

Part of the name	Meaning
EM	Electric Machine
PMIXXX or PMEXXX	Permanent Magnet Internal and a number relative to the diameter of the electric machine, or Permanent Magnet External and a number relative to diameter of the electric machine
TXXXX	Average continuous torque of the motor range, relative to the length of the machine
XXXX	Rated rotation speed
+XX	Options. Standard options are indicated by a star (*).

The power input of the machine may require one or several three phase power systems. This is indicated by a power connection option marking, for example: DUAL or QUAD in the machine model code. One three phases power system can include one or three connection boxes in the machine. The most usual case is when an electric machine has a single connection box, but this is not shown in the machine model code.

- Example: EM-PMI540B-T3000-2000-DUAL

The electric machine can include some of the options available. The options of the electric machine are shown also in the rating plate, following the frame model code. Note! Only options that differ from the standard delivery are indicated. For detailed information on the models, options and characteristics, see product-specific data sheet.

(\*\*\* Option not currently launched. Available on request.

*EM-PMI540B-T1500 options*

Variant	Code	Description	Additional information
High voltage connections	-DUAL	Two galvanically isolated three-phase systems	1 x M32 cable gland per phase, total of 6 pcs M32 cable glands
	-QUAD	Four galvanically isolated three-phase systems	1 x M32 cable gland per phase, total of 12 pcs M32 cable glands -QUAD option enables double-phase connections.
Low voltage connections (signal and auxiliaries)	*	Low voltage connections done with connector	See Connections section of the data sheet
	+LVB1	Low voltage connections done with connection box and terminal strip	D-end: LV connection box with 1 x M16 cable gland + terminal strips N-end: LV connection box with 1 x M25, 2 x M16 and 1 x M12 cable glands + terminal strips
N-end attachment	*	None	
	+NE4 (***)	Male shaft, no flange	DIN 5480 W55x2x26x8f D-end shaft length changes from 80 mm to 100 mm with this option
Foot mounting	*	None	
	+FM1	Foot	Foot mounting, shaft height 315 mm
Bearing insulation	*	Non-insulated bearings	Non-insulated bearings
	+BIN	Insulated bearing in N-end	Insulated bearing in N-end
	+BIA	Insulated bearing in both ends	Insulated bearing in both ends
Shaft grounding	*	None	
	+SG1	D-end shaft grounding	Inbuilt grounding ring
Rotation sensor	*	None	
	+RES1	Resolver	Inbuilt non-contacting resolver, 8-pole pair
Winding temperature sensor	*	Temperature surveillance	DUAL: 6 x PT100 (two-wire) in windings QUAD: 12 x PT100 (two-wire) in windings
	+TEMP5	Redundant temperature surveillance	DUAL: 12 x PT100 (two-wire) in windings QUAD: 24 x PT100 (two-wire) in windings
Bearing temperature sensor	*	None	
	+BTMP1	PT100 in bearings	Plugin connector
Anti-condensation heaters	*	None	
	+HEAT1	One anti-condensation heater	230 V <sub>AC</sub> / 130 W
Machine coating	*	None	
	+C5	High corrosion category	Dark grey RAL7024 Type of coating: Epoxy Minimum number of coats (MNOC): 2 Minimum nominal dry film thickness: 240 µm

*EM-PMI540B-T2000 options*

Variant	Code	Description	Additional information
High voltage connections	-DUAL	Two galvanically isolated three-phase systems	1 x M32 cable gland per phase, total of 6 pcs M32 cable glands
	-QUAD	Four galvanically isolated three-phase systems	1 x M32 cable gland per phase, total of 12 pcs M32 cable glands -QUAD option enables double-phase connections.

*EM-PMI540B-T2000 options (continued)*

Variant	Code	Description	Additional information
Low voltage connections (signal and auxiliaries)	*	Low voltage connections done with connector	See Connections section of the data sheet
	+LVB1	Low voltage connections done with connection box and terminal strip	D-end: LV connection box with 1 x M16 cable gland + terminal strips N-end: LV connection box with 1 x M25, 2 x M16 and 1 x M12 cable glands + terminal strips
N-end attachment	*	None	
	+NE4	Male shaft, no flange	DIN 5480 W55x2x26x8f
Foot mounting	*	None	
	+FM1	Foot	Foot mounting, shaft height 315 mm
Bearing insulation	*	Non-insulated bearings	Non-insulated bearings
	+BIN	Insulated bearing in N-end	Insulated bearing in N-end
	+BIA	Insulated bearing in both ends	Insulated bearing in both ends
Shaft grounding	*	None	
	+SG1	D-end shaft grounding	Inbuilt grounding ring
Rotation sensor	*	None	
	+RES1	Resolver	Inbuilt non-contacting resolver, 8-pole pair
Winding temperature sensor	*	Temperature surveillance	DUAL: 6 x PT100 (two-wire) in windings QUAD: 12 x PT100 (two-wire) in windings
	+TEMP5	Redundant temperature surveillance	DUAL: 12 x PT100 (two-wire) in windings QUAD: 24 x PT100 (two-wire) in windings
Bearing temperature sensor	*	None	
	+BTMP1	PT100 in bearings	Plugin connector
Anti-condensation heaters	*	None	
	+HEAT1	One anti-condensation heater	230 V <sub>AC</sub> / 130 W
Machine coating	*	None	
	+C5	High corrosion category	Dark grey RAL7024 Type of coating: Epoxy Minimum number of coats (MNOC): 2 Minimum nominal dry film thickness: 240 µm

*EM-PMI540B-T3000 options*

Variant	Code	Description	Additional information
High voltage connections	-DUAL	Two galvanically isolated three-phase systems	1 x M32 cable gland per phase, total of 6 pcs M32 cable glands
	-QUAD	Four galvanically isolated three-phase systems	1 x M32 cable gland per phase, total of 12 pcs M32 cable glands
Low voltage connections (signal and auxiliaries)	*	Low voltage connections done with connector	See Connections section of the data sheet
	+LVB1	Low voltage connections done with connection box and terminal strip	D-end: LV connection box with 1 x M16 cable gland + terminal strips N-end: LV connection box with 1 x M25, 2 x M16 and 1 x M12 cable glands + terminal strips
D-end shaft	*	Male shaft, cylindrical	Cylindrical shaft, diameter 70 mm h7
	+S3	Male shaft, spline	DIN 5480 W70x2x30x34x8f
N-end attachment	*	None	
	+NE4 (***)	Male shaft, no flange	Cylindrical shaft, diameter 70 mm h7 (standard) DIN 5480 W70x2x30x34x8f (+S3)
Foot mounting	*	None	
	+FM1	Foot	Foot mounting, shaft height 315 mm

## EM-PMI540B-T3000 options (continued)

Variant	Code	Description	Additional information
Bearing insulation	*	Non-insulated bearings	Non-insulated bearings
	+BIN	Insulated bearing in N-end	Insulated bearing in N-end
	+BIA	Insulated bearing in both ends	Insulated bearing in both ends
Shaft grounding	*	None	
	+SG1	D-end shaft grounding	Inbuilt grounding ring
Rotation sensor	*	None	
	+RES1	Resolver	Inbuilt non-contacting resolver, 8-pole pair
	+RES2	Double resolver	Inbuilt non-contacting resolver, 8-pole pair
Winding temperature sensor	*	Temperature surveillance	DUAL: 6 x PT100 (two-wire) in windings QUAD: 12 x PT100 (two-wire) in windings
	+TEMP5	Redundant temperature surveillance	DUAL: 12 x PT100 (two-wire) in windings QUAD: 24 x PT100 (two-wire) in windings
Bearing temperature sensor	*	None	
	+BTMP1	PT100 in bearings	Plugin connector
Anti-condensation heaters	*	None	
	+HEAT2	Two anti-condensation heaters	2 x 230 V <sub>AC</sub> / 130 W
Machine coating	*	None	
	+C5	High corrosion category	Dark grey RAL7024 Type of coating: Epoxy Minimum number of coats (MNOC): 2 Minimum nominal dry film thickness: 240 µm

## EM-PMI540B-T4000 options

Variant	Code	Description	Additional information
High voltage connections	-DUAL (***)	Two galvanically isolated 3 phase systems	1 x M32 cable gland per phase, total of 6 pcs M32 cable glands
	-QUAD	Four galvanically isolated 3 phase systems	1 x M32 cable gland per phase, total of 12 pcs M32 cable glands
Low voltage connections (signal and auxiliaries)	*	Low voltage connections done with connector	See Connections section of the data sheet
	+LVB1	Low voltage connections done with connection box and terminal strip	D-end: LV connection box with 1 x M16 cable gland + terminal strips N-end: LV connection box with 1 x M25, 2 x M16 and 1 x M12 cable glands + terminal strips
D-end shaft	*	Male shaft, cylindrical	Cylindrical shaft, diameter 70 mm h7
	+S3 (***)	Male shaft, spline	DIN 5480 W70x2x30x34x8f
N-end shaft	*	None	
	+NE4 (***)	Male shaft, no flange	Cylindrical shaft, diameter 70 mm h7 (standard) DIN 5480 W70x2x30x34x8f (+S3)
Foot mounting	*	None	
	+FM1	Foot	Foot mounting, shaft height 315 mm
Bearing insulation	*	Non-insulated bearings	Non-insulated bearings
	+BIN	Insulated bearing in N-end	Insulated bearing in N-end
	+BIA	Insulated bearing in both ends	Insulated bearing in both ends
Shaft grounding	*	None	
	+SG1	D-end shaft grounding	Inbuilt grounding ring
Rotation sensor	*	None	
	+RES1	Resolver	Inbuilt non-contacting resolver, 8-pole pair
	+RES2	Double resolver	Inbuilt non-contacting resolver, 8-pole pair

*EM-PMI540B-T4000 options (continued)*

Variant	Code	Description	Additional information
Winding temperature sensor	*	Temperature surveillance	DUAL: 6 x PT100 (two-wire) in windings QUAD: 12 x PT100 (two-wire) in windings
	+TEMP5	Redundant temperature surveillance	DUAL: 12 x PT100 (two-wire) in windings QUAD: 24 x PT100 (two-wire) in windings
Bearing temperature sensor	*	None	
	+BTMP1	PT100 in bearings	Plugin connector
Anti-condensation heaters	*	None	
	+HEAT2	Two anti-condensation heaters	2 x 230 V <sub>AC</sub> / 130 W
Machine coating	*	None	
	+C5	High corrosion category	Dark grey RAL7024 Type of coating: Epoxy Minimum number of coats (MNOC): 2 Minimum nominal dry film thickness: 240 µm

## Conformity according to standards

The electric machine has been designed to be in conformity with the following directives and to meet the requirements specified in the following standards:

### *Applicable directives and standards*

Standard	Explanation
Low Voltage Directive 2006/95/EC (until 19.4.2016) and Low Voltage Directive 2014/35/EU (from 20.4.2016 onwards)	Electrical equipment means any equipment designed for use with a voltage rating of between 50 and 1000 V for alternating current. This electric machine is subject to the Low Voltage Directive 2006/95/EC or 2014/35/EC.
IEC 60034-1:2010	Rotating electrical machines - Part 1: Rating and performance
IEC 60034-5:2001/A1:2007	Rotating electrical machines - Part 5: Degrees of protection provided by the integral design of rotating electrical machines (IP code) - Classification
IEC 60034-6:1991	Rotating electrical machines - Part 6: Methods of cooling
IEC 60034-7:1992/A1:2001	Rotating electrical machines - Part 7: Classification of types of construction, mounting arrangements and connection box position (IM Code)
IEC 60034-8:2007/A1:2014	Rotating electrical machines - Part 8: Terminal markings and direction of rotation
IEC 60034-14:2004/A1:2008	Amendment 1 - Rotating electrical machines - Part 14: Mechanical vibration of certain machines with shaft heights 56 mm and higher - Measurement, evaluation and limits of vibration severity.

It should be noted, that the commissioning party is responsible for establishing the conformity of the end product with the Directive 2006/42/EC, when the EM-PMI electric machines are fitted into machinery.

## Warranty

Danfoss offers warranty against defects in workmanship and materials for its products. For more information, see General terms and conditions of sale at <https://www.danfoss.com/en/terms/sales-conditions/>.

Warranty validity requires adherence to the instructions in this document and all related materials, including product installation and maintenance guidelines, and compliance with all applicable national standards and regulations.

The warranty does not cover defects resulting from improper or negligent use, operation, or installation; failure to perform regular preventive maintenance; or damage caused by external factors or the use of non-Danfoss supplied/recommended equipment and components.

Any unauthorized repairs or modifications made without Danfoss' prior written consent will invalidate the warranty.

## Terms and abbreviations

The following tables define symbols, terms, and abbreviations that may appear in this user guide.

*Symbols*

Symbol	Variable	Unit
U	Rated voltage (phase-to-phase AC)	V <sub>rms</sub>
I	Rated current (AC)	A <sub>rms</sub>
P	Rated Power (S1)	kW
T	Rated torque (S1) at rated speed	Nm
T <sub>max</sub>	Maximum torque	Nm
n	Rated speed	rpm
Max n	Maximum speed	rpm
f	Rated supply frequency at nominal speed	Hz
PF	Power factor (cosφ)	
Q <sub>c</sub>	Rated coolant liquid flow	l/min
T <sub>c</sub>	Rated coolant liquid input temperature	°C
T <sub>amb</sub>	Rated ambient temperature	°C
RES_COS	Cosine signal received from the resolver	deg
RES_SIN	Sinusoidal signal received from the resolver	deg
Ω (Ohm)	Resistance	Ω

*Terms and abbreviations*

Term / abbreviation	Explanation
Resolver	Rotation meter in electric machines, used for measuring degrees of rotation
AC	Alternating current
DC	Direct current
GND	Ground in electrical connections
PMSM	Permanent Magnet Synchronous Machine
SRPM	Synchronous Reluctance assisted Permanent Magnet
S1	Duty type according to the IEC60034; Continuous running duty
S9	Duty type according to the IEC60034; Duty with non-periodic load and speed variations

**Responsibility of the manufacturer**

Danfoss guarantees the safety, reliability, and performance of the electric machine only when the following conditions are met:

- Handling, mounting, installation, operation, and maintenance are performed by qualified and authorized personnel.
- The system installation adheres to all applicable regulations.
- The electric machine is operated according to the instructions in this user guide.
- The electric machine is installed, maintained, and serviced according to the instructions in this user guide.

## Safety information

### General safety statement

- Designed for use as a component in industrial and commercial installations, the electric machine requires that the end product comply with all relevant regulations.
- The electric machine cannot be used in hazardous areas unless specifically designed for that purpose.
- Only qualified personnel familiar with health and safety requirements and national legislation should install, use, and maintain this electric machine. Failure to comply with these instructions may void all applicable warranties.
- These instructions are essential for the safe and correct installation, operation, and maintenance of the electric machine. Make sure everyone who installs, operates, or maintains the electric machine or related equipment has access to and understands these instructions.
- This user guide covers electric machines with high voltage and rotating parts that can cause serious or fatal injuries. To prevent injury, always follow safety precautions.

### Safety message signal words

Safety message signal words indicate the severity of a potential hazard.

**DANGER** Indicates an imminently hazardous situation which, if not avoided, will result in death or serious injury.









**WARNING** Indicates a potentially hazardous situation which, if not avoided, could result in death or serious injury.

**CAUTION** Indicates a potentially hazardous situation which, if not avoided, may result in minor or moderate injury. CAUTION may also alert against unsafe practices.

**NOTICE** Indicates a potentially hazardous situation which, if not avoided, could result in property damage.





### Safety symbols

The following safety and information symbols are used in this user guide and on the electric machine.

	<b>Danger</b> This symbol warns of a dangerous situation that could result in serious injury or death. Do not perform the action indicated by this symbol.
	<b>General warning</b> This symbol indicates a potentially hazardous situation.
	<b>Electric shock warning</b> This symbol indicates the presence of dangerous voltage that could cause electric shock.
	<b>Burn warning</b> This symbol warns of a hot surface that could cause burns. The device should be installed to prevent contact with its potentially hot surfaces.
	<b>Magnet warning</b> This symbol warns of a strong magnetic field that could be harmful to people or property.
	<b>Rotating shaft warning</b> This symbol warns of a strong rotating shaft that could be harmful to people or property.
	This symbol indicates that the following content is for general information.
	This symbol indicates that you need to refer to the user guide for instructions.

## Personal protective equipment

To prevent injury during handling, installation, and maintenance of the electric machine, use appropriate personal protective equipment when necessary.

	<b>Wear safety goggles or a mask when working on the electric machine. Bearing grease, melted nitrile rubber (from the radial lip seal), glycol, or other fluids could splash and cause permanent eye damage.</b>
	<b>Wear hearing protection when working on the electric machine. Exposure to noise levels above 85 dBA can cause hearing damage.</b>
	<b>Wear a helmet when lifting the electric machine to protect yourself from potential head injuries caused by falling objects.</b>
	<b>Wear cut-resistant gloves when handling and maintaining the electric machine to protect against cuts.</b>
	<b>Wear protective footwear when lifting or moving the electric machine to prevent foot injuries in case of lifting system or bracket failure.</b>



## Safety features

The number of the temperature sensors in the windings of the electric machine follows the requirements of the standards. The amount of the sensors depends on the options chosen. The temperature signal(s) can be read out from the measurement connector of the electric machine. You can connect the temperature signal to the temperature surveillance pin in the inverter (EC-C) and make sure that the inverter has the machine temperature protection feature activated.

The electric machine can be ordered with bearing temperature measurement. This option includes one PT100 temperature sensor (four wire) at both D-end and N-end bearings. The signal can be read out using a separate connector at both ends.

The electric machine has leakage sensors (2 pcs) at the lower part of the electric machine. This feature is useful in moist conditions to detect possible excessive water in contact with the electric machine. Separate connectors for both leakage signals exist.

## Electromagnetic compatibility (EMC)

	<b>When connecting to other equipment, ensure that only specified and compatible components of the system are used.</b>
	<p><b>Individuals with heart pacemakers, metal implants, or hearing aids should be aware that electric machines generate magnetic and electromagnetic fields that can be a health hazard. These individuals should consult a doctor due to the risks posed by current-carrying conductors and permanent magnets before entering the following areas:</b></p> <ul style="list-style-type: none"> <li>• <b>Areas where electrical equipment and parts are operating</b></li> <li>• <b>Areas where electrical equipment with permanent magnets is stored, assembled, operated, or repaired</b></li> </ul> <p><b>If necessary, perform a dedicated EMC test on the installation.</b></p>

Electromagnetic compatibility (EMC) is the ability of electrical equipment to function correctly in its electromagnetic environment without causing interference to other devices. Meeting EMC requirements is a legal obligation for all equipment used within the European Economic Area (EEA)

Our products are designed with high standards of EMC in mind. Connect the power cables and groundings along the instructions in this user guide to achieve the required level of electromagnetic interference (EMI) shielding.

The installer is responsible for ensuring that the equipment or system into which this product is integrated complies with the EMC legislation of the country where it will be used. Within the European Union, equipment incorporating this product must comply with the EMC Directive 2014/30/EU.

## Product overview



**This user guide covers the following electric machines:**

- **EM-PMI540B-T1500**
- **EM-PMI540B-T2000**
- **EM-PMI540B-T3000**
- **EM-PMI540B-T4000**

These electric machines are specifically designed for demanding heavy-duty, marine, and transportation applications. They offer enhanced reliability, reduced size and weight, and improved efficiency compared to conventional products.

Applications include:

- Electric propulsion motors and generators in hybrid marine vessels, mobile work machines, and parallel hybrid buses
- Traction motors and generators in electric or hybrid-electric mobile work machines and buses

These electric machines use Synchronous Reluctance assisted Permanent Magnet (SRPM) motor technology, which offers several advanced features:

- Extremely compact and robust structure
- High efficiency across the entire operating range
- Liquid-cooling using a water-glycol mixture
- Minimum coolant flow required
- High coolant temperatures permissible
- IP67 rated enclosure for maximum reliability
- Multiple mounting possibilities
- Enhanced speed and torque capabilities compared to conventional PM machines
- High starting torques, delivering immediate torque to a stationary wheel
- Optimized speed range to accommodate the most common gear ratios used in heavy mobile machinery

*EM-PMI540B-T1500*

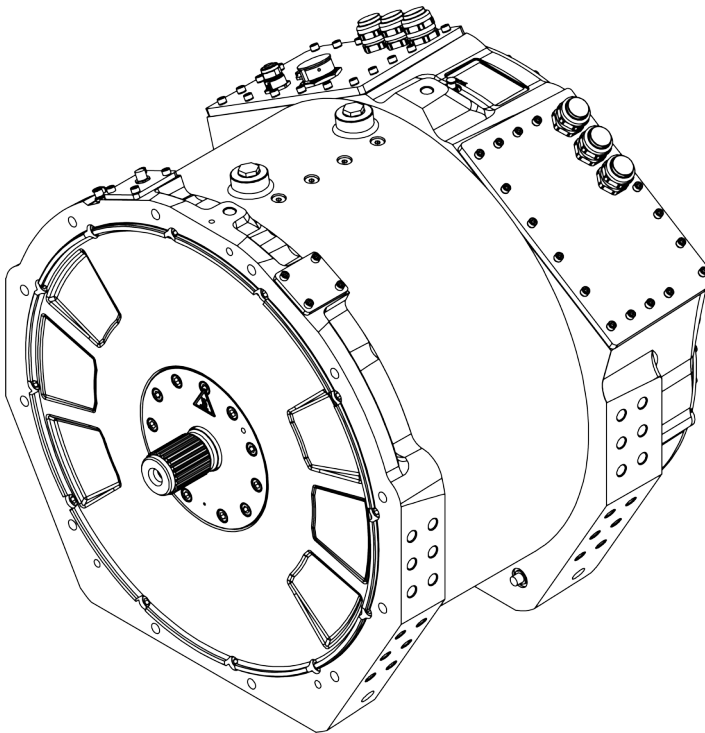

EM-PMI540B-T2000

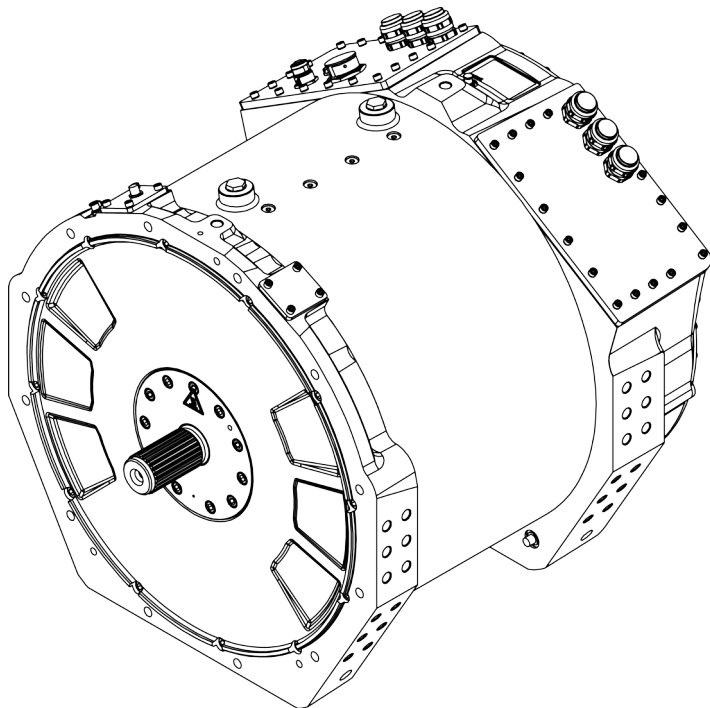

EM-PMI540B-T3000

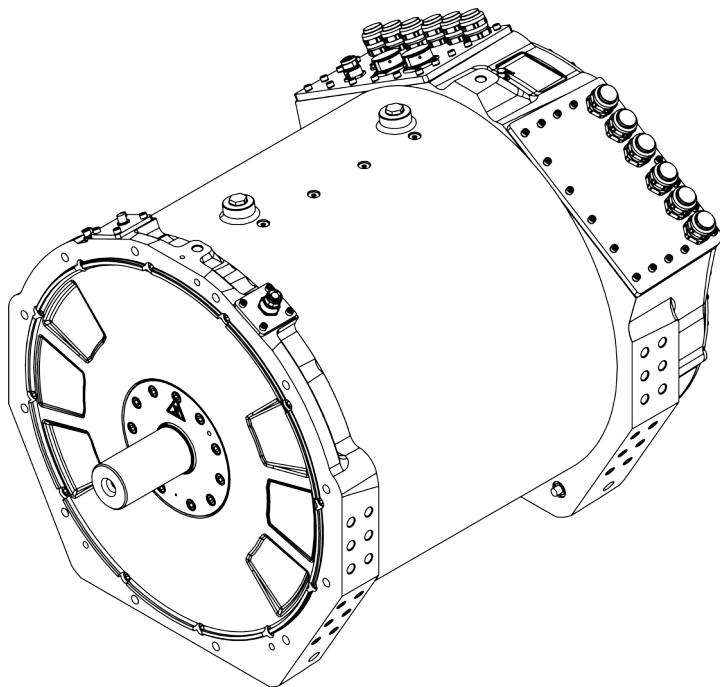

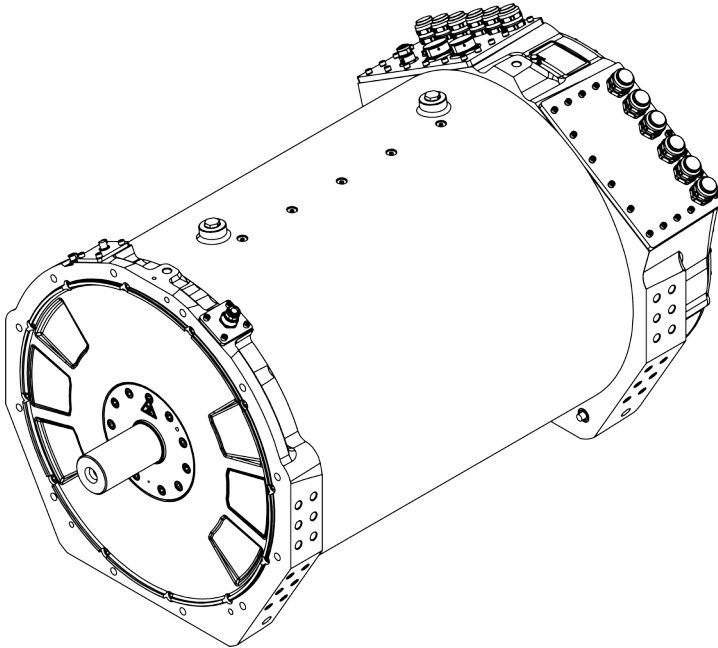
*EM-PM1540B-T4000*

To provide optimal solutions for various applications, these electric machines are available in several frame models (sizes). They also offer options for shaft type, attachment interface, bearings, connection box attachment, rotation sensors, and temperature sensors.

### Intended use of the electric machine

This electric machine is intended to operate as a motor or generator and is designed to be integrated into machinery, such as:

- Power train of a marine vessel, transportation vehicle or a heavy duty work machine
- Power generation equipment.

This electric machine requires an inverter or inverters to supply three-phase alternating current for power and control. It is not designed for direct online operation.

When used for power generation, these electric machines are intended to be driven by a prime mover, such as an internal combustion engine, and controlled by the inverter or inverters mentioned above.

This electric machine is exclusively for professional use and should only be operated and maintained by trained professionals.

### ***Prohibited uses of the electric machine***

The following uses, handling procedures, and maintenance practices are prohibited (this list is not exhaustive):

- Using the electric machine for purposes not specified in this user guide
- Failing to comply with this user guide, safety signs, and rating plate information of the electric machine
- Operating, adjusting, or performing maintenance on the electric machine before reading this user guide
- Operating the electric machine beyond its designed limits
- Using non-genuine service parts or parts with incorrect materials, potentially causing corrosion and eventual mechanical failures
- Operating and maintaining the electric machine without using the appropriate personal protective equipment
- Using electric machine parts, such as the frame, shaft end, or terminal box, for climbing or to support other structures
- Subjecting the electric machine to any kind of impact forces (for example, hitting, hammering, or dropping objects)
- Operating the electric machine using electrical connections not described in the user guide or other documentation
- Operating the electric machine when connections or cable glands are not properly tightened
- Operating the electric machine with power cables that are not routed according to the instructions
- Operating the electric machine without a cooling system that is correctly dimensioned and operating

- Operating the electric machine without following the bearing lubrication instructions
- Touching the electric machine's connection terminals or performing maintenance or adjustments while the power is connected
- Lifting the electric machine from incorrect lifting points or without appropriate lifting equipment
- Lifting additional loads with the machine
- Storing the electric machine outdoors in wet or dusty environments
- Storing the electric machine without proper support to prevent it from rolling or falling
- Using the electric machine in potentially explosive environments
- Allowing dirt or liquid to enter the electric machine or connection box
- Using cables that cannot withstand the maximum currents of the electric machine

## Used technology

As a Synchronous Reluctance assisted Permanent Magnet (SRPM) machine, this electric machine offers several benefits compared to standard permanent magnet (PM) and traditional induction machine (IM) technologies. SRPM technology combines the advantages of both PM and Synchronous Reluctance technology, resulting in increased torque capability over a wide speed range and the ability to produce torque at higher speeds. The machine also maintains good efficiency at lower speeds.

The supply current to the machine's stator windings generates a rotating magnetic field that rotates the rotor, which contains permanent magnets. In a synchronous permanent magnet machine, the rotor (shaft) rotation is synchronized with the frequency of the power supply current. The reluctance technology maximizes the machine's pull-out torque.

The rotor's permanent magnets feature a salient-pole design with embedded permanent magnets within the rotor structure. This design enhances the electric machine's mechanical stability and enables higher-speed operation. A simplified illustration of the magnet topology is shown below.

*Machine topology*

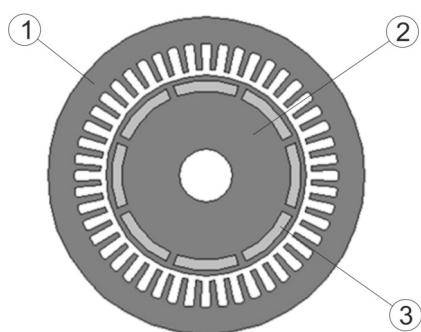

1	Electric machine stator and stator windings
2	Electric machine rotor
3	Permanent magnets in the rotor

## System introduction

Danfoss delivers complete electric drivetrain solutions for heavy mobile machinery, marine vessels, and buses, enabling seamless transitions to hybrid electric (HEV) and fully electric (EV) vehicles. Our integrated systems reduce fuel consumption, emissions, and noise pollution.

### Overview of the Danfoss drive train system

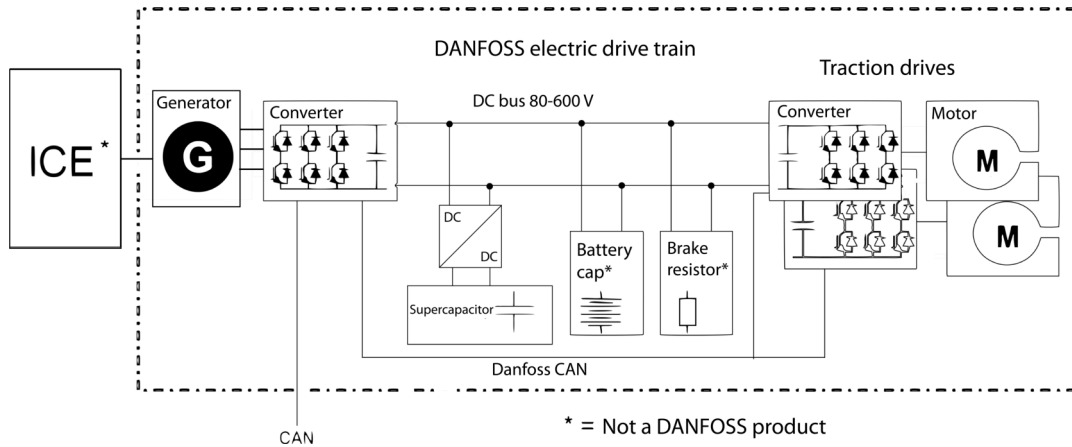

The electric machines are liquid cooled with water-glycol mixture. For more information, see [Cooling connections](#).

The electric machines incorporate a low-voltage connector for accessing various sensor signals. Depending on the machine configuration, this connector provides access to temperature and resolver data. For more information about the connection, see [Low voltage connections](#).

It is recommended to use a Danfoss inverter for optimized performance.

## Connections and interfaces

Electric machines are mechanically and electrically integrated into machinery or power generation equipment.

Mechanical interfaces:

- Lifting eyes
- Foot mounting and additional flange connection (D-end)
- Shaft connection
- Cooling system connections (bores)
- Grease escape/fill connections; maintenance use only
- Air ventilation plug
- Vibration sensor connection point

Electrical interfaces:

- Power connections through the connection box
- Measurement connector (connection through the connection box) / Measurement signal connectors
- Anti-condensation heater connection (+HEAT1) (through the connection box) / Anti-condensation heater connections (+HEAT2 option)
- Bearing temperature connectors (+BTMP1 option)
- Leakage sensor connectors

## Connections and interfaces

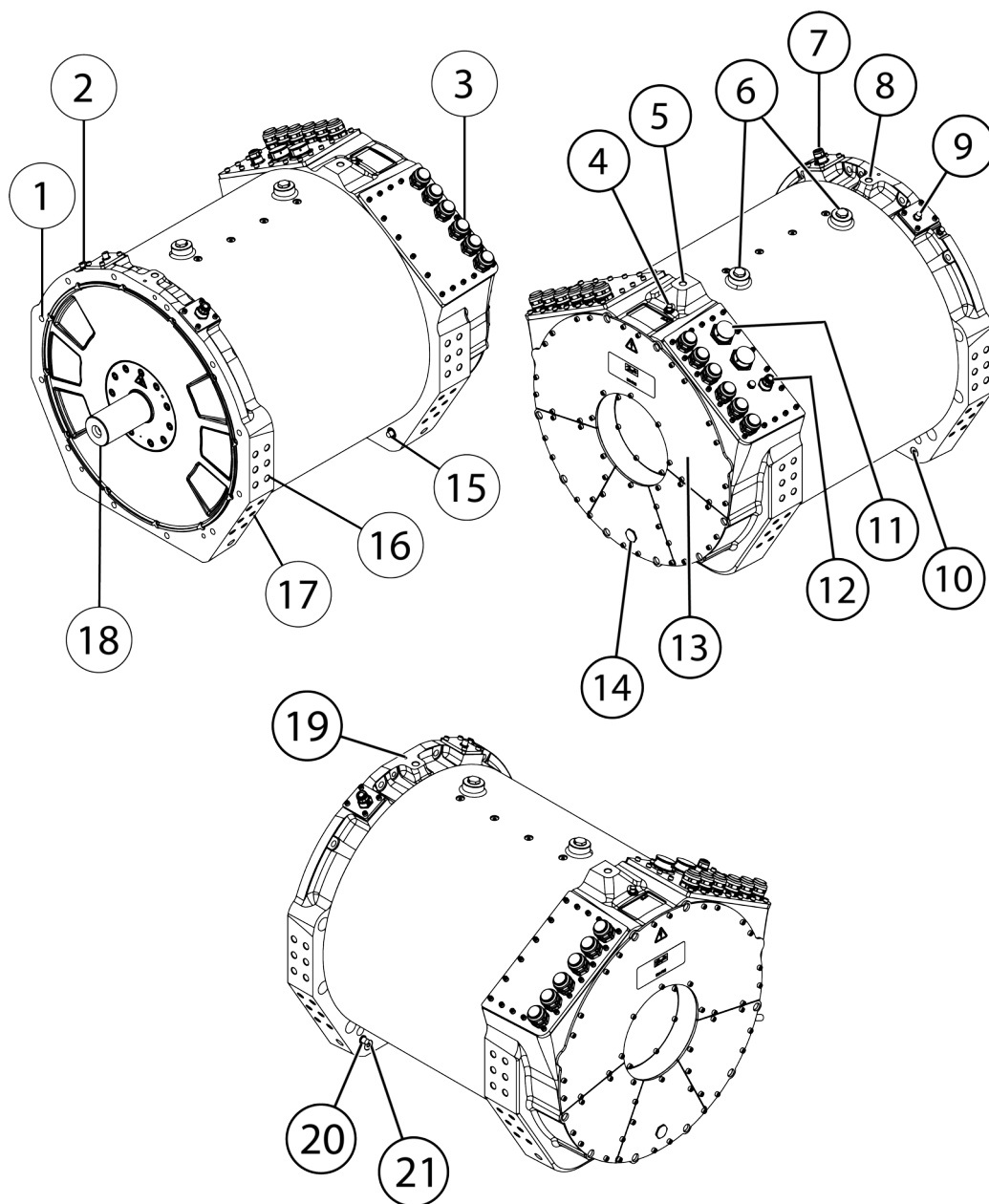

1	Mounting bores (12 pcs)
2	Grease inlet D-end bearing (DIN 71412)
3	Power connection
4	Grease inlet N-end bearing (DIN 71412)
5	Lifting point
6	Cooling system connection
7	Optional: Anti-condensation heater connector
8	Lifting point
9	Bearing temperature measurement connector
10	Grease escape connection (alternative to item 21)
11	Low voltage connector - winding temperature sensors and resolver connections - bearing temperature measurement sensor connector
12	Anti-condensation heater connector

13	Connection boxes
14	Grease escape connection
15	Leakage sensor connection
16	Side mounting bores
17	Foot / V- mounting bores
18	Shaft connection
19	Vibration sensor connection
20	Leakage sensor connection
21	Grease escape connection (alternative to item 10)

## Rating plate

Each electric machine has a rating plate which can be found on the machine frame. The rating plate contains machine rating and identification. The rating values in the Figure below are not correct for this machine. See the rating plate on the machine and data sheets for the correct values.

### Rating plate

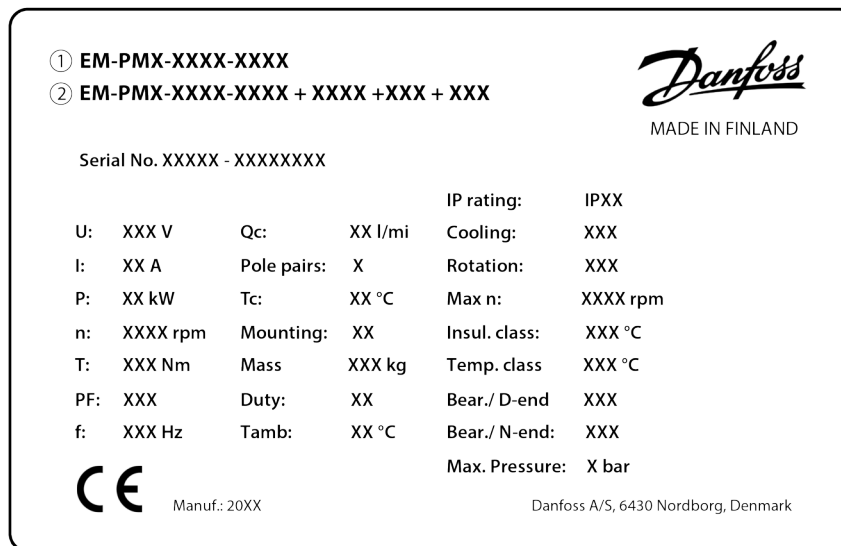



### Rating plate fields

Field	Explanation	Unit
1	Electric machine product family: EM-PMI or EM-PME	
2	Electric machine type code and options	
Serial No.	Serial number	
U	Rated voltage (phase-to-phase AC)	V <sub>rms</sub>
I	Rated current (AC)	I <sub>rms</sub>
P	Rated power (S9) according to IEC60034-1	kW
n	Rated speed	rpm
T	Rated torque (S9) at rated speed	Nm
PF	Power factor	
f	Rated supply frequency at nominal speed	Hz
Q <sub>c</sub>	Rated coolant liquid flow	l/min
Pole pairs	Number of magnetic pole pairs of the machine	
T <sub>c</sub>	Rated coolant liquid input temperature	°C

*Rating plate fields (continued)*

Mounting	Allowed mounting position according to IEC60034-7	
Mass	Mass of the electric machine	kg
Duty	Defined rotating electric machine duty cycles by IEC60034-1 standard	
T <sub>amb</sub>	Rated ambient temperature	°C
IP rating	Enclosure class according to IEC60034-5	
Cooling	Cooling method according to IEC60034-6	
Rotation	Direction of rotor rotation with default phase order. Observed facing the D-end.	
Max n	Maximum rotation speed	rpm
Insul. class	Temperature rating (class) of insulation of the electric machine according to IEC60034-1	
Temp. class	Temperature rating (class) of individual insulation materials of the insulation according to IEC60034-1	
Bear. / D-end	Bearing type (types) in the D-end of the electric machine	
Bear. / N-end	Bearing type in the N-end of the electric machine	
Max. pressure	Cooling liquid max pressure	
CE	Declaration of conformity with the requirements of EU legislation	

## Tightening torques

	<b>Unless otherwise specified, the acceptable tightening torque range is within +/- 5 % of the stated value.</b>
	<b>Use threadlocking adhesive for RST, that is, stainless steel bolts to avoid breakage.</b>

Do not install dry screws or other fastening equipment. Always add suitable lubrication, for example Wurth HSP 1400, to prevent excess friction.

Connection	Tightening torque
Connection box (High voltage boxes at N-end) cover plate screws, M6	11 Nm
Low voltage box cover plate screws, M6 (only if +LVB1)	11 Nm
Cable lug	15 Nm

*Tightening torques for different mounting options*

	V & S (M16)	Feet (M16)	Flange (M12)
Torque (Nm)	235	280	80
Bolt strength class	10.9	10.9	8.8

Values in the table are calculated with:

- All mountings: hardened washers under bolt head
- Feet & Flange mounting: 0.12 friction factor under bolt head and in the thread
- V & S mounting: 0.12 friction factor under bolt head and 0.14 friction factor in the thread
- V & S mounting: 24 mm thread engagement

*Tightening torques to use unless otherwise noted*

	8.8	10.9	12.9
Thread	Nm	Nm	Nm
M5	7	10	11
M6	11	17	19





M8	27	40	47
M10	54	79	93
M12	93	137	160
M14	148	218	255
M16	230	338	395

## Design principles

This Chapter describes design principles that must be taken into account when designing the system using the electric machine.

## System design

### Cooling and temperature measurement

	<b>Do not operate the electric machine without correctly dimensioned and operating cooling system.</b>
	<b>Mount the electric machine in correct position, see Chapter <i>Allowed mounting position</i>.</b>
	<b>When you connect the cooling system make sure that the cooling medium flows freely in and out from the electric machine with the cooling medium flow equal or higher than rated.</b>
	<b>The cooling medium temperature at the inlet of the electric machine must be lower or equal to the rated temperature.</b>

See more detailed information about coolant connection bore specifications, required coolant liquid flow and other specifications in the product data sheet. Rated values can be found from the electric machine rating plate.

The number of the temperature sensors in the windings of the electric machine follows the requirements of the standards. The amount of the sensors depends on the options chosen. The temperature signal(s) can be read out from the measurement connector of the electric machine.

You can connect one temperature signal to the temperature surveillance pin in the inverter (EC-C1200) and make sure that the inverter has the machine temperature protection feature activated.

The maximum allowed winding temperature of the electric machine is shown in the rating plate and in the data sheet.

The PT100 temperature sensor characteristics are: resistance 100  $\Omega$  at 0°C temperature, and the resistance increases 0.385  $\Omega$  per each 1°C increase of temperature.

### Insulation lifetime

	<b>Factors like thermal cycling, environmental conditions, moisture, and vibration impact the electric machine's insulation lifespan. This lifespan is a calculated prediction and is not tested in practice.</b>
---	---

The insulation lifetime expectancy of the electric machine is shown in the following table.

Insulation class	Continuous measured stator temperature	Lifetime expectancy
H 180°C	150°C	100 000 h
H 180°C	175°C	20 000 h

### Inverter

The electric machine is intended to be powered and controlled with an inverter capable of supplying three-phase alternating current and that is capable of controlling the electric machine. The electric machine is not suitable for direct online use.

If the electric machine is driven with an inverter from a supplier other than Danfoss Editron, the electric machine performance may differ from rated values. The optimum performance of the electric machine is obtained with Danfoss Editron inverters. These inverters are:

- Compact and light.
- Liquid cooled.
- Tolerant to high mechanical vibration (10 G) and shock (50 G).
- Efficient, efficiency > 98 %.
- Reliable, no moving components.



**Do not exceed the maximum rotation speed of the electric machine.**

EC-C1200



*Schematic of the inverter powerstage*

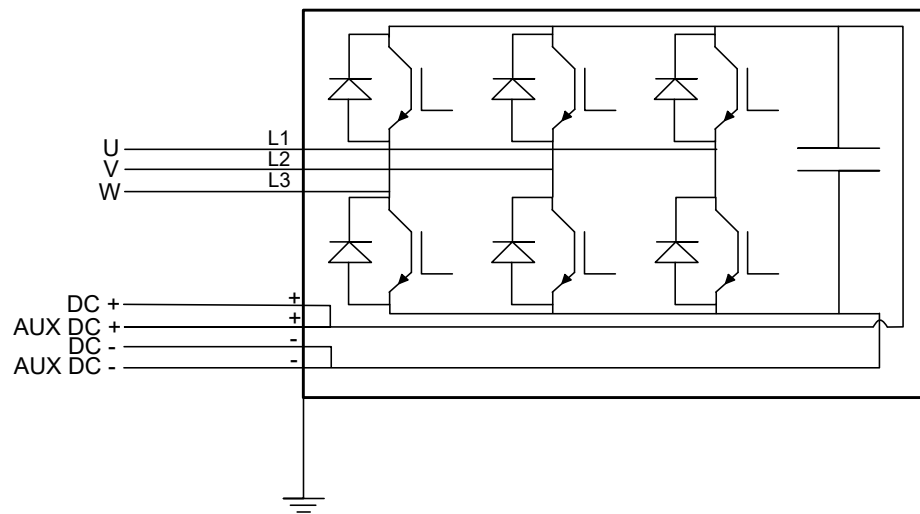

The main machine power driving parameters are shown in the machine rating plate. For more information, contact Danfoss representative.

You can connect one of the temperature signals (from the low voltage connector) to the temperature surveillance pin in the inverter and make sure that the inverter has the machine temperature protection feature activated.

## Mounting structure

### Supporting structure requirements



**Do not install the electric machine near or in direct contact with easily flammable materials. The surface of the electric machine can be hot.**

The mating housing arrangement of the electric machine must be secure and sufficiently rigid to prevent vibrations and mechanical failures. Necessary actions should be taken to avoid corrosion on the mating housing arrangement.

The supporting structure for the electric machine must be such that the electric machine can be mounted using its allowed mounting positions, see Chapter *Allowed mounting positions*.

The mounting space must be adequate for the electric machine mounting and possible auxiliary components. See the length and the diameter data of the electric machine from the product drawing. Main dimensions of the electric machine are shown in the Figure below (the illustration may differ from the actual electric machine).

The electric machine has a SAE 1/2 transmission housing D-end flange. A SAE 1/2 flywheel housing is required as mating flange. The connection boxes are connected to N-end.

## Main dimensions of the electric machine

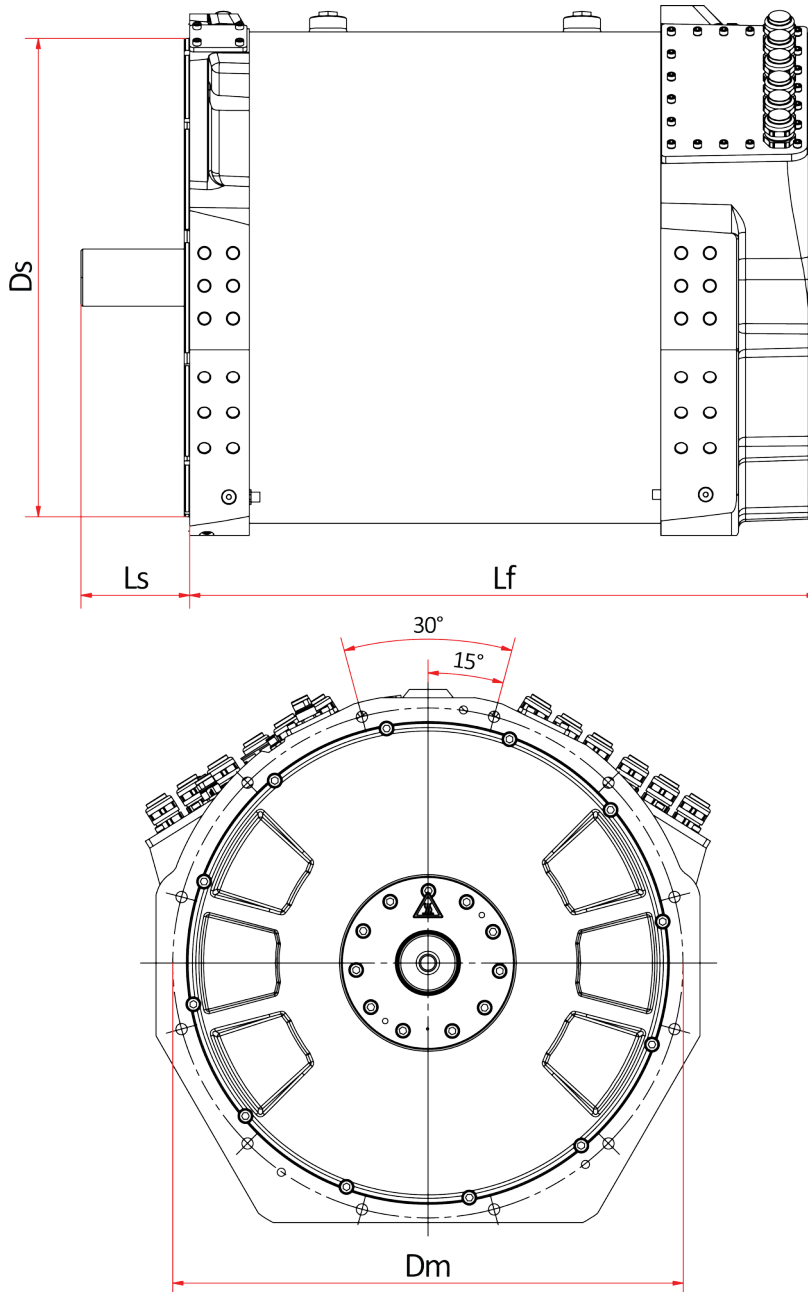

Symbol	Explanation
$L_f$	Length of the electric machine frame.
$L_s$	Length of the shaft (from the end of the shaft to the electric machine D-end mounting shoulder).
$D_m$	Diameter of the flange mounting bore circle.
$D_s$	Diameter of the mounting shoulder.

## Electric machine measurements

Measurement (mm)	T1500	T2000	T3000	T4000
$L_f$	534	614	766	1014
$L_s$	80.5	100.5	132.5	132.5
$D_m$	ø 619.12	ø 619.12	ø 619.12	ø 619.12
$D_s$	ø 584.2	ø 584.2	ø 584.2	ø 584.2

For all dimensions of the electric machine, see the product drawings.

## Shaft alignment and load



**Proper alignment is crucial to prevent bearing overloads, premature bearing failures, excessive vibration, and shaft failures.**

**Use of flexible coupling is recommended. However, it does not compensate for excessive misalignment, so always perform a proper alignment procedure regardless of the coupling type used.**

For electric machines EM-PMI540B-T1500 and EM-PMI540B-T2000, the type of the electric machine shaft is DIN 5480 W55x2x26x8f. The flange type is SAE 1/2 transmission housing.

For electric machines EM-PMI540B-T3000 and EM-PMI540B-T4000, the type of the electric machine shaft is cylindrical shaft with diameter of 70 mm h7 and contact length of 130 mm. The flange type is SAE 1/2 transmission housing.

Alignment between the shaft and mating structure must be accurate. Proper alignment is crucial to prevent bearing overloads, premature bearing failures, excessive vibration and shaft failures. Flexible coupling does not compensate for excessive misalignment, so always perform a proper alignment procedure regardless of the coupling type used.

The misalignment can be parallel or angular misalignment, or combination of those. With parallel misalignment, the center lines of both shafts are parallel but they are offset. With angular misalignment, the shafts are at an angle to each other. Figures below illustrate the parallel and angular misalignment.

### *Parallel alignment of the shaft and mating structure*

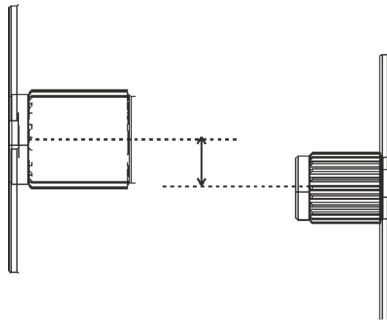

### *Maximum parallel misalignment values*

	Non-flexible coupling *	Flexible coupling *
rpm	mm	mm
0-1000	0.07	0.13
1000-2000	0.05	0.10
2000-3000	0.03	0.07
3000-4000	0.02	0.05
4000-6000	< 0.02	0.03

\* The values given might differ between coupling types.

### *Angular alignment of the shaft and mating structure*

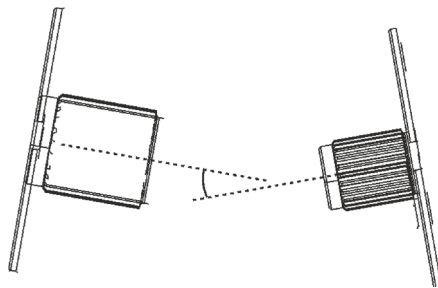

*Maximum angular misalignment values*

	Non-flexible coupling *	Flexible coupling *
rpm	mm / 100 mm	mm / 100 mm
0-1000	0.06	0.10
1000-2000	0.05	0.08
2000-3000	0.04	0.07
3000-4000	0.03	0.06
4000-6000	< 0.03	0.05

\* The values given might differ between coupling types.

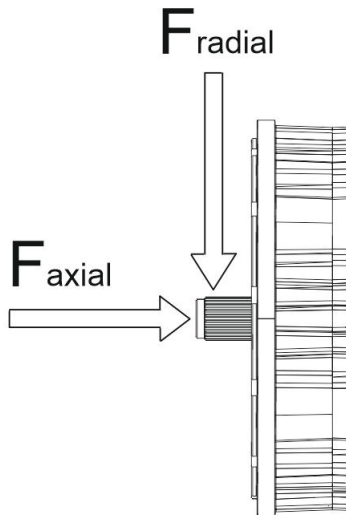

**The maximum external force directed to the shaft axially and radially may not exceed machine specific values. For more information, see document DOC-000454. Calculate the relevant values with the help of the document. Contact Danfoss service at <https://danfosseditron.zendesk.com/hc/en-gb> or send email to [editron.service@danfoss.com](mailto:editron.service@danfoss.com) to obtain the document.**

*External shaft forces of the electric machine*

## Transportation and storage



### Transportation

	<b>Heavy equipment. Handle with care during transportation.</b>
---	---

Electric machine is shipped in first class condition. It has been inspected and packed correctly to prevent damage from ordinary handling during shipment. During transportation, shocks, falls and humidity should be avoided. Protect the cooling holes for transportation.

The weight of the electric machine can be found on the machine rating plate, and in the product data sheet.





### Receiving and unpacking





	<b>Do not touch the electric machine during the insulation resistance check. Discharge the electric machine afterwards.</b>
	<b>Do not touch the electrical terminals when the rotor is rotated. The electrical terminals have dangerous voltage during rotation. Contact Danfoss representative if the rotor can not be rotated.</b>
	<b>Remove the transportation supports of the electric machine.</b>

#### ***Check upon arrival and unpacking***

- The electric machine and the package must be inspected immediately upon arrival. Make sure that the rating plate data in the cover letter complies with the purchase order. Any external damage (in shaft-ends, flanges, electrical interfaces and paint) must be photographed and reported immediately.
- It is recommended to measure the insulation resistance of the electric machine upon arrival, or before installing the electric machine. Reference value of 500 MΩ shall be exceeded in room temperature, otherwise contact Danfoss representative. Refer to Chapter *Insulation resistance test* on page 31.
- Remove any transportation supports and shaft locks and rotate the shaft. It is normal for the rotation of the shaft to be difficult.

### Lifting

	<b>Use correct, adequately dimensioned lifting devices and inspect them before lifting.</b>
	<b>Do not lift from the shaft of the electric machine!</b>
	<b>Do not apply any excess weight on the electric machine when lifting.</b>
	<b>Use correct lifting slings. Use correct position and angle of lifting.</b>

	<b>See the electric machine rating plate for weight information.</b>
	<b>Lift the electric machine using the correct lifting lugs/eyes only.</b>
	<b>Do not go under a lifted load.</b>
	<b>Lifting slings cannot touch the electric machine during the lifting.</b>

*Lifting lugs/eyes/points for lifting slings and lifting position of the electric machine*

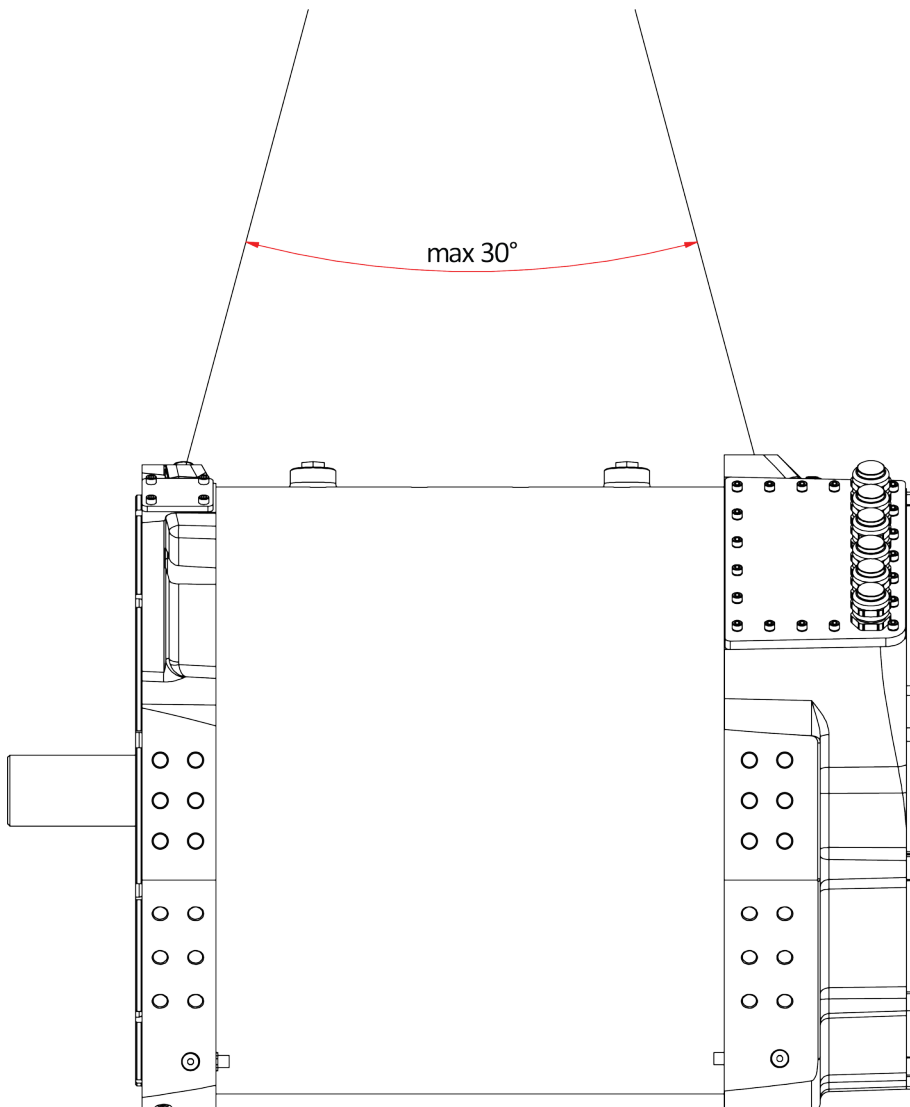



Lifting eye type: e.g. RUD VLBG-Plus-2t M16 (2 pcs)

**Horizontal lifting**

Install 2 pieces of lifting eyes to the lifting bores in the electric machine frame. The lifting eyes should be mounted with their full threaded length.

## Storage

	<p><b>Do not touch the electrical terminals when the shaft is rotated. The electrical terminals have dangerous voltage during rotation.</b></p>
	<p><b>Keep the electric machine on a correct base. Support the electric machine to prevent accidental turning and falling.</b></p>

- Always store the electric machine indoors. Storage temperature must be above -20°C and relative humidity less than 60 %.
- The storage should be dry, dust free and vibration free.
- Treat the unprotected electric machine surfaces such as the shaft-end and flanges against corrosion. Seal the cable exit holes and cooling bores for storage.
- The electric machine must not be subject to any external vibrations during storage to avoid damage to the bearings.
- To avoid water condensing in the electric machine, use anti-condensation heater(s), if fitted, or direct winding heating to keep the machine temperature above dew point.
- Rotate the shaft of the electric machine by hand monthly at least ten revolutions to prevent grease migration. If necessary use a tool such as a spanner. Do not damage the shaft in any case.

### Extended storage

Electric machines equipped with relubricable bearings: apply grease before and after long term storage.





It is recommended to inspect the electric machine in storage at periodic intervals. Use attached storage checklist.

Rotate the shaft of the electric machine once a month.

Keep the electric machine in its installation position while in storage. For example, vertically installed electric machines should be stored in vertical position.

## Installation

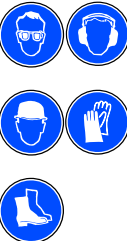
The following safety and information related symbols appear in this user guide and on the electric machine.



	<b>Risk of electric shock when the connection box is open. When you work with power connections make sure that electricity is disconnected and rotor rotation is prevented. Use isolated electric tools. Always ensure there is no voltage present at the power connections before working on the device by measuring the connections with a multimeter or voltage tester.</b>
	<b>Magnetic and electromagnetic fields generated near the current-carrying conductors and permanent magnets in electric machines represent a health danger to persons with heart pacemakers, metal implants and hearing aids. Persons with a heart pacemaker, metal implants or hearing aids must consult a doctor before they enter the following areas:</b> <ul style="list-style-type: none"> <li>• Areas in which electric equipment and parts are operated.</li> <li>• Areas in which electric equipment with permanent magnets are stored, mounted, operated or repaired.</li> </ul>
	<b>Only trained and qualified personnel familiar with the relevant safety requirements can work with the electric machine.</b>
	<b>Use correct personal protective equipment when you are near the electric machine.</b>
	<b>Read the instructions in this user guide before you install the electric machine.</b>

## Required tools

Following tools are required to install the electric machine:

- Grease pump.
- Ratchet torque wrench.
- Hex head wrench kit with different metric sizes.
- Socket wrench kit with different metric sizes.
- Cable gland tightening tool. Size according to cable glands.
- Cable skinning knife.
- Crimping tool for cable lugs. Consult cable lug manufacturer for correct size and crimping.
- Lifting slings with sufficient rated capacity.
- Lifting eyes. Size according to machine type. See Chapter *Lifting* on page 28.

## Insulation resistance test

	<b>Before performing the insulation resistance measurement, disconnect all cables and connectors from the electric machine under test.</b>
	<b>Do not touch the electric machine during the insulation resistance check. Discharge the electric machine afterwards.</b>
	<b>Measure the insulation resistance of the electric machine before and after the installation of the electric machine.</b>

Measure the insulation resistance of the electric machine before and after the installation of the electric machine. Because of the structure of the electric machine, it is possible that the stator is damaged during the installation.

Reference value of 500 M $\Omega$  has to be exceeded at reference ambient temperature 25°C (measured with 500 V<sub>DC</sub> / 1 min insulation resistance test). Contact Danfoss Editron service if the reference value is not exceeded.

### Measuring the insulation resistance



**Insulation resistance testers generate lethal voltages. Only qualified personnel should perform insulation resistance measurements.**

The insulation resistance is measured between motor terminals and the frame. When measuring the windings, the auxiliary circuits and other windings are grounded. When measuring the auxiliary circuits, all windings are grounded.

#### Dual winding motors - Winding 1

Test voltage	Test duration	Pass criteria
500 V <sub>DC</sub>	60 s	> 500 M $\Omega$

Measurement procedure:

1. Connect winding 2 phases to the motor frame.
2. Connect all pins of the LV connector, bearing temperature sensors and heaters to the motor frame.
3. Connect the measurement devices ground cable to the motor frame.
4. Connect the measurement probe to the winding 1 phases.

#### Dual winding motors - Winding 2

Test voltage	Test duration	Pass criteria
500 V <sub>DC</sub>	60 s	> 500 M $\Omega$

Measurement procedure:

1. Connect winding 1 phases to the motor frame.
2. Connect all pins of the LV connector, bearing temperature sensors and heaters to the motor frame.
3. Connect the measurement devices ground cable to the motor frame.
4. Connect the measurement probe to the winding 2 phases.

### Dual winding motor

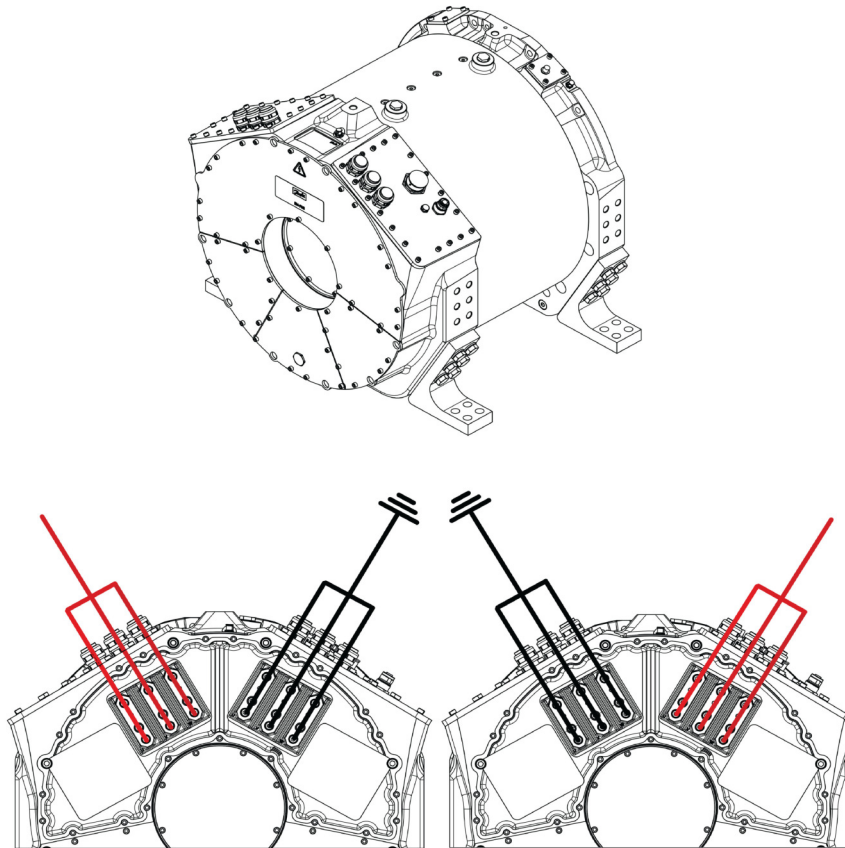

### Quad winding motors

For quad winding motors, repeat the measurement procedure given above for windings 1 and 2, but in addition connect windings 3 and 4 to the motor frame before making the measurements. Then proceed to the following measurement steps for windings 3 and 4.

#### Quad winding motors - Winding 3

Test voltage	Test duration	Pass criteria
500 V <sub>DC</sub>	60 s	> 500 MΩ

Measurement procedure:

1. Connect winding 1, 2 and 4 phases to the motor frame.
2. Connect all pins of the LV connector, bearing temperature sensors and heaters to the motor frame.
3. Connect the measurement devices ground cable to the motor frame.
4. Connect the measurement probe to the winding 3 phases.

#### Quad winding motors - Winding 4

Test voltage	Test duration	Pass criteria
500 V <sub>DC</sub>	60 s	> 500 MΩ

Measurement procedure:

1. Connect winding 1, 2 and 3 phases to the motor frame.
2. Connect all pins of the LV connector, bearing temperature sensors and heaters to the motor frame.
3. Connect the measurement devices ground cable to the motor frame.
4. Connect the measurement probe to the winding 4 phases.

## Quad winding motors

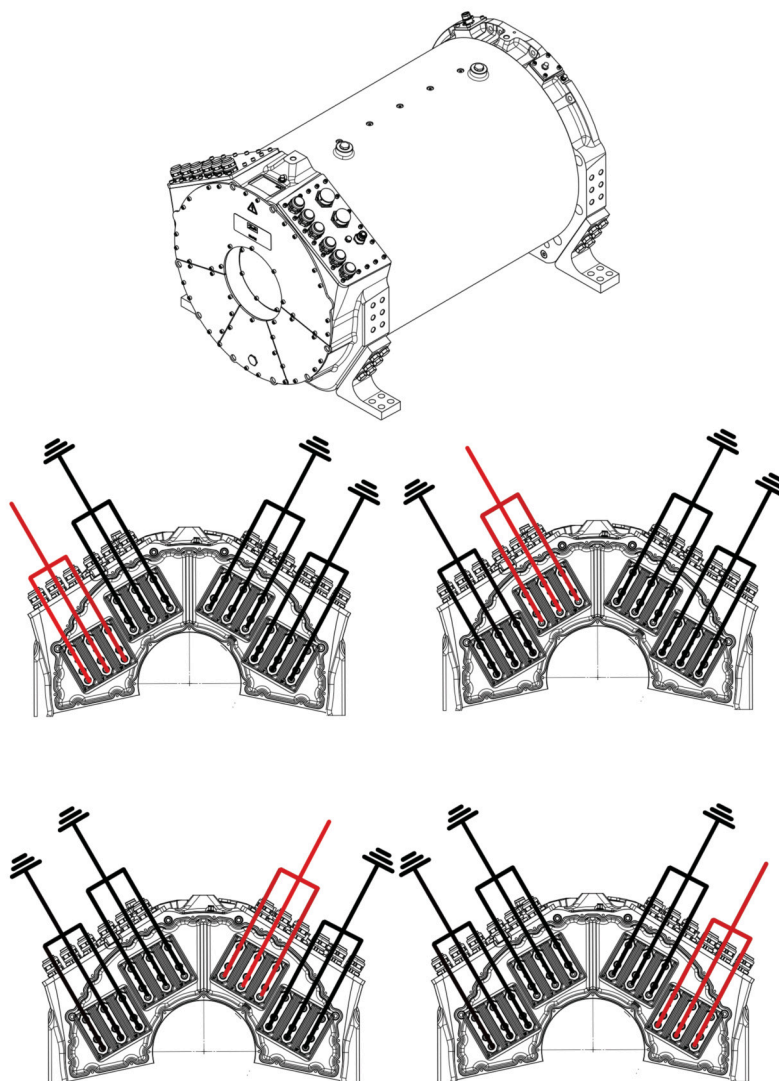

## Auxiliary circuits

Test voltage	Test duration	Pass criteria
500 V <sub>DC</sub>	60 s	> 500 MΩ

Measurement procedure:

1. Connect all winding phases to the motor frame.
2. Connect all auxiliary circuits together by using counter connectors, but see exemptions below:
  - a. For LV connector Deutsch HD34-24-47PE, do not connect grounding pins 1, 4, 5, 6 and 34.
  - b. For heater connector Hummel Twinlock, do not connect grounding pin 3.
  - c. PMI540B-T1500/T2000: For LV connection box, do not connect pin 35 and grounding pins.
  - d. PMI540B-T3000/T4000: For LV connection box, do not connect grounding pins.
3. Connect the measurement device ground to the motor frame.
4. Connect the measurement probe to all auxiliary circuits.

*Auxiliary circuit measurement - Dual winding motor*

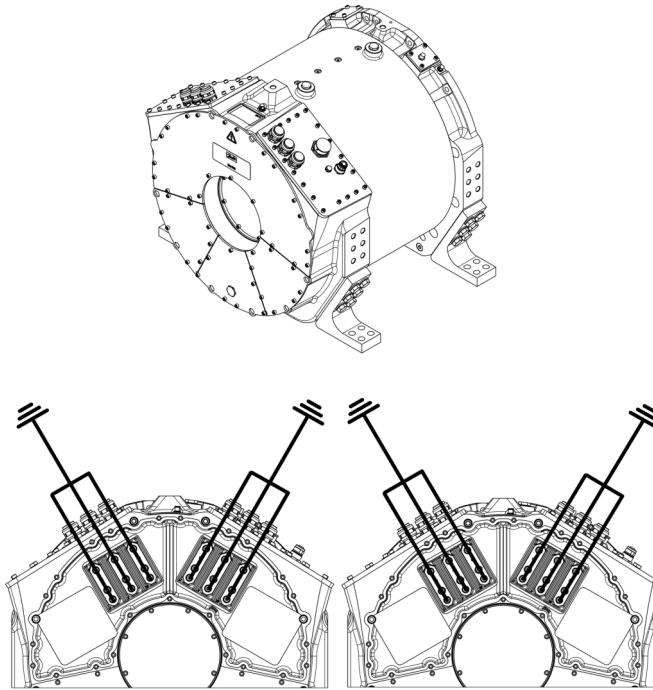

*Auxiliary circuit measurement - Quad winding motor*

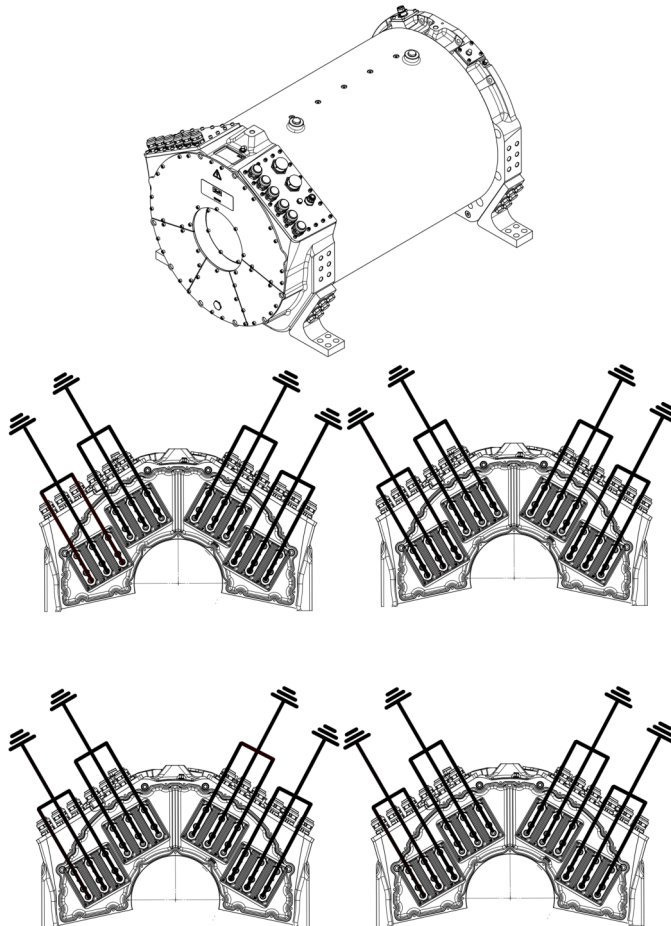

## Mechanical installation

### Allowed mounting positions





It is in some cases possible to make an exception from the limitations of the mounting positions. Document *Allowed bearing loads for EM-PMI machines DOC-000454* gives more information about this. Contact Danfoss to obtain the document.

If the application is a moving work machine or similar, it is allowed to deviate from the allowed mounting position for the duration of 30 % of the work cycle. This applies to electric machines with grease lubricated bearings.

The electric machine must be installed horizontally. The standard horizontal mounting option (MDH) is the only possible mounting option. When mounting, the electric machine can be turned around its axis (shaft) for maximum of  $45^\circ$  both directions from its default installation direction. Along the axis, the tilt angle may be maximum of  $10^\circ$  both directions. See Figure below.

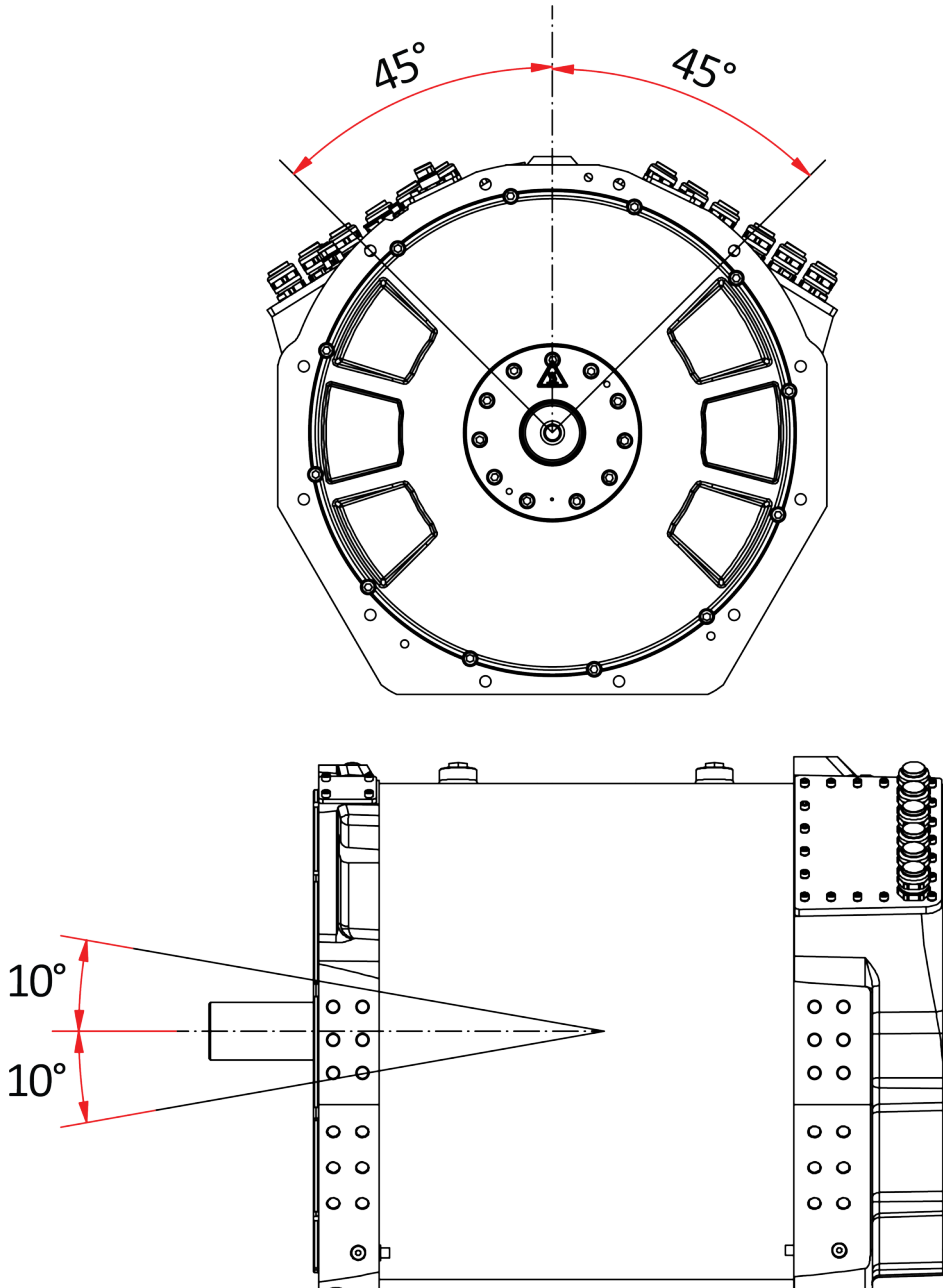
*Allowed mounting position*



Line type	Meaning
	Allowed machine tilt angle for continuous operation. (viewed from the shaft end)
	Allowed momentary machine tilt angle, for the maximum duration of 30 % of the work cycle. (viewed from the shaft end)

Allowed machine tilt angle during operation

### EM-PMI540B-T1500, -T2000

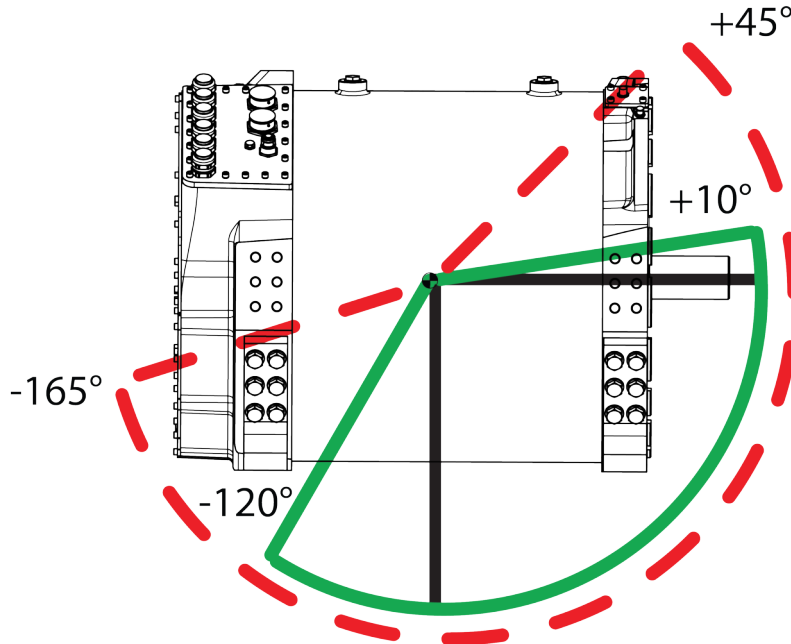

### EM-PMI540B-T3000, -T4000

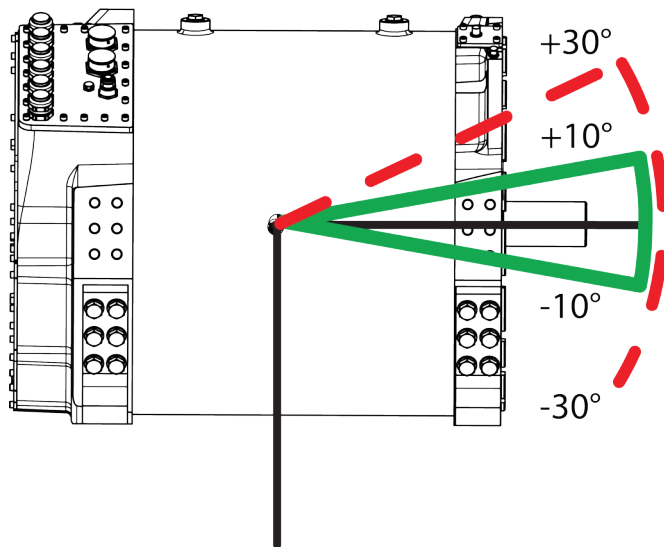

### Mounting the electric machine



**Do not exceed the maximum axial and radial forces calculated for the shaft. Document Allowed bearing loads for EM-PMI machines DOC-000454 gives more information about this. Contact Danfoss to obtain the document.**



**Do not use the N-end of the electric machine for mounting the electric machine.**



**Refer to Chapter *Allowed mounting positions* for the correct mounting positions of the electric machine.**

Mount the electric machine on a correct supporting structure as discussed in Chapter *Supporting structure requirements*.

### **Horizontal assembly**

1. Lift the electric machine to the correct mounting position. See Chapter *Lifting* for details.
2. The electric machine is mounted from its D-end flange (SAE1/2 transmission housing flange). SAE1/2 flywheel housing is required as a mating flange. If additional support is needed, use the Side/Foot/V-mounting bores.

Note that V-mounting is not applicable to the EM-PMI540B-T4000 variant, and the highlighted mounting is used only for Foot mounting.

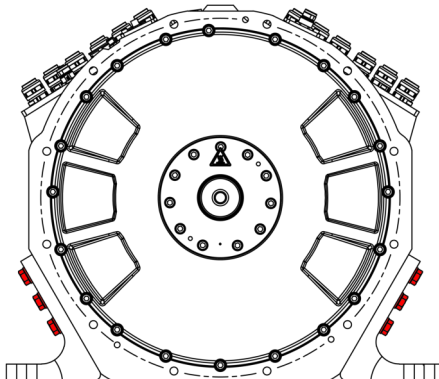
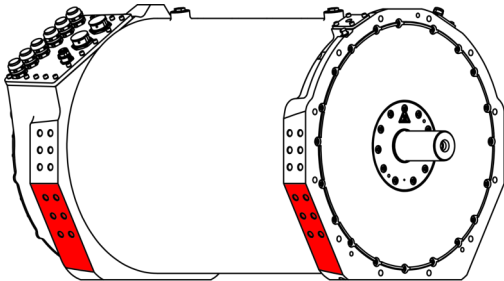

3. Align the electric machine with the mating housing alignment. See Chapter *Shaft alignment and load*.
4. Connect electric machine shaft, ensuring full spline engagement. Lubricate the spline. *Before* connecting the shaft, ensure the splines are clean and free of protective wax to prevent lubricant contamination.

The recommended spline lubricant is a 50/50 mixture of high-temperature grease and molybdenum disulfide powder. Apply initially and reapply regularly to prevent fretting corrosion and premature wear. This lubricant is oil-insoluble. Suitable alternatives include Molycote, Metaflux, Never-Seez, and Optimol.

5. Attach the mounting bolts. For steel housing the minimum length of the bolt is 40 mm and for aluminum housing 45 mm. Refer to Chapter *Tightening torques* on page 20 for the correct tightening torques.

*Mechanical mounting connections of the electric machine (horizontal mounting)*

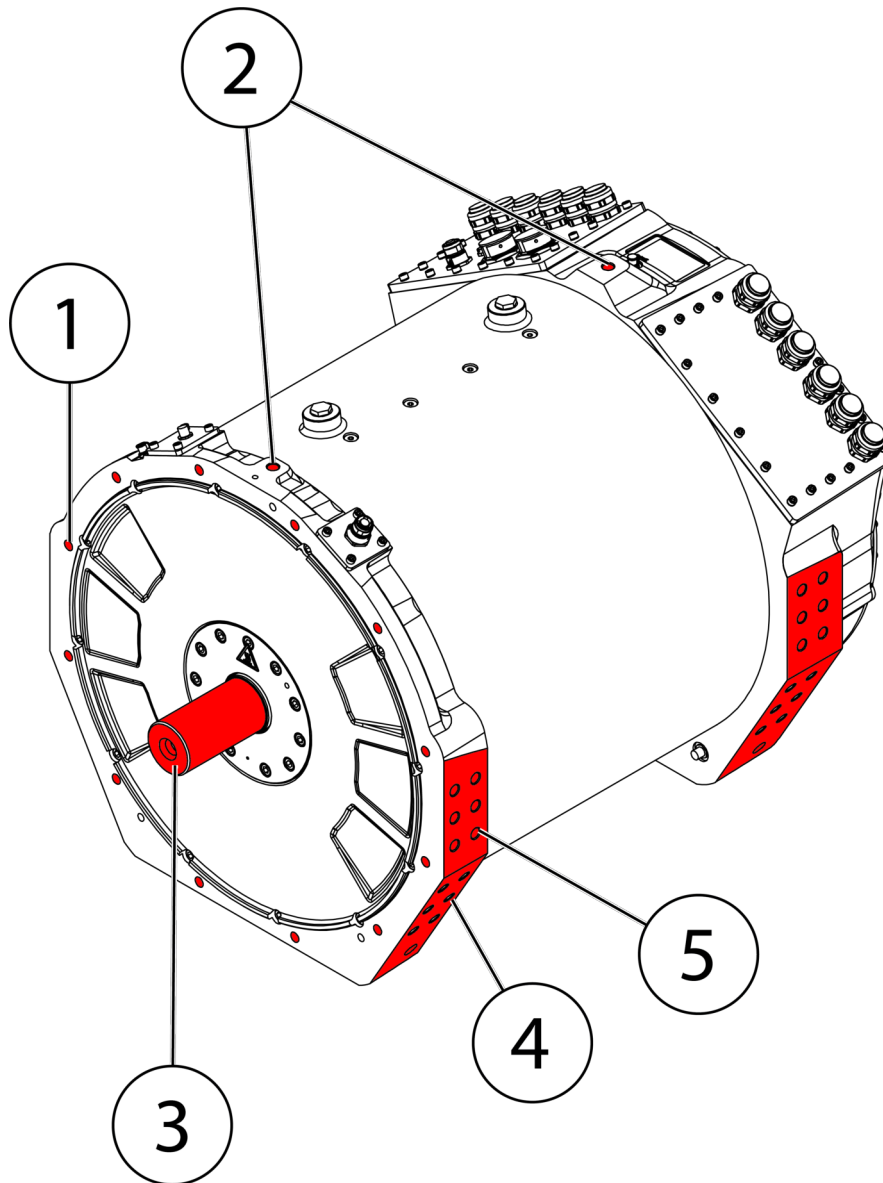

1	D-end flange (SAE1/2) and bolt bores for mounting the electric machine (12 pieces).
2	Bores for the lifting eyes.
3	Shaft of the electric machine: EM-PMI540B-T1500/T2000: W55x2x26x8f EM-PMI540B-T3000/T4000: Cylindrical shaft, dia:70 mm h7, contact length130 mm
4	Foot / V- mounting bores.
5	Side mounting bores.

**Vertical assembly**

In vertical assembly, follow the Steps given in the previous Section *Horizontal assembly*.

**Cooling connections**

Connect the electric machine properly to the cooling circuit. Make sure that the coolant flow is equal or higher than rated and the coolant temperature at the inlet of the machine cooling is lower or equal to the rated temperature. For more

information, see Chapter *Recommended coolants* and product data sheet. Rated values can be found in the electric machine rating plate.

Make sure that cooling liquid runs freely into and out from the electric machine.

When selecting cooling liquid nipples, choose nipples that can resist galvanic corrosion.

To prevent damage to the cooling connectors, refer to the documentation of the manufacturer for the correct tightening torque of the cooling liquid nipples.

Aluminum frame water-cooled construction is only to be used with a closed fresh water circulation with corrosive inhibitor described in the data sheet. The water cooling circuit connection is described in the data sheet. Use only suitable and high-class connection parts and seals to connect the electric machine to the water circuit. Check for possible leaks after the piping and joints have been connected.



It is recommended to use coolant connector equipped with o-ring seal or to use sealing washer (for example Usit or Bonded seals) in the connection. In addition, it is recommended to use thread sealant (Loctite 577 or similar) at the coolant connections to prevent loosening. Loosening can be caused by vibration or temperature variations.

The electric machines are equipped with at least three PT100 temperature sensors in the windings. The amount of the sensors depend on the options chosen. The temperature signal(s) can be read out from the measurement connector of the machine.

## Electrical installation

### Power connections

#### *High voltage connection*

	<b>Risk of electric shock when connection box is open. When you work with power connections make sure that electricity is disconnected and shaft rotation is prevented. Always ensure there is no voltage present at the power connections before working on the device by measuring the connections with a multimeter or voltage tester.</b>
	<b>Make sure the power cables exit straight from the terminals and do not rub against the sharp cable through-holes or other sharp edges which could wear out the cable insulation over time.</b>
	<b>Do not place any excess weight on the connection box lid(s).</b>

The high voltage cables of the electric machine are connected to the connection box(es) of the electric machine. The figure below shows the components of the high voltage connection box assembly.

You are allowed to open only the nuts and bolts that are specified here. Only Danfoss professionals are allowed to open other nuts and bolts in the terminal box.

#### **Installing the power cables:**

1. Remove the cover of the terminal box.
2. Install the power cables.
  - a. Remove the cable lug attachment nut/bolt and washers.
  - b. Place the cable lug against the busbar.
  - c. Place flat washer on top of the cable lug and spring washer on top of the flat washer.
  - d. Screw on the nut/bolt and tighten. Refer to Section *Tightening torques* on page 20 for the correct torque.
3. Install the cover of the terminal box back.

When installing the connection box lid, ensure that the mating surfaces are clean and free of any foreign particles. Verify that all connection box fasteners are present and properly tightened. Missing or loose fasteners can compromise the insulation and create a safety hazard.

For more information on how to install the power cables, see especially steps 8-13 in *Cable gland assembly and power line connection* on page 46.

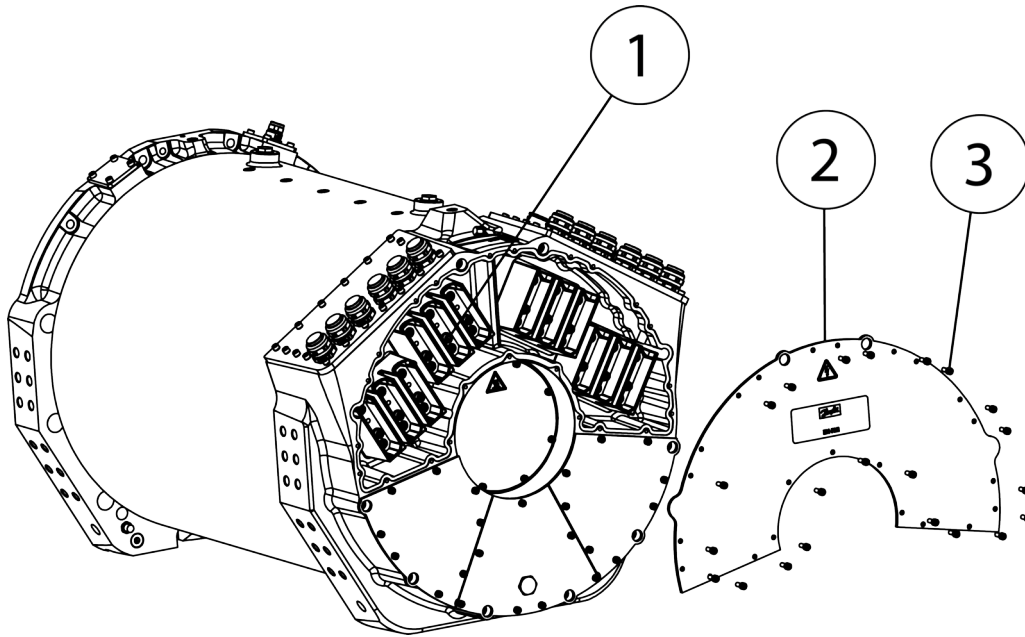
*High voltage connection assembly structure*

1	Connection box module
2	Connection box cover plate, gasket extruding
3	Connection box mounting bolts, M6 x 16

See the numbering of the winding systems in the figure below.

*DUAL and QUAD winding motors*

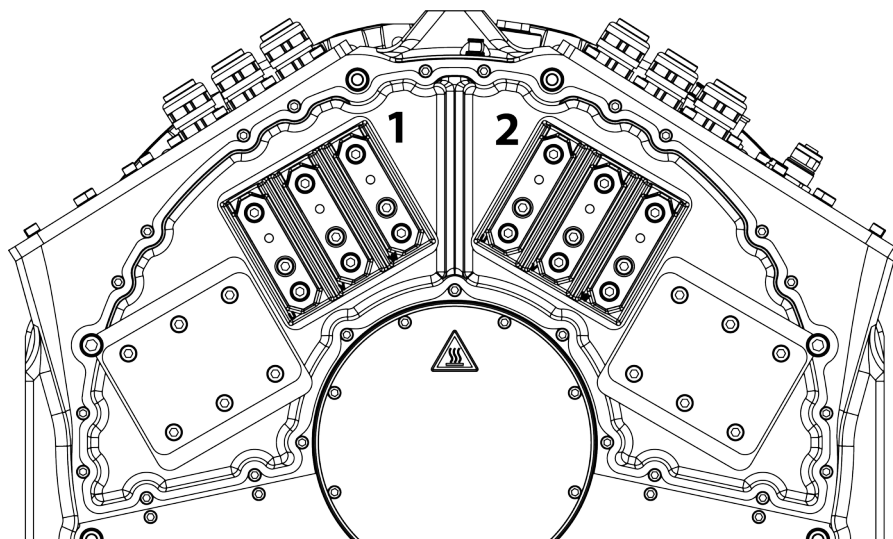

**DUAL**

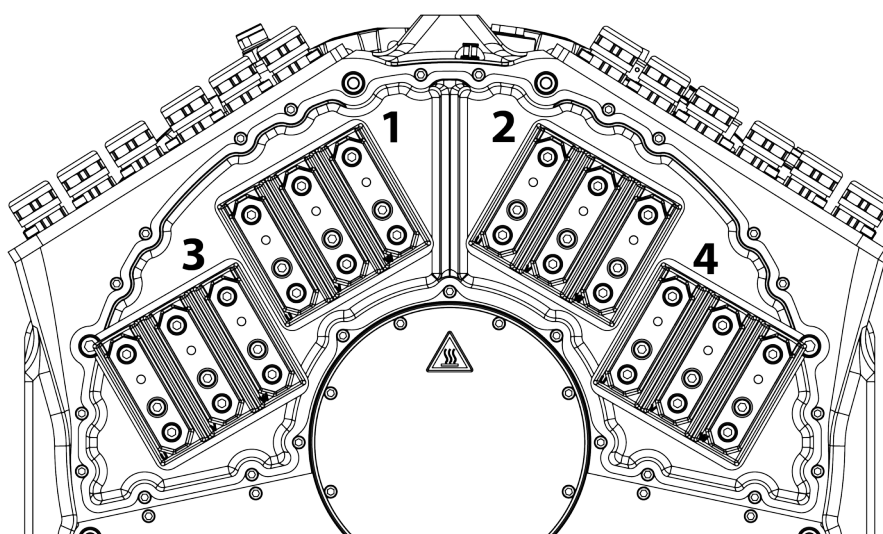

**QUAD**

All connection box modules have the same phase order as shown in the following figure.

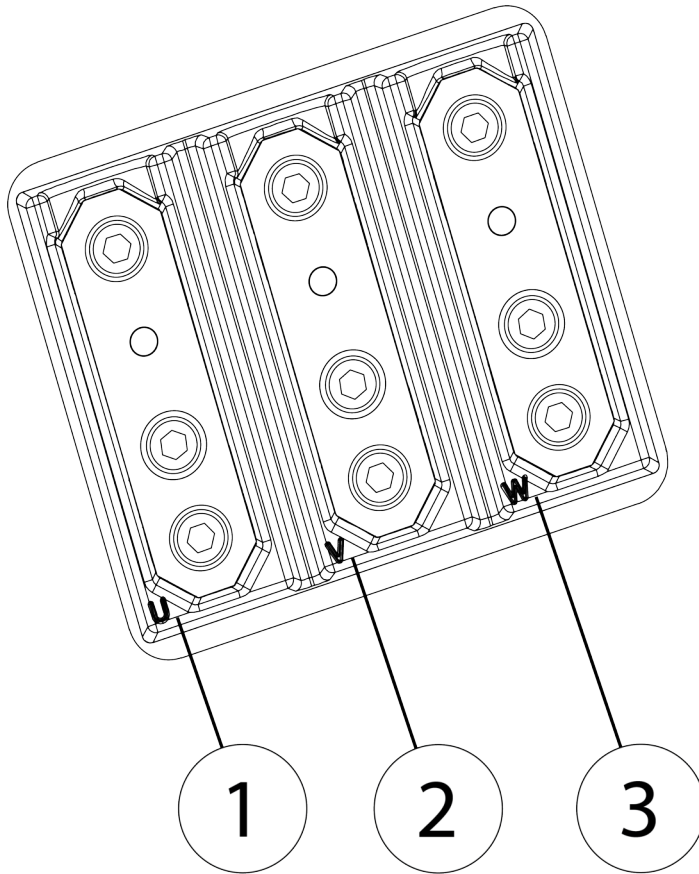
*Winding phases in connection box modules*

Connection	Phase
1	U / L1
2	V / L2
3	W / L3

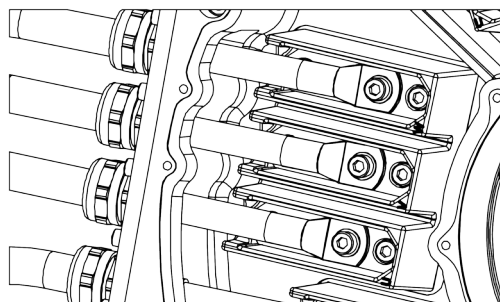
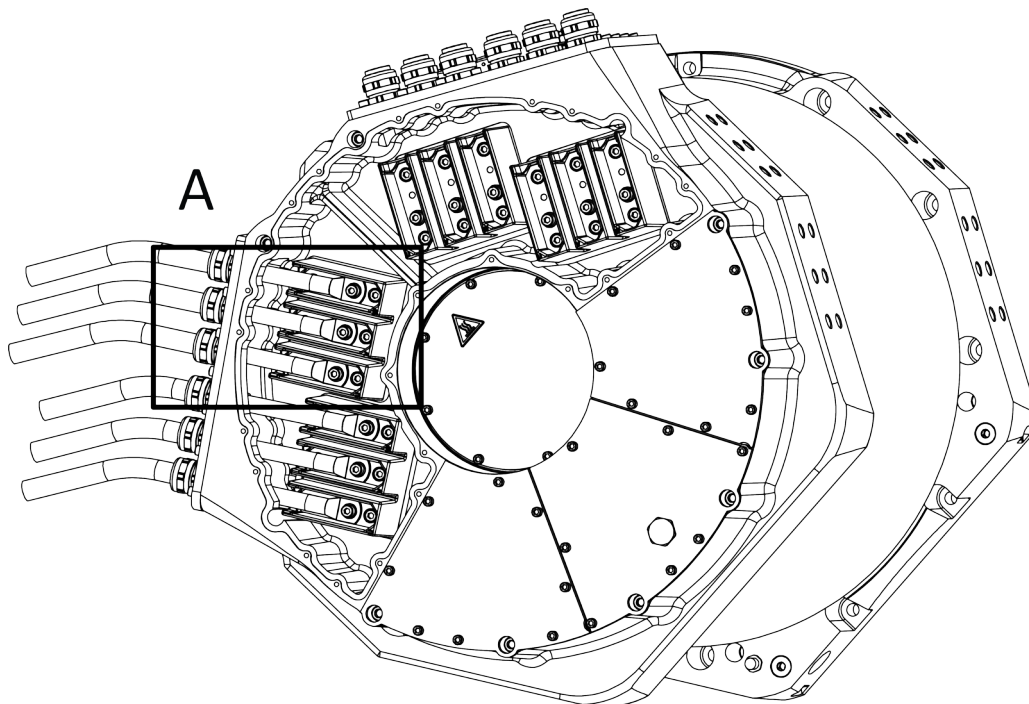
*Inside view of the machine connection box*

**A (1:5)**

Leave the connection box cover plate open for further electrical assembly as instructed in Chapter *Cable gland assembly and power line connection* on page 46.

**Connection diagram**

The electric machines are intended to be powered and controlled by three-phase alternating current, supplied by an inverter or inverters. The electric machine is not suitable for direct online use.

The amount of inverters depends on the electric machine and converter current ratings. See also the relevant wiring diagrams.

For an electric machine with option DUAL (two connection boxes each containing one three-phase system), the electrical connection principles from the inverters are shown in the figure below.

Connection diagram for DUAL option

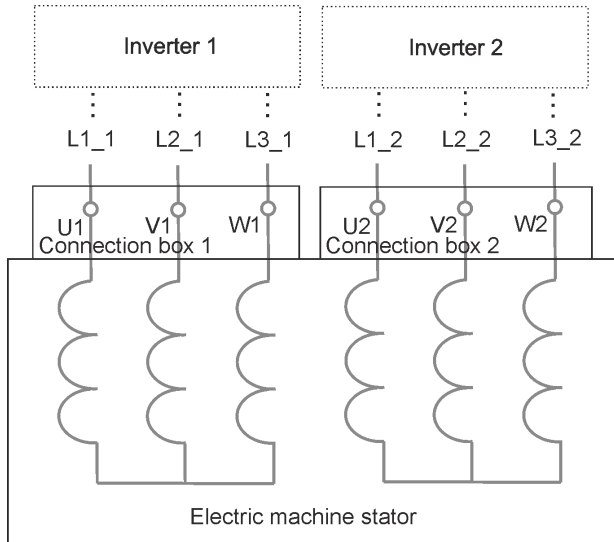

For an electric machine with option QUAD (four galvanically isolated three-phase systems), the electrical connection principles from the inverters are shown in the figure below.

Connection diagram for QUAD option

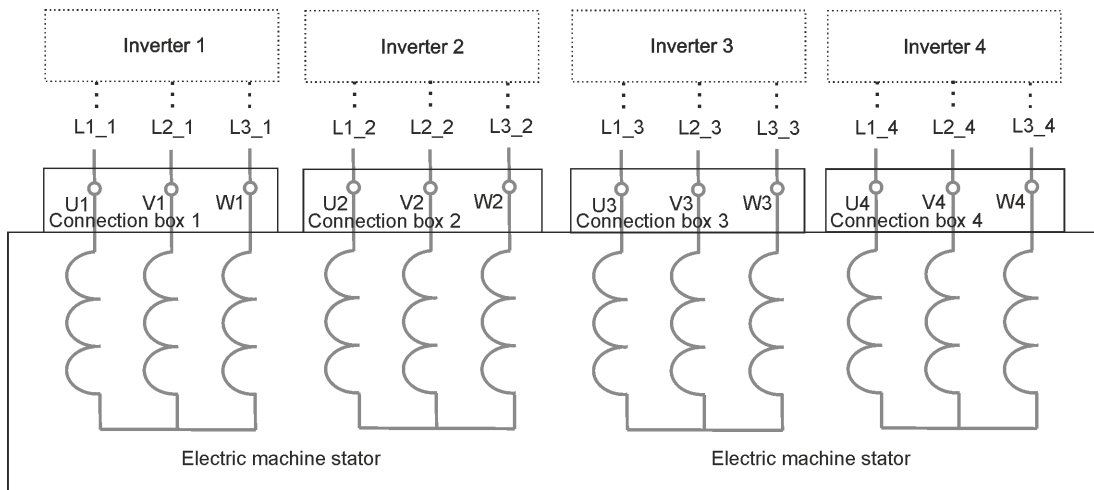

Ensure correct phase sequence at the connection box when connecting two inverters to an electric machine with QUAD option.

Incorrect phase order can cause the two inverters to work against each other preventing the proper operation of the machine.

For single-inverter operation of a DUAL or QUAD electric machine, the phase cables must be connected in parallel as shown in the figures below. Incorrect phase sequencing during parallel connection will result in improper operation and risk of machine damage.

*DUAL with a single inverter*

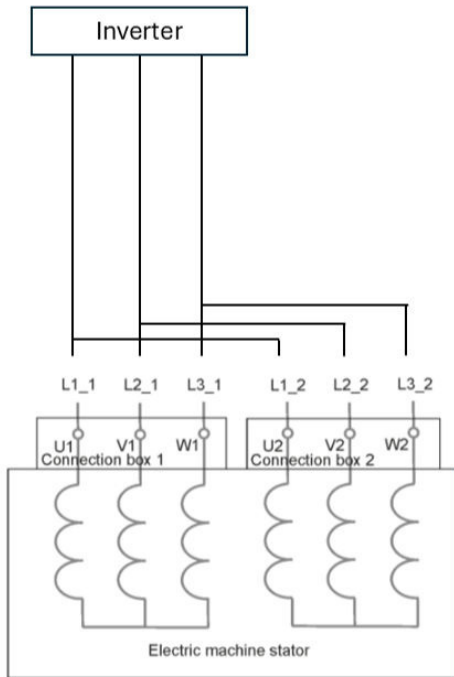

*QUAD with a single inverter*

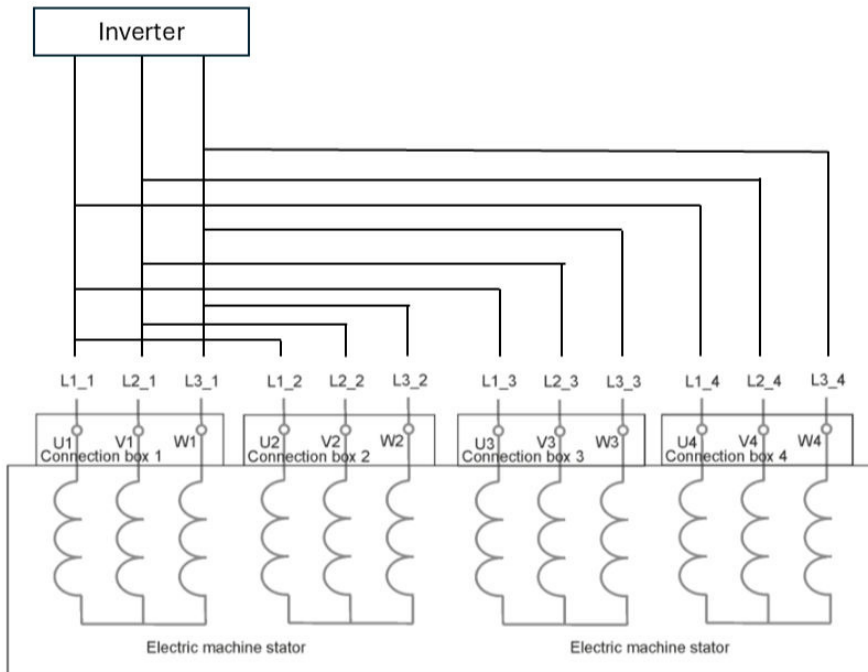

**Cable gland assembly and power line connection**



**If you are not using the recommended cable lugs, select cable lugs that leave 10 mm gap between each and every cable lug on the same connection plate.**

This Chapter describes how to assemble screened power cables to the electric machine. See the cable glands recommendations from the Table below. Cable gland assembly instruction can also be found from PFLITSCH gland catalog available from <http://www.pflitsch.de>.

Use correct type of gland for different cable diameters. These are shown in the Table below.

#### Cable gland alternatives

Cable gland	Cable cross sectional area (*)	Thread	Max. cable Ø	Max. shield Ø
Pflitsch bg 225ms tri	35 mm <sup>2</sup> 50 mm <sup>2</sup> 70 mm <sup>2</sup>	M25 x 1.5, 7.5 mm	20 mm	16 mm
Pflitsch bg 232ms tri	70 mm <sup>2</sup> 95 mm <sup>2</sup> 120 mm <sup>2</sup>	M32 x 1.5, 8.0 mm	25 mm	20 mm

(\* Applicable with the recommended cable type (HUBER+SUHNER Radox Elastomer S))

#### BlueGlobe cable gland tightening torques

Metric thread	Nominal torque
M10 x 1.0	3.0 Nm
M12 x 1.5	5.0 Nm
M16 x 1.5	8.0 Nm
M20 x 1.5	10.0 Nm
M25 x 1.5	15.0 Nm
M32 x 1.5	15.0 Nm
M40 x 1.5	20.0 Nm
M50 x 1.5	30.0 Nm
M63 x 1.5	35.0 Nm
M75 x 1.5	80.0 Nm
M85 x 2.0	100.0 Nm

The pictures are schematic, and the actual components can look different.

1. Remove the small hexagonal piece from the BlueGlobe-sealing insert as shown in Figure below.

#### BlueGlobe-sealing

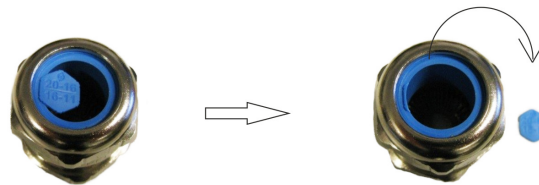

2. Cut the cable sheath at the distance A from the end of the cable, see Figure below. Pull the cut part of the sheath partly (length B is from 10 to 15 mm) off the cable as shown in the Figure. The distance A depends of the length of the cable lug used. Measure with the cable lug that is used and cut to suitable length.



**Do not remove the cable sheath completely at this point and do not cut the braid screen of the cable!**

*Cut length of the cable sheath*

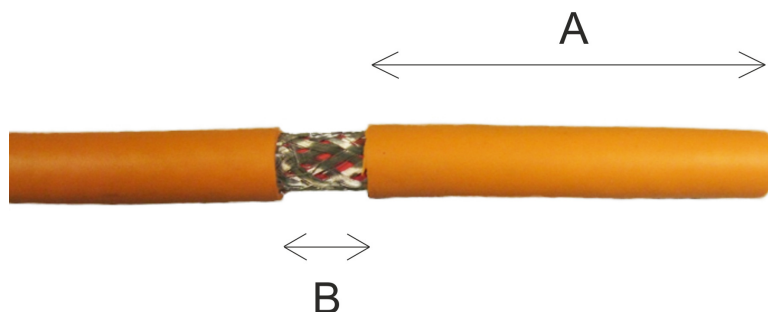

- 3.** Wrap two layers of copper tape on the cable so that the distance B is covered. Use 3M™ Copper Foil Tape 1181 or similar. Contrary to the image below and depending on the cable and the cable gland size, you can leave the length A sheath in place for the next step to help the placement of the cable gland and remove the sheath only after the next step.

*Cover the cable with copper tape*

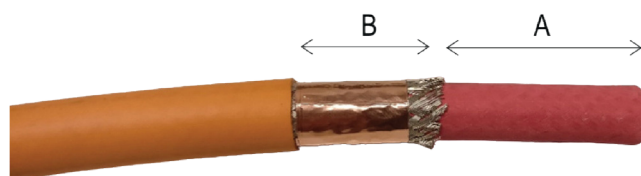

- 4.** Insert the cable to the cable gland with slight turning motion. This helps the cable to go through the spring inside the cable gland. Push the cable gland against the sheath of the cable as shown in Figure below.

*Cable to the gland assembly*



- 5.** After the cable gland is in place remove the length A piece of the sheath and cut the braid screen (cover) from 10 mm (distance C) from the gland bottom as shown in Figure below. *Before cutting the braid screen, verify that the cable gland spring is correctly positioned against the cable sheath, which must be protected with copper tape.*

*Cut the braid screen*

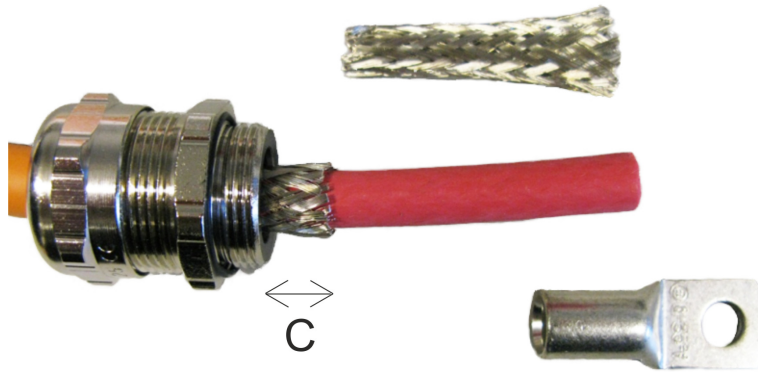

6. Cut a piece of length D of the inner sheath shown below in the Figure *Cutting the inner sheath*. The length D must equal to the length of the cable lug body.

*Cutting the inner sheath*

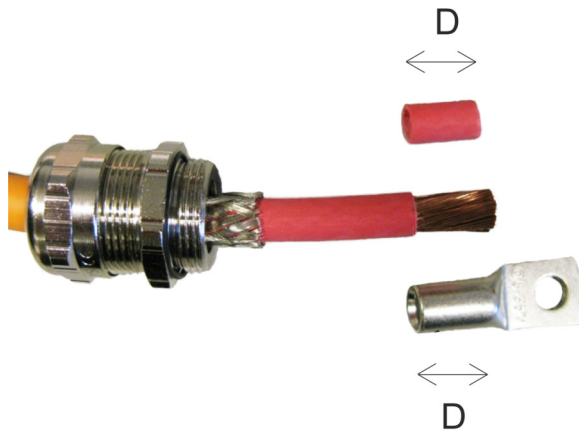

7. a) Make sure that the conducting strands of the cable are completely free of silicone and other impurities. Insert cable conductors fully into cable lug. Make sure that the cable lug is not too loose and that all conductors fit inside the lug. If not, check from the part list that you are using the correct cable lugs.
- b) Always use the crimping tool of the cable lug manufacturer. Before crimping, check the cable lug size from the lug (e.g. 35-8 is 35 mm<sup>2</sup>) and select the same size dies for the crimping tool. Use hexagonal dies.
- c) Crimp the cable lug at least twice in different places starting as near to the flat part of the lug as possible and towards the barrel part of the lug. Make sure that the cable does not slip out from the lug while crimping.
- d) Remove any excess compound emerging from the sides of the cable lugs after the crimping. Verify that the cable lug is evenly compressed with clear hexagonal crimps and that no conductors are broken. See Figure below.

### Connecting cable lug



8. Cut piece of shrink tube and shrink it over the cable lug and braid screen as shown in Figure below. This is done to keep the braid screen in place and for extra insulation. Use shrink tube rated for -40°C to 150°C. Self-gluing type is recommended.

### Shrink tube



9. Insert the cable through the corresponding hole in the connection box and connect the cable lug to the connection point. Use spring washer between the cable lug and the connection screw or nut. Do not tighten the connection at this point to ensure fitting of the cable gland.

Ensure a minimum 10 mm air gap between the cable lug and other metallic structures including the braid of the cable. If the air gap is smaller, use extra insulation shrink tube to cover the lug.

Cable lug connection to the connection box (example only, the connection box may look different)

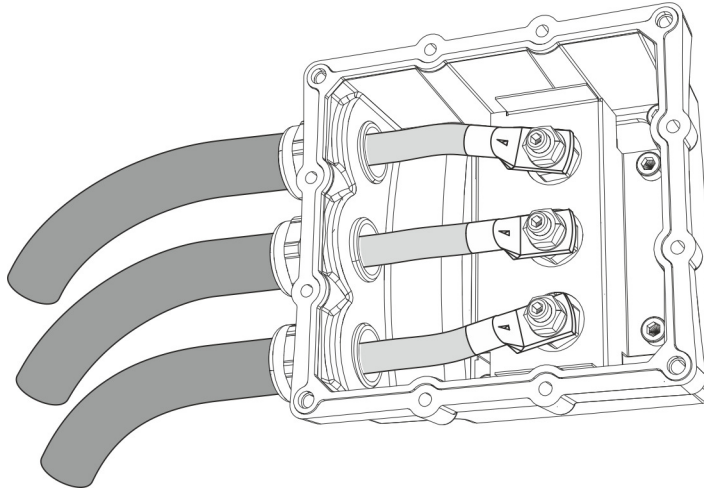

10. Screw the cable gland to the connection box as shown in the Figure above.



**Tighten the cable gland from the cable gland body to enclosure. Refer to *Tightening torques* on page 20 for the correct torque. Then tighten the cap of the cable gland according to the instructions provided by cable gland manufacturer (recommendation Pflitsch).**

11. Tighten the cable lug. Refer to *Tightening torques* on page 20 for the correct torque.

12. Repeat the procedure to the other cables and connection boxes.

13. Check that the phase connections order in the connection box is correct, that is, the corresponding phases between the inverter and the machine are connected (U, V, W correspond to the L1, L2, L3 phases).

14. Close the connection box. Tighten the connection box cover screws. See Chapter *Tightening torques*. Use thread locking compound that makes it possible to remove the screws. (For example Loctite 221).

If you must connect the anti-condensation heater, you can leave the connection box open. See Chapter *Anti-condensation heater connections* on page 69.

15. Check the power cable shield grounding, see Chapter *Grounding connections*.

*Cable lug and cable gland assembly cross section*

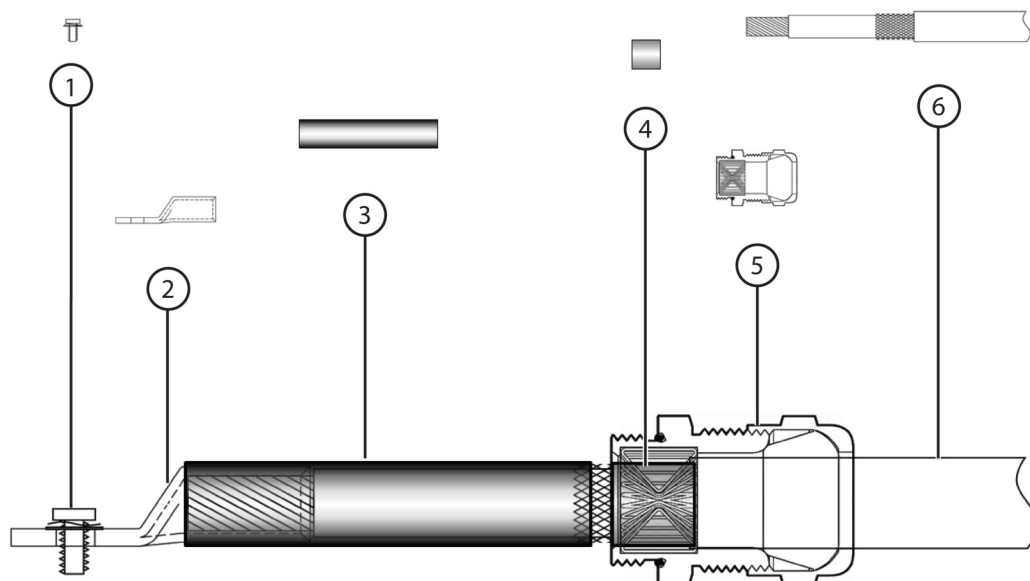

1	Cable lug bolt or nut with washers (depending on the electric machine)
2	Cable lug
3	Shrink wrap
4	Copper tape

5	Cable gland
6	Cable

### Low voltage connections



The electric machine uses a low voltage connector or, optionally, a low voltage connection box (+LVB1).

The electric machine has a connector or a connection box which is used to read out inbuilt temperature and rotation sensor (resolver) data from the electric machine. The temperature data comes from PT100 sensors in the stator windings and in some cases in the bearings. The rating plate has the information about the options of the electric machine: different options add sensors, and some electric machines do not have all the sensors. For more information about the options, refer to Chapter *Product naming convention* on page 5.

Ensure all unused socket holes of the low voltage connector are plugged with suitable plugs:

- DEUTSCH 0413-003-1605 (size 16)
- DEUTSCH 0413-204-2005 (size 20)

For more information and instructions contact the connector manufacturer directly at <https://www.deutschconnector.com/>.

#### Recommended cable types for low voltage connections

Application	Cable type
Resolver cabling	Shielded cable (twisted pair)
Temperature measurement (PT100)	Shielded cable (twisted pair)

#### Location of the low voltage connectors in the connection box

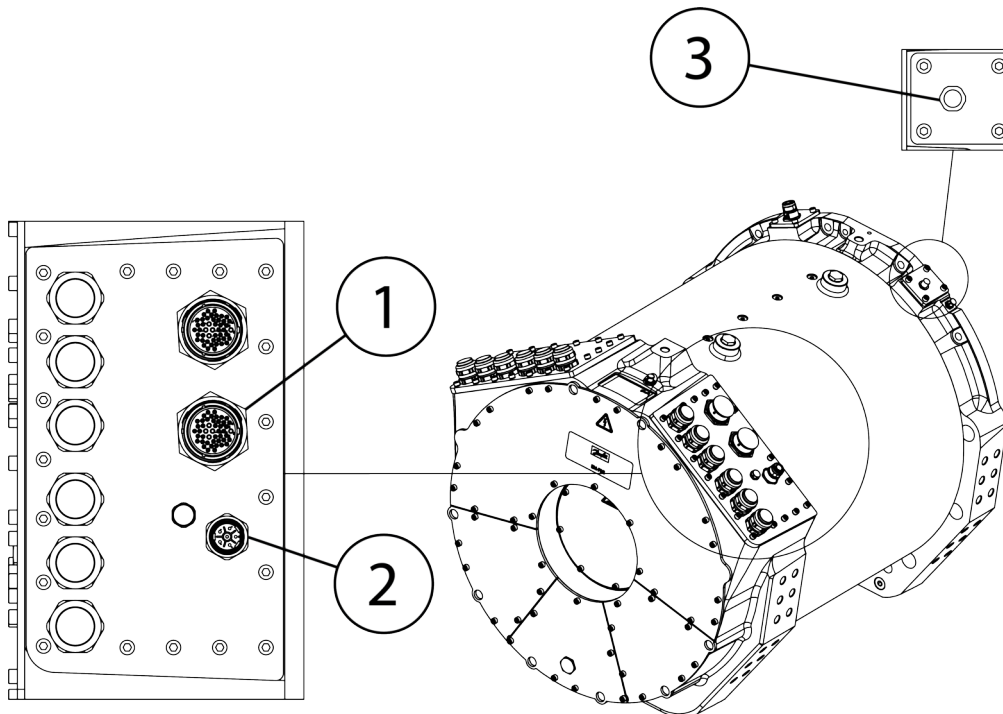

1	Low voltage connector: - Winding temperature sensors and resolver connections - Bearing temperature measurement sensor connector
2	Anti-condensation heater connector
3	Bearing temperature measurement connector

Low voltage connection box (+LVB1 option)

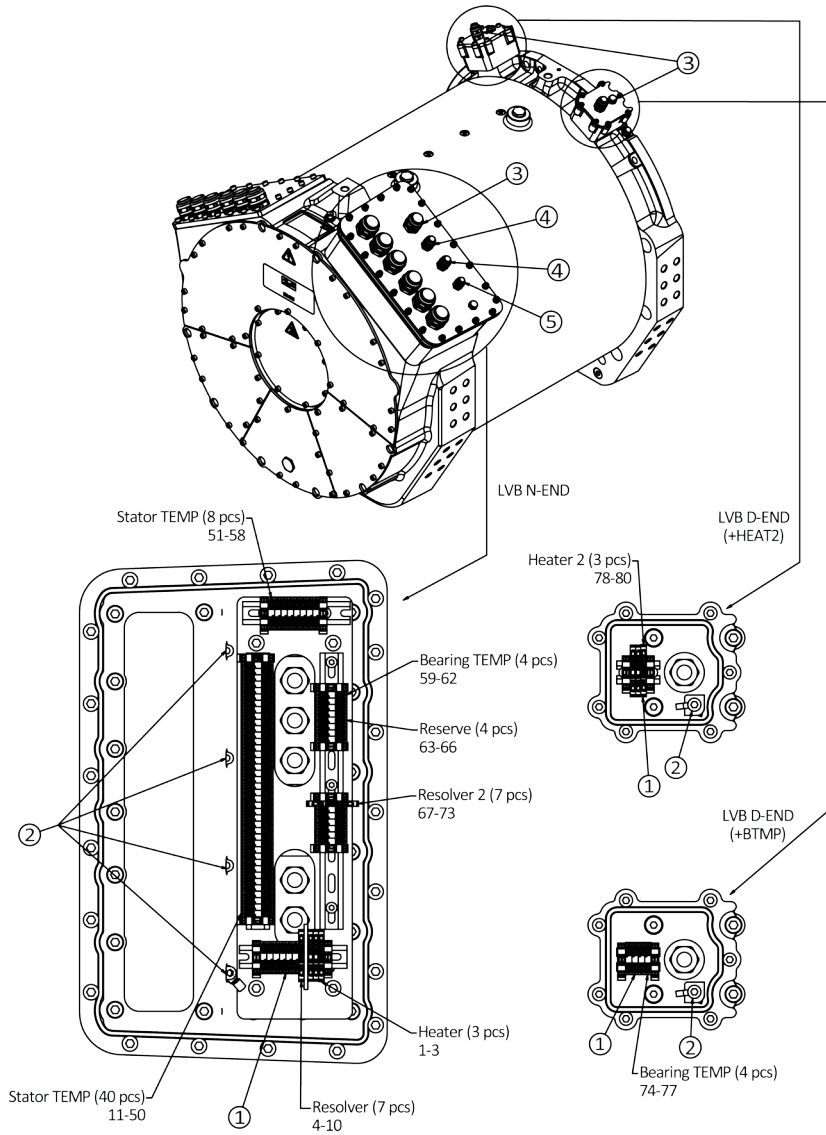

**LVB D-END (cover removed)**

1	Terminal block
2	Grounding connection (M5)
3	M16 cable gland

**LVB N-END (cover removed)**

1	Terminal block
2	Grounding connections (M5)
3	M25 cable gland
4	M16 cable glands
5	M12 cable gland

**Low voltage connector details**

	<b>Deutsch HD34-24-47PE connector has two kinds of mating pins: 1 mm and 1.5 mm in diameter.</b>
--	--

## Pin configuration of the Deutsch HD34-24-47PE connector

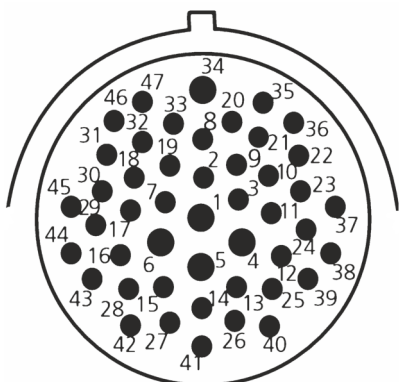

## Pin configuration of LV-connector for EM-PMI540B-T1500/T2000 (Applicable for machine variant with -DUAL high voltage connections)

Measurement	Description	PIN	Option
Temperature 1	phase U1, main sensor, PT100 (P)	47	
	phase U1, main sensor, PT100 (N)	46	
Temperature 2	phase V1, main sensor, PT100 (P)	33	
	phase V1, main sensor, PT100 (N)	32	
Temperature 3	phase W1, main sensor, PT100 (P)	45	
	phase W1, main sensor, PT100 (N)	31	
Temperature 4	phase U2, main sensor, PT100 (P)	30	
	phase U2, main sensor, PT100 (N)	29	
Temperature 5	phase V2, main sensor, PT100 (P)	44	
	phase V2, main sensor, PT100 (N)	43	
Temperature 6	phase W2, main sensor, PT100 (P)	28	
	phase W2, main sensor, PT100 (N)	16	
Temperature 7	phase U1, spare sensor, PT100 (P)	42	+TEMPS
	phase U1, spare sensor, PT100 (N)	27	
Temperature 8	phase V1, spare sensor, PT100 (P)	15	+TEMPS
	phase V1, spare sensor, PT100 (N)	14	
Temperature 9	phase W1, spare sensor, PT100 (P)	40	+TEMPS
	phase W1, spare sensor, PT100 (N)	26	
Temperature 10	phase U2, spare sensor, PT100 (P)	41	+TEMPS
	phase U2, spare sensor, PT100 (N)	13	
Temperature 11	phase V2, spare sensor, PT100 (P)	39	+TEMPS
	phase V2, spare sensor, PT100 (N)	38	
Temperature 12	phase W2, spare sensor, PT100 (P)	25	+TEMPS
	phase W2, spare sensor, PT100 (N)	12	
Resolver COS	Resolver, RES_COS_N, Inbuilt non-contacting	35	
Resolver COS	Resolver, RES_COS_P, Inbuilt non-contacting	20	
Resolver SIN	Resolver, RES_SIN_N, Inbuilt non-contacting	36	
Resolver SIN	Resolver, RES_SIN_P, Inbuilt non-contacting	21	
Resolver EXCN	Resolver, EXCN, Inbuilt non-contacting	22	
Resolver EXCP	Resolver, EXCP, Inbuilt non-contacting	10	
Resolver shield	Resolver, SHIELD/GROUND, Inbuilt non-contacting	34	
Reserve			
Reserve			
Reserve			

*Pin configuration of LV-connector for EM-PMI540B-T1500/T2000 (Applicable for machine variant with -DUAL high voltage connections) (continued)*

Measurement	Description	PIN	Option
Reserve			
Reserve			
Reserve			
Reserve			
Bearing temperature, sensor 1	PT100	2	
Bearing temperature, sensor 1	PT100_GND	18	
Bearing temperature, sensor 2	PT100	3	
Bearing temperature, sensor 2	PT100_GND	19	

*Pin configuration of LV-connector for EM-PMI540B-T3000/T4000 (+DUAL)*

Measurement	Description	PIN	Option
Temperature 1	phase U1, main sensor, PT100 (P)	47	
	phase U1, main sensor, PT100 (N)	46	
Temperature 2	phase V1, main sensor, PT100 (P)	33	
	phase V1, main sensor, PT100 (N)	32	
Temperature 3	phase W1, main sensor, PT100 (P)	45	
	phase W1, main sensor, PT100 (N)	31	
Temperature 4	phase U2, main sensor, PT100 (P)	30	
	phase U2, main sensor, PT100 (N)	29	
Temperature 5	phase V2, main sensor, PT100 (P)	44	
	phase V2, main sensor, PT100 (N)	43	
Temperature 6	phase W2, main sensor, PT100 (P)	28	
	phase W2, main sensor, PT100 (N)	16	
Temperature 7	phase U1, spare sensor, PT100 (P)	42	+TEMP5
	phase U1, spare sensor, PT100 (N)	27	
Temperature 8	phase V1, spare sensor, PT100 (P)	15	+TEMP5
	phase V1, spare sensor, PT100 (N)	14	
Temperature 9	phase W1, spare sensor, PT100 (P)	40	+TEMP5
	phase W1, spare sensor, PT100 (N)	26	
Temperature 10	phase U2, spare sensor, PT100 (P)	41	+TEMP5
	phase U2, spare sensor, PT100 (N)	13	
Temperature 11	phase V2, spare sensor, PT100 (P)	39	+TEMP5
	phase V2, spare sensor, PT100 (N)	38	
Temperature 12	phase W2, spare sensor, PT100 (P)	25	+TEMP5
	phase W2, spare sensor, PT100 (N)	12	
Resolver COS	Resolver, RES_COS_N, Inbuilt non-contacting	35	
Resolver COS	Resolver, RES_COS_P, Inbuilt non-contacting	20	
Resolver SIN	Resolver, RES_SIN_N, Inbuilt non-contacting	36	
Resolver SIN	Resolver, RES_SIN_P, Inbuilt non-contacting	21	
Resolver EXCN	Resolver, EXCN, Inbuilt non-contacting	22	
Resolver EXCP	Resolver, EXCP, Inbuilt non-contacting	10	
Resolver shield	Resolver, SHIELD/GROUND, Inbuilt non-contacting	34	
Resolver2 COS	Resolver 2, RES_COS_N, Inbuilt non-contacting	37	+RES2
Resolver2 COS	Resolver 2, RES_COS_P, Inbuilt non-contacting	24	+RES2

*Pin configuration of LV-connector for EM-PMI540B-T3000/T4000 (+DUAL) (continued)*

Measurement	Description	PIN	Option
Resolver2 SIN	Resolver 2, RES_SIN_N, Inbuilt non-contacting	23	+RES2
Resolver2 SIN	Resolver 2, RES_SIN_P, Inbuilt non-contacting	11	+RES2
Resolver2 EXCN	Resolver 2, EXCN, Inbuilt non-contacting	9	+RES2
Resolver2 EXCP	Resolver 2, EXCP, Inbuilt non-contacting	8	+RES2
Resolver2 shield	Resolver 2, SHIELD/GROUND, Inbuilt non-contacting	4	+RES2
Bearing temperature, sensor 1	PT100	2	
Bearing temperature, sensor 1	PT100_GND	18	
Bearing temperature, sensor 2	PT100	3	
Bearing temperature, sensor 2	PT100_GND	19	

*Pin configuration of LV-connectors for EM-PMI540B-T1500/T2000 (Applicable for machine variant with -QUAD high voltage connections)*

LV-connector 1			
Measurement	Description	PIN	Option
Temperature 1	phase U1, main sensor, PT100 (P)	47	
	phase U1, main sensor, PT100 (N)	46	
Temperature 2	phase V1, main sensor, PT100 (P)	33	
	phase V1, main sensor, PT100 (N)	32	
Temperature 3	phase W1, main sensor, PT100 (P)	45	
	phase W1, main sensor, PT100 (N)	31	
Temperature 4	phase U2, main sensor, PT100 (P)	30	
	phase U2, main sensor, PT100 (N)	29	
Temperature 5	phase V2, main sensor, PT100 (P)	44	
	phase V2, main sensor, PT100 (N)	43	
Temperature 6	phase W2, main sensor, PT100 (P)	28	
	phase W2, main sensor, PT100 (N)	16	
Temperature 7	phase U3, main sensor, PT100 (P)	42	
	phase U3, main sensor, PT100 (N)	27	
Temperature 8	phase V3, main sensor, PT100 (P)	15	
	phase V3, main sensor, PT100 (N)	14	
Temperature 9	phase W3, main sensor, PT100 (P)	40	
	phase W3, main sensor, PT100 (N)	26	
Temperature 10	phase U4, main sensor, PT100 (P)	41	
	phase U4, main sensor, PT100 (N)	13	
Temperature 11	phase V4, main sensor, PT100 (P)	39	
	phase V4, main sensor, PT100 (N)	38	
Temperature 12	phase W4, main sensor, PT100 (P)	25	
	phase W4, main sensor, PT100 (N)	12	
Resolver COS	Resolver, RES_COS_N, Inbuilt non-contacting	35	
Resolver COS	Resolver, RES_COS_P, Inbuilt non-contacting	20	
Resolver SIN	Resolver, RES_SIN_N, Inbuilt non-contacting	36	
Resolver SIN	Resolver, RES_SIN_P, Inbuilt non-contacting	21	
Resolver EXCN	Resolver, EXCN, Inbuilt non-contacting	22	
Resolver EXCP	Resolver, EXCP, Inbuilt non-contacting	10	
Resolver shield	Resolver, SHIELD/GROUND, Inbuilt non-contacting	34	

*Pin configuration of LV-connectors for EM-PMI540B-T1500/T2000 (Applicable for machine variant with -QUAD high voltage connections) (continued)*

LV-connector 1			
Measurement	Description	PIN	Option
Reserve			
Reserve			
Reserve			
Reserve			
Reserve			
Reserve			
Bearing temperature, sensor 1	PT100	2	
Bearing temperature, sensor 1	PT100_GND	18	
Bearing temperature, sensor 2	PT100	3	
Bearing temperature, sensor 2	PT100_GND	19	

*Pin configuration of LV-connectors for EM-PMI540B-T3000/T4000 (+QUAD)*

LV-connector 1			
Measurement	Description	PIN	Option
Temperature 1	phase U1, main sensor, PT100 (P)	47	
	phase U1, main sensor, PT100 (N)	46	
Temperature 2	phase V1, main sensor, PT100 (P)	33	
	phase V1, main sensor, PT100 (N)	32	
Temperature 3	phase W1, main sensor, PT100 (P)	45	
	phase W1, main sensor, PT100 (N)	31	
Temperature 4	phase U2, main sensor, PT100 (P)	30	
	phase U2, main sensor, PT100 (N)	29	
Temperature 5	phase V2, main sensor, PT100 (P)	44	
	phase V2, main sensor, PT100 (N)	43	
Temperature 6	phase W2, main sensor, PT100 (P)	28	
	phase W2, main sensor, PT100 (N)	16	
Temperature 7	phase U3, main sensor, PT100 (P)	42	
	phase U3, main sensor, PT100 (N)	27	
Temperature 8	phase V3, main sensor, PT100 (P)	15	
	phase V3, main sensor, PT100 (N)	14	
Temperature 9	phase W3, main sensor, PT100 (P)	40	
	phase W3, main sensor, PT100 (N)	26	
Temperature 10	phase U4, main sensor, PT100 (P)	41	
	phase U4, main sensor, PT100 (N)	13	
Temperature 11	phase V4, main sensor, PT100 (P)	39	
	phase V4, main sensor, PT100 (N)	38	
Temperature 12	phase W4, main sensor, PT100 (P)	25	
	phase W4, main sensor, PT100 (N)	12	
Resolver COS	Resolver, RES_COS_N, Inbuilt non-contacting	35	
Resolver COS	Resolver, RES_COS_P, Inbuilt non-contacting	20	
Resolver SIN	Resolver, RES_SIN_N, Inbuilt non-contacting	36	
Resolver SIN	Resolver, RES_SIN_P, Inbuilt non-contacting	21	

## Pin configuration of LV-connectors for EM-PMI540B-T3000/T4000 (+QUAD) (continued)

LV-connector 1			
Measurement	Description	PIN	Option
Resolver EXCN	Resolver, EXCN, Inbuilt non-contacting	22	
Resolver EXCP	Resolver, EXCP, Inbuilt non-contacting	10	
Resolver shield	Resolver, SHIELD/GROUND, Inbuilt non-contacting	34	
Resolver2 COS	Resolver 2, RES_COS_N, Inbuilt non-contacting	37	+RES2
Resolver2 COS	Resolver 2, RES_COS_P, Inbuilt non-contacting	24	+RES2
Resolver2 SIN	Resolver 2, RES_SIN_N, Inbuilt non-contacting	23	+RES2
Resolver2 SIN	Resolver 2, RES_SIN_P, Inbuilt non-contacting	11	+RES2
Resolver2 EXCN	Resolver 2, EXCN, Inbuilt non-contacting	9	+RES2
Resolver2 EXCP	Resolver 2, EXCP, Inbuilt non-contacting	8	+RES2
Resolver2 shield	Resolver 2, SHIELD/GROUND, Inbuilt non-contacting	4	+RES2
Bearing temperature, sensor 1	PT100	2	
Bearing temperature, sensor 1	PT100_GND	18	
Bearing temperature, sensor 2	PT100	3	
Bearing temperature, sensor 2	PT100_GND	19	

LV-connector 2			
Measurement	Description	PIN	Option
Temperature 13	phase U1, spare sensor, PT100 (P)	47	+TEMP5
	phase U1, spare sensor, PT100 (N)	46	
Temperature 14	phase V1, spare sensor, PT100 (P)	33	+TEMP5
	phase V1, spare sensor, PT100 (N)	32	
Temperature 15	phase W1, spare sensor, PT100 (P)	45	+TEMP5
	phase W1, spare sensor, PT100 (N)	31	
Temperature 16	phase U2, spare sensor, PT100 (P)	30	+TEMP5
	phase U2, spare sensor, PT100 (N)	29	
Temperature 17	phase V2, spare sensor, PT100 (P)	44	+TEMP5
	phase V2, spare sensor, PT100 (N)	43	
Temperature 18	phase W2, spare sensor, PT100 (P)	28	+TEMP5
	phase W2, spare sensor, PT100 (N)	16	
Temperature 19	phase U3, spare sensor, PT100 (P)	42	+TEMP5
	phase U3, spare sensor, PT100 (N)	27	
Temperature 20	phase V3, spare sensor, PT100 (P)	15	+TEMP5
	phase V3, spare sensor, PT100 (N)	14	
Temperature 21	phase W3, spare sensor, PT100 (P)	40	+TEMP5
	phase W3, spare sensor, PT100 (N)	26	
Temperature 22	phase U4, spare sensor, PT100 (P)	41	+TEMP5
	phase U4, spare sensor, PT100 (N)	13	
Temperature 23	phase V4, spare sensor, PT100 (P)	39	+TEMP5
	phase V4, spare sensor, PT100 (N)	38	
Temperature 24	phase W4, spare sensor, PT100 (P)	25	+TEMP5
	phase W4, spare sensor, PT100 (N)	12	

## Bearing temperature measurement connector

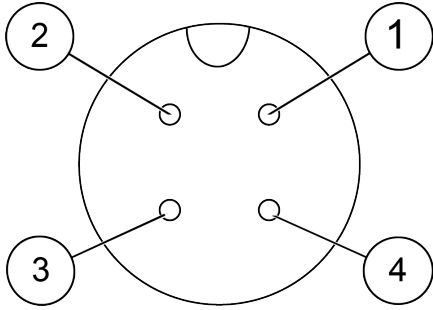

Measurement	Description	PIN
Bearing temperature, sensor 1	PT100	1
Bearing temperature, sensor 1	PT100_GND	2
Bearing temperature, sensor 2	PT100	3
Bearing temperature, sensor 2	PT100_GND	4

## Pin configuration of LV connections for EM-PMI540B-T1500/T2000 (Applicable for machine variant with -DUAL high voltage connections and +LVB1 option)

PIN	Measurement	Description	Option
<b>N-END</b>			
1 ↓	HEAT	Heater, ground / protective earth	+HEAT1
2	HEAT	Heater, neutral	+HEAT1
3	HEAT	Heater, phase, 230 V_AC	+HEAT1
4 ↓	Resolver shield	Resolver, SHIELD/GROUND, Inbuilt non-contacting	+RES1
5	Resolver COS	Resolver, RES_COS_N, Inbuilt non-contacting	+RES1
6	Resolver COS	Resolver, RES_COS_P, Inbuilt non-contacting	+RES1
7	Resolver SIN	Resolver, RES_SIN_N, Inbuilt non-contacting	+RES1
8	Resolver SIN	Resolver, RES_SIN_P, Inbuilt non-contacting	+RES1
9	Resolver EXCN	Resolver, EXCN, Inbuilt non-contacting	+RES1
10	Resolver EXCP	Resolver, EXCP, Inbuilt non-contacting	+RES1
11	Temperature 1	phase U1, main sensor, PT100 (P)	
12		phase U1, main sensor, PT100 (N)	
13	Temperature 2	phase V1, main sensor, PT100 (P)	
14		phase V1, main sensor, PT100 (N)	
15	Temperature 3	phase W1, main sensor, PT100 (P)	
16		phase W1, main sensor, PT100 (N)	
17	Temperature 4	phase U2, main sensor, PT100 (P)	
18		phase U2, main sensor, PT100 (N)	
19	Temperature 5	phase V2, main sensor, PT100 (P)	
20		phase V2, main sensor, PT100 (N)	
21	Temperature 6	phase W2, main sensor, PT100 (P)	
22		phase W2, main sensor, PT100 (N)	
23	Temperature 7	phase U1, spare sensor, PT100 (P)	+TEMP5
24		phase U1, spare sensor, PT100 (N)	
25	Temperature 8	phase V1, spare sensor, PT100 (P)	+TEMP5
26		phase V1, spare sensor, PT100 (N)	
27	Temperature 9	phase W1, spare sensor, PT100 (P)	+TEMP5
28		phase W1, spare sensor, PT100 (N)	
29	Temperature 10	phase U2, spare sensor, PT100 (P)	+TEMP5
30		phase U2, spare sensor, PT100 (N)	

Pin configuration of LV connections for EM-PMI540B-T1500/T2000 (Applicable for machine variant with -DUAL high voltage connections and +LVB1 option) (continued)

PIN	Measurement	Description	Option
31	Temperature 11	phase V2, spare sensor, PT100 (P)	+TEMP5
32		phase V2, spare sensor, PT100 (N)	
33	Temperature 12	phase W2, spare sensor, PT100 (P)	+TEMP5
34		phase W2, spare sensor, PT100 (N)	
35	TEMP		
36	TEMP		
37	TEMP		
38	TEMP		
39	TEMP		
40	TEMP		
41	TEMP		
42	TEMP		
43	TEMP		
44	TEMP		
45	TEMP		
46	TEMP		
47	TEMP		
48	TEMP		
49	TEMP		
50	TEMP		
51	TEMP		
52	TEMP		
53	TEMP		
54	TEMP		
55	TEMP		
56	TEMP		
57	TEMP		
58	TEMP		
59	Bearing temperature, sensor 1	PT100	+BTMP
60	Bearing temperature, sensor 1	PT100_GND	+BTMP
61	Bearing temperature, sensor 2	PT100	+BTMP
62	Bearing temperature, sensor 2	PT100_GND	+BTMP
63	Reserve		
64	Reserve		
65	Reserve		
66	Reserve		
<b>D-END</b>			
74	Bearing temperature, sensor 1	PT100	+BTMP
75	Bearing temperature, sensor 1	PT100_GND	+BTMP
76	Bearing temperature, sensor 2	PT100	+BTMP
77	Bearing temperature, sensor 2	PT100_GND	+BTMP

## Pin configuration of +LVB1 connection for EM-PMI540B-T3000/T4000 (+DUAL)

PIN	Measurement	Description	Option
<b>N-END</b>			
1 ↓	HEAT	Heater, ground / protective earth	+HEAT1
2	HEAT	Heater, neutral	+HEAT1
3	HEAT	Heater, phase, 230 V_AC	+HEAT1
4 ↓	Resolver shield	Resolver, SHIELD/GROUND, Inbuilt non-contacting	+RES1
5	Resolver COS	Resolver, RES_COS_N, Inbuilt non-contacting	+RES1
6	Resolver COS	Resolver, RES_COS_P, Inbuilt non-contacting	+RES1
7	Resolver SIN	Resolver, RES_SIN_N, Inbuilt non-contacting	+RES1
8	Resolver SIN	Resolver, RES_SIN_P, Inbuilt non-contacting	+RES1
9	Resolver EXCN	Resolver, EXCN, Inbuilt non-contacting	+RES1
10	Resolver EXCP	Resolver, EXCP, Inbuilt non-contacting	+RES1
11	Temperature 1	phase U1, main sensor, PT100 (P)	
12		phase U1, main sensor, PT100 (N)	
13	Temperature 2	phase V1, main sensor, PT100 (P)	
14		phase V1, main sensor, PT100 (N)	
15	Temperature 3	phase W1, main sensor, PT100 (P)	
16		phase W1, main sensor, PT100 (N)	
17	Temperature 4	phase U2, main sensor, PT100 (P)	
18		phase U2, main sensor, PT100 (N)	
19	Temperature 5	phase V2, main sensor, PT100 (P)	
20		phase V2, main sensor, PT100 (N)	
21	Temperature 6	phase W2, main sensor, PT100 (P)	
22		phase W2, main sensor, PT100 (N)	
23	Temperature 7	phase U1, spare sensor, PT100 (P)	+TEMP5
24		phase U1, spare sensor, PT100 (N)	
25	Temperature 8	phase V1, spare sensor, PT100 (P)	+TEMP5
26		phase V1, spare sensor, PT100 (N)	
27	Temperature 9	phase W1, spare sensor, PT100 (P)	+TEMP5
28		phase W1, spare sensor, PT100 (N)	
29	Temperature 10	phase U2, spare sensor, PT100 (P)	+TEMP5
30		phase U2, spare sensor, PT100 (N)	
31	Temperature 11	phase V2, spare sensor, PT100 (P)	+TEMP5
32		phase V2, spare sensor, PT100 (N)	
33	Temperature 12	phase W2, spare sensor, PT100 (P)	+TEMP5
34		phase W2, spare sensor, PT100 (N)	
35	TEMP		
36	TEMP		
37	TEMP		
38	TEMP		
39	TEMP		
40	TEMP		
41	TEMP		
42	TEMP		
43	TEMP		
44	TEMP		
45	TEMP		
46	TEMP		
47	TEMP		

## Pin configuration of +LVB1 connection for EM-PMI540B-T3000/T4000 (+DUAL) (continued)

PIN	Measurement	Description	Option
48	TEMP		
49	TEMP		
50	TEMP		
51	TEMP		
52	TEMP		
53	TEMP		
54	TEMP		
55	TEMP		
56	TEMP		
57	TEMP		
58	TEMP		
59	Bearing temperature, sensor 1	PT100	+BTMP
60	Bearing temperature, sensor 1	PT100_GND	+BTMP
61	Bearing temperature, sensor 2	PT100	+BTMP
62	Bearing temperature, sensor 2	PT100_GND	+BTMP
63	Reserve		
64	Reserve		
65	Reserve		
66	Reserve		
67 ↓	Resolver2 shield	Resolver 2, SHIELD/GROUND, Inbuilt non-contacting	+RES2
68	Resolver2 COS	Resolver 2, RES_COS_N, Inbuilt non-contacting	+RES2
69	Resolver2 COS	Resolver 2, RES_COS_P, Inbuilt non-contacting	+RES2
70	Resolver2 SIN	Resolver 2, RES_SIN_N, Inbuilt non-contacting	+RES2
71	Resolver2 SIN	Resolver 2, RES_SIN_P, Inbuilt non-contacting	+RES2
72	Resolver2 EXCN	Resolver 2, EXCN, Inbuilt non-contacting	+RES2
73	Resolver2 EXCP	Resolver 2, EXCP, Inbuilt non-contacting	+RES2
<b>D-END 1/2</b>			
74	Bearing temperature, sensor 1	PT100	+BTMP
75	Bearing temperature, sensor 1	PT100_GND	+BTMP
76	Bearing temperature, sensor 2	PT100	+BTMP
77	Bearing temperature, sensor 2	PT100_GND	+BTMP
<b>D-END 2/2</b>			
78 ↓	HEAT2	Heater 2, ground / protective earth	+HEAT2
79	HEAT2	Heater 2, neutral	+HEAT2
80	HEAT2	Heater 2, phase, 230 V_AC	+HEAT2

## Pin configuration of LV connection for EM-PMI540B-T1500/T2000 (Applicable for machine variant with -QUAD high voltage connections and +LVB1 option)

PIN	Measurement	Description	Option
<b>N-END</b>			
1 ↓	HEAT	Heater, ground / protective earth	+HEAT1
2	HEAT	Heater, neutral	+HEAT1

Pin configuration of LV connection for EM-PMI540B-T1500/T2000 (Applicable for machine variant with -QUAD high voltage connections and +LVB1 option) (continued)

PIN	Measurement	Description	Option
3	HEAT	Heater, phase, 230 V_AC	+HEAT1
4 ↓	Resolver shield	Resolver, SHIELD/GROUND, Inbuilt non-contacting	+RES1
5	Resolver COS	Resolver, RES_COS_N, Inbuilt non-contacting	+RES1
6	Resolver COS	Resolver, RES_COS_P, Inbuilt non-contacting	+RES1
7	Resolver SIN	Resolver, RES_SIN_N, Inbuilt non-contacting	+RES1
8	Resolver SIN	Resolver, RES_SIN_P, Inbuilt non-contacting	+RES1
9	Resolver EXCN	Resolver, EXCN, Inbuilt non-contacting	+RES1
10	Resolver EXCP	Resolver, EXCP, Inbuilt non-contacting	+RES1
11	Temperature 1	phase U1, main sensor, PT100 (P)	
12		phase U1, main sensor, PT100 (N)	
13	Temperature 2	phase V1, main sensor, PT100 (P)	
14		phase V1, main sensor, PT100 (N)	
15	Temperature 3	phase W1, main sensor, PT100 (P)	
16		phase W1, main sensor, PT100 (N)	
17	Temperature 4	phase U2, main sensor, PT100 (P)	
18		phase U2, main sensor, PT100 (N)	
19	Temperature 5	phase V2, main sensor, PT100 (P)	
20		phase V2, main sensor, PT100 (N)	
21	Temperature 6	phase W2, main sensor, PT100 (P)	
22		phase W2, main sensor, PT100 (N)	
23	Temperature 7	phase U3, main sensor, PT100 (P)	
24		phase U3, main sensor, PT100 (N)	
25	Temperature 8	phase V3, main sensor, PT100 (P)	
26		phase V3, main sensor, PT100 (N)	
27	Temperature 9	phase W3, main sensor, PT100 (P)	
28		phase W3, main sensor, PT100 (N)	
29	Temperature 10	phase U4, main sensor, PT100 (P)	
30		phase U4, main sensor, PT100 (N)	
31	Temperature 11	phase V4, main sensor, PT100 (P)	
32		phase V4, main sensor, PT100 (N)	
33	Temperature 12	phase W4, main sensor, PT100 (P)	
34		phase W4, main sensor, PT100 (N)	
35	Temperature 13	phase U1, spare sensor, PT100 (P)	+TEMP5
36		phase U1, spare sensor, PT100 (N)	
37	Temperature 14	phase V1, spare sensor, PT100 (P)	+TEMP5
38		phase V1, spare sensor, PT100 (N)	
39	Temperature 15	phase W1, spare sensor, PT100 (P)	+TEMP5
40		phase W1, spare sensor, PT100 (N)	
41	Temperature 16	phase U2, spare sensor, PT100 (P)	+TEMP5
42		phase U2, spare sensor, PT100 (N)	
43	Temperature 17	phase V2, spare sensor, PT100 (P)	+TEMP5
44		phase V2, spare sensor, PT100 (N)	
45	Temperature 18	phase W2, spare sensor, PT100 (P)	+TEMP5
46		phase W2, spare sensor, PT100 (N)	
47	Temperature 19	phase U3, spare sensor, PT100 (P)	+TEMP5
48		phase U3, spare sensor, PT100 (N)	

Pin configuration of LV connection for EM-PMI540B-T1500/T2000 (Applicable for machine variant with -QUAD high voltage connections and +LVB1 option) (continued)

PIN	Measurement	Description	Option
49	Temperature 20	phase V3, spare sensor, PT100 (P)	+TEMP5
50		phase V3, spare sensor, PT100 (N)	
51	Temperature 21	phase W3, spare sensor, PT100 (P)	+TEMP5
52		phase W3, spare sensor, PT100 (N)	
53	Temperature 22	phase U4, spare sensor, PT100 (P)	+TEMP5
54		phase U4, spare sensor, PT100 (N)	
55	Temperature 23	phase V4, spare sensor, PT100 (P)	+TEMP5
56		phase V4, spare sensor, PT100 (N)	
57	Temperature 24	phase W4, spare sensor, PT100 (P)	+TEMP5
58		phase W4, spare sensor, PT100 (N)	
59	Bearing temperature, sensor 1	PT100	+BTMP
60	Bearing temperature, sensor 1	PT100_GND	+BTMP
61	Bearing temperature, sensor 2	PT100	+BTMP
62	Bearing temperature, sensor 2	PT100_GND	+BTMP
63	Reserve		
64	Reserve		
65	Reserve		
66	Reserve		
<b>D-END</b>			
74	Bearing temperature, sensor 1	PT100	+BTMP
75	Bearing temperature, sensor 1	PT100_GND	+BTMP
76	Bearing temperature, sensor 2	PT100	+BTMP
77	Bearing temperature, sensor 2	PT100_GND	+BTMP

Pin configuration of +LVB1 connection for EM-PMI540B-T3000/T4000 (+QUAD)

PIN	Measurement	Description	Option
<b>N-END</b>			
1 ↓	HEAT	Heater, ground / protective earth	+HEAT1
2	HEAT	Heater, neutral	+HEAT1
3	HEAT	Heater, phase, 230 V_AC	+HEAT1
4 ↓	Resolver shield	Resolver, SHIELD/GROUND, Inbuilt non-contacting	+RES1
5	Resolver COS	Resolver, RES_COS_N, Inbuilt non-contacting	+RES1
6	Resolver COS	Resolver, RES_COS_P, Inbuilt non-contacting	+RES1
7	Resolver SIN	Resolver, RES_SIN_N, Inbuilt non-contacting	+RES1
8	Resolver SIN	Resolver, RES_SIN_P, Inbuilt non-contacting	+RES1
9	Resolver EXCN	Resolver, EXCN, Inbuilt non-contacting	+RES1
10	Resolver EXCP	Resolver, EXCP, Inbuilt non-contacting	+RES1
11	Temperature 1	phase U1, main sensor, PT100 (P)	
12		phase U1, main sensor, PT100 (N)	
13	Temperature 2	phase V1, main sensor, PT100 (P)	
14		phase V1, main sensor, PT100 (N)	







## Pin configuration of +LVB1 connection for EM-PMI540B-T3000/T4000 (+QUAD) (continued)

PIN	Measurement	Description	Option
15	Temperature 3	phase W1, main sensor, PT100 (P)	
16		phase W1, main sensor, PT100 (N)	
17	Temperature 4	phase U2, main sensor, PT100 (P)	
18		phase U2, main sensor, PT100 (N)	
19	Temperature 5	phase V2, main sensor, PT100 (P)	
20		phase V2, main sensor, PT100 (N)	
21	Temperature 6	phase W2, main sensor, PT100 (P)	
22		phase W2, main sensor, PT100 (N)	
23	Temperature 7	phase U3, main sensor, PT100 (P)	
24		phase U3, main sensor, PT100 (N)	
25	Temperature 8	phase V3, main sensor, PT100 (P)	
26		phase V3, main sensor, PT100 (N)	
27	Temperature 9	phase W3, main sensor, PT100 (P)	
28		phase W3, main sensor, PT100 (N)	
29	Temperature 10	phase U4, main sensor, PT100 (P)	
30		phase U4, main sensor, PT100 (N)	
31	Temperature 11	phase V4, main sensor, PT100 (P)	
32		phase V4, main sensor, PT100 (N)	
33	Temperature 12	phase W4, main sensor, PT100 (P)	
34		phase W4, main sensor, PT100 (N)	
35	Temperature 13	phase U1, spare sensor, PT100 (P)	+TEMP5
36		phase U1, spare sensor, PT100 (N)	
37	Temperature 14	phase V1, spare sensor, PT100 (P)	+TEMP5
38		phase V1, spare sensor, PT100 (N)	
39	Temperature 15	phase W1, spare sensor, PT100 (P)	+TEMP5
40		phase W1, spare sensor, PT100 (N)	
41	Temperature 16	phase U2, spare sensor, PT100 (P)	+TEMP5
42		phase U2, spare sensor, PT100 (N)	
43	Temperature 17	phase V2, spare sensor, PT100 (P)	+TEMP5
44		phase V2, spare sensor, PT100 (N)	
45	Temperature 18	phase W2, spare sensor, PT100 (P)	+TEMP5
46		phase W2, spare sensor, PT100 (N)	
47	Temperature 19	phase U3, spare sensor, PT100 (P)	+TEMP5
48		phase U3, spare sensor, PT100 (N)	
49	Temperature 20	phase V3, spare sensor, PT100 (P)	+TEMP5
50		phase V3, spare sensor, PT100 (N)	
51	Temperature 21	phase W3, spare sensor, PT100 (P)	+TEMP5
52		phase W3, spare sensor, PT100 (N)	
53	Temperature 22	phase U4, spare sensor, PT100 (P)	+TEMP5
54		phase U4, spare sensor, PT100 (N)	
55	Temperature 23	phase V4, spare sensor, PT100 (P)	+TEMP5
56		phase V4, spare sensor, PT100 (N)	
57	Temperature 24	phase W4, spare sensor, PT100 (P)	+TEMP5
58		phase W4, spare sensor, PT100 (N)	
59	Bearing temperature, sensor 1	PT100	+BTMP
60	Bearing temperature, sensor 1	PT100_GND	+BTMP

## Pin configuration of +LVB1 connection for EM-PMI540B-T3000/T4000 (+QUAD) (continued)

PIN	Measurement	Description	Option
61	Bearing temperature, sensor 2	PT100	+BTMP
62	Bearing temperature, sensor 2	PT100_GND	+BTMP
63	Reserve		
64	Reserve		
65	Reserve		
66	Reserve		
67 ↓	Resolver2 shield	Resolver 2, SHIELD/GROUND, Inbuilt non-contacting	+RES2
68	Resolver2 COS	Resolver 2, RES_COS_N, Inbuilt non-contacting	+RES2
69	Resolver2 COS	Resolver 2, RES_COS_P, Inbuilt non-contacting	+RES2
70	Resolver2 SIN	Resolver 2, RES_SIN_N, Inbuilt non-contacting	+RES2
71	Resolver2 SIN	Resolver 2, RES_SIN_P, Inbuilt non-contacting	+RES2
72	Resolver2 EXCN	Resolver 2, EXCN, Inbuilt non-contacting	+RES2
73	Resolver2 EXCP	Resolver 2, EXCP, Inbuilt non-contacting	+RES2
<b>D-END 1/2</b>			
74	Bearing temperature, sensor 1	PT100	+BTMP
75	Bearing temperature, sensor 1	PT100_GND	+BTMP
76	Bearing temperature, sensor 2	PT100	+BTMP
77	Bearing temperature, sensor 2	PT100_GND	+BTMP
<b>D-END 2/2</b>			
78 ↓	HEAT2	Heater 2, ground / protective earth	+HEAT2
79	HEAT2	Heater 2, neutral	+HEAT2
80	HEAT2	Heater 2, phase, 230 V_AC	+HEAT2

## Grounding connections

	<b>Ground the electric machine from its frame to make sure it functions correctly and safely.</b>
	<b>Ground the cable shields of the power cables to make sure the electric machine functions correctly and safely.</b>
	<b>Ground the cable shields of the instrumentation cables to make sure the electric machine functions correctly and safely.</b>
	<b>The cross sectional area of the protective earth conductor must be at least equal to that of the incoming supply conductor.</b>
	<b>It is recommended to perform a ground bond test after installing the electric machine to make sure the electric machine is correctly grounded.</b>
	<b>The grounding points on the frame of the electric machine are for safety grounding, and signal cables and power cable shields have their own grounding points.</b>

*The machine enclosure grounding point, safety grounding*

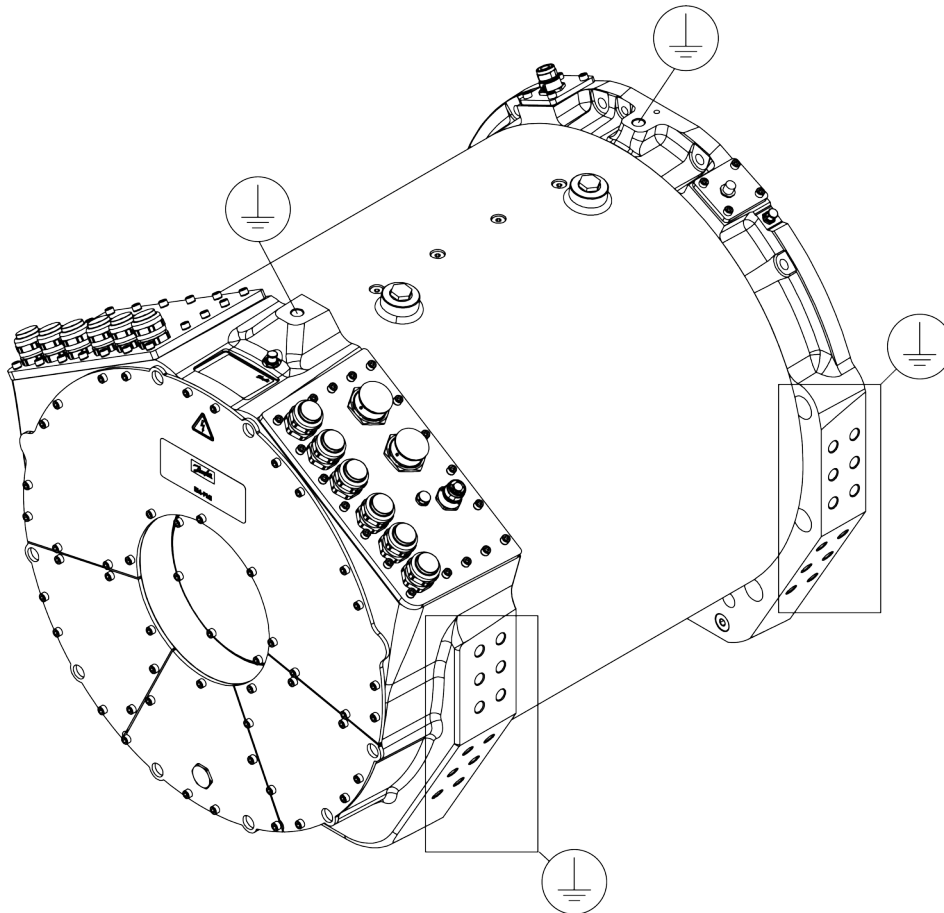

Side/Foot/V-mounting bores can be used for grounding if they are not in use.

*Low voltage cable grounding points*

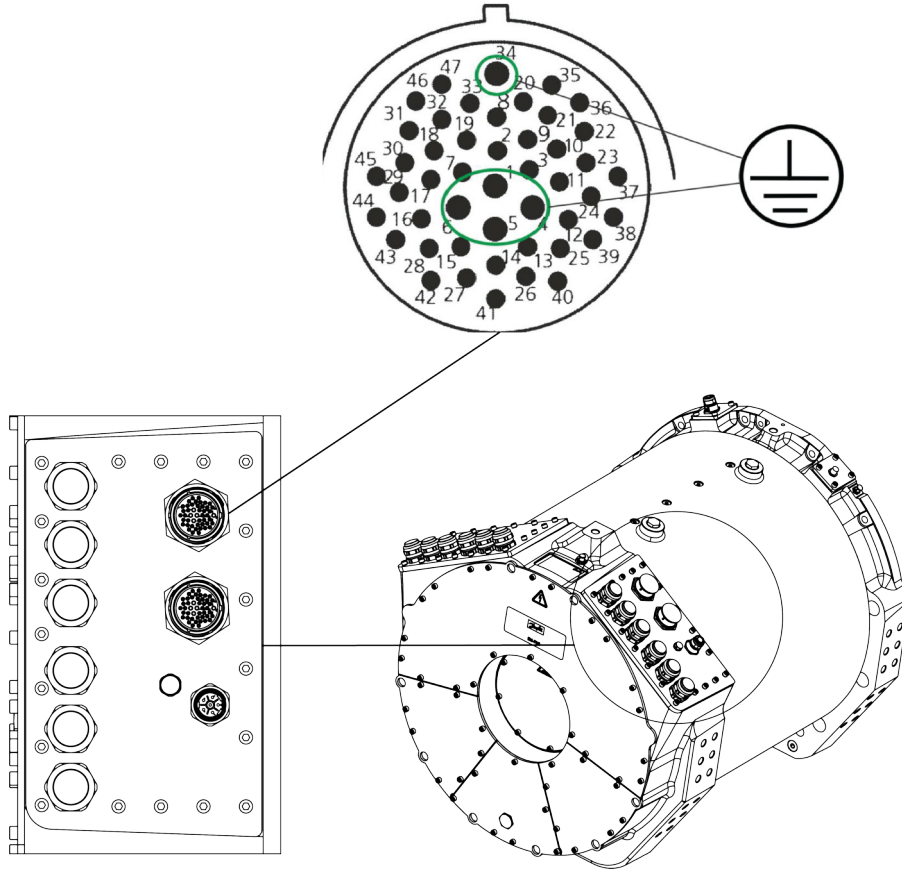

*Power cable grounding through the cable gland*

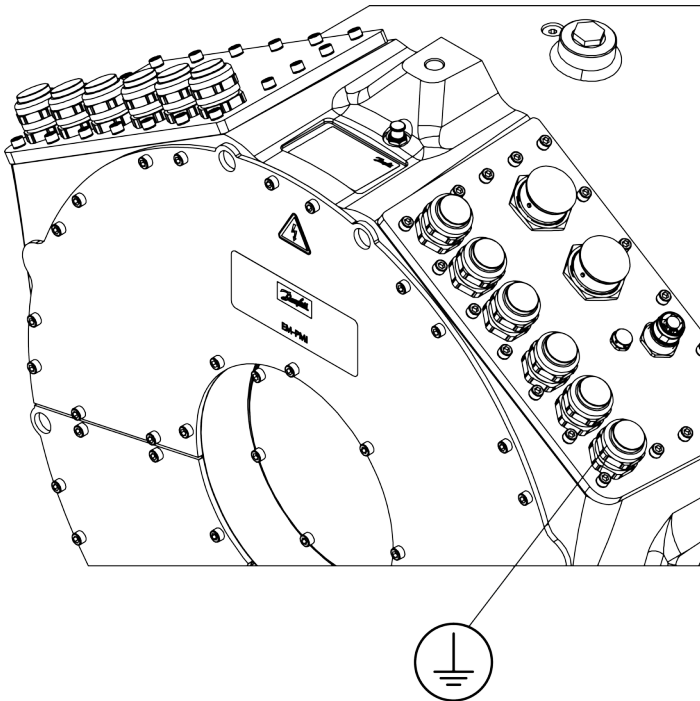

**Testing the power cable shield grounding (earthing)**

1. Connect one terminal of the measurement device to the cable shield of one power cable (in the inverter end of the cable)
2. Connect the other terminal of the measurement device to the cable shield of an other power cable. You can also use the machine enclosure grounding point for the measurement.
3. Measure the resistance between the two cable shields or between the cable shield and the enclosure grounding point.
4. Change the measurement device terminal(s) to the shield of different power cable and repeat the measurement until all cables have been measured.

#### Testing the low voltage (measurement signal) cable shield grounding (earthing)

The low voltage (measurement signal) cable shield connects to the ground through the connector grounding/earthing pins. After cable installation, and any time when needed, make sure that the grounding (earthing) connection is valid.

1. Connect one terminal of the measurement device to the low voltage cable shield (in the non-machine end of the cable).
2. Connect the other terminal of the measurement device to the machine enclosure grounding point.
3. Measure the resistance between the cable shield and the enclosure grounding point.

#### Anti-condensation heater connections



**Do not run the electric machine when an anti-condensation heater is in use.**

Water condensing inside the electric machine enclosure can result in failure or corrosion of the electric machine. This often happens in cooler temperatures or higher humidity areas typically in marine environment, when the machine is not running.

The electric machine can be equipped with anti-condensation heaters to avoid condensation issues. The anti-condensation heaters (+HEAT2) are factory assembled. The installed heaters may not be used when the electric machine mains are switched on or when the electric machine is running.

A 230 V<sub>AC</sub> power supply is required for the anti-condensation heater. The connection is made using a HUMMEL Twilock connector, shown in the figure below.

For the location of the heater connectors, see [Connections and interfaces](#) on page 17.

*Connection of the heater element*

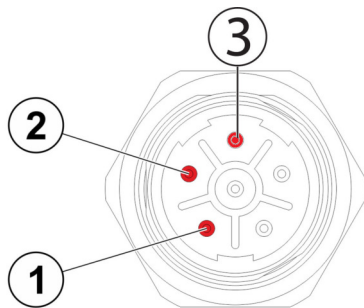

1	L
2	N
3	PE







After the installation of the electric machine, and any time when needed, the resistance of the warming element can be measured. Connect the measurement device between the heater terminals. The resistance should be around 1 k $\Omega$ . Measuring no value, or zero value, indicates a possible failure in the heater element.

If the electric machine has an anti-condensation heater and failure is suspected, contact Danfoss representative.

## Operation

This chapter provides essential guidelines for safely and effectively operating the electric machine. It outlines the recommended operating conditions, monitoring practices, and emergency procedures to ensure optimal performance and longevity.

For electric machines with multiple winding systems (e.g., -DUAL or -QUAD), it must be verified during commissioning that each winding set rotates in the same direction.

	<b>Only trained and qualified personnel familiar with the relevant safety requirements are allowed to operate the electric machine.</b>
	<b>Do not use the electric machine without properly dimensioned and operating cooling system. Maximum operation temperature, current and rotational speed of the electric machine must not be exceeded to avoid permanent damage.</b>
	<b>The surface of the electric machine might be hot. Do not touch the electric machine during operation.</b>
	<b>Entanglement hazard! Do not touch the electric machine during operation.</b>
	<b>Use sufficient personal protective equipment when you are near the electric machine.</b>
	<b>Read the instructions in this user guide before you install the electric machine.</b>

## Operation conditions

The electric machine should be used for its intended purpose only and within limits specified by the manufacturer, concerning:





- Loading.
- Cooling.
- Speed range.
- Service interval.
- Ambient conditions such as temperature and moisture.

The electric machine is designed for these conditions:

- Ambient temperature limits: -40°C...+85°C.
- Maximum altitude up to 4000 m above sea level (for details, see the product data sheet).
- Maximum coolant liquid temperature: +65°C (for details, see the product data sheet).

If the operation limits are exceeded and the electric machine is damaged, please contact local Danfoss representative.

## Condition monitoring during operation



	<b>Supervise the electric machine during operation to make sure that the electric machine operates correctly and has a designed lifetime.</b>
	<b>If you notice any deviations from the normal operation, for example elevated temperatures, noise or vibration, stop the electric machine. Find the reason for the deviation and repair the electric machine. Refer to Chapter <i>Troubleshooting</i> on page 79.</b>
	<b>Electrical safety of the system and the end application has to be guaranteed using appropriate methods, like external insulation resistance or residual current monitoring, depending on the application.</b>
	<b>Maximum temperature of the bearings of the electric machine is: 120°C.</b>
	<b>The maximum allowed winding temperature of the electric machine is shown on the rating plate and in the data sheet.</b>

## Recommended lubricants

	<b>Do not mix different types of lubricants!</b>
---	--

The recommended grease type for the machine bearings is SKF LGHP-2 or equivalent. LGHP-2 is high performance, high temperature bearing grease. For further information, see <http://www.skf.com/>.

## Recommended coolants

	<b>Ethylene glycol is a toxic compound. Avoid exposure to the coolant.</b>
	<b>Copper ions concentration of more than approx. 0.06 ppm causes <i>copper induced pitting corrosion</i>. Do not use copper components in the cooling system.</b>
	<b>Use correct personal protective equipment when you handle the coolant.</b>

For optimal performance, use a water-based coolant with the electric machines. Suitable coolants include plain water with an appropriate corrosion inhibitor, or a 50/50 mixture of water and glycol with a corrosion inhibitor added.

Glycol coolant options:

- Ethylene glycol based Glysantin® G48® (includes also corrosion inhibitors).
- Propylene glycol-based coolants, like Splash® RV&Marine antifreeze.

## Emergency operation

The electric machine should be operated within the operation limits and in the conditions specified by the manufacturer. However, it can be used with some limitations in the following fault/emergency situations.

### ***Cooling of the electric machine fails***

Cooling system failure can be caused by sediment accumulating in the cooling system tubes. Try opening the possible blockage by changing the coolant flow direction. See also Chapter *Cooling system maintenance*.





If the cooling of the electric machine fails, limited operation is still possible with no coolant flow. The operation speed must be limited to half (1/2) of the rated speed and maximum 20 % of the nominal torque may be used. In such case, the electric machine may be operated for maximum one hour. Repair the cooling system as soon as possible. For further information, contact Danfoss representative.

### **Danfoss service contact information**



Contact Danfoss service at <https://danfosseditron.zendesk.com/hc/en-gb> or send email to [editron.service@danfoss.com](mailto:editron.service@danfoss.com).

## Maintenance

This Chapter contains necessary information for the qualified and trained personnel to carry out regular maintenance work.

	<b>Do not disassemble the electric machine. Only procedures described in this user guide may be done.</b>
	<b>Only trained and qualified personnel familiar with the relevant safety requirements are allowed to do maintenance to the electric machine.</b>
	<b>Risk of electric shock when the connection box is open.</b>
	<b>Use correct personal protective equipment when you are near the electric machine.</b>
	<b>Read the instructions in the user guide before you start to work with the electric machine. To make sure that the operation of the electric machine is safe and reliable, obey the maintenance instructions.</b>

## Regular maintenance

	<b>Inspect the electric machine at regular intervals.</b>
	<b>Do not attempt to tighten bolts or screws that are not discussed in this user guide and that are not needed for normal installation and maintenance procedures. The sealing of the bolts and screws can break.</b>

Correct supervision and maintenance of the electric machine makes sure that the electric machine has reliable operation and designed lifetime.



### Maintenance schedule

Object	Check/Task	Weekly	Monthly	Yearly	
General construction	Operation	Noise, vibration. If clearly increased, contact Danfoss.	X		
	Mounting	Bolt tightness. Tighten to proper value if necessary. Applies to bolts and screws that are discussed in this user guide. See Chapter <i>Tightening torques</i> .			X
	Bearings	Detect any unusual noise or vibration. If exists, contact Danfoss.			X
	Enclosure and connected parts	Check cleanliness. Clean if necessary. See Chapter <i>Cleaning</i> .		X	
	Shaft seals	Check the wear. Replace if necessary.			X

*Maintenance schedule (continued)*

Object		Check/Task	Weekly	Monthly	Yearly
Electrical system	Cables	Wearing of the cables. Replace if necessary.		X	
	Electrical connections	Check connections. Make sure that tightening torque is correct for the cable glands. See Chapter <i>Tightening torques</i> .			X
	Groundings (earthings)	Check groundings (earthings). Make sure that the connection resistance is correct. Re-connect if necessary.			X
	Anti-condensation heater	Check anti-condensation heater connections and resistance, if the option is installed. If needed, contact Danfoss.			X
Cooling system	Operation	Functioning. Cooling system functions as specified.	X		
	Tubing and connection tightness	No visible leakage. If leaking, tighten the connections, or replace parts.		X	
	Ventilation plug	Cleanliness. Clean if necessary. See Chapter <i>Cleaning</i> .		X	
	Coolant flow	Coolant flow direction. It is recommended to change the coolant flow direction by changing the connections or flow direction from the pump. See Chapter <i>Cooling system maintenance</i> .			X
	Coolant quality	Coolant as specified. Correct glycol used, and water/glycol mixture correct. Refill if necessary. See Chapter <i>Cooling system maintenance</i> .			X
Lubrication	Relubrication (grease lubricated bearings)	Relubricate depending on the use (see Chapter <i>Bearings and lubrication</i> ). Maximum relubrication interval is six months.		X	

## Cleaning

	<b>To ensure watertight integrity and prevent water damage, never open or remove the ventilation plugs. Clean them only from the exterior surface.</b>
	<b>Risk of electric shock if the electric machine is cleaned against instructions allowing water to go in to the electric machine.</b>

Keep the electric machine clean. For cleaning, use non-abrasive and non-corrosive cleaning products.

Make sure that the detergent may be used for aluminum.

When pressure washing the electric machine, make sure that the water spray does not directly hit the gaskets.

*Ventilation plugs*

Do not open/remove watertight ventilation plugs. Clean externally only.

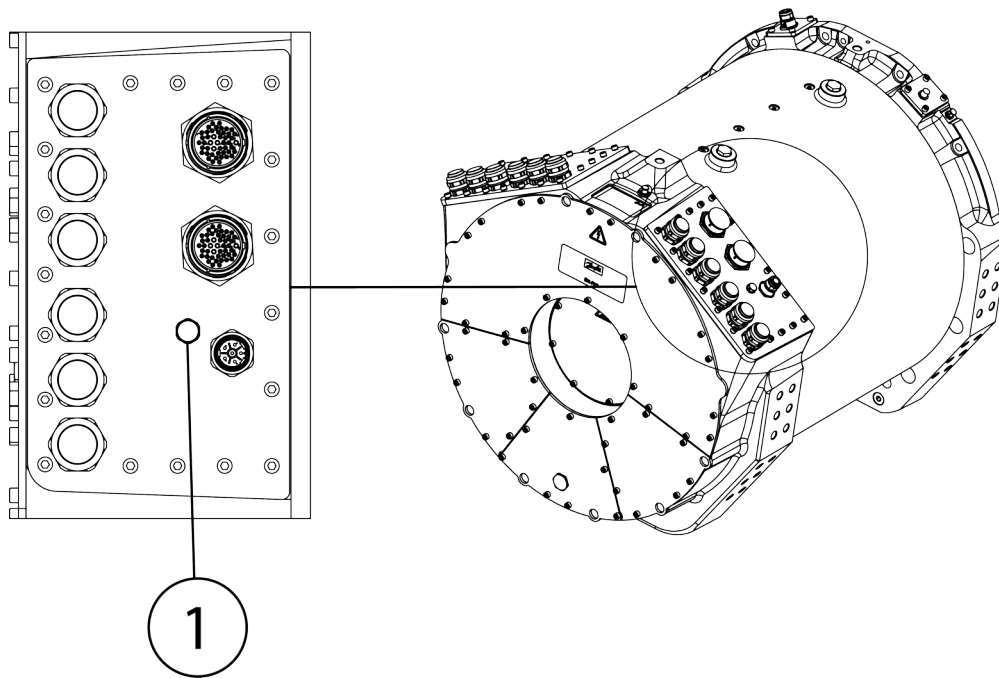

1	Ventilation plug (do not remove)
---	----------------------------------

## Bearings and lubrication

### Grease relubricable bearings

	<b>Lubricants can cause skin irritation and eye inflammation. Follow all safety precautions specified by the manufacturer of the lubricant.</b>
	<b>The bearing type of the electric machine can be found on the rating plate of the electric machine.</b>

Regular greasing is required for relubricable bearings. Follow the relubrication intervals and instructions outlined in this chapter.

It is recommended to have a piping for the grease exiting the electric machine. The grease exit hole is often in an inconvenient location when the electric machine is installed.

The bearing type for the electric machines EM-PMI540B-T1500 and EM-PMI540B-T2000 is 6214/C3 (non-insulated bearings) or 6214/C3 HC5 (insulated bearing). See the recommended lubricant in Chapter *Recommended lubricants* on page 71.

The bearing type for the electric machines EM-PMI540B-T3000 and EM-PMI540B-T4000 is 6216/C3 (non-insulated bearings) or 6216/C3VL0241 (insulated bearing). See the recommended lubricant in Chapter *Recommended lubricants* on page 71.

### Bearing relubrication

	<b>Beware of rotating parts. Do not touch the electric machine during operation.</b>
	<b>The surface of the electric machine can be hot. Use correct protective equipment (heat resistant gloves) when you handle the electric machine.</b>



**The information of bearing lifetime and bearing grease lifetime are estimations only to provide a magnitude of them. The bearing lifetime and bearing grease lifetime in customer application may vary. Danfoss is not responsible for the actual bearing lifetime in use. For further information, contact Danfoss representative.**



**The maximum interval between relubrication cycles during operation is six months. Apply 20 g of grease per relubrication.**

Relubrication intervals, which are dependent on rotation speed and bearing temperature, are shown in the figure below. Higher speeds and temperatures require more frequent relubrication. The figure displays curves for different bearing temperatures.

The maximum interval between relubrication cycles during operation is six months. Apply 20 grams of grease per relubrication.

*Relubrication interval of the machine compared to rotation speed and bearing temperature*

For electric machines EM-PMI540B-T1500 and EM-PMI540B-T2000:

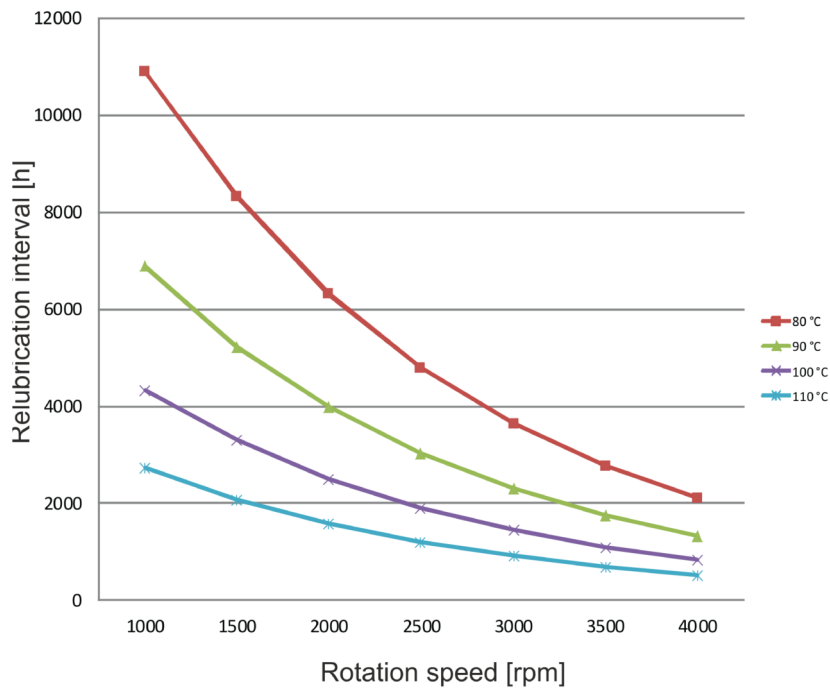

For electric machines EM-PMI540B-T3000 and EM-PMI540B-T4000:

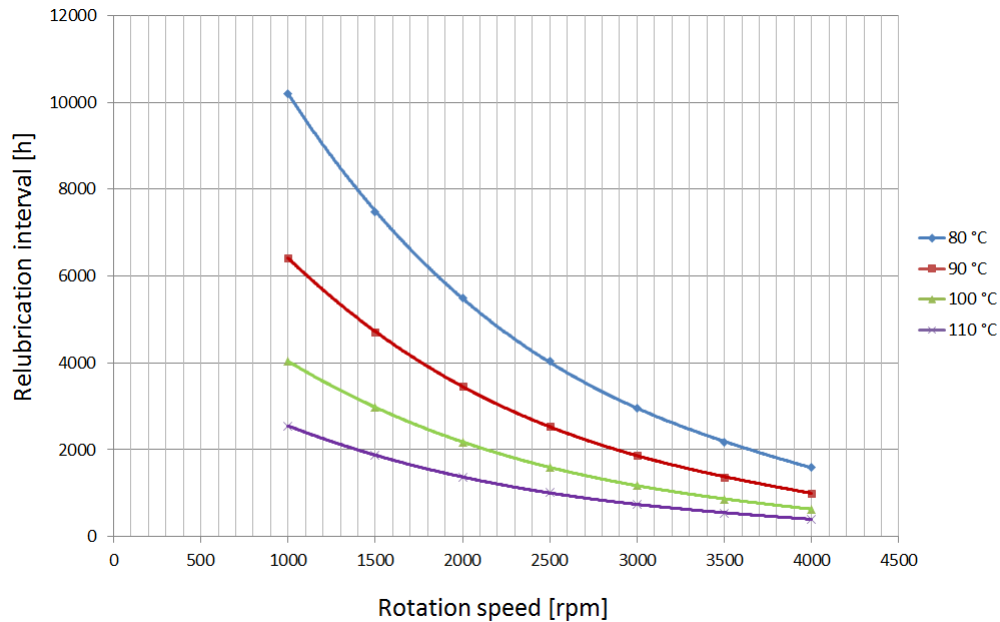

For more information about the location of grease nipples and grease escape holes, see Chapter *Connections and interfaces* on page 17.

#### Bearing relubrication:

It is normal if no grease exits the electric machine. This is because the cavities inside the electric machine can hold a lot of grease.

1. Make sure that the electric machine has reached its operating temperature.
2. Remove the plugs from the grease escape hole(s).

Select which grease escape hole you want to use at N-end (no need to use both).

Make sure that grease from D-end does not push to N-end and vice versa.

3. Open the grease nipple plug(s).
4. Use grease piston to enter specific amount of grease into the grease nipple.
5. After re-greasing, the electric machine must be restarted with a short idle time of 10...15 % of the rated speed, so that the grease is transferred and settled to the rolling surfaces of the bearing.
6. Install the plug(s) on the grease nipple(s) and on the grease escape hole(s).

#### Cooling system maintenance

It is recommended to change the direction of the coolant liquid flow yearly. This is done by changing the order of the coolant connections, or changing the coolant pump direction. The reason for changing the coolant flow direction is to prevent possible dregs (sediment) accumulating to the cooling system.

## Dismounting



**Make sure that the mating structure is not damaged. Do not pluck any bores or use at headed bolts or rods for pushing the electric machine out of the mating structure.**

For dismounting the electric machine, follow the Steps below.

1. Prepare the electric machine for lifting, for more information refer to Chapter *Lifting* on page 28. Support the electric machine with lifting slings when dismounting.
2. Loosen the mounting bolts. For more information refer to Chapter *Mounting the electric machine* on page 37.
3. If force is required, use the bores in D-end flange to push the electric machine out from the mating structure, or use some other method that does not damage the electric machine.
4. Lift the electric machine off. Support the electric machine when lifting.

## Troubleshooting

Some difficulties may occur while operating the electric machine. Possible causes and actions are given in the Table below. If the situation occurs, it should be corrected as soon as possible. These instructions do not cover all details or variations in the equipment nor provide information for every possible condition to be met in connection with installation, operation or maintenance.

For more information, contact Danfoss service at <https://danfosseditron.zendesk.com/hc/en-gb> or send email to [editron.service@danfoss.com](mailto:editron.service@danfoss.com).

### Troubleshooting chart

Symptom	Possible cause	Action
Excessive vibration, noise	Imbalance at the connected electric machine or the powertrain components.	Check the balance and installation of the drivetrain components.
	Misalignment between the electric machine and the used device.	Check the shaft connections and couplings. Ensure that the alignment is within the specifications listed in Chapter <i>Shaft alignment and load</i> on page 26.
	Attachment bolts are loose.	Replace and tighten the bolts.
	Clearance at the spline connection.	Check the spline connection.
	Imbalance at the electric machine.	Contact local Danfoss representative.
	Particles inside the electric machine.	
	Bearing damage.	Apply bearing lubricant/grease. See Chapter <i>Bearings and lubrication</i> . Contact local Danfoss representative for further information.
Inadequate lubrication (grease lubricated bearings).		
Bearing temperature rise	Inadequate lubrication (grease lubricated bearings).	Apply bearing lubricant/grease. See Chapter <i>Bearings and lubrication</i> .
	Too much grease in the bearing housing (grease lubricated bearings).	Open grease escape valve and let the electric machine run for 10 min. Clean the grease escape channel from solidified grease using brush if necessary.
	Incorrect bearing grease.	Check that the used grease is of correct type.
	Overloaded bearing.	Check that the system is not causing excess force or vibration to the machine bearings. Check the alignment of the machine shaft, see Chapter <i>Shaft alignment and load</i> on page 26.
	Bearing damage.	Contact local Danfoss representative for further information.
	Incorrect mounting option	Check motor mounting orientation and confirm that the motor has the correct option (vertical or horizontal mounting).
Electric machine overheating	Overload.	Reduce load. Check the machine rating plate and ensure that inverter limits are set accordingly.
	Cooling system failure.	Check the cooling system integrity, flow and fluid temperature. Change the cooling flow direction to flush the cooling system from sediment that has possibly accumulated. See also Chapter <i>Emergency operation</i> .
	Leakage in the cooling system.	Check the cooling system circuit and tighten the leaking connections.
	Rigid particle inside the machine cooling channel.	Try pulsating coolant to open the channels. Contact local Danfoss representative.
	Wrong machine parameters in the inverter.	Check and correct the machine parameters in the inverter.
	Damaged winding.	Measure the insulation resistance. Measure the winding resistance with a high-precision DC resistance meter and compare to manufacturer specifications. Replace the electric machine if necessary.
	Inverter switching frequency too low.	If other than a Danfoss Editron inverter is used, ensure that the switching frequency is at least equal to the required minimum switching frequency of the motor. See corresponding product data sheet.

## Troubleshooting chart (continued)

Symptom	Possible cause	Action
Connection box and / or motor cables overheating	Cable lug bolts loose.	Check torque of cable lug bolts. See also Chapter <i>Power connections</i> on page 40.
	Cable diameter too small.	Replace power cables with appropriate cable type.
	Cable lug crimps insufficient or incorrect.	Replace cable lugs. Use recommended cable lugs and crimping tools.
	Contamination or insulating substance between cable lug and bus bar.	Check that the contact surfaces of the bus bars and cable lugs are clean and undamaged. Ensure there is no grease, thread locking compound, dirt or other foreign substances between the bus bar and cable lug.
Significant lubricant leak	Worn radial lip seal.	Contact local Danfoss representative.
	Block at the grease outlet channel.	Clean the grease escape channel from solidified grease using brush if necessary.
Electric machine does not work properly or the performance is poor	Wrong electric machine parameters in the inverter.	Check and correct the electric machine parameters from the inverter. See inverter user manual and other relevant documentation.
	Demagnetization of magnets due to overheating.	Check that the back-EMF of the motor is within specifications. Contact local Danfoss representative. Replace the electric machine if necessary.
	Bearing fault.	Check the bearing temperature, lubrication and conditions. Contact local Danfoss representative for further information.
	Insulation or winding fault.	Measure the insulation resistance, refer to the manufacturer limits. See Chapter <i>Insulation resistance test</i> . Measure the winding resistance with a high-precision DC resistance meter and compare to manufacturer specifications. Replace the electric machine if necessary.
Moisture and / or corrosion inside the connection box or motor	Cable glands installed incorrectly.	Check tightening torque and sealing of the cable glands.
	Power cables installed incorrectly.	Check cable installation and sealing with cable glands.
	Connection box cover bolts are too loose, too tight, or cover seal is damaged.	Check the integrity of the seal on the connection box cover. Tighten the cover bolts to the specified torque.
	Low voltage connector damaged or not connected.	Contact local Danfoss representative.
	Breather cap blocked.	Check that the breather cap of the electric machine is not submerged in liquid, painted, or covered by any object
Temperature measurement failure	The PT100 sensor is faulty.	Measure the resistance of the PT100 sensor, see Chapter <i>Low voltage connections</i> . If the sensor is faulty, read out the signal from another sensor. Contact local Danfoss representative. See also Chapter <i>Emergency operation</i> .
Resolver sensor failure	Resolver wiring is faulty.	Check the wiring of the resolver and make sure that a shielded and twisted pair cable is used with the correct pairing of the signals.
	Resolver sensor is damaged.	Contact local Danfoss representative.

## Aftersales

### Service policy

Maintenance and service of the electric machine is limited to the procedures described in this user guide.

If the electric machine has service parts available, you can find them in Chapter *Service parts* on page 81.

For further information, go to <https://danfosseditron.zendesk.com/hc/en-gb> or send email to [editron.service@danfoss.com](mailto:editron.service@danfoss.com).

### Service parts

The recommended service parts are listed in this Section. Maintenance procedures not described in this user guide require special tools and instructions. Contact Danfoss for more information and purchasing.

#### **Service part kits for EM-PMI540B-T1500 / T2000**

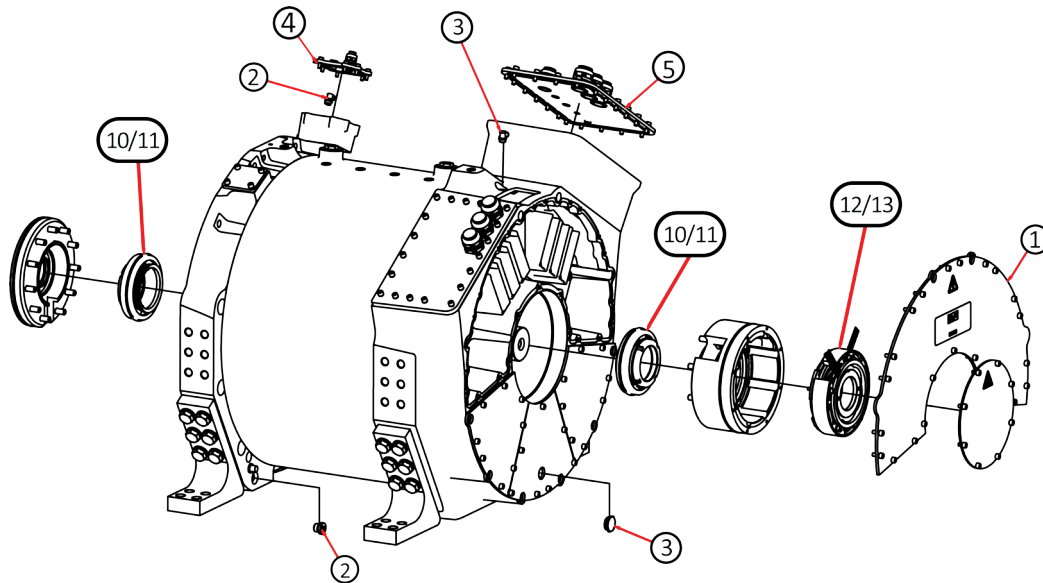

Position	Kit name	Description	Order number
1	HV terminal box cover	Replacement seals/bolts	11333593
2	Plugs D-end	Replacement plug/seal	11334553
3	Plugs, N-end	Replacement plug/seal	11334535
4	LV terminal box cover, D-end (with +LVB1)	Replacement seals/bolts	11333587
5	LV terminal box cover, N-end (with +LVB1)	Replacement seals/bolts	11333592 (*)
10	Bearing kit, non-insulated	Bearing replacement kit	11334707
11	Bearing kit, BIN	Bearing replacement kit	11334711
12	Resolver 1	RES1 replacement kit	11334684
13	Resolver 2	RES2 replacement kit	11334683

(\* Correct kit needs to be specified according to machine options.

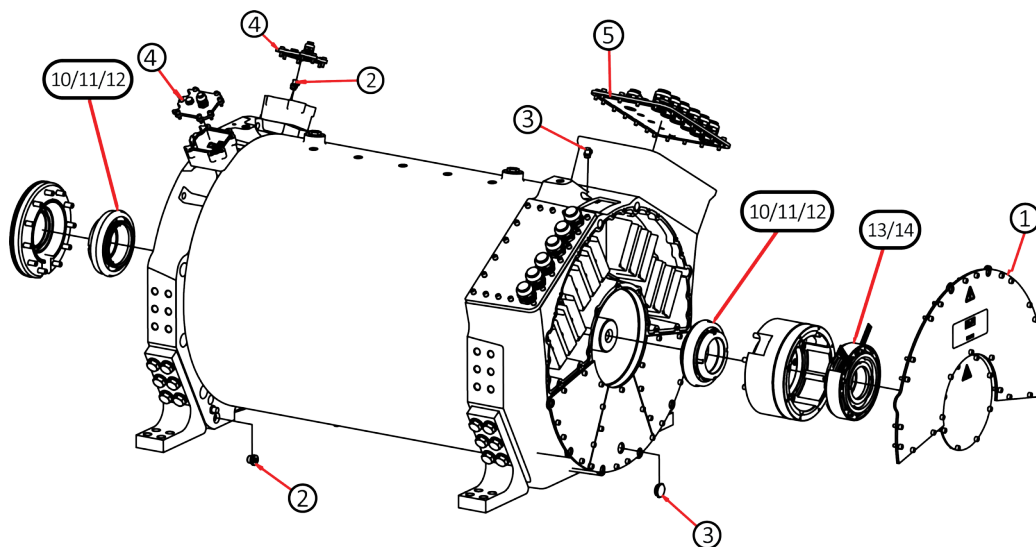
**Service part kits for EM-PMI540B-T3000 / T4000**

Position	Kit name	Description	Order number
1	HV terminal box cover	Replacement seals/bolts	11333593
2	Plugs D-end	Replacement plug/seal	11334553
3	Plugs, N-end	Replacement plug/seal	11334535
4	LV terminal box cover, D-end (with +LVB1)	Replacement seals/bolts	11333587
5	LV terminal box cover, N-end (with +LVB1)	Replacement seals/bolts	11333592 (*)
10	Bearing kit, non-insulated	Bearing replacement kit	11334512
11	Bearing kit, insulated bearing in N-end (+BIN)	Bearing replacement kit	11334545
12	Bearing kit, insulated bearing in both ends (+BIA)	Bearing replacement kit	11334534
13	Resolver (+RES1)	Resolver replacement kit	11334562
14	Double resolver (+RES2)	Resolver replacement kit	11334561

(\* Correct kit needs to be specified according to machine options.

## Disposal

Dispose of the electric machine and any of its parts by appropriate means in accordance with local laws and regulations.

## Storage, installation and maintenance checklists

### Electric machine installation checklist

Date:

#### Electric machine and customer information

<b>Customer:</b>	<b>Electric machine type (from the rating plate):</b>
<b>Customer reference:</b>	<b>Electric machine serial number:</b>
<b>Service reference:</b>	<b>Date installed:</b>

N.A = Procedure not applicable PASS = Procedure passed FAIL = Procedure failed

#### Installation checklist

	Approval	N.A	PASS	FAIL
<b>General</b>				
Electric machine type is correct		<input type="checkbox"/>	<input type="checkbox"/>	<input type="checkbox"/>
Electric machine is undamaged		<input type="checkbox"/>	<input type="checkbox"/>	<input type="checkbox"/>
Insulation resistance check For more information, see <a href="#">Insulation resistance test</a> on page 31.	Reference value of 500 MΩ must be exceeded at reference ambient temperature 25°C (measured with 500 V <sub>DC</sub> / 1 min insulation resistance test).	<input type="checkbox"/>	<input type="checkbox"/>	<input type="checkbox"/>
Environmental conditions as specified (see data sheet)		<input type="checkbox"/>	<input type="checkbox"/>	<input type="checkbox"/>
<b>Mechanical installation</b>				
Supporting structure as required		<input type="checkbox"/>	<input type="checkbox"/>	<input type="checkbox"/>
Shaft alignment as specified (see chapter Shaft alignment and load).		<input type="checkbox"/>	<input type="checkbox"/>	<input type="checkbox"/>
Cooling circuit connected and coolant flowing		<input type="checkbox"/>	<input type="checkbox"/>	<input type="checkbox"/>
<b>Used coolant:</b>				
<b>Power connections</b>				
Cable gland assembly as specified (cable gland to cables) with correct cable diameter		<input type="checkbox"/>	<input type="checkbox"/>	<input type="checkbox"/>
Cable lug air cap (to metallic structures)	≥10 mm	<input type="checkbox"/>	<input type="checkbox"/>	<input type="checkbox"/>
Cable lug tightening torque (to the bus bar)		<input type="checkbox"/>	<input type="checkbox"/>	<input type="checkbox"/>
Connection box cover bolts tightening torque		<input type="checkbox"/>	<input type="checkbox"/>	<input type="checkbox"/>
<b>Grounding</b>				
Electric machine enclosure grounding connected		<input type="checkbox"/>	<input type="checkbox"/>	<input type="checkbox"/>
Low voltage cable shield grounding connected		<input type="checkbox"/>	<input type="checkbox"/>	<input type="checkbox"/>
Power cable shield connection resistances to ground (electric machine enclosure) measured and valid		<input type="checkbox"/>	<input type="checkbox"/>	<input type="checkbox"/>

*Installation checklist (continued)*

	Approval	N.A	PASS	FAIL
Low voltage cable shield grounding resistances measured and valid		<input type="checkbox"/>	<input type="checkbox"/>	<input type="checkbox"/>
<b>Notes:</b> <ul style="list-style-type: none"> <li>•</li> <li>•</li> <li>•</li> <li>•</li> <li>•</li> <li>•</li> <li>•</li> <li>•</li> <li>•</li> <li>•</li> <li>•</li> <li>•</li> <li>•</li> </ul> <b>Date:</b> <b>Signature:</b>				

Do not try to tighten bolts or screws that are not discussed in the product manual and that are not needed for the normal installation procedures. Sealing of the screws may break.

**Electric machine weekly maintenance checklist**

**Date:**

*Electric machine and customer information*

<b>Customer:</b>	<b>Electric machine type (from the rating plate):</b>
<b>Customer reference:</b>	<b>Electric machine serial number:</b>
<b>Service reference:</b>	<b>Date installed:</b>

N.A = Procedure not applicable PASS = Procedure passed FAIL = Procedure failed

*Electric machine weekly maintenance checklist*

	N.A	PASS	FAIL
<b>General construction</b>			
Noise or vibration during operation in general	<input type="checkbox"/>	<input type="checkbox"/>	<input type="checkbox"/>
<b>Cooling system</b>			
Functioning of the cooling system in general	<input type="checkbox"/>	<input type="checkbox"/>	<input type="checkbox"/>
<b>Notes:</b> <ul style="list-style-type: none"> <li>•</li> <li>•</li> <li>•</li> <li>•</li> <li>•</li> <li>•</li> <li>•</li> <li>•</li> <li>•</li> <li>•</li> <li>•</li> <li>•</li> <li>•</li> </ul>			

**Electric machine monthly maintenance checklist**

**Date:**

*Electric machine and customer information*

<b>Customer:</b>	<b>Electric machine type (from the rating plate):</b>
<b>Customer reference:</b>	<b>Electric machine serial number:</b>
<b>Service reference:</b>	<b>Date installed:</b>

N.A = Procedure not applicable PASS = Procedure passed FAIL = Procedure failed

*Electric machine monthly maintenance checklist*

	N.A	PASS	FAIL
<b>General construction</b>			
Noise or vibration during operation in general	<input type="checkbox"/>	<input type="checkbox"/>	<input type="checkbox"/>
Cleanliness of the enclosure and connected parts	<input type="checkbox"/>	<input type="checkbox"/>	<input type="checkbox"/>
<b>Electrical system</b>			
Weariness of the cables	<input type="checkbox"/>	<input type="checkbox"/>	<input type="checkbox"/>
Insulation monitoring	Continuous insulation monitoring. (It is recommended to use continuous insulation monitoring for the whole system where electric machine is used.)		
Encoder mounting	<input type="checkbox"/>	<input type="checkbox"/>	<input type="checkbox"/>
<b>Cooling system</b>			
Functioning of the cooling system in general	<input type="checkbox"/>	<input type="checkbox"/>	<input type="checkbox"/>
Tightness of the ventilation plug	<input type="checkbox"/>	<input type="checkbox"/>	<input type="checkbox"/>
Cleanliness of the ventilation plug	<input type="checkbox"/>	<input type="checkbox"/>	<input type="checkbox"/>
<b>Notes:</b>			
<ul style="list-style-type: none"> <li>•</li> <li>•</li> <li>•</li> <li>•</li> <li>•</li> <li>•</li> <li>•</li> <li>•</li> <li>•</li> <li>•</li> <li>•</li> <li>•</li> <li>•</li> <li>•</li> <li>•</li> </ul>			

**Electric machine yearly maintenance checklist**

**Date:**

*Electric machine and customer information*

<b>Customer:</b>	<b>Electric machine type (from the rating plate):</b>
<b>Customer reference:</b>	<b>Electric machine serial number:</b>
<b>Service reference:</b>	<b>Date installed:</b>

N.A = Procedure not applicable PASS = Procedure passed FAIL = Procedure failed

*Electric machine yearly maintenance checklist*

	Acceptance	N.A	PASS	FAIL
<b>General construction</b>				
Noise or vibration during operation in general		<input type="checkbox"/>	<input type="checkbox"/>	<input type="checkbox"/>

*Electric machine yearly maintenance checklist (continued)*

	Acceptance	N.A	PASS	FAIL
<b>Mounting bolt tightness</b>				
Cleanliness of the enclosure and connected parts		<input type="checkbox"/>	<input type="checkbox"/>	<input type="checkbox"/>
<b>Electrical system</b>				
Weariness of the cables		<input type="checkbox"/>	<input type="checkbox"/>	<input type="checkbox"/>
Electrical connections in general		<input type="checkbox"/>	<input type="checkbox"/>	<input type="checkbox"/>
Cable lug tightening torque (to the bus bar)		<input type="checkbox"/>	<input type="checkbox"/>	<input type="checkbox"/>
Connection box cover bolts tightening torque		<input type="checkbox"/>	<input type="checkbox"/>	<input type="checkbox"/>
<b>Cooling system</b>				
Coolant quality as specified		<input type="checkbox"/>	<input type="checkbox"/>	<input type="checkbox"/>
Used coolant:				
Functioning of the cooling system in general		<input type="checkbox"/>	<input type="checkbox"/>	<input type="checkbox"/>
Tightness of the tubing and connections (no leakages)		<input type="checkbox"/>	<input type="checkbox"/>	<input type="checkbox"/>
Cleanliness of the ventilation plug		<input type="checkbox"/>	<input type="checkbox"/>	<input type="checkbox"/>
<b>Grounding</b>				
Power cable shield connection resistances to ground (electric machine enclosure) checked		<input type="checkbox"/>	<input type="checkbox"/>	<input type="checkbox"/>
Low voltage cable shield grounding resistances checked		<input type="checkbox"/>	<input type="checkbox"/>	<input type="checkbox"/>
Connection to grounding points checked		<input type="checkbox"/>	<input type="checkbox"/>	<input type="checkbox"/>
Notes:				
<ul style="list-style-type: none"> <li>•</li> <li>•</li> <li>•</li> <li>•</li> <li>•</li> <li>•</li> <li>•</li> <li>•</li> <li>•</li> <li>•</li> <li>•</li> <li>•</li> <li>•</li> <li>•</li> </ul>				

Do not try to tighten bolts or screws that are not discussed in the product manual and that are not needed for the normal installation procedures. Sealing of the screws may break.

For cleaning instructions, refer to Chapter *Cleaning* on page 74.

*Used service parts*

Part description	Part type	Quantity	Item (order) number
–			
–			
–			
–			

*Used service parts (continued)*

Part description	Part type	Quantity	Item (order) number
–			
<b>Notes:</b> <ul style="list-style-type: none"> <li>•</li> <li>•</li> <li>•</li> <li>•</li> <li>•</li> <li>•</li> <li>•</li> <li>•</li> <li>•</li> <li>•</li> <li>•</li> <li>•</li> <li>•</li> </ul> <b>Date:</b> <b>Signature:</b>			

**Electric machine storage checklist****Date:***Electric machine and customer information*

<b>Customer:</b>	<b>Electric machine type (from the rating plate):</b>
<b>Customer reference:</b>	<b>Electric machine serial number:</b>
<b>Service reference:</b>	<b>Date installed:</b>

This storage checklist is used when storing the electric machine. Regular inspection is required. See specifications for storage in this User Guide or in the Data Sheet.

Fill in the date of each inspection to the Table below.

*Storage checklist*

Procedure	Date	Date	Date	Date	Date
Storage base as specified (vibration free)					
Storage temperature and humidity as specified					
Electric machine type and serial number is correct					
Electric machine supported correctly					
Corrosion protection of non-painted surfaces (for example shaft-end and grounding points)					
Insulation resistance (test insulation resistance every three months in storage)					
Shaft rotated as specified (10 rotations monthly)					



**Hydro-Gear**

www.hydro-gear.com

**Daikin-Sauer-Danfoss**

www.daikin-sauer-danfoss.com

Explore our solutions at [danfoss.com](http://danfoss.com).

Additional product literature is available at [powersource.danfoss.com](http://powersource.danfoss.com).

**Danfoss  
Power Solutions (US) Company**  
2800 East 13th Street  
Ames, IA 50010, USA  
Phone: +1 515 239 6000

**Danfoss  
Power Solutions GmbH & Co. OHG**  
Krokamp 35  
D-24539 Neumünster, Germany  
Phone: +49 4321 871 0

**Danfoss  
Power Solutions ApS**  
Nordborgvej 81  
DK-6430 Nordborg, Denmark  
Phone: +45 7488 2222

**Danfoss  
Power Solutions Trading  
(Shanghai) Co., Ltd.**  
Building #22, No. 1000 Jin Hai Rd  
Jin Qiao, Pudong New District  
Shanghai, China 201206  
Phone: +86 21 2080 6201

---

Danfoss can accept no responsibility for possible errors in catalogues, brochures and other printed material. Danfoss reserves the right to alter its products without notice. This also applies to products already on order provided that such alterations can be made without subsequent changes being necessary in specifications already agreed.  
All trademarks in this material are property of the respective companies. Danfoss and the Danfoss logotype are trademarks of Danfoss A/S. All rights reserved.

---