



Motor / Generator

EM-PMI375



Revision history

Table of revisions

| Date | Changed | Rev |
|----------------|---|------------|
| April 2026 | Sections updated: Product naming convention, Low voltage connections | 0210 |
| August 2025 | Sections updated: Product naming convention, Operation conditions | 0209 |
| March 2025 | Sections updated: Product naming convention, Low voltage connections | 0208 |
| October 2024 | Section updated: Grounding connections | 0207 |
| September 2024 | Sections updated: Product naming convention, Installation, Service parts | 0206 |
| May 2024 | Sections updated: Shaft alignment and load, Storage, Condition monitoring during operation, Service parts | 0205 |
| April 2023 | Minor modifications and improvements | 0204 |

General information

| | |
|---|----|
| Intended use of the user guide..... | 5 |
| Product naming convention | 5 |
| Conformity according to standards..... | 10 |
| Warranty..... | 10 |
| Terms and abbreviations..... | 11 |
| Responsibility of the manufacturer..... | 11 |

Safety information

| | |
|--|----|
| General safety statement..... | 12 |
| Safety message signal words..... | 12 |
| Safety symbols..... | 12 |
| Personal protective equipment..... | 13 |
| Safety features..... | 13 |
| Electromagnetic compatibility (EMC)..... | 13 |

Product overview

| | |
|---|----|
| Intended use of the electric machine..... | 16 |
| Used technology..... | 17 |
| System introduction..... | 17 |
| Connections and interfaces..... | 18 |
| Rating plate..... | 19 |
| Tightening torques..... | 21 |

Design principles

| | |
|---|----|
| System design..... | 22 |
| Cooling and temperature measurement | 22 |
| Insulation lifetime..... | 22 |
| Inverter..... | 22 |
| Mounting structure..... | 24 |
| Supporting structure requirements..... | 24 |
| Shaft alignment and load..... | 24 |

Transportation and storage

| | |
|------------------------------|----|
| Transportation..... | 27 |
| Receiving and unpacking..... | 27 |
| Lifting..... | 27 |
| Storage..... | 28 |
| Extended storage..... | 29 |

Installation

| | |
|---|----|
| Required tools..... | 30 |
| Insulation resistance test..... | 30 |
| Mechanical installation..... | 32 |
| Allowed mounting positions..... | 32 |
| Mounting the electric machine..... | 34 |
| Cooling connections..... | 36 |
| Electrical installation..... | 36 |
| Power connections..... | 36 |
| High voltage connection..... | 36 |
| Connection diagram..... | 38 |
| Cable gland assembly and power line connection..... | 38 |
| Low voltage connections..... | 44 |
| Grounding connections..... | 49 |
| Anti-condensation heater connections..... | 51 |

Operation

| | |
|--|----|
| Operation conditions..... | 52 |
| Condition monitoring during operation..... | 53 |
| Recommended lubricants..... | 53 |
| Recommended coolants..... | 53 |
| Emergency operation..... | 53 |

Maintenance

| | |
|--------------------------|----|
| Regular maintenance..... | 55 |
| Cleaning..... | 56 |

| | |
|---------------------------------|----|
| Bearings and lubrication..... | 57 |
| Cooling system maintenance..... | 60 |

Dismounting

Troubleshooting

Aftersales

| | |
|---------------------|----|
| Service policy..... | 64 |
| Service parts..... | 64 |

Disposal

Storage, installation and maintenance checklists

General information

This user guide is the installation, operation and maintenance user guide for the EM-PMI375-T200, EM-PMI375-T500, EM-PMI375-T800 and EM-PMI375-T1100 electric machines.

Intended use of the user guide

This user guide provides essential instructions for the safe handling, installation, operation, and maintenance of the electric machine. It is crucial reading for all personnel involved in the installation, operation, or maintenance of the machine and associated equipment.

Strict adherence to all safety warnings and instructions in this user guide is mandatory to prevent personal injury and property damage. Only qualified and authorized personnel, possessing knowledge of relevant health and safety regulations and national legislation, are permitted to handle, install, operate, and maintain the electric machine.

Illustrations in this user guide are examples and may not depict all system features.

Retain this user guide for future reference during installation, operation, and maintenance.

Product naming convention

In this user guide, EM-PMI family permanent magnet motors and generators are referred to as the electric machine.

Frame model indicates dimensions and electrical characteristics of the electric machine. The following naming convention is used to refer to the electric machine frame model:

- EM-PMI375-T200-XXXX+XX
- EM-PMI375-T500-XXXX+XX
- EM-PMI375-T800-XXXX+XX
- EM-PMI375-T1100-XXXX+XX

The naming codes of the electric machine

| Part of the name | Meaning |
|------------------|---|
| EM | Electric Machine |
| PMIXXX or PMEXXX | Permanent Magnet Internal and a number relative to the diameter of the electric machine, or Permanent Magnet External and a number relative to diameter of the electric machine |
| TXXXX | Average continuous torque of the motor range, relative to the length of the machine |
| XXXX | Rated rotation speed |
| +XX | Options. Standard options are indicated by a star (*). |

The power input of the machine may require one or several three phase power systems. This is indicated by a power connection option marking, for example: DUAL or QUAD in the machine model code. One three phases power system can include one or three connection boxes in the machine. The most usual case is when an electric machine has a single connection box, but this is not shown in the machine model code.

- Example: EM-PMI375-T800-1300-DUAL

The electric machine can include some of the options available. The options of the electric machine are shown also in the rating plate, following the frame model code. Note! Only options that differ from the standard delivery are indicated. For detailed information on the models, options and characteristics, see product-specific data sheet.

EM-PMI375-T200 options

| Variant | Code | Description | Additional information |
|--|--------|---|--|
| Low voltage connections | * | Low voltage connections done with connector | DEUTSCH HD34-24-47PE connector for LV connections |
| | +LVB1 | Low voltage connections done with connection box and terminal strip | Connection box with 3 x M25, 1 x M20 cable glands (reserve/plugged 1 x M16) and terminal block for LV connections. |
| N-end attachment | * | Flange | SAE 4 flywheel housing |
| | +NE2 | Male shaft + Flange | DIN5480 W50x2x24x8f + SAE 4 flywheel housing |
| Bearing lubrication and mounting direction | * | Greased for life | Deep groove ball bearing, contact seal on both sides, any mounting direction |
| | +BHS | Grease lubricated | Deep groove ball bearing, open design, horizontal mounting direction |
| Bearing insulation | * | Non-insulated bearings | Non-insulated bearings |
| | +BIN | Insulated bearing in N-end | Insulated bearing in N-end |
| | +BIA | Insulated bearing in both ends | Insulated bearing in both ends |
| Shaft grounding | * | None | |
| | +SG1 | D-end shaft grounding | Inbuilt grounding ring |
| Protection class | * | Standard protection class | IP65 protection class |
| | +IP67 | IP67 protection class | IP67 protection class (not available with +BHS option) |
| Cable direction | * | Cable direction fixed | Cable direction towards D-end |
| | +CNE | Cable direction towards N-end | Cable direction towards N-end |
| Rotation sensor | * | None | |
| | +RES1 | Resolver | Inbuilt non-contacting resolver, 6-pole pair |
| Side mounting | * | None | No side mounting holes available. In case side mounting holes are present, they are plugged by default. |
| | +SM1 | Side mounting | 12 x side mounting threaded holes M10x1.5. Plugged by default with M10x10, DIN 913, (ISO 4026), set screw |
| Winding temperature sensors | * | Temperature surveillance | 3 x PT100 (two-wire) in windings |
| | +TEMP4 | Redundant temperature surveillance | 6 x PT100 (two-wire) in windings |
| Bearing temperature sensors | * | None | |
| | +BTMP1 | PT100 in bearings | Plug-in connector |
| Anti-condensation heaters | * | None | |
| | +HEAT1 | One anti-condensation heater | 230 V _{AC} / 65 W |
| Marine classification | * | No marine classification | |
| | +CL1 | | ABS American Bureau of Shipping |
| | +CL2 | | BV Bureau Veritas |
| | +CL3 | | DNV |
| | +CL4 | | LR Lloyd's Register |
| | +CL5 | | RINA |
| | +CL6 | | CCS China Classification Society |

EM-PMI375-T500 options

| Variant | Code | Description | Additional information |
|--|--------|---|--|
| High voltage connections | * | One three-phase system | One connection box containing one three-phase system with one M25 cable gland per phase, total of 3 pcs M25 cable glands |
| | -DUAL | Two galvanically isolated three-phase systems | Two connection boxes each containing one three-phase system with one M25 cable gland per phase, total of 6 pcs M25 cable glands Available only for speed variant 3200 rpm |
| Low voltage connections | * | Low voltage connections done with connector | DEUTSCH HD34-24-47PE connector for LV connections |
| | +LVB1 | Low voltage connections done with connection box and terminal strip | Connection box with 3 x M25, 1 x M20 cable glands (reserve/plugged 1 x M16) and terminal block for LV connections. |
| N-end attachment | * | Flange | SAE 4 flywheel housing |
| | +NE2 | Male shaft + flange | DIN5480 W50x2x24x8f + SAE 4 flywheel housing |
| Bearing lubrication and mounting direction | * | Greased for life | Deep groove ball bearing, contact seal on both sides, any mounting direction |
| | +BHS | Grease lubricated | Deep groove ball bearing, open design, horizontal mounting direction |
| Bearing insulation | * | Non-insulated bearings | Non-insulated bearings |
| | +BIN | Insulated bearing in N-end | Insulated bearing in N-end |
| | +BIA | Insulated bearing in both ends | Insulated bearing in both ends |
| Shaft grounding | * | None | |
| | +SG1 | D-end shaft grounding | Inbuilt grounding ring |
| Protection class | * | Standard protection class | IP65 protection class |
| | +IP67 | IP67 protection class | IP67 protection class (not available with +BHS option) |
| Cable direction | * | Cable direction fixed | Cable direction towards D-end |
| | +CNE | Cable direction towards N-end | Cable direction towards N-end |
| Rotation sensor | * | None | |
| | +RES1 | Resolver | Inbuilt non-contacting resolver, 6-pole pair |
| Side mounting | * | None | No side mounting holes available. In case side mounting holes are present, they are plugged by default. |
| | +SM1 | Side mounting | 12 x side mounting threaded holes M10x1.5. Plugged by default with M10x10, DIN 913, (ISO 4026), set screw |
| Winding temperature sensors | * | Temperature surveillance | 3 x PT100 (two-wire) in windings |
| | +TEMP4 | Redundant temperature surveillance | 6 x PT100 (two-wire) in windings |
| | +TEMP5 | Redundant temperature surveillance | 12 x PT100 (two-wire) in windings |
| Bearing temperature sensor | * | None | |
| | +BTMP1 | PT100 in bearings | Plug-in connector |
| Anti-condensation heaters | * | None | |
| | +HEAT1 | One anti-condensation heater | 230 V _{AC} / 65 W |

EM-PMI375-T500 options (continued)

| Variant | Code | Description | Additional information |
|-----------------------|------|--------------------------|----------------------------------|
| Marine classification | * | No marine classification | |
| | +CL1 | | ABS American Bureau of Shipping |
| | +CL2 | | BV Bureau Veritas |
| | +CL3 | | DNV |
| | +CL4 | | LR Lloyd's Register |
| | +CL5 | | RINA |
| | +CL6 | | CCS China Classification Society |

EM-PMI375-T800 options

| Variant | Code | Description | Additional information |
|--|-------|---|---|
| High voltage connections | * | One three-phase system | One connection box containing one three-phase system with one M25 cable gland per phase, total of 3 pcs M25 cable glands |
| | -DUAL | Two galvanically isolated three-phase systems | Two connection boxes each containing one three-phase system with one M25 cable gland per phase, total of 6 pcs M25 cable glands Available for speed variants 1600, 1900, 2300, 2800, 3200 and 3800 rpm |
| Low voltage connections | * | Low voltage connections done with connector | DEUTSCH HD34-24-47PE connector for LV connections |
| | +LVB1 | Low voltage connections done with connection box and terminal strip | Connection box with 3 x M25, 1 x M20 cable glands (reserve/plugged 1 x M16) and terminal block for LV connections. |
| N-end attachment | * | Flange | SAE 4 flywheel housing |
| | +NE2 | Male shaft + Flange | DIN5480 W50x2x24x8f + SAE 4 flywheel housing |
| Bearing lubrication and mounting direction | * | Greased for life | Deep groove ball bearing, contact seal on both sides, any mounting direction |
| | +BHS | Grease lubricated | Deep groove ball bearing, open design, horizontal mounting direction |
| Bearing insulation | * | Non-insulated bearings | Non-insulated bearings |
| | +BIN | Insulated bearing in N-end | Insulated bearing in N-end |
| | +BIA | Insulated bearing in both ends | Insulated bearing in both ends |
| Shaft grounding | * | None | |
| | +SG1 | D-end shaft grounding | Inbuilt grounding ring |
| Protection class | * | Standard protection class | IP65 protection class |
| | +IP67 | IP67 protection class | IP67 protection class (not available with +BHS option) |
| Cable direction | * | Cable direction fixed | Cable direction towards D-end |
| | +CNE | Cable direction towards N-end | Cable direction towards N-end |
| Rotation sensor | * | None | |
| | +RES1 | Resolver | Inbuilt non-contacting resolver, 6-pole pair |
| Side mounting | * | None | No side mounting holes available. In case side mounting holes are present, they are plugged by default. |
| | +SM1 | Side mounting | 12 x side mounting threaded holes M10x1.5. Plugged by default with M10x10, DIN 913, (ISO 4026), set screw |

EM-PMI375-T800 options (continued)

| Variant | Code | Description | Additional information |
|-----------------------------|--------|------------------------------------|-----------------------------------|
| Winding temperature sensor | * | Temperature surveillance | 3 x PT100 (two-wire) in windings |
| | +TEMP4 | Redundant temperature surveillance | 6 x PT100 (two-wire) in windings |
| | +TEMP5 | Redundant temperature surveillance | 12 x PT100 (two-wire) in windings |
| Bearing temperature sensors | * | None | |
| | +BTMP1 | PT100 in bearings | Plug-in connector |
| Anti-condensation heaters | * | None | |
| | +HEAT1 | One anti-condensation heater | 230 V _{AC} / 65 W |
| Marine classification | * | No marine classification | |
| | +CL1 | | ABS American Bureau of Shipping |
| | +CL2 | | BV Bureau Veritas |
| | +CL3 | | DNV |
| | +CL4 | | LR Lloyd's Register |
| | +CL5 | | RINA |
| | +CL6 | | CCS China Classification Society |

EM-PMI375-T1100 options

| Variant | Code | Description | Additional information |
|--|-------|---|---|
| High voltage connections | * | One three-phase system | One connection box containing one three-phase system with one M25 cable gland per phase, total of 3 pcs M25 cable glands |
| | -DUAL | Two galvanically isolated three-phase systems | Two connection boxes each containing one three-phase system with one M25 cable gland per phase, total of 6 pcs M25 cable glands |
| Low voltage connections | * | Low voltage connections done with connector | DEUTSCH HD34-24-47PE connector for LV connections |
| | +LVB1 | Low voltage connections done with connection box and terminal strip | Connection box with 3 x M25, 1 x M20 cable glands (reserve/plugged 1 x M16) and terminal block for LV connections. |
| N-end attachment | * | Flange | SAE 4 flywheel housing |
| | +NE2 | Male shaft + Flange | DIN5480 W55x2x26x8a + SAE 4 flywheel housing |
| Bearing lubrication and mounting direction | * | Grease lubricated | Deep groove ball bearing, open design, horizontal mounting direction. |
| | +BGL | Greased for life | Deep groove ball bearing, contact seal on both sides, any mounting direction Maximum speed 3400 rpm |
| Bearing insulation | * | Non-insulated bearings | Non-insulated bearings |
| | +BIN | Insulated bearing in N-end | Insulated bearing in N-end |
| | +BIA | Insulated bearing in both ends | Insulated bearing in both ends |
| Shaft grounding | * | None | |
| | +SG1 | D-end shaft grounding | Inbuilt grounding ring |
| Protection class | * | Standard protection class | IP65 protection class |
| | +IP67 | IP67 protection class | IP67 protection class (only available with +BGL) |
| Cable direction | * | Cable direction fixed | Cable direction towards D-end |
| | +CNE | Cable direction towards N-end | Cable direction towards N-end |
| Rotation sensor | * | None | |
| | +RES1 | Resolver | Inbuilt non-contacting resolver, 6-pole pair |

EM-PMI375-T1100 options (continued)

| Variant | Code | Description | Additional information |
|----------------------------|--------|------------------------------------|---|
| Side mounting | * | None | No side mounting holes available. In case side mounting holes are present, they are plugged by default. |
| | +SM1 | Side mounting | 12 x side mounting threaded holes M10x1.5. Plugged by default with M10x10, DIN 913, (ISO 4026), set screw |
| Winding temperature sensor | * | Temperature surveillance | 3 x PT100 (two-wire) in the windings |
| | +TEMP4 | Redundant temperature surveillance | 6 x PT100 (two-wire) in the windings |
| | +TEMP5 | Redundant temperature surveillance | 12 x PT100 (two-wire) in windings |
| Bearing temperature sensor | * | None | |
| | +BTMP1 | PT100 in bearings | Plug-in connector |
| Anti-condensation heaters | * | None | |
| | +HEAT1 | One anti-condensation heater | 230 V _{AC} / 130 W |
| Marine classification | * | No marine classification | |
| | +CL1 | | ABS American Bureau of Shipping |
| | +CL2 | | BV Bureau Veritas |
| | +CL3 | | DNV |
| | +CL4 | | LR Lloyd's Register |
| | +CL5 | | RINA |
| | +CL6 | | CCS China Classification Society |

Conformity according to standards

The electric machine has been designed to be in conformity with the following directives and to meet the requirements specified in the following standards:

Applicable directives and standards

| Standard | Explanation |
|--|---|
| Low Voltage Directive 2006/95/EC (until 19.4.2016) and Low Voltage Directive 2014/35/EU (from 20.4.2016 onwards) | Electrical equipment means any equipment designed for use with a voltage rating of between 50 and 1000 V for alternating current. This electric machine is subject to the Low Voltage Directive 2006/95/EC or 2014/35/EC. |
| IEC 60034-1:2010 | Rotating electrical machines - Part 1: Rating and performance |
| IEC 60034-5:2001/A1:2007 | Rotating electrical machines - Part 5: Degrees of protection provided by the integral design of rotating electrical machines (IP code) - Classification |
| IEC 60034-6:1991 | Rotating electrical machines - Part 6: Methods of cooling |
| IEC 60034-7:1992/A1:2001 | Rotating electrical machines - Part 7: Classification of types of construction, mounting arrangements and connection box position (IM Code) |
| IEC 60034-8:2007/A1:2014 | Rotating electrical machines - Part 8: Terminal markings and direction of rotation |
| IEC 60034-14:2004/A1:2008 | Amendment 1 - Rotating electrical machines - Part 14: Mechanical vibration of certain machines with shaft heights 56 mm and higher - Measurement, evaluation and limits of vibration severity. |

It should be noted, that the commissioning party is responsible for establishing the conformity of the end product with the Directive 2006/42/EC, when the EM-PMI electric machines are fitted into machinery.

Warranty

Danfoss offers warranty against defects in workmanship and materials for its products. For more information, see General terms and conditions of sale at <https://www.danfoss.com/en/terms/sales-conditions/>.

Warranty validity requires adherence to the instructions in this document and all related materials, including product installation and maintenance guidelines, and compliance with all applicable national standards and regulations.

The warranty does not cover defects resulting from improper or negligent use, operation, or installation; failure to perform regular preventive maintenance; or damage caused by external factors or the use of non-Danfoss supplied/recommended equipment and components.

Any unauthorized repairs or modifications made without Danfoss' prior written consent will invalidate the warranty.

Terms and abbreviations

The following tables define symbols, terms, and abbreviations that may appear in this user guide.

Symbols

| Symbol | Variable | Unit |
|------------------|--|------------------|
| U | Rated voltage (phase-to-phase AC) | V _{rms} |
| I | Rated current (AC) | A _{rms} |
| P | Rated Power (S1) | kW |
| T | Rated torque (S1) at rated speed | Nm |
| T _{max} | Maximum torque | Nm |
| n | Rated speed | rpm |
| Max n | Maximum speed | rpm |
| f | Rated supply frequency at nominal speed | Hz |
| PF | Power factor (cosφ) | |
| Q _c | Rated coolant liquid flow | l/min |
| T _c | Rated coolant liquid input temperature | °C |
| T _{amb} | Rated ambient temperature | °C |
| RES_COS | Cosine signal received from the resolver | deg |
| RES_SIN | Sinusoidal signal received from the resolver | deg |
| Ω (Ohm) | Resistance | Ω |

Terms and abbreviations

| Term / abbreviation | Explanation |
|---------------------|---|
| Resolver | Rotation meter in electric machines, used for measuring degrees of rotation |
| AC | Alternating current |
| DC | Direct current |
| GND | Ground in electrical connections |
| PMSM | Permanent Magnet Synchronous Machine |
| SRPM | Synchronous Reluctance assisted Permanent Magnet |
| S1 | Duty type according to the IEC60034; Continuous running duty |
| S9 | Duty type according to the IEC60034; Duty with non-periodic load and speed variations |

Responsibility of the manufacturer

Danfoss guarantees the safety, reliability, and performance of the electric machine only when the following conditions are met:

- Handling, mounting, installation, operation, and maintenance are performed by qualified and authorized personnel.
- The system installation adheres to all applicable regulations.
- The electric machine is operated according to the instructions in this user guide.
- The electric machine is installed, maintained, and serviced according to the instructions in this user guide.

Safety information

General safety statement

- Designed for use as a component in industrial and commercial installations, the electric machine requires that the end product comply with all relevant regulations.
- The electric machine cannot be used in hazardous areas unless specifically designed for that purpose.
- Only qualified personnel familiar with health and safety requirements and national legislation should install, use, and maintain this electric machine. Failure to comply with these instructions may void all applicable warranties.
- These instructions are essential for the safe and correct installation, operation, and maintenance of the electric machine. Make sure everyone who installs, operates, or maintains the electric machine or related equipment has access to and understands these instructions.
- This user guide covers electric machines with high voltage and rotating parts that can cause serious or fatal injuries. To prevent injury, always follow safety precautions.

Safety message signal words

Safety message signal words indicate the severity of a potential hazard.

DANGER Indicates an imminently hazardous situation which, if not avoided, will result in death or serious injury.









WARNING Indicates a potentially hazardous situation which, if not avoided, could result in death or serious injury.

CAUTION Indicates a potentially hazardous situation which, if not avoided, may result in minor or moderate injury. CAUTION may also alert against unsafe practices.

NOTICE Indicates a potentially hazardous situation which, if not avoided, could result in property damage.





Safety symbols

The following safety and information symbols are used in this user guide and on the electric machine.

| | |
|---|--|
|  | Danger This symbol warns of a dangerous situation that could result in serious injury or death. Do not perform the action indicated by this symbol. |
|  | General warning This symbol indicates a potentially hazardous situation. |
|  | Electric shock warning This symbol indicates the presence of dangerous voltage that could cause electric shock. |
|  | Burn warning This symbol warns of a hot surface that could cause burns. The device should be installed to prevent contact with its potentially hot surfaces. |
|  | Magnet warning This symbol warns of a strong magnetic field that could be harmful to people or property. |
|  | Rotating shaft warning This symbol warns of a strong rotating shaft that could be harmful to people or property. |
|  | This symbol indicates that the following content is for general information. |
|  | This symbol indicates that you need to refer to the user guide for instructions. |

Personal protective equipment



To prevent injury during handling, installation, and maintenance of the electric machine, use appropriate personal protective equipment when necessary.

| | |
|---|---|
|  | Wear safety goggles or a mask when working on the electric machine. Bearing grease, melted nitrile rubber (from the radial lip seal), glycol, or other fluids could splash and cause permanent eye damage. |
|  | Wear hearing protection when working on the electric machine. Exposure to noise levels above 85 dBA can cause hearing damage. |
|  | Wear a helmet when lifting the electric machine to protect yourself from potential head injuries caused by falling objects. |
|  | Wear cut-resistant gloves when handling and maintaining the electric machine to protect against cuts. |
|  | Wear protective footwear when lifting or moving the electric machine to prevent foot injuries in case of lifting system or bracket failure. |

Safety features

The electric machine has at least one PT100 temperature sensor in the windings. The amount of the sensors depends on the options chosen. The temperature signal(s) can be read out from the measurement connector of the electric machine. You can connect the temperature signal to the temperature surveillance pin in the inverter (EC-C) and make sure that the inverter has the machine temperature protection feature activated.

Electromagnetic compatibility (EMC)

| | |
|---|--|
|  | When connecting to other equipment, ensure that only specified and compatible components of the system are used. |
|  | <p>Individuals with heart pacemakers, metal implants, or hearing aids should be aware that electric machines generate magnetic and electromagnetic fields that can be a health hazard. These individuals should consult a doctor due to the risks posed by current-carrying conductors and permanent magnets before entering the following areas:</p> <ul style="list-style-type: none"> • Areas where electrical equipment and parts are operating • Areas where electrical equipment with permanent magnets is stored, assembled, operated, or repaired <p>If necessary, perform a dedicated EMC test on the installation.</p> |

Electromagnetic compatibility (EMC) is the ability of electrical equipment to function correctly in its electromagnetic environment without causing interference to other devices. Meeting EMC requirements is a legal obligation for all equipment used within the European Economic Area (EEA)

Our products are designed with high standards of EMC in mind. Connect the power cables and groundings along the instructions in this user guide to achieve the required level of electromagnetic interference (EMI) shielding.

The installer is responsible for ensuring that the equipment or system into which this product is integrated complies with the EMC legislation of the country where it will be used. Within the European Union, equipment incorporating this product must comply with the EMC Directive 2014/30/EU.

Product overview



This user guide covers the following electric machines:

- **EM-PMI375-T200**
- **EM-PMI375-T500**
- **EM-PMI375-T800**
- **EM-PMI375-T1100**

These electric machines are specifically designed for demanding heavy-duty, marine, and transportation applications. They offer enhanced reliability, reduced size and weight, and improved efficiency compared to conventional products.

Applications include:

- Electric propulsion motors and generators in hybrid marine vessels, mobile work machines, and parallel hybrid buses
- Traction motors and generators in electric or hybrid-electric mobile work machines and buses

These electric machines use Synchronous Reluctance assisted Permanent Magnet (SRPM) motor technology, which offers several advanced features:

- Extremely compact and robust structure
- High efficiency across the entire operating range
- Liquid-cooling using a water-glycol mixture
- Minimum coolant flow required
- High coolant temperatures permissible
- IP65/IP67 rated enclosure for maximum reliability
- Multiple mounting possibilities
- Enhanced speed and torque capabilities compared to conventional PM machines
- High starting torques, delivering immediate torque to a stationary wheel
- Optimized speed range to accommodate the most common gear ratios used in heavy mobile machinery

EM-PMI375-T200

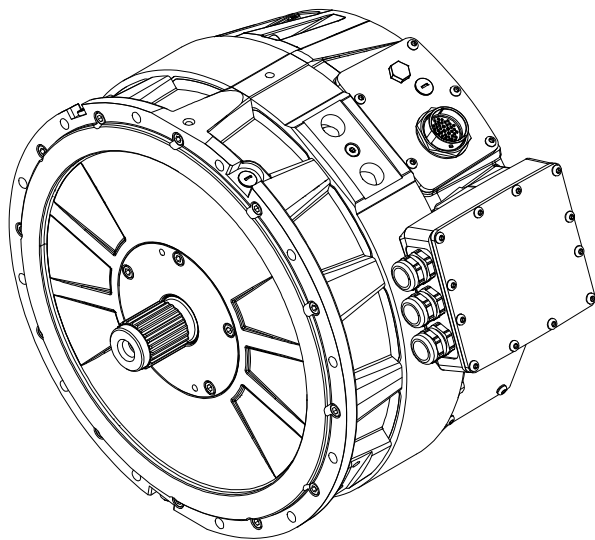

EM-PMI375-T500

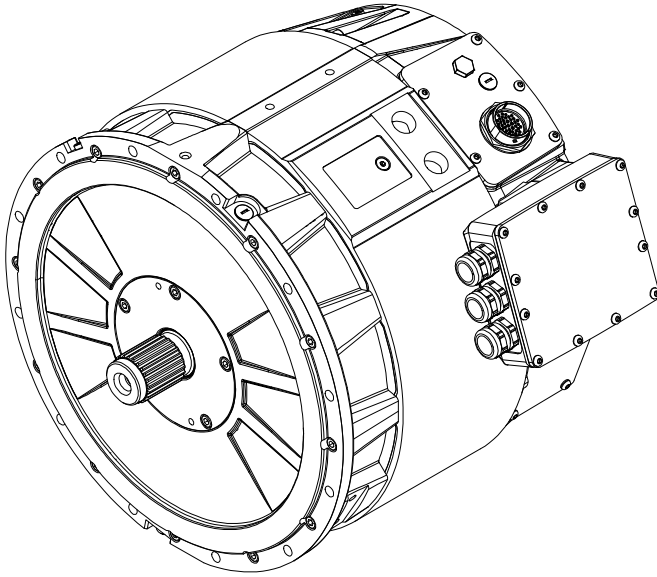

EM-PMI375-T800

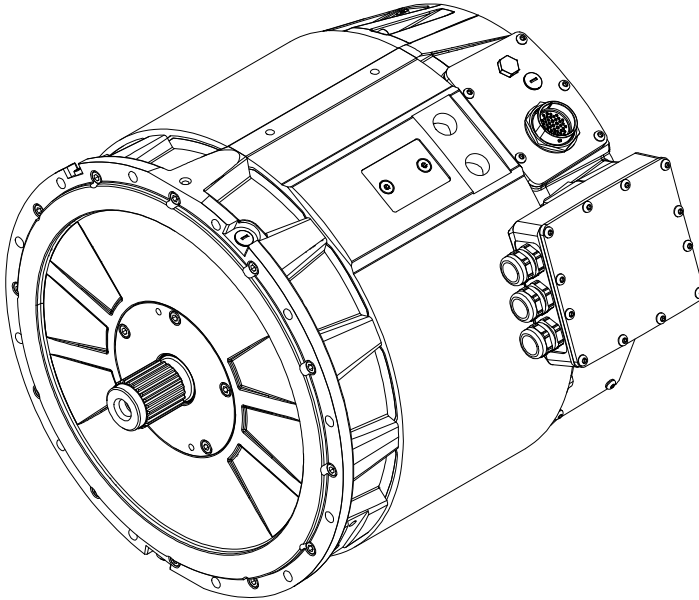

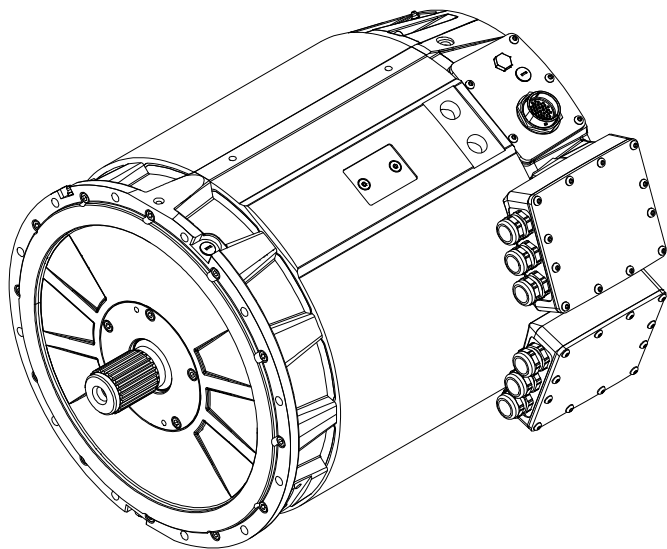
EM-PMI375-T1100

To provide optimal solutions for various applications, these electric machines are available in several frame models (sizes). They also offer options for shaft type, attachment interface, bearings, connection box attachment, rotation sensors, and temperature sensors.

Intended use of the electric machine

This electric machine is intended to operate as a motor or generator and is designed to be integrated into machinery, such as:

- Power train of a marine vessel, transportation vehicle or a heavy duty work machine
- Power generation equipment.

This electric machine requires an inverter or inverters to supply three-phase alternating current for power and control. It is not designed for direct online operation.

When used for power generation, these electric machines are intended to be driven by a prime mover, such as an internal combustion engine, and controlled by the inverter or inverters mentioned above.

This electric machine is exclusively for professional use and should only be operated and maintained by trained professionals.

Prohibited uses of the electric machine

The following uses, handling procedures, and maintenance practices are prohibited (this list is not exhaustive):

- Using the electric machine for purposes not specified in this user guide
- Failing to comply with this user guide, safety signs, and rating plate information of the electric machine
- Operating, adjusting, or performing maintenance on the electric machine before reading this user guide
- Operating the electric machine beyond its designed limits
- Using non-genuine service parts or parts with incorrect materials, potentially causing corrosion and eventual mechanical failures
- Operating and maintaining the electric machine without using the appropriate personal protective equipment
- Using electric machine parts, such as the frame, shaft end, or terminal box, for climbing or to support other structures
- Subjecting the electric machine to any kind of impact forces (for example, hitting, hammering, or dropping objects)
- Operating the electric machine using electrical connections not described in the user guide or other documentation
- Operating the electric machine when connections or cable glands are not properly tightened
- Operating the electric machine with power cables that are not routed according to the instructions
- Operating the electric machine without a cooling system that is correctly dimensioned and operating
- Operating the electric machine without following the bearing lubrication instructions
- Touching the electric machine's connection terminals or performing maintenance or adjustments while the power is connected

- Accessing the connection box(es) if the shaft can be turned by an external prime mover
- Lifting the electric machine from incorrect lifting points or without appropriate lifting equipment
- Lifting additional loads with the machine
- Storing the electric machine outdoors in wet or dusty environments
- Storing the electric machine without proper support to prevent it from rolling or falling
- Using the electric machine in potentially explosive environments
- Allowing dirt or liquid to enter the electric machine or connection box
- Using cables that cannot withstand the maximum currents of the electric machine

Used technology

As a Synchronous Reluctance assisted Permanent Magnet (SRPM) machine, this electric machine offers several benefits compared to standard permanent magnet (PM) and traditional induction machine (IM) technologies. SRPM technology combines the advantages of both PM and Synchronous Reluctance technology, resulting in increased torque capability over a wide speed range and the ability to produce torque at higher speeds. The machine also maintains good efficiency at lower speeds.

The supply current to the machine's stator windings generates a rotating magnetic field that rotates the rotor, which contains permanent magnets. In a synchronous permanent magnet machine, the rotor (shaft) rotation is synchronized with the frequency of the power supply current. The reluctance technology maximizes the machine's pull-out torque.

The rotor's permanent magnets feature a salient-pole design with embedded permanent magnets within the rotor structure. This design enhances the electric machine's mechanical stability and enables higher-speed operation. A simplified illustration of the magnet topology is shown below.

Machine topology

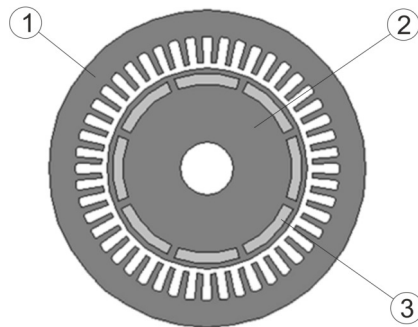

| | |
|---|---|
| 1 | Electric machine stator and stator windings |
| 2 | Electric machine rotor |
| 3 | Permanent magnets in the rotor |

System introduction

Danfoss delivers complete electric drivetrain solutions for heavy mobile machinery, marine vessels, and buses, enabling seamless transitions to hybrid electric (HEV) and fully electric (EV) vehicles. Our integrated systems reduce fuel consumption, emissions, and noise pollution.

Overview of the Danfoss drive train system

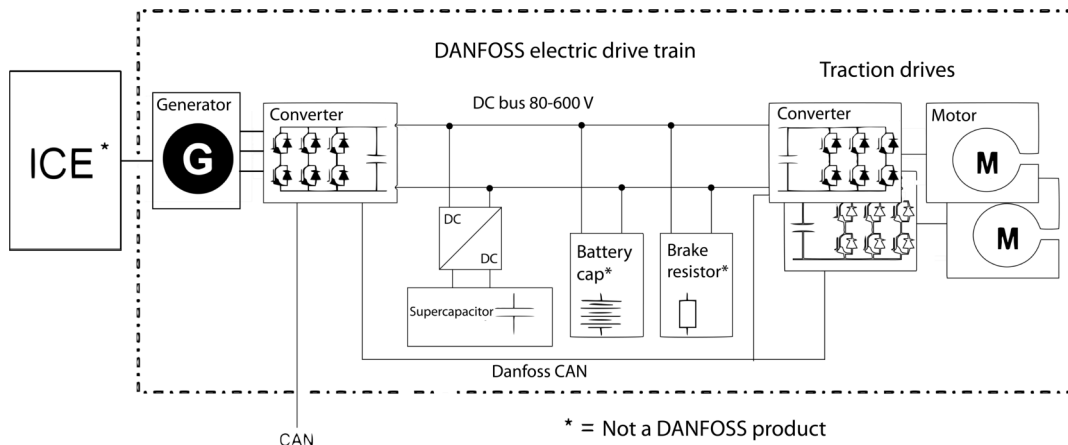

The electric machines are liquid cooled with water-glycol mixture. For more information, see [Cooling connections](#).

The electric machines incorporate a low-voltage connector for accessing various sensor signals. Depending on the machine configuration, this connector provides access to temperature and resolver data. For more information about the connection, see [Low voltage connections](#).

Depending on the model and specifications, some electric machines include one or two integrated anti-condensation heaters to prevent moisture buildup within the enclosure.

It is recommended to use a Danfoss inverter for optimized performance.

Connections and interfaces

Electric machines are mechanically and electrically integrated into machinery or power generation equipment.

Mechanical interfaces:

- Lifting points
- Flange mounting (D-end and N-end)
- Shaft connection(s)
- Cooling system connections (bores)
- Grease escape/fill connections; depending on model and option (+BHS): maintenance use only
- Air ventilation plug

Electrical interfaces:

- Power connections through the connection box
- Measurement connections
- Anti-condensation heater(s) connector (+HEAT1)
- Power grounding connection
- Low voltage (measurement signal) grounding connection

Connections and interfaces

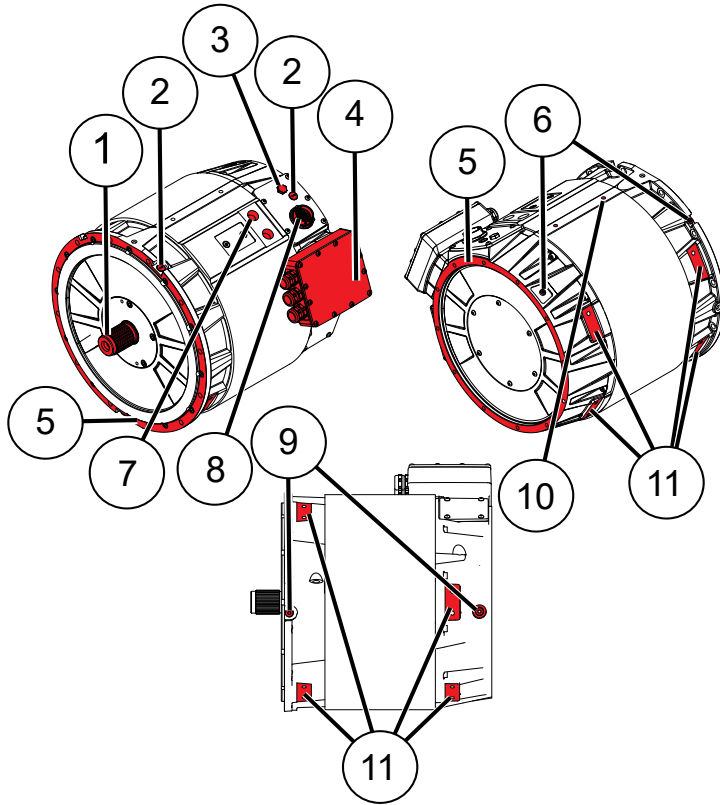



| | |
|----|--|
| 1 | Shaft connection |
| 2 | Bearing temperature sensors (Option +BTMP1) |
| 3 | Air ventilation plug |
| 4 | Connection box containing the power connections |
| 5 | Flange mountings, D-end and N-end |
| 6 | Grease fill connections (+BHS option dependent) |
| 7 | Cooling system connections (bores G3/4) |
| 8 | Low voltage connector (measurement connector), including low voltage grounding connector |
| 9 | Grease escape connection, D-end and N-end (+BHS option dependent) |
| 10 | Lifting points |
| 11 | Additional attachment points |

Rating plate

Each electric machine has a rating plate which can be found on the machine frame. The rating plate contains machine rating and identification. The rating values in the Figure below are not correct for this machine. See the rating plate on the machine and data sheets for the correct values.



Rating plate

| | | | |
|---|---------------|---|----------|
| ① EM-PMX-XXXX-XXXX | |  MADE IN FINLAND | |
| ② EM-PMX-XXXX-XXXX + XXXX + XXX + XXX | | | |
| Serial No. XXXXX - XXXXXXXXX | | | |
| U: XXX V | Qc: XX l/min | IP rating: | IPXX |
| I: XX A | Pole pairs: X | Cooling: | XXX |
| P: XX kW | Tc: XX °C | Rotation: | XXX |
| n: XXXX rpm | Mounting: XX | Max n: | XXXX rpm |
| T: XXX Nm | Mass: XXX kg | Insul. class: | XXX °C |
| PF: XXX | Duty: XX | Temp. class: | XXX °C |
| f: XXX Hz | Tamb: XX °C | Bear./ D-end: | XXX |
| | | Bear./ N-end: | XXX |
| | | Max. Pressure: | X bar |
|  | | Manuf.: 20XX | |
| | | Danfoss A/S, 6430 Nordborg, Denmark | |

Rating plate fields

| Field | Explanation | Unit |
|------------------|---|------------------|
| 1 | Electric machine product family: EM-PMI or EM-PME | |
| 2 | Electric machine type code and options | |
| Serial No. | Serial number | |
| U | Rated voltage (phase-to-phase AC) | V _{rms} |
| I | Rated current (AC) | I _{rms} |
| P | Rated power (S9) according to IEC60034-1 | kW |
| n | Rated speed | rpm |
| T | Rated torque (S9) at rated speed | Nm |
| PF | Power factor | |
| f | Rated supply frequency at nominal speed | Hz |
| Q _c | Rated coolant liquid flow | l/min |
| Pole pairs | Number of magnetic pole pairs of the machine | |
| T _c | Rated coolant liquid input temperature | °C |
| Mounting | Allowed mounting position according to IEC60034-7 | |
| Mass | Mass of the electric machine | kg |
| Duty | Defined rotating electric machine duty cycles by IEC60034-1 standard | |
| T _{amb} | Rated ambient temperature | °C |
| IP rating | Enclosure class according to IEC60034-5 | |
| Cooling | Cooling method according to IEC60034-6 | |
| Rotation | Direction of rotor rotation with default phase order. Observed facing the D-end. | |
| Max n | Maximum rotation speed | rpm |
| Insul. class | Temperature rating (class) of insulation of the electric machine according to IEC60034-1 | |
| Temp. class | Temperature rating (class) of individual insulation materials of the insulation according to IEC60034-1 | |
| Bear. / D-end | Bearing type (types) in the D-end of the electric machine | |
| Bear. / N-end | Bearing type in the N-end of the electric machine | |
| Max. pressure | Cooling liquid max pressure | |
| CE | Declaration of conformity with the requirements of EU legislation | |

Tightening torques

| | |
|---|--|
|  | Unless otherwise specified, the acceptable tightening torque range is within +/- 5 % of the stated value. |
|  | Use threadlocking adhesive for RST, that is, stainless steel bolts to avoid breakage. |

Do not install dry screws or other fastening equipment. Always add suitable lubrication, for example Wurth HSP 1400, to prevent excess friction.

| Connection | Tightening torque |
|---|-------------------|
| Mounting bolts for D-end attachment | 40 Nm |
| Mounting bolts for N-end attachment (support or auxiliary components) | 30 Nm |
| Connection box mounting screws | 7 Nm |
| Connection box cover plate screws | 4 Nm |
| Cable lug | 15 Nm |

Tightening torques to use unless otherwise noted





| | 8.8 | 10.9 | 12.9 |
|--------|-----|------|------|
| Thread | Nm | Nm | Nm |
| M5 | 7 | 10 | 11 |
| M6 | 11 | 17 | 19 |
| M8 | 27 | 40 | 47 |
| M10 | 54 | 79 | 93 |
| M12 | 93 | 137 | 160 |
| M14 | 148 | 218 | 255 |
| M16 | 230 | 338 | 395 |

Design principles

This Chapter describes design principles that must be taken into account when designing the system using the electric machine.

System design

Cooling and temperature measurement

| | |
|---|---|
|  | Do not operate the electric machine without correctly dimensioned and operating cooling system. |
|  | Mount the electric machine in correct position, see Chapter <i>Allowed mounting position</i>. |
|  | When you connect the cooling system make sure that the cooling medium flows freely in and out from the electric machine with the cooling medium flow equal or higher than rated. |
|  | The cooling medium temperature at the inlet of the electric machine must be lower or equal to the rated temperature. |

The electric machines are liquid-cooled using max. 50 % water-glycol coolant. The used cooling method is IC 9S7Y7 (IEC 60034-6 classification), requiring an external heat exchanger. See also Chapter *Recommended coolants*.

See more detailed information about coolant connection bore specifications, required coolant liquid flow and other specifications in the product data sheet. Rated values can be found from the electric machine rating plate.

The electric machine has at least one PT100 temperature sensor in the windings. The amount of the sensors depend on the options chosen. The temperature signal(s) can be read out from the measurement connector of the machine.

You can connect one temperature signal to the temperature surveillance pin in the inverter (EC-C1200) and make sure that the inverter has the machine temperature protection feature activated.

The maximum allowed winding temperature of the electric machine is shown in the rating plate and in the data sheet.

The PT100 temperature sensor characteristics are: resistance 100 Ω at 0°C temperature, and the resistance increases 0.385 Ω per each 1°C increase of temperature.

Insulation lifetime

| | |
|---|---|
|  | Factors like thermal cycling, environmental conditions, moisture, and vibration impact the electric machine's insulation lifespan. This lifespan is a calculated prediction and is not tested in practice. |
|---|---|

The insulation lifetime expectancy of the electric machine is shown in the following table.

| Insulation class | Continuous measured stator temperature | Lifetime expectancy |
|------------------|--|---------------------|
| H 180°C | 150°C | 100 000 h |
| H 180°C | 175°C | 20 000 h |

Inverter

The electric machine is intended to be powered and controlled with an inverter capable of supplying three-phase alternating current and that is capable of controlling the electric machine. The electric machine is not suitable for direct online use.

If the electric machine is driven with an inverter from a supplier other than Danfoss Editron, the electric machine performance may differ from rated values. The optimum performance of the electric machine is obtained with Danfoss Editron inverters. These inverters are:

- Compact and light.
- Liquid cooled.
- Tolerant to high mechanical vibration (10 G) and shock (50 G).
- Efficient, efficiency > 98 %.
- Reliable, no moving components.



Do not exceed the maximum rotation speed of the electric machine.

EC-C1200



Schematic of the inverter powerstage

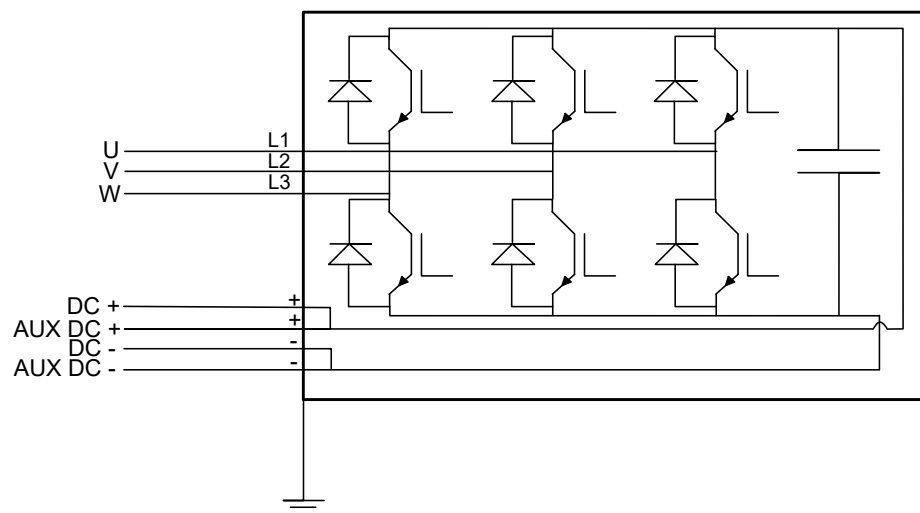

The main machine power driving parameters are shown in the machine rating plate. For more information, contact Danfoss representative.

You can connect one of the temperature signals (from the low voltage connector) to the temperature surveillance pin in the inverter and make sure that the inverter has the machine temperature protection feature activated.

Mounting structure

Supporting structure requirements



Do not install the electric machine near or in direct contact with easily flammable materials. The surface of the electric machine can be hot.

The mating housing arrangement of the electric machine must be secure and sufficiently rigid to prevent vibrations and mechanical failures. Necessary actions should be taken to avoid corrosion on the mating housing arrangement.

The supporting structure for the electric machine must be such that the electric machine can be mounted using its allowed mounting positions, see Chapter *Allowed mounting positions*.

The mounting space must be adequate for the electric machine mounting and possible auxiliary components. See the length and the diameter data of the electric machine from the product drawing. Main dimensions of the electric machine are shown in the Figure below (the illustration may differ from the actual electric machine).

The electric machine has a SAE 3 D-end flange (IM 3001). A SAE 3 flywheel housing is required as mating flange. The machine's N-end flange (SAE 4 flywheel housing) can be used for auxiliary components or support. Do not use the N-end for mounting the electric machine.

Main dimensions of the electric machine

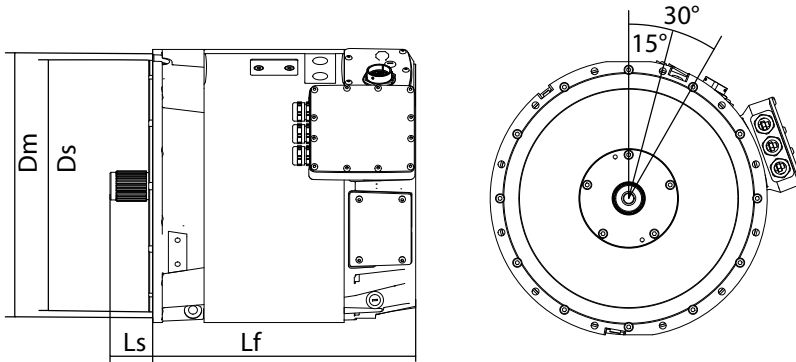

| Symbol | Explanation |
|--------|--|
| L_F | Length of the electric machine frame (including the connection box(es)). |
| L_S | Length of the shaft (from the end of the shaft to the electric machine D-end mounting shoulder). |
| D_M | Diameter of the flange mounting bore circle. |
| D_S | Diameter of the mounting shoulder. |

For all dimensions of the electric machine, see the product drawings.

Shaft alignment and load



Proper alignment is crucial to prevent bearing overloads, premature bearing failures, excessive vibration, and shaft failures. Use of flexible coupling is recommended. However, it does not compensate for excessive misalignment, so always perform a proper alignment procedure regardless of the coupling type used.

The type of the electric machine shaft is W50x2x24x8f for EM-PMI375-T200/T500/T800 and W55x2x26x8a for EM-PMI375-T1100. Recommended female connection counterpart is of type N50x2x24x9H. The flange type is SAE3.

Alignment between the shaft and mating structure must be accurate. Proper alignment is crucial to prevent bearing overloads, premature bearing failures, excessive vibration and shaft failures. Flexible coupling does not compensate for excessive misalignment, so always perform a proper alignment procedure regardless of the coupling type used.

The misalignment can be parallel or angular misalignment, or combination of those. With parallel misalignment, the center lines of both shafts are parallel but they are offset. With angular misalignment, the shafts are at an angle to each other. Figures below illustrate the parallel and angular misalignment.

Parallel alignment of the shaft and mating structure

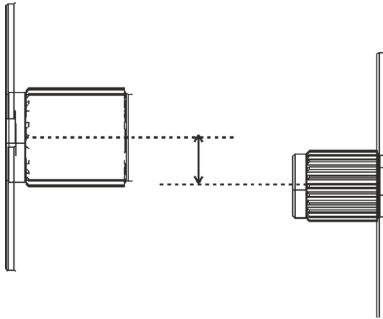

Maximum parallel misalignment values

| | Non-flexible coupling * | Flexible coupling * |
|-----------|-------------------------|---------------------|
| rpm | mm | mm |
| 0-1000 | 0.07 | 0.13 |
| 1000-2000 | 0.05 | 0.10 |
| 2000-3000 | 0.03 | 0.07 |
| 3000-4000 | 0.02 | 0.05 |
| 4000-6000 | < 0.02 | 0.03 |

* The values given might differ between coupling types.

Angular alignment of the shaft and mating structure

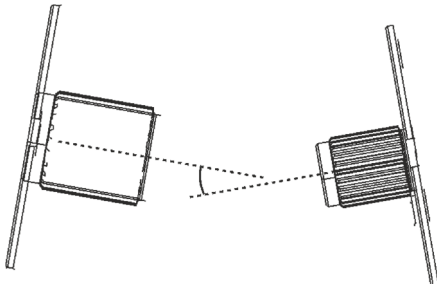

Maximum angular misalignment values

| | Non-flexible coupling * | Flexible coupling * |
|-----------|-------------------------|---------------------|
| rpm | mm / 100 mm | mm / 100 mm |
| 0-1000 | 0.06 | 0.10 |
| 1000-2000 | 0.05 | 0.08 |
| 2000-3000 | 0.04 | 0.07 |
| 3000-4000 | 0.03 | 0.06 |
| 4000-6000 | < 0.03 | 0.05 |

* The values given might differ between coupling types.



The maximum external force directed to the shaft axially and radially may not exceed machine specific values. For more information, see document DOC-000454. Calculate the relevant values with the help of the document. Contact Danfoss service at <https://danfossedatron.zendesk.com/hc/en-gb> or send email to editron.service@danfoss.com to obtain the document.

External shaft forces of the electric machine

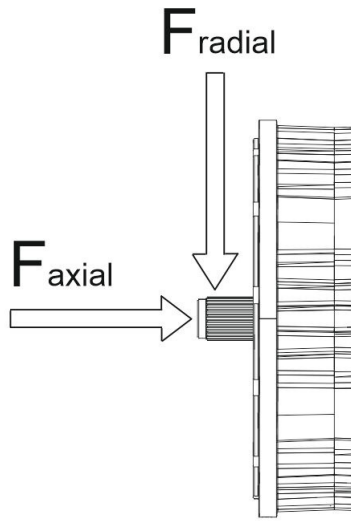

Transportation and storage



Transportation

| | |
|---|---|
|  | Heavy equipment. Handle with care during transportation. |
|---|---|

Electric machine is shipped in first class condition. It has been inspected and packed correctly to prevent damage from ordinary handling during shipment. During transportation, shocks, falls and humidity should be avoided. Protect the cooling holes for transportation.

The weight of the electric machine can be found on the machine rating plate, and in the product data sheet.





Receiving and unpacking





| | |
|--|--|
|  | Do not touch the electric machine during the insulation resistance check. Discharge the electric machine afterwards. |
|  | Do not touch the electrical terminals when the rotor is rotated. The electrical terminals have dangerous voltage during rotation. Contact Danfoss representative if the rotor can not be rotated. |
|  | Remove the transportation supports of the electric machine. |

Check upon arrival and unpacking

- The electric machine and the package must be inspected immediately upon arrival. Make sure that the rating plate data in the cover letter complies with the purchase order. Any external damage (in shaft-ends, flanges, electrical interfaces and paint) must be photographed and reported immediately.
- It is recommended to measure the insulation resistance of the electric machine upon arrival, or before installing the electric machine. Reference value of 500 MΩ shall be exceeded in room temperature, otherwise contact Danfoss representative. Refer to Chapter *Insulation resistance test* on page 30.
- Remove any transportation supports and shaft locks and rotate the shaft. It is normal for the rotation of the shaft to be difficult.

Lifting

| | |
|---|---|
|  | Use correct, adequately dimensioned lifting devices and inspect them before lifting. |
|  | Do not lift from the shaft of the electric machine! |
|  | Do not apply any excess weight on the electric machine when lifting. |
|  | Use correct lifting slings. Use correct position and angle of lifting. |

| | |
|---|---|
|  | See the electric machine rating plate for weight information. |
|  | Lift the electric machine using the correct lifting lugs/eyes only. |
|  | Do not go under a lifted load. |
|  | Lifting slings cannot touch the electric machine during the lifting. |

Lifting lugs/eyes/points for lifting slings and lifting position of the electric machine

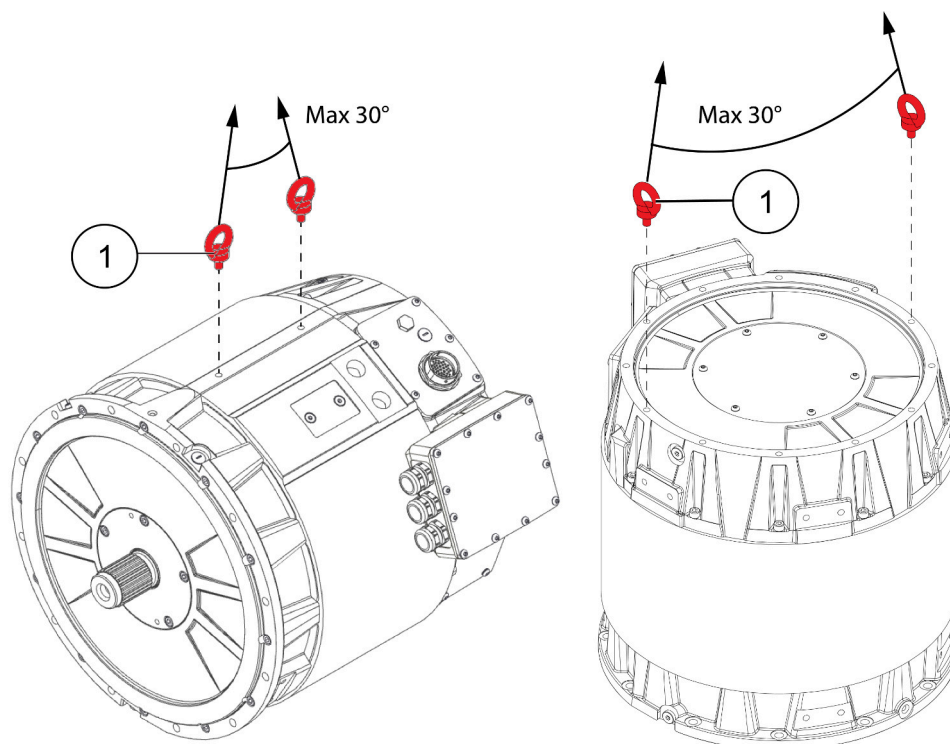

1 Lifting eye type of ANSI B18.15.1M M10x16 is recommended in M10 bores. Not included in the delivery.

Horizontal lifting

Install 2 pieces of lifting eyes to the lifting bores of the electric machine frame. Mount the lifting eyes with their full threaded length.

Vertical lifting

Install 2 pieces of lifting eyes to the lifting bores in the N-end SAE flange. Lifting eye should be mounted with its full threaded length.

Storage

| | |
|---|--|
|  | Do not touch the electrical terminals when the shaft is rotated. The electrical terminals have dangerous voltage during rotation. |
|---|--|



Keep the electric machine on a correct base. Support the electric machine to prevent accidental turning and falling.

- Always store the electric machine indoors. Storage temperature must be above -20°C and relative humidity less than 60 %.
- The storage should be dry, dust free and vibration free.
- Treat the unprotected electric machine surfaces such as the shaft-end and flanges against corrosion. Seal the cable exit holes and cooling bores for storage.
- The electric machine must not be subject to any external vibrations during storage to avoid damage to the bearings.
- To avoid water condensing in the electric machine, use anti-condensation heater(s), if fitted, or direct winding heating to keep the machine temperature above dew point.
- Rotate the shaft of the electric machine by hand monthly at least ten revolutions to prevent grease migration. If necessary use a tool such as a spanner. Do not damage the shaft in any case.

Extended storage

Electric machines equipped with relubricable bearings: apply grease before and after long term storage.





It is recommended to inspect the electric machine in storage at periodic intervals. Use attached storage checklist.

Rotate the shaft of the electric machine once a month.

Keep the electric machine in its installation position while in storage. For example, vertically installed electric machines should be stored in vertical position.

Installation

The following safety and information related symbols appear in this user guide and on the electric machine.



| | |
|--|--|
|  | Risk of electric shock when the connection box is open. When you work with power connections make sure that electricity is disconnected and rotor rotation is prevented. Use isolated electric tools. Always ensure there is no voltage present at the power connections before working on the device by measuring the connections with a multimeter or voltage tester. |
|  | Magnetic and electromagnetic fields generated near the current-carrying conductors and permanent magnets in electric machines represent a health danger to persons with heart pacemakers, metal implants and hearing aids. Persons with a heart pacemaker, metal implants or hearing aids must consult a doctor before they enter the following areas: <ul style="list-style-type: none"> • Areas in which electric equipment and parts are operated. • Areas in which electric equipment with permanent magnets are stored, mounted, operated or repaired. |
|  | Only trained and qualified personnel familiar with the relevant safety requirements can work with the electric machine. |
|  | Use correct personal protective equipment when you are near the electric machine. |
|  | Read the instructions in this user guide before you install the electric machine. |

Required tools

Following tools are required to install the electric machine:

- Grease pump.
- Ratchet torque wrench.
- Hex head wrench kit with different metric sizes.
- Socket wrench kit with different metric sizes.
- Cable gland tightening tool. Size according to cable glands.
- Cable skinning knife.
- Crimping tool for cable lugs. Consult cable lug manufacturer for correct size and crimping.
- Lifting slings with sufficient rated capacity.
- Lifting eyes. Size according to machine type. See Chapter *Lifting* on page 27.

Insulation resistance test

| | |
|---|--|
|  | Before performing the insulation resistance measurement, disconnect all cables and connectors from the electric machine under test. |
|  | Do not touch the electric machine during the insulation resistance check. Discharge the electric machine afterwards. |
|  | Measure the insulation resistance of the electric machine before and after the installation of the electric machine. |

Measure the insulation resistance of the electric machine before and after the installation of the electric machine. Because of the structure of the electric machine, it is possible that the stator is damaged during the installation.

Reference value of 500 M Ω has to be exceeded at reference ambient temperature 25°C (measured with 500 V_{DC} / 1 min insulation resistance test). Contact Danfoss Editron service if the reference value is not exceeded.

Measuring the insulation resistance



Insulation resistance testers generate lethal voltages. Only qualified personnel should perform insulation resistance measurements.

The insulation resistance is measured between motor terminals and the frame. When measuring the windings, the auxiliary circuits and other windings are grounded. When measuring the auxiliary circuits, all windings are grounded.

Single winding motors

The following table lists test conditions and pass criteria for the electric machines.

| Test voltage | Test duration | Pass criteria |
|---------------------|---------------|------------------|
| 500 V _{DC} | 60 s | > 500 M Ω |

Measurement procedure:

1. Connect all pins of the LV connector, bearing temperature sensors and heaters to the motor frame.
2. Connect the measurement device's ground cable to the motor frame.
3. Connect the measurement probe to the winding phases.

Single winding motors

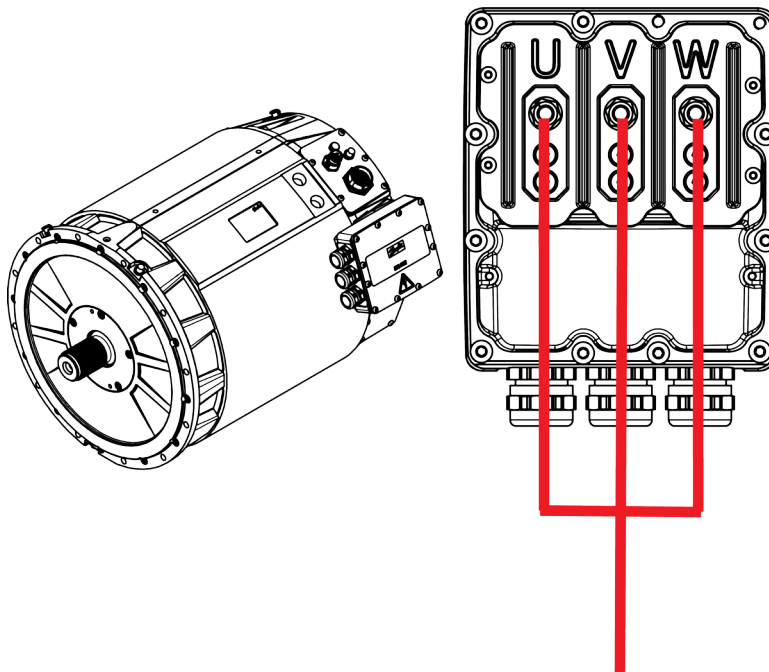

Dual winding motors - Winding 1

| Test voltage | Test duration | Pass criteria |
|---------------------|---------------|------------------|
| 500 V _{DC} | 60 s | > 500 M Ω |

Measurement procedure:

1. Connect winding 2 phases to the motor frame.
2. Connect all pins of the LV connector, bearing temperature sensors and heaters to the motor frame.
3. Connect the measurement device's ground cable to the motor frame.
4. Connect the measurement probe to the winding 1 phases.

Dual winding motors - winding 1

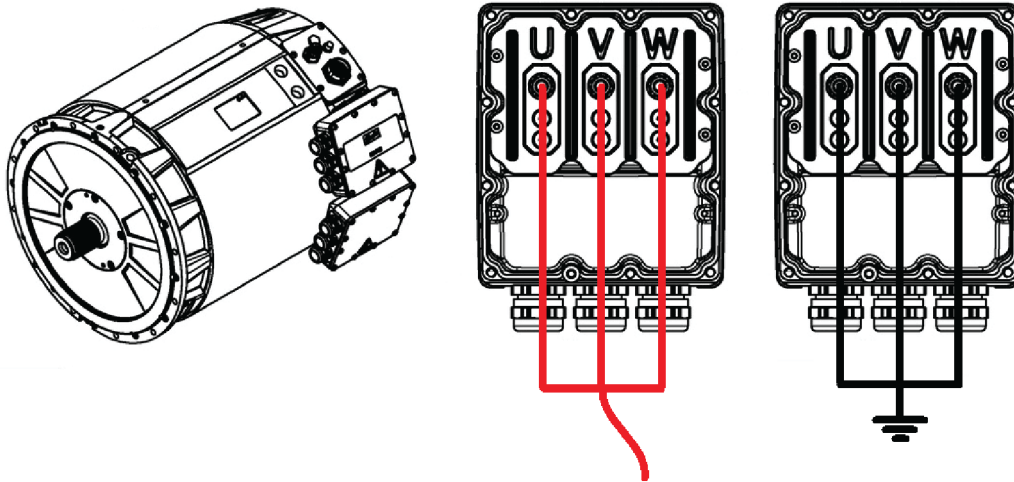

Dual winding motors - Winding 2

| Test voltage | Test duration | Pass criteria |
|---------------------|---------------|---------------|
| 500 V _{DC} | 60 s | > 500 MΩ |

Measurement procedure:

1. Connect winding 1 phases to the motor frame.
2. Connect all pins of the LV connector, bearing temperature sensors and heaters to the motor frame.
3. Connect the measurement devices ground cable to the motor frame.
4. Connect the measurement probe to the winding 2 phases.

Dual winding motors - winding 2

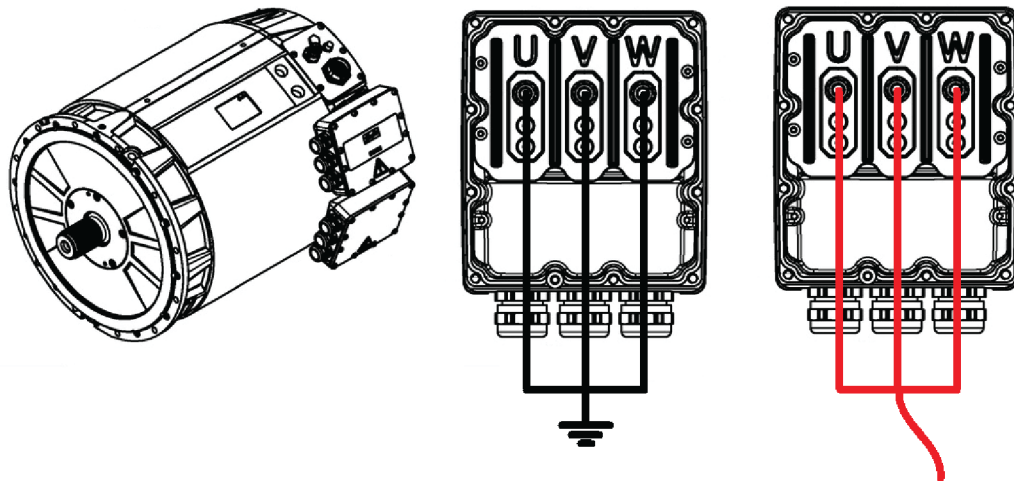



Mechanical installation

Allowed mounting positions

| | |
|---|--|
|  | <p>It is in some cases possible to make an exception from the limitations of the mounting positions. Document <i>Allowed bearing loads for EM-PMI machines DOC-000454</i> gives more information about this. Contact Danfoss to obtain the document.</p> |
|---|--|

If the application is a moving work machine or similar, it is allowed to deviate from the allowed mounting position for the duration of 30 % of the work cycle. This applies to electric machines with grease lubricated bearings.

See Figure(s) below for mounting limitations of the electric machine.

| Line type | Meaning |
|---|---|
|  | Allowed machine tilt angle for continuous operation. (viewed from the shaft end) |
|  | Allowed momentary machine tilt angle, for the maximum duration of 30 % of the work cycle. (viewed from the shaft end) |

Allowed machine tilt angle during operation

EM-PMI375-T200, -T500, -T800 +BHS

EM-PMI375-T200, -T500, T800

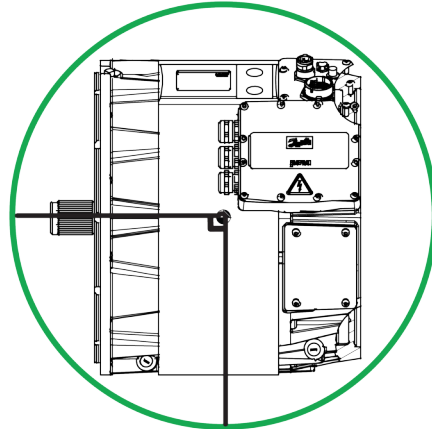
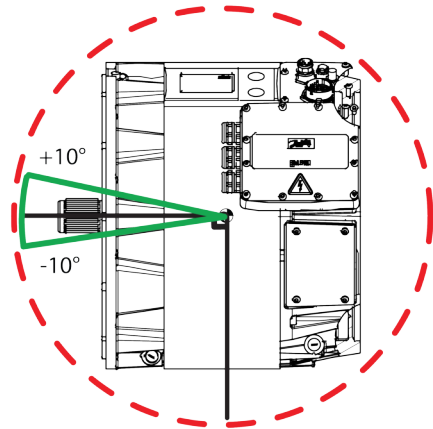

EM-PMI375-T1100

EM-PMI375-T1100 +BGL

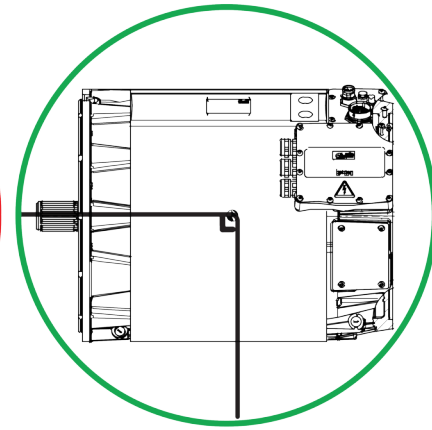
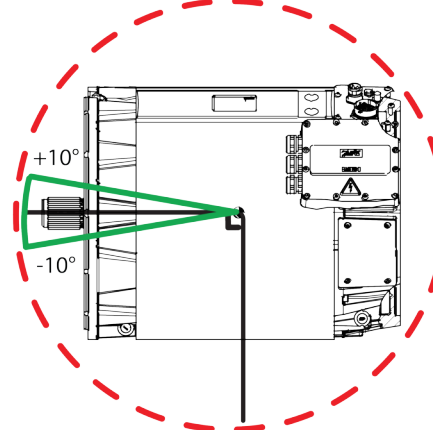



Allowed horizontal mounting positions, front view

EM-PMI375-T200, -T500, -T800 +BHS
EM-PMI375 -T1100

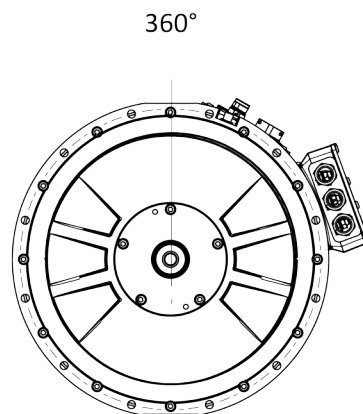
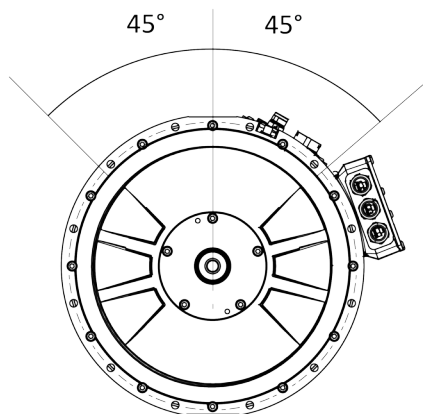
EM-PMI375-T200, -T500, -T800
EM-PMI375-T1100 +BGL



Mounting the electric machine

| | |
|---|---|
|  | Do not exceed the maximum axial and radial forces calculated for the shaft. Document Allowed bearing loads for EM-PMI machines DOC-000454 gives more information about this. Contact Danfoss to obtain the document. |
|  | Do not use the N-end of the electric machine for mounting the electric machine. |
|  | Refer to Chapter <i>Allowed mounting positions</i> for the correct mounting positions of the electric machine. |

Mount the electric machine on a correct supporting structure as discussed in Chapter *Supporting structure requirements*.

Horizontal assembly

1. Lift the electric machine to the correct mounting position. See Chapter *Lifting* for details.
2. The electric machine is mounted from its D-end flange (SAE3 transmission housing flange). SAE3 flywheel housing is required as a mating flange.
3. Align the electric machine with the mating housing alignment. See Chapter *Shaft alignment and load*.
4. Connect electric machine shaft, ensuring full spline engagement. Lubricate the spline. *Before* connecting the shaft, ensure the splines are clean and free of protective wax to prevent lubricant contamination.

The recommended spline lubricant is a 50/50 mixture of high-temperature grease and molybdenum disulfide powder. Apply initially and reapply regularly to prevent fretting corrosion and premature wear. This lubricant is oil-insoluble. Suitable alternatives include Molycote, Metaflux, Never-Seez, and Optimol.

5. Attach the D-end mounting bolts. For steel housing, the minimum length of the bolt is 35 mm and for aluminum housing 40 mm. (40 mm and 45 mm for EM-PMI375-T800). Use tightening torque of 40 Nm. See also *Tightening torques* on page 21.

6. The electric machine N-end flange (SAE 4 flywheel housing) can be used for auxiliary components or support. Do not use the N-end for mounting the electric machine. Use tightening torque of 30 Nm for N-end bolts.

Mechanical mounting connections of the electric machine (horizontal mounting)

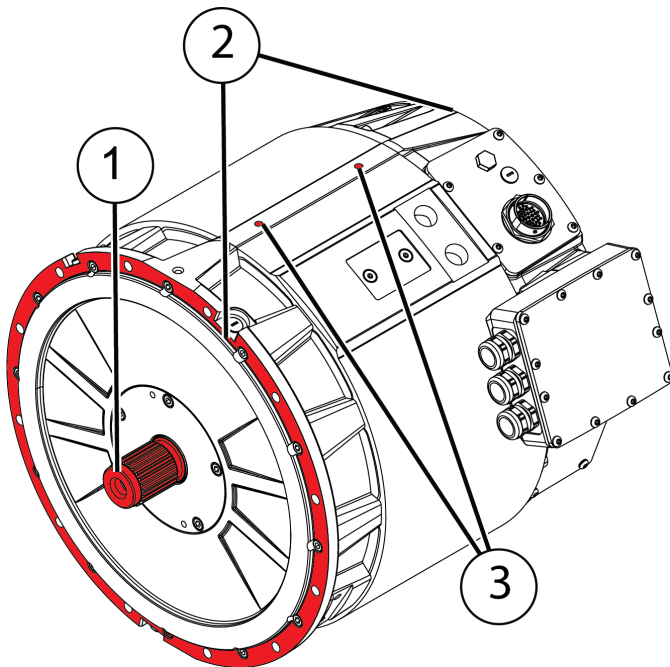

| | |
|---|--|
| 1 | Shaft of the electric machine; spline structure of the shaft DIN 5480 W50x2x24x8f (EM-PMI375-T200/T500/T800) or W55x2x26x8a (EM-PMI375-T1100). |
| 2 | D-end flange (SAE3) and bolt bores for mounting the electric machine. |

| | |
|---|---|
| | N-end flange (SAE 4 flywheel housing) with 12x30°xM10x1.5 bores. Depth of the thread is 19 mm. Minimum bolt thread engagement of 15 mm is required. |
| 3 | Bores for the lifting eyes. |
| | Mounting bolts (12 pcs of DIN 912 M10). Not included in the delivery. |
| | Shaft (male) in the N-end of the electric machine with +NE2 option is DIN 5480 W50x2x24x8f (EM-PMI375-T200/T500/T800) or W55x2x26x8a (EM-PMI375-T1100). |

Vertical assembly

In vertical assembly, follow the Steps given in the previous Section *Horizontal assembly*.

Mechanical mounting connections of the electric machine (vertical mounting)

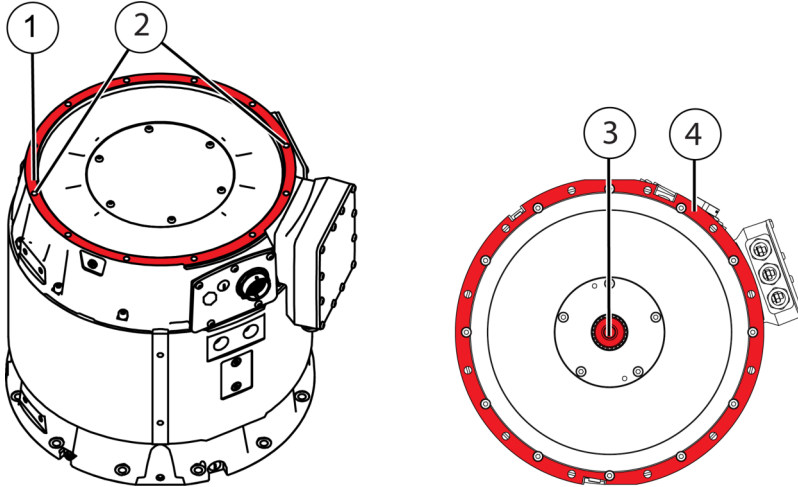

| | |
|---|---|
| 1 | N-end flange (SAE 4 flywheel housing) with 12x30°xM10x1.5 bores. Depth of the thread is 19 mm. Minimum bolt thread engagement of 16 mm is required. |
| 2 | Bores for the lifting eyes, N-end. |
| 3 | Shaft of the electric machine; spline structure of the shaft (DIN5480 W50x2x24x8f for EM-PMI375-T200/T500/T800 or W55x2x26x8a for EM-PMI375-T1100). |
| 4 | D-end flange (SAE3). Use mounting bolts (12 pcs of DIN 912 M10, not included in the delivery). |

Side mounting holes, +SM1 option

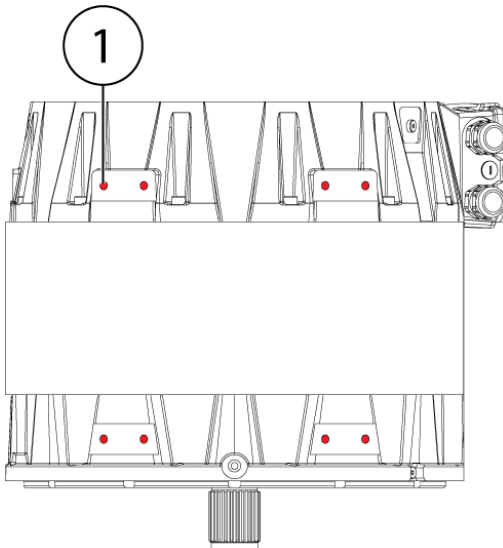

| | |
|---|--|
| 1 | Side mounting threaded holes M10x1.5, 12 pcs |
|---|--|

All side mounting threaded holes (12 pcs) are plugged by default with M10x10, DIN 913, (ISO 4026), set screw.

Use a normal hexagonal socket screwdriver to open the plugs you need to remove. Note that only plugs in holes which are going to be used should be removed.

Cooling connections

Connect the electric machine properly to the cooling circuit. Make sure that the coolant flow is equal or higher than rated and the coolant temperature at the inlet of the machine cooling is lower or equal to the rated temperature. For more information, see Chapter *Recommended coolants* and product data sheet. Rated values can be found in the electric machine rating plate.

Make sure that cooling liquid runs freely into and out from the electric machine.

Cooling connectors have G3/4 bores.

When selecting cooling liquid nipples, choose nipples that can resist galvanic corrosion.

To prevent damage to the cooling connectors, refer to the documentation of the manufacturer for the correct tightening torque of the cooling liquid nipples.

Aluminum frame water-cooled construction is only to be used with a closed fresh water circulation with corrosive inhibitor described in the data sheet. The water cooling circuit connection is described in the data sheet. Use only suitable and high-class connection parts and seals to connect the electric machine to the water circuit. Check for possible leaks after the piping and joints have been connected.

It is recommended to use coolant connector equipped with o-ring seal or to use sealing washer (for example Usit or Bonded seals) in the connection. In addition, it is recommended to use thread sealant (Loctite 577 or similar) at the coolant connections to prevent loosening. Loosening can be caused by vibration or temperature variations.



The electric machines are equipped with at least three PT100 temperature sensors in the windings. The amount of the sensors depend on the options chosen. The temperature signal(s) can be read out from the measurement connector of the machine.

You can connect the temperature signal to the temperature monitoring pin in the inverter (EC-C) and make sure that the inverter has the electric machine temperature protection feature activated.

Electrical installation

Power connections

High voltage connection

| | |
|---|---|
|  | Risk of electric shock when connection box is open. When you work with power connections make sure that electricity is disconnected and shaft rotation is prevented. Always ensure there is no voltage present at the power connections before working on the device by measuring the connections with a multimeter or voltage tester. |
|  | Make sure the power cables exit straight from the terminals and do not rub against the sharp cable through-holes or other sharp edges which could wear out the cable insulation over time. |
|  | Do not place any excess weight on the connection box lid(s). |

The high voltage cables of the electric machine are connected to the connection box(es) of the electric machine. The figure below shows the components of the high voltage connection box assembly.

You are allowed to open only the nuts and bolts that are specified here. Only Danfoss professionals are allowed to open other nuts and bolts in the terminal box.

Customer cables and cable lugs are shown in the figure below.

Installing the power cables:

1. Remove the cover of the terminal box.
2. Install the power cables.

- a. Remove the cable lug attachment nut/bolt and washers.
 - b. Place the cable lug against the busbar.
 - c. Place flat washer on top of the cable lug and spring washer on top of the flat washer.
 - d. Screw on the nut/bolt and tighten. Refer to Section *Tightening torques* on page 21 for the correct torque.
3. Install the cover of the terminal box back.

When installing the connection box lid, ensure that the mating surfaces are clean and free of any foreign particles. Verify that all connection box fasteners are present and properly tightened. Missing or loose fasteners can compromise the insulation and create a safety hazard.

For more information on how to install the power cables, see especially steps 8-13 in *Cable gland assembly and power line connection* on page 38.

High voltage connection assembly structure

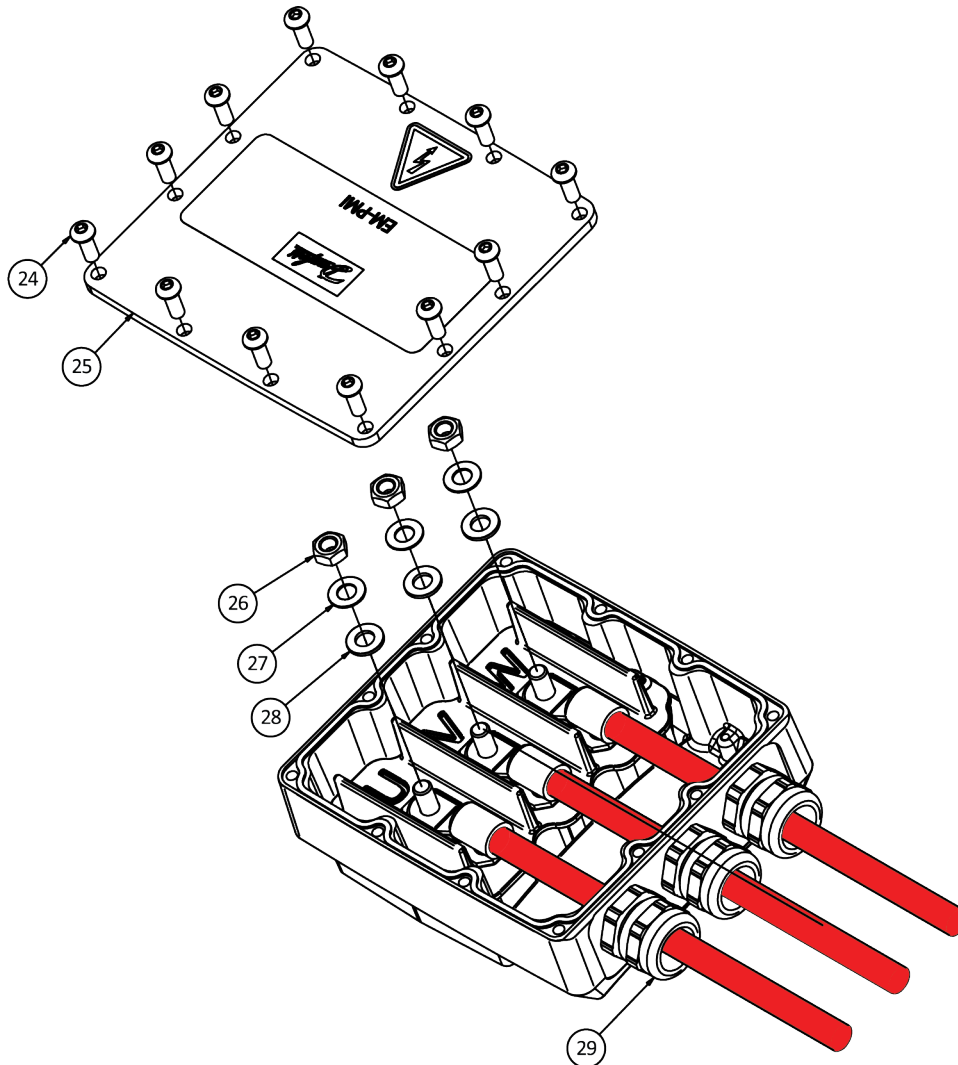

All connection box modules have the same phase order as shown in the following figure.

| Part number | Qty | Description | Type |
|-------------|-----|-------------------|---------------------------------|
| 24 | 12 | Bolt, socket head | M6 x 16, ISO 7380, A4-70 |
| 25 | 1 | Plate, T=5 | Gasket extruding |
| 26 | 3 | Nut | M8, DIN 934, zinked |
| 27 | 3 | Spring, Disc- | D8, DIN 2093, 8.2 x 16 x 0,9 |
| 28 | 3 | Washer | D8, DIN 125 |
| 29 | 3 | Cable gland | M25 x 1.5, BG 225MSTRI Pflitsch |

Connection diagram

The electric machines are intended to be powered and controlled by three-phase alternating current, supplied by an inverter or inverters. The electric machine is not suitable for direct online use.

The amount of inverters depends on the electric machine and converter current ratings. See also the relevant wiring diagrams.

For an electric machine with option SINGLE (one connection box containing one three-phase system), the electrical connection principle from the inverter is shown in the figure below.

Connection diagram for SINGLE option

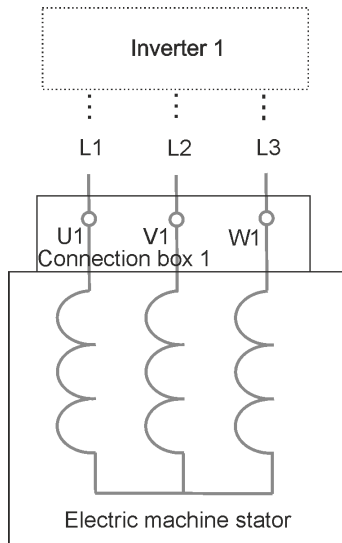

For an electric machine with option DUAL (two connection boxes each containing one three-phase system), the electrical connection principles from the inverters are shown in the figure below.

Connection diagram for DUAL option

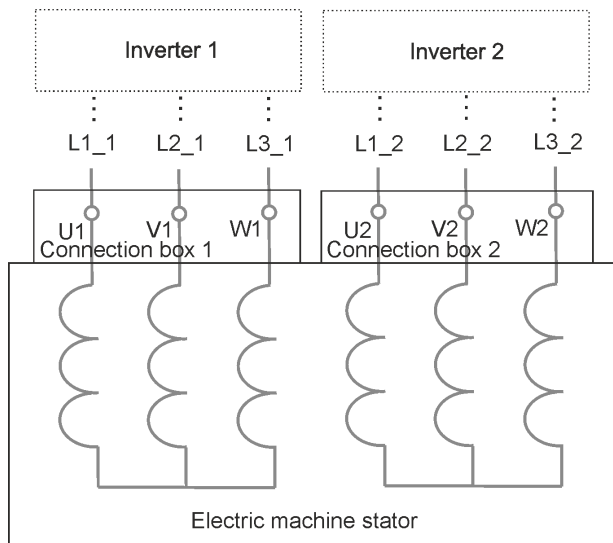

For single-inverter operation of a DUAL electric machine, the phase cables must be connected in parallel as shown in the figure below. Incorrect phase sequencing during parallel connection will result in improper operation and risk of machine damage.

Cable gland assembly and power line connection



If you are not using the recommended cable lugs, select cable lugs that leave 10 mm gap between each and every cable lug on the same connection plate.

This Chapter describes how to assemble screened power cables to the electric machine. See the cable glands recommendations from the Table below. Cable gland assembly instruction can also be found from PFLITSCH gland catalog available from <http://www.pflitsch.de>.

Use correct type of gland for different cable diameters. These are shown in the Table below.

Cable gland alternatives

| Cable gland | Cable cross sectional area (*) | Thread | Max. cable Ø | Max. shield Ø |
|-----------------------|--|-------------------|--------------|---------------|
| Pflitsch bg 225ms tri | 35 mm ² 50 mm ² 70 mm ² | M25 x 1.5, 7.5 mm | 20 mm | 16 mm |

(* Applicable with the recommended cable type (HUBER+SUHNER Radox Elastomer S)

BlueGlobe cable gland tightening torques

| Metric thread | Nominal torque |
|---------------|----------------|
| M10 x 1.0 | 3.0 Nm |
| M12 x 1.5 | 5.0 Nm |
| M16 x 1.5 | 8.0 Nm |
| M20 x 1.5 | 10.0 Nm |
| M25 x 1.5 | 15.0 Nm |
| M32 x 1.5 | 15.0 Nm |
| M40 x 1.5 | 20.0 Nm |
| M50 x 1.5 | 30.0 Nm |
| M63 x 1.5 | 35.0 Nm |
| M75 x 1.5 | 80.0 Nm |
| M85 x 2.0 | 100.0 Nm |

The pictures are schematic, and the actual components can look different.

1. Remove the small hexagonal piece from the BlueGlobe-sealing insert as shown in Figure below.

BlueGlobe-sealing

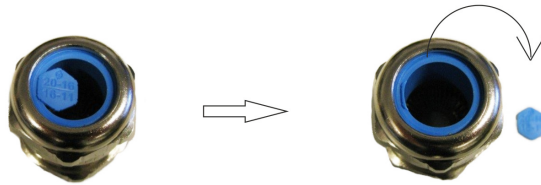

2. Cut the cable sheath at the distance A from the end of the cable, see Figure below. Pull the cut part of the sheath partly (length B is from 10 to 15 mm) off the cable as shown in the Figure. The distance A depends of the length of the cable lug used. Measure with the cable lug that is used and cut to suitable length.



Do not remove the cable sheath completely at this point and do not cut the braid screen of the cable!

Cut length of the cable sheath

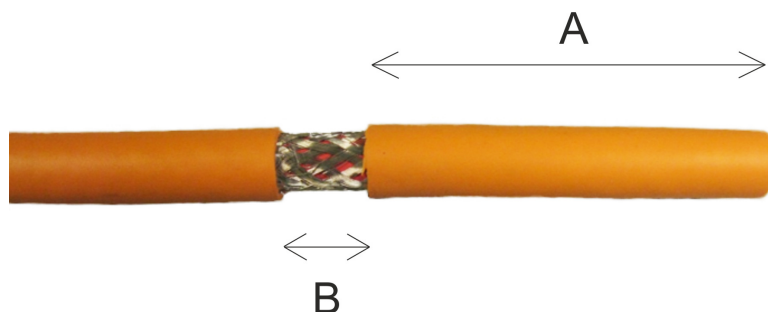

- 3.** Wrap two layers of copper tape on the cable so that the distance B is covered. Use 3M™ Copper Foil Tape 1181 or similar. Contrary to the image below and depending on the cable and the cable gland size, you can leave the length A sheath in place for the next step to help the placement of the cable gland and remove the sheath only after the next step.

Cover the cable with copper tape

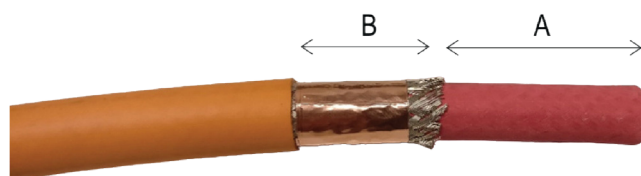

- 4.** Insert the cable to the cable gland with slight turning motion. This helps the cable to go through the spring inside the cable gland. Push the cable gland against the sheath of the cable as shown in Figure below.

Cable to the gland assembly



- 5.** After the cable gland is in place remove the length A piece of the sheath and cut the braid screen (cover) from 10 mm (distance C) from the gland bottom as shown in Figure below. *Before cutting the braid screen, verify that the cable gland spring is correctly positioned against the cable sheath, which must be protected with copper tape.*

Cut the braid screen

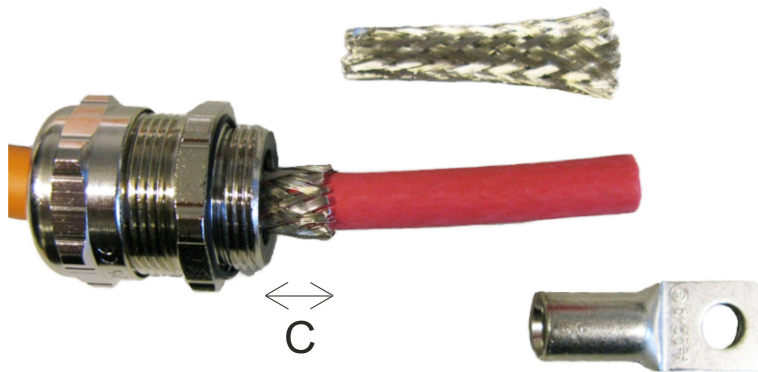

6. Cut a piece of length D of the inner sheath shown below in the Figure *Cutting the inner sheath*. The length D must equal to the length of the cable lug body.

Cutting the inner sheath

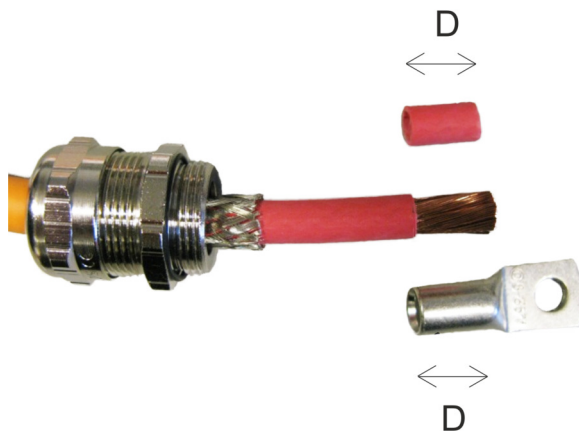

7. a) Make sure that the conducting strands of the cable are completely free of silicone and other impurities. Insert cable conductors fully into cable lug. Make sure that the cable lug is not too loose and that all conductors fit inside the lug. If not, check from the part list that you are using the correct cable lugs.
- b) Always use the crimping tool of the cable lug manufacturer. Before crimping, check the cable lug size from the lug (e.g. 35-8 is 35 mm²) and select the same size dies for the crimping tool. Use hexagonal dies.
- c) Crimp the cable lug at least twice in different places starting as near to the flat part of the lug as possible and towards the barrel part of the lug. Make sure that the cable does not slip out from the lug while crimping.
- d) Remove any excess compound emerging from the sides of the cable lugs after the crimping. Verify that the cable lug is evenly compressed with clear hexagonal crimps and that no conductors are broken. See Figure below.

Connecting cable lug



8. Cut piece of shrink tube and shrink it over the cable lug and braid screen as shown in Figure below. This is done to keep the braid screen in place and for extra insulation. Use shrink tube rated for -40°C to 150°C . Self-gluing type is recommended.

Shrink tube



9. Insert the cable through the corresponding hole in the connection box and connect the cable lug to the connection point. Use spring washer between the cable lug and the connection screw or nut. Do not tighten the connection at this point to ensure fitting of the cable gland.

Ensure a minimum 10 mm air gap between the cable lug and other metallic structures including the braid of the cable. If the air gap is smaller, use extra insulation shrink tube to cover the lug.

Cable lug connection to the connection box (example only, the connection box may look different)

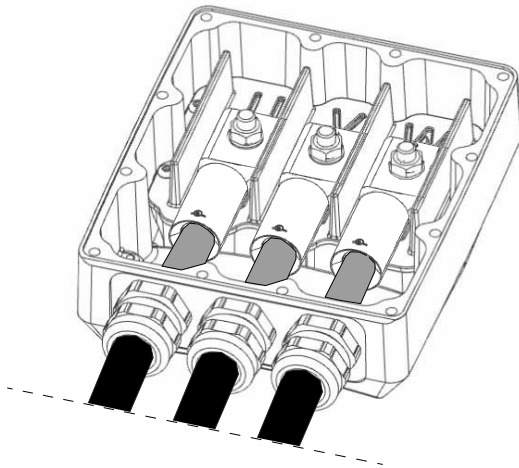

10. Screw the cable gland to the connection box as shown in the Figure above.



Tighten the cable gland from the cable gland body to enclosure. Refer to *Tightening torques* on page 21 for the correct torque. Then tighten the cap of the cable gland according to the instructions provided by cable gland manufacturer (recommendation Pflitsch).

11. Tighten the cable lug. Use tightening torque of 15 Nm.

12. Repeat the procedure to the other cables and connection box if needed.

13. Check that the phase connections order in the connection box is correct, that is, the corresponding phases between the inverter and the machine are connected (U, V, W correspond to the L1, L2, L3 phases).

14. Close the connection box. Tighten the connection box cover screws. See Chapter *Tightening torques*. Use thread locking compound that makes it possible to remove the screws. (For example Loctite 221).

15. Check the power cable shield grounding, see Chapter *Grounding connections*.

Cable lug and cable gland assembly cross section

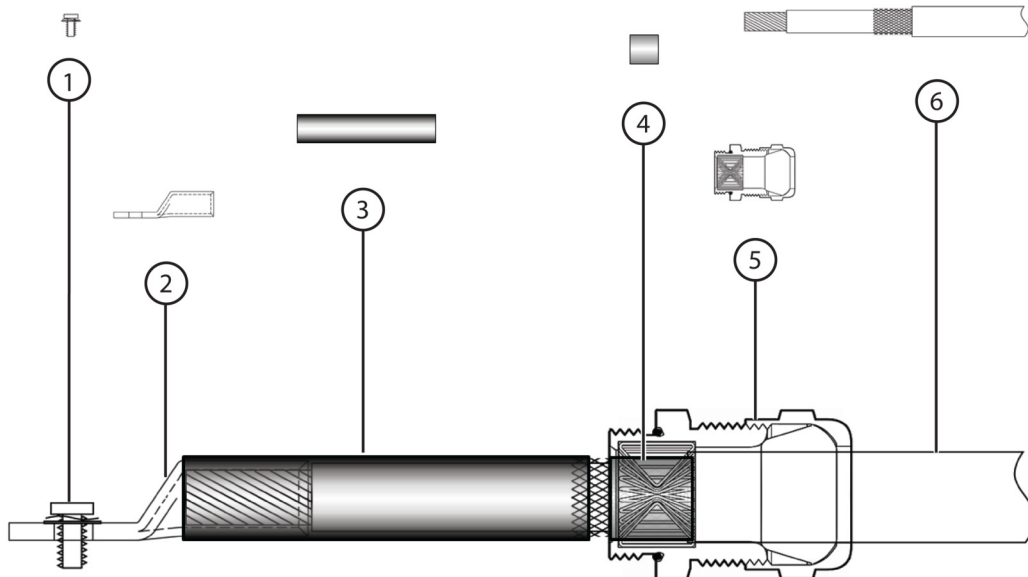

| | |
|---|--|
| 1 | Cable lug bolt or nut with washers (depending on the electric machine) |
| 2 | Cable lug |
| 3 | Shrink wrap |
| 4 | Copper tape |
| 5 | Cable gland |
| 6 | Cable |

Low voltage connections



The electric machine uses a low voltage connector or, optionally, a low voltage connection box (+LVB1).

The electric machine has a connector or a connection box which is used to read out inbuilt temperature and rotation sensor (resolver) data from the electric machine. The temperature data comes from PT100 sensors in the stator windings and in some cases in the bearings. The rating plate has the information about the options of the electric machine: different options add sensors, and some electric machines do not have all the sensors. For more information about the options, refer to Chapter *Product naming convention* on page 5.

IP67 level protection is reached only when connector mating part is installed and all unused pin holes are plugged in the connector mating part with the following plugs, depending on the hole size:

- DEUTSCH 0413-003-1605 (size 16)
- DEUTSCH 0413-204-2005 (size 20)

For more information and instructions contact the connector manufacturer directly at <https://www.deutschconnector.com/>.

Recommended cable types for low voltage connections

| Application | Cable type |
|---------------------------------|-------------------------------|
| Resolver cabling | Shielded cable (twisted pair) |
| Temperature measurement (PT100) | Shielded cable (twisted pair) |

Low voltage connector (1), Deutsch HD34-24-47PE

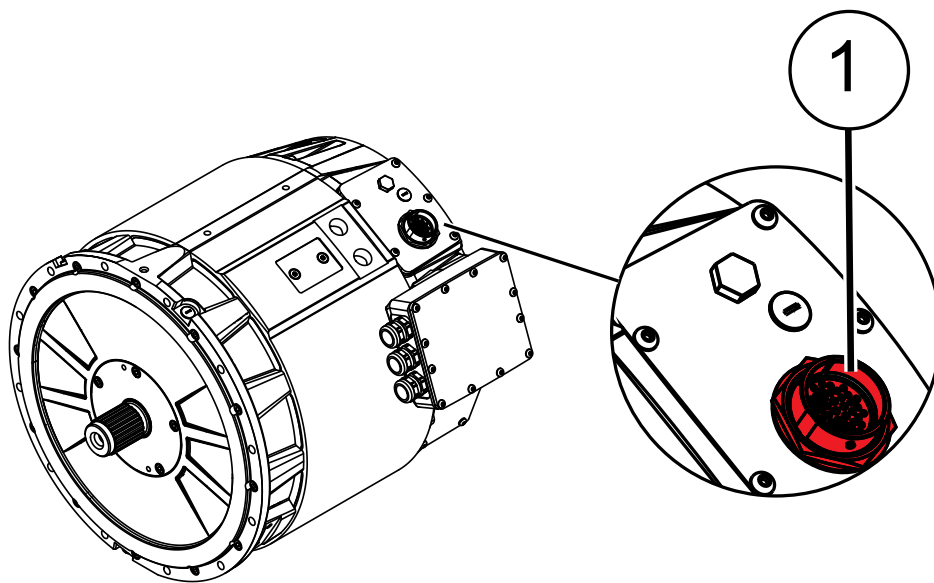

Low voltage connector details



Deutsch HD34-24-47PE connector has two kinds of mating pins: 1 mm and 1.5 mm in diameter.

Pin configuration of the Deutsch HD34-24-47PE connector

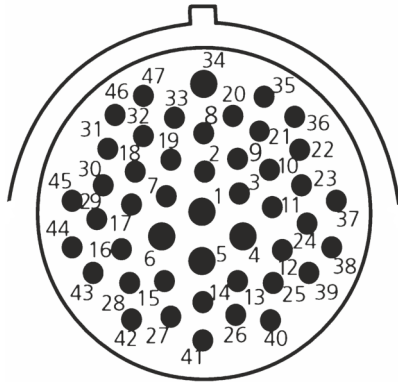

Pin configuration of the Deutsch HD34-24-47PE connector (EM-PMI375-T200)

| PIN | Description | Option |
|-----|---|--------|
| 47 | Temperature 1, PT100 (P), windings | |
| 46 | Temperature 1, PT100 (N), windings | |
| 33 | Temperature 2, PT100 (P), windings | |
| 32 | Temperature 2, PT100 (N), windings | |
| 45 | Temperature 3, PT100 (P), windings | |
| 31 | Temperature 3, PT100 (N), windings | |
| 30 | Temperature 4, PT100 (P), windings | +TEMP4 |
| 29 | Temperature 4, PT100 (N), windings | +TEMP4 |
| 44 | Temperature 5, PT100 (P), windings | +TEMP4 |
| 43 | Temperature 5, PT100 (N), windings | +TEMP4 |
| 28 | Temperature 6, PT100 (P), windings | +TEMP4 |
| 16 | Temperature 6, PT100 (N), windings | +TEMP4 |
| 35 | Resolver, RES_COS_N, inbuilt non-contacting | +RES1 |
| 20 | Resolver, RES_COS_P, inbuilt non-contacting | +RES1 |
| 36 | Resolver, RES_SIN_N, inbuilt non-contacting | +RES1 |
| 21 | Resolver, RES_SIN_P, inbuilt non-contacting | +RES1 |
| 22 | Resolver, EXCN, inbuilt non-contacting | +RES1 |
| 10 | Resolver, EXCP, inbuilt non-contacting | +RES1 |
| 34 | Resolver, SHIELD/GROUND, inbuilt non-contacting | +RES1 |

Pin configuration of the Deutsch HD34-24-47PE connector (EM-PMI375-T500/T800/T1100)

| PIN | Description | Option |
|-----|------------------------------------|--------|
| 47 | Temperature 1, PT100 (P), windings | |
| 46 | Temperature 1, PT100 (N), windings | |
| 33 | Temperature 2, PT100 (P), windings | |
| 32 | Temperature 2, PT100 (N), windings | |
| 45 | Temperature 3, PT100 (P), windings | |
| 31 | Temperature 3, PT100 (N), windings | |
| 30 | Temperature 4, PT100 (P), windings | +TEMP4 |
| 29 | Temperature 4, PT100 (N), windings | +TEMP4 |
| 44 | Temperature 5, PT100 (P), windings | +TEMP4 |
| 43 | Temperature 5, PT100 (N), windings | +TEMP4 |
| 28 | Temperature 6, PT100 (P), windings | +TEMP4 |
| 16 | Temperature 6, PT100 (N), windings | +TEMP4 |
| 42 | Temperature 7, PT100 (P), windings | +TEMP5 |

Pin configuration of the Deutsch HD34-24-47PE connector (EM-PMI375-T500/T800/T1100) (continued)

| PIN | Description | Option |
|-----|---|--------|
| 27 | Temperature 7, PT100 (N), windings | +TEMP5 |
| 15 | Temperature 8, PT100, (P) windings | +TEMP5 |
| 14 | Temperature 8, PT100 (N), windings | +TEMP5 |
| 40 | Temperature 9, PT100 (P), windings | +TEMP5 |
| 26 | Temperature 9, PT100 (N), windings | +TEMP5 |
| 41 | Temperature 10, PT100 (P), windings | +TEMP5 |
| 13 | Temperature 10, PT100 (N), windings | +TEMP5 |
| 39 | Temperature 11, PT100 (P), windings | +TEMP5 |
| 38 | Temperature 11, PT100 (N), windings | +TEMP5 |
| 25 | Temperature 12, PT100 (P), windings | +TEMP5 |
| 12 | Temperature 12, PT100 (N), windings | +TEMP5 |
| 35 | Resolver, RES_COS_N, inbuilt non-contacting | +RES1 |
| 20 | Resolver, RES_COS_P, inbuilt non-contacting | +RES1 |
| 36 | Resolver, RES_SIN_N, inbuilt non-contacting | +RES1 |
| 21 | Resolver, RES_SIN_P, inbuilt non-contacting | +RES1 |
| 22 | Resolver, EXCN, inbuilt non-contacting | +RES1 |
| 10 | Resolver, EXCP, inbuilt non-contacting | +RES1 |
| 34 | Resolver, SHIELD/GROUND, inbuilt non-contacting | +RES1 |

Bearing temperature measurement connector (optional), both ends of electric machine

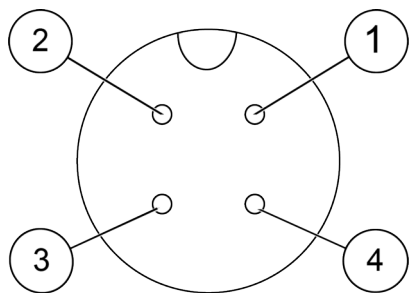

| | |
|---|------------------|
| 1 | PT100 pin |
| 2 | PT100 pin |
| 3 | PT100 ground pin |
| 4 | PT100 ground pin |

Low voltage connection box details

Low voltage connection box (+LVB1)

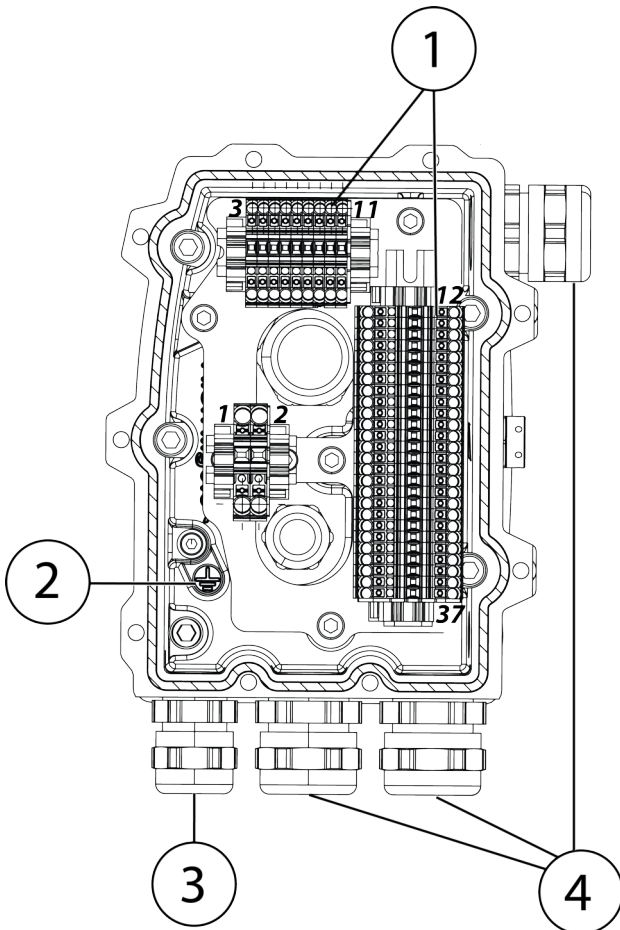
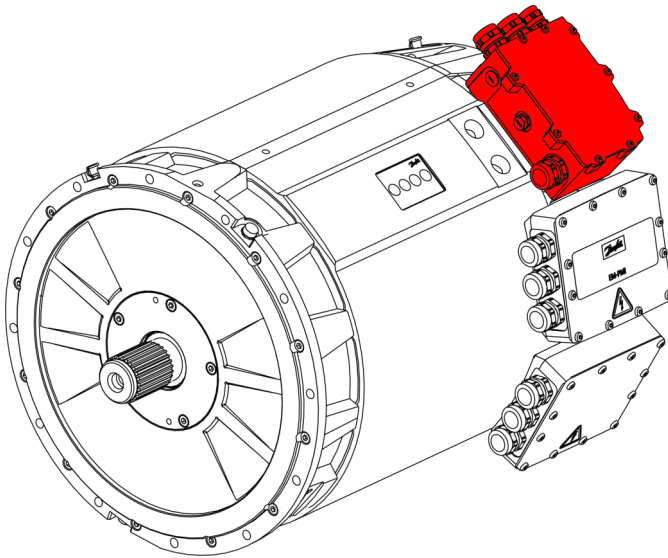

| | |
|---|---------------------------|
| 1 | Terminal blocks |
| 2 | Grounding connection (M4) |
| 3 | 1 x M20 cable gland |
| 4 | 3 x M25 cable glands |

Pin configuration of +LVB1 connection (EM-PMI375-T200)

| Rails | PIN | Description | Option | |
|----------|---------|--|-----------------------------------|--------|
| Rail 1 | 1 | Heater, phase, 230 V _{AC} | +HEAT1 | |
| | 2 | Heater, neutral | +HEAT1 | |
| M4 screw | ∅ | General shielding, ground / protective earth | | |
| Rail 2 | 3 | Resolver | RES_COS_N, Inbuilt non-contacting | +RES1 |
| | 4 | Resolver | RES_COS_P, Inbuilt non-contacting | +RES1 |
| | 5 | Resolver | RES_SIN_N, Inbuilt non-contacting | +RES1 |
| | 6 | Resolver | RES_SIN_P, Inbuilt non-contacting | +RES1 |
| | 7 | Resolver | EXCN, Inbuilt non-contacting | +RES1 |
| | 8 | Resolver | EXCP, Inbuilt non-contacting | +RES1 |
| | 9 | Not in use | | |
| | 10 | Temperature | PT100 (P), bearing, N-end | +BTMP1 |
| | 11 | Temperature | PT100 (N), bearing, N-end | +BTMP1 |
| Rail 3 | 12 | Temperature 1 | PT100 (P), windings | |
| | 13 | Temperature 1 | PT100 (N), windings | |
| | 14 | Temperature 2 | PT100 (P), windings | |
| | 15 | Temperature 2 | PT100 (N), windings | |
| | 16 | Temperature 3 | PT100 (P), windings | |
| | 17 | Temperature 3 | PT100 (N), windings | |
| | 18 | Temperature 4 | PT100 (P), windings | +TEMP4 |
| | 19 | Temperature 4 | PT100 (N), windings | +TEMP4 |
| | 20 | Temperature 5 | PT100 (P), windings | +TEMP4 |
| | 21 | Temperature 5 | PT100 (N), windings | +TEMP4 |
| | 22 | Temperature 6 | PT100 (P), windings | +TEMP4 |
| | 23 | Temperature 6 | PT100 (N), windings | +TEMP4 |
| | 24 | Reserve | | |
| | 25 | Reserve | | |
| | 26 | Reserve | | |
| | 27 | Reserve | | |
| | 28 | Reserve | | |
| 29 | Reserve | | | |
| 30 | Reserve | | | |
| 31 | Reserve | | | |
| 32 | Reserve | | | |
| 33 | Reserve | | | |
| 34 | Reserve | | | |
| 35 | Reserve | | | |
| 36 | Reserve | | | |
| 37 | Reserve | | | |

Pin configuration of +LVB1 connection (EM-PMI375-T500/T800/T1100)

| Rails | PIN | Description | Option |
|--------|-----|------------------------------------|--------|
| Rail 1 | 1 | Heater, phase, 230 V _{AC} | +HEAT1 |
| | 2 | Heater, neutral | +HEAT1 |





Pin configuration of +LVB1 connection (EM-PMI375-T500/T800/T1100) (continued)

| Rails | PIN | Description | Option | |
|----------|--------|--|---|---------------------|
| M4 screw | ☒ | General shielding, ground / protective earth | | |
| Rail 2 | 3 | Resolver | RES_COS_N, Inbuilt non-contacting +RES1 | |
| | 4 | Resolver | RES_COS_P, Inbuilt non-contacting +RES1 | |
| | 5 | Resolver | RES_SIN_N, Inbuilt non-contacting +RES1 | |
| | 6 | Resolver | RES_SIN_P, Inbuilt non-contacting +RES1 | |
| | 7 | Resolver | EXCN, Inbuilt non-contacting +RES1 | |
| | 8 | Resolver | EXCP, Inbuilt non-contacting +RES1 | |
| | 9 | Not in use | | |
| | 10 | Temperature | PT100 (P), bearing, N-end | +BTMP1 |
| | 11 | Temperature | PT100 (N), bearing, N-end | +BTMP1 |
| | Rail 3 | 12 | Temperature 1 | PT100 (P), windings |
| 13 | | Temperature 1 | PT100 (N), windings | |
| 14 | | Temperature 2 | PT100 (P), windings | |
| 15 | | Temperature 2 | PT100 (N), windings | |
| 16 | | Temperature 3 | PT100 (P), windings | |
| 17 | | Temperature 3 | PT100 (N), windings | |
| 18 | | Temperature 4 | PT100 (P), windings | +TEMP4 |
| 19 | | Temperature 4 | PT100 (N), windings | +TEMP4 |
| 20 | | Temperature 5 | PT100 (P), windings | +TEMP4 |
| 21 | | Temperature 5 | PT100 (N), windings | +TEMP4 |
| 22 | | Temperature 6 | PT100 (P), windings | +TEMP4 |
| 23 | | Temperature 6 | PT100 (N), windings | +TEMP4 |
| 24 | | Temperature 7 | PT100 (P), windings | +TEMP5 |
| 25 | | Temperature 7 | PT100 (N), windings | +TEMP5 |
| 26 | | Temperature 8 | PT100 (P), windings | +TEMP5 |
| 27 | | Temperature 8 | PT100 (N), windings | +TEMP5 |
| 28 | | Temperature 9 | PT100 (P), windings | +TEMP5 |
| 29 | | Temperature 9 | PT100 (N), windings | +TEMP5 |
| 30 | | Temperature 10 | PT100 (P), windings | +TEMP5 |
| 31 | | Temperature 10 | PT100 (N), windings | +TEMP5 |
| 32 | | Temperature 11 | PT100 (P), windings | +TEMP5 |
| 33 | | Temperature 11 | PT100 (N), windings | +TEMP5 |
| 34 | | Temperature 12 | PT100 (P), windings | +TEMP5 |
| 35 | | Temperature 12 | PT100 (N), windings | +TEMP5 |
| | | 36 | Reserve | |
| | | 37 | Reserve | |

Grounding connections



Ground the electric machine from its frame to make sure it functions correctly and safely.

| | |
|---|---|
|  | Ground the cable shields of the power cables to make sure the electric machine functions correctly and safely. |
|  | Ground the cable shields of the instrumentation cables to make sure the electric machine functions correctly and safely. |
|  | The cross sectional area of the protective earth conductor must be at least equal to that of the incoming supply conductor. |
|  | It is recommended to perform a ground bond test after installing the electric machine to make sure the electric machine is correctly grounded. |
|  | The grounding points on the frame of the electric machine are for safety grounding, and signal cables and power cable shields have their own grounding points. |

The machine enclosure grounding point, safety grounding

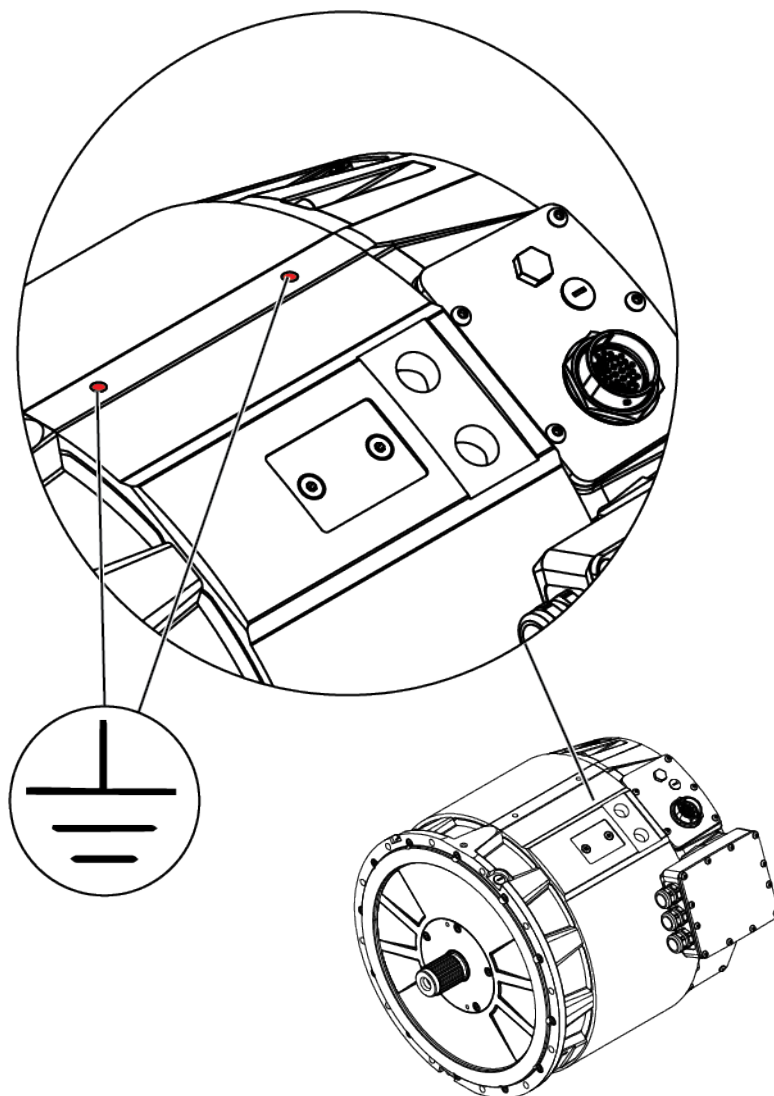

Testing the power cable shield grounding (earthing)

The power cable shields are grounded (earthed) through the cable glands to the connection box and further to the electric machine enclosure. After the cable gland assembly and power cable installations, and any time when needed, make sure that the grounding (earthing) connections are correct.

1. Connect one terminal of the measurement device to the cable shield of one power cable (in the inverter end of the cable)
2. Connect the other terminal of the measurement device to the cable shield of an other power cable. You can also use the machine enclosure grounding point for the measurement.
3. Measure the resistance between the two cable shields or between the cable shield and the enclosure grounding point.
4. Change the measurement device terminal(s) to the shield of different power cable and repeat the measurement until all cables have been measured.

Testing the low voltage (measurement signal) cable shield grounding (earthing)

The low voltage (measurement signal) cable shield is connected to the grounding (earthing) point. After cable installation, and any time when needed, make sure that the grounding (earthing) connection is valid.

1. Connect one terminal of the measurement device to the low voltage cable shield (in the non-machine end of the cable).
2. Connect the other terminal of the measurement device to the machine enclosure grounding point.
3. Measure the resistance between the cable shield and the enclosure grounding point.

Anti-condensation heater connections



Do not run the electric machine when an anti-condensation heater is in use.

Water condensing inside the electric machine enclosure can result in failure or corrosion of the electric machine. This often happens in cooler temperatures or higher humidity areas typically in marine environment, when the machine is not running.

This electric machine can be fitted with a factory-assembled anti-condensation heater (+HEAT1) to prevent condensation. Do not operate the heater when the machine is powered or running.

A 230 V_{AC} power supply is required for the anti-condensation heater. The connection is made using a HUMMEL Twilock connector, shown in the figure below.

Connection of the heater element

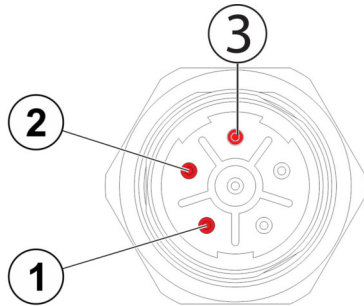







| | |
|---|----|
| 1 | L |
| 2 | N |
| 3 | PE |

If the electric machine has an anti-condensation heater and failure is suspected, contact Danfoss representative.

Operation

This chapter provides essential guidelines for safely and effectively operating the electric machine. It outlines the recommended operating conditions, monitoring practices, and emergency procedures to ensure optimal performance and longevity.

For electric machines with multiple winding systems (e.g., -DUAL or -QUAD), it must be verified during commissioning that each winding set rotates in the same direction.

| | |
|---|---|
|  | Only trained and qualified personnel familiar with the relevant safety requirements are allowed to operate the electric machine. |
|  | Do not use the electric machine without properly dimensioned and operating cooling system. Maximum operation temperature, current and rotational speed of the electric machine must not be exceeded to avoid permanent damage. |
|  | The surface of the electric machine might be hot. Do not touch the electric machine during operation. |
|  | Entanglement hazard! Do not touch the electric machine during operation. |
|  | Use the anti-condensation heater, if fitted, when the electric machine is not in use. This prevents condensation and possible damage to the electric machine. |
|  | Use sufficient personal protective equipment when you are near the electric machine. |
|  | Read the instructions in this user guide before you install the electric machine. |

Operation conditions

The electric machine should be used for its intended purpose only and within limits specified by the manufacturer, concerning:





- Loading.
- Cooling.
- Speed range.
- Service interval.
- Ambient condition such as temperature and moisture.

The electric machine is designed for the following conditions:

- Ambient temperature limits: -40°C...+65°C.
- Maximum altitude up to 4000 m above sea level. See the product data sheet for more information.
- Coolant liquid must be water-glycol mixture with maximum of 50 % glycol content. See Chapter *Recommended coolants*.
- For the maximum coolant liquid temperature at the inlet of the coolant circuit, see the product data sheet.

If electric machine operation limits are exceeded, please contact Danfoss representative.

Condition monitoring during operation

| | |
|---|---|
|  | Supervise the electric machine during operation to make sure that the electric machine operates correctly and has a designed lifetime. |
|  | If you notice any deviations from the normal operation, for example elevated temperatures, noise or vibration, stop the electric machine. Find the reason for the deviation and repair the electric machine. Refer to Chapter <i>Troubleshooting</i> on page 62. |
|  | Electrical safety of the system and the end application has to be guaranteed using appropriate methods, like external insulation resistance or residual current monitoring, depending on the application. |
|  | Maximum temperature of the bearings of the electric machine is: 120°C. |
|  | The maximum allowed winding temperature of the electric machine is shown on the rating plate and in the data sheet. |



Recommended lubricants

| | |
|---|--|
|  | Do not mix different types of lubricants! |
|---|--|

Greased for life bearings do not need relubrication during their lifetime. Grease relubricable bearings (BHS option) need regular greasing. For further information, see Chapter *Bearings and lubrication* on page 57.

The recommended grease type for the machine bearings is SKF LGHP-2 or equivalent. LGHP-2 is high performance, high temperature bearing grease. For further information, see <http://www.skf.com/>.

Recommended coolants

| | |
|---|--|
|  | Ethylene glycol is a toxic compound. Avoid exposure to the coolant. |
|  | Copper ions concentration of more than approx. 0.06 ppm causes <i>copper induced pitting corrosion</i>. Do not use copper components in the cooling system. |
|  | Use correct personal protective equipment when you handle the coolant. |

For optimal performance, use a water-based coolant with the electric machines. Suitable coolants include plain water with an appropriate corrosion inhibitor, or a 50/50 mixture of water and glycol with a corrosion inhibitor added.

Glycol coolant options:

- Ethylene glycol based Glysantin® G48® (includes also corrosion inhibitors).
- Propylene glycol-based coolants, like Splash® RV&Marine antifreeze.

Emergency operation

The electric machine should be operated within the operation limits and in the conditions specified by the manufacturer. However, it can be used with some limitations in the following fault/emergency situations.

Cooling of the electric machine fails

Cooling system failure can be caused by sediment accumulating in the cooling system tubes. Try opening the possible blockage by changing the coolant flow direction. See also Chapter *Cooling system maintenance*.





If the cooling of the electric machine fails, limited operation is still possible with no coolant flow. The operation speed must be limited to half (1/2) of the rated speed and maximum 20 % of the nominal torque may be used. In such case, the electric machine may be operated for maximum one hour. Repair the cooling system as soon as possible. For further information, contact Danfoss representative.

Danfoss service contact information



Contact Danfoss service at <https://danfosseditron.zendesk.com/hc/en-gb> or send email to editron.service@danfoss.com.

Maintenance

This Chapter contains necessary information for the qualified and trained personnel to carry out regular maintenance work.

| | |
|--|---|
|  | Do not disassemble the electric machine. Only procedures described in this user guide may be done. |
|  | Only trained and qualified personnel familiar with the relevant safety requirements are allowed to do maintenance to the electric machine. |
|  | Risk of electric shock when the connection box is open. Voltage may be connected to the anti-condensation heater. |
|  | Use correct personal protective equipment when you are near the electric machine. |
|  | Read the instructions in the user guide before you start to work with the electric machine. To make sure that the operation of the electric machine is safe and reliable, obey the maintenance instructions. |

Regular maintenance

| | |
|---|---|
|  | Inspect the electric machine at regular intervals. |
|  | Do not attempt to tighten bolts or screws that are not discussed in this user guide and that are not needed for normal installation and maintenance procedures. The sealing of the bolts and screws can break. |

Correct supervision and maintenance of the electric machine makes sure that the electric machine has reliable operation and designed lifetime.



Maintenance schedule

| Object | Check/Task | Weekly | Monthly | Yearly | |
|----------------------|-------------------------------|--|---------|--------|---|
| General construction | Operation | Noise, vibration. If clearly increased, contact Danfoss. | X | | |
| | Mounting | Bolt tightness. Tighten to proper value if necessary. Applies to bolts and screws that are discussed in this user guide. See Chapter <i>Tightening torques</i> . | | | X |
| | Bearings | Detect any unusual noise or vibration. If exists, contact Danfoss. | | | X |
| | Enclosure and connected parts | Check cleanliness. Clean if necessary. See Chapter <i>Cleaning</i> . | | X | |
| | Shaft seals | Check the wear. Replace if necessary. | | | X |

Maintenance schedule (continued)

| Object | | Check/Task | Weekly | Monthly | Yearly |
|-------------------|--|---|--------|---------|--------|
| Electrical system | Cables | Wearing of the cables. Replace if necessary. | | X | |
| | Electrical connections | Check connections. Make sure that tightening torque is correct for the cable glands. See Chapter <i>Tightening torques</i> . | | | X |
| | Groundings (earthings) | Check groundings (earthings). Make sure that the connection resistance is correct. Re-connect if necessary. | | | X |
| | Anti-condensation heater | Check anti-condensation heater connections and resistance, if the option is installed. If needed, contact Danfoss. | | | X |
| Cooling system | Operation | Functioning. Cooling system functions as specified. | X | | |
| | Tubing and connection tightness | No visible leakage. If leaking, tighten the connections, or replace parts. | | X | |
| | Ventilation plug | Cleanliness. Clean if necessary. See Chapter <i>Cleaning</i> . | | X | |
| | Coolant flow | Coolant flow direction. It is recommended to change the coolant flow direction by changing the connections or flow direction from the pump. See Chapter <i>Cooling system maintenance</i> . | | | X |
| | Coolant quality | Coolant as specified. Correct glycol used, and water/glycol mixture correct. Refill if necessary. See Chapter <i>Cooling system maintenance</i> . | | | X |
| Lubrication | Relubrication (grease lubricated bearings) | Relubricate depending on the use (see Chapter <i>Bearings and lubrication</i>). Maximum relubrication interval is six months. | | X | |

Cleaning

| | |
|---|--|
|  | To ensure watertight integrity and prevent water damage, never open or remove the ventilation plugs. Clean them only from the exterior surface. |
|  | Risk of electric shock if the electric machine is cleaned against instructions allowing water to go in to the electric machine. |

Keep the electric machine clean. For cleaning, use non-abrasive and non-corrosive cleaning products.

Make sure that the detergent may be used for aluminum.

When pressure washing the electric machine, make sure that the water spray does not directly hit the gaskets.

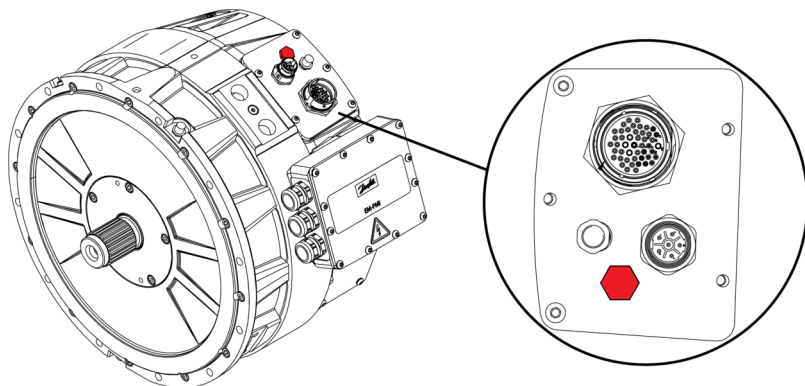

Ventilation plugs

Do not open/remove watertight ventilation plugs. Clean externally only.



Bearings and lubrication

Grease relubricable bearings

| | |
|---|---|
|  | Lubricants can cause skin irritation and eye inflammation. Follow all safety precautions specified by the manufacturer of the lubricant. |
|  | The bearing type of the electric machine can be found on the rating plate of the electric machine. |

Regular greasing is required for relubricable bearings. Follow the relubrication intervals and instructions outlined in this chapter.

It is recommended to have a piping for the grease exiting the electric machine. The grease exit hole is often in an inconvenient location when the electric machine is installed.

The mechanical bearing lifetime (grease relubricable bearings) of the electric machine is shown below. It depends on the bearing operation temperature and rotation speed.

Electric machine with grease relubricable bearing option

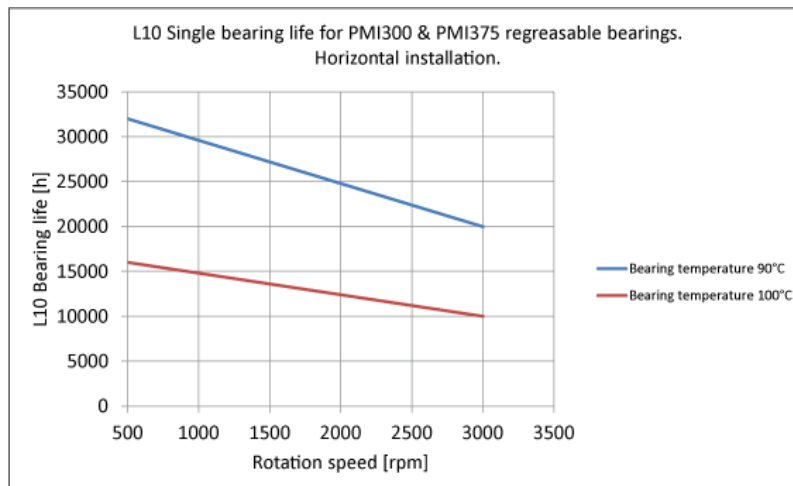

Bearing lifetime is typically expressed as L_{10} , which represents the point at which 90 % of the bearings are expected to remain reliable. Grease lubricated bearings (+BHS option) require regular greasing due to the limited lifespan of the grease itself, which is less than the bearing's potential lifespan.

The standard bearing type for EM-PMI375-T1100 is 6214/C3 (non-insulated bearing, grease lubricated). See the recommended lubricant in Chapter *Recommended lubricants* on page 53.

Greased for life bearings

Greased for life bearings (+BGL option) do not need relubrication during their lifetime.

The standard bearing type for EM-PMI375-T200, T500 and T800 is 6211-2RS1/C3WT (non-insulated bearing, greased for life) or SKF 6211 2RS1/HC5C3WT (insulated bearing).

Bearing lifetime is influenced by the electric machine's mounting position, rotation speed, and bearing temperature. The figures below illustrate the combined mechanical and grease lifetime of the bearing for both horizontal and vertical mounting configurations.

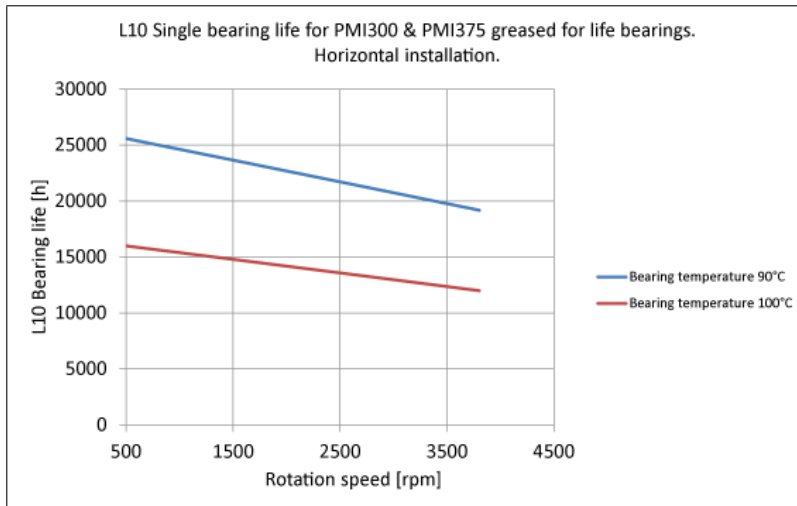
Bearing lifetime with greased for life bearings, horizontal mounting*Bearing lifetime with greased for life bearings, vertical mounting*

The expression of L_{10} in bearing grease lifetime information is a standard way of expressing the lifetime and it means the time period at the end of which 90 % of the bearings are still reliably lubricated and working.



The information of bearing lifetime and bearing grease lifetime are approximations only. The bearing lifetime and bearing grease lifetime in customer application may vary. Danfoss is not responsible for the actual bearing lifetime in use. For more information contact Danfoss.

Bearing relubrication

Beware of rotating parts. Do not touch the electric machine during operation.



The surface of the electric machine can be hot. Use correct protective equipment (heat resistant gloves) when you handle the electric machine.



The information of bearing lifetime and bearing grease lifetime are estimations only to provide a magnitude of them. The bearing lifetime and bearing grease lifetime in customer application may vary. Danfoss is not responsible for the actual bearing lifetime in use. For further information, contact Danfoss representative.



The maximum interval between relubrication cycles during operation is six months. Apply 20 g of grease per relubrication.

Relubrication intervals, which are dependent on rotation speed and bearing temperature, are shown in the figure below. Higher speeds and temperatures require more frequent relubrication. The figure displays curves for different bearing temperatures.

The maximum interval between relubrication cycles during operation is six months. Apply 20 grams of grease per relubrication.

Relubrication interval of the machine compared to rotation speed and bearing temperature

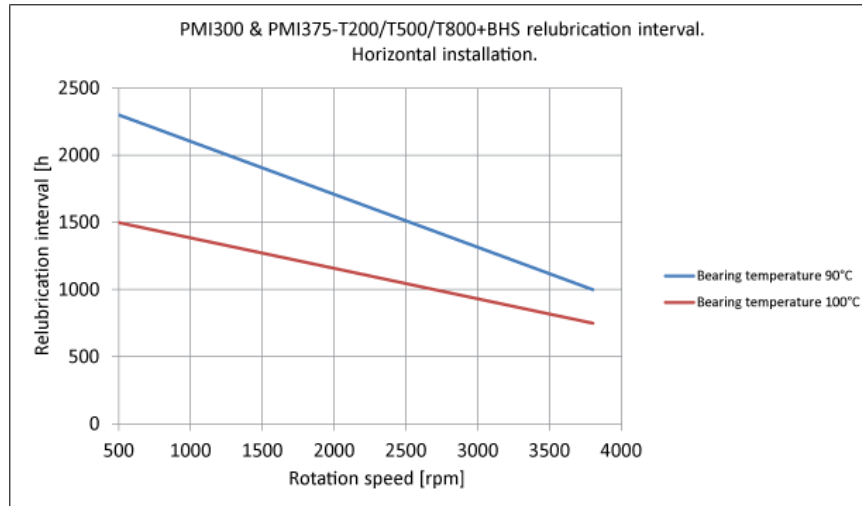

Relubrication interval of EM-PMI375-T1100 (+BHS option) compared to rotation speed and bearing temperature, horizontal installation

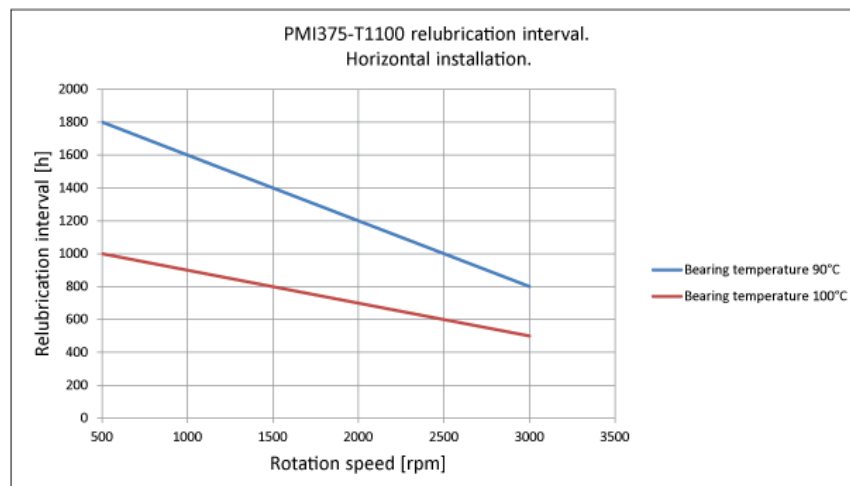

For more information about the location of grease nipples and grease escape holes, see Chapter *Connections and interfaces* on page 18.

Bearing relubrication:

It is normal if no grease exits the electric machine. This is because the cavities inside the electric machine can hold a lot of grease.

1. Make sure that the electric machine has reached its operating temperature.
2. Remove the plugs from the grease escape hole(s).
3. Open the grease nipple plug(s).
4. Use grease piston to enter specific amount of grease into the grease nipple.
5. If possible, let the electric machine run approximately one hour to let the old grease exit.
6. Install the plug(s) on the grease nipple(s) and on the grease escape hole(s).

Cooling system maintenance

It is recommended to change the direction of the coolant liquid flow yearly. This is done by changing the order of the coolant connections, or changing the coolant pump direction. The reason for changing the coolant flow direction is to prevent possible dregs (sediment) accumulating to the cooling system.

The quality of the coolant must be checked yearly. The mixture of coolant fluid must be according to specification. See Chapter *Recommended coolants*.

Dismounting



Make sure that the mating structure is not damaged. Do not pluck any bores or use at headed bolts or rods for pushing the electric machine out of the mating structure.

For dismounting the electric machine, follow the Steps below.

See Chapter *Mounting the electric machine* on page 34. Dismount the electric machine in reverse order.

1. Prepare the electric machine for lifting, for more information refer to Chapter *Lifting* on page 27. Support the electric machine with lifting slings when dismounting.
2. Loosen the mounting bolts. For more information refer to Chapter *Mounting the electric machine* on page 34.
3. Remove the surrounding supporting structures.
4. If force is required, use the bores in D-end flange to push the electric machine out from the mating structure, or use some other method that does not damage the electric machine.
5. Lift the electric machine off. Support the electric machine when lifting.

Troubleshooting

Some difficulties may occur while operating the electric machine. Possible causes and actions are given in the Table below. If the situation occurs, it should be corrected as soon as possible. These instructions do not cover all details or variations in the equipment nor provide information for every possible condition to be met in connection with installation, operation or maintenance.

For more information, contact Danfoss service at <https://danfosseditron.zendesk.com/hc/en-gb> or send email to editron.service@danfoss.com.

Troubleshooting chart

| Symptom | Possible cause | Action |
|------------------------------|---|--|
| Excessive vibration, noise | Imbalance at the connected electric machine or the powertrain components. | Check the balance and installation of the drivetrain components. |
| | Misalignment between the electric machine and the used device. | Check the shaft connections and couplings. Ensure that the alignment is within the specifications listed in Chapter <i>Shaft alignment and load</i> on page 24. |
| | Attachment bolts are loose. | Replace and tighten the bolts. |
| | Clearance at the spline connection. | Check the spline connection. |
| | Imbalance at the electric machine. | Contact local Danfoss representative. |
| | Particles inside the electric machine. | |
| | Bearing damage. | |
| | Inadequate lubrication (grease lubricated bearings). | Apply bearing lubricant/grease. See Chapter <i>Bearings and lubrication</i> . Contact local Danfoss representative for further information. |
| Bearing temperature rise | Inadequate lubrication (grease lubricated bearings). | Apply bearing lubricant/grease. See Chapter <i>Bearings and lubrication</i> . |
| | Too much grease in the bearing housing (grease lubricated bearings). | Open grease escape valve and let the electric machine run for 10 min. Clean the grease escape channel from solidified grease using brush if necessary. |
| | Incorrect bearing grease. | Check that the used grease is of correct type. |
| | Overloaded bearing. | Check that the system is not causing excess force or vibration to the machine bearings. Check the alignment of the machine shaft, see Chapter <i>Shaft alignment and load</i> on page 24. |
| | Bearing damage. | Contact local Danfoss representative for further information. |
| | Incorrect mounting option | Check motor mounting orientation and confirm that the motor has the correct option (vertical or horizontal mounting). |
| Electric machine overheating | Overload. | Reduce load. Check the machine rating plate and ensure that inverter limits are set accordingly. |
| | Cooling system failure. | Check the cooling system integrity, flow and fluid temperature. Change the cooling flow direction to flush the cooling system from sediment that has possibly accumulated. See also Chapter <i>Emergency operation</i> . |
| | Leakage in the cooling system. | Check the cooling system circuit and tighten the leaking connections. |
| | Rigid particle inside the machine cooling channel. | Try pulsating coolant to open the channels. Contact local Danfoss representative. |
| | Wrong machine parameters in the inverter. | Check and correct the machine parameters in the inverter. |
| | Damaged winding. | Measure the insulation resistance. Measure the winding resistance with a high-precision DC resistance meter and compare to manufacturer specifications. Replace the electric machine if necessary. |
| | Inverter switching frequency too low. | If other than a Danfoss Editron inverter is used, ensure that the switching frequency is at least equal to the required minimum switching frequency of the motor. See corresponding product data sheet. |

Troubleshooting chart (continued)

| Symptom | Possible cause | Action |
|--|--|--|
| Connection box and / or motor cables overheating | Cable lug bolts loose. | Check torque of cable lug bolts. See also Chapter <i>Power connections</i> on page 36. |
| | Cable diameter too small. | Replace power cables with appropriate cable type. |
| | Cable lug crimps insufficient or incorrect. | Replace cable lugs. Use recommended cable lugs and crimping tools. |
| | Contamination or insulating substance between cable lug and bus bar. | Check that the contact surfaces of the bus bars and cable lugs are clean and undamaged. Ensure there is no grease, thread locking compound, dirt or other foreign substances between the bus bar and cable lug. |
| Significant lubricant leak | Worn radial lip seal. | Contact local Danfoss representative. |
| | Block at the grease outlet channel. | Clean the grease escape channel from solidified grease using brush if necessary. |
| Electric machine does not work properly or the performance is poor | Wrong electric machine parameters in the inverter. | Check and correct the electric machine parameters from the inverter. See inverter user manual and other relevant documentation. |
| | Demagnetization of magnets due to overheating. | Check that the back-EMF of the motor is within specifications. Contact local Danfoss representative. Replace the electric machine if necessary. |
| | Bearing fault. | Check the bearing temperature, lubrication and conditions. Contact local Danfoss representative for further information. |
| | Insulation or winding fault. | Measure the insulation resistance, refer to the manufacturer limits. See Chapter <i>Insulation resistance test</i> . Measure the winding resistance with a high-precision DC resistance meter and compare to manufacturer specifications. Replace the electric machine if necessary. |
| Moisture and / or corrosion inside the connection box or motor | Cable glands installed incorrectly. | Check tightening torque and sealing of the cable glands. |
| | Power cables installed incorrectly. | Check cable installation and sealing with cable glands. |
| | Connection box cover bolts are too loose, too tight, or cover seal is damaged. | Check the integrity of the seal on the connection box cover. Tighten the cover bolts to the specified torque. |
| | Low voltage connector damaged or not connected. | Contact local Danfoss representative. |
| | Breather cap blocked. | Check that the breather cap of the electric machine is not submerged in liquid, painted, or covered by any object |
| Anti-condensation heater failure | The heater element is faulty. | Measure the resistance of the heater element. See Chapter <i>Anti-condensation heater connections</i> on page 51. If the heater is faulty, contact local Danfoss representative. |
| Temperature measurement failure | The PT100 sensor is faulty. | Measure the resistance of the PT100 sensor, see Chapter <i>Low voltage connections</i> . If the sensor is faulty, read out the signal from another sensor. Contact local Danfoss representative. See also Chapter <i>Emergency operation</i> . |
| Resolver sensor failure | Resolver wiring is faulty. | Check the wiring of the resolver and make sure that a shielded and twisted pair cable is used with the correct pairing of the signals. |
| | Resolver sensor is damaged. | Contact local Danfoss representative. |

Aftersales

Service policy

Maintenance and service of the electric machine is limited to the procedures described in this user guide.

If the electric machine has service parts available, you can find them in Chapter *Service parts* on page 64.

For further information, go to <https://danfosseditron.zendesk.com/hc/en-gb> or send email to editron.service@danfoss.com.

Service parts

The recommended service parts are listed in this Section. Maintenance procedures not described in this user guide require special tools and instructions. Contact Danfoss for more information and purchasing.

EM-PMI375-T200/T500/T800 Bearing kit (Non-insulated)

| Quantity (pcs) | Part | Type | Order number |
|--|---|---|--------------|
| EM-PMI375-T200/T500/T800-BEARING-KIT-NON-INSULATED | | | 11279474 |
| 1 | Washer | 55 x 68 x 3 DIN 988 | |
| 1 | Nut, lock | KM 11 | |
| 1 | Washer, locking (bearing nut) | MB 11 | |
| 1 | Spring, wave | LESJOFORS 4801 | |
| 1 | Seal, O-ring | 99,1 x 2,4 NBR70 | |
| 1 | Bearing, deep groove ball (non-insulated), Greased for life | SKF 6211 2RS1 C3 WT | |
| 1 | Nut, lock | KM11 | |
| 1 | Washer, locking (bearing nut) | MB11 | |
| 1 | Seal, O-ring | 99,1 x 2,4 NBR70 | |
| 1 | Bearing, deep groove ball (non-insulated), Greased for life | SKF 6211 2RS1 C3 WT | |
| 2 | Seal, radial lip, D-end (also N-end in +NE2) | 50 x 65 x 8 FKM, TRELLEBORG,TREA00500-VCBVR | |
| 1 | Seal, O-ring, D-end bearing shield | 158,34 x 3,53 NBR70 | |
| 1 | Seal, gasket, N-end cover plate | | |
| 5 | Bolt, socket head | M8 x 30 DIN 912 A4-80 | |
| 5 | Seal, washer | Bonded seals, U 8,7 x 13 x 1 | |
| 5 | Bolt, socket head | M8 x 25 DIN 912 A4-80 | |
| 1 | Wear sleeve | Speedi sleeve SKF 99196 | |

EM-PMI375-T200/T500/T800 Bearing kit (+BIN)

| Quantity (pcs) | Part | Type | Order number |
|--|---|---|--------------|
| EM-PMI375-T200/T500/T800-BEARING-KIT-BIN | | | 11279475 |
| 1 | Bearing, deep groove ball (insulated), Greased for life | SKF 6211 2RS1/HC5C3WT | |
| 1 | Washer | 55 x 68 x 3 DIN 988 | |
| 1 | Nut, lock | KM 11 | |
| 1 | Washer, locking (bearing nut) | MB 11 | |
| 1 | Spring, wave | LESJOFORS 4801 | |
| 1 | Seal, O-ring | 99,1 x 2,4 NBR70 | |
| 1 | Nut, lock | KM11 | |
| 1 | Washer, locking (bearing nut) | MB11 | |
| 1 | Seal, O-ring | 99,1 x 2,4 NBR70 | |
| 1 | Bearing, deep groove ball (non-insulated), Greased for life | SKF 6211 2RS1 C3 WT | |
| 2 | Seal, radial lip, D-end (also N-end in +NE2) | 50 x 65 x 8 FKM, TRELLEBORG,TREA00500-VCBVR | |
| 1 | Seal, O-ring, D-end bearing shield | 158,34 x 3,53 NBR70 | |
| 1 | Seal, gasket, N-end cover plate | | |
| 5 | Bolt, socket head | M8 x 30 DIN 912 A4-80 | |
| 5 | Seal, washer | Bonded seals, U 8,7 x 13 x 1 | |
| 5 | Bolt, socket head | M8 x 25 DIN 912 A4-80 | |
| 1 | Wear sleeve | Speedi sleeve SKF 99196 | |

EM-PMI375-T200/T500/T800 Bearing kit (+BHS)

| Quantity (pcs) | Part | Type | Order number |
|--|--|---|--------------|
| EM-PMI375-T200/T500/T800-BEARING-KIT-BHS | | | 11279477 |
| 1 | Washer | 55 x 68 x 3 DIN 988 | |
| 1 | Nut, lock | KM 11 | |
| 1 | Washer, locking (bearing nut) | MB 11 | |
| 1 | Bearing, deep groove ball (non-insulated), Grease lubricated (BHS) | 6211 C3 | |
| 1 | Spring, wave | LESJOFORS 4801 | |
| 1 | Seal, O-ring | 99,1 x 2,4 NBR70 | |
| 1 | Nut, lock | KM11 | |
| 1 | Washer, locking (bearing nut) | MB11 | |
| 1 | Bearing, deep groove ball (non-insulated), Grease lubricated (BHS) | 6211 C3 | |
| 1 | Seal, O-ring | 99,1 x 2,4 NBR70 | |
| 1 | Seal, radial lip, N-end (BHS option) | 72 x 72 x 8 TRELLEBORG, TRAB00520-4V012 | |
| 2 | Seal, radial lip, D-end (also N-end in +NE2) | 50 x 65 x 8 FKM, TRELLEBORG,TREA00500-VCBVR | |
| 1 | Seal, O-ring, D-end bearing shield | 158,34 x 3,53 NBR70 | |
| 1 | Seal, gasket, N-end cover plate | | |
| 1 | Seal, O-ring, N-end bearing shield (BHS option) | 99,1 x 2,4 NBR70 | |
| 5 | Bolt, socket head | M8 x 30 DIN 912 A4-80 | |
| 5 | Seal, washer | Bonded seals, U 8,7 x 13 x 1 | |
| 5 | Bolt, socket head | M8 x 25 DIN 912 A4-80 | |
| 1 | Wear sleeve | Speedi sleeve SKF 99196 | |

EM-PMI375-T200/T500/T800 Bearing kit (+BHS +BIN)

| Quantity (pcs) | Part | Type | Order number |
|--|--|--|--------------|
| EM-PMI375-T200/T500/T800-BEARING-KIT-BHS-BIN | | | 11279478 |
| 1 | Washer | 55 x 68 x 3 DIN 988 | |
| 1 | Nut, lock | KM 11 | |
| 1 | Washer, locking (bearing nut) | MB 11 | |
| 1 | Bearing, deep groove ball (insulated), Grease lubricated (BHS) | 6211 HC5C3 | |
| 1 | Spring, wave | LESJOFORS 4801 | |
| 1 | Seal, O-ring | 99,1 x 2,4 NBR70 | |
| 1 | Nut, lock | KM11 | |
| 1 | Washer, locking (bearing nut) | MB11 | |
| 1 | Bearing, deep groove ball (non-insulated), Grease lubricated (BHS) | 6211 C3 | |
| 1 | Seal, O-ring | 99,1 x 2,4 NBR70 | |
| 1 | Seal, radial lip, N-end (BHS option) | 72 x 72 x 8 TRELLEBORG, TRAB00520-4V012 | |
| 2 | Seal, radial lip, D-end (also N-end in +NE2) | 50 x 65 x 8 FKM, TRELLEBORG, TREA00500-VCBVR | |
| 1 | Seal, O-ring, D-end bearing shield | 158,34 x 3,53 NBR70 | |
| 1 | Seal, gasket, N-end cover plate | | |
| 1 | Seal, O-ring, N-end bearing shield (BHS option) | 99,1 x 2,4 NBR70 | |
| 5 | Bolt, socket head | M8 x 30 DIN 912 A4-80 | |
| 5 | Seal, washer | Bonded seals, U 8,7 x 13 x 1 | |
| 5 | Bolt, socket head | M8 x 25 DIN 912 A4-80 | |
| 1 | Wear sleeve | Speedi sleeve SKF 99196 | |

EM-PMI375-T200/T500/T800/T1100 Grease channel kit

| Quantity (pcs) | Part | Type | Order number |
|---|---------------------------------------|-------------------------------------|--------------|
| EM-PMI375-T200/T500/T800/T1100-GREASE-CHANNEL-KIT | | | 11279460 |
| 2 | Grease nipple (D/N-end) | DIN 71412, M8 x 1 | |
| 2 | Cover, grease nipple | Tecalemit 351010022 | |
| 2 | Plug for Grease escape hole (D/N-end) | M12 x 1,5 24-HFM-12 | |
| 2 | Plug for grease inlet hole | M8 x 1, 24-HFM-08 | |
| 1 | Plug, ventilation | Amphenol art. no. VENT-MS1NMS-O8001 | |

EM-PMI375-T200/T500/T800/T1100 Connection box cover kit

| Quantity (pcs) | Part | Type | Order number |
|---|--|----------------------------|--------------|
| EM-PMI375-T200/T500/T800/T1100-CONNECTION-BOX-COVER-KIT | | | 11279089 |
| 1 | Connection box cover plate (includes extruded sealant) | | |
| 12 | Bolt, socket head | M6 x 16 ISO 7380 A4-70 | |
| 1 | Sticker, EM-PMI | | |
| 1 | Sticker, Warning | High Voltage | |

EM-PMI375 Cable gland kit

| Quantity (pcs) | Part | Type | Order number |
|---------------------------|---------------------------------|-------------------------------|--------------|
| EM-PMI375-CABLE-GLAND-KIT | | | 11279473 |
| 3 | Cable gland (power connections) | M25 x 1,5 BG225MSTRI PFLITSCH | |

Disposal

Dispose of the electric machine and any of its parts by appropriate means in accordance with local laws and regulations.

Dispose of the product and any of its parts by appropriate means in accordance with local laws and regulations.

Storage, installation and maintenance checklists

Electric machine installation checklist

Date:

Electric machine and customer information

| | |
|----------------------------|---|
| Customer: | Electric machine type (from the rating plate): |
| Customer reference: | Electric machine serial number: |
| Service reference: | Date installed: |

N.A = Procedure not applicable PASS = Procedure passed FAIL = Procedure failed

Installation checklist

| | Approval | N.A | PASS | FAIL |
|---|--|--------------------------|--------------------------|--------------------------|
| General | | | | |
| Electric machine type is correct | | <input type="checkbox"/> | <input type="checkbox"/> | <input type="checkbox"/> |
| Electric machine is undamaged | | <input type="checkbox"/> | <input type="checkbox"/> | <input type="checkbox"/> |
| Insulation resistance check For more information, see Insulation resistance test on page 30. | Reference value of 500 MΩ must be exceeded at reference ambient temperature 25°C (measured with 500 V _{DC} / 1 min insulation resistance test). | <input type="checkbox"/> | <input type="checkbox"/> | <input type="checkbox"/> |
| Environmental conditions as specified (see data sheet) | | <input type="checkbox"/> | <input type="checkbox"/> | <input type="checkbox"/> |
| Mechanical installation | | | | |
| Supporting structure as required | | <input type="checkbox"/> | <input type="checkbox"/> | <input type="checkbox"/> |
| Shaft alignment as specified (see chapter Shaft alignment and load). | | <input type="checkbox"/> | <input type="checkbox"/> | <input type="checkbox"/> |
| D-end attachment bolt tightening torque | 40 Nm | <input type="checkbox"/> | <input type="checkbox"/> | <input type="checkbox"/> |
| N-end attachment bolt tightening torque | 30 Nm | <input type="checkbox"/> | <input type="checkbox"/> | <input type="checkbox"/> |
| Cooling circuit connected and coolant flowing | | <input type="checkbox"/> | <input type="checkbox"/> | <input type="checkbox"/> |
| Used coolant: | | | | |
| Power connections | | | | |
| Cable gland assembly as specified (cable gland to cables) with correct cable diameter | | <input type="checkbox"/> | <input type="checkbox"/> | <input type="checkbox"/> |
| Cable lug air cap (to metallic structures) | ≥10 mm | <input type="checkbox"/> | <input type="checkbox"/> | <input type="checkbox"/> |
| Cable gland tightening torque (to the box) | 15 Nm | <input type="checkbox"/> | <input type="checkbox"/> | <input type="checkbox"/> |
| Cable lug tightening torque (to the bus bar) | 15 Nm | <input type="checkbox"/> | <input type="checkbox"/> | <input type="checkbox"/> |
| The phase connections order is correct (U, V, W -> L1, L2, L3) | | <input type="checkbox"/> | <input type="checkbox"/> | <input type="checkbox"/> |
| Connection box cover bolts tightening torque | 4 Nm | <input type="checkbox"/> | <input type="checkbox"/> | <input type="checkbox"/> |
| Grounding | | | | |

Installation checklist (continued)

| | Approval | N.A | PASS | FAIL |
|---|----------|--------------------------|--------------------------|--------------------------|
| Electric machine enclosure grounding connected | | <input type="checkbox"/> | <input type="checkbox"/> | <input type="checkbox"/> |
| Low voltage cable shield grounding connected | | <input type="checkbox"/> | <input type="checkbox"/> | <input type="checkbox"/> |
| Power cable shield connection resistances to ground (electric machine enclosure) measured and valid | | <input type="checkbox"/> | <input type="checkbox"/> | <input type="checkbox"/> |
| Low voltage cable shield grounding resistances measured and valid | | <input type="checkbox"/> | <input type="checkbox"/> | <input type="checkbox"/> |
| Notes: <ul style="list-style-type: none"> • • • • • • • • • • • • • • Date: Signature: | | | | |

Do not try to tighten bolts or screws that are not discussed in the product manual and that are not needed for the normal installation procedures. Sealing of the screws may break.

Electric machine weekly maintenance checklist

Date:

Electric machine and customer information

| | |
|----------------------------|---|
| Customer: | Electric machine type (from the rating plate): |
| Customer reference: | Electric machine serial number: |
| Service reference: | Date installed: |

N.A = Procedure not applicable PASS = Procedure passed FAIL = Procedure failed

Electric machine weekly maintenance checklist

| | N.A | PASS | FAIL |
|--|--------------------------|--------------------------|--------------------------|
| General construction | | | |
| Noise or vibration during operation in general | <input type="checkbox"/> | <input type="checkbox"/> | <input type="checkbox"/> |
| Cooling system | | | |

Electric machine weekly maintenance checklist (continued)

| | N.A | PASS | FAIL |
|---|--------------------------|--------------------------|--------------------------|
| Functioning of the cooling system in general | <input type="checkbox"/> | <input type="checkbox"/> | <input type="checkbox"/> |
| Notes: | | | |
| <ul style="list-style-type: none"> • • • • • • • • • • • | | | |

Electric machine monthly maintenance checklist**Date:***Electric machine and customer information*

| | |
|----------------------------|---|
| Customer: | Electric machine type (from the rating plate): |
| Customer reference: | Electric machine serial number: |
| Service reference: | Date installed: |

N.A = Procedure not applicable PASS = Procedure passed FAIL = Procedure failed

Electric machine monthly maintenance checklist

| | N.A | PASS | FAIL |
|--|--|--------------------------|--------------------------|
| General construction | | | |
| Noise or vibration during operation in general | <input type="checkbox"/> | <input type="checkbox"/> | <input type="checkbox"/> |
| Cleanliness of the enclosure and connected parts | <input type="checkbox"/> | <input type="checkbox"/> | <input type="checkbox"/> |
| Electrical system | | | |
| Weariness of the cables | <input type="checkbox"/> | <input type="checkbox"/> | <input type="checkbox"/> |
| Insulation monitoring | Continuous insulation monitoring. (It is recommended to use continuous insulation monitoring for the whole system where electric machine is used.) | | |
| Encoder mounting | <input type="checkbox"/> | <input type="checkbox"/> | <input type="checkbox"/> |
| Cooling system | | | |
| Functioning of the cooling system in general | <input type="checkbox"/> | <input type="checkbox"/> | <input type="checkbox"/> |
| Tightness of the ventilation plug | <input type="checkbox"/> | <input type="checkbox"/> | <input type="checkbox"/> |

Electric machine monthly maintenance checklist (continued)

| | N.A | PASS | FAIL |
|---|--------------------------|--------------------------|--------------------------|
| Cleanliness of the ventilation plug | <input type="checkbox"/> | <input type="checkbox"/> | <input type="checkbox"/> |
| Notes: | | | |
| <ul style="list-style-type: none"> • • • • • • • • • • • • • • • | | | |

Electric machine yearly maintenance checklist

Date:

Electric machine and customer information

| | |
|----------------------------|---|
| Customer: | Electric machine type (from the rating plate): |
| Customer reference: | Electric machine serial number: |
| Service reference: | Date installed: |

N.A = Procedure not applicable PASS = Procedure passed FAIL = Procedure failed

Electric machine yearly maintenance checklist

| | Acceptance | N.A | PASS | FAIL |
|---|------------|--------------------------|--------------------------|--------------------------|
| General construction | | | | |
| Noise or vibration during operation in general | | <input type="checkbox"/> | <input type="checkbox"/> | <input type="checkbox"/> |
| Mounting bolt tightness | | | | |
| D-end attachment bolt tightening torque | 40 Nm | <input type="checkbox"/> | <input type="checkbox"/> | <input type="checkbox"/> |
| N-end attachment bolt tightening torque | 30 Nm | <input type="checkbox"/> | <input type="checkbox"/> | <input type="checkbox"/> |
| Cleanliness of the enclosure and connected parts | | <input type="checkbox"/> | <input type="checkbox"/> | <input type="checkbox"/> |
| Electrical system | | | | |
| Weariness of the cables | | <input type="checkbox"/> | <input type="checkbox"/> | <input type="checkbox"/> |
| Electrical connections in general | | <input type="checkbox"/> | <input type="checkbox"/> | <input type="checkbox"/> |
| Cable gland tightening torque (to the box) | 15 Nm | <input type="checkbox"/> | <input type="checkbox"/> | <input type="checkbox"/> |
| Cable lug tightening torque (to the bus bar) | 15 Nm | <input type="checkbox"/> | <input type="checkbox"/> | <input type="checkbox"/> |
| Connection box cover bolts tightening torque | 4 Nm | <input type="checkbox"/> | <input type="checkbox"/> | <input type="checkbox"/> |
| Cooling system | | | | |
| Coolant quality as specified | | <input type="checkbox"/> | <input type="checkbox"/> | <input type="checkbox"/> |
| Used coolant: | | | | |
| Functioning of the cooling system in general | | <input type="checkbox"/> | <input type="checkbox"/> | <input type="checkbox"/> |
| Tightness of the tubing and connections (no leakages) | | <input type="checkbox"/> | <input type="checkbox"/> | <input type="checkbox"/> |

Electric machine yearly maintenance checklist (continued)

| | Acceptance | N.A | PASS | FAIL |
|---|--------------------------|--------------------------|--------------------------|--------------------------|
| Cleanliness of the ventilation plug | <input type="checkbox"/> | <input type="checkbox"/> | <input type="checkbox"/> | <input type="checkbox"/> |
| Grounding | | | | |
| Power cable shield connection resistances to ground (electric machine enclosure) checked | <input type="checkbox"/> | <input type="checkbox"/> | <input type="checkbox"/> | <input type="checkbox"/> |
| Low voltage cable shield grounding resistances checked | <input type="checkbox"/> | <input type="checkbox"/> | <input type="checkbox"/> | <input type="checkbox"/> |
| Connection to grounding points checked | <input type="checkbox"/> | <input type="checkbox"/> | <input type="checkbox"/> | <input type="checkbox"/> |
| Notes: | | | | |
| <ul style="list-style-type: none"> • • • • • • • • • • • • • • • | | | | |

Do not try to tighten bolts or screws that are not discussed in the product manual and that are not needed for the normal installation procedures. Sealing of the screws may break.

For cleaning instructions, refer to Chapter *Cleaning* on page 56.

Used service parts

| Part description | Part type | Quantity | Item (order) number |
|---|-----------|----------|---------------------|
| – | | | |
| – | | | |
| – | | | |
| – | | | |
| – | | | |
| Notes: | | | |
| <ul style="list-style-type: none"> • • • • • • • • • • • • • • • | | | |
| Date: | | | |
| Signature: | | | |

Electric machine storage checklist

Date:

Electric machine and customer information

| | |
|----------------------------|---|
| Customer: | Electric machine type (from the rating plate): |
| Customer reference: | Electric machine serial number: |
| Service reference: | Date installed: |

This storage checklist is used when storing the electric machine. Regular inspection is required. See specifications for storage in this User Guide or in the Data Sheet.

Fill in the date of each inspection to the Table below.

Storage checklist

| Procedure | Date | Date | Date | Date | Date |
|---|------|------|------|------|------|
| Storage base as specified (vibration free) | | | | | |
| Storage temperature and humidity as specified | | | | | |
| Electric machine type and serial number is correct | | | | | |
| Electric machine supported correctly | | | | | |
| Corrosion protection of non-painted surfaces (for example shaft-end and grounding points) | | | | | |
| Insulation resistance (test insulation resistance every three months in storage) | | | | | |
| Shaft rotated as specified (10 rotations monthly) | | | | | |



Hydro-Gear

www.hydro-gear.com

Daikin-Sauer-Danfoss

www.daikin-sauer-danfoss.com

Explore our solutions at danfoss.com.

Additional product literature is available at powersource.danfoss.com.

**Danfoss
Power Solutions (US) Company**
2800 East 13th Street
Ames, IA 50010, USA
Phone: +1 515 239 6000

**Danfoss
Power Solutions GmbH & Co. OHG**
Krokamp 35
D-24539 Neumünster, Germany
Phone: +49 4321 871 0

**Danfoss
Power Solutions ApS**
Nordborgvej 81
DK-6430 Nordborg, Denmark
Phone: +45 7488 2222

**Danfoss
Power Solutions Trading
(Shanghai) Co., Ltd.**
Building #22, No. 1000 Jin Hai Rd
Jin Qiao, Pudong New District
Shanghai, China 201206
Phone: +86 21 2080 6201

Danfoss can accept no responsibility for possible errors in catalogues, brochures and other printed material. Danfoss reserves the right to alter its products without notice. This also applies to products already on order provided that such alterations can be made without subsequent changes being necessary in specifications already agreed.
All trademarks in this material are property of the respective companies. Danfoss and the Danfoss logotype are trademarks of Danfoss A/S. All rights reserved.
