

Data Sheet

ED3

EC-BDC1200

Liquid cooled onboard charger and electric power take-off

FEATURES

- Enclosure with high degree of protection from ingress (IP6K9K) – sealed from moisture and dust
- Efficiency up to 96 %
- Liquid cooled with water-glycol mixture
- Ambient temperature range of -40°C and +85°C
- Allowed coolant temperature up to +70°C
- Robust design withstanding high levels of mechanical vibration and shocks
- Support for single and three phase charging at 63 A_{RMS} up to 43.6 kVA
- DC power take-off up to 44 kW
- AC power take-off up to 43.6 kVA

SOFTWARE FEATURES

- J1939 compliant Danfoss proprietary CAN interface
- Bidirectional energy flow control
- High performance current and voltage control
- Wide selection of protective functions



GENERAL

The device is an onboard charger designed specifically for the charging of electric and hybrid commercial vehicles and off-highway work machines. It can also be used as an electric power take-off for supplying AC or DC voltage to auxiliary equipment.

TYPICAL APPLICATIONS

- Onboard charger for high voltage battery of electric vehicle and off-highway machinery
- AC power take-off for single and three phase auxiliary loads, usable during vehicle or machine operation
- DC power take-off for HVAC or heaters, usable during vehicle or machine operation

SPECIFICATIONS

DC-link connection	
DC-link voltage range	500 - 800 V _{DC}
Derated DC-link voltage range	450 - 499 V _{DC} (linear power derating 20 - 100 % from 500 V _{DC} values)
Maximum charging power	41.6 kW (see performance curves below)

AC-In connection	
AC input voltage	1-phase 90 - 293 V 3-phase 156 - 507 V Only in combination with functional 30 mA Type B RCD while charging from TN network with and without neutral. Only in combination with functional IMD while charging from IT network with or without neutral. Charging is prohibited from corner grounded networks.
Frequency	50 Hz ±2 Hz, 60 Hz ±2 Hz
Maximum power	43.6 kVA (see performance curves below)
Maximum input current	63 A per phase
Maximum THD (current)	< 4 %

AC-Out connection (AC ePTO)	
AC output voltage	3-phase 380 - 481 V Single and unbalanced three phase load support. Supply into IT network only in combination with an IMD. Supply into TN network prohibited.
Output voltage accuracy	±2 %
Maximum power	43.6 kVA (see performance curves below)
Nominal current	63 A per phase
Maximum peak current	126 A per phase for 500 ms (see user guide for eFuse functionality)
Output frequency	50 or 60 Hz
Maximum THD (voltage)	< 2 %

DC-Out connection (DC ePTO)	
DC output voltage	500 - 850 V ±2 % Only in combination with an IMD.
Output voltage accuracy	±2 %
Maximum output power	44 kW (see performance curves below)
Nominal current	59 A per phase
Maximum peak current	118 A per phase for 10 ms (see user guide for eFuse functionality)

Efficiency	
Charging	Up to 95.3 %
AC electric power take-off	Up to 94.9 %
DC electric power take-off	Up to 96.8 %

Control voltage input	
Voltage range	8 - 32 V _{DC}
Nominal voltage	1.3 A _{DC} @ 24 V _{DC}
Continuous maximum power	Operation: < 33 W Enabled: < 28 W Standby: < 13.5 W Sleep: < 1.1 mW

Mechanical	
Dimensions (W x H x L, mm)	518 x 453 x 166 mm
Volume	35.7 l ±2 %
Weight	45 kg ±1.1 %
Main materials	Enclosure: EN AC-43400 (EN AC-AISI10Mg (Fe))
Surface treatment	Passivation

Cooling	
Cooling liquid	Water-glycol mixture (nominal 50 %, max. 60 % corrosive inhibitor) (see user guide for more information)
Cooling liquid glycol type	Ethylene glycol (see user guide for the approved types)
Nominal cooling liquid flow	10 l/min
Maximum continuous pressure	3 bar
Lowest absolute pressure	1 kPa (for vacuum filling)
Coolant volume	1.75 l +/-0.1 l
Pressure loss	126 mbar with 10 l/min (+25°C coolant)
Cooling liquid temperature	-40°C...+70°C Coolant temperature may lead to derating of the device (see performance curves below)

Ambient conditions	
Storage temperature	-40°C...+85°C
Operating temperature	-40°C...+85°C Ambient operating temperature may lead to derating of the device (see performance curves below)
Altitude	max. 3000 m
Relative humidity	93 %
Enclosure class	IP6K9K with all external connectors mated IP34 without connectors
Mechanical impact	IK08 according to IEC 62262, 60068-2-75:1997 and SFS-EN 62262:2011
Mechanical vibration	ISO 16750-3:2023 Test XVI: Random vibration of large/heavy DUT's, Sprung masses in hybrid/electric commercial vehicle
Mechanical shock	ISO 16750-3:2023 4.2.2 Test for devices on rigid points on the body and on the frame

Connections	
Coolant connection	M22 x 1.5 internal thread
HV cable recommended type	HUBER+SUHNER Radox Elastomer S, screened, single core, automotive cable (FHLR4GC13X) https://www.hubersuhner.com
HV cable cross section	AC-In, AC-Out – 10 mm ² DC-Out – 16 mm ² HV Battery – 50 mm ²
AC _{IN} connector	Amphenol ELR4A04
AC _{IN} mating connector	Amphenol ELP4A04
AC _{OUT} connector	Amphenol ELR4Z04
AC _{OUT} mating connector	Amphenol ELP4Z04
DC _{OUT} connector	Amphenol ELRA2Y03
DC _{OUT} mating connector	Amphenol ELPA2Y16
DC-link connector	Amphenol PL082X-301-10M8
DC-link mating connector	Amphenol straight: PL182X-301-70/50/35 (depending on cable diameter) Do not order PL182X-301-70/50/35-2-5. Amphenol right-angled: PL282X-301-70/50/35 (depending on cable diameter) Do not order PL282X-301-70/50/35-2-5. IEC 60228 Class 5 conductor connectors are also available (see manufacturer documentation). https://www.amphenol-industrial.de
Signal connector	TE 1534238-1
Signal connector mating connector	TE 1-1534127-1
Signal mating connector pin and seals	Pins: 0.5 - 1.0 mm ² TE 1-968855-2 Wire seal: TE 828904-1 Sealing plug for empty cavities: TE 828922-1 Backshell: TE 9-1394050-1
Signal connector pin configuration	See section SIGNAL CONNECTOR PINOUT
CAN connections	Non-isolated CAN channel with configurable termination
CAN protocol	SAE J-1939

Protections	
SW overcurrent trip	Yes
SW overvoltage trip	Yes
Short circuit protection	Yes
High voltage interlock loop	Yes, with monitoring (see user guide for more information)
Converter temperature protection	Sophisticated thermal model that can automatically lower the current if needed
Converter temperature trip	Yes
eFuse	Yes, for AC-In, AC-Out and DC-Out

Standards and classifications	
EN 61851-21-1: 2017 Electric vehicle conductive charging system – Part 21-1: Electric vehicle onboard charger EMC requirements for conductive connection to AC/DC supply	
UN Regulation No. 10 Revision 6 *) Uniform provisions concerning the approval of vehicles with regards to electromagnetic compatibility.	

*) EMI-filter EC-BDF1200-63 is required to fulfill the UN ECE R10 regulation for charging. AC-out and DC-out fulfill the regulation without EC-BDF1200 filter.

DERATING CURVES – CHARGING

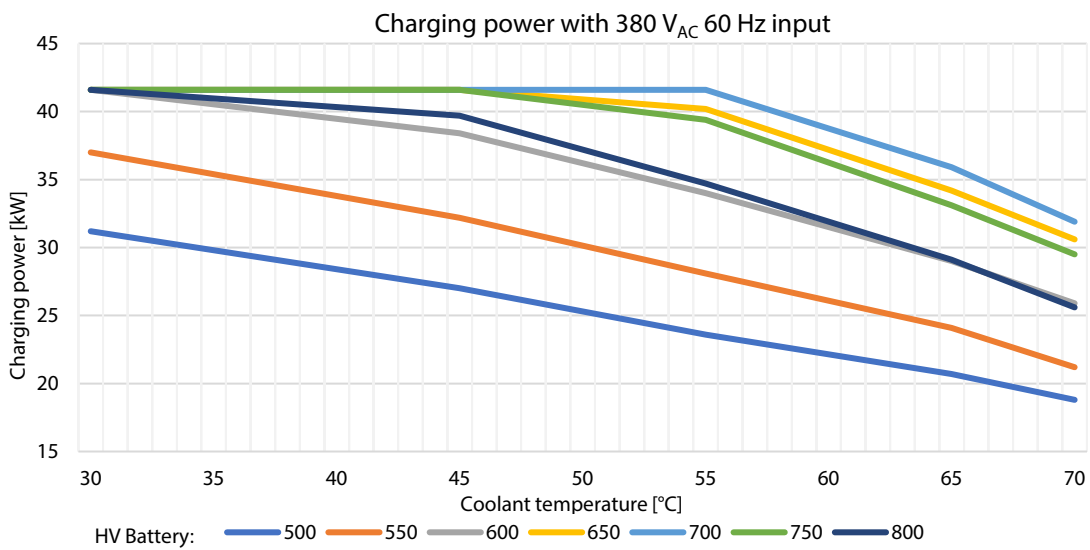
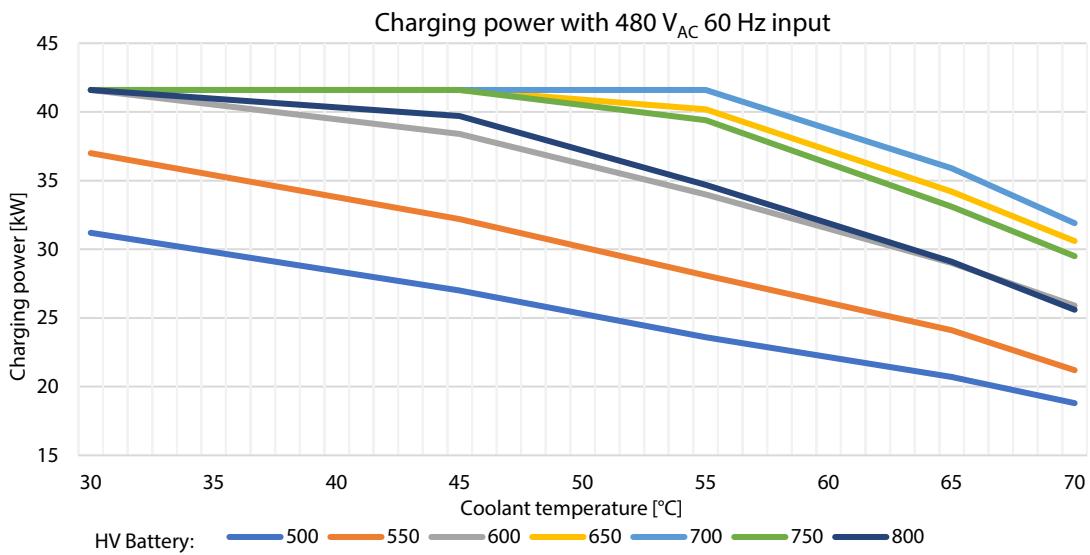
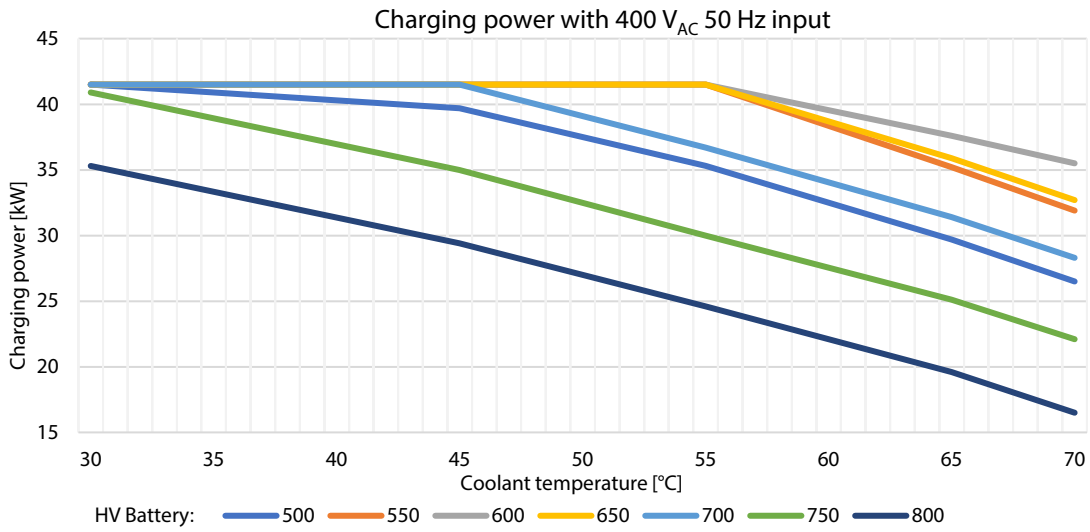

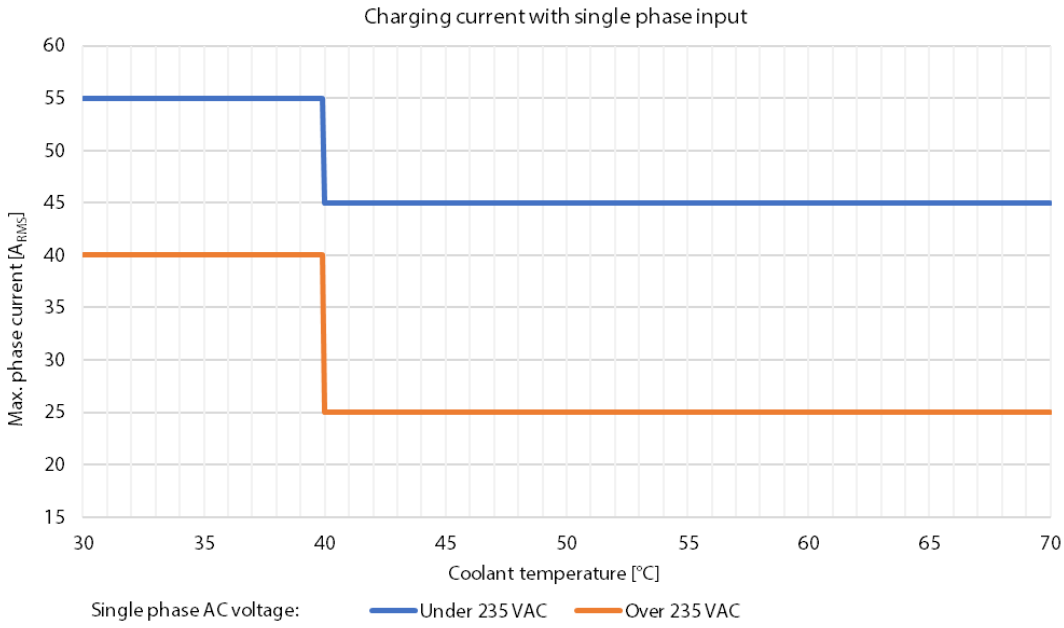

DERATING CURVES – DC-OUT

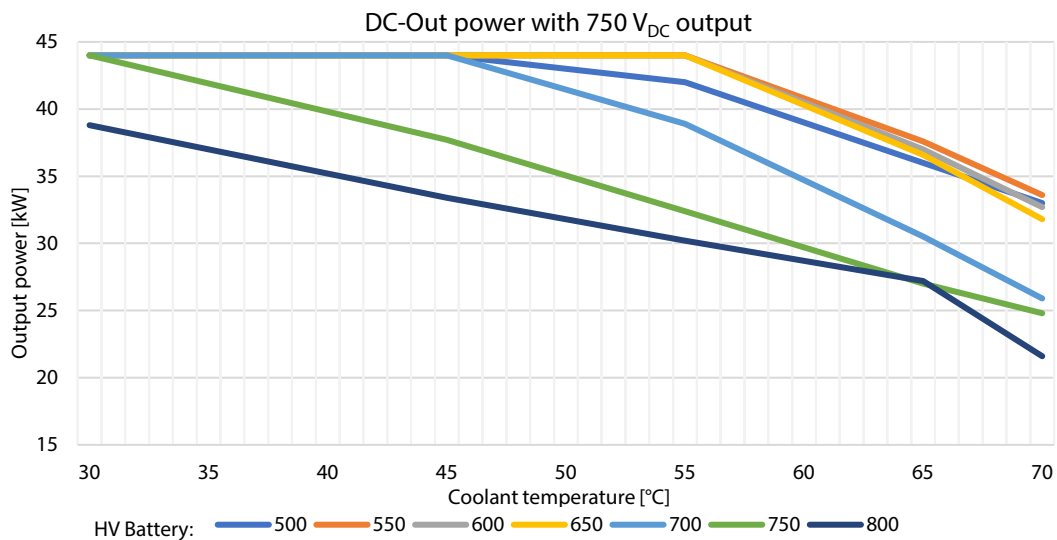
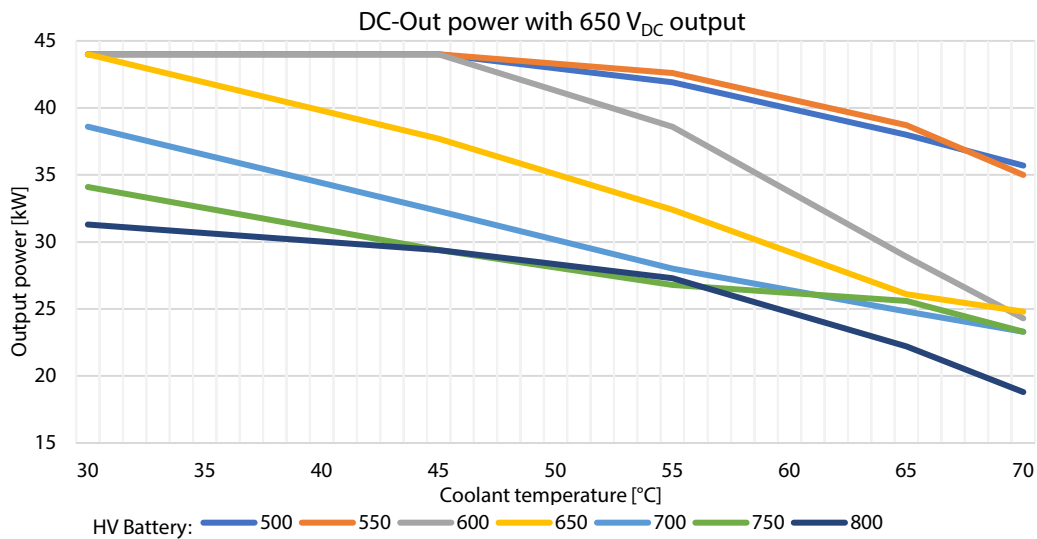

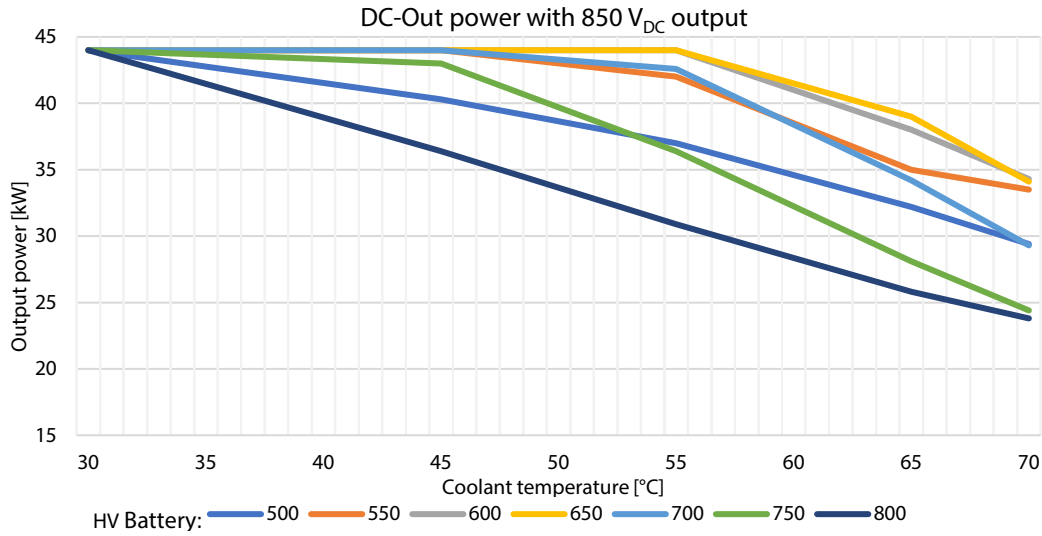

DERATING CURVES – AC-OUT

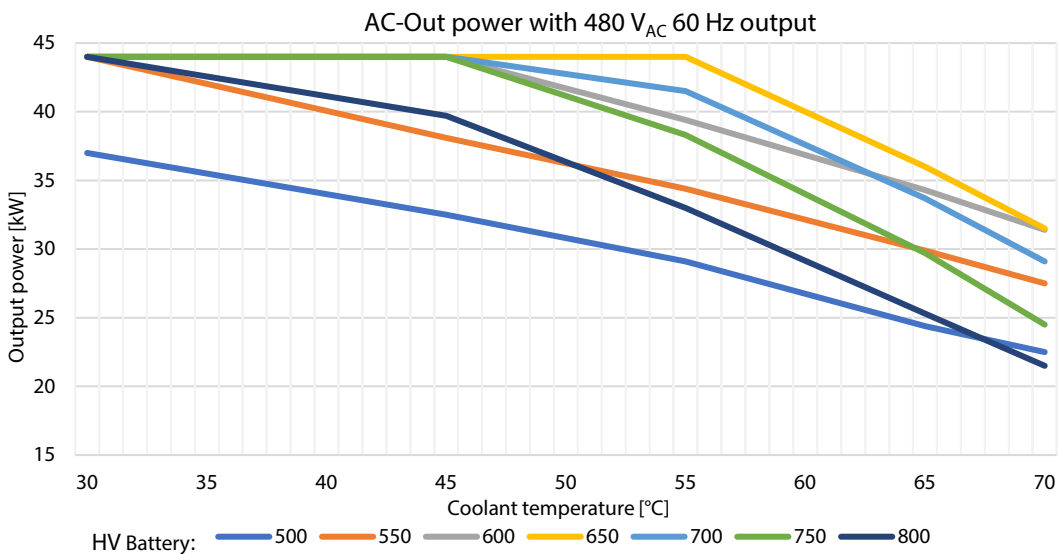
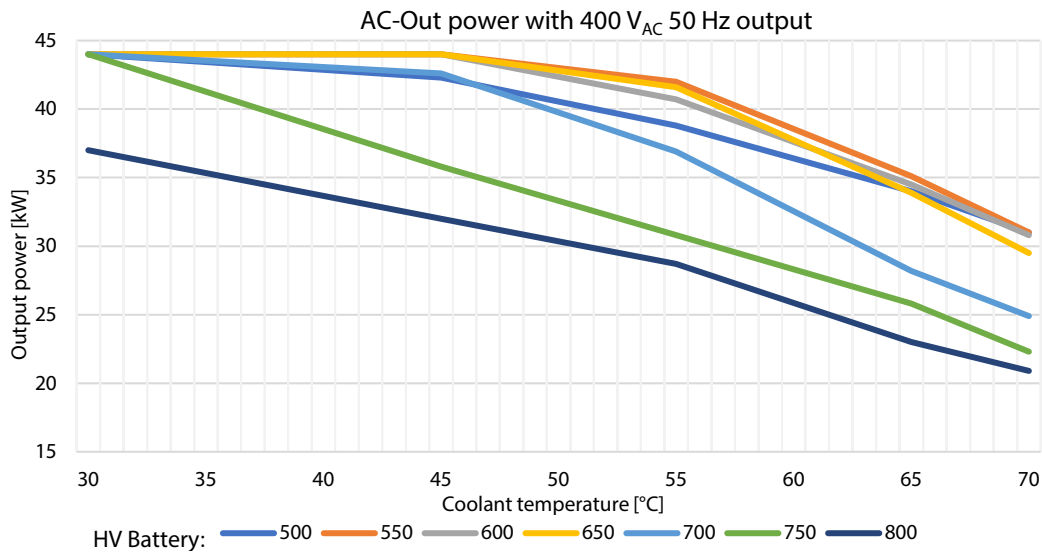

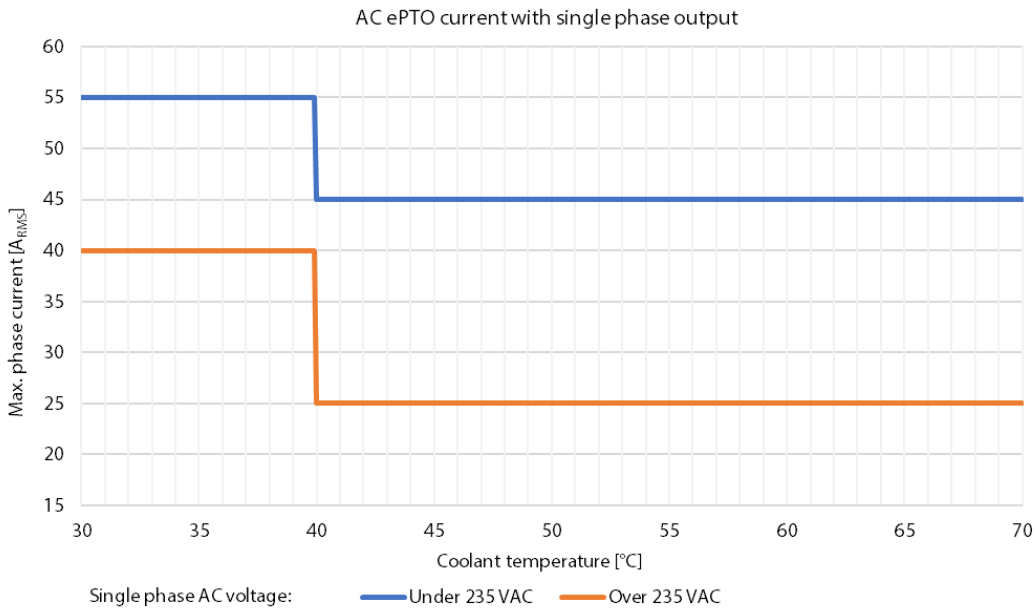

PRESSURE LOSS VS COOLANT FLOW (+25°C coolant)

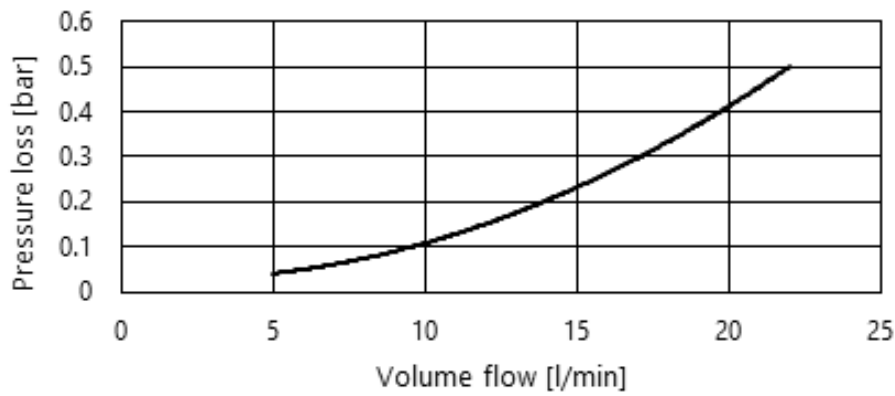

DIMENSIONS

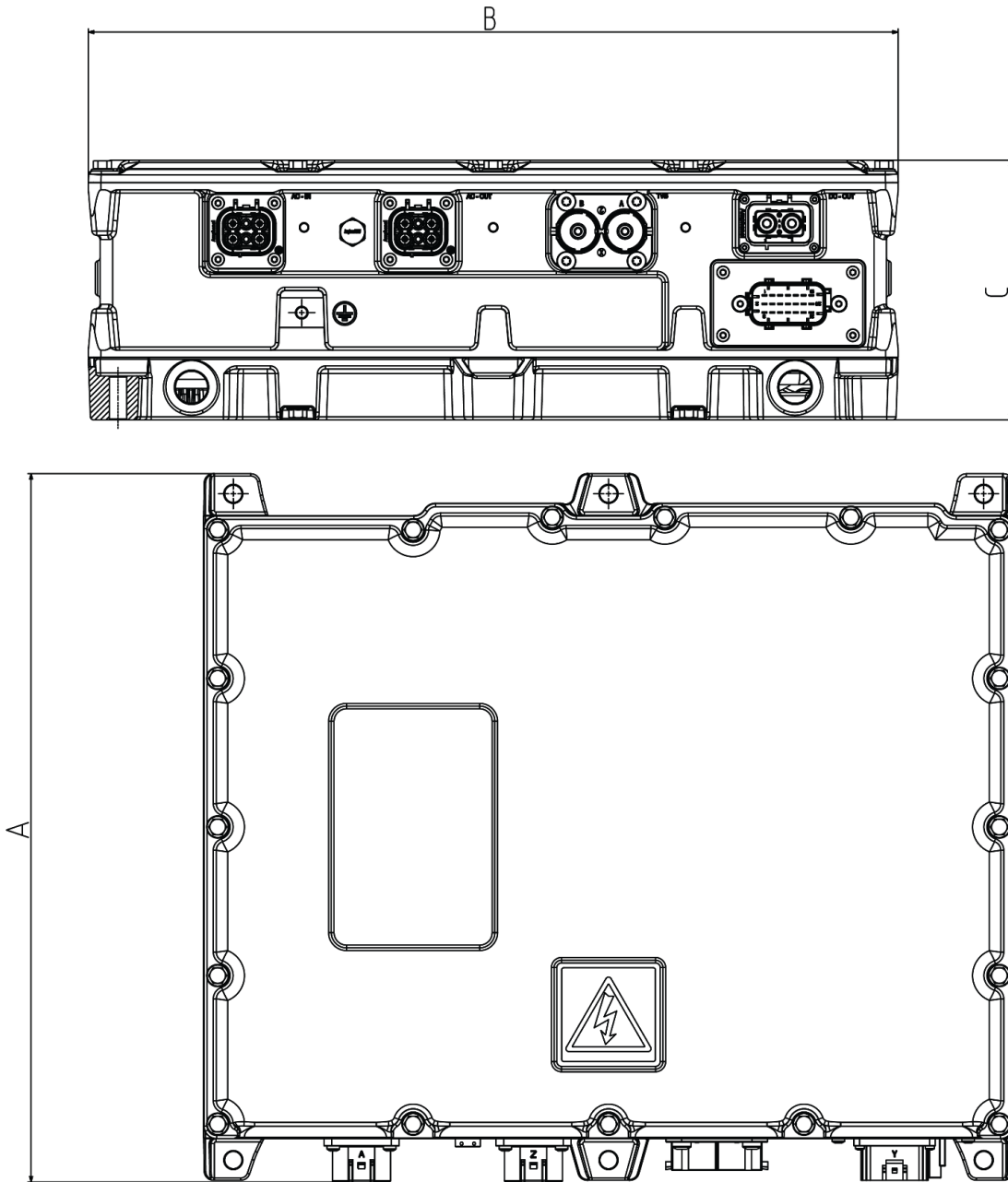

Picture 1 Device dimensions

Dimension	EC-BDC1200
A	453 mm
B	518 mm
C	166 mm

INTERNAL SCHEMATIC AND COMPONENTS

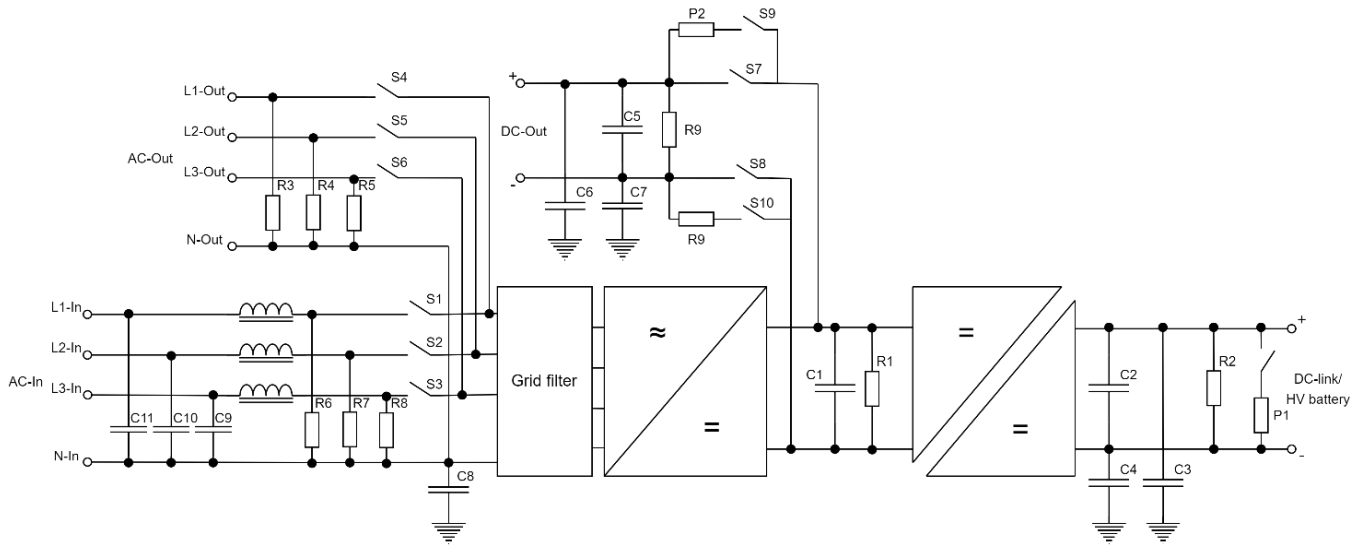

Picture 2 Internal schematic and components (the drawing is simplified to display only the relevant parts)

Component	Description
Internal DC bus capacitance C1	400 μ F
Internal DC bus resistance R1	250 k Ω
AC-In and AC-Out discharge resistance R3, R4, R5, R6, R7, R8	100 k Ω
AC-In and AC-Out Y-capacitance C8	1 μ F
AC-In X-capacitance C9-C11	20 μ F
DC-link X-capacitance C2	240 μ F
DC-link Y-capacitance C3, C4	3.3 nF
DC-link discharge resistance R2	500 k Ω
DC-Out Y-capacitance C6, C7	3.3 nF
DC-Out X-capacitance C5	1 μ F
DC-Out discharge resistance R9	500 k Ω
Semiconductor switches S1-S10	NA
Insulation resistance	> 50 M Ω

APPLICATION EXAMPLE



Picture 3 EC-BDC1200 application example with EMI filter EC-BDF1200-63

*) UNECE R10 compliance for charging is reached at the component level when EC-BDF1200-63 filter is used. For more information, see EC-BDF1200-63 data sheet.

SIGNAL CONNECTOR PINOUT

PIN	Signal name	Description
1	CANH_A	CAN bus A high
2	CANL_A	CAN bus A low
3	VIN_P	Positive Power Supply (8-32 V)
4	CAN ID REF 1	CAN ID reference 1. Reference pin that can be used to set CAN ID input HIGH.
5	CAN ID REF 2	CAN ID reference 2. Reference pin that can be used to set CAN ID input LOW.
6	VIN_N/GND	Negative Power Supply (0 V)
7	WAKE_UP	Rising edge enables the device communication but only allows operation mode Charging. Ignored after enable has been received. See ED3 Software manual for shutdown. Active rising edge, Turn ON @> 5.46 V, Turn OFF < 4.52 V. Current draw is 8-11 mA.
8	HVIL_IN	High voltage internal lock input for DC-link connector. Current between 8-30 mA must be supplied externally to allow charging. 4.7 Ω resistor between HVIL_IN and HVIL_OUT pins.
9	HVIL_OUT	High voltage internal lock output for DC-link connector.
10	CAN_A TERM 1	Termination of CAN bus A, Connect to CANH_A to connect the termination resistor. Can be left unconnected if external termination is used.
11	CAN_A TERM 2	Termination of CAN bus A, Connect to CANL_A to connect the termination resistor. Can be left unconnected if external termination is used.
12	CAN ID 1	CAN A source address and PGN configuration input 1 Short to supply > 16.07 V 1 = 7.86 - 16.07 V 0 = 4.28 - 7.86 V Open circuit = 4.28 - 2.14 V Short to ground < 2.14 V Input resistance 220 Ω
13	Reserved	
14	Reserved	
15	CAN ID 2	CAN A source address and PGN configuration input 2 Short to supply > 16.07 V 1 = 7.86 - 16.07 V 0 = 4.28 - 7.86 V Open circuit = 4.28 - 2.14 V Short to ground < 2.14 V Input resistance 220 Ω
16	Reserved	
17	Reserved	
18	CAN ID 3	CAN A source address and PGN configuration input 3 Short to supply > 16.07 V 1 = 7.86 - 16.07 V 0 = 4.28 - 7.86 V Open circuit = 4.28 - 2.14 V Short to ground < 2.14 V Input resistance 220 Ω
19	Reserved	
20	Reserved	
21	EPTO_ENABLE	Enables the use of AC-out or DC-out. Active High, Turn ON @> 6.26 V, Turn OFF < 4.48 V. Current draw is 8-11 mA.

HIGH VOLTAGE PINOUT

Please note that improper connections may result in damage to the unit.

PIN	Signal name	Description
1	L1	Phase 1
2	L2	Phase 2
3	L3	Phase 3
4	N	Neutral
A	HVIL_IN	High voltage interlock loop input
B	HVIL_OUT	High voltage interlock loop output

Table 1 Pin configuration of AC-In

PIN	Signal name	Description
1	L1	Phase 1
2	L2	Phase 2
3	L3	Phase 3
4	N	Neutral
A	HVIL_IN	High voltage interlock loop input
B	HVIL_OUT	High voltage interlock loop output

Table 2 Pin configuration of AC-Out

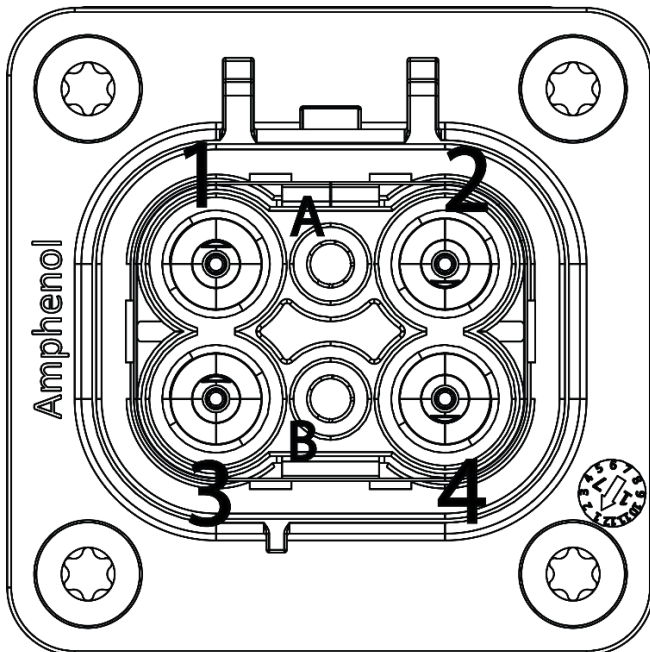

Picture 4 AC-In and AC-Out connector

PIN	Signal name	Description
1	DCOUT -	DC output negative
2	DCOUT +	DC output positive
A	HVIL_IN	High voltage interlock loop input
B	HVIL_OUT	High voltage interlock loop output

Table 3 Pin configuration of DC-Out

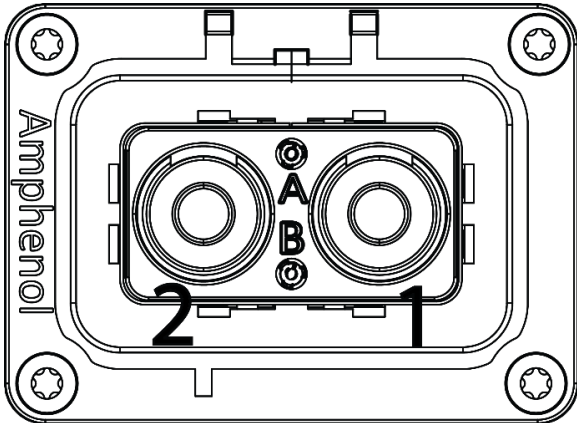

Picture 5 DC-Out connector

PIN	Signal name	Description
A	DC-	DC-link negative
B	DC+	DC-link positive

Table 4 Pin configuration of DC-link/TVB

PRODUCT CODE

Product code	Description
EC-BDC1200	Standard unit

Danfoss can accept no responsibility for possible errors in catalogues, brochures and other printed material. Danfoss reserves the right to alter its products without notice. This also applies to products already on order provided that such alterations can be made without changes being necessary in specifications already agreed. All trademarks in this material are property of the respective companies. Danfoss and the Danfoss logotype are trademarks of Danfoss A/S. All rights reserved.