

Ground Ice & Snow Melting

Application guide



Make it easy,
make it DEVI

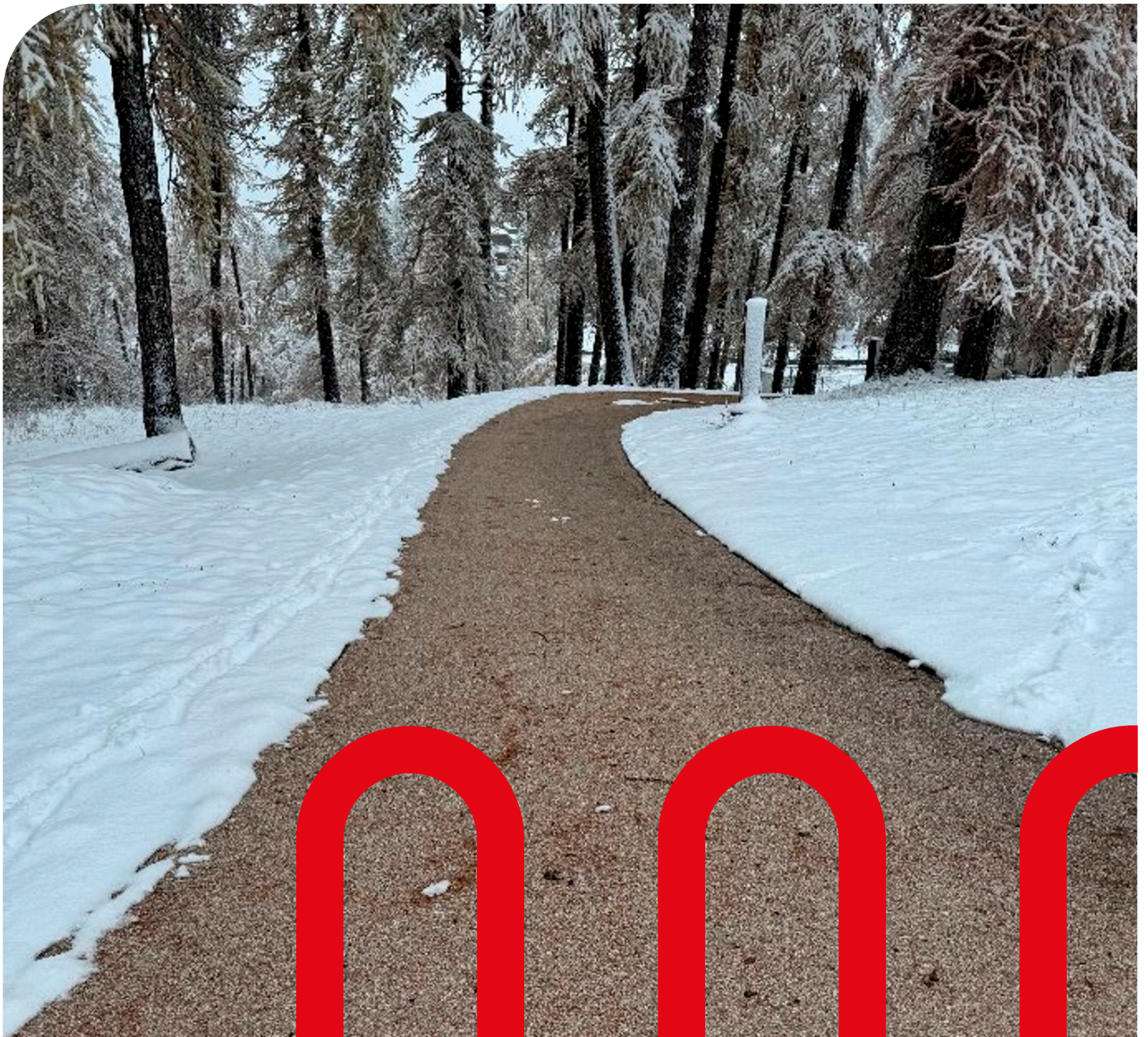

Table of contents

1. Application Overview	4
2. System description	5
3. System design	6
3.1 Heat loss calculation	6
3.2 System output	6
3.2.1 C-C distance and corresponding output (W/m ²)	7
3.3 Recommended ground constructions	9
3.3.1 Heating cable/mat embedded in concrete	9
3.3.2 Heating cable/mat with bricks/concrete tiles surface	9
3.3.3 Heating cable/mat with a thermal insulation layer	9
3.4 Design	10
4. Product selection	12
4.1 Heating elements	12
4.2 Thermostats/Controllers	13
4.3 Fixing elements	15
5. Installation process	17
5.1 Installation planning	17
5.2 Installation process	17
5.2.1 Preparing the installation area	17
5.2.2 Installing heating elements	17
5.2.3 Installation summary	18
5.3 Precautions	19
5.4 Ground sensor installation	20
6. Safety instruction	21
6.1 General safety instructions	21
6.2 DO's	22
6.3 DON'Ts	22
7. Cases	23
8. Technical support	24



Our quality management system **certifications and compliances**

✓ ISO 9001

✓ TS 16949

✓ ISO 14001

Along with full compliance with EU directives and product approvals

Let DEVI do the work

DEVI - an abbreviation of Dansk El-Varme Industri – was established in Copenhagen, Denmark, in 1942. As from January 1st 2003 DEVI has become a part of the Danfoss Group - Denmark's largest industrial Group. Danfoss is one of the world's leading companies within heating, cooling and air-conditioning. The Danfoss Group has more than 23.000 employees and serves customers in more than 100 countries.

DEVI is Europe's leading brand of electrical cable heating systems and electric pipe heating systems with over 80 years of experience. The production of heating cables takes place in France and Poland while the head office is situated in Denmark.

We have installed literally thousands of systems across the globe, in every conceivable setting. This experience means that we can offer you practical advice about precisely which components you need to get the best results at the lowest cost.

This design guide presents DEVI's recommendations for design and installation of ice and snow melting systems for ground application. It provides guidance for heating cable positioning, electrical data and system configurations.

Following DEVI's recommendations will ensure energy efficient, reliable and maintenance free solution for constant wattage heating cables with 20 year warranty.

1. Application Overview

Winter weather costs

In recent years there have been plenty of new stories about human and financial costs caused by harsh winter weather. Property damage, increased maintenance expenses, lost productivity, rising insurance premiums, personal injuries and even worse. Installation of DEVI Ice & Snow Melting System ensures a steady solution to address cold weather related problems.

DEVI's ice and snow melting system is designed to provide safety for people, vehicles, and buildings safety through safe walking and driving during winter and safety in terms of less damage to buildings.

Ground solutions – with a first class product range

By using DEVI heating cables and mats controlled by electronic thermostats with moisture sensors, you can cost-effectively protect large areas such as parking areas, ramps or pedestrian accesses to buildings giving you convenience and safety while saving a lot of tiring and time-consuming manual work.

One of the greatest advantages of these systems is the most energy efficient solution for the ground ice and snow melting applications.

Benefits

- **Efficient snow removal** - area is kept free from ice and snow at all times
- **No manual snow removal** and salting becomes unnecessary.
- **Safe traffic and working areas** for people
- **Flexible system** for most common surface covering materials
- **Cost saving** for outdoor surface repair after winter
- **Environment is protected** against salting and antifreeze related damages.
- Automatic **"Around the Clock"** snow clearing service.
- Smart 2-zone control with **low energy consumption**
- **Prioritizing** – limited power output solution
- A maintenance free system with **20 year full warranty** on cables

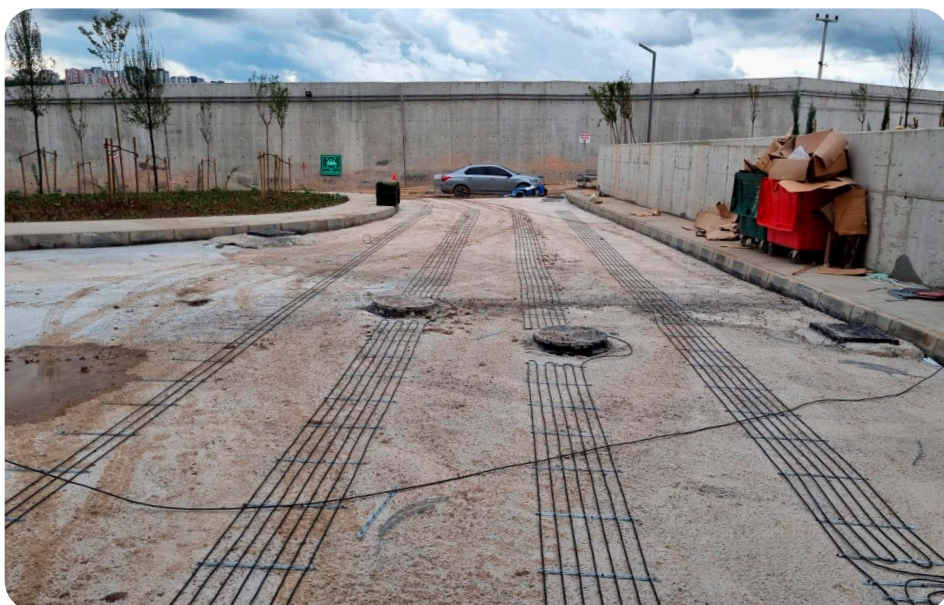

2. System description

Main purpose of the system is to melt and remove snow and ice from ground surfaces.

The most common DEVI ice and snow melting ground applications are in residential car parking areas, driveways, pavements, outdoor steps, loading platforms, ramps, bridges and drainage areas. It is even possible to melt snow and ice on mastic asphalt surfaces by using special heating cables and mats.

When heating cables are installed to melt snow or slippery ice on the ground, safety and cost saving go hand in hand.

It can be done manually or in a smart way – by means of electrical Ice & Snow Melting system with thermostat control and moisture and temperature sensors that can control 2 zones simultaneously. Inactive during cold but dry weather 2 zone control saves energy and reduces costs.

The automatic regulation of the snow melting system keeps areas free from snow and passable at all times – night and day.

When installing ice and snow melting systems on steep slopes it may be necessary to provide some drainage for melted water at the slope bottom. The drain system should also be protected against ice formations.

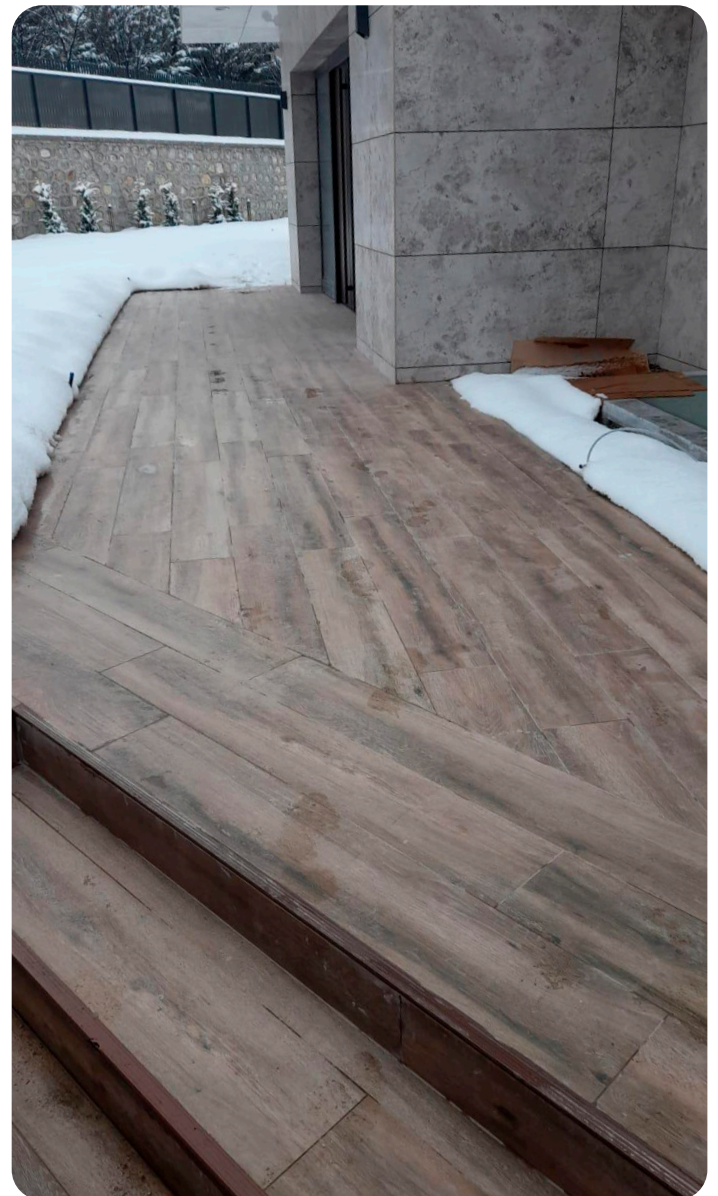

3. System design

The following paragraphs contain estimations according to ASHRAE, Application Handbook and Historical Weather Data.

Figures are for reference only

and can vary depending on the area size, wind speed and ground construction.

When installing ice and snow melting systems it may be

necessary to provide drainage for melted water at the slope bottom, walkways, etc. The drain system should also be protected against ice formations.

3.1 Heat loss calculation

The heat required for snow melting depends on the following main factors:

- Weather conditions (min. temperature, max. snowfall rate, wind speed, humidity, altitude);
- Project details (materials, foundation type, dimensions, insulation);
- Electrical data (voltage, power, control requirements);
- System performance expectations;
- Safety factor.

Evaluation of the specific output for ice and snow melting systems can be done based on the diagram and other similar documents.

For example, heat loss depending on the wind speed and temperature differences between the surface and the ambient air is described in 2003 ASHRAE Application Handbook (see fig. 1).

No back loss & area width 6 m & 50% cloud cover
Surface temp. - 3 °C & 70% relative humidity

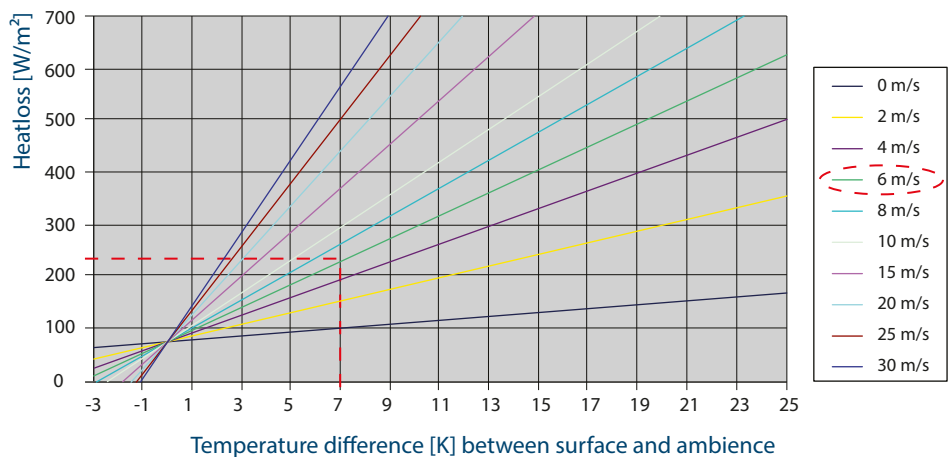

Fig. 1. Wind and temperature dependent heat loss

For example, for medium weather conditions and 6 m/s wind speed, if choosing $\Delta T = 10$ K (from -3 K to +7 K) the heat loss value is approx. 230 W/m^2 (marked with the red dotted line in fig. 1).

In other words, surface heating up to 10 degrees requires 230 W/m^2 or $230 / 10 = 23 \text{ W}/(\text{m}^2 \cdot \text{K})$.

All in all, for medium winter weather conditions, heating of 1 m^2 outdoor surface up to 1°C needs power of approx. 23 Watts. Or the calculation heat exchange coefficient for outdoor surfaces is approx. $23 \text{ W}/(\text{m}^2 \cdot \text{K})$ (sometimes named α_{out} – “alpha out”).

3.2 System output

For ice and snow melting systems it is recommended the following simple rule for output selection:

- minimum – 250 W/m^2 ,
- optimum – 350 W/m^2 .

Output for ice and snow melting systems should be designed in compliance with applicable local norms and regulations.

Add 100 W/m^2 in the following cases:

- local winter design temperature is lower than -15°C ;

- for every 1000 m altitude;
- if the heated area is free standing construction without insulation;
- if the local average wind speed is >6 m/s;
- if the more efficient system is required;
- if it snows at temperatures lower than -10 °C.

Minimum melting temperature

The main task of ice and snow melting systems is melting, i.e. to maintain +3 °C on the surface. Any output can be addressed to the lowest temperature at which ice or snow is still melting and a heating system provides its main task. Table 2 shows some heat output (W/m²) and temperature values at which the system ensures ice & snow melting or, in other words, provides constant +3 °C on the surface.

The recommended heat density values depend on the local climatic conditions and are shown in a table below.

Design temperature, °C	City, e.g.	Recommended specific output, W/m ²	Maintenable air-surface ΔT, °C
-5	London	250	11
-15	Vienna, Beijing	350	15
-25	Oslo, Kyiv	400	17
-35	Helsinki	500	21

Note. It is recommended to design output for ice and snow melting systems with maximum possible level.

Output, W/m ²	Min air temperature for +3 °C on surface ($\alpha_{out} = 23 \text{ W}/(\text{m}^2 \cdot \text{K})$)
250	-8 °C
300	-10 °C
350	-12 °C
400	-14 °C
550	-21 °C

Table 2. Minimum melting air temperatures for some outputs. ΔT surface-air is calculated as output divided by the heat exchange coefficient 23 W/(m²·K).

For example, if 250 W/m² is installed, then the heating system enables ice and snow melting at the air temperature not lower than -8 °C ($\Delta T = 250/23 \approx 11 \text{ °C}$).

But if the ambient/air temperature is -12 °C for instance, then the surface temperature will be -1 °C, with $\Delta T = -11 \text{ °C}$ for output of 250 W/m². It means that the system consumes power to heat the surface, but doesn't melt ice or snow at all.

3.2.1 C-C distance and corresponding output (W/m²)

The C-C distance is a centre-to-centre distance between adjacent cables (sometimes named "installation step").

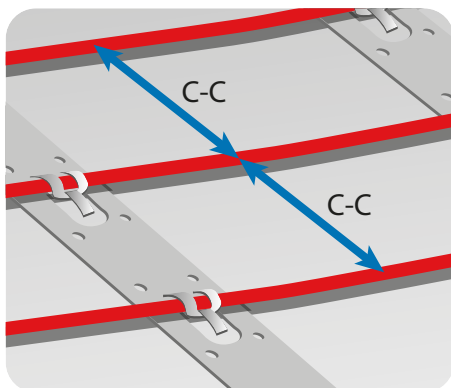

The C-C distance and corresponding output W/m² can be calculated by formulas – see Appendix.

Outputs for some cables with various C-C distances for Ice and Snow Melting Systems on the Ground are presented in the table:

C-C distance, cm	Heat density, W/m ² (230/400 V)		
	DEVIflex™ 18T 18 W/m	DEVIbasic™ 20S, DEVIsafe™ 20T 20 W/m	DEVIsnow™ 30T, DEVIsphalt™ 30T 30 W/m
5	360	400	600
7,5	240	270	400
10	-	-	300
12,5	-	-	240

Note! Heating cable bending diameter must be at least 6 times cable diameter.

When heating cables are installed, we recommend the use of DEVIfast™ fitting bands. These bands are designed to ensure a C-C distance at regular intervals of 2,5 cm, e.g. 5 cm, 7,5 cm, 10 cm, 12,5 cm, etc.

Two different formulas may be used to calculate the C-C distance:

1) Using heating cable length

$$C - C \text{ [cm]} = \frac{\text{Heated floor space [m}^2\text{]} \cdot 100 \text{ [cm/m]}}{\text{Cable length [m]}}$$

2) Using cable specific output and output per m²:

$$C - C \text{ [cm]} = \frac{\text{Cable specific output [W/m]} \cdot 100 \text{ [cm/m]}}{\text{Output per m}^2 \text{ heated floor space [W/m}^2\text{]}}$$

Example 1

For a renovation we choose a DEVIflex™ 10T cable (specific output is 10 W/m). If the chosen output is 120 W/m², the calculated by formula no. 2 C-C distance is:

$$C - C = \frac{10 \text{ W/m} \cdot 100 \text{ cm/m}}{120 \text{ W/m}^2} = 8,33 \text{ cm.}$$

Example 2

The DEVIflex™ 18T, 535 W, 29 m is to be installed in a bathroom with heated floor space of 3 m².

The calculated by formula no. 1 C-C distance is:

$$C - C = \frac{3 \text{ m}^2 \cdot 100 \text{ cm/m}}{29 \text{ m}} = 10,35 \text{ cm.}$$

If we use DEVIfast™ fitting bands with regular intervals of 2,5 cm, we can install the heating cable in this bathroom with a C-C 10 cm.



3.3 Recommended ground constructions

3.3.1 Heating cable/mat embedded in concrete

Heating cable/mat placed on concrete or sand/grit basement.

- It is recommended to place the cable min at 5 cm depth from the surface if installed in concrete. Concrete thickness has to be chosen according to the local norms and regulations.
- Make sure that the mat/cable is fastened to the basement as concrete might cause displacement of the cable when poured.

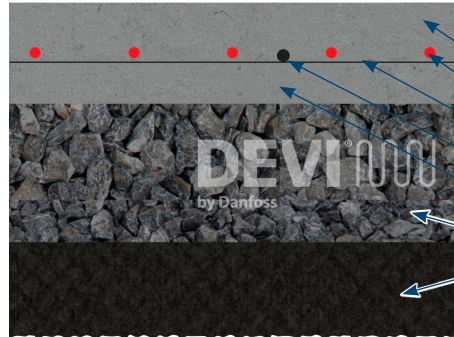

- The concrete mixture must not contain sharp stones which may damage the cable.
- Concrete needs 30 days to harden before operation of the heating cables.

3.3.2 Heating cable/mat with bricks/concrete tiles surface

Heating cable/mat placed into sand or sand mixture.

- Special care must be taken to avoid damage of the heating cable when installed under bricks/tiles.
- The area must be completely levelled and free of stones or other sharp objects.
- The heating cable/mat must be installed closely to the bricks/tiles, typically in a sand layer (at least 2,5 cm under the brick/tile).

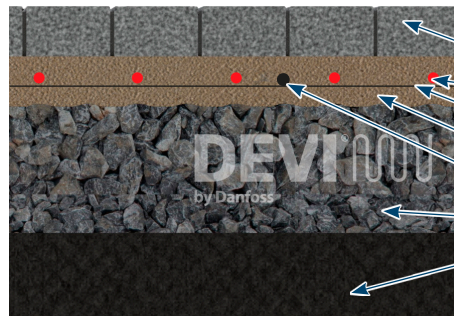

layer (at least 2,5 cm under the brick/tile).

3.3.3 Heating cable/mat with a thermal insulation layer

Heating cable/mat placed on a thermal insulation into concrete protection layer.

- It is strictly prohibited to install heating cable/mat directly on a thermal insulating material.
- When a thermal insulation layer is applied the concrete protection layer should be provided.
- When laying a heating cable, special care must be taken to avoid its penetration of the thermal insulating material.

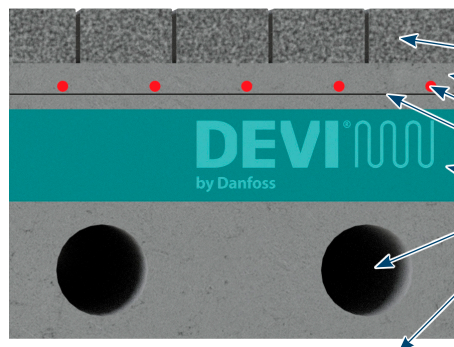

avoid its penetration of the thermal insulating material.

3.4 Design

The system is usually designed taking the available power supply into account. If the available power supply is limited, then:

- Reduce the area to be heated, e.g. by heating tire tracks instead of the whole driveway.
- Divide and prioritize the area in 2 zones by means of DEVIreg™ 850 or e.g. 2 DEVIreg™ 330 (5...45 °C).
- Install minimum recommended W/m^2 , knowing that the snow melting performance is reduced.
- Do not install less W/m^2 than recommended in areas of drainage e.g. in front of heated steps.
- **For sloped roads, bridges, ramps, and other critical road sections, heating cables shall be installed parallel to the direction of traffic flow in order to minimize the risk of traffic accidents in the event of failure of one of the heating cables.**

If the snow melting system is undersized, e.g. due to power limitations, the system will respond slower and less efficiently. A higher temperature level compensates this, but causes higher running costs.

If the snow melting system is oversized, the system will respond faster and more efficiently. To lower the standby temperature and running costs, DEVIreg™ 850 can be used.

Example 1. Walkway with pavement blocks

An ice and snow melting system is required to melt snow from a

2 x 10 m walkway with pavement blocks on sand. Power supply voltage is 400 V. Heating mats can be selected due to their simple installation.

Heating mats output is $300 W/m^2$ (near optimum output level – see 4.1).

Total output:
 $300 W/m^2 \cdot (2 m \cdot 10 m) = 6000 W$.

Two mats DEVIsnow™ 300T 400 V (1 m width) can be chosen:
 $4250 W (1 m \times 14,8 m) + 1770 W (1 m \times 6 m) = 6020 W (20,8 m^2)$.

Optionally, heating cable DEVIsnow™ 30T 400 V with C-C = 10 cm ($300 W/m^2$) can be chosen: either $5770 W (190 m, 19 m^2)$ or $6470 W (215 m, 21,5 m^2)$.

When thermostat DEVIreg™ 330 (5...45 °C) with a sensor cable placed in the ground is chosen, DEVIreg™ 850 with two ground sensors can be selected as an option.

Example 2. Driveway near garage of a private house

Data: driveway dimensions – 10 m length, 2 m width; surface thickness – 6 cm; power supply – 230 V; restriction of power for electricity connection.

Due to restriction of power supply it should be recommended installation of a heating cable in two tire tracks instead of the whole driveway. Width of tire track is 0,5 m.

1. **Cable selection.** For this system it can be used for instance a two-conductor DEVIflex™ 18T (see chapter 3). To comply with the recommended in 4.1 output of $350 W/m^2$ it should be chosen C-C = 5 cm that gives specific output of $360 W/m^2$.
2. **Calculation of the cable installation area:**
 $10 m \cdot 0,5 m \cdot 2 \text{ track} = 10 m^2$.
3. **Calculation of the total system power:**
 $10 m^2 \cdot 360 W/m^2 = 3600 W$.
4. **Selection of cable power/length.** Cable DEVIflex™ 18T with 3600 W output does not exist (see DEVI Catalogue), so you should apply two cables with total capacity of about 3600 W, i.e. cables with the output: $3600 / 2 = 1800 W$. This output can be ensured by for instance DEVIflex™ 18T – 90 m, 1625 W, 2 pcs. The total output of two cables will be 3250 W that is a bit less than the calculated

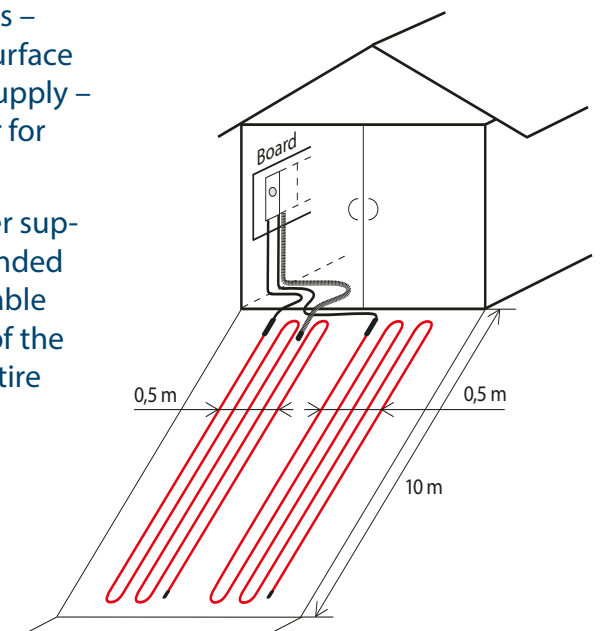

value, and for C-C = 5 cm the heating area is approx. 9 m². Alternatively you can select two DEVIflex™ 18T – 105 m, 1880 W with total output – 3760 W.

Note. If the driveway near the garage has a tray for water drainage, it is necessary to install at least two lines of cable along the drainage and its length should be taken into account when choosing the cable.

5. Length of fixing tape. The cable can be attached by e.g. DEVIfast™. Installation step is typically 50 cm and the length

is defined as the heating area multiplied by 2 that is $10 \text{ m}^2 \cdot 2 = 20 \text{ m}$ of DEVIfast™.

6. Thermostat selection. Since the system output is small – less than recommended 10 kW, you can choose “simple” DEVIreg™ 330 (5... 45 °C) with a wire temperature sensor, which is installed in the ground. An appropriate connection scheme should be chosen – with or without contactor. The output of two 90 m cables is 3250 W that enables their connection to one DEVIreg™ 330 of

max 3680 W, therefore an additional contactor is not required. The output of two 105 m cables is 3760 W that disables their connection to one DEVIreg™ 330, therefore an additional contactor is required.

7. Calculation of thermostat temperature settings (see 4.3). The installation depth of a wire temperature sensor is 6 cm and in order to maintain the surface temperature of +3 °C the following value should be set:
 $1,5 \text{ °C/cm} \cdot 6 \text{ cm} + 3 \text{ °C} = 12 \text{ °C}$.



4. Product selection

4.1 Heating elements

Electrical heating system consists of two major components:

- Heating element – heating cable or heating mat;
- Thermostat with a temperature sensor or regulator/controller with temperature and moisture sensor(s).

Heating cables and mats for Ground applications are usually installed into concrete construction or into special glue under tiles.

DEVI heating cables and mats for Ground applications are designed for installation in concrete constructions or into special glue under tiles. Usual thickness of top/finish concrete layer for outdoor applications is at least 5 cm. But the thickness should comply with a ground construction and local norms and regulations.

Heating cables used in ground constructions are serial resistive cables, single or twin conductor. Most of cables and mats are manufactured as ready-to-install heating elements with connecting power supply cable (cold lead or cold tail) and sealed joints (muffs or end terminals).

Range of heating cables linear output for ground application is usually 15-30 W/m. DEVI ready-made cables are available with 18, 20, 30 W/m output (for 230 and 400 V).

Heating mats are available with 300 W/m² output.

Most DEVI cables are manufactured and approved in accordance with the latest revision of IEC 60800:2009, with M2 mechanical strength class (for rough concrete constructions).

The main type of DEVI heating cables is twin conductor heating cables. Internal design of a modern twin conductor DEVIflex™ cable are shown in the figure below.

Heating elements

For Ground Ice and Snow Melting systems the following resistive (constant wattage) heating elements can be used.

Heating cables:

- Twin conductor DEVIsnow™ 20T and DEVIsnow™ 30T (230/400 V);
- Twin conductor DEVIsnow™ on drum (max 400 V);
- Twin conductor DEVIsafe™ 20T (230 V);
- Twin conductor DEVIflex™ 18T;
- Single conductor DEVIbasic™ 20S (230/400 V);

- Single conductor DEVIbasic™ on drum (max. 400 V).

Heating mats:

- Twin conductor DEVIsnow™ 300T (230/400 V).

Note. The number at the end of the cable's and mat's name refers to its linear output – W/m or area output – W/m², at 230 V or 400 V. Letter "T" means twin conductor cable/mat (Twin), letter "S" – single-conductor cable/mat (Single).

DEVI resistive heating cables ensure safe, efficient and economical ground application.

To ensure long life-time and quality all cables are thoroughly inspected including tests for ohmic resistance, high voltage and material control.



DEVIsnow heating cable

Item no.	Product name	Description
Resistive heating mat DEVIsnow™ 300T	DEVIsnow™ 300T, 230 & 400 V program	Twin conductor, 100% screen, FEP conductor insulation, UV stable, black. 300 W/m ² (230/400 V).
Resistive heating cable DEVIsnow™	DEVIsnow™ 20T, 230 & 400 V program; DEVIsnow™ 30T, 230 & 400 V program	Twin conductor, 100% screen, FEP conductor insulation, UV stable, black. 20 and 30 W/m (230/400 V). DIN IEC 60800:2009 M2
Resistive heating cable DEVIsnow™	DEVIsnow™ on drum, 0,055-9,36 Ohm/m	Twin conductor, 100% screen, FEP conductor insulation, UV stable, black. Max. 30 W/m, max. 400 V. DIN IEC 60800:2009 M2
Resistive heating cable DEVIsafe™ 20T	DEVIsafe™ 20T, 230 V program	Twin conductor, 100% screen, UV stable, black. 20 W/m (230 V). DIN IEC 60800:2009 M2
Resistive heating cable DEVIflex™	DEVIflex™ 18T, 230 V;	Twin conductor, 100% screen, red. 18 W/m (230 V). DIN IEC 60800:2009 M2
Resistive heating cable DEVlbasic™ 20S	DEVlbasic™ 20S, 230 & 400 V program	Single conductor, wire screen, red. 20 W/m (230/400 V). DIN IEC 60800:1992 C
Resistive heating cable DEVlbasic™	DEVlbasic™ on drum; 0,0134-34,1 Ohm/m	Single conductor, wire screen, red. Max. 20 W/m; max. 400 V. DIN IEC 60800:1992 C

For additional information please refer to the DEVI Catalogue.

4.2 Thermostats/Controllers

Ice and snow melting systems are different and require different thermostats/regulators.

DEVlreg™ thermostats and regulators are fitted with a complete set of control functions for heating systems for ice and snow melting of any type and allow attaching external sensors for measuring ground temperature as well as control of moisture conditions.

The product range of controls is designed for ground outdoor systems including the following:

- thermostats with a temperature sensor – DEVlreg™ 330 (5...45 °C), DEVlreg™ 610, DEVlreg Multi;
- regulator with an integrated temperature and moisture sensor(s) – DEVlreg™ 850.

To control simple or low output systems a thermostat with a ground temperature sensor is recommended. **DEVlreg™ 330 (5...45 °C)** thermostat with the

DIN rail attachment is recommended as a standard solution. Also can be used **DEVlreg™ 610**, IP44 with on wall/pipe mounting.

DEVlreg™ Multi is 7 channel electronic programmable controller to be installed on DIN rail.

All thermostats above are supplied with a wire temperature sensor – NTC 15 kOhm @25 °C, 3 m.

To control ice and snow melting systems especially with high output the best solution is **DEVlreg™ 850** regulator/controller with integrated ground and roof moisture and temperature sensors.

DEVlreg™ 850 is a two-zone controller with possibility of connection up to 4 sensors to provide maximum control of the outdoor heating system. Comparing to installations with typical ground temperature measuring this regulator ensures reducing energy consumption costs by up to 40%.



DEVlreg™ 850 with ground sensor



DEVlreg™ Multi



DEVlreg™ 610



DEVlreg™ 330 (5...45 °C)
with wire sensor in set

Zone support saves energy

The DEVIreg™ 850 lets you divide your area in to 2 zones, e.g. a North and South side. In this way it is possible to save energy, when the South side is free of ice and snow faster because of the heat from the sun.

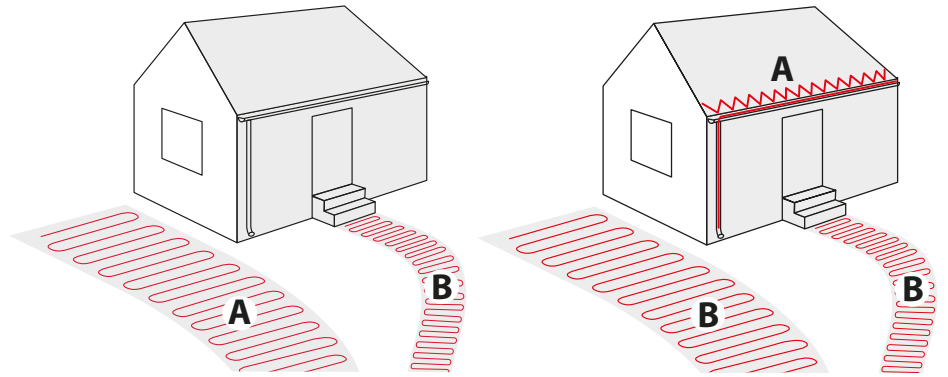

Prioritizing – for limited power output

You can prioritize between the zones, e.g. if you have limited power output. This way one zone is made ice and snow free before focus is put on the other zone.

Item no.	Product name	Description
Regulator DEVIreg™	DEVIreg™ 850	Connection to Ground and Roof moisture and temp. sensor, max 4 sensors, 2 zones, 2x15 A, PSU 24 V, DIN rail
Moisture & temperature sensor	Ground sensor for DEVIreg™ 850	Ø93 x 98 mm, IP67, 15 m connection cable 4x1 mm ²
Accessories	PSU 24 V for DEVIreg™ 850	Extra PSU for DEVIreg™ 850 with 3-4 sensors
Thermostat DEVIreg™	DEVIreg™ Multi	-50...+250C, 7 channel (2 x 10A, 5 x 6A), IP40, with 3 m wire sensor, DIN rail
Thermostat DEVIreg™	DEVIreg™ 610	-30...+50 °C, 10 A, IP44, with 3 m wire sensor, on wall/pipe installation
Thermostat DEVIreg™	DEVIreg™ 330 (5...45 °C)	5...45 °C, 16 A, IP20, with 3 m wire sensor, DIN rail
Temperature sensor	10 m, PVC	Wire sensor, Ø8 mm, IP65, NTC 15 kOhm @25 °C

For additional information please refer to the DEVI Catalogue.

Control solution choice

Ice and snow melting systems are different and require different thermostat types. The product range of controls is designed for ground outdoor systems including the following:

- thermostats with a temperature sensor – DEVIreg™ 330 (5...45 °C), DEVIreg™ 610, DEVIreg Multi;
- regulator with integrated temperature and moisture sensors – DEVIreg™ 850.

To control simple or low output systems – approx. up

to 5 kW – thermostat with a wire temperature sensor is recommended.

To control systems with up to 10 kW output a regulator/controller with temperature and moisture sensors is recommended. This solution should be used for any smaller installations where optimum power is a priority.

The wire temperature sensor is usually installed in a conduit pipe nearby the heating cable (“in the ground”). DEVIreg™ 330 (5...45 °C) thermostat with the DIN rail

attachment is recommended as a standard solution. It can be also used a wall/pipe mounted DEVIreg™ 610, IP44.

To control ice and snow melting systems DEVIreg™ 850 regulator/controller with an integrated temperature and moisture sensor is recommended at the optimum power. We recommend this regulator for installations with output exceeding 10 kW or for any smaller installations where optimum power is a priority.

The ground sensor is equipped with a 15 m cable for connection to a regulator. The cable length

can be adjusted in accordance with the Installation Instruction.

Comparing to installations with typical ground temperature measuring this regulator allows reducing energy consumption costs of up to 40%.

Temperature adjustment.

The temperature sensor is mounted below the surface near the heating cable, where it is "warmer" than on the surface. This enables system adjustment to the desired temperature: for each 1 cm below the surface it should be adjusted to about +1,5 °C or approx. 1,5 °C/cm.

For example, if the sensor is installed under the pavement of 10 cm thickness, temperature adjustment should be: 1,5 °C/cm · 10 cm = 15 °C. Taking into account the required +3 °C at the surface, the thermostat should be set to 15 °C + 3 °C = 18 °C. Therefore, the use of DEVIreg™ 330 with temperature range -10... +10 °C is not recommended since it is impossible to set temperature over +10 °C.

Running costs

The running costs are largely influenced by how the system is controlled. DEVIreg™ 850 is a more efficient solution since a moisture sensor enables its switching to a standby mode during dry periods.

Thermostat	Sensor type	Running cost index
DEVIreg™ 850	Ground temperature and moisture	1
DEVIreg™ 330	Ground temperature (e.g. +3 °C)	1,2 - 1,4
Reference	Air temperature	2 - 5

4.3 Fixing elements

In case of heating cables application, it is recommended to use fitting bands to fix the cable to the base, e.g. DEVIfast™ metal galvanized fitting band (see see 4.3.1). It should be attached to the ground (e.g. nailed down) in parallel lines usually at intervals of 50 cm or using 2 meters of

fitting band per each square meter of cable installation. The same applies to DEVIclip™ C-C and Montagestege™ plastic bands.

For quick cable fixing to reinforced mesh DEVIclip™ Twist plastic fixing is recommended.



Montagestege™



DEVIfast™

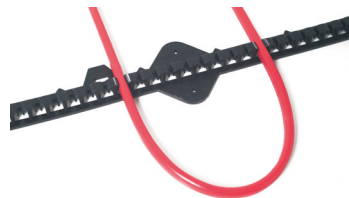

DEVIclip™ C-C



DEVIclip™ Twist

Item no.	Product name	Description
Fixing	DEVIfast™ Metal DEVIclip™ C-C Montagestege™ 6 mm Montagestege™ 8 mm	25 m pack; galvanized metal, fixings every 2,5 cm. 10 x 1 m; plastic, fixes cable Ø every 1 cm. 1 m; plastic, fixes cable Ø 5,6-6,5 mm every 2,5 cm. 1 m; plastic, fixes cable Ø 6,6-8 mm every 2,5 cm
Fixing	DEVIclip™ Twist	Bag with 1000 pcs.; Ø 17 mm; fixing cable to reinforced mesh

For additional information please refer to the DEVI Catalogue.

If we want to calculate the length of fitting band (e.g. DEVIfast™, DEVClip™ CC, Montagestege™), first of all we should determine the distance between the fitting bands.

For concrete installation, where cable is covered with 3 cm concrete or more, and the C-C distance exceeds 10 cm, the

recommended distance between fitting bands is 0,5 m.

For thin constructions where cable is covered with 1-2 cm of self-leveling compound and the C-C distance is 10 cm or less, the max. recommended distance between fitting bands is 25 cm.

Below is a calculation formula for C-C distance.

$$\text{Length of fitting band [m]} = \frac{\text{Heated floor space [m}^2\text{]}}{\text{Distance between fitting bands [m]}} + L_w \text{ [m]}$$

L_w is the length of the wall parallel to fitting bands installation.

Example

The heated floor space is 1 m x 2 m = 2 m².

If we install DEVIfast™ fitting bands in parallel to a 1 m wall (see fig. 1) and the distance between the DEVIfast™ fitting bands is 0,5 m, a fitting band with the following length is required:

$$\frac{2 \text{ m}^2}{0,5 \text{ m}} + 1 \text{ m} = 5 \text{ m.}$$

If we install DEVIfast™ fitting bands in parallel to a 2 m wall (see fig. 2) and the distance between the DEVIfast™ fitting bands is 0,5 m, a fitting band of the following length is needed:

$$\frac{2 \text{ m}^2}{0,5 \text{ m}} + 2 \text{ m} = 6 \text{ m.}$$

As we can see from this example, the fitting band length may vary although the area and the distance between fitting bands remain the same.

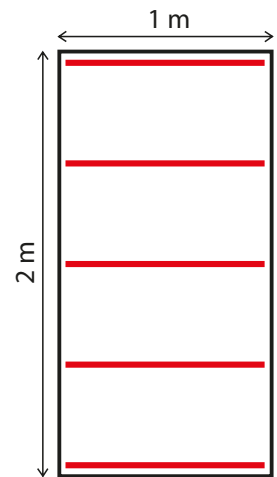

Fig. 1 - Fitting band installed in parallel to a 1 m wall.

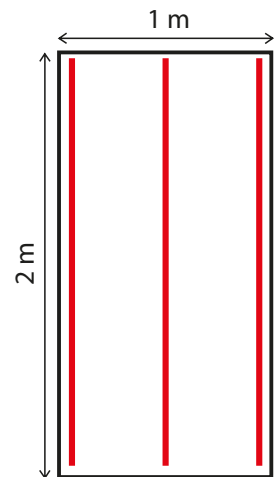
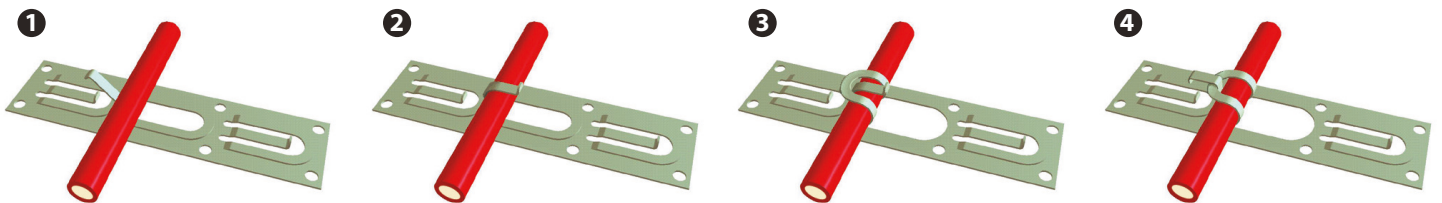

Fig. 2 - Fitting band installed in parallel to a 2 m wall.



Fixing of the heating cable on the DEVIfast™ fitting band.

5. Installation process

5.1 Installation planning

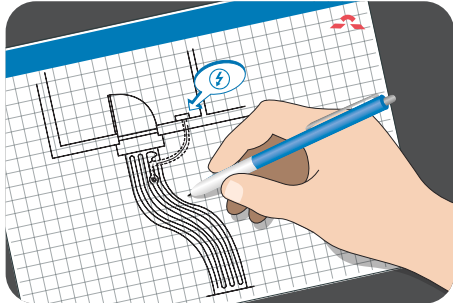

Draw a sketch of the installation showing

- element layout
- cold leads and connections
- junction box/cable well (if applicable)

- sensor
- connection box
- thermostat/regulator

Save the sketch

- Knowing the exact location of these components makes subsequent troubleshooting and repair of faulty elements easier.

Please observe the following:

- Observe all safety guidelines.
- Observe correct cable

C-C distance and distance between mats.

- Observe required installation depth and possible mechanical protection of cold leads according to local regulations.
- When installing more than one heating element, never wire elements in series but route all cold leads in parallel to the connection box.
- For single conductor cables, both cold leads must be connected to the connection box.

5.2 Installation process

5.2.1 Preparing the installation area



Remove all traces of old installations, if applicable.

- Ensure that the installation surface is even, stable, smooth, dry and clean.

- If necessary, fill out gaps around pipes, drains and walls.
- There must be no sharp edges, dirt or foreign objects.

5.2.2 Installing heating elements

It is not recommended to install heating elements at temperatures below -5°C .

At low temperatures, heating cables can become rigid. Connect the cable/mat to the mains for a short time (few minutes). The cable or mat must be rolled out during this process!

Measuring resistance

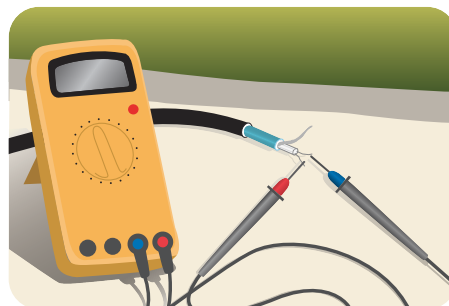

Measure, verify and record element resistance during installation.

- After unpacking.
- After fastening the elements.
- After the installation is finalized.

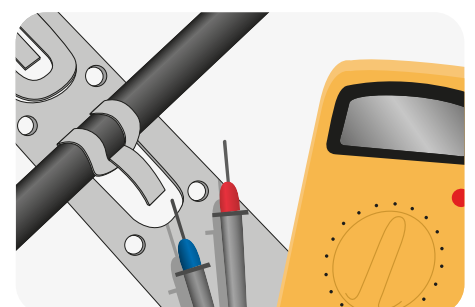

If Ohm resistance and insulation resistance are not as on label attached to product and product transportation box, the element must be replaced.

- The ohmic resistance must be within -5 to +10 % of the value labeled.
- The insulation resistance should read >20 MΩ after one minute at min. 500 V DC.

Observe all instructions and guidelines in section about general safety and in proper installation instructions.

Heating elements

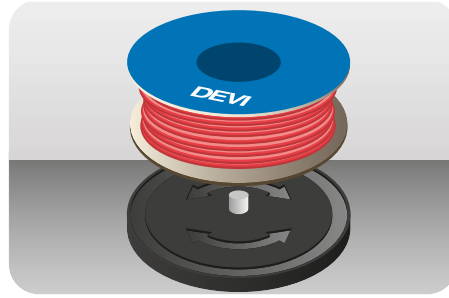

- Position the heating element so that it is at least half the C-C distance from obstacles.
- Heating elements must always be in good contact with the heat distributor (e.g. concrete).
- When using heating mats secure them to the ground, some mats are mitted with a glue covered surface, it

attaches well to a cleaned and primed surface.

Heating mats

- Always roll out heating mats with the heating cables facing up.
- When the heating mat reaches the area boundary, cut the liner/net and turn the mat before rolling it back.

Extending cold leads

- Avoid extending cold leads if possible. Wire cold leads to e.g. junction boxes or cable wells.
- Be aware of power loss in the extending cold leads according to local regulations and wiring rules.

5.2.3 Installation summary

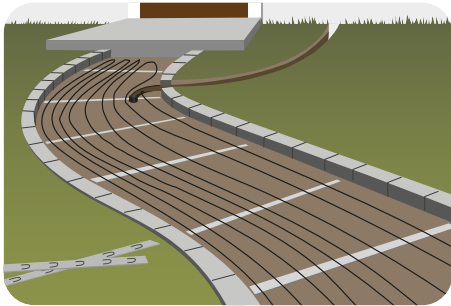

Prepare installation surface with fastening accessories and/or mesh reinforcement.

Apply sensor conduit Ø 16-20 mm. Fix conduit for sensor tube for DEVIreg™ 850 ground sensor, if any.



Place cold leads and connections in a dry place. Seal all penetrations through walls or similar structures. Apply caution tape above cold leads.

After laying blocks or pouring concrete/asphalt, install external sensor(s), and extend sensor cable(s) according to the sensor manual.

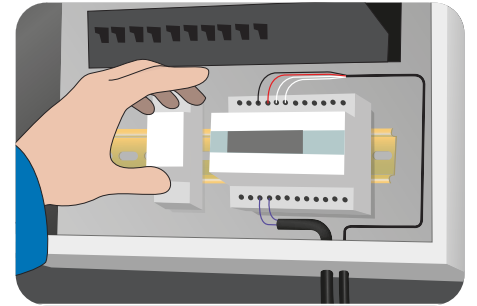

The DEVIreg™ thermostat/regulator must be commissioned as prescribed in the installation manual and adjusted where local conditions vary in relation to factory settings.

Before every season, check for faults in the switchboard, thermostat and sensors.

5.3 Precautions

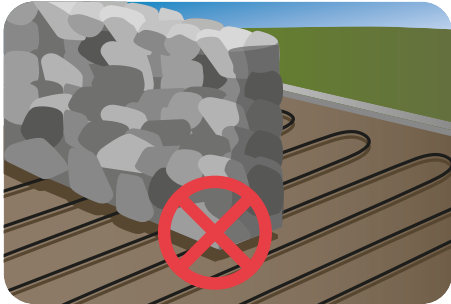

Do not install heating elements under walls and fixed obstacles. Min. 6 cm space is required. Keep elements clear of insulation material, other heating sources and expansion joints.



Heating elements may not touch or cross themselves or other heating elements and must be evenly distributed on areas.



The elements and especially the connection must be protected from stress and strain.



The element should be temperature controlled and not operate at ambient temperature higher than 10 °C in outdoor applications.



Ensure to clean the area properly from stone and sharp edges.



Protect the heating cables against excessive use of rakes, shovels, vibrators and rollers.

Fasten the cables to the sub-construction in short distances to ensure that the cable remains in right position.

It is recommended to connect a buzzer or other alarm giving device to the cables if an incident anyway should occur during installation despite all caution and a cable is being damaged. Then there will be the ability to quickly detect this and get the problem solved at the lowest possible cost and delay.

Ensure that all cables turn towards the electrical cupboards where the cables shall be connected.



Remember that the cable always shall be fully embedded to avoid air gaps.



It is not allowed to drive directly on the cables with heavy trucks or asphalt machinery. It will immediately lead to cable damages.

5.4 Ground sensor installation

Installing ground sensors

At this point you must have located the appropriate spots for the ground sensors and extended the feeder cable if necessary.

The sensor part and the sensor tube may now be installed in connection with the actual construction work and connected at a later date. The following applies for all types of installations.

- The base below the sensor tube must be hard, e.g. a concrete plate or similar, in order to ensure that the sensor is not pushed into the ground if e.g. a lorry runs over it. The tube is designed to be mounted on a plate using the two screw holes inside the tube.
- Place the sensor tube in between the heating cables with a minimum distance of 1 cm.
- The sensor tube must be positioned so that it is flush with the surrounding terrain

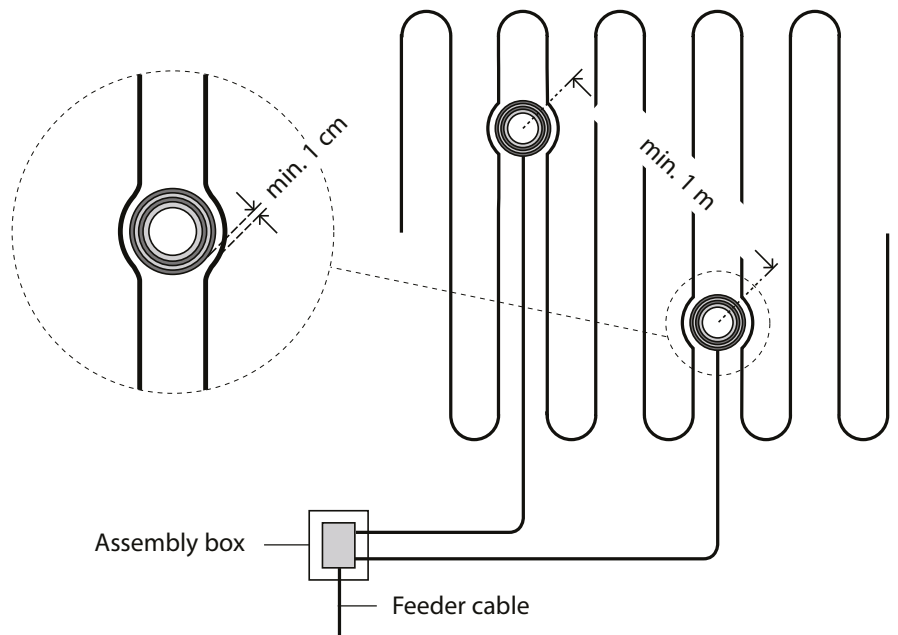

and so that the sensor part must be placed so that the upper brass surface is horizontal.

- Lay a conduit for the sensor cable between the sensor tube and the Devireg 850 controller.

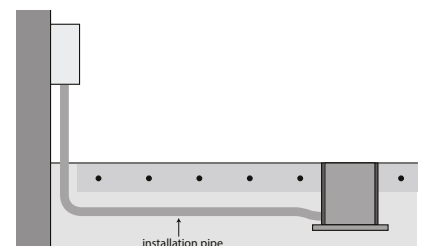
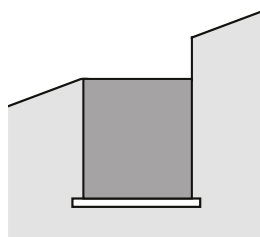

6. Safety instruction

6.1 General safety instructions

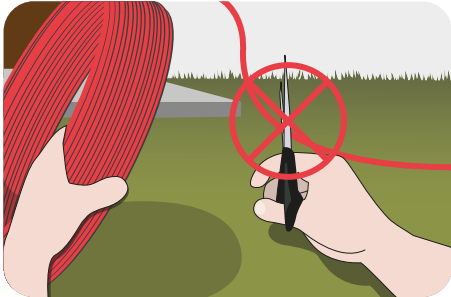

Never cut or shorten the heating element.

- Cutting the heating element will void the warranty.
- Cold leads can be shortened to suit requirements.

Elements must always be installed according to local building regulations and wiring rules as well as the guidelines in proper installation instructions and this manual.

- Any other installation may hamper element functionality or constitute a safety risk, and will void the warranty.
- Make sure that elements, cold leads, connection boxes, and other electrical components do not come into contact with chemicals or flammable materials during or after installation.

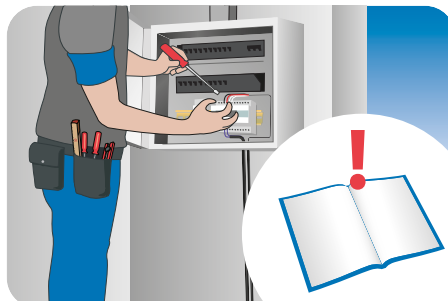

Elements must always be connected by an authorized electrician using a fixed connection.

- De-energize all power circuits before installation and service.
- The connection to the power source must not be directly accessible to the end user.
- Each heating cable screen must be earthed in accordance with local electricity regulations and connected to a residual current device (RCD).
- Recommended RCD trip rating is 30 mA, but may be up to 300 mA where capacitive leakage may lead to nuisance tripping.
- Heating elements must be connected via a switch providing all pole disconnection.

- The element must be equipped with a correctly sized fuse or circuit breaker, e.g. 10/13 A for a 1,5 mm² cold lead and 16/20 A for a 2,5 mm² cold lead.

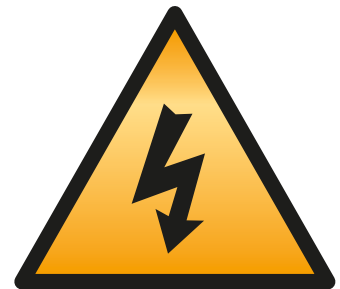

The presence of a heating element must

- be made evident by affixing caution signs or markings at the power connection fittings and/or frequently along the circuit line where clearly visible
- be stated in any electrical documentation following the installation.

Never exceed the maximum heat density (W/m² or W/m) for the actual application.

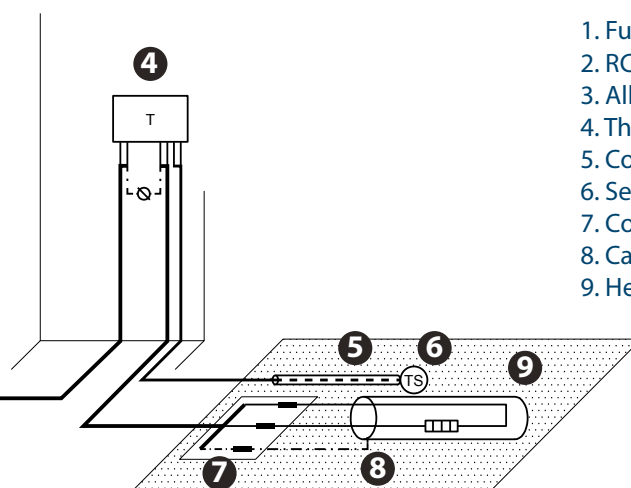
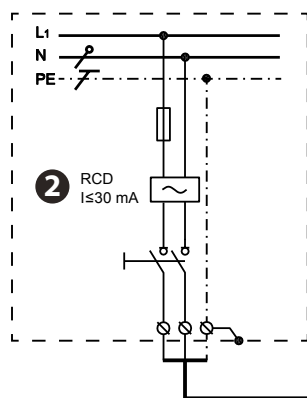

1. Fuse
2. RCD
3. All-pole switch
4. Thermostat
5. Conduit pipe
6. Sensor
7. Connection muff
8. Cable screen
9. Heating cable

6.2 DO's

- For installation of cable and thermostat/controller, always refer to the local regulations/ legislations and respective manuals;
- Remember to fill out the warranty certificate with the required information as this will not be valid otherwise;
- Carefully complete the installation, the cable can break when overloaded;
- If any doubt arises consult you manual or local DEVI department;
- Ensure that the cable is sufficiently fixed and mounted according to the manual;
- Ensure that warning labels and stickers (potentially tape) with warning text is used to inform about the heat traced cable;
- Install sensors where the temperature is estimated to be representative for the whole installation, where 2 sensors are needed for the thermostat/ controller please install at the estimated extreme points (coldest and hottest);
- To get the best performance of the system and avoid failures it is necessary to follow the installation descriptions;
- To get the best performance of the system it is strictly necessary to calculate the correct heat losses. Using this knowledge the cable with right output can be chosen;
- Plan every installation step and fixing point of the frost protection system ahead of time and ensure that the "run" is proper and possible;
- Ensure sensors are connected according to the applicable installation guide and/or application guide.

6.3 DON'Ts

- Heating elements may not touch or cross themselves or other heating elements and must be evenly distributed on areas.
- **Never cut or shorten the heating element.**
- Do not wind excess cable onto itself at the end of a run, as this can cause overheating and may damage the cable. Instead, distribute the excess cable evenly within the adjacent area (secondary loop/section).
- Never make an installation without thermostat/controller;
- Never install cables where the heat can't be dissipated, even with a self-limiting cable the output will never become zero and the cable can overheat;
- Never let unauthorized personnel install controllers/ thermostats or heating elements;
- Never use unauthorized accessories;
- Never use our products (cables, controllers, sensors, etc.) outside provided temperature range.

7. Cases

Rozadol Bratislava Bratislava, Slovakia

Purpose of the DEVI system:
Ice and snow melting on
driveway in underground garage.

Project size:
400 m².

Products:

- DEVIflex™ 18T;
- DEVIreg™ 850.



Cineplexx (cinema), Hohenems, Austria.

Purpose of the DEVI system:
Outdoor heating of the stairs to
the entrance.

Project size:
89 m² area heated with 86 pcs.
mats.

Products:

- DEVIsnow™ 300T, 400 V;
- DEVIreg™ 850 + Ground sensor.



8. Technical support

The Electric Heating team supports professionals with reliable expertise and proven solutions.

We offer:

- Precise calculation and design of electric heating systems
- Development of project drawings
- Preparation of a complete Bill of Materials (BoM)
- Practical recommendations for installation and system operation
- Professional technical training

With our experience, you can be confident in efficient, safe, and long-lasting electric heating solutions.

In order to clarify the project data for different applications use the following technical request forms, fill in with your specifications and send it to:

EH@danfoss.com



<https://devi.com/en/service-and-support/global-technical-support>



Make it easy,
make it DEVI



Follow our global channels



140F9006 & AB212486469821en-010203 | 15.04.2026



Make it easy,
make it DEVI

Danfoss A/S

DEVI • devl.com • +45 7488 2222 • EH@danfoss.com

Any information, including, but not limited to information on selection of product, its application or use, product design, weight, dimensions, capacity or any other technical data in product manuals, catalogues descriptions, advertisements, etc. and whether made available in writing, orally, electronically, online or via download, shall be considered informative, and is only binding if and to the extent, explicit reference is made in a quotation or order confirmation. Danfoss cannot accept any responsibility for possible errors in catalogues, brochures, videos and other material. Danfoss reserves the right to alter its products without notice. This also applies to products ordered but not delivered provided that such alterations can be made without changes to form, fit or function of the product.

All trademarks in this material are property of Danfoss A/S or Danfoss group companies. Danfoss and the Danfoss logo are trademarks of Danfoss A/S. All rights reserved.

devl.com