

Let's level up liquid cooling

Our solutions and expertise for your CDUs

At the heart of modern liquid-cooled data centers sit Coolant Distribution Units (CDUs)—and a substantial potential for optimization in efficiency, control, footprint and integration.

With Danfoss, you get modular solutions and co-development opportunities for almost the entire CDU ecosystem. We are not selling parts. We help you build better CDUs. Let's level up liquid cooling, together.

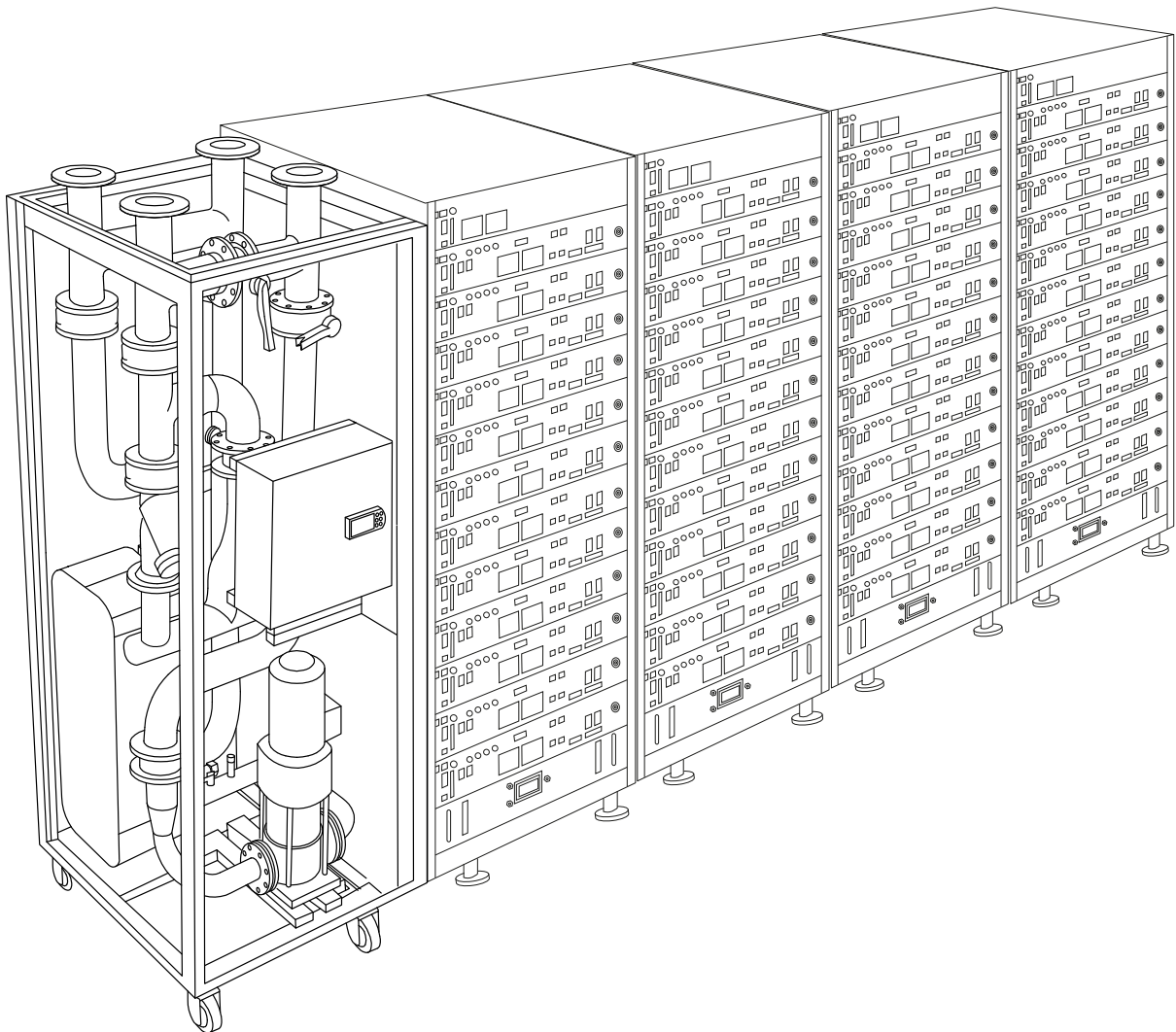

Welcome to your curated CDU hardware store

From heat exchangers over valves, drives, and sensors to controllers – with Danfoss, you get almost every component to build an efficient, reliable CDU.

Discover a selection of our products here, and find the full portfolio at datacenters.danfoss.com

As global HVAC leaders, we are reknowned for our advanced technologies, quality and strong supply chain. Whatever you need to ensure optimum thermal management in your liquid-cooled data centers, we have you covered.



Temperature and pressure sensors



Strainers and shut-off valves



Controllers and software



Brazed plate heat exchangers

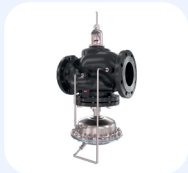

Pressure independent control valves and actuators



Variable frequency drives

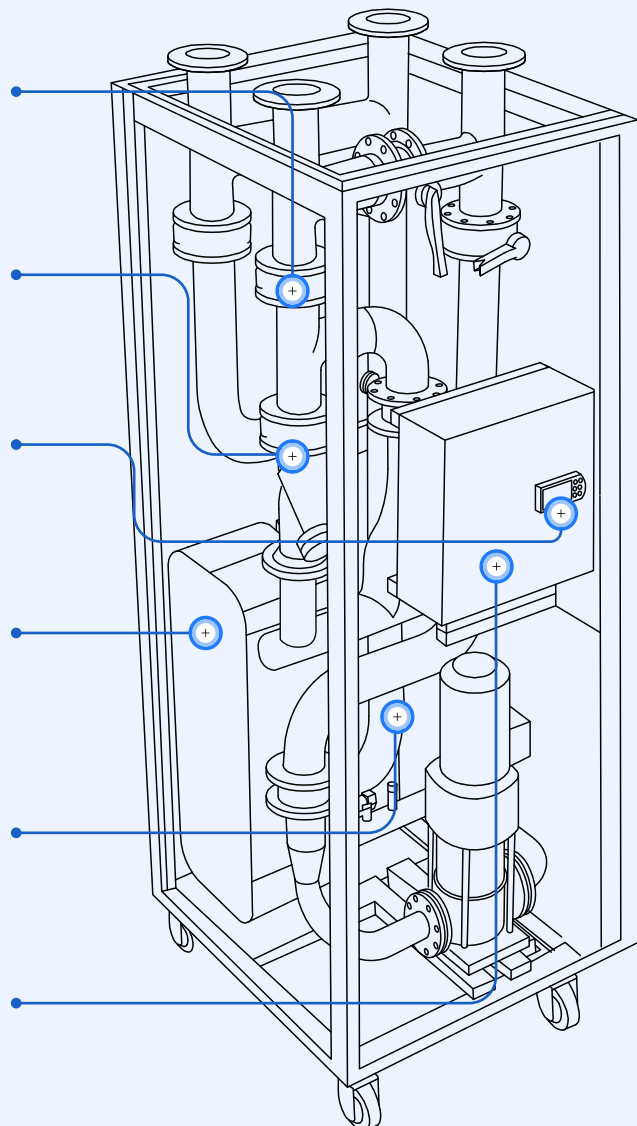



DIGITAL EXPERIENCE
Click/tab the QR codes to learn more about the products



Alsmart® for fast, reliable, and customizable control



Discover Alsmart

Alsmart® gives you a programmable and highly secure HVAC controller platform. With best-in-class hardware, intuitive programming, and remote monitoring, you get an intelligent, compact and powerful brain for your CDU.



Get eBook:
Master your HVAC symphony



Heat exchangers for superior thermal management



Brazed plate heat exchangers
Optimized for efficient performance in liquid-to-liquid applications. Our CDU optimized portfolio offers approach temperatures of 2°C to 4°C with capacities up to 1.3 MW in a single unit.

Brazed and gasketed heat exchangers provide efficient, tailored solutions for data center applications.



Gasketed plate heat exchangers
Diverse range of close approach optimized heat exchangers, engineered to meet the needs of future 2+MW CDUs or deconstructed CDU skid builds, ensuring tailored solutions for your specific requirements.



Variable frequency drives for maximum efficiency and uptime



iC7 series
Meet the most energy-efficient variable frequency drive solution on the market. iC7 drives give you built-in functionalities, such as Automatic Energy Optimization, ensuring optimal pump efficiency and reducing energy consumption and costs.



In data centers, uptime is paramount. With Danfoss' condition-based monitoring solutions, you can proactively detect potential issues like motor stator winding deterioration, pump load, and cavitation to enhance predictive maintenance and minimize downtime.



Harmonic mitigation for cutting the risk of downtime
Harmonic distortion equals downtime. With Danfoss, you get a comprehensive range of harmonic mitigation solutions, including ultra low-harmonic (ULH) drives, active front-end (AFE) drives, and passive filters, to safeguard systems from harmonic-related failures.



Sensors for reliable operation

DST P110 and DST P140
High-quality pressure sensors for liquid cooling system water cycles. DST P110 ensures superior accuracy for precision cooling, DST P140 brings advanced oil-filled MEMS technology to provide high overload and burst capabilities.



DST P110



DST P140



MBT 3270
Meet highest accuracy standards with temperature sensors for reliable and customized condition monitoring.



MBT 3560
For use in Data Center mission critical applications where reliable, robust and accurate equipment is required.



DIGITAL EXPERIENCE
Click/tab the QR codes to learn more about the products



Pressure independent valves for high-accuracy flow control and hydronic independence

Get maximum flow control accuracy and hydronic independence between CDU units with pressure independent valves with 100% authority.

AB-QM with NovoCon®
Balance and control hydronic flows and enable data collection with digital actuators with bus-communication.

AFQM 2 with AME 659SD
Balance and control hydronic flows with modulating gear actuators with TÜV certified Spring Down safety function.



AB-QM



NovoCon®



AFQM 2



AME 659SD



Strainers and shut-off valves for reliable unit operation and serviceability



FVF Strainers
Protect CDU components by preventing particles from being transported and enable the use of draining ball valves to remove them.



VFY-LH butterfly valves
Enable simple temporary flow stops for service or maintenance.

From the CDU to the chip

Go with the smart flow

– go with ready-built valve trains to connect your CDU to server racks



Smart, customizable valve trains for efficient liquid cooling

With Danfoss CoolTrain™ you get a plug-n-play solution all the way from your CDU to the racks and back. Made of corrosion-resistant material and field-proven in glycol systems up to 40%, these valve trains balance and control hydronic liquid cooling system flows.

Danfoss CoolTrain™ is delivered pre-assembled in any configuration, quality tested, and meticulously cleaned before being PG25 filled and sealed.



Optimize and validate with expert simulation

We offer application expertise, model-based design to accelerate development, digital twins for virtual testing and benchmarking, simulation services to validate system layouts, and testing capabilities in our Application Development Centers. Partner with us to enhance performance, shorten your time-to-market, and reduce design uncertainty.

As an end-to-end development partner, our expertise extends across the entire data center ecosystem:

Configuration example 1: In-row CDU installation

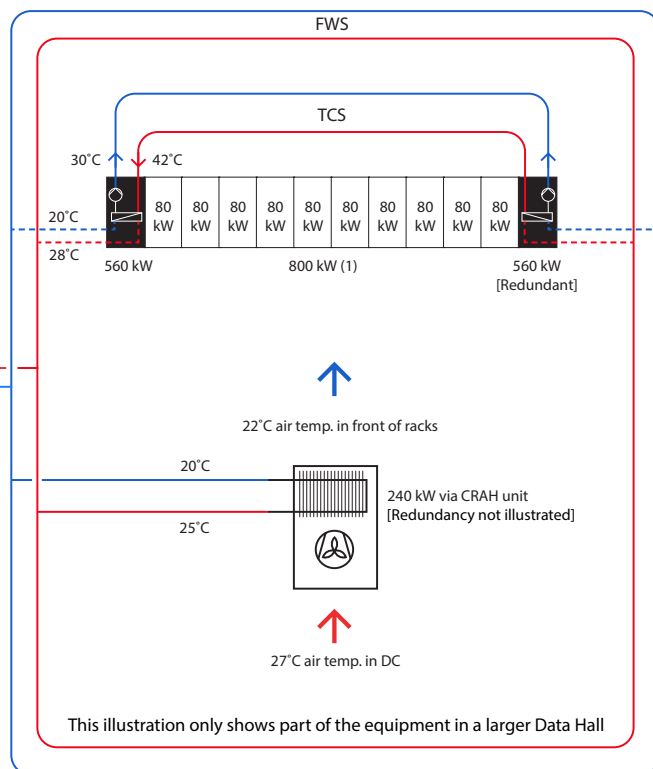

Commonly deployed in data centers with a low degree of liquid cooling needed, i.e. in retrofit for legacy air-cooled data centers.

- Short loop lengths for reduced pressure loss
- Modular, scalable solution for gradual expansion options can combine a hybrid cooling approach to cool specific areas or components with high heat density

Legend:

(1) Heat removal split 70% liquid cooled (via cold plates directly on the processors) and 30% air cooled (via CRAH unit, fan wall or similar). The 240 kW CRAH unit and the 560 kW CDU together would cover the 800 kW load (without redundancy).

■ = CDU □ = Rack with liquid cooled servers

Technical glossary

FWS: Facility Water System. Normal chilled water, 20-30% glycol, normal conductivity, 250 or 500 micron filtration. Typically a PN 10 system. DN 150-400.

TCS: Technology Cooling System. Special treated water with up to 25% glycol, very low conductivity, 50 micron filtration. Typically a closed system precharged to 2.5-3.0 bar only. ≤ DN 100.

Configuration example 2: External CDU installation

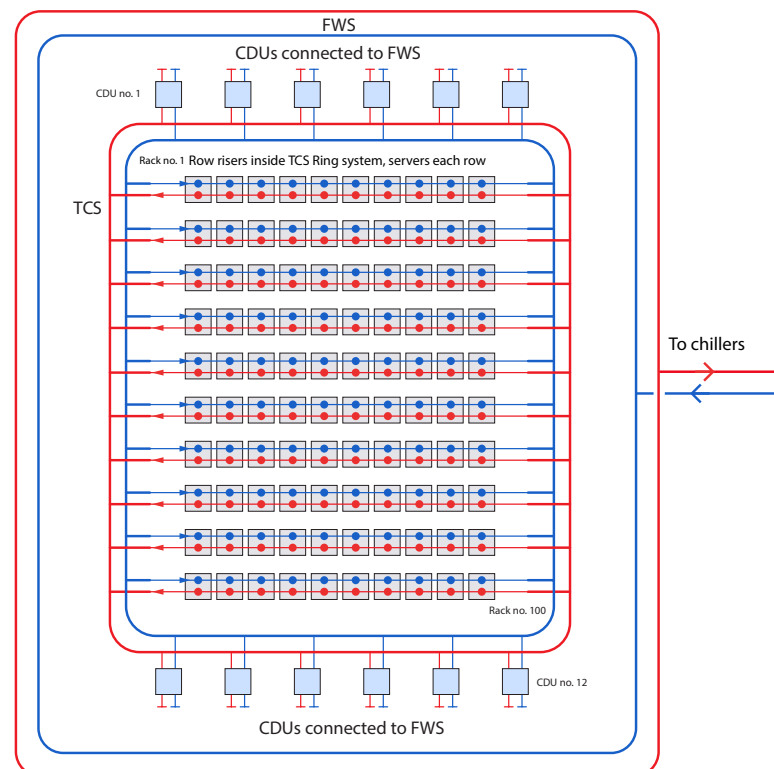

For CDU installation outside the data hall. Feeds into a distributed ring system supplying the entire data center. Excellent for new-built data centers with dedicated TCS ring distribution systems, and for mixed deployments.

- Frees up space in the data hall for more racks
- Easier service and technical room access
- Higher pump efficiency for lower OPEX
- Enhanced supply temperature control

Explore our solutions
datacenters.danfoss.com

Danfoss



Danfoss A/S
Nordborgvej 81
6430 Nordborg
Denmark
danfoss@danfoss.com
CVR reg. no. 20165715



© Danfoss 2026.04

Any information, including, but not limited to information on selection of product, its application or use, product design, weight, dimensions, capacity or any other technical data in product manuals, catalogues descriptions, advertisements, etc. and whether made available in writing, orally, electronically, online or via download, shall be considered informative, and is only binding if and to the extent, explicit reference is made in a quotation or order confirmation. Danfoss cannot accept any responsibility for possible errors in catalogues, brochures, videos and other material. Danfoss reserves the right to alter its products without notice. This also applies to products ordered but not delivered provided that such alterations can be made without changes to form, fit or function of the product. All trademarks in this material are property of Danfoss A/S or Danfoss group companies. Danfoss and the Danfoss logo are trademarks of Danfoss A/S. All rights reserved.

AD536172581165en-000102