



High performance in challenging environments





Built to last, VLT® AutomationDrive FC 360 operates effectively and reliably even in the most challenging environments and applications.

Performance, reliability and speed

Increase quality and efficiency with energy-efficient, user-friendly control of motors from 0.37 to 315 kW.

Built on the success of the tried and tested VLT® platform that Danfoss developed and launched in the 1960's, the VLT® AutomationDrive FC 360 shares the same technical heritage as the popular and versatile VLT® AutomationDrive FC 300 series. Developed to meet a general purpose operation profile the drive lacks the expandability of its larger sibling, but still delivers powerful performance out of the box.

Because all Danfoss drives follow the same basic design and operating principle, existing owners and users of VLT® drives will instantly feel at home with the FC 360.

The FC 360 is a dedicated industry drive. It provides precise and efficient motor control in a wide range of industrial applications.

Built-in features help owners save

- Installation space
- Setup time
- Maintenance time

The result is a powerful and versatile solution that increases process efficiency and quality in a cost-efficient package.





Built-in features facilitate high performance and fewer external components. This reduces complexity and makes the ordering process easier.

Reduced Harmonics

A built-in DC choke reduces harmonics to 40-48% THDi and significantly extends the lifetime of the DC capacitor.

Designed for challenging environments

The internal electronics of the FC 360 are protected by a high quality, advanced coating. This coating provides the rugged characteristics demanded by the textile, plastics, rubber, food, beverage, and building materials industries.

Maximize productivity

IP20 standard protection and an easy-to-use control panel saves valuable time in commissioning and maintenance, and enables owners to maximize uptime and conserve energy.

Compact design for easy installation

The compact, lightweight design enables owners to optimize panel space by mounting several drives side-by-side mounting with zero clearance.

Save time on setup

Easy parameter setup makes the path to energy savings both short and simple, and can be carried out with an enhanced numeric LCP or graphical control panel that supports English, Chinese and Portuguese. Targeted 'Application Selections' make it easy for users to set up and commission typical applications.



High reliability

Coated printed circuit boards

High level 3C3 Printed Circuit Board (PCB) coating as standard provides high reliability in harsh environments to prevent failures and downtime. The lifetime of the drive is also increased as a result of the IEC 60721-3-3 conformal coating.

55 °C working temperature

VLT® AutomationDrive FC 360 is designed to operate at 45-50°C ambient temperature at full load (depending on model) and 55°C with derating. This means there is no need to install extra cooling equipment or over-dimension the drive, resulting in cost savings.

Efficient heat management

A unique cooling concept ensures that there is no forced air flow over the electronics. This reduces the risk of downtime, while strengthening stability in daily operation.

By preventing dust and particles from accumulating on the small internal components and legs, the risk of short circuits is significantly reduced, especially in humid environments.

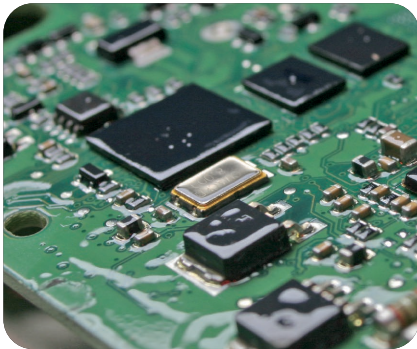

Coated PCB

The VLT® AutomationDrive FC 360 is delivered with a 3C3 class coated PCB as standard to strengthen reliability.



Easy cleaning

An easy-to-remove fan makes it easy to keep dust from affecting the drive's ventilation.



Display

Customer can select an enhanced numerical display or graphical control panel that supports English, Chinese and Portuguese.



Enclosure

The VLT® AutomationDrive FC 360 is available with an IP20 enclosure.

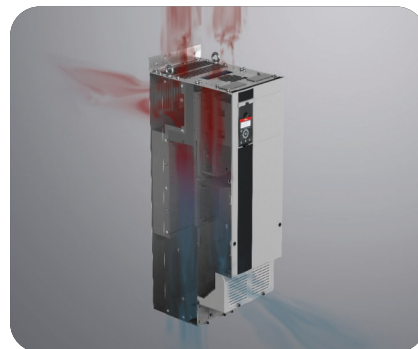

Separation

Total separation between the back-channel cooling air and the internal electronics to ensure efficient cooling



Rear air cooling channel

By directing air through a rear cooling channel up to 90% of the drive's heat loss is removed directly outside the installation room.

Optimized for industrial applications

- Extruders
- Escalators
- Winders
- Material handling
- Stacking machine
- Shelf lift
- Rail-guided vehicle (RGV)
- Conveyor
- Draw bench
- Textile machinery
- Petrochemical
- Hoist
- Air compressor
- Printing & dyeing
- Glass production line
- Centrifuge separators
- Pumps
- Fans
- Mixers

High performance controller

VLT® AutomationDrive FC 360 has an advanced controller with a high speed response, making high-end, complicated applications easy.

450 kg force at 0.6 Hz

The high torque performance of a 0.75 kW VLT® AutomationDrive FC 360 fully meets the demands for tensile testing at Samuya Technocrates in India.

Speed

PM motor control

The FC 360 can provide highly efficient permanent magnet (IPM/SPM) motor control in open loop under VVC+ mode and Flux Basic open/closed loop for all power ranges. Using Automatic Motor Adaptation (AMA) the drive adapts to the specific characteristics of the permanent magnet motor.

Smart Logic Control

Smart Logic is a simple and clever way to keep the drive, motor and application working together. The smart logic controller monitors a specific event, and when it occurs, it triggers a pre-defined action which is monitored for 20 steps, before returning to step 1.

The Smart Logic controller can monitor any parameter that can be defined as "true" or "false", providing users with significant freedom to tailor the control strategy to their specific needs. This includes digital commands and logic

expressions, where sensor outputs can influence operation using parameters such as temperature, pressure, torque, flow, time, load, frequency, voltage, and others, combined with the operators ">", "<", "=", "and" and "or" as logical statements.

Expand with control and feedback modules

Fieldbus communication in the VLT® AutomationDrive FC 360 is integrated in the control card. In addition, the drive can be expanded with options for additional control and encoder feedback.

With the VLT® Encoder Input MCB 102 and VLT® Resolver Input MCB 103 the VLT® AutomationDrive FC 360 can receive encoder feedback from either a motor or a process.

Time-saving setup VLT® Motion Control Tool MCT 10

The FC 360 can be configured and monitored with Danfoss' own VLT® Motion Control Tool MCT 10 software. This provides plant managers with a comprehensive overview of the system at any point in time and a high level of flexibility in configuration and monitoring.

MCT 10 is a Windows-based engineering tool with a clearly structured interface that provides an instant overview of all the drives in a system of any size. The software runs under Windows and enables data exchange over a traditional RS 485 interface or fieldbus (PROFIBUS, PROFINET, and EtherNet IP).

Parameter configuration is possible both online and offline, and the software can be configured to link to the system's electrical diagrams or operating manuals. This helps to reduce the risk of incorrect configuration while offering fast access to troubleshooting.

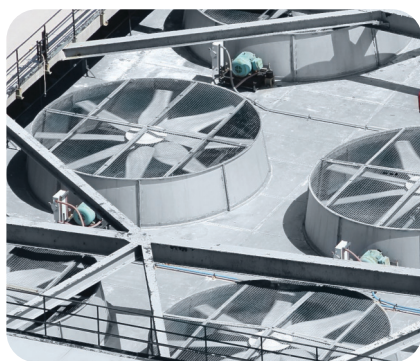

Use with VLT® OneGearDrive®

The VLT® AutomationDrive FC 360 is designed to work perfectly with permanent magnet motors, such as the VLT® OneGearDrive®, which is widely used in the Danfoss VLT® FlexConcept®.



Easy Setup via PC

Connect the VLT® AutomationDrive FC 360 directly to a PC for fast and easy transfer of settings.

Features designed to meet industrial needs

The VLT® AutomationDrive FC 360 is designed to provide maximum uptime and reliability in a wide range of environments.

Built-in brake chopper

A built-in brake chopper up to 22 kW saves money and panel space.

Pulse input as speed reference

Convert pulse input as a speed reference, avoiding the need to purchase an analog signal module for PLC.

Built-in PID controller

The built in PID controller calculates an 'error' value as the difference between a measured process variable and a desired setpoint.

Built-in RFI filter

Built-in filters not only save space, but also eliminate additional costs for fitting, wiring, and material. The most important advantage is the perfect EMC conformance and cabling of integrated filters.

Positioning

With the integrated encoder input or MCB option, the positioning control includes features such as homing, position-reference setting, position feedback and PID control. It supports both absolute positioning and relative positioning applications, such as stacking machines, shelf lifts or rail-guided vehicles.

Torque closed-loop control

Torque closed-loop control actualizes the functionality through encoder feedback; both terminal 32/33 pulse inputs and MCB102 inputs are available.

PM motor control

The FC 360 supports synchronous motor control, including Surface Placed Magnets (SPM) and Interior Placed Magnets (IPM).

Communicative

The FC 360 communicates using your preferred choice of process automation protocols:

- PROFIBUS
- PROFINET with dual port
- Modbus RTU and FC Protocol are integrated as standard
- Ethernet IP with dual port

Designed for a wide range of power supply conditions, the FC 360 can operate at -15% of supply voltage



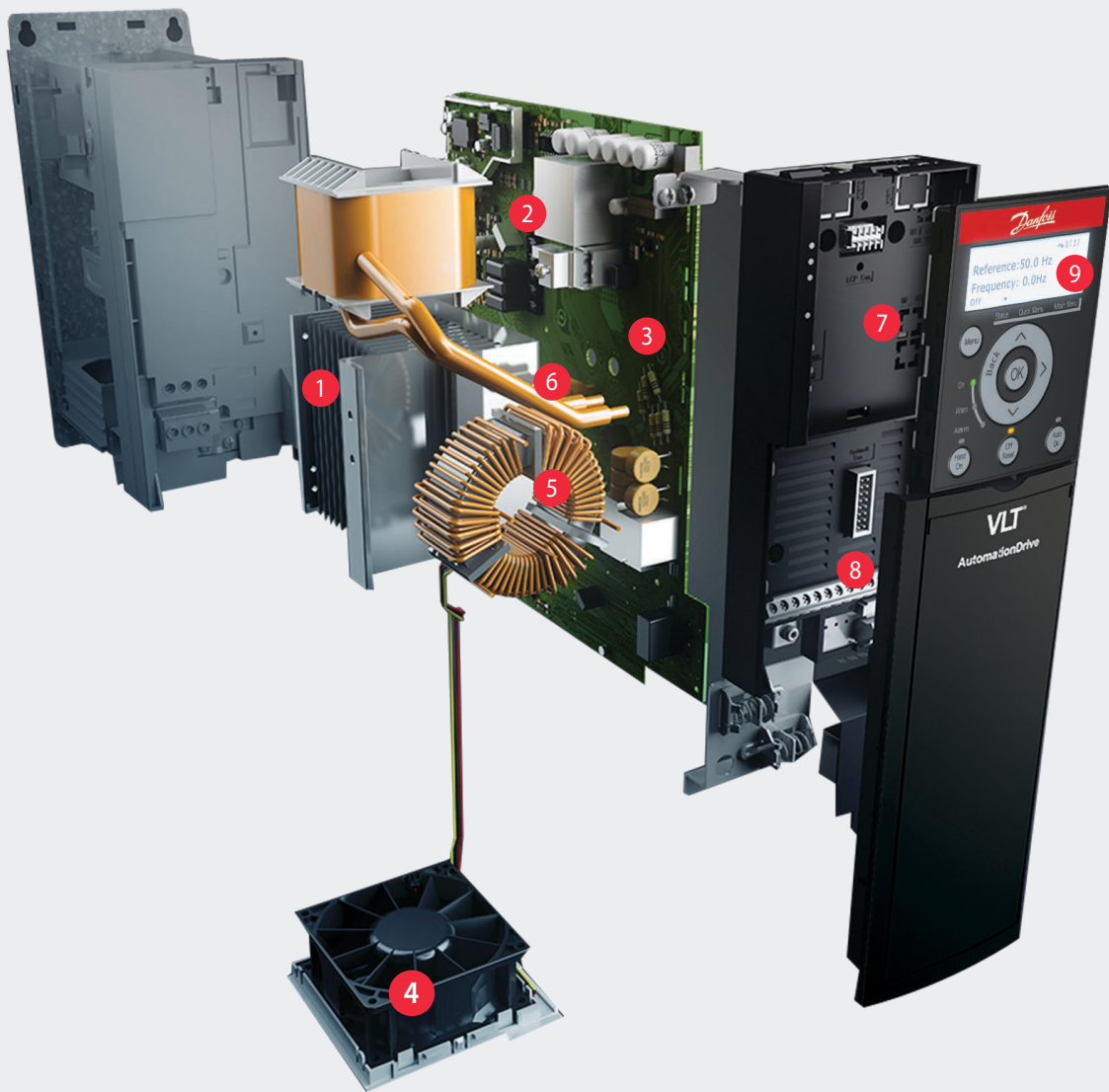

1 Designed for use in ambient temperatures up to 40-50 °C without derating. Max. ambient temperature 55 °C

2 No forced air over PCB for whole power range

3 Class 3C3 coated components for increased reliability in harsh environments (IEC 60721-3-3)

4 Removable fan

5 Integrated EMC filter

6 Built-in brake chopper up to 22 kW

7 Fieldbus embedded in control card (FC Protocol, Modbus RTU, Options: PROFIBUS, PROFINET, and EtherNet IP)

8 I/O number and functions
 – 7DI / 2AI / 2AO / 2 DO
 – Pulse input as speed reference
 – Pulse feedback and 24 V encoder feedback
 – 24 V (100 mA)
 – 12 V

9 Display options
 – Graphic LCP
 – Enhanced numeric LCP
 – Blind cover

* Fully automatic motor adaptation (AMA) optimizes compatibility between drive and motor in VVC+ mode

* Built-in Smart Logic Controller

* RFI Switch

** Not visible on picture*

[▶ Watch the video here](#)

Specification

(Basic unit without extensions)

Main supply (L1, L2, L3)	
Supply voltage	J1-J7: 380-480 V -15%/+10% J8-J9: 380-480 V -10%/+10%
Supply frequency	50/60 Hz ±5%
Displacement power factor (cos φ)	> 0,98
Switching on input supply L1, L2, L3	0.37-7.5 kW maximum 2 times/min. 11-315 kW maximum 1 time/min.
Harmonic disturbance	Meets EN 61000-3-12
Output data (U, V, W)	
Output voltage	0-100% of supply voltage
Output frequency	Induction motor: V/F mode: 0-500 Hz VVC+ mode: 0-200 Hz Flux basic mode: 0-200 Hz
	PM motor: VVC+ mode: 0-400 Hz Flux basic mode: 0-300 Hz
Switching on output	Unlimited
Ramp times	0.01-3600 sec
<i>Note: 150%/110% current can be provided for 1 minute. Higher overload rating is achieved by oversizing the drive.</i>	
Digital inputs	
Programmable digital inputs	7
Changeable to digital output	2 (Terminal 27,29)
Logic	PNP or NPN
Voltage level	0 – 24 V DC
Maximum voltage on input	28 V DC
Input resistance, Ri	Approx. 4 kΩ
Scan interval	1 ms
<i>* 2 can be used as digital outputs</i>	
Analog inputs	
Analogue inputs	2
Modes	Voltage or current
Voltage level	0 to +10 V (scaleable)
Current level	0/4 to 20 mA (scaleable)
Accuracy of analog inputs	Max. error 0.5% of full scale
Pulse/encoder inputs	
Programmable pulse/encoder inputs	2/1
Voltage level	0 – 24 V DC (PNP positive logic)
Pulse input accuracy (0.1 – 1 kHz)	Max. error: 0.1% of full scale
Encoder input accuracy	4 Hz-32 kHz
<i>* Utilize some of the digital inputs</i>	

Digital outputs	
Programmable digital/pulse outputs	2
Voltage level at digital/frequency output	0-24 V DC
Max. output current (sink or source)	40 mA
Maximum output frequency at frequency output	4 Hz to 32 kHz
Accuracy on frequency output	Max. error: 0.1% of full scale
<i>* Utilize 2 digital inputs</i>	
Analogue output	
Programmable analogue outputs	2
Current range at analogue output	0/4 – 20 mA
Max. load to common at analogue output (clamp 30)	500 Ω
Accuracy on analogue output	Max. error: 0.8 % of full scale
Control card	
RS485 interface	Up to 115 kBaud
Max. load (10 V)	15 mA
Max. load (24 V)	100 mA
Relay output	
Programmable relay outputs	2
Max. terminal load (AC) on 1-3 (break), 1-2 (make), 4-6 (break) power card	250 V AC, 3 A
Max. terminal load (AC) on 4-5 (make) power card	250 V AC, 3 A
Min. terminal load on 1-3 (break), 1-2 (make), 4-6 (break), 4-5 (make) power card	250 V AC, 0,2 A
Surroundings/external	
Enclosure	IP20
Vibration test	1.0 g
Max. relative humidity	5-95% (IEC 60721-3-3; Class 3K3 (non-condensing) during operation)
Ambient temperature	40-50 °C
Galvanic isolation of all	I/O supplies according to PELV
Aggressive environment	Class 3C3
Fieldbus communication	
Standard built-in	FC Protocol Modbus RTU
Fieldbus built-in control card variants	PROFIBUS, PROFINET, and EtherNet IP

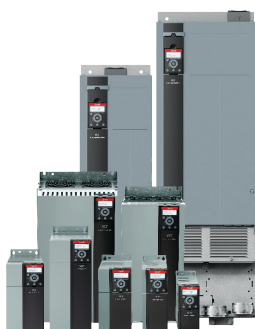

Connection examples

The numbers represent the terminals on the driv

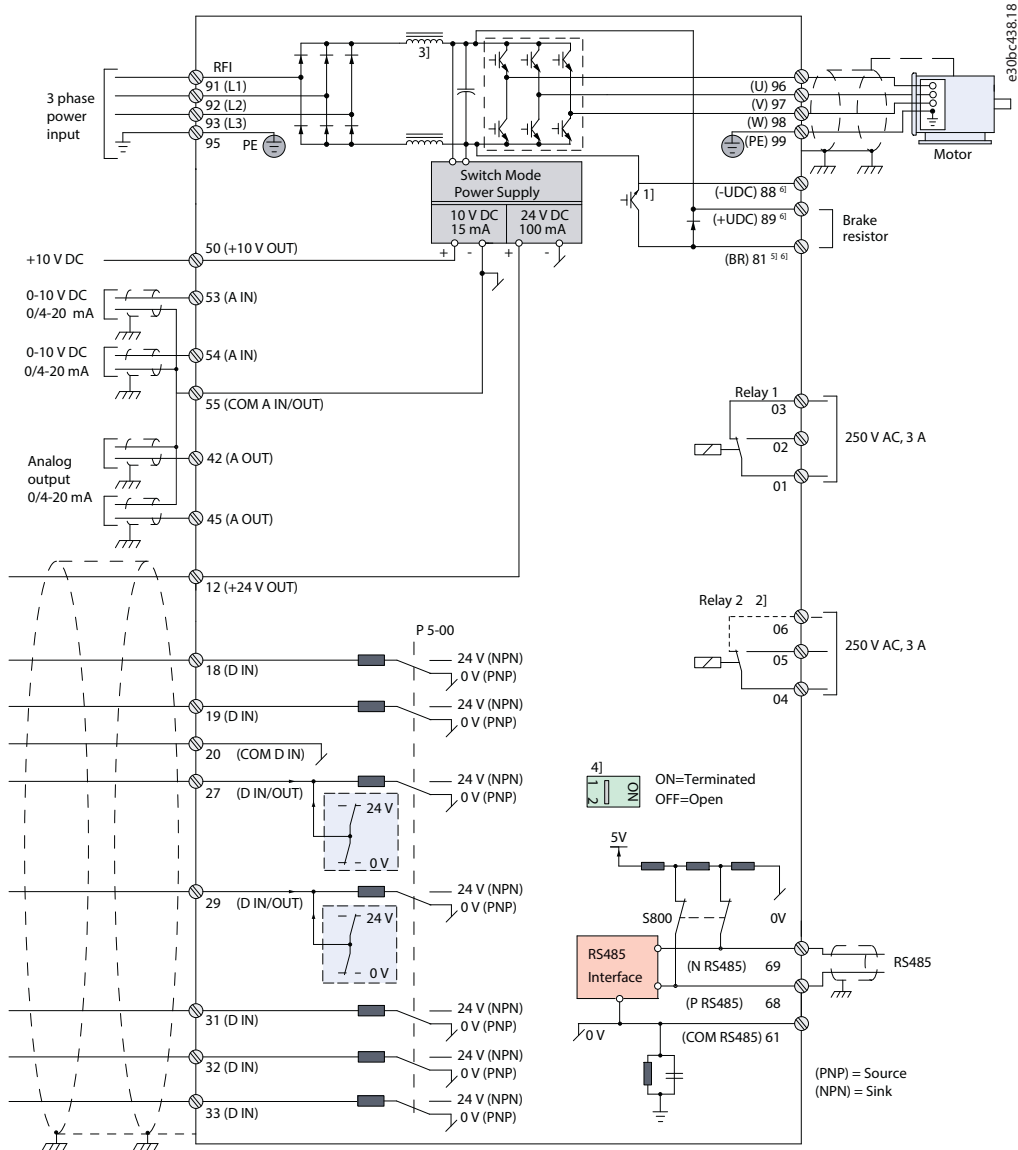

- ¹⁾ Built-in brake chopper available from J1–J5.
- ²⁾ Relay 2 is 2-pole for J1–J3 and 3-pole for J4–J9. Relay 2 of J4–J9 with terminals 4, 5, and 6 has same NO/NC logic as relay 1. Relays are pluggable in J1–J5, and fixed in J6–J9
- ³⁾ Single DC choke in J1–J5, Dual DC choke in J6–J9.
- ⁴⁾ Switch S800 (bus terminal) can be used to enable termination on the RS485 port (terminals 68 and 69).
- ⁵⁾ No BR for J6–J9.
- ⁶⁾ No terminal 81, 88 and 89 for J8 and J9

The diagram shows the port terminals of the VLT® AutomationDrive FC 360.

The numbers indicated refer to the terminal numbers of the drives.

Set the mode of the analogue inputs 53 and 54 by setting software parameters.

The FC 360 features a RS485 interface as standard. The RS485 terminations are integrated in the drive (S800).

PROFIBUS, PROFINET or Ethernet IP can be specified by configuring different control cassette when ordering.

To switch from NPN to PNP logic for the digital signals, use parameter 5-00.

Ordering model code and electrical data

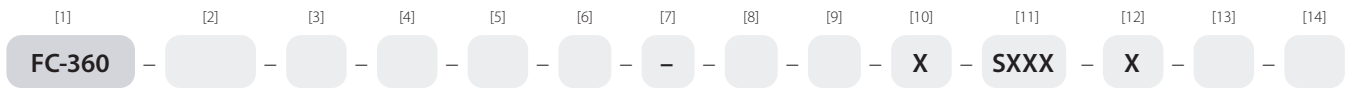

[1] Application	
360	VLT® AutomationDrive FC 360
[2] Power Size	
HK37/ QK37	
HK55/ QK55	
HK75/ QK75	
H1K1/ Q1K1	
H1K5/ Q1K5	
H2K2/ Q2K2	
H3K0/ Q3K0	
H4K0/ Q4K0	
H5K5/ Q5K5	
H7K5/ Q7K5	
H11K/ Q11K	
H15K/ Q15K	
H18K/ Q18K	
H22K/ Q22K	

See ratings data on page 12-13 for power ratings

H30K/ Q30K	
H37K/ Q37K	
H45K/ Q45K	
H55K/ Q55K	
H75K/ Q75K	
H90K/ Q90K	
H110/ Q110	
H132/ Q132	
H160/ Q160	
H200/ Q200	
H250/ Q250	
Q315	
[3] AC Line Voltage	
T4	3 x 380/480 V AC (high overload) 3 x 380/480 V AC (normal overload)
[4] Enclosure	
For cabinet mounting:	
E20	IP20/Chassis
[5] RFI Filter (EN 55011)	
H2	RFI-Filter, Class A2 (C3)

See ratings data on page 12-13 for power ratings

[6] Braking	
X	No brake IGBT
B	Built-in brake IGBT 1]
[7] Display (Local Control Panel)	
X	No LCP, blind cover ²⁾
[8] Conformal coating (IEC 60721-3-3)	
C	Conformal coating on all PCBs
[9] Mains Input	
X	No mains option ³⁾
D	Load-sharing terminals
[10] Cable	
X	Standard cable entry
[13] Fieldbus embedded in control cassette ⁴⁾	
AX	No fieldbus option
A0	PROFIBUS
AL	PROFINET
AN	EtherNet IP
[14] B Option (Application)	
BX	No application option ⁵⁾

¹⁾ 0.37-22kW built-in; 30-315 kW without brake IGBT
²⁾ Following accessories available: Numeric and graphical LCP and blind cover
³⁾ J8, J9 has no mains option
⁴⁾ Normal overload products are available in AX and AL versions only
⁵⁾ VLT® Encoder Input MCB 102, VLT® Resolver Input MCB 103 and VLT® Sensor Input MCB 114 available as accessories

380-480 V AC

Enclosure		IP20	J1					J2			J3	
		HO ¹⁾ (NO) ¹⁾	HK37 QK37	HK55 QK55	HK75 QK75	H1K1 Q1K1	H1K5 Q1K5	H2K2 Q2K2	H3K0 Q3K0	H4K0 Q4K0	H5K5 Q5K5	H7K5 Q7K5
Typical shaft output		[kW]	0.37	0.55	0.75	1.1	1.5	2.2	3	4	5.5	7.5
Typical shaft output at 460 V		[HP]	0.5	0.75	1	1.5	2	3	4	5.5	7.5	10
Output current (3 x 380-440 V)	Continuous	[A]	1.2	1.7	2.2	3	3.7	5.3	7.2	9	12	15.5
Output current (3 x 441-480 V)	Continuous	[A]	1.1	1.6	2.1	3	3.4	4.8	6.3	8.2	11	14
Intermittent (60 s overload)	HO	[A]	1.9	2.7	3.5	4.8	5.9	8.5	11.5	14.4	19.2	24.8
	NO	[A]	1.3	1.9	2.4	3.3	4.1	5.8	7.9	9.9	13.2	17.1
Output power (400 V AC)	Continuous	[kVA]	0.8	1.2	1.5	2.1	2.6	3.7	5.0	6.2	8.3	10.7
Output power (460 V AC)	Continuous	[kVA]	0.9	1.3	1.8	2.5	2.8	4	5.2	6.8	9.2	11.6
Max. cable size (Mains, motor, brake and load sharing)		[mm ²] ([AWG])	4 mm ²									
Max. input current (3 x 380-440 V)	Continuous	[A]	1.2	1.6	2.1	2.6	3.5	4.7	6.3	8.3	11.2	15.1
Max. input current (3 x 441-480 V)	Continuous	[A]	1	1.2	1.8	2	2.9	3.9	4.3	6.8	9.4	12.6
Intermittent (60 s overload)	HO	[A]	1.9	2.6	3.4	4.2	5.6	7.5	10.1	13.3	17.9	24.2
	NO	[A]	1.3	1.8	2.3	2.9	3.9	5.2	6.9	9.1	12.3	16.6
Max. pre-fuses		[A]	10					25				
Estimated power loss at rated max. load		[W]	20.8	25.1	30	40	52.9	73.9	94.8	115.5	157.5	192.8
		[kg]	2.3	2.3	2.3	2.3	2.3	2.5	3.6	3.6	3.6	4.1
Weight (IP20)		[lb]	5.1	5.1	5.1	5.1	5.1	5.5	7.9	7.9	7.9	9.0
			0.96					0.97				
Efficiency			0.96					0.98				

¹⁾ HO: High overload 150% 1 min/10 min
 NO: Normal overload 110% 1 min/10 min

380-480 V AC

Enclosure		IP20	J4		J5		J6			
		HO ¹⁾	H11K	H15K	H18K	H22K	H30K	H37K	H45K	
		(NO) ¹⁾	Q11K	Q15K	Q18K	Q22K	Q30K	Q37K	Q45K	
Typical shaft output		[kW]	11	15	18	22	30	37	45	
Typical shaft output at 460 V		[HP]	15	20	25	30	40	50	60	
Output current (3 x 380-440 V)	Continuous	[A]	23	31	37	42.5	61	73	90	
Output current (3 x 441-480 V)	Continuous	[A]	21	27	34	40	52	65	80	
Intermittent (60 s overload)	HO	[A]	34.5	46.5	55.5	63.8	91.5	109.5	135	
	NO		25.3	34.1	40.7	46.8	67.1	80.3	99	
Output power (400 V AC)	Continuous	[kVA]	15.9	21.5	25.6	29.5	42.3	50.6	62.4	
Output power (460 V AC)	Continuous	[kVA]	17.5	22.5	28.3	33.3	43.2	54	66.5	
Max. cable size (Mains, motor, brake and load sharing)		[mm ²] ([AWG])	16 mm ²				50 mm ²			
Max. input current (3 x 380-440 V)	Continuous	[A]	22.1	29.9	35.2	41.5	57	70.3	84.2	
Max. input current (3 x 441-480 V)	Continuous	[A]	18.4	24.7	29.3	34.6	49.2	60.6	72.2	
Intermittent (60 s overload)	HO	[A]	33.2	44.9	52.8	62.3	85.5	105.45	126.3	
	NO		24.3	32.9	38.7	45.7	62.7	77.3	92.6	
Max. pre-fuses		[A]	50		80		160			
Estimated power loss at rated max. load		[W]	289.5	393.3	402.8	467.5	630	848	1175	
Weight (IP20)		[kg]	9.4	9.5	12.3	12.5	22.4	22.5	22.6	
		[lb]	20.7	20.9	27.1	27.6	49.4	49.6	49.8	
Efficiency									0.98	

¹⁾ HO: High overload 150% 1 min/10 min

NO: Normal overload 110% 1 min/10 min

380-480 V AC

Enclosure		IP20	J7			J8			J9				
		HO ¹⁾	H55K	H75K	H90K	H110	H132	H160	H200	H250			
		(NO) ¹⁾	Q55K	Q75K	Q90K	Q110	Q132	Q160	Q200	Q250	Q315		
Typical shaft output		[kW]	55	75	90	90	110	132	160	160	200	250	315
Typical shaft output at 460 V		[HP]	75	100	125	125	150	200	250	250	300	350	450
Output current (3 x 380-440 V)	Continuous	[A]	106	147	177	177	212	260	315	315	395	480	588
Output current (3 x 441-480 V)	Continuous	[A]	96	124	160	160	190	240	302	302	361	443	535
Intermittent (60 s overload)	HO	[A]	159	220.5	195	266	318	390	347	473	593	720	647
	NO		116.6	161.7	195	266	233	286	347	473	435	528	647
Output power (400 V AC)	Continuous	[kVA]	73.4	101.8	123	123	147	180	218	218	274	333	407
Output power (460 V AC)	Continuous	[kVA]	79.8	103.1	127	127	151	191	241	241	288	353	426
Max. cable size (Mains, motor, brake and load sharing)		[mm ²] ([AWG])	50 mm ² 95 mm ²			2x95			(2x3/0)				
Max. input current (3 x 380-440 V)	Continuous	[A]	102.9	140.3	171	171	204	251	304	304	381	463	567
Max. input current (3 x 441-480 V)	Continuous	[A]	88.6	120.9	154	154	183	231	291	291	348	427	516
Intermittent (60 s overload)	HO	[A]	154.35	210.45	188.1	256.5	306	376.5	334.4	456	571.5	694.5	623.7
	NO		113.2	154.3	188.1	256.5	224.4	281.6	334.4	456	418	504	623.7
Max. pre-fuses		[A]	250	315	315	315	350	400	550	550	630	800	800
Estimated power loss at rated max. load		[W]	1300	1507	2031	2031	2289	2923	3093	3093	4039	5004	6674
Weight (IP20)		[kg]	37.3	38.7		98			164				
		[lb]	82.2	85.3		216			362				
Efficiency									0.98				

¹⁾ HO: High overload 150% 1 min/10 min

NO: Normal overload 110% 1 min/10 min

Dimensions

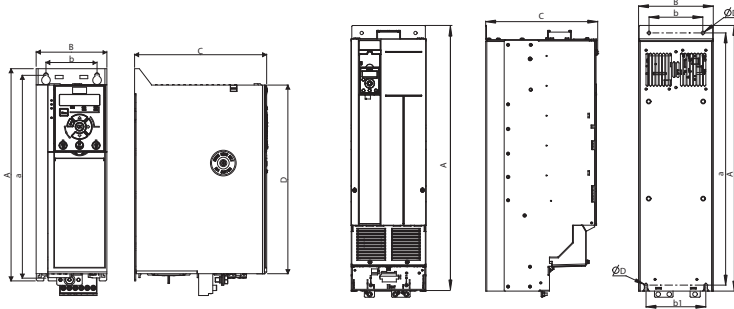

Enclosure size 380-480 V	J1	J2	J3	J4	J5	J6	J7	J8	J9
Height A [mm (in)]	210 (8.3)	272.5 (10.7)	272.5 (10.7)	317.5 (12.5)	410 (16.1)	515 (20.3)	550 (21.7)	889 (35.0)	1096 (43.1)
Height A ¹⁾ [mm (in)]	–	–	–	–	–	–	–	909 (35.8)	1122 (44.2)
Width B [mm (in)]	75 (3.0)	90 (3.5)	115 (4.5)	133 (5.2)	150 (5.9)	233 (9.2)	308 (12.1)	250 (9.8)	350 (13.8)
Depth C [mm (in)]	168 (6.6)	168 (6.6)	168 (6.6)	245 (9.6)	245 (9.6)	241 (9.5)	323 (12.7)	375 (14.8)	375 (14.8)
Depth C ²⁾ [mm (in)]	173 (6.8)	173 (6.8)	173 (6.8)	250 (9.8)	250 (9.8)	241 (9.5)	323 (12.7)	–	–
D [mm (in)]	180 (7.1)	240 (9.4)	240 (9.4)	270 (10.6)	364.7 (14.4)	452 (17.8)	484.5 (19.0)	–	–
Mounting holes									
a [mm (in)]	198 (7.8)	260 (10.2)	260 (10.2)	297.5 (11.5)	390 (15.4)	495 (19.5)	521 (20.5)	844 (33.2)	1051 (41.4)
b [mm (in)]	60 (2.4)	70 (2.8)	90 (3.5)	105 (4.1)	120 (4.7)	200 (7.9)	270 (10.6)	180 (7.1)	280 (11.0)
b1 [mm (in)]								200 (7.9)	271 (10.7)
Mounting screw	M4	M5	M5	M6	M6	M8	M8	M8	M8

¹⁾ Note: Including decoupling plate.

²⁾ Note: With option B.

Accessories

HMI

VLT® Control Panel LCP 21 (Numeric)

Ordering number: 132B0254

VLT® Control Panel LCP 23 (Graphical)

Ordering number: 132B0801

VLT® Control Panel LCP Blind Cover

Ordering number: 132B0262

LCP Panel Mounting Kit

Ordering number:

132B0102: with fasteners, gasket and without LCP
and with 3 m (10 ft) cable

LCP Remote Mounting Cable, 3 m (10 ft)

Ordering number: 132B0132

VLT® Control Panel LCP 21 - RJ45 Converter Kit

Ordering number: 132B0254

MCB options

VLT® Encoder Input MCB 102

Ordering number: 132B0282

VLT® Resolver Input MCB 103

Ordering number: 132B0283

VLT® Sensor Input MCB 114

Ordering number: 130B1272

VLT® 24 V DC Supply MCB 106

Ordering number: 132B0368 for J1-J7

VLT® 24V DC Supply MCB 107

Ordering number: 130B1208 for J8,J9

Terminal Cover for drive with MCB option

Ordering number:

132B0263: J1

132B0265: J2

132B0266: J3

132B0267: J4

132B0268: J5

Other accessories

Decoupling Plate Mounting kit

Ordering number:

132B0258: J1

132B0259: J2 & J3

132B0260: J4 & J5

132B0284: J6

132B0285: J7

IP21/Type 1 conversion kit

132B0376: J6

132B0377: J7

Power options

VLT® Sine-Wave Filter MCC 101

VLT® dU/dt Filter MCC 102 1]

VLT® Brake Resistors MCE 101

¹⁾ Note: MCC 102 is for 11 kW and above.

VLT® Encoder Input MCB 102

A universal option for connection of encoder feedback from either a motor or a process.

Encoder module supports:

- Incremental encoders
- SinCos encoders as HIPERFACE®
- SSI encoders
- Power supply for encoders
- RS422 interface
- Connection to all standard 5 V incremental encoders

VLT® Resolver Input MCB 103

Supports resolver feedback for motors.

- Primary Voltage: 2-8 Vrms
- Primary Frequency: 2.0 kHz – 15 kHz
- Primary current max: 50 mA rms
- Secondary input voltage: 4 Vrms

VLT® Sensor Input MCB 114

- Sensor input for temperature transmitters PT100 and PT1000 for monitoring bearing temperatures.
- With one extra current analog input (0/4-20 mA)

VLT® Control Panel LCP 21

This numerical control panel is an easy user interface for the drive.

- Status messages
- Quick menu for easy commissioning
- Parameter setting and adjusting
- Hand-operated start/stop function or Automatic mode select
- Reset function

VLT® Control Panel LCP 23

A graphic control panel for easy use.

- Easily installed
- Available in English, Chinese, and Portuguese
- Multi-line display
- Support setups and parameter copy
- Reset function
- Cabinet-mounting kit available

VLT® Brake Resistors MCE 101

Energy generated during braking is absorbed by the resistors, protecting electrical components from heating up. Danfoss brake resistors are optimized for the FC series. General versions for horizontal and vertical applications are also available.

- Enclosure protection as IP20 and up to IP65
- Built-in thermo switch
- Versions for vertical and horizontal mounting
- UL recognized – only types for vertical mounting

VLT® 24 V DC Supply MCB 106

VLT® 24 V DC Supply MCB 107

Connect an external DC supply to keep the control section and any installed option functioning during power failure.

This enables full operation of the LCP (including the parameter setting) and all installed options without connection to mains.

Compatibility:

- For enclosures in the range J1-J7, use MCB 106
- For enclosures in the range J8-J9, use MCB 107

Input voltage range24 V DC +/-15%
 (max. 37 V for 10 sec.)
 Max. input current.....2.2 A
 Max. cable length.....75 m
 Input capacitance load< 10 uF
 Power up delay< 0.6 s



VLT® Control Panel LCP 21

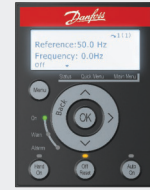

VLT® Control Panel LCP 23



VLT® Encoder Input MCB 102,
 VLT® Resolver Input MCB 103 and
 VLT® Sensor Input MCB 114

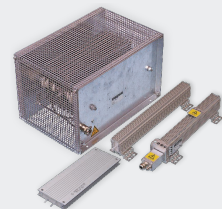

VLT® Brake Resistors MCE 101



VLT® 24 V DC Supply MCB 106



VLT® 24 V DC Supply MCB 107



High dynamic application features

- Integrated motion control features for high dynamic applications
- High performance of speed, positioning, and torque control
- Advanced control algorithm-Flux Basic control with closed loop
- Support various asynchronous and permanent magnet motors
- Mitigating solutions for grid turbulence or power loss situations
- Automatic motor adaption (AMA) to pair the drive and motor automatically
- Embedded application macro features for various applications
- Built-in DC choke to reduce the harmonics distortion

Any information, including, but not limited to information on selection of product, its application or use, product design, weight, dimensions, capacity or any other technical data in product manuals, catalogues descriptions, advertisements, etc. and whether made available in writing, orally, electronically, online or via download, shall be considered informative, and is only binding if and to the extent, explicit reference is made in a quotation or order confirmation. Danfoss cannot accept any responsibility for possible errors in catalogues, brochures, videos and other material. Danfoss reserves the right to alter its products without notice. This also applies to products ordered but not delivered provided that such alterations can be made without changes to form, fit or function of the product. All trademarks in this material are property of Danfoss A/S or Danfoss group companies. Danfoss and the Danfoss logo are trademarks of Danfoss A/S. All rights reserved.

EtherNet/IP™ and DeviceNet™ are trademarks of ODVA, Inc.

Danfoss Drives A/S
Ulsnaes 1
6300 Graasten
Denmark
CVR reg. no. 19883876

© Danfoss 2026-04