

Asphalt

Ice & Snow Melting

Application guide

DEVI[®] 
by Danfoss

Make it easy,
make it **DEVI**



Table of contents

1. Application Overview	4
2. System description	5
3. System design	6
3.1 Heat loss calculation	6
3.2 System output	6
3.2.1 C-C distance and corresponding output (W/m ²)	7
3.3 Recommended Asphalt constructions	8
3.3.1 Mastic asphalt application	8
3.3.2 Road/concrete asphalt application	9
3.3.3 Application with thermal protection layer	9
3.3.4 Insulation	9
3.4 Installation method for asphalt applications	10
4. Product selection	11
4.1 Heating elements	11
4.2 Control	12
4.3 Fixing elements	13
5. Installation process	14
5.1 Planning the installation	14
5.2 Installation process	14
5.2.1 Preparing the installation area	14
5.2.2 Installing heating elements	14
5.2.3 Installation summary	15
5.3 Precautions	16
5.4 Ground sensor installation	17
6. Safety instruction	18
6.1 General safety instructions	18
6.2 DO's	19
6.3 DON'Ts	19
7. Cases	20
8. Technical support	22



Our quality management system **certifications and compliances**

✓ ISO 9001

✓ TS 16949

✓ ISO 14001

Along with full compliance with EU directives and product approvals

Let DEVI do the work

DEVI - an abbreviation of Dansk El-Varme Industri - was established in Copenhagen, Denmark, in 1942. As from January 1st 2003 DEVI has become a part of the Danfoss Group - Denmark's largest industrial Group. Danfoss is one of the world's leading companies within heating, cooling and air-conditioning. The Danfoss Group has more than 23000 employees and serves customers in more than 100 countries.

DEVI is Europe's leading brand of electrical cable heating systems and electric pipe heating systems with over 80 years of experience. The production of heating cables takes place in France and Poland while the head office is situated in Denmark.

The value of experience

We have installed literally thousands of systems across the globe, in every conceivable setting. This experience means that we can offer you practical advice about precisely which components you need to get the best results at the lowest cost.

Asphalt application

This design guide presents DEVI's recommendations for design and installation of ice and snow melting systems for asphalt application. It provides guidance for heating cable positioning, electrical data and system configurations.

Following DEVI's recommendations will ensure energy efficient, reliable and maintenance free solution for constant wattage heating cables with 20 year warranty.

1. Application Overview

Winter weather costs

In recent years there have been plenty of new stories about human and financial costs caused by increasingly harsh winter weather. Property damage, increased maintenance expenses, lost productivity, rising insurance premiums, personal injuries and even worse. Installation of DEVI Ice & Snow Melting System ensures a steady solution to address cold weather related problems.

Asphalt Ground solution – with a first class product range

The DEVIasphalt™ Snow Melting System is a system installed directly in asphalt ensuring instantaneous relief from snow build up and ice forming.



DEVIasphalt™ series introduces completely new standards for high-performance cables used for ice and snow melting in asphalt areas outside.

DEVI recommends the DEVIasphalt™ cables and mats for asphalt installations as they provide short-term resistance to temperatures of 240 °C. With this type of cables and mats the sand bed over the cable is not required. This reduces time and installation costs.

Benefits

- **Efficient snow removal**
- **Safe traffic and working areas** for people
- Quick **installation directly in asphalt**, no need to cover cables with a sand bed or concrete
- Up to **20% Energy saving** comparing to heating elements installation in a sand bed
- **Cost saving** for asphalt repair after winter
- **Environment is protected** against salting and antifreeze related damages.
- Automatic **“Around the Clock”** snow clearing service.
- Smart 2-zone control with **low energy consumption**
- **PVC free**, twin conductors heating cables and mats (IEC 60800 and IEC 62395)
- A maintenance free system with **20 year full warranty** on cables and heating

To avoid cable damage heavy machinery (rollers or asphalt laying machines) should not be used. Asphalt cover should be at least 5 cm thick from the top of the DEVIasphalt™ heating cables. An electrician should ensure of cable and insulation resistance measurements both before and after asphalt is applied.

By using DEVIasphalt™ heating cables and mats controlled by electronic thermostats with moisture sensors, you can cost-

effectively protect large areas such as parking areas, ramps or pedestrian accesses to buildings. Giving you convenience and safety while saving a lot of tiring and time-consuming manual work.

One of the greatest advantages of this system is a prompt response and as a result, the most energy efficient solution for the ground ice & snow melting applications.

2. System description

The most common DEVI ice and snow melting applications on ground are car parks, driveways, pavements, outdoor steps, loading platforms and bridges.

Main purpose of the application is to melt snow or slippery ice on asphalt surfaces.

Like for any other outdoor areas during winter, snow and ice needs to be removed from asphalt surfaces to secure safe access to buildings. It can be done manually or in a smart way – by means of electrical ice & snow melting system with thermostat control and moisture and temperature sensors that can control 2 zones simultaneously. Inactive during cold but dry weather 2 zone control saves energy and reduces costs.

The automatic regulation of the snow melting system keeps areas free of snow and passable at all times – night and day.

Another great advantage of the system installed directly in asphalt is a prompt response or warm up time compared to other installations.

Two types of asphalt applications are used most frequently: Mastic asphalt and Road/concrete asphalt.

Important: if DEVLasphalt™ cable or mat is embedded in asphalt

- 2 layers of asphalt must be always ensured
- DEVLasphalt™ cable must be installed in the first asphalt layer (max. 8 mm stone fraction)
- If road asphalt is used, first layer must be rolled by a hand drum
- First layer must be cooled down to max 80 °C before laying the second layer

- The second layer can be rolled with up to 500 kg

When installing ice and snow melting systems on steep slopes it may be necessary to provide some drainage for melted water at the slope bottom. The drain system should also be protected against ice formations.

The diagram below shows the warm-up time values for 2 different driveways constructions. The heating cable that is installed directly into asphalt (red line) can warm up the surface approx. 4 times quicker comparing to the cable that is installed in sand bed with pavement blocks (blue line).

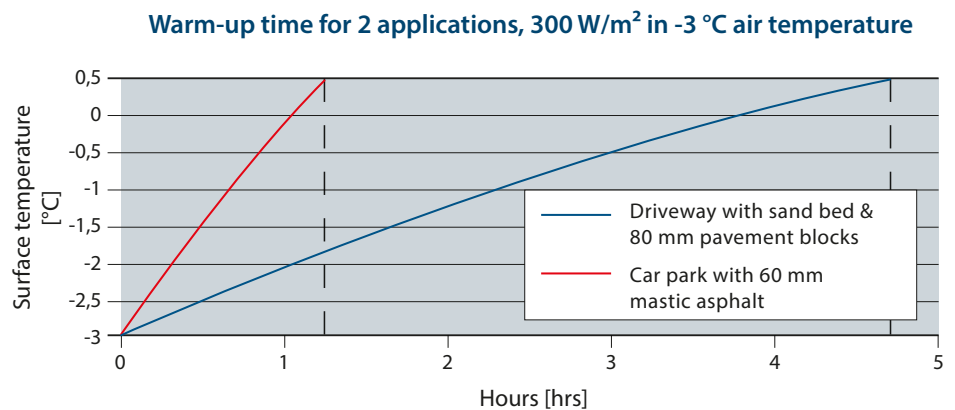

Fig. 1. DEVLasphalt™ heating cable under the first layer of Road asphalt rolled by a hand drum

3. System design

The following paragraphs contain estimations according to ASHRAE, Application Handbook and Historical Weather Data.

Figures are for reference only and can vary depending on the area size, wind speed and ground construction.

Installed output (in W/m^2) for asphalt areas is identical to other ice & snow melting installations. For more information about performance of ice and snow melting systems, as well as control, see Outdoor Application manuals.

When installing ice and snow melting systems it may be necessary to provide drainage for melted water at the slope bottom, walkways, etc. The drain system should also be protected against ice formations.

3.1 Heat loss calculation

The heat required for snow melting depends on the following main factors:

- Weather data (min temperature, max. snowfall rate, wind speed, humidity, altitude);
- Project details (materials, foundation type, dimensions, insulation);
- Electrical data (voltage, power, control requirements);
- System performance expectations;
- Safety factor.

Evaluation of the specific output for ice and snow melting systems can be done based on the diagram and other similar documents.

For example, heat loss depending on the wind speed and temperature differences between the surface and the ambient air is described in 2003 ASHRAE Application Handbook (see fig. 2).

No back loss & area width 6 m & 50% cloud cover
Surface temp. - 3 °C & 70% relative humidity

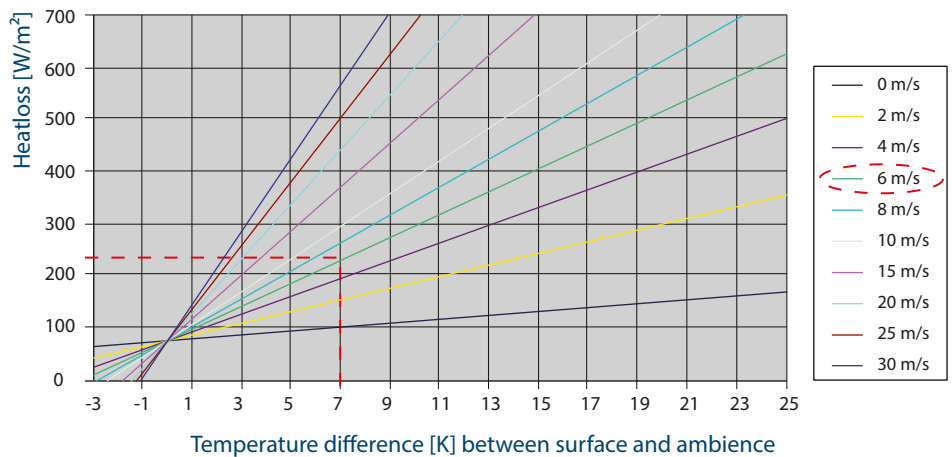

Fig. 2. Wind and temperature dependent heat loss

For example, for medium weather conditions and 6 m/s wind speed, if choosing $\Delta T = 10$ K (from -3 K to +7 K) the heat loss value is approx. $230 \text{ W}/\text{m}^2$ (marked with the red dotted line in fig. 3).

In other words, surface heating up to 10 degrees requires $230 \text{ W}/\text{m}^2$ or $230 / 10 = 23 \text{ W}/(\text{m}^2 \cdot \text{K})$.

All in all, for medium winter weather conditions, heating of 1 m^2 outdoor surface up to 1°C needs power of approx. 23 Watts. Or the calculation heat exchange coefficient for outdoor surfaces is approx. $23 \text{ W}/(\text{m}^2 \cdot \text{K})$ (sometimes named α_{out} – “alpha out”).

3.2 System output

For ice and snow melting systems should be recommended next outputs:

- minimum– $250 \text{ W}/\text{m}^2$,
- optimum – $350 \text{ W}/\text{m}^2$.

Output for ice and snow melting

systems should be designed to follow the local norms and regulations.

Add 100 W/m²:

- for every 1000 m altitude;
- if the heated area is a free standing construction without insulation;
- if the local average wind speed is >6 m/s;
- if the more efficient system is required;
- if it snows at temperatures lower than -10 °C.

Minimum melting temperature

The main task of ice and snow melting systems is melting, i.e. to maintain +3 °C on the surface. Any output can be addressed to the lowest temperature at which ice or snow is still melting and a heating system provides its main task. Table 2 shows some heat output (W/m²) and temperature values at which the system ensures ice & snow melting or, in other words, provides constant +3 °C on the surface.

The recommended heat density values depend on the local climatic conditions and are shown in a table below.

Design temperature, °C	City, e.g.	Recommended specific output, W/m ²	Surface temperature, °C
-5	London	250	11
-15	Vienna, Beijing	350	15
-25	Oslo, Kyiv	400	17
-35	Helsinki	500	21

Note. It is recommended to design output for ice and snow melting systems with maximum possible level.

Specific output, W/m ²	Min air temperature for +3 °C on surface ($\alpha_{out} = 23 \text{ W}/(\text{m}^2 \cdot \text{K})$)
250	-8 °C
300	-10 °C
350	-12 °C
400	-14 °C
550	-21 °C

Table 2. Minimum melting air temperatures for some outputs. ΔT surface-air is calculated as output divided by the heat exchange coefficient 23 W/(m²·K).

For example, if 250 W/m² is installed, then the heating system enables ice and snow melting at the air temperature not lower than -8 °C ($\Delta T = 250/23 \approx 11 \text{ °C}$).

But if the ambient/air temperature is -12 °C for instance, then the surface temperature will be -1 °C, with $\Delta T = -11 \text{ °C}$ for output of 250 W/m². It means that the system consumes power to heat the surface, but doesn't melt ice or snow at all.

3.2.1 C-C distance and corresponding output (W/m²)

The C-C distance is the centre-to-centre distance between the adjacent cables (sometimes named "installation step").

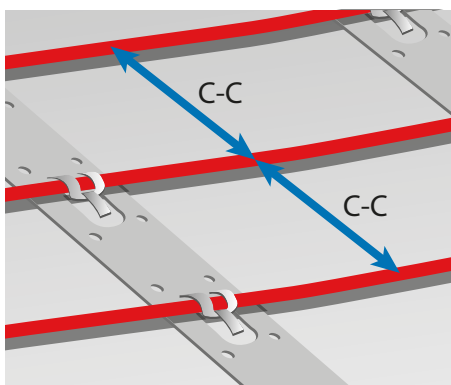

Note! Heating cable bending diameter must be at least 6 times cable diameter.

The C-C distance and corresponding output W/m² can be calculated by the following formulas (see also Application manual - Cable Floor Heating Systems):

$$C - C [\text{cm}] = \frac{\text{Area} [\text{m}^2]}{\text{Cable length} [\text{m}]} \cdot 100 \text{ cm}$$

or

$$C - C [\text{cm}] = \frac{\text{Cable output} [\text{W/m}]}{\text{Heat density} [\text{W/m}^2]} \cdot 100 \text{ cm}$$

Output of the DEVlasphalt™ cable for some C-C is presented in table:

C-C distance, cm	Heat density, W/m ² (400 V)
	DEVlasphalt™ 30T
5	600
6	500
7	429
7,5	400
8	375
9	333
10	300



3.3 Recommended Asphalt constructions

3.3.1 Mastic asphalt application

Mastic asphalt is a dense mass composed of suitably graded minerals such as chippings, sand, limestone powder and bitumen. When Mastic asphalt is used along with heating cables, it should be used as a filling material with rounded stones of small fraction (less than Ø8 mm) in such a way as not to damage the heating cables.

Impervious consistency of the Mastic asphalt can be attributed to its high content and concentration of bitumen that is much higher than in Road/concrete asphalt.

When Mastic asphalt is heated to high temperatures, it is formed as a solid liquid substance that can be poured or spread over the

surface by means of a hand float or mechanical finishing.

The primary difference between Mastic asphalt and Road/concrete asphalt is the compound density.

Mastic asphalt provides a perfect impermeable mass. It is often

used in park decks, bridges and tunnels or as a filler.

Mastic asphalt does not need any compaction/compression as contrasted to Road asphalt.

The Mastic asphalt installation temperature shall not exceed 240 °C before pouring over the cables.

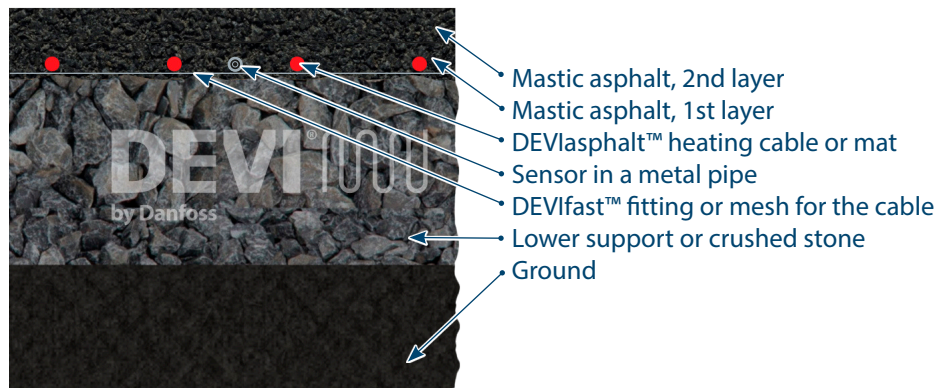

Installation requirements in Mastic Asphalt

Only use DEVIasphalt™ fully embedded. Mastic asphalt shall be cooled down to max. 240 °C

3.3.2 Road/concrete asphalt application

Road/concrete asphalt is typically composed of 5% asphalt/bitumen cement and 95% aggregates (stone, sand, and gravel).

The temperature required when spreading can vary depending upon characteristics of the asphalt or bitumen and is usually 130...150 °C.

Considering sturdiness and ability for quick repair, it is easy to maintain asphalt pavements. Wear or damaged surfaces can be milled, removed and replaced by a new

layer. Road asphalt is often laid in layers with compaction of each by means of mechanical rollers.

First later of road asphalt must be rolled by a hand drum. Second layer may be rolled with up to 500 kg.



- Road asphalt, 2nd layer
- Road asphalt, 1st layer
- DEVlasphalt™ heating cable or mat
- Sensor in a metal pipe
- DEVIfast™ fitting or mesh for the cable
- Lower support or crushed stone
- Ground

Installation requirements in Road/concrete asphalt

First layer – 3 cm hand rolled asphalt concrete (max. 8 mm stone size), (no vibrator).

Apply second layer with a max. 500 kg drum size (no vibrator).

3.3.3 Application with thermal protection layer

Heating cables or mats can be placed in thermal protective layer – sand, concrete, etc. It ensures the heating cable protection against high temperatures of the asphalt cover.

When concrete is used as a protection it is possible to roll asphalt with no weight restriction.

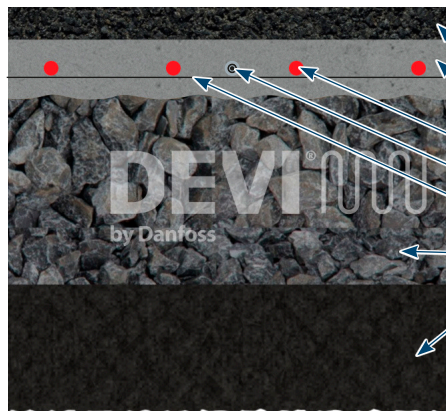

- Asphalt, one or more layers
- Sand/Concrete protection layer
- DEVlasphalt™ heating cable or mat
- Sensor in a plastic conduit pipe
- DEVIfast™ fitting or mesh for the cable
- Lower support or crushed stone
- Ground

3.3.4 Insulation

The benefit of thermal insulation is significant for free standing constructions as ramps or bridges, steps, etc. Insulation of the free sides of the construction must also be considered.

In this example, a 6 m wide bridge is exposed to snow at -3 °C air temperature and 4,5 m/s

crossing wind. Calculated approx. downward heat losses are presented in the table below.

Insulation thickness	Downward heat loss, %
No insulation	36
20 mm	23
50 mm	15
100 mm	9



- Asphalt, one or more layers
- Sand or concrete protection layer
- DEVlasphalt™ heating cable
- Sensor in a plastic conduit pipe
- DEVIfast™ fitting or mesh for the cable
- Insulation
- Free standing construction
- Ambient/air temperature

3.4 Installation method for asphalt applications

Heating Cables embedded direct in Asphalt

Ground areas such as car parks

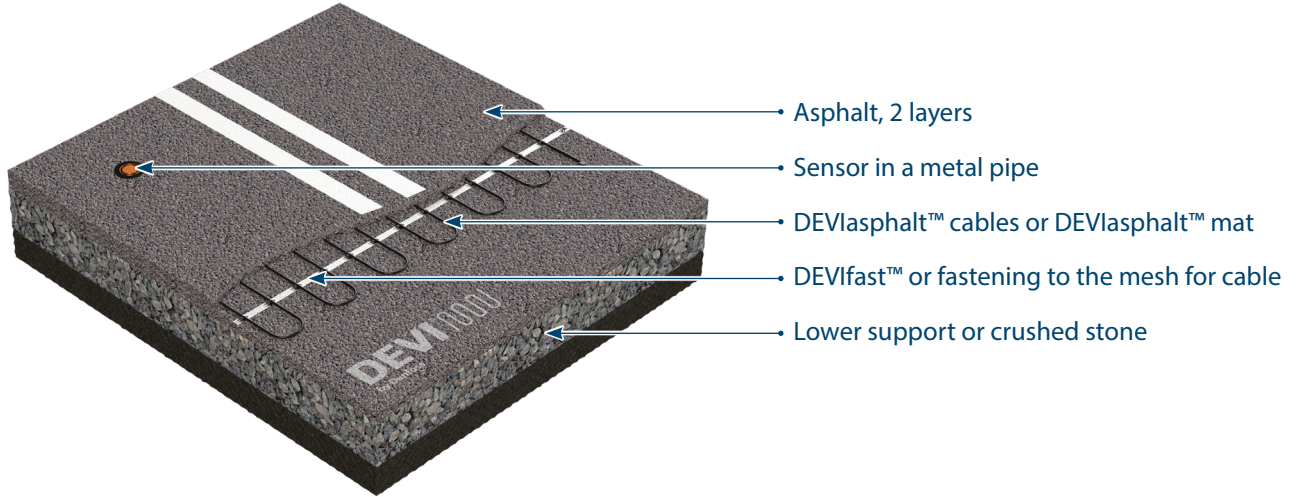

Heating Cables embedded in a protection layer under Asphalt

Ground areas such as driveways, walkways and pavements

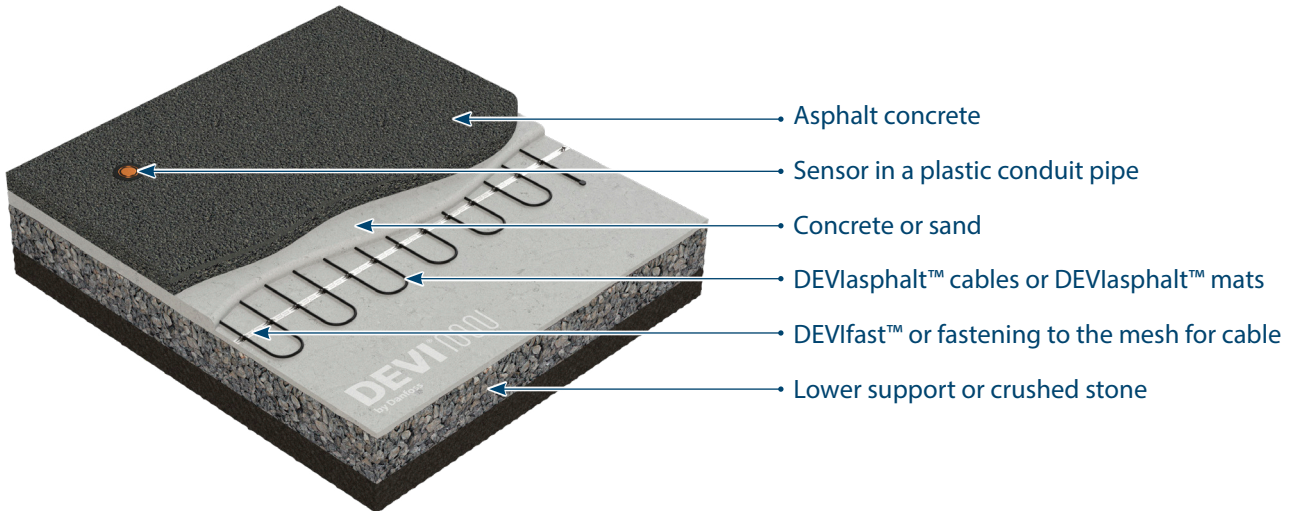

4. Product selection

4.1 Heating elements

For a heating system installed into asphalt following resistive (constant wattage) heating elements can be used:

- DEVlasphalt™ 30T heating cable;
- DEVlasphalt™ 300T heating mat.

DEVI resistive heating elements ensure safe, efficient and economical asphalt application.

DEVlasphalt™ cables and DEVlasphalt™ mats are extremely high-quality products consisted of a 360° fully screened twin conductor cable with highly robust outer sheath (UV stable), designed especially for embedding in mastic asphalt or road/concrete asphalt.

The 10 m cold lead has solid conductors ensuring quick installation with a clearly visible connection.

To ensure long life-time and quality all cables are thoroughly inspected including tests for

Ohmic resistance, high voltage and material control.

DEVlasphalt™ 30T cable is a twin conductor heating cable for installation in asphalt of 240 °C maximum installation temperature. Cables comply with EN62395-1:2006 and IEC 60800:2009 class M2 - for applications with high risk of mechanical damage.

It's supplied in a readymade set with a 10 m cold lead, hermetic connections and end muffs.



Cable diameter – 7 mm.
Cables are available for 400 V power supply.
Cable linear output is 30 W/m (400 V). Available lengths: 8,5 - 215 m.

DEVlasphalt™ 300T mat is a heating mat with DEVlasphalt™ heating cable fixed on a plastic mesh.

Mats are available for two power supply options - 230 and 400 V.

Output is 300 W/m² (230 or 400 V).

Mat width - 0,5 m for 230 V and 0,5, 0,75 and 1 m for 400 V.

Available size: 1 - 12,4 m² for 230 V and 1,7 - 21,15 m² for 400 V.

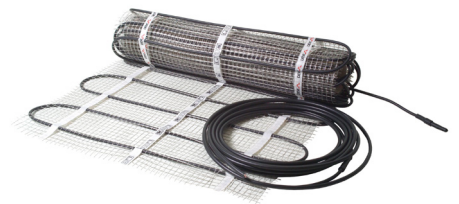

Note. The number at the end of the cable's and mat's name refers to its linear output – W/m or area output – W/m², at 230 V or 400 V. Letter "T" means twin conductor cable (Twin).

Product type	Product name	Description
DEVlasphalt™ Resistive heating cable	DEVlasphalt™ 30T 400 V program	Twin conductor, 100% screen, UV stabilized, black, short term contact with 240 °C allowed, 30 W/m (400 V). DIN IEC 60800:2009 M2, EN 62395-1:2006
DEVlasphalt™ Resistive heating mat	DEVlasphalt™ 300T 230 & 400 V program	Twin conductor, 100% screen, UV stabilized, black, short term contact with 240 °C allowed, 300 W/m ² (230 V/400 V). DIN IEC 60800:2009 M2, EN 62395-1:2006

For additional information please refer to the DEVI Catalogue.



4.2 Control

Ice and snow melting systems are different and require different thermostats/regulators.

DEVireg™ thermostats and regulators are fitted with a complete set of control functions for heating systems for ice and snow melting of any type and allow attaching external measuring sensors for ground temperature measuring as well as control of moisture conditions.

The product range of controls is designed for external systems including the following:

- thermostats with a temperature sensor - DEVireg™ 330 (5...45 °C), DEVireg™ Multi, DEVireg™ 610;
- regulator with an integrated temperature and moisture sensor(s) - DEVireg™ 850.

To control simple or low output systems thermostat with a ground temperature sensor is recommended. **DEVireg™ 330 (5...45 °C)** thermostat with the DIN rail attachment is recommended as a standard

solution. It can be also used on wall/pipe mounted **DEVireg™ 610**, IP44. As an alternative to control small areas near private houses etc.

DEVireg™ Multi is 7 channel electronic programmable controller to be installed on DIN rail.

All thermostats above are supplied with a wire temperature sensor – NTC 15 kOhm @25 °C, 3 m.

To control ice and snow melting systems especially with high output the best solution is DEVireg™ 850 regulator/controller with integrated ground and roof moisture and temperature sensors.

DEVireg™ 850 is a two-zone controller with possibility of connection up to 4 sensors to provide maximum control of the outdoor heating system. Comparing to installations with typical ground temperature measuring this regulator allows reduction of energy consumption costs by up to 30-40%



DEVireg™ 850 with ground sensor



DEVireg™ Multi



DEVireg™ 610



DEVireg™ 330 (5...45 °C) with wire sensor in set

Product type	Product name	Description
DEVIreg™ Regulator	DEVIreg™ 850	Connection to Ground and Roof moisture and temp. sensor, max 4 sensors, 2 zones, 2x15 A, PSU 24 V, DIN rail
Moisture & temperature sensor	Ground sensor for DEVIreg™ 850	Ø93 x 98 mm, IP67, 15 m connection cable 4x1 mm ²
Accessories	PSU 24 V for DEVIreg™ 850	54 x 90 x 55 mm, DINrail, one PSU can be used up to 4 sensors
DEVIreg™ Thermostat	DEVIreg™ Multi	-50...+250C, 7 channel (2 x 10A, 5 x 6A), IP40, with 3 m wire sensor, DIN rail
DEVIreg™ Thermostat	DEVIreg™ 610	-30...+50 °C, 10 A, IP44, with wire sensor, 3 m, on wall/pipe installation
DEVIreg™ Thermostat	DEVIreg™ 330 (5...45 °C)	5...45 °C, 16 A, IP20, with wire sensor, 3 m, DIN rail
Temperature sensor	10 m, PVC	Wire sensor, Ø8 mm, IP65, NTC 15 kOhm @25 °C

For additional information please refer to the DEVI Catalogue.

4.3 Fixing elements

If heating cable is applied, it is recommended to use a fitting band to fix cable to the floor base. For example, metal galvanized DEVIfast™ fitting

band. It is attached to the basement (nailed etc.) in parallel lines usually in 50 cm intervals of fitting band for each square meter of the cable installation.



DEVIfast™

Product type	Product name	Description
Fixing	DEVIfast™ Metal	25 m pack; galvanized metal, fixings every 2,5 cm.

For additional information please refer to the DEVI Catalogue.

5. Installation process

5.1 Planning the installation

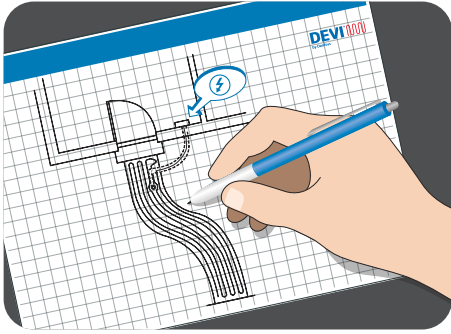

Draw a sketch of the installation showing

- element layout
- cold leads and connections

- junction box/cable well (if applicable)
- sensor
- connection box
- thermostat/regulator

Save the sketch

- Knowing the exact location of these components makes subsequent troubleshooting and repair of faulty elements easier.

Please observe the following:

- Observe all safety guidelines.
- Observe correct cable

C-C distance and distance between mats.

- Observe required installation depth and possible mechanical protection of cold leads according to local regulations.
- When installing more than one heating element, never wire elements in series but route all cold leads in parallel to the connection box.
- For single conductor cables, both cold leads must be connected to the connection box.

5.2 Installation process

5.2.1 Preparing the installation area



Remove all traces of old installations, if applicable.

- Ensure that the installation surface is even, stable, smooth, dry and clean.
- Mastic asphalt shall be cooled down to max. 240 °C.

- If necessary, fill out gaps around pipes, drains and walls.
- There must be no sharp edges, dirt or foreign objects (max. 8 mm stone size).

5.2.2 Installing heating elements

It is not recommended to install heating elements at temperatures below -5 °C.

At low temperatures, heating cables can become rigid. Connect the cable/mat to the mains for a short time (few minutes). The cable or mat must be rolled out during this process!

Measuring resistance

Measure, verify and record element resistance during installation.

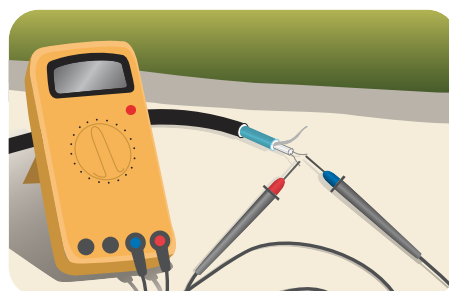

- After unpacking
- After fastening the elements
- After the installation is finalized

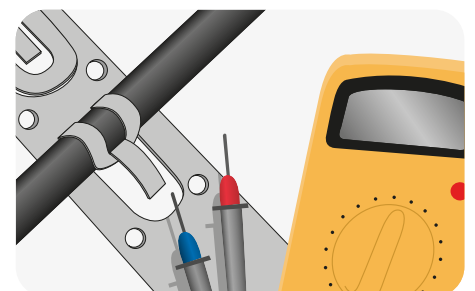

If Ohm resistance and insulation resistance are not as on label attached to product and product transportation box, the element must be replaced.

- The ohmic resistance must be within -5 to +10 % of the value labeled.
- The insulation resistance should read >20 MΩ after one minute at min. 500 V DC.

Observe all instructions and guidelines in section about general safety and in proper installation instructions.

Heating elements

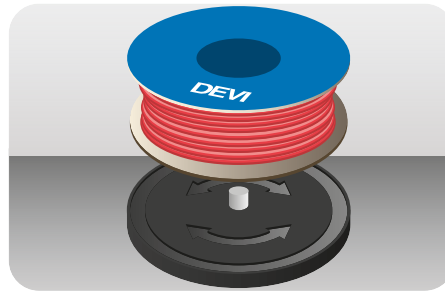

- Position the heating element so that it is at least half the C-C distance from obstacles.
- Heating elements must always be in good contact with the heat distributor (e.g. concrete).
- When using heating mats secure them to the ground, some mats are mitted with a glue covered surface, it attaches well to a cleaned and primed surface.

Heating mats

- Roll out the heating mats with plastic mesh over the heating cables.
- When the heating mat reaches the area boundary, cut the liner/net and turn the mat before rolling it back.

Extending cold leads

- Avoid extending cold leads if possible. Wire cold leads to e.g. junction boxes or cable wells.
- Be aware of power loss in the extending cold leads according to local regulations and wiring rules.

When extending cold lead, observe:

- That there is max. 5% loss of potential power in the whole length of the cold cable.
- That the leak current of the whole installation is less than 1/3 of the RCD trigger level.

5.2.3 Installation summary

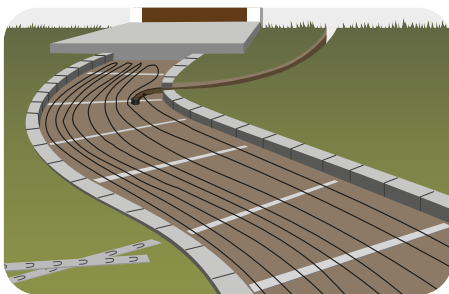

Prepare installation surface with fastening accessories and/or mesh reinforcement.

Apply sensor conduit Ø 16-20 mm made from heat resistant material, e.g. metal. Fix conduit for sensor tube for DEVIreg™ 850 ground sensor, if any.

Place cold leads and connections in a dry place. Seal all penetrations through walls or similar structures. Apply caution tape above cold leads.

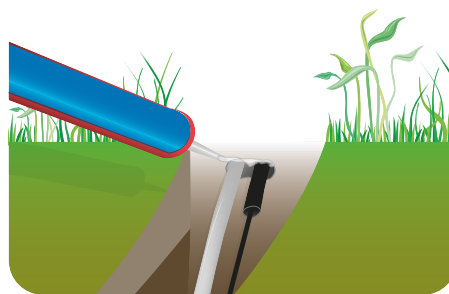

After laying blocks or pouring concrete/asphalt, install external sensor(s), and extend sensor cable(s) according to the sensor manual.

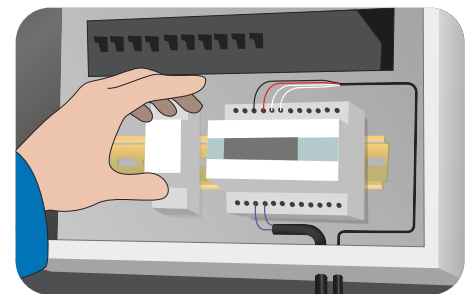

The DEVIreg™ thermostat/regulator must be commissioned as prescribed in the installation manual and adjusted where local conditions vary in relation to factory settings.

Before every season, check for faults in the switchboard, thermostat and sensors.

5.3 Precautions

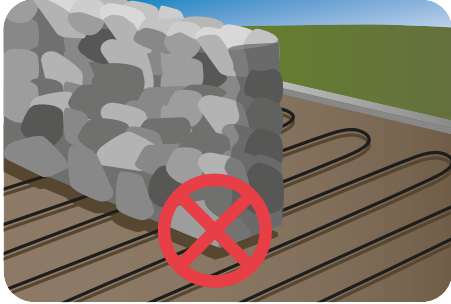

Do not install heating elements under walls and fixed obstacles. Min. 6 cm space is required. Keep elements clear of insulation material, other heating sources and expansion joints.



Heating elements may not touch or cross themselves or other heating elements and must be evenly distributed on areas.



The elements and especially the connection must be protected from stress and strain.



The element should be temperature controlled and not operate at ambient temperature higher than 10 °C in outdoor applications.



Ensure to clean the area properly from stone and sharp edges.



Protect the heating cables against excessive use of rakes, shovels, vibrators and rollers.

Fasten the cables to the sub-construction in short distances to ensure that the cable remains in right position.

It is recommended to connect a buzzer or other alarm giving device to the cables if an incident anyway should occur during installation despite all caution and a cable is being damaged. Then there will be the ability to quickly detect this and get the problem solved at the lowest possible cost and delay.

Ensure that all cables turn towards the electrical cupboards where the cables shall be connected.

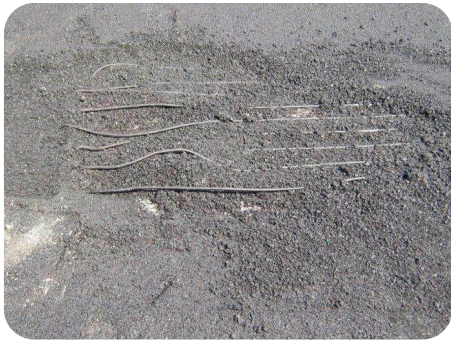

Remember that the cable always shall be fully embedded to avoid air gaps.



It is not allowed to drive directly on the cables with heavy trucks or asphalt machinery. It will immediately lead to cable damages.

5.4 Ground sensor installation

Installing ground sensors

At this point you must have located the appropriate spots for the ground sensors and extended the feeder cable if necessary.

The sensor part and the sensor tube may now be installed in connection with the actual construction work and connected at a later date. The following applies for all types of installations.

- The base below the sensor tube must be hard, e.g. a concrete plate or similar, in order to ensure that the sensor is not pushed into the ground if e.g. a lorry runs over it. The tube is designed to be mounted on a plate using the two screw holes inside the tube.
- Place the sensor tube in between the heating cables with a minimum distance of 1 cm.
- The sensor tube must be positioned so that it is flush with the surrounding terrain

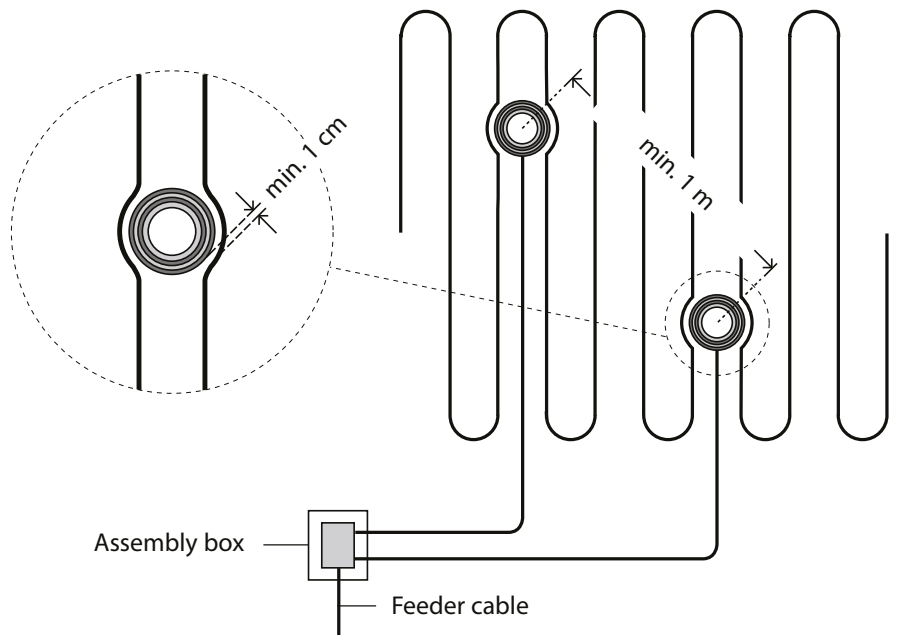

and so that the sensor part must be placed so that the upper brass surface is horizontal.

- Lay a conduit for the sensor cable between the sensor tube and the Devireg 850 controller.

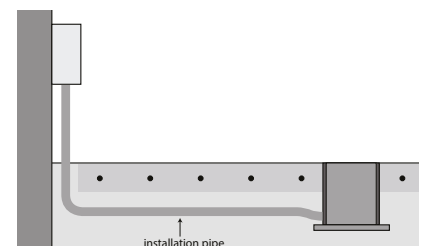
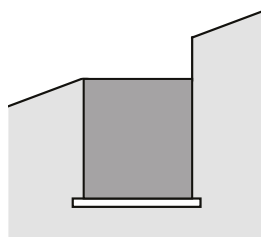

6. Safety instruction

6.1 General safety instructions

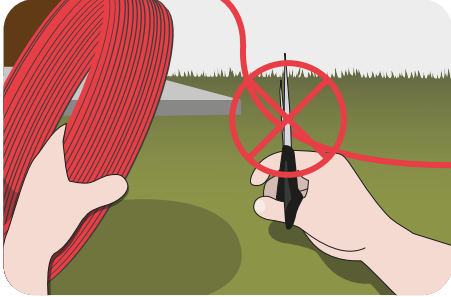

Never cut or shorten the heating element.

- Cutting the heating element will void the warranty.
- Cold leads can be shortened to suit requirements.

Elements must always be installed according to local building regulations and wiring rules as well as the guidelines in proper installation instructions and this manual.

- Any other installation may hamper element functionality or constitute a safety risk, and will void the warranty.
- Make sure that elements, cold leads, connection boxes, and other electrical components do not come into contact with chemicals or flammable materials during or after installation.

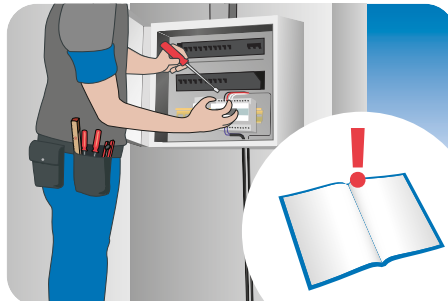

Elements must always be connected by an authorized electrician using a fixed connection.

- De-energize all power circuits before installation and service.
- The connection to the power source must not be directly accessible to the end user.
- Each heating cable screen must be earthed in accordance with local electricity regulations and connected to a residual current device (RCD).
- Recommended RCD trip rating is 30 mA, but may be up to 300 mA where capacitive leakage may lead to nuisance tripping.
- Heating elements must be connected via a switch providing all pole disconnection.

- The element must be equipped with a correctly sized fuse or circuit breaker, e.g. 10/13 A for a 1,5 mm² cold lead and 16/20 A for a 2,5 mm² cold lead.

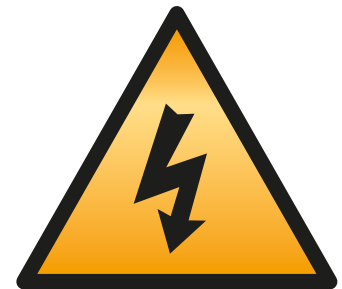

The presence of a heating element must

- be made evident by affixing caution signs or markings at the power connection fittings and/or frequently along the circuit line where clearly visible
- be stated in any electrical documentation following the installation.

Never exceed the maximum heat density (W/m² or W/m) for the actual application.

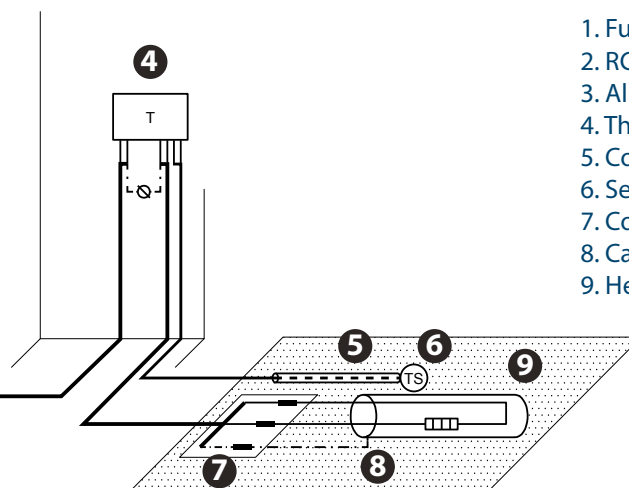
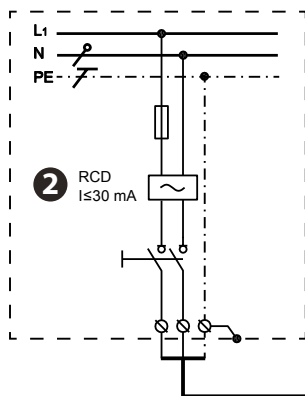

1. Fuse
2. RCD
3. All-pole switch
4. Thermostat
5. Conduit pipe
6. Sensor
7. Connection muff
8. Cable screen
9. Heating cable

6.2 DO's

- Thermostat controlling ground temperature is mandatory.
- For installation of cable and thermostat/controller, always refer to the local regulations/ legislations and respective manuals;
- Remember to fill out the warranty certificate with the required information as this will not be valid otherwise;
- Carefully complete the installation, the cable can break when overloaded;
- If any doubt arises consult you manual or local DEVI department;
- Ensure that the cable is sufficiently fixed and mounted according to the manual;
- Ensure that warning labels and stickers (potentially tape) with warning text is used to inform about the heat traced cable;
- Install sensors where the temperature is estimated to be representative for the whole installation, where 2 sensors are needed for the thermostat/controller please install at the estimated extreme points (coldest and hottest);
- To get the best performance of the system and avoid failures it is necessary to follow the installation descriptions;
- To get the best performance of the system it is strictly necessary to calculate the correct heat losses. Using this knowledge the cable with right output can be chosen;
- Plan every installation step and fixing point of the frost protection system ahead of time and ensure that the "run" is proper and possible;
- Ensure sensors are connected according to the applicable installation guide and/or application guide.

6.3 DON'Ts

- Heating elements may not touch or cross themselves or other heating elements and must be evenly distributed on areas.
- **Never cut or shorten the heating element.**
- Do not wind excess cable onto itself at the end of a run, as this can cause overheating and may damage the cable. Instead, distribute the excess cable evenly within the adjacent area (secondary loop/section).
- Never make an installation without thermostat/ controller;
- Never install cables where the heat can't be dissipated, even with a self-limiting cable the output will never become zero and the cable can overheat;
- Never let unauthorized personnel install controllers/ thermostats or heating elements;
- Never use unauthorized accessories;
- Never use our products (cables, controllers, sensors, etc.) outside provided temperature range.

7. Cases

Warsaw's Municipal Solid Waste Disposal Plant, Warsaw, Poland

To withstand heavy loads, cables were embedded in grooves within the asphalt, ensuring durability and efficiency.

This remarkable facility will process over 300,000 tons of waste annually, generate energy for Warsaw, and boasts unique features like a garbage truck overpass and a 20,000m² public green roof!

Heating area:

750m²

Output power:

400W/m² (300kW total)

Products:

Cables: DEVlasphalt™ 30T/400V

Control: DEVIreg™ 850 +
4 ground sensors



Porsche Centre, Mannheim, Germany

The newly constructed building and workshop extension at the Porsche Centre in Mannheim has resulted in one of Germany's largest and most advanced service facilities for sports cars.

A standout feature of this state-of-the-art facility is the DEVI asphalt ramp heating system. This innovative solution ensures safe use of the ramps throughout the winter months by keeping them free from ice and snow. With DEVI asphalt heating in place, both vehicles and employees benefit from significantly improved safety and reliability.

The 75 cm wide heating mats were installed across six continuous lanes for ascent and descent with a DV 17-20 control distribution unit for efficient power management. The heating system is controlled by DEVIreg[™] 850 with two sensors for precise temperature control and monitoring.

Heating area:
330 m²

Output power:
300W/m² (109 kW total)

Products:

Mats: DEVIasphalt[™] 300T/400V

Control: DEVIreg[™] 850 +
ground sensors

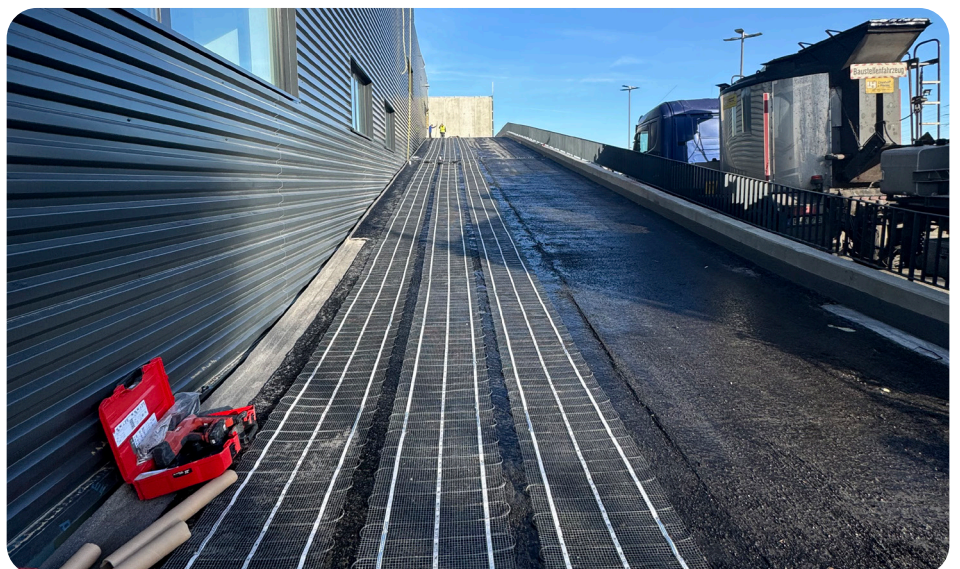

8. Technical support

The Electric Heating team supports professionals with reliable expertise and proven solutions.

We offer:

- Precise calculation and design of electric heating systems
- Development of project drawings
- Preparation of a complete Bill of Materials (BoM)
- Practical recommendations for installation and system operation
- Professional technical training

With our experience, you can be confident in efficient, safe, and long-lasting electric heating solutions.

In order to clarify the project data for different applications use the following technical request forms, fill in with your specifications and send it to:

EH@danfoss.com

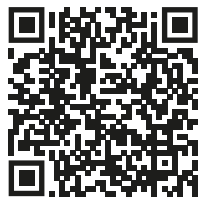

<https://devi.com/en/service-and-support/global-technical-support>



Make it easy,
make it DEVI



Follow our global channels



140F9002 & AB208886468851en-010301 | 01.05.2026



Make it easy,
make it DEVI

Danfoss A/S

DEVI • devicom • +45 7488 2222 • EH@danfoss.com

Any information, including, but not limited to information on selection of product, its application or use, product design, weight, dimensions, capacity or any other technical data in product manuals, catalogues descriptions, advertisements, etc. and whether made available in writing, orally, electronically, online or via download, shall be considered informative, and is only binding if and to the extent, explicit reference is made in a quotation or order confirmation. Danfoss cannot accept any responsibility for possible errors in catalogues, brochures, videos and other material. Danfoss reserves the right to alter its products without notice. This also applies to products ordered but not delivered provided that such alterations can be made without changes to form, fit or function of the product.

All trademarks in this material are property of Danfoss A/S or Danfoss group companies. Danfoss and the Danfoss logo are trademarks of Danfoss A/S. All rights reserved.

devi.com