

# Joysticks

## JS1 Heavy Duty Joysticks



## Revision history

*Table of revisions*

Date	Changed	Rev
April 2026	Updated drawings	1601
March 2024	Updated Mechanical Specifications, Joystick Functions Product configuration model codes	1501
May 2023	Added Analog Function for 18-pin connector, new FNR joystick function	1401
October 2020	Corrected some information in tables and removed discontinued product line	1305
July 2020	Changed document number from 'BC00000347' to 'BC171886484518' and added cable model code option W	1304
June 2019	Updated for PWM	1201
November 2018	Moved PR2, PP2 grip cover option H8-Y and put in circle and lowered; Added note to top of Electronic modules chapter; Updated JS1-H Analog Category 1 and 3 wiring connection diagrams; Changed FNR IP to IP 66; Under Mechanical, changed table Friction hold/Spring return, base only, row 1 code to E and row 2 code to J; JS1-H Base model code Table C, added row PEP; Table D, Changed row 1 code to E and row 2 code to J that applies only when using XF base; added sub-topic JS1 Heavy Duty Joystick critical mounting under topic Joystick safety critical functions	1101
August 2018	Updated for spring/friction base	1001
June 2018	Changed vertical maximum load; Added table under Joystick Functions for Operator Presence Switch (PR7, PPR grip only); Added A and E options for Operator Presence Switch, in last two rows of table H8-Defining grip side, under chapter Product configuration model code.	0901
March 2018	Removed J options from PR7, PP7 grip faceplate options; Added Grip only sales and service options topic; removed the wire color column from all connectors pin tables; corrected H4 through H12 tables under Grip model code; added to types of grips offered for applications that require high ingress protection; and listed grips with Operator Presence Switch in Product configuration model code table H7 and H8	0801
January 2018	Added Analog Cat 1, 3 information	0701
November 2017	Added CANalog and CAN+ information	0601
January 2017	Pushbutton color codes updated	0503
January 2017	Removed information that does not apply, corrected PR2 grip options information	0502
December 2016	Added PVE information	0501
October 2016	Updated PR2 faceplate designation; and Environmental IP rating	0403
September 2016	Updated Operating temperature for CAN to 85° C in Environmental table	0402
September 2016	Updates regarding IP switches; Common model code for J3-cable	0401
September 2016	Various updates; updated to Engineering Tomorrow design	0302
February 2016	Removed Connection diagrams chapter	0201
February 2016	First edition	0101

**Overview**

JS1-H description.....5  
 Features.....5  
 Options.....6

**HR1, HP1 grip**

Description.....7  
 Dimensions.....8  
 Ten total grip functions.....8  
 Function overview.....9  
 Faceplate options.....9  
 Cover options.....10  
 Base options.....11

**ST2, SP2 grip**

Dimensions.....13  
 Five total grip functions.....13  
 ST2—Faceplate options.....14  
 Cover options.....14

**PR2, PP2 grip**

Dimensions.....16  
 Twelve total grip functions.....16  
 Faceplate options.....17  
 Cover options.....18

**ST7, SP7 grip**

Dimensions.....20  
 ST7—Faceplate options.....21  
 Cover options.....22

**PR7, PP7 grip**

Dimensions.....24  
 Faceplate options.....25  
 Cover options.....26

**Compatible grips**

Dimensions.....27  
 Grip and Base only sales and service options.....27

**Base**

Dimensions.....29

**Electronic modules**

CAN.....30  
 CAN+.....30  
 CANalog.....30  
     Additional X and Y analog outputs.....30  
     Proportional roller output.....30  
 PVE.....30  
 PVE—Standard.....31  
 PVE—Extended.....32  
 PVE - Programmable.....32  
 Non-Redundant Analog interface (CAT1).....33  
 Full-Redundant Analog interface (CAT3).....33  
 PWM (Programmable).....33

**Connection diagrams**

CAN+.....34  
 CANalog.....35  
 PVE DSUB.....36  
 Analog Cat 1.....37  
 Analog Cat 3.....38  
 PVE Deutsch.....39  
 PWM.....40

**Specifications**

Mechanical.....	41
Electrical—CAN, CAN+, and CANalog.....	42
Electrical—PVE (Standard and Extended).....	42
Electrical—PVE (Extended only).....	42
Electrical—Analog Cat 1, Cat 3.....	42
Electrical—PWM.....	43
Environmental.....	43

## Joystick functions

Grip options.....	44
Push button.....	45
Roller.....	45
FNR.....	47
Toggle switch.....	48
Operator Presence switch.....	49

## Connector options and cabling

One 6 pin connector.....	50
Two 6 pin connectors.....	51
Two 12 pin connectors.....	52
Two 12 pin and one 6 pin connectors.....	53
One 18 pin connector.....	54
One 25 pin SUB-D and one 6 pin connectors.....	56
Mating connectors bag assemblies.....	57
Cable assemblies.....	58

## Product configuration model code

JS1-H base and grip model code fields.....	60
JS1-H Base model code.....	61
Grip model code.....	63
Other model code.....	71

## Product installation

Joystick safety critical functions.....	72
JS1 Heavy Duty Joystick critical mounting.....	72
Machine wiring guidelines.....	72

## Appendix: CAN J1939 protocol

Joysticks CAN J1939 protocol option.....	75
SAE J1939 basic joystick message.....	76
Data field.....	76
JS1-H Basic joystick message data field descriptions.....	77
Joystick X-axis neutral position status.....	78
Joystick X-axis handle left negative position status.....	78
Joystick X-axis handle right positive position status.....	78
Joystick X-axis position status.....	78
Joystick Y-axis neutral position status.....	78
Joystick Y-axis handle back negative position status.....	79
Joystick Y-axis handle forward positive position status.....	79
Joystick Y-axis position status.....	79
Joystick button 1-8 pressed status.....	79
SAE J1939 extended joystick message.....	81
Extended joystick message parameters and data field descriptions.....	81
SAE J1939 error (DM1) messages.....	82

## Appendix: CAN+ and CANopen protocol

CANopen Object Dictionary for JS1-H joysticks.....	84
Parameter/variable index - JS1-H CAN, JS1-H CANalog.....	85
Parameter/variable index - JS1-H CAN+.....	96
Error handling.....	107

## Overview

### JS1-H description

*A wide variety of new grip designs*



The Danfoss JS1 platform offers a wide variety of new grip designs and were developed after extensive research detailing operator needs. The JS1 heavy duty joysticks (JS1-H) and compatible grips meet the demanding conditions typically found in mobile equipment environments. The available grips features provide a high degree of protection from chemicals, shock, vibration and EMC exposure. Danfoss joysticks are appropriate for both in-cabin and out of cabin applications and feature ergonomic forms that minimize machine operator fatigue. The JS1-H ergonomic left-hand, right-hand and ambidextrous grip design options enable efficient operation and comfortable human-machine interface with easy to use fingertip controls for maximum productivity. The grips feature a modular design that allows switch and proportional rollers locations flexibility.

### Features

- Hall effect with two sensors per axis or long life potentiometer position sensing
- Simultaneous operation of two proportional rollers
- Operator Presence switch

## Options

### Axis

- Dual Axis Spring Return
- Single Axis Spring Return
- Single Axis with Friction
- Dual Axis with one axis Spring, one axis Friction

### Output options

- CAN J1939
- CANopen
- PVE
- CANalog
- CAN+
- Analog Category 1
- Analog Category 3
- PWM (programmable)

### Ergonomic grip

- Right hand
- Left hand
- Ambidextrous (used with either the left or right hand)

### On axis shaft, deflection

- $\pm 18^\circ$

### JS1-H grips

- HR1
- ST2
- ST7
- PR2
- PR7

## HR1, HP1 grip

Horizontal, multifunction, ergonomic HR1, HP1 grip



## Description

The horizontal, multifunction, ergonomic HR1, HP1 grip is designed with easy to use fingertip controls for a comfortable user interface and maximum functional control.

The grip features a modular design that allows flexibility in the location of switches and proportional functions.

For applications that require high ingress protection (IP66) select the HP1 grip. For more information, see ordering code F2, under *Grip model code* on page 63.

## Dimensions

HR1 (horizontal) grip with base dimensions in millimeters [inches]

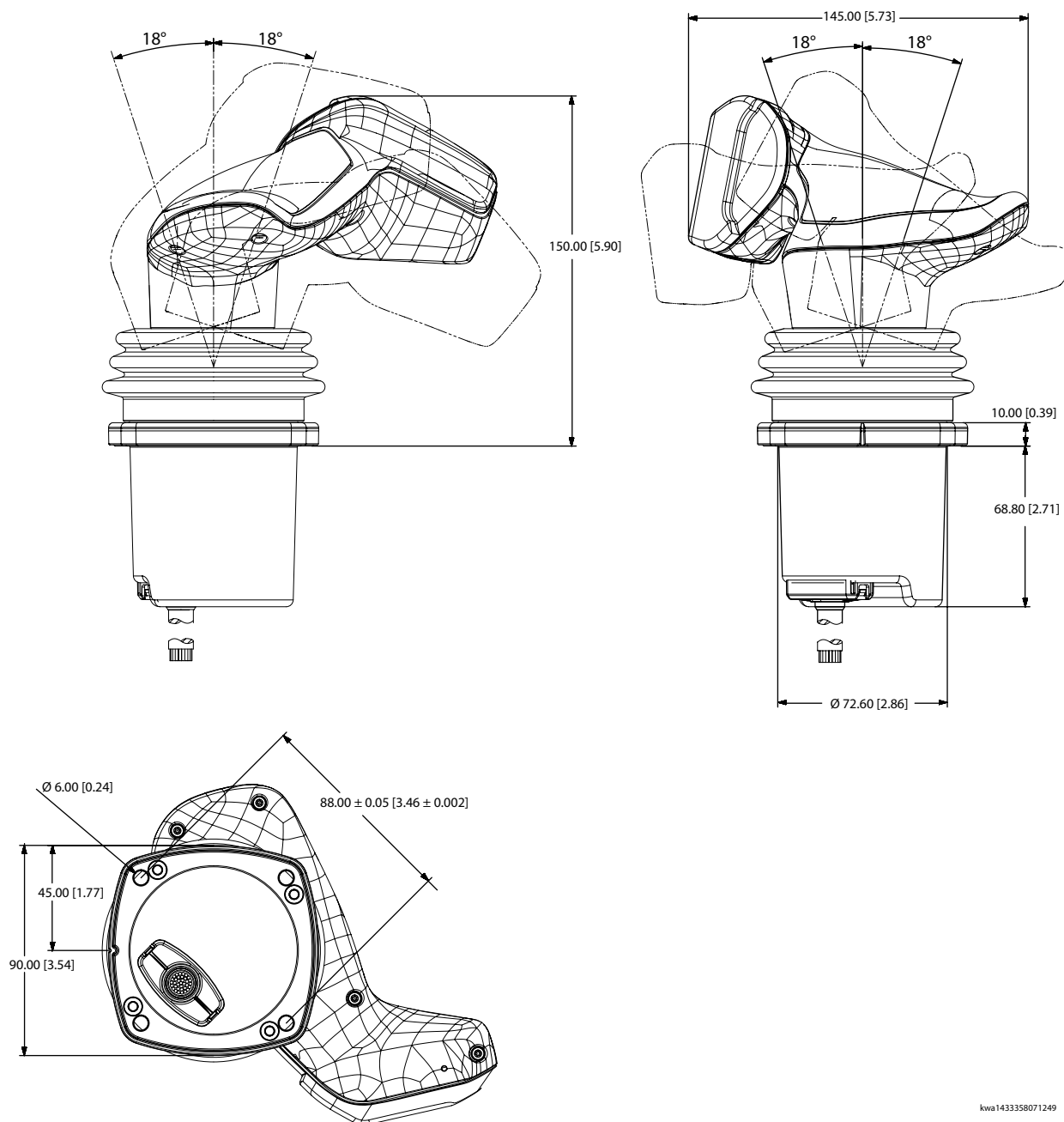

kwa1433358071249

## Ten total grip functions

- Front plate: Up to five functions
- Grip top side: Up to two functions
- Grip rear side: Up to three functions

### Note

Push button = 1 function, roller/rocker/FNR/Operator Presence Switch = 2 functions

## Function overview

### HR1 grip function overview

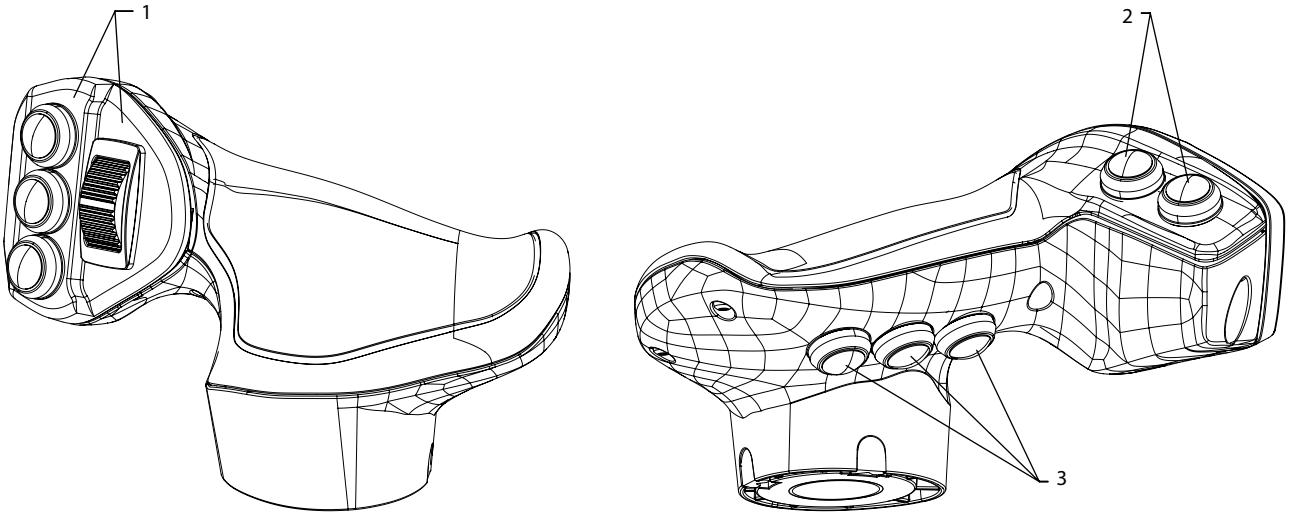

kwa1452624614146

1. Faceplate finger function location
2. Cover finger function location
3. Base finger function location

## Faceplate options

### HR1 grip faceplate options

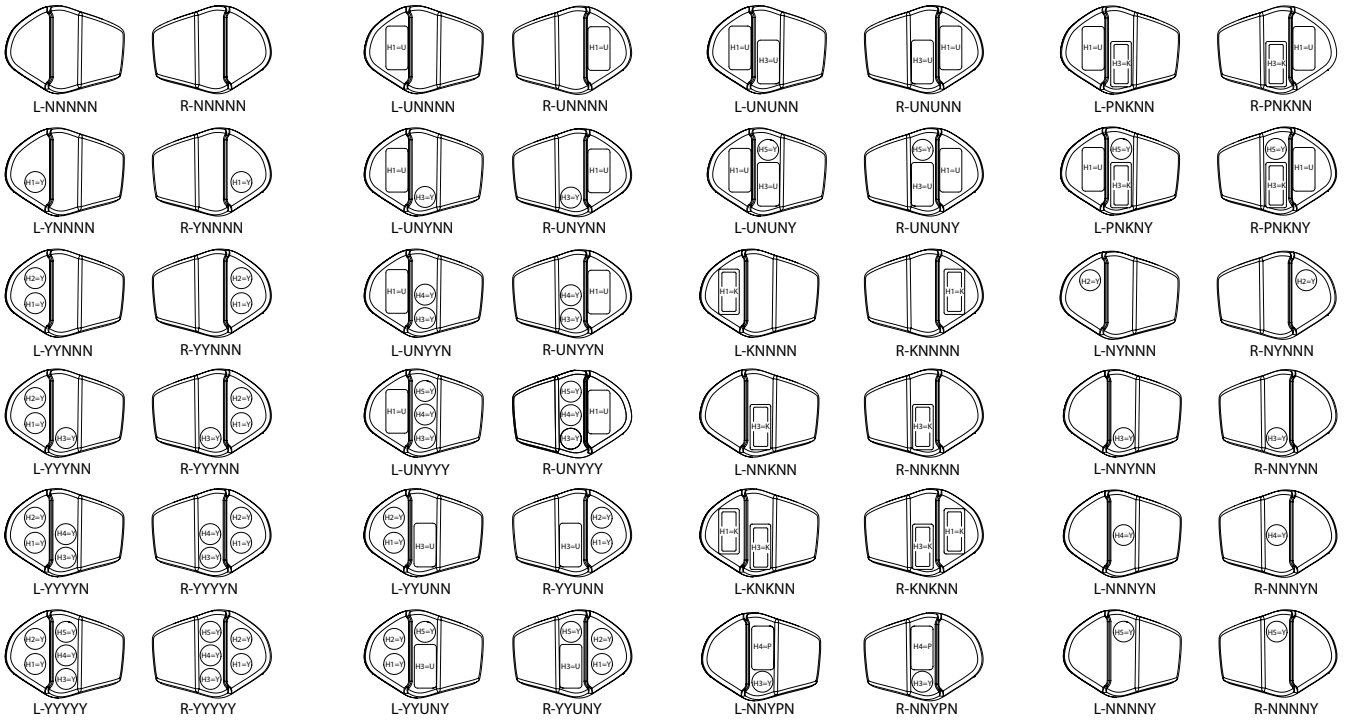

kwa1452624730259

### Related reference

### Cover options

#### HR1 grip cover options

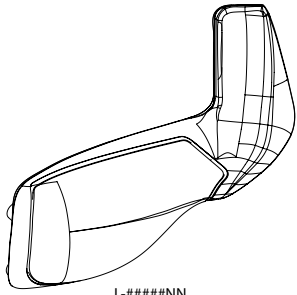

L-####NN

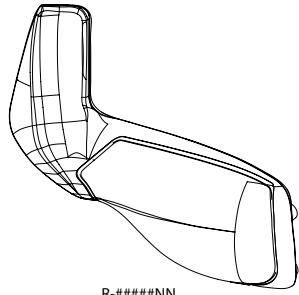

R-####NN

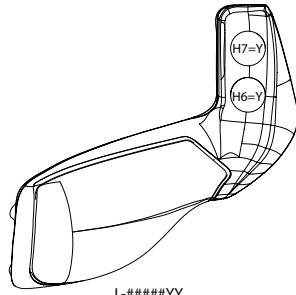

L-####YY

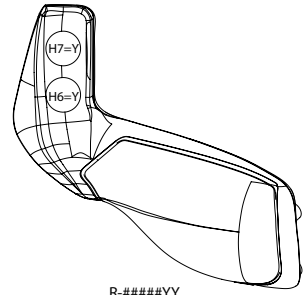

R-####YY

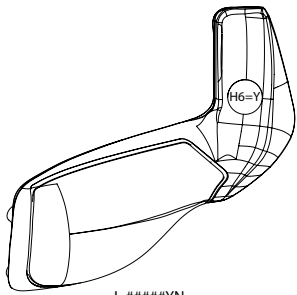

L-####YN

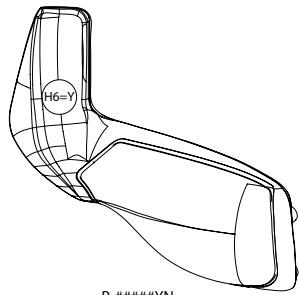

R-####YN

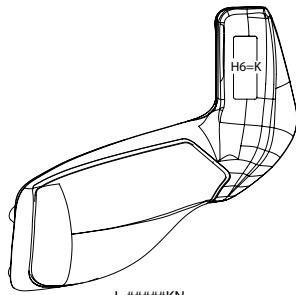

L-####KN

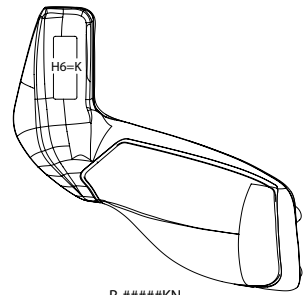

R-####KN

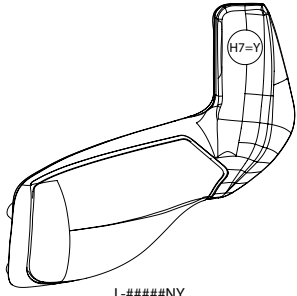

L-####NY

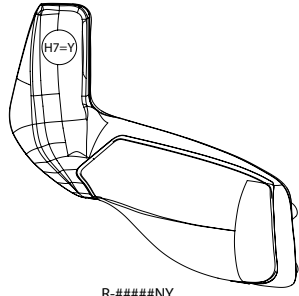

R-####NY

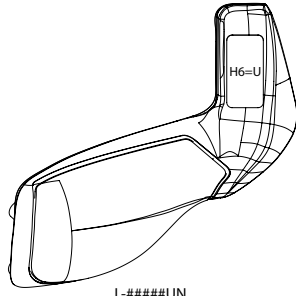

L-####UN

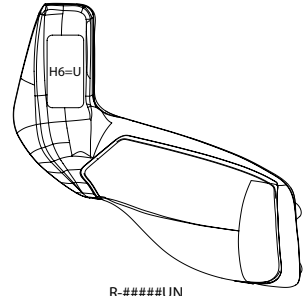

R-####UN

kwa1452624768604

### Base options

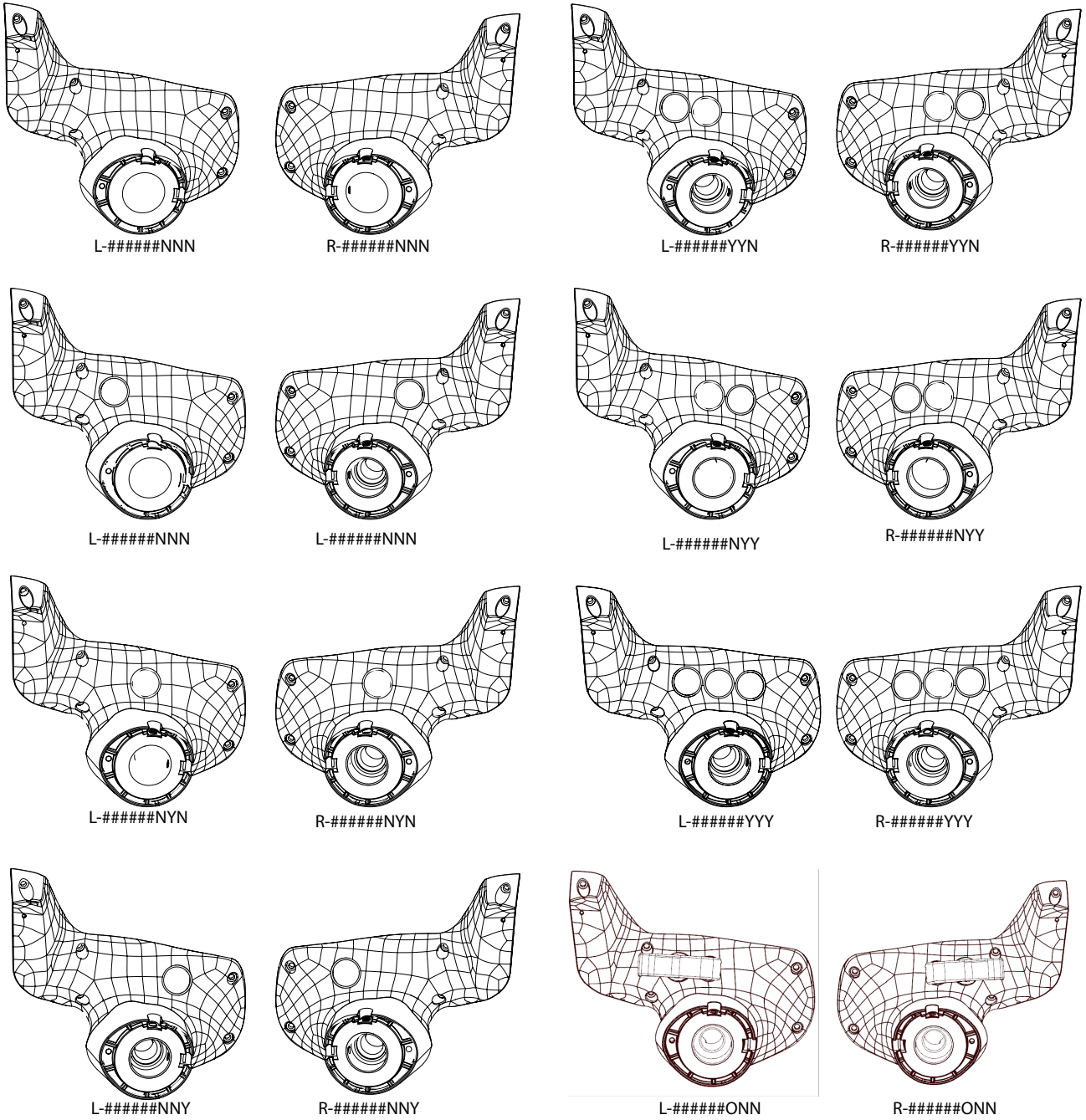

## ST2, SP2 grip



The ergonomic ST2, SP2 grip is designed to provide a solution to grip applications requiring an operator presence function. The profile of the ST2, SP2 grip, ensures that the operator's fingers are always close to the buttons to minimize operator fatigue and maximize functional control.

For applications that require high ingress protection (IP66) select the SP2 grip. For more information see F2 ordering code under *Grip model code* on page 63.

## Dimensions

ST2 grip with base dimensions in millimeters [inches]

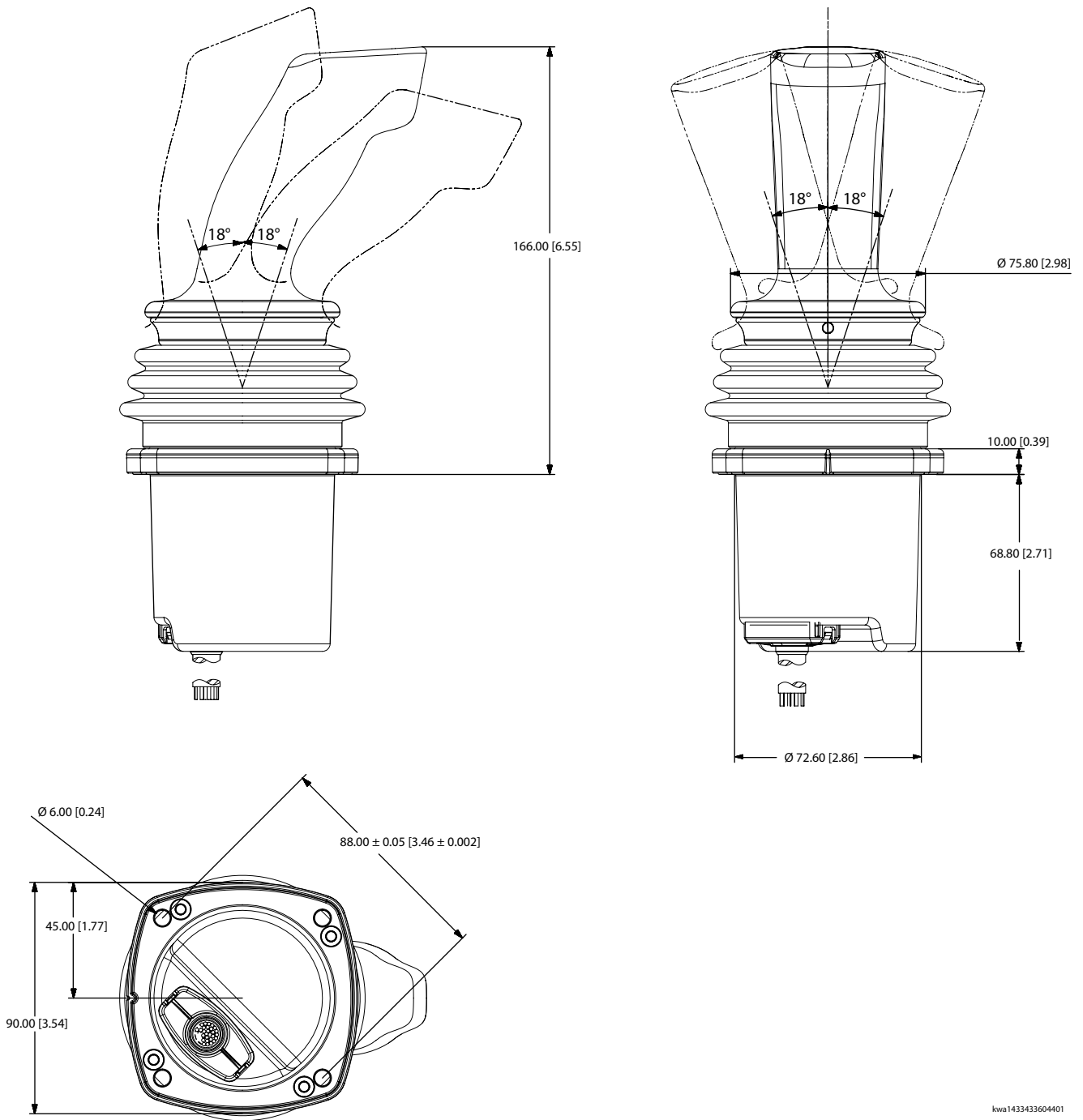

## Five total grip functions

- Front plate: Up to three functions
- Pointer finger side: one function (if nothing is placed in position 2)
- Grip rear side: Up to two functions or an Operator Presence switch

### Note

Push button = 1 function, roller/rocker/FNR/Operator Presence Switch = 2 functions

## ST2—Faceplate options

### ST2 grip faceplate options

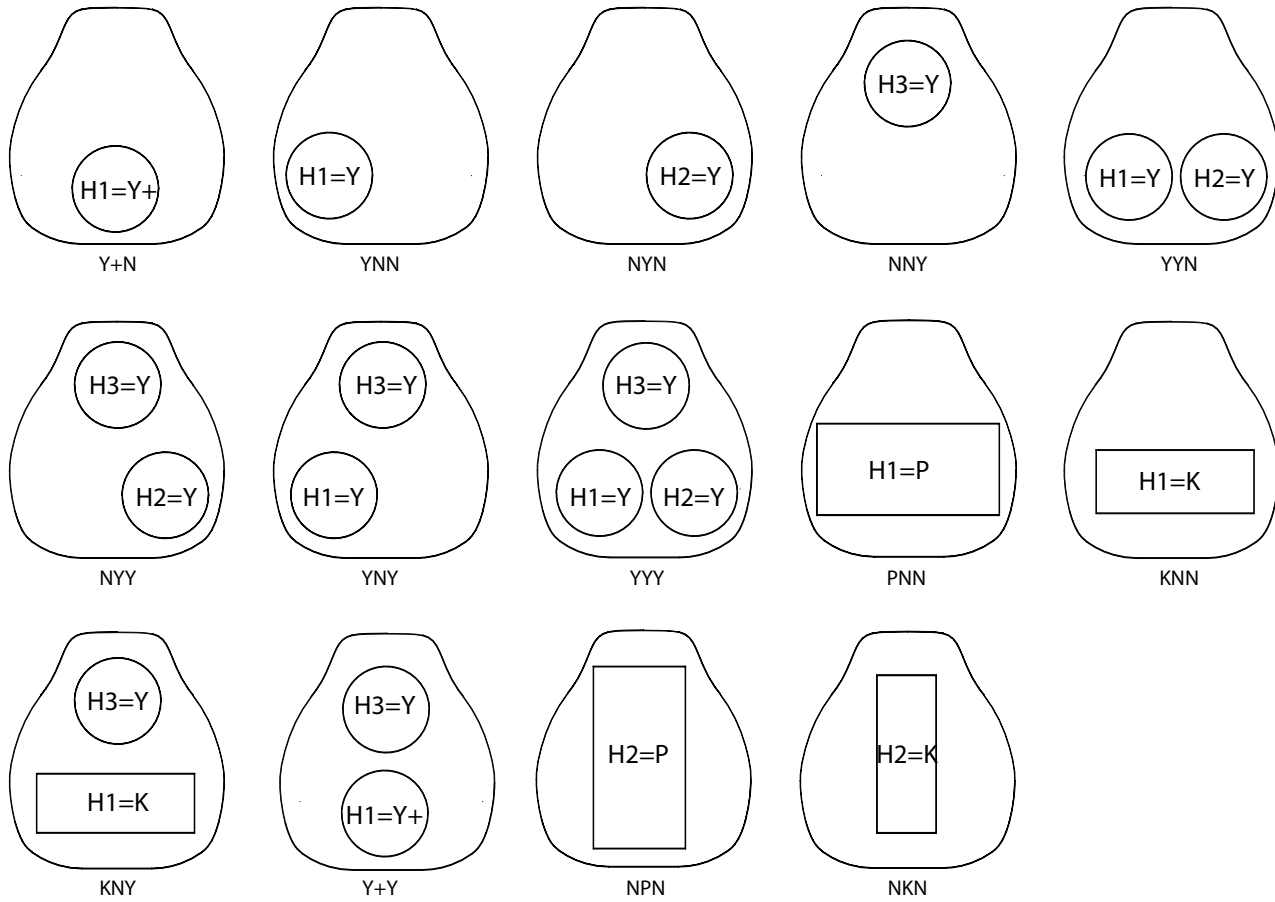

kwa1442519181260

### Related reference

## Cover options

### ST2 grip cover options

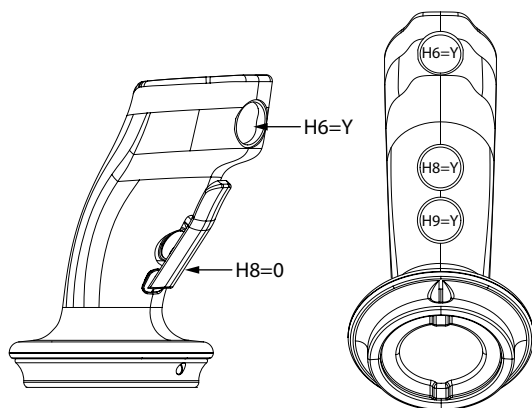

kwa1467052019867

## PR2, PP2 grip



The PR2, PP2 grip is the successor of the Prof 1. The grip features a forward-leaning, curved, ergonomic shape. The textured surface and movement pattern of the grip is designed for a comfortable user interface and maximum functional control.

For applications that require high ingress protection (IP66) select the PP2 grip. For more information see F2 ordering code under *Grip model code* on page 63.

## Dimensions

PR2 grip with base dimensions in millimeters [inches]

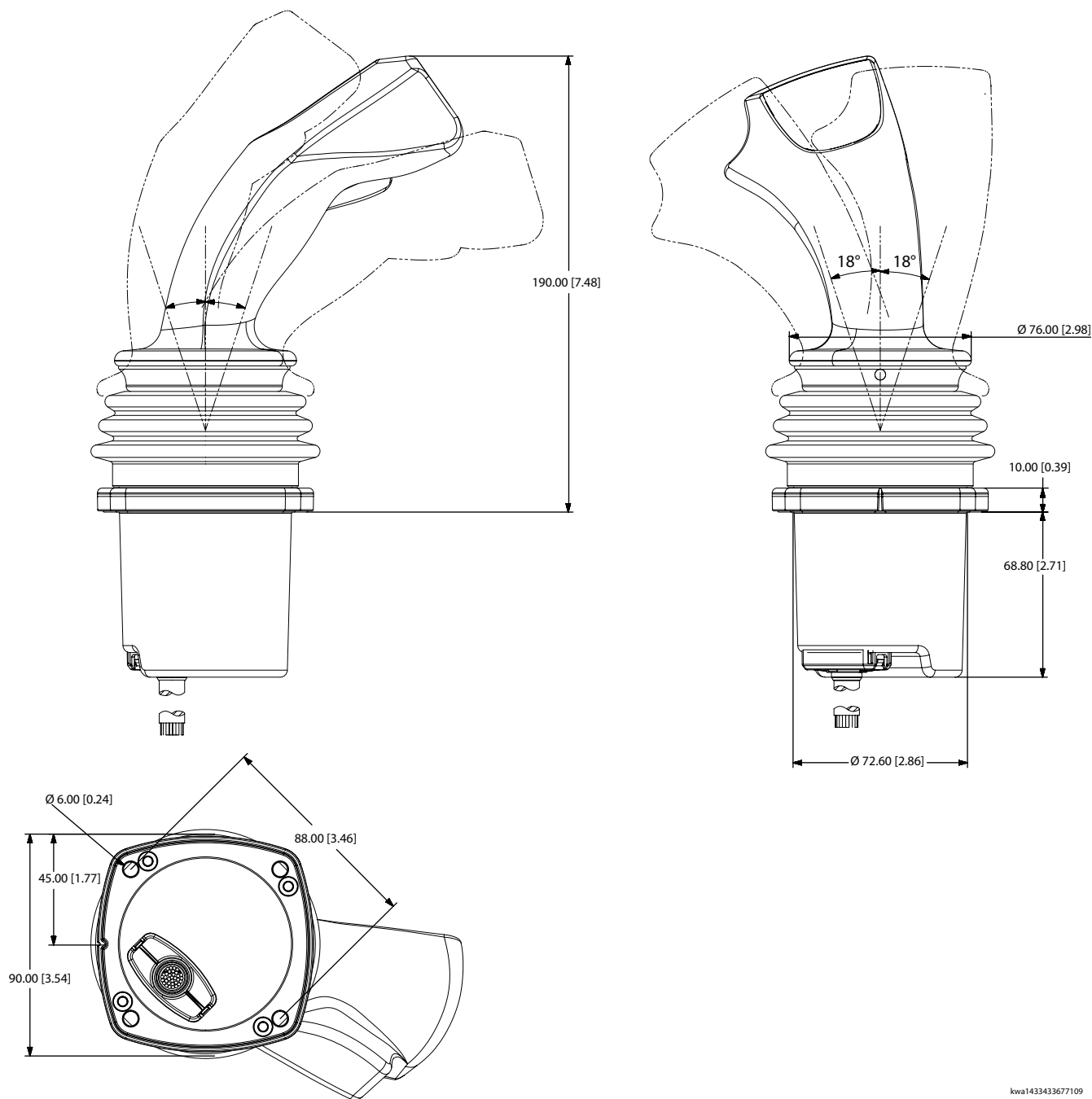

kwa143343677109

## Twelve total grip functions

- Front plate: Up to five functions
- Grip left side: Up to three functions
- Grip right side: Up to two functions
- Grip rear side: Up to two functions or an OPS

### Note

Push button = 1 function, roller/rocker/FNR/Operator Presence Switch = 2 functions

## Faceplate options

### PR2 faceplate options

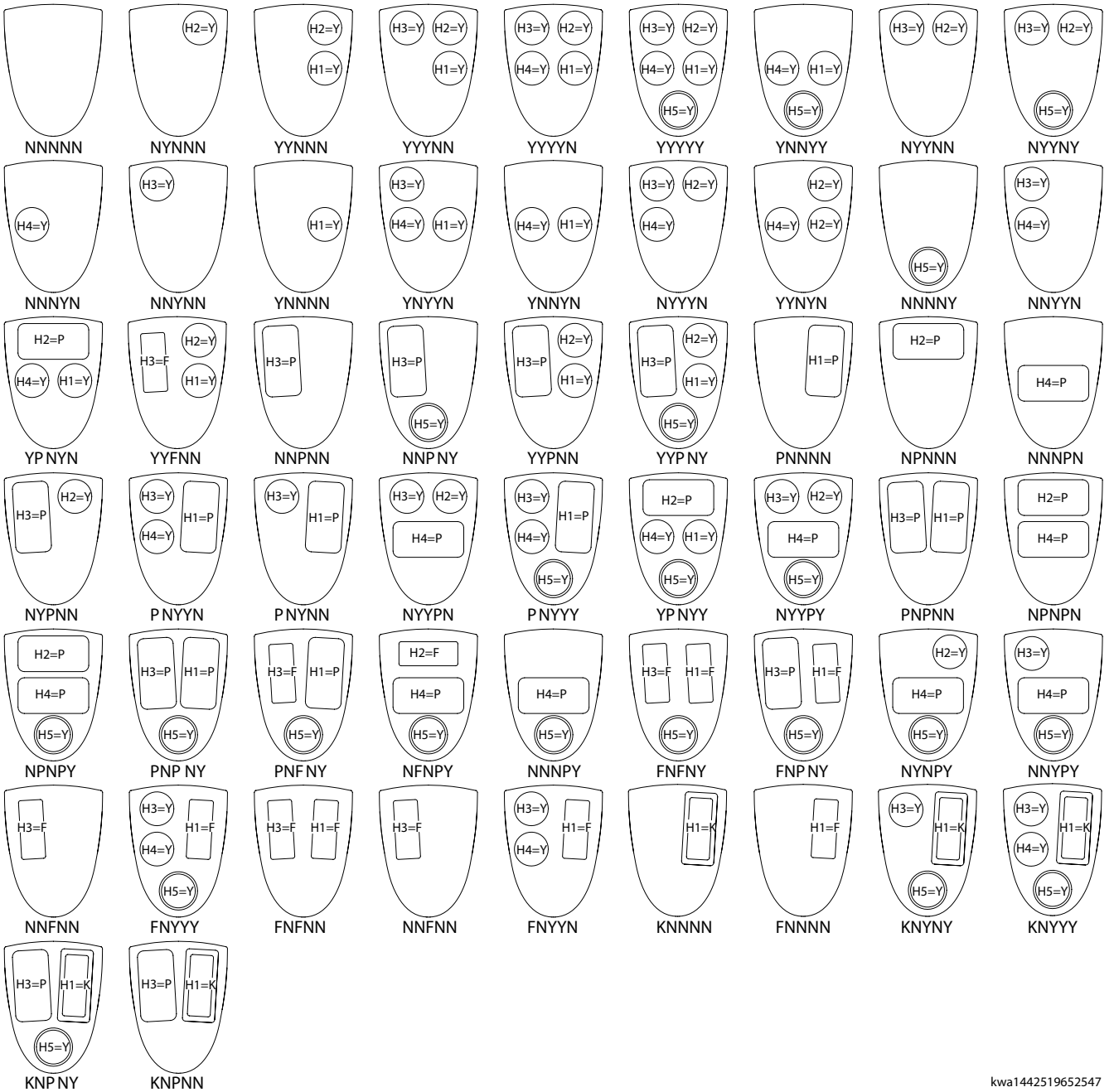

**Related reference**

kwa1442519652547

## Cover options

### PR2 cover options

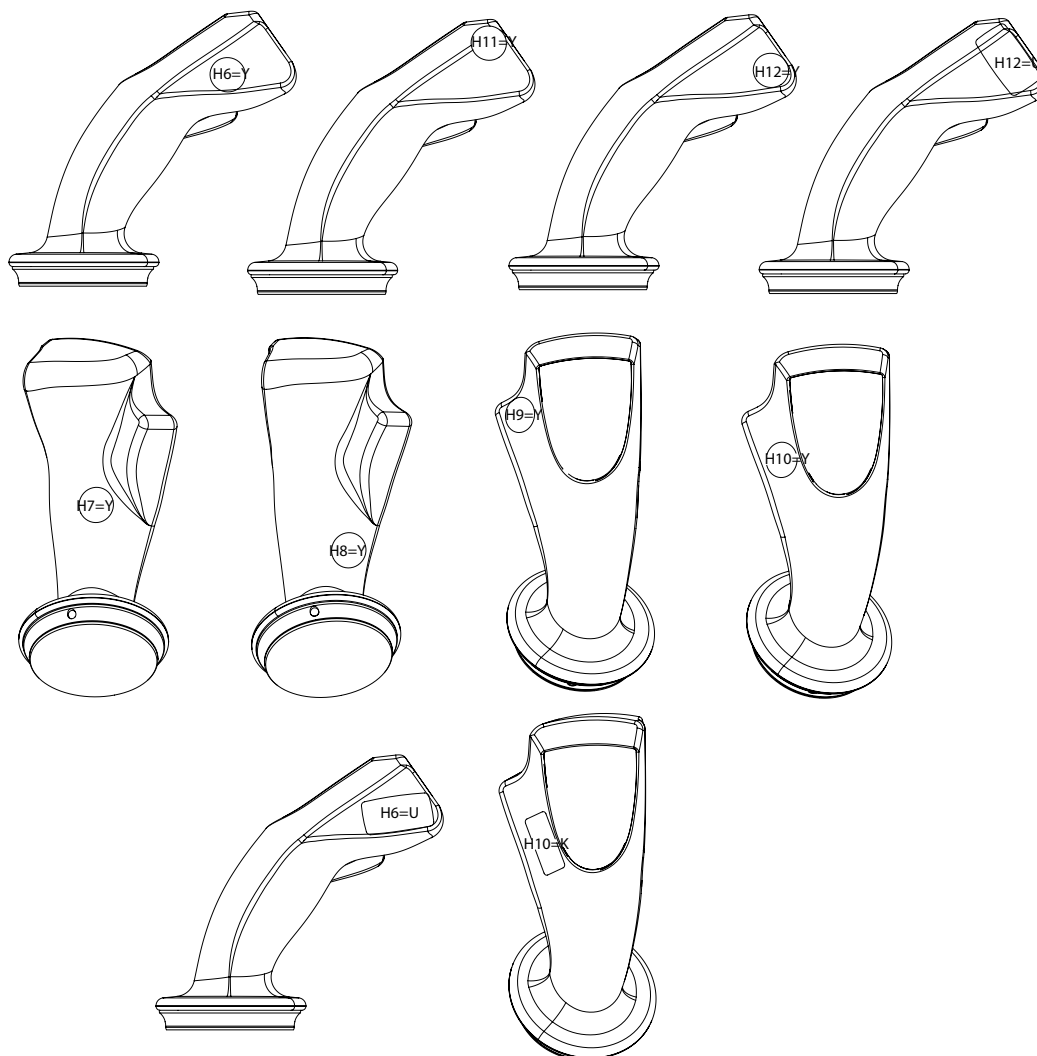

*H6 alternate position when configuring Prof1 replacement*

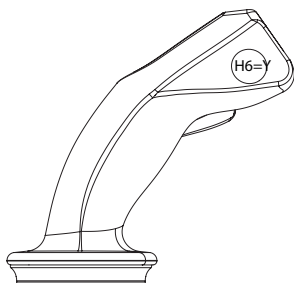

When this option is used, grip is limited to 8 functions.

## ST7, SP7 grip



The multifunction, ambidextrous, ergonomic ST7, SP7 grip is designed for a comfortable user interface and maximum functional control. The ST7, SP7 grip features a modular design that allows switch location flexibility.

The ST7, SP7 grip is available with combinations of up to 11 push-button switches, or a mix of proportional, FNR, rocker switches, and an Operator Presence switch.

For applications that require high ingress protection (IP66) select the SP7 grip. For more information see F2 ordering code under *Grip model code* on page 63.

## Dimensions

ST7 grip with base dimensions in millimeters [inches]

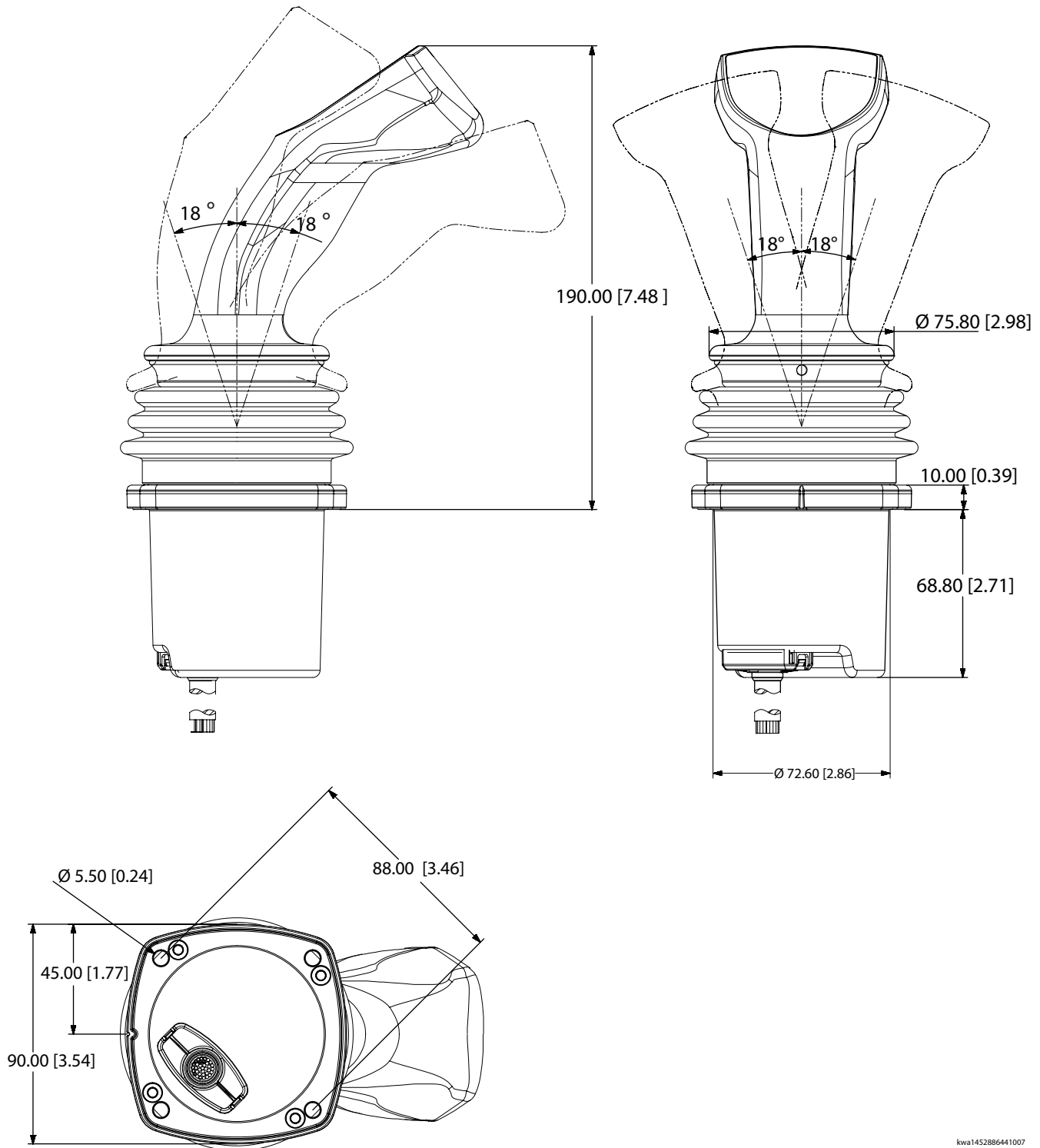



## Cover options

### ST7 cover options

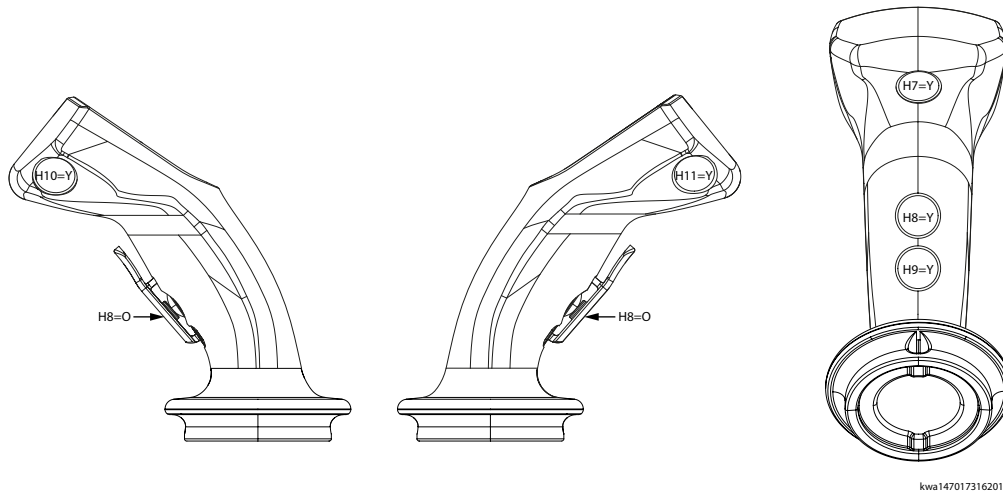

## PR7, PP7 grip



The ergonomic PR7, PP7 left and right hand grips, with easy-to-use finger tip switches, are designed for ease of access to push-button, trigger switches and proportional grip function manipulation for a comfortable user interface and maximum functional control.

The PR7, PP7 grip features quicker adaptability, especially for new and complex machines, maximizing productivity in all operating conditions.

For applications that require high ingress protection (IP66) select the PP7 grip. For more information see F2 ordering code under *Grip model code* on page 63.

## Dimensions

PR7 grip with base dimensions in millimeters [inches]

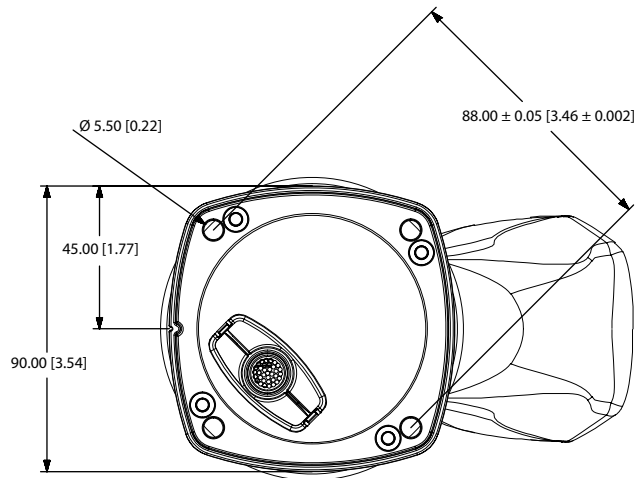
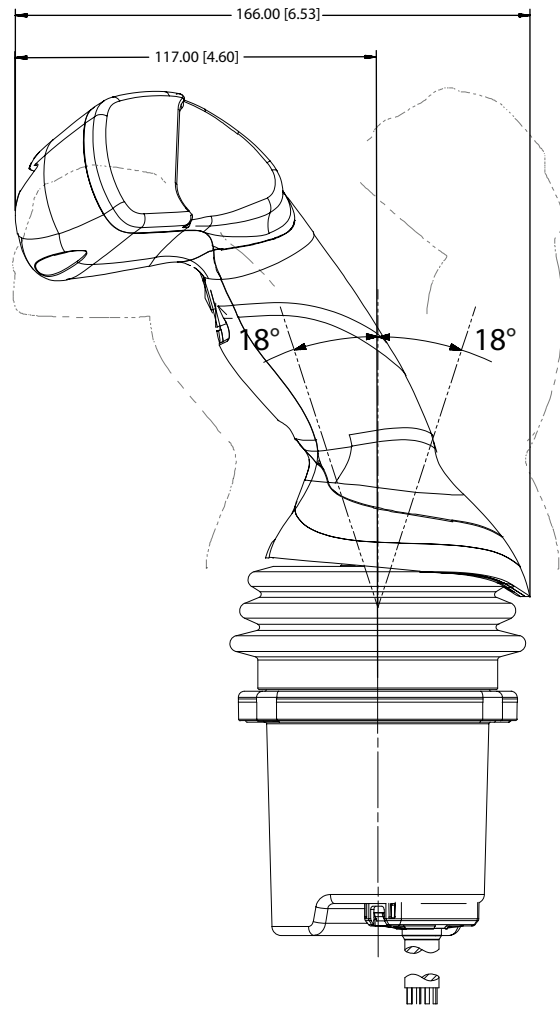
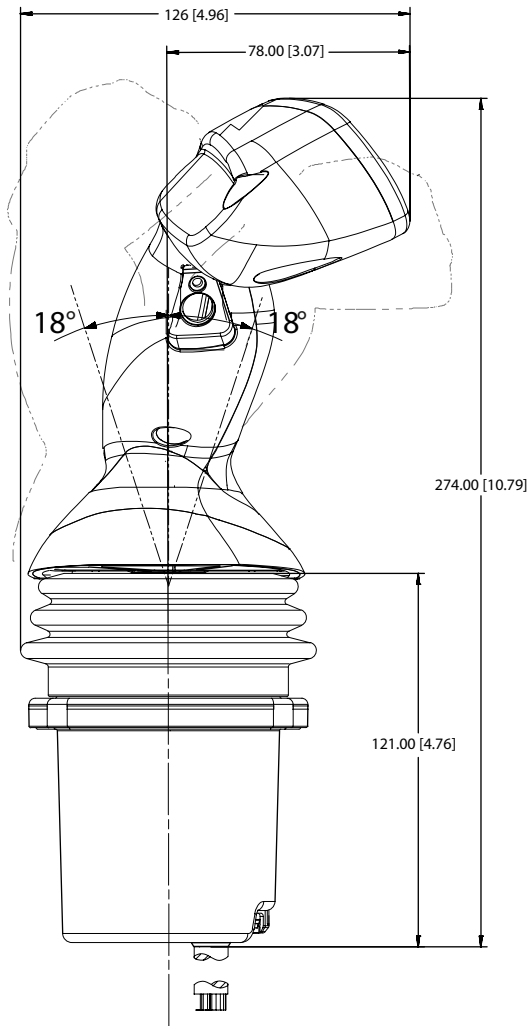

kwa1452895556296

## Faceplate options

### PR7 faceplate options

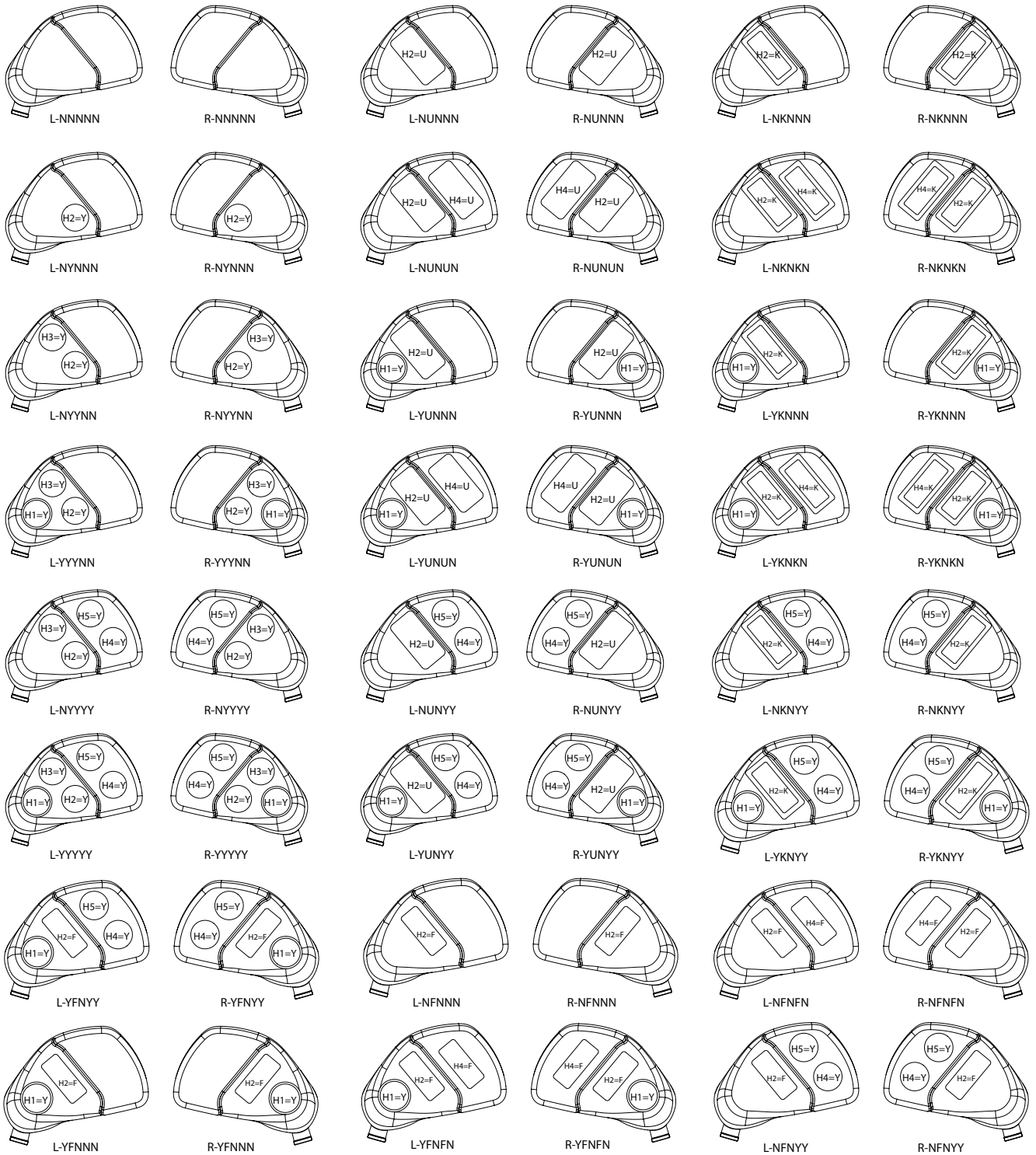

kwa1454539607113

## Cover options

### PR7 cover options

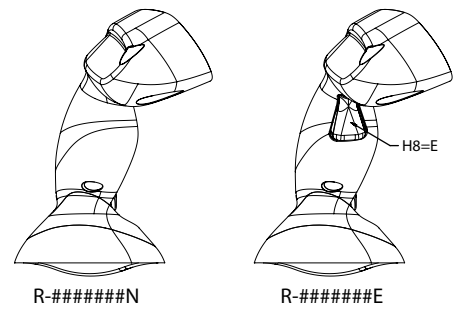
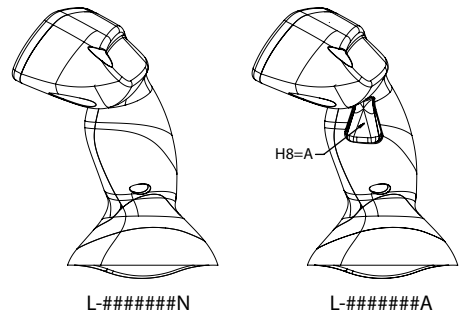
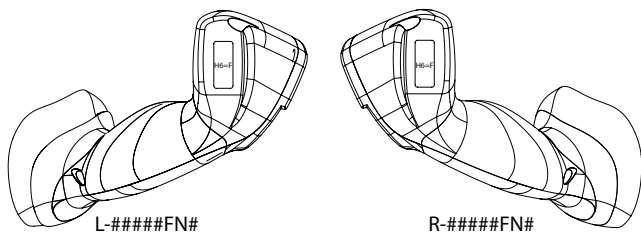
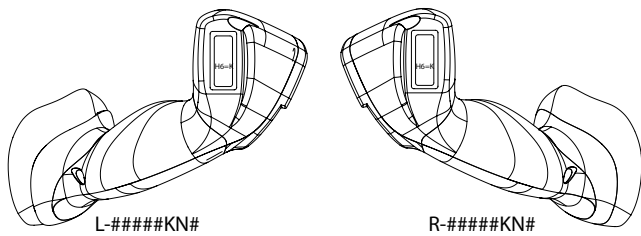
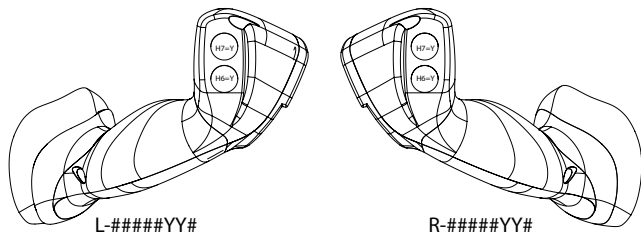
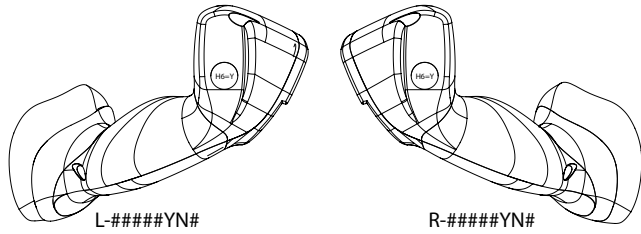
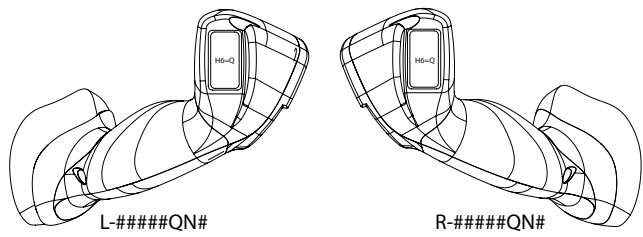
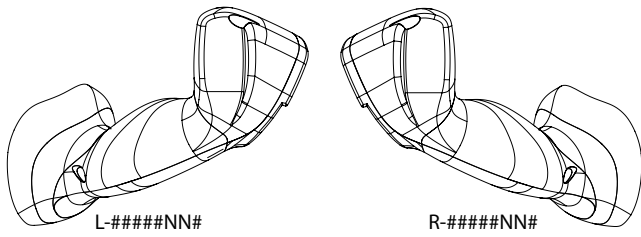

kwa145454269293

## Compatible grips

Other Danfoss grips compatible with the JS1 heavy duty base are Prof1, PVRE and PVRET which are generally used together with valves. For more information regarding Prof1, PVRE and PVRET grips please reference *Prof 1, PVRE and PVRET Joystick Technical Information Manual*, **BC152886484305**.

## Dimensions

*PVRE; and PVRET grips dimensions in millimeters [inches]*

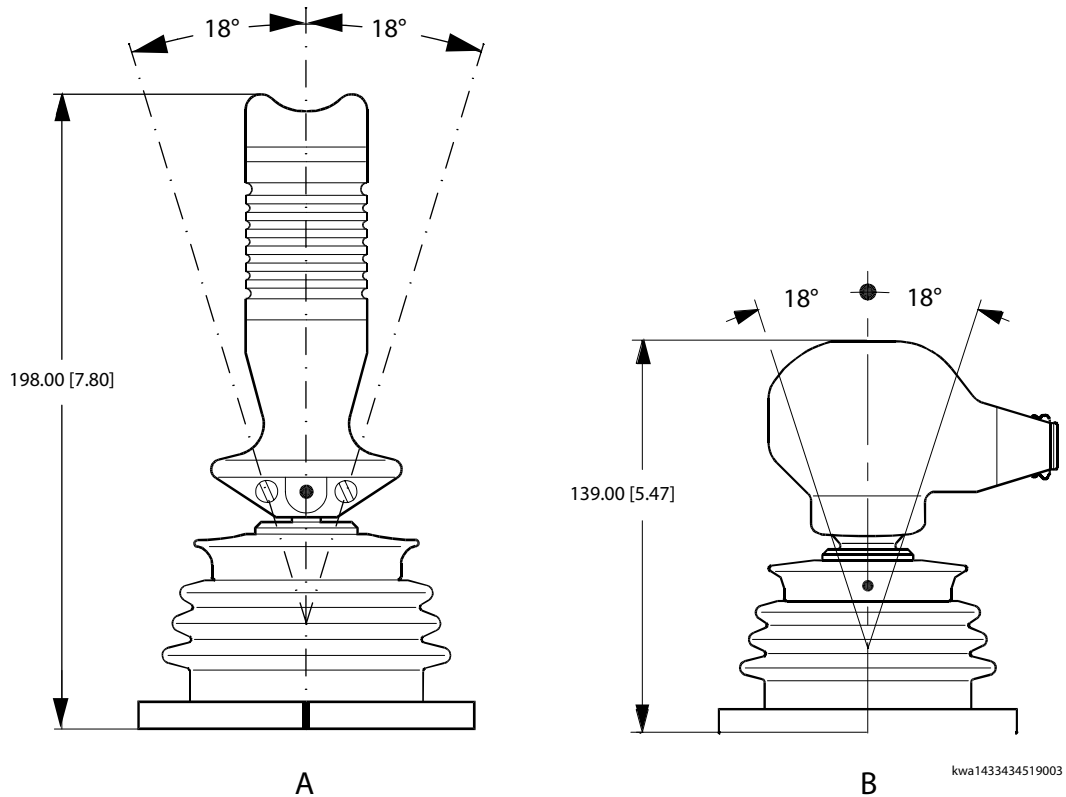

- A
  - STN grip, no switch: IP65
  - STS grip with rocker switch: IP42
  - STP grip with proportional: IP65
- B
  - STT grip: IP54

## Grip and Base only sales and service options

The JS1h grips are sellable items. Go to *Product configuration model code* on page 60 and *Grip model code* on page 63 for developing your solution.

The Base Only solution is available with all 12 digital outputs activated, as well as the respective X and/or Y axis proportional outputs calibrated. Three extra proportional outputs are available and active, but are not calibrated.

All finger functions are marked with colored tape to indicate their position on the grip. The grip locations will match to a location on the printed circuit board.

Printed circuit board

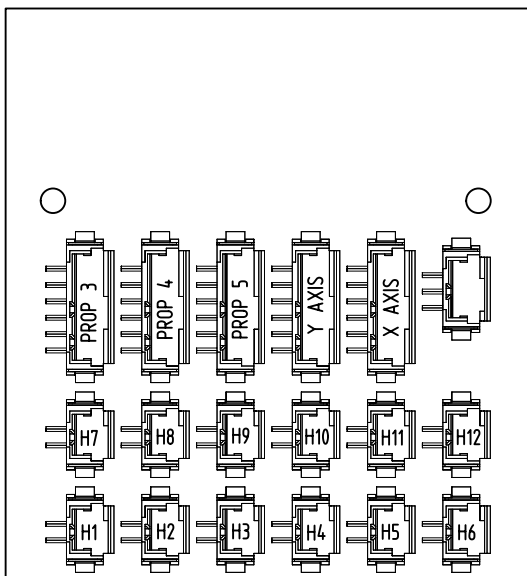

Plug in connectors accordingly

Position	Tape color
H1	Red
H2	Yellow
H3	Blue
H4	Black
H5	White
H6	None
H7	Green
H8	Blue/Black
H9	Yellow/Black
H10	Yellow/Red
H11	White/Red
H12	White/Green
Prop 3	N/A
Prop 4	Yellow
Prop 5	Red

## Base

### Dimensions

Base dimensions in millimeter [inches]

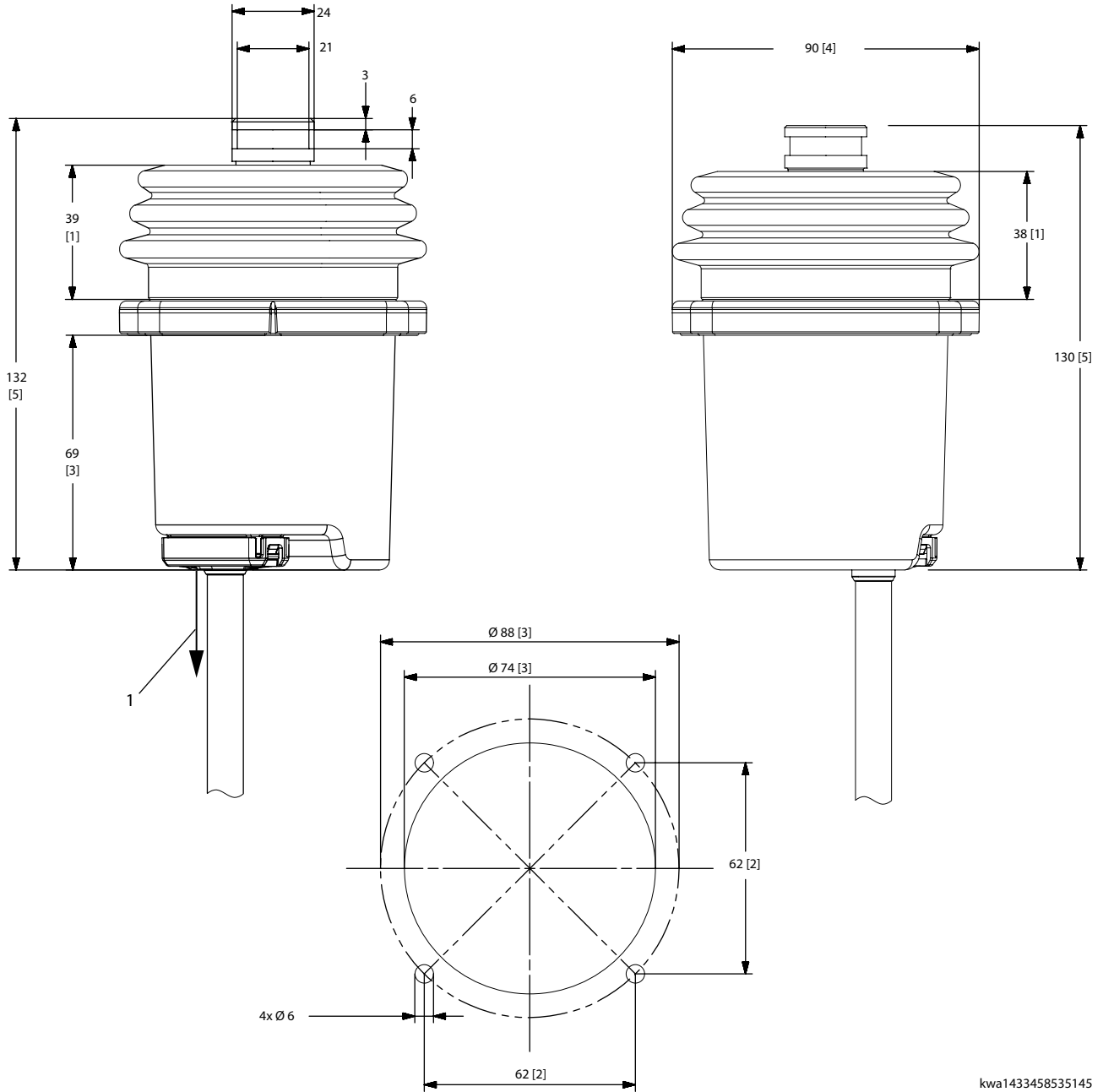

kwa1433458535145

**1. Minimum clearance from the bottom of the base:**

- 25.4 mm (1 in) for the one and two 6 pin connector cables (CAN output)
- 40 mm (1.6 in) for all other cables

**2. The maximum deflection angle of the shaft is  $\pm 18^\circ$  when activating a single axis, and  $\pm 15.9^\circ$  when activating both axis.**

**Note**

Mounting screws have a maximum torque of 7.9 N•m (69.9 in•lbf).

## Electronic modules

Due to mechanical limitations, the sensor outputs may not reach 100% output when the JS1-H joystick is moved to the corners of the base.

### CAN

The CAN heavy duty joystick provides conditioned output information in CAN 2.0B, J1939 or in CAN 2.0B, CANopen message protocols.

### CAN+

The CAN+ electronic module is designed to provide the same functionality as some of the Danfoss JS6000 and JS7000 modules. "The "+" feature set allows developers to take advantage of 4 analog and 7 digital inputs for other machine functions.

The Can+ electronic module has a sensor power output of 5.0 V<sub>DC</sub> rated for 250 mA.

### CANalog

The CANalog electronic module provides conditioned output information in CAN 2.0B, J1939 or in CAN 2.0B, CANopen message protocols. Additionally, the two X-axis outputs and the two Y-axis outputs are brought out as analog signals on the connecting cables. The outputs from any other optional analog devices, such as rollers, are also brought out to the connecting cables.

#### Additional X and Y analog outputs

There are two X-axis outputs and two Y-axis outputs on the CAN joystick. The outputs are linear with respect to the shaft angle. The two outputs of the same axis are complementary of each other, as the output voltage of one increases, the output voltage of the second decreases. The voltage output ranges from 0.5 to 4.5 V<sub>DC</sub>.

#### Proportional roller output

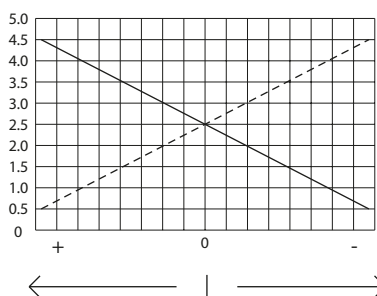

P200078

<b>Volts:</b>	Output with Halls = 0.5 to 4.5 V
<b>Solid line:</b>	Output 1
<b>Dashed line:</b>	Output 2
<b>Left arrow:</b>	Direction 1 (+ travel)
<b>Right arrow:</b>	Direction 2 (- travel)

### PVE

The PVE electronic module is designed to provide functionality the same as the Danfoss Prof1 Joystick. There are two different PVE modules, the Standard and the Extended.

## PVE—Standard

The standard level electronic module provides amplifiers, inverting and signal relays on all five proportional outputs, and an electronic switch on all eight On/Off outputs. The base also includes four analog directional outputs as equivalent to physical directional switches.

The signal relays are controlled by the power supply in such a way that a power failure will disconnect the output. When used together with a Danfoss proportional valve signal inversion, the joystick moves the spool in the direction opposite to the default. This is equivalent to swapping the hoses on the valve outlets.

 **Note**

The directional switches are not affected by the signal inversion.

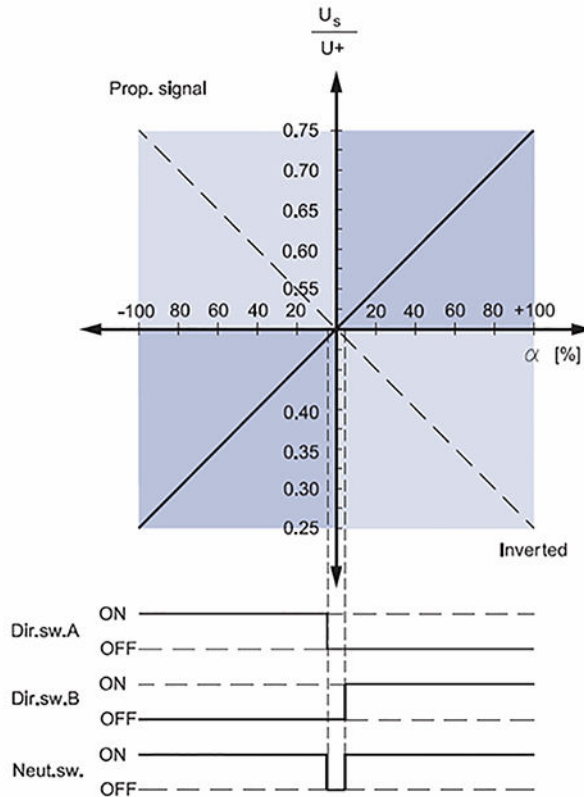

## PVE—Extended

The extended level electronic module has the same configuration as the standard level module, with the addition of four additional On/Off outputs for a total of 12 On/Off outputs. Additionally it has adjustable proportional functions. The extended level module offers the option of individual signal adaption (flow adjustment) and common dead-band compensation.

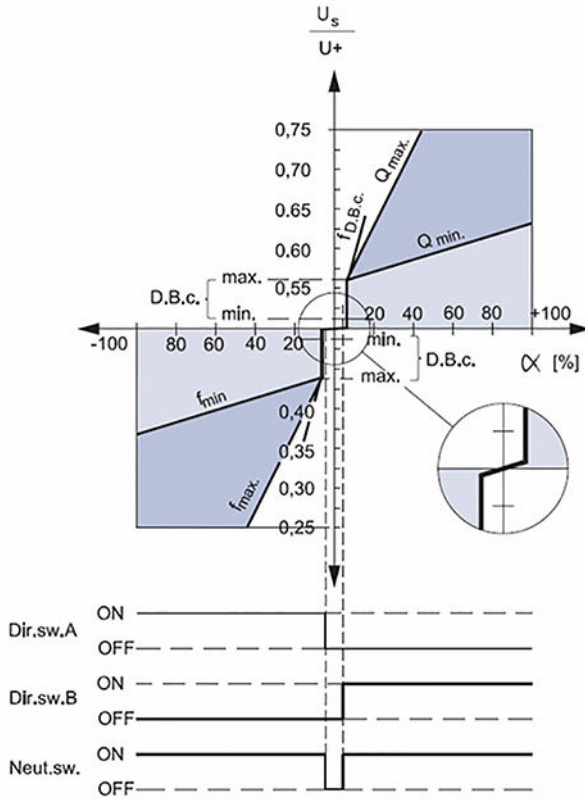

The dead band compensation ensures that the dead band of the valve is reduced to a minimum movement of the grip. The dead band compensation is only active outside the neutral range, which ensures normal amplification within the neutral position range. The dead band compensation is set for all four proportional functions on one potentiometer. For each proportional function there are two integrated potentiometers that independently control the gain for the A and B directions of the signal output without limiting the movement range of the handle (adjustable flow range). The gain of each function can be adjusted from 0.25 to 2.00. This has no effect within the dead band compensation.

## PVE - Programmable

The PVE programmable base is a fully functional PVE joystick that allows for customers to develop their own solution using PLUS+1® Guide as well.

### Non-Redundant Analog interface (CAT1)

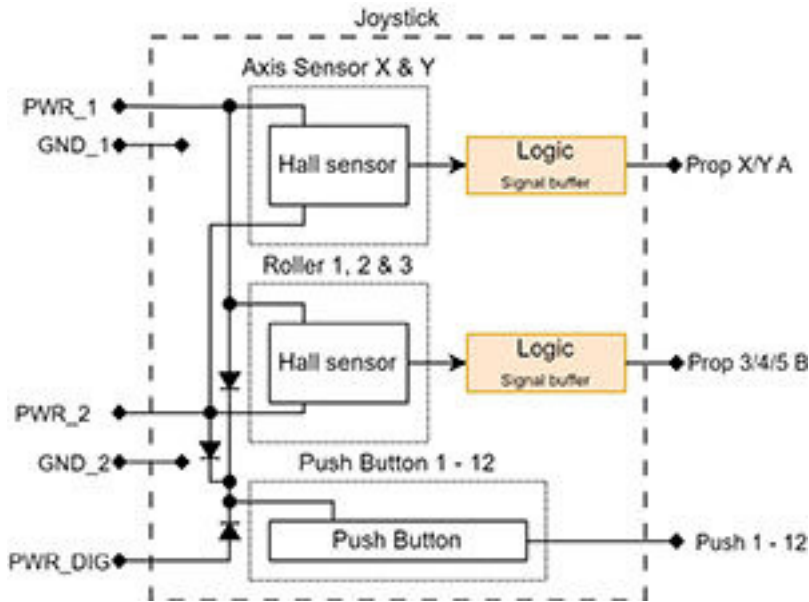

The Non-Redundant Analog interface provides single channel X-axis and Y-axis output signals by a pure analog platform that contains no active electronics. This version offers raw signals from function modules, proportional modules, and push buttons. This module is available only with Hall effect sensing elements. The Hall effect base is limited to 5 V<sub>DC</sub> input power and provides an output of 10 to 90% of the input voltage.

### Full-Redundant Analog interface (CAT3)

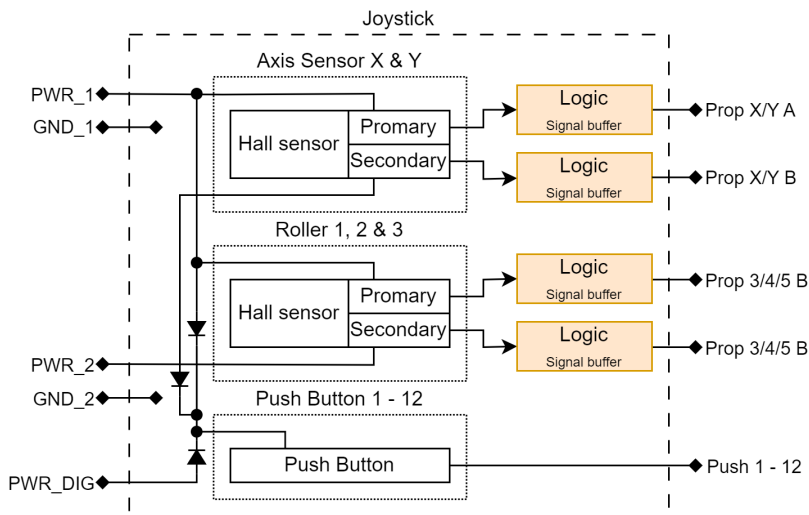

In addition to the features of the Analog Category 1 electronic module, the Analog Category 3 interface provides redundant X- and Y-axis output signals with separated power supply and ground connections.

Due to mechanical limitations, the sensor outputs may not reach 100% output when the JS1-H joystick is moved to the corners of the base.

### PWM (Programmable)

The PWM base features 4 PWM and 2 On/Off type outputs. This joystick is shipped with no application installed and allows for customers to develop their own solution using PLUS+1® GUIDE.

Not all of the joystick functions are released for the PWM base. See *Joystick functions* on page 44 for details.

## Connection diagrams

### CAN+

Numbers in [] indicate external DTM pin number.

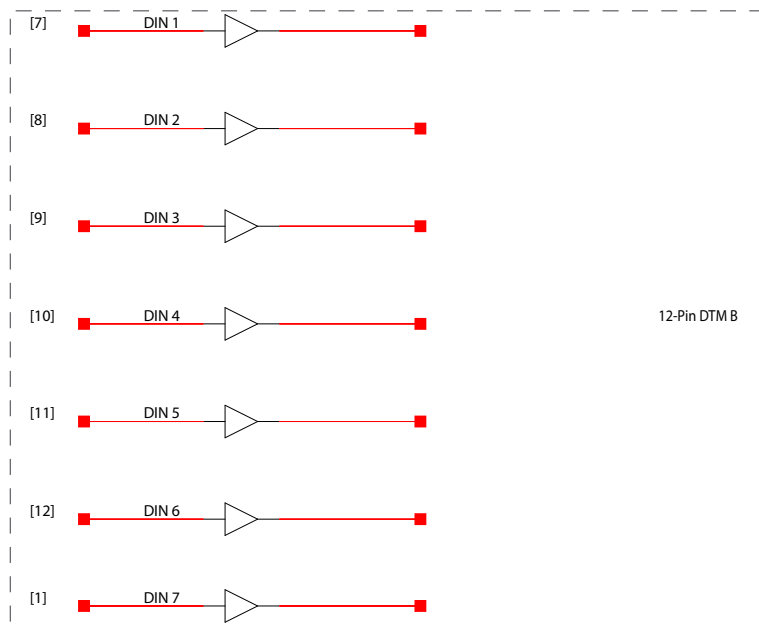
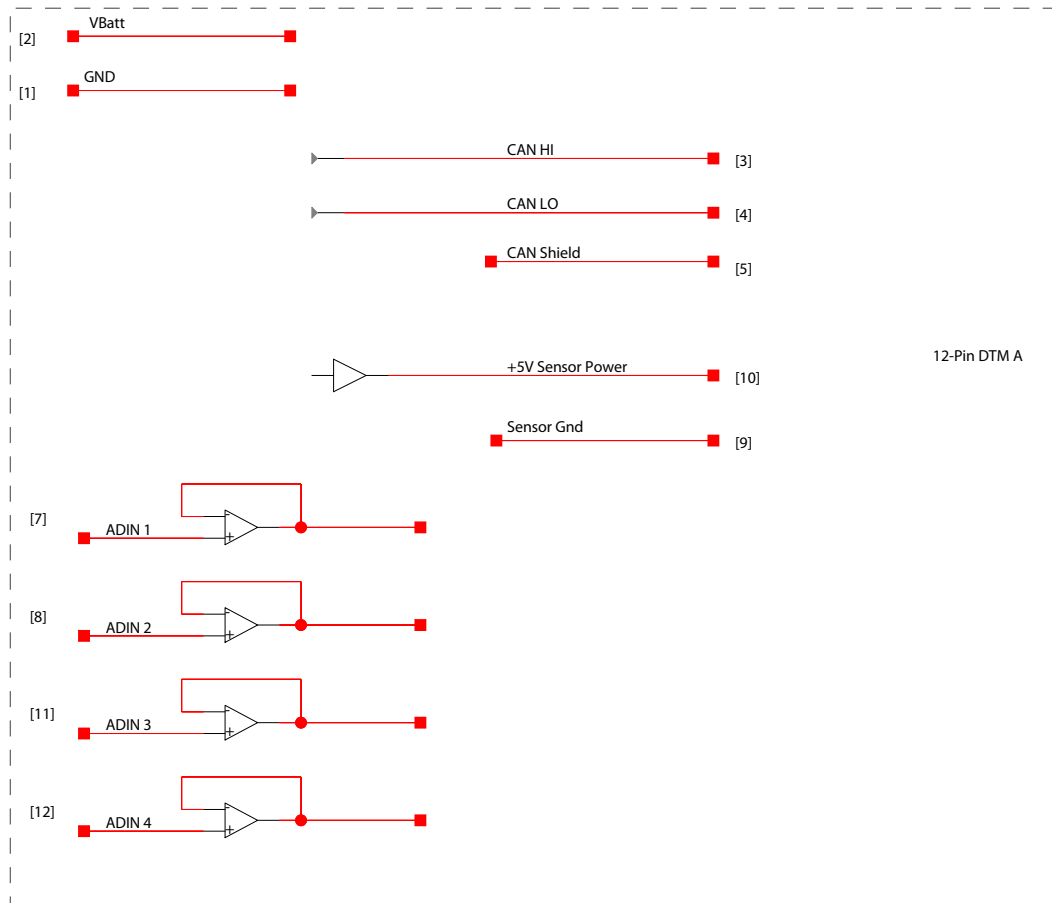

## CANalog

Numbers in [] indicate external DTM pin number, numbers in {} indicate external 18 pin DT pin number.

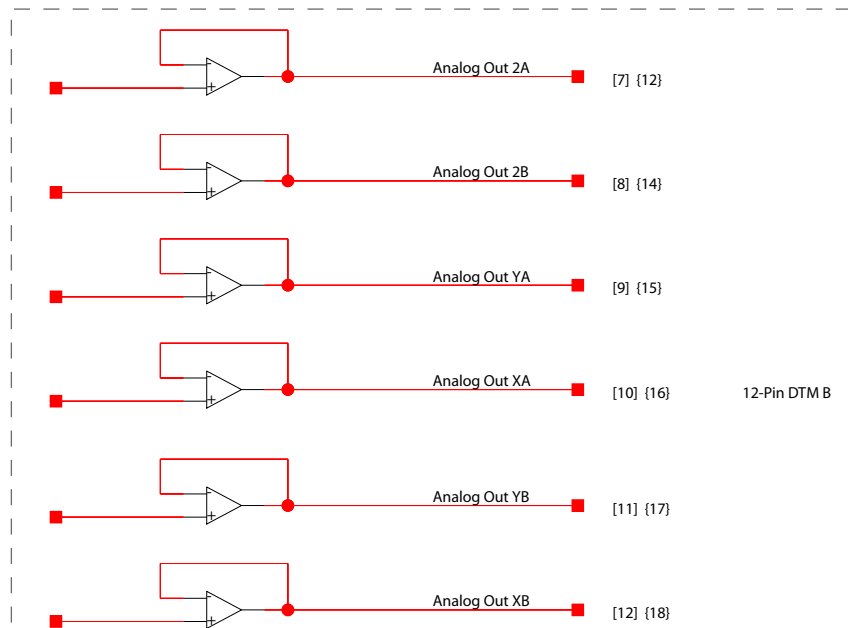
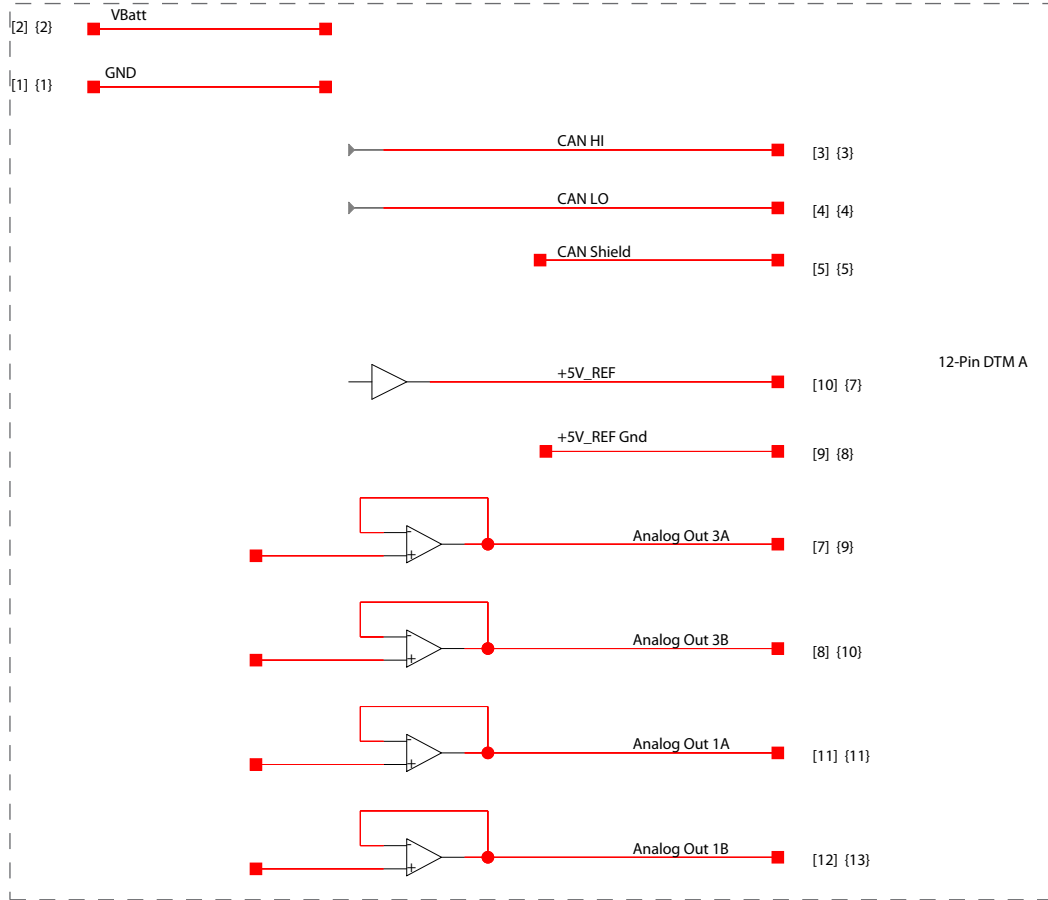

PVE DSUB

Numbers in [ ] indicate the DB25 connector pin number.

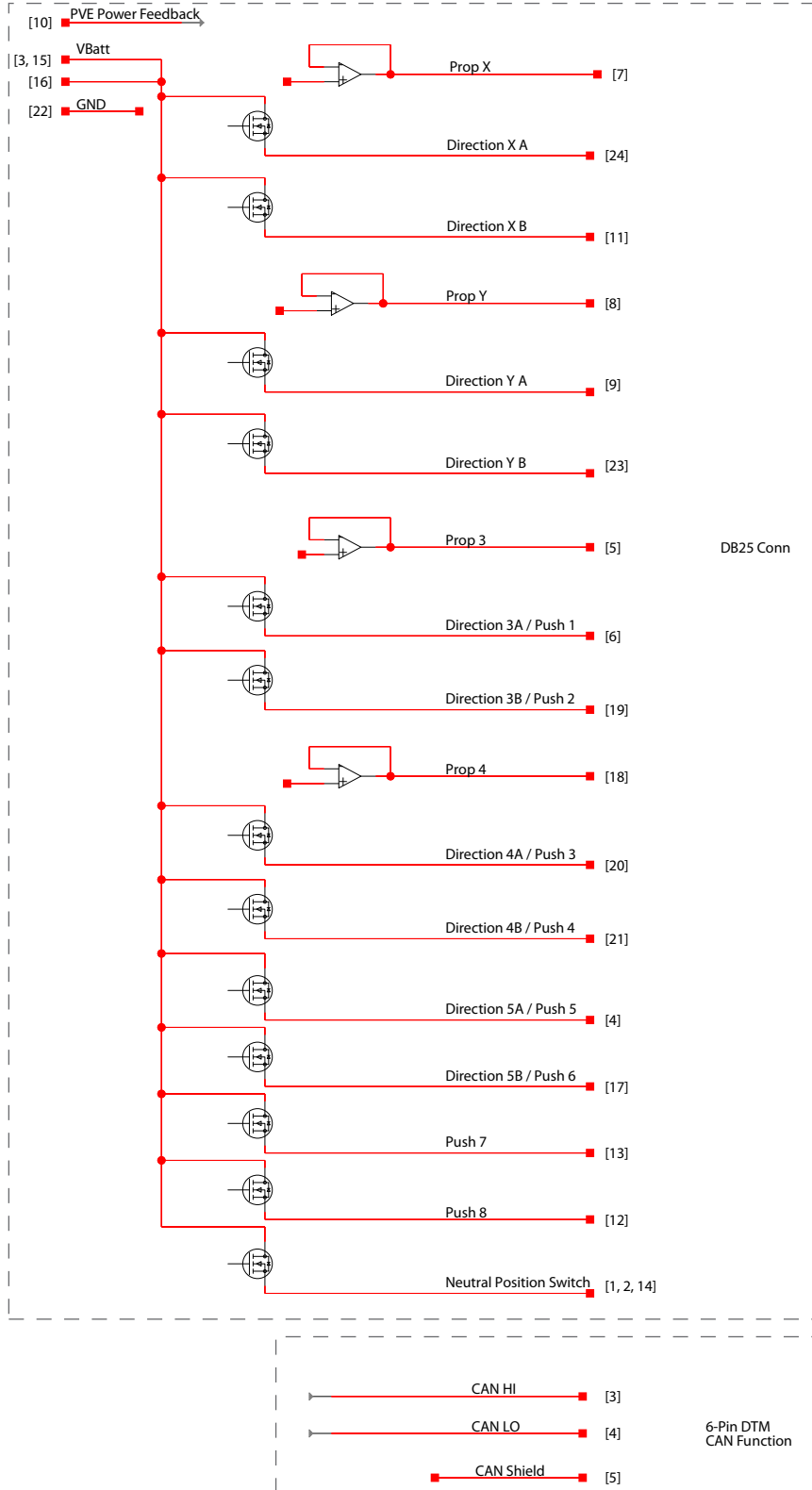

# Analog Cat 1

Numbers in [ ] indicate external DTM pin number

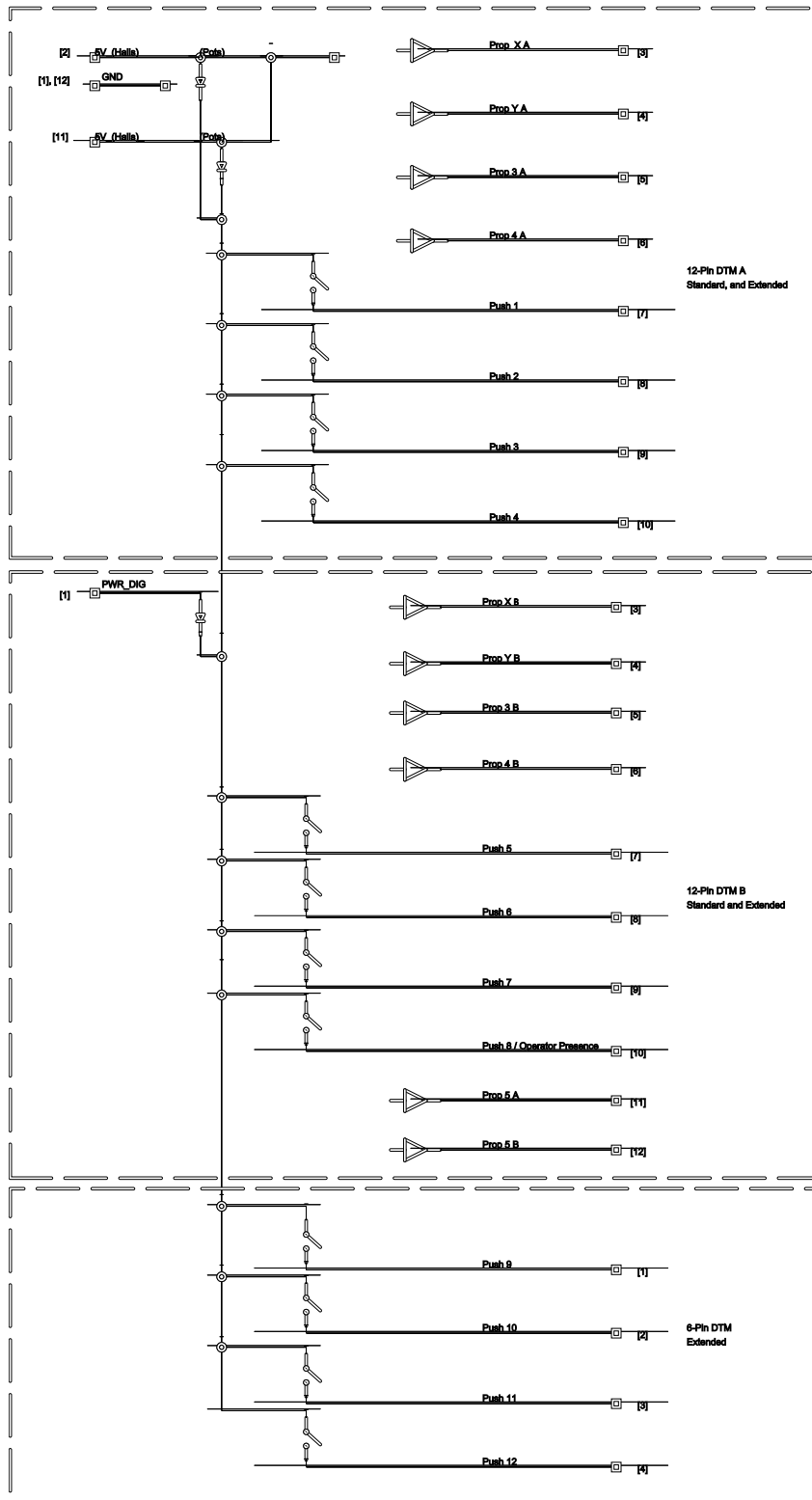

## Analog Cat 3

Numbers in [ ] indicate external DTM pin number.

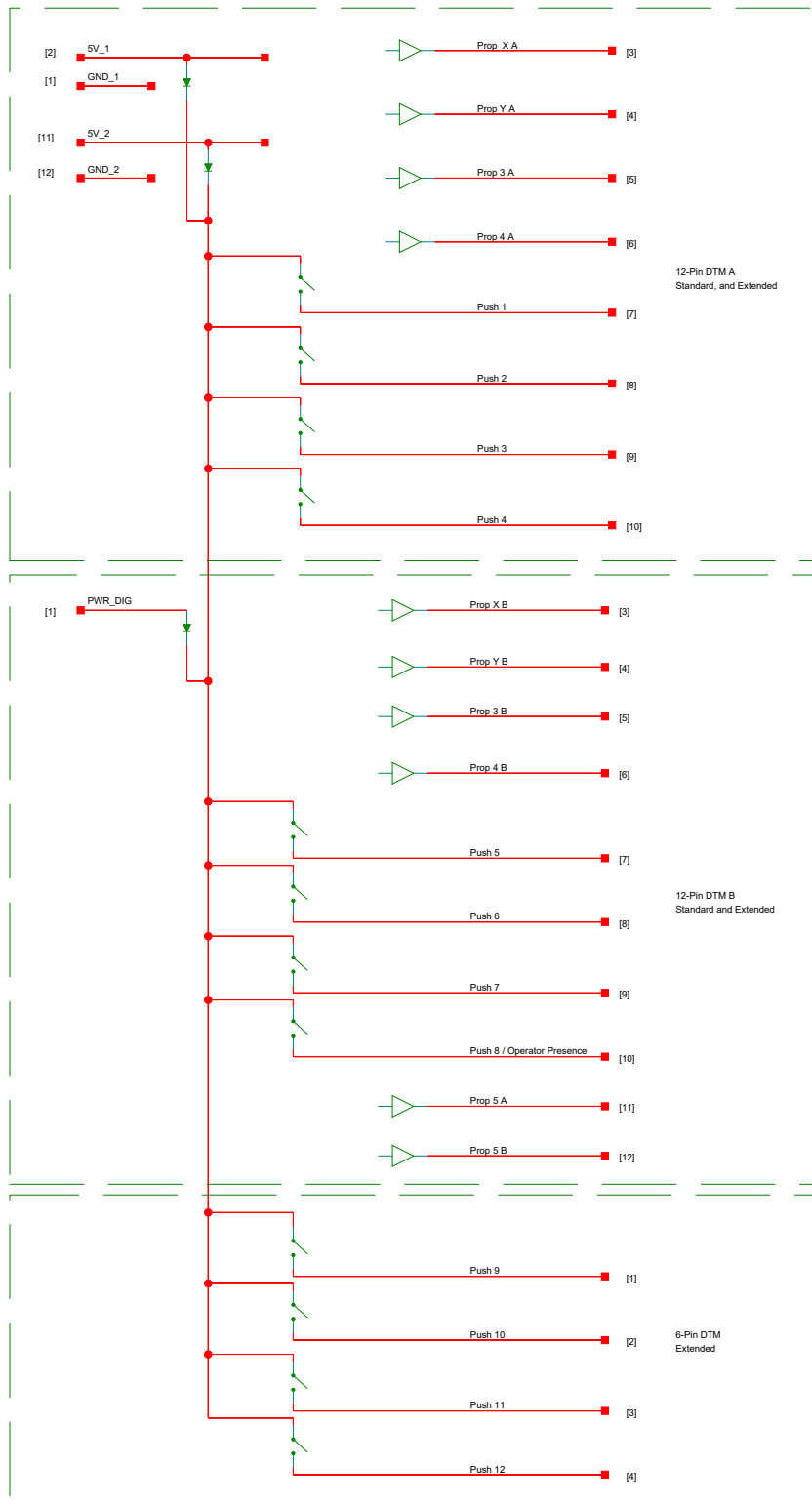

# PVE Deutsch

Numbers in [] indicate external DTM pin number.

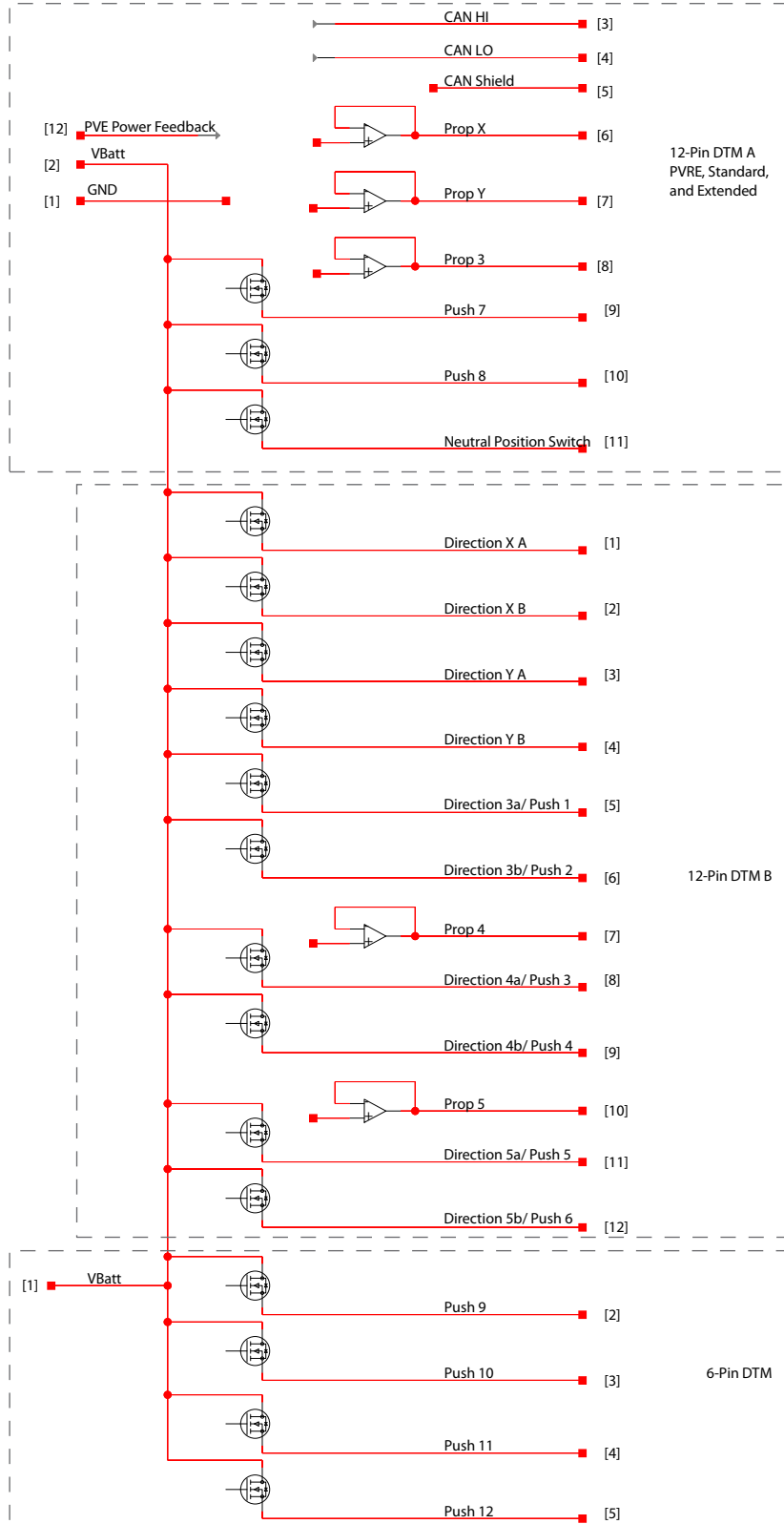

## PWM

Numbers in [] indicate external DTM pin number.

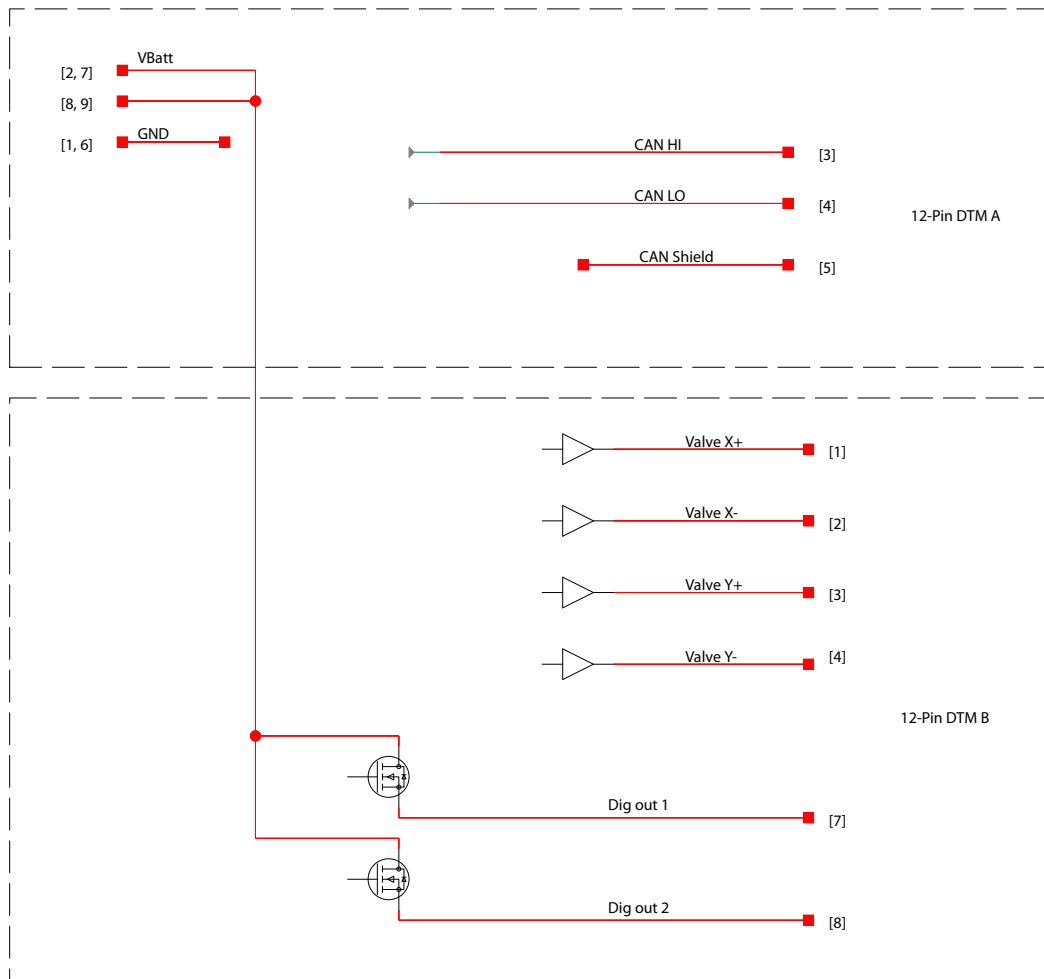

## Specifications

### Mechanical

#### Mechanical characteristics

<b>Shaft mechanical angle limits</b>	± 18° (deg) single axis activation +/-15.9 (deg) dual axis activation
<b>Base mechanical life</b>	Single axis with friction, with potentiometer sensor
	<b>Single axis with friction, with hall effect sensor = 2 million full operating cycles</b>
	<b>Single axis and dual axis with spring return = 2.0 million full operating cycles</b>
	<b>Single axis and dual axis with spring return, with potentiometer sensor</b>
	<b>Single axis and dual axis with spring return, with hall effect sensor = 15 million full operating cycles</b>
<b>Maximum force on handle</b>	1000 N
<b>Maximum torque</b>	15 Nm
<b>Base only mass</b>	0.75 kg (1.65 lbf)
<b>Weight (base without grip)</b>	725 N (1.8 lb)
<b>Vertical maximum load</b>	2500 N (560 lbs)

#### Sprint return, base only

<b>Breakout load on axis</b>		
Standard duty spring: 6 to 8.5 N (1.4 to 1.9 lbf)	Heavy duty spring: 12 to 19 N (2.7 to 4.3 lbf)	Extra heavy duty spring: 17 to 22 N (3.8 to 4.7 lbf)

#### Friction hold, base only

<b>Friction level</b>		<b>Friction</b>	<b>Center detent</b>
A	Low friction-Low detent	0.8 Nm	1.5 Nm
B	Low friction-Low detent	0.8 Nm	2.0 Nm
C	High friction-High detent	1.6 Nm	3.0 Nm

#### Friction hold/Spring return, base only

<b>Friction level</b>		<b>Spring type</b>
E	A	Standard
J	A	Heavy

#### EMC characteristics

<b>Validation test</b>	<b>Standard</b>	<b>Severity</b>
Radiated EMI	ISO 13766	150 V/m
Conducted EMI		100 mA
Radiated EMS		CISPR 25 class 3
Automotive transients on power lines pulses 1, 2a, 2b, 3a, 3b	ISO 7637-2	
Automotive transients on signal lines pulses a, b	ISO 7637-3	
Load dump	ISO 7637-2 Pulse 5a	12 V & 24V system
Startup - Cranking	ISO 16750 Pulse 4	Test level 4 for 12V
ESD	EN 61000-4-2, SAE J1113-13	Air 15kV, Contact 8kV

## Electrical—CAN, CAN+, and CANalog

### Electrical—CAN, CAN+, and CANalog characteristics

<b>Sensor type</b>	Hall effect with redundant sensors Potentiometer
<b>Resolution</b>	12 bit
<b>Supply voltage (V<sub>s</sub>)</b>	9 to 36 V <sub>DC</sub>
<b>Output</b>	J1939 and CANopen protocols
<b>Can+ Sensor Power</b>	5.0 V <sub>DC</sub> +/- 5% at 250 mA
<b>CANalog volt reference</b>	5.0 V <sub>DC</sub> +/- 5% at 50 mA
<b>Base maximum current consumption</b>	120 mA at 9 V
<b>CANalog analog outputs</b>	0.5 to 4.5 V <sub>DC</sub> at 1 mA max

## Electrical—PVE (Standard and Extended)

### Electrical—PVE (Standard and Extended) characteristics

<b>Supply voltages</b>	<b>U<sub>DC</sub></b>	9 to 36 V <sub>DC</sub>
<b>Maximum current consumption</b>		8 A
<b>Current consumption, no load</b>		150 mA
<b>Maximum load for push buttons and directional switches for all proportional functions</b>		0.6 A
<b>Neutral position switch</b>		3 A
<b>Sensor type</b>		Hall effect with redundant sensors Potentiometer
<b>Signal voltage U<sub>s</sub></b>	<b>Minimum to maximum</b>	0.25 to 0.75
	<b>Neutral position</b>	0.50
<b>Signal load in neutral position</b>	<b>Load type</b>	<b>PVE</b>
	<b>Load impedance</b>	>6 kΩ
		<b>Other</b>
		>15 kΩ
<b>Signal current at maximum movement</b>	<b>U<sub>DC</sub> = 12 V</b>	<b>6 kΩ</b>
		± 0.6 mA
	<b>U<sub>DC</sub> = 24 V</b>	<b>15 kΩ</b>
		0.2 to 0.6 mA
		0.4 to 1.2 mA
<b>Signal current in neutral position</b>	<b>U<sub>DC</sub> = 12 V</b>	± 0 mA
	<b>U<sub>DC</sub> = 24 V</b>	± 0 mA
		± 0.4 mA
		± 0.8 mA
<b>Inverter</b>	<b>Non inverted</b>	Output signal = U <sub>s</sub>
	<b>Inverted</b>	Output signal = -1 x (U <sub>s</sub> - 0.5 x U <sub>+</sub> ) + 0.5 x U <sub>+</sub>

## Electrical—PVE (Extended only)

### Electrical—PVE (Extended only) characteristics

<b>Signal regulation U<sub>s</sub></b>	<b>U<sub>s</sub> Minimum (50%)</b>	0.37 to 0.63 at 100% movement
	<b>U<sub>s</sub> Maximum (200%)</b>	0.25 to 0.75 at 50% movement
<b>Dead band compensation</b>	<b>U<sub>s</sub> Minimum</b>	0.00
	<b>U<sub>s</sub> Maximum</b>	0.06

## Electrical—Analog Cat 1, Cat 3

### Electrical—Analog Cat 1, Cat 3 characteristics

<b>Sensor type</b>	Hall effect with redundant sensors
<b>Supply voltage (Vs)</b>	4.5 to 5.5 V <sub>DC</sub>
<b>Output</b>	10 to 90% of input voltage

*Electrical—Analog Cat 1, Cat 3 characteristics (continued)*

<b>Output impedance</b>	1 mA max output current at 200 Ohm output impedance
<b>Digital outputs</b>	Vs-0.3 V <sub>DC</sub> , maximum current 100 mA

Electrical—PWM

*Electrical—PWM (programmable) characteristics*

<b>Sensor type</b>	Hall effect with redundant sensors
	Potentiometer
<b>Resolution</b>	12 bit
<b>Supply voltage (Vs)</b>	9 to 36 Vdc
<b>Current consumption, no load</b>	120 mA
<b>Maximum current consumption</b>	15 A
<b>Outputs (3 amps)</b>	PWM(4)
	Digital(2)

Environmental

*Environmental characteristics*

<b>Operating temperature</b>	CAN, CANalog, CAN+, Analog Cat1, Analog Cat3, PWM	-30° C to 80° C (-22° F to 176° F)
	PVE	-30° C to 70° C (-22° F to 158° F)
<b>Storage temperature</b>	-40° C to 85° C (-40° F to 185° F)	
<b>EMI/RFI rating</b>	150 V/m	
<b>Vibration</b>	25 G, 10 ms, 500 bumps in each of 6 directions IEC 60068-2-29 test Eb	
<b>Shock</b>	50 G, 11 ms, 3 shocks in each of 6 directions IEC 60068-2-29 test Ea	
<b>Ingress Protection (IP) rating</b>	Up to IP 66 (dependent on grip sealing selected)	





For more information regarding IP rating reference F2—Grip type, *Grip model code* on page 63

*EMC characteristics*

Validation test	Standard	Severity
Radiated EMI	ISO 13766	150 V/m
Conducted EMI		100 mA
Radiated EMS		CISPR 25 class 3
Automotive transients on power lines pulses 1, 2a, 2b, 3a, 3b	ISO 7637-2	
Automotive transients on signal lines pulses a, b	ISO 7637-3	
Load dump	ISO 7637-2 Pulse 5a	12 V & 24V system
Startup - Cranking	ISO 16750 Pulse 4	Test level 4 for 12V
ESD	EN 61000-4-2, SAE J1113-13	Air 15kV, Contact 8kV

## Joystick functions

### Grip options

Name	Image	Option	Switch functions quantity	Push buttons quantity	Roller/rocker quantity	Alternative configuration
HR1		Left hand and right hand grip	10	10	3	2 rollers or rockers with 4 push buttons
ST2		Ambidextrous grip	5	5	1	1 roller or rocker with 1 push button and 1 Operator Presence switch
PR2		Left hand and right hand grip	12	11	3	3 rollers or rockers with 3 push buttons and 1 Operator Presence switch
ST7		Ambidextrous grip	11	11	2	2 rollers or rockers with 2 push buttons and 1 Operator Presence switch
PR7		Left hand and right hand grip	8	7	3	3 rollers or rocker with 1 push button and 1 trigger switch

### Hx Nomenclature

Simplified Nomenclature	Complete Nomenclature
F	F1x, T1x
K	K1x
M	M1x, M7x
N	NNN
O	O1x, O2x
P	P1x, S1x, V1x, V3
U	Q1x, U1x, V2x, V4x
Y	11x, 21x, 31x, 41x, 51x, 61x, B1x, G1x, H1x, L1x, R1x, W1x, Y1x

Suffix "x" used to determine with which bases its configurable, does not affect aspect or functionality

## Push button

### Flat profile

View	Description	Data	Code number		
			Color	Use with all except for PWH	Use with PWH base only
	Action	Momentary	Black	B1A	B1H
	Type	Single pole, NO	Red	R1A	R1H
	Current rating	30 Vdc/50 mA	Yellow	Y1A	Y1H
	Connection in base	Use 1 function	Gray	G1A	G1H
	Mechanical life	1 million cycles	Green	L1A	L1H
	Operating force	1 to 2.5 N (100 to 250 g)	Blue	W1A	W1H
	Ingress protection, IP rating	IP 66	White	H1A	H1H
	Operating temperature	-30°C to 60°C (-22°F to 140°F)			

### Dome shape

View	Description	Data	Code number		
			Color	Use with all except for PWH	Use with PWH base only
	Action	Momentary	Yellow	11A	11H
	Type	SPST-NO-DB	Black	21A	21H
	Current rating	30 Vdc/50 mA	Green	31A	31H
	Connection in base	Use 1 function	Red	41A	41H
	Mechanical life	1 million cycles	Blue	51A	51H
	Operating force	Nominal 3 N (306 g)	White	61A	61H
	Ingress protection, IP rating	IP 66			
	Operating temperature	-40°C to +85°C C (-40°F to 185°F)			

## Roller



Roller—5mm (use only on the faceplate except for HR1, HP1, PR7, PP7 grips)

View	Description	Data	Code number	
			Use with all except for PWH	Use with PWH base only
	Action	Spring return to neutral	P1A	P1H
	Output	Max. voltage: 30 Vdc		
		Proportional signal: 25% - 50% - 75%		
		Impedance: 5 kΩ ±50%		
	Signal: 15 uA (1 mA peak)			

*Roller—5mm (use only on the faceplate except for HR1, HP1, PR7, PP7 grips) (continued)*

View	Description	Data	Code number	
			Use with all except for PWH	Use with PWH base only
	Direction switches	30 Vdc/2 mA	S1A	S1H
	Working angle	±42°		
	Mechanical life	3 million cycles		
	Ingress protection (IP) rating	IP 43		
	Operating temperature	-30°C to 60°C (-22°F to 140°F)		

*Roller—3mm (use only on the grip and HR1, HP1, PR7, PP7 faceplate)*

View	Description	Data	Code number	
			Use with all except for PWH	Use with PWH base only
	Action	Spring return to neutral	U1A	U1H
	Output	Maximum voltage: 30 Vdc		
		Proportional signal: 25% - 50% - 75%		
		Impedance: 5 kΩ ±50%		
Signal: 15 uA (1mA peak)				
	Direction switches	30 Vdc/2 mA	Q1A	Q1H
	Working angle	±42°		
	Mechanical life	3 million cycles		
	Ingress protection (IP) rating	IP 43		
	Operating temperature	-30°C to 60°C (-22°F to 140°F)		

*Hall Roller - 5mm (use only on the faceplate except for HR1, HP1, PR7, PP7 grips)*

View	Description	Data	Code number	
			Use with all except for PWH	Use with PWH base only
	Action	Proportional spring return to center	V1A V3A (redundant)	V1H
	Working angle	±42°		
	Sensing	Hall effect		
	CAN electrical output	±0 to 1000 counts from center		
	Analog electrical output	0.5 to 4.5 Vdc (2.5 Vdc center)		
	Mechanical life	3 million cycles		
	Ingress protection (IP) rating	Electrical shielding IP66		
	Operating temperature	-30°C to 60°C (-22°F to 140°F)		

*Hall Roller - 3mm (use only on the faceplate except for HR1, HP1, PR7, PP7 grips)*

View	Description	Data	Code number	
			Use with all except for PWH	Use with PWH base only
	Action	Proportional spring return to center	V2A V4A (redundant)	V1H
	Working angle	±42°		
	Sensing	Hall effect		
	CAN electrical output	±0 to 1000 counts from center		
	Analog electrical output	0.5 to 4.5 Vdc (2.5 Vdc center)		
	Mechanical life	3 million cycles		
	Ingress protection (IP) rating	Electrical shielding IP66		
	Operating temperature	-30°C to 60°C (-22°F to 140°F)		

**FNR**



*Black*

View	Description	Data	Code number	
			Use with all except for PWH	Use with PWH base only
	Action	3-position maintained	F1A	F1H
	Type	Single pole, NC - NO - NC	K3A K4A	
	Contact rating	30 Vdc/50 mA		
	Connection in base	Use 2 functions		
	Mechanical life	1 million cycles		
	Ingress protection, IP rating	IP 40		
	Operating temperature	-30°C to 60°C (-22°F to 140°F)		

*IP 66 Rocker*

View	Description	Data	Code number	
			Use with all except for PWH	Use with PWH base only
	Action	3-position maintained	M1A	M1A
	Type	Single pole, NC - NO - NC		
	Contact rating	30 Vdc/50 mA		
	Connection in base	Use 2 functions		
	Mechanical life	1 million cycles		
	Ingress protection, IP rating	IP 66		
	Operating temperature	-30°C to 60°C (-22°F to 140°F)		

*Red, Orange*

View	Description	Data	Code number	
			Use with all except for PWH	Use with PWH base only
	Action	3-position maintained	K1A	K1H
	Type	Single pole, NC - NO - NC		
	Contact rating	30 Vdc/50 mA		
	Connection in base	Use 2 functions		
	Mechanical life	1 million cycles		
	Ingress protection, IP rating	IP 66		
	Operating temperature	-30°C to 60°C (-22°F to 140°F)		
			K3A	K4A

Toggle switch

*IP 66 Black*

View	Description	Data	Code number	
			Use with all except for PWH	Use with PWH base only
	Action	2-position maintained	M7A	M7H
	Type	Single pole, NO and NC & NC - NO - NC		
	Contact rating	30 Vdc/50mA		
	Connection in base	Use 2 functions		
	Mechanical life	1 million cycles		
	Ingress protection, IP rating	IP 66		
	Operating temperature	-30°C to 60°C (-22°F to 140°F)		

*Rocker*

View	Description	Data	Code number	
			Use with all except for PWH	Use with PWH base only
	Action	2-position maintained	T1A	T1H
	Type	Single pole, NO and NC output		
	Contact rating	30 Vdc/50 mA		
	Connection in base	Use 2 functions		
	Mechanical life	1 million cycles		
	Ingress protection, IP rating	IP 40		
	Operating temperature	-30°C to 60°C (-22°F to 140°F)		

## Operator Presence switch

### Operator Presence switch\*

View	Description	Data	Code number	
			Use with all except for PWH	Use with PWH base only
	Action	Momentary	O1A	O1H
	Type	Single pole, NO		
	Contact rating	10 mA, 12 Vdc resistive		
	Connection in base	Use 1 function		
	Mechanical life	1 million cycles		
	Ingress protection, IP rating	IP 66		
	Operating temperature	-40° C to +85° C (-40° F to 185° F)		

### Operator Presence switch (HR1, HP1 grip only)

View	Description	Data	Code number	
			Use with all except for PWH	Use with PWH base only
	Action	Momentary	O2A	O2H
	Type	Single pole, NO		
	Contact rating	10 mA, 12 Vdc resistive		
	Connection in base	Use 1 function		
	Mechanical life	1 million cycles		
	Ingress protection, IP rating	IP 66		
	Operating temperature	-40° C to +85° C (-40° F to 185° F)		

### Operator Presence switch (PR7, PPR grip only)

View	Description	Data	Code number	
			Use with all except for PWH	Use with PWH base only
	Action	Momentary	A1A (left) E1A (right)	A1H (left) E1H (right)
	Type	Single pole, NO		
	Contact rating	30 Vdc, 50 mA		
	Connection in base	Use 1 function		
	Mechanical life	1 million cycles		
	Ingress protection, IP rating	IP 66		
	Operating temperature	-40° C to 85° C (-40° F to 185° F)		

\*In order to ensure the full and correct engagement of the OPS button, Danfoss recommends applying the force to the center of the OPS lever.

## Connector options and cabling

### One 6 pin connector

 **Note**

Used only with CAN base.

*Cabling and pin location: One 6 pin DEUTSCH DTM04 connector*

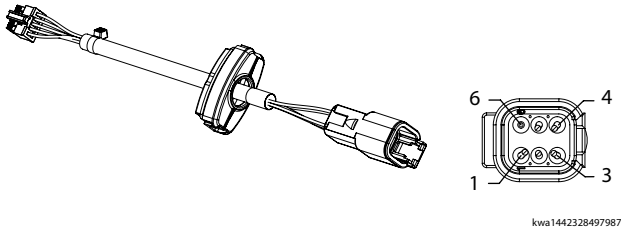

#### One 6 pin pinout

DEUTSCH DTM04 6 pin	Function
1	Ground
2	Power
3	CAN high
4	CAN low
5	CAN shield
6	NC

## Two 6 pin connectors



**Note**

Used only in CAN base.

Cabling and pin location: Two 6 pin DEUTSCH DTM04 connectors

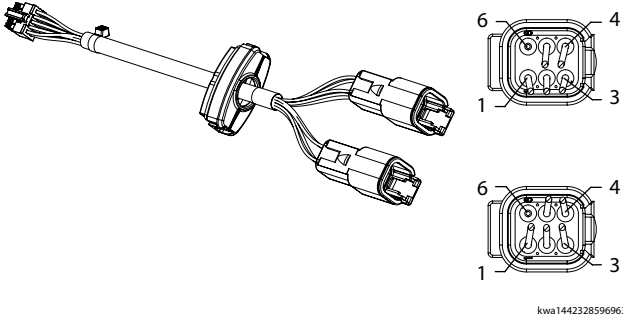

Two 6 pin pinout

DEUTSCH DTM04 6 pin	DEUTSCH DTM04 6 pin	Function
1		Ground
2		Power
3		CAN high
4		CAN low
5		CAN shield
6		NC
	1	Ground
	2	Power
	3	CAN high
	4	CAN low
	5	CAN shield
	6	NC

## Two 12 pin connectors

Used only on CANalog, CAN+, PVE, Analog Cat 1, and Analog Cat 3 Standard base.

Cabling and pin location: Two 12 pin DEUTSCH DTM04 connectors

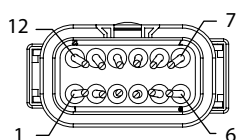
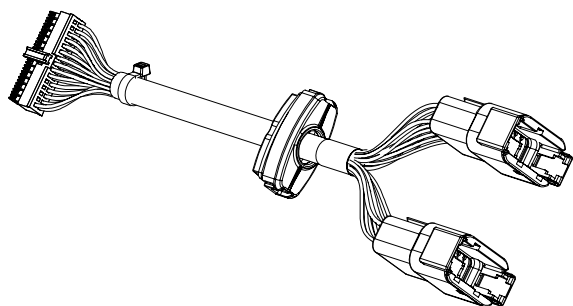

**A**

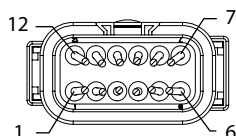

**B**

Standard, 12 pin A pinout (Gray)

DEUTSCH DTM04 12 PIN	PVE Standard	CANalog	CAN+	Analog Cat 1	Analog Cat 3	PWM
1	GND	GND	GND	GND	GND_ANA1	GND 1
2	PWR	PWR	PWR	PWR_ANA	PWR_ANA1 (+5V only)	PWR 1
3	CAN high	CAN high	CAN high	Y1 (Prop 1)	Y1 (Prop 1)	CAN high
4	CAN low	CAN low	CAN low	X1 (Prop 2)	X1 (Prop 2)	CAN lo
5	CAN shield	CAN shield	CAN shield	Analog 3A	Analog 3A	CAN shield
6	Proportional X	NC	NC	Analog 4A	Analog 4A	GND 2
7	Proportional Y	Grip analog 3a	A/D 1	Button 1	Button 1	PWR 2
8	Proportional 3	Grip analog 3b	A/D 2	Button 2	Button 2	PWR 3
9	Push 7	Reference ground	Sensor ground	Button 3	Button 3	PWR 4
10	Push 8	5V reference	Sensor power	Button 4	Button 4	Not used
11	PVE power (neutral switch)	Grip analog 1a	A/D 3	PWR_ANA	PWR_ANA2 (+5V Only)	NC
12	PVE power feedback	Grip analog 1b	A/D	GND	GND_ANA2	NC

Standard, 12 pin B pinout (Black)

DEUTSCH DTM04 12 PIN	PVE Standard	CANalog	CAN+	Analog Cat 1	Analog Cat 3	PWM
1	Direction Xa	NC	Digital input 7	NC	NC	PWM X+
2	Direction Xb	NC	NC	NC	NC	PWM X-
3	Direction Ya	NC	NC	Y2	Y2	PWM Y+
4	Direction Yb	NC	NC	X2	X2	PWM Y-
5	Direction 3a/ Push 1	NC	NC	Analog 3B	Analog 3B	NC
6	Direction 3b/ Push 2	NC	NC	Analog 4B	Analog 4B	NC

Standard, 12 pin B pinout (Black) (continued)

DEUTSCH DTM04 12 PIN	PVE Standard	CANalog	CAN+	Analog Cat 1	Analog Cat 3	PWM
7	Proportional 4	Grip analog 2a	Digital input 1	Button 5	Button 5	Dig Out 1
8	Direction 4a/ Push 3	Grip analog 2b	Digital input 2	Button 6	Button 6	Dig Out 2
9	Direction 4b/ Push 4	Y1	Digital input 3	Button 7	Button 7	Not used
10	Proportional 5	X1	Digital input 4	Button 8 / OPS	Button 8 / OPS	Not used
11	Direction 5a/ Push 5	Y2	Digital input 5	Analog 5A	Analog 5A	Not used
12	Direction 5b/ Push 6	X2	Digital input 6	Analog 5B	Analog 5B	Not used

When using PWM base, make sure that all Power and Ground pins have connections to avoid an over current occurrence from happening.

Two 12 pin and one 6 pin connectors

Used only on PVE Extended base.

Cabling and pin location: Two 12 pin and one 6 pin DEUTSCH DTM04 connectors

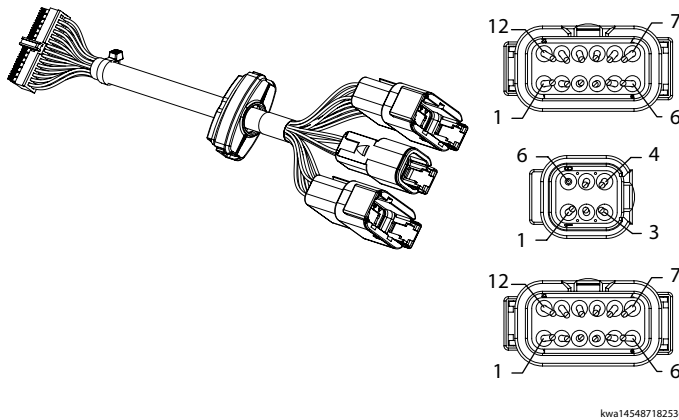

kwa1454871825360

Extended, 12 pin A pinout (Gray)

DEUTSCH DTM04 12 PIN	PVE Extended	Analog Cat 1	Analog Cat 3
1	Ground	GND	GND_ANA1
2	Power	PWR_ANA	PWR_ANA1 (+5V only)
3	CAN high	Y1 (Prop 1)	Y1 (Prop 1)
4	CAN low	X1 (Prop 2)	X1 (Prop 2)
5	CAN shield	Analog 3A	Analog 3A
6	Proportional X	Analog 4A	Analog 4A
7	Proportional Y	Button 1	Button 1
8	Proportional 3	Button 2	Button 2
9	Push 7	Button 3	Button 3
10	Push 8	Button 4	Button 4
11	PVE power (neutral switch)	PWR_ANA	PWR_ANA2 (+5V Only)
12	PVE power feedback	GND	GND_ANA2

Extended, 12 pin B pinout (Black)

DEUTSCH DTM04 12 PIN	PVE Extended	Analog Cat 1	Analog Cat 3
1	Direction Xa	NC	NC
2	Direction Xb	NC	NC
3	Direction Ya	Y2	Y2

*Extended, 12 pin B pinout (Black) (continued)*

DEUTSCH DTM04 12 PIN	PVE Extended	Analog Cat 1	Analog Cat 3
4	Direction Yb	X2	X2
5	Direction 3A/Push 1	Analog 3B	Analog 3B
6	Direction 3B/Push 2	Analog 4B	Analog 4B
7	Proportional 4	Button 5	Button 5
8	Direction 4A/Push 3	Button 6	Button 6
9	Direction 4B/Push 4	Button 7	Button 7
10	Proportional 5	Button 8 / OPS	Button 8 / OPS
11	Direction 5A/Push 5	Analog 5A	Analog 5A
12	Direction 5B/Push 6	Analog 5B	Analog 5B

*Extended, 6 pin pinout*

DEUTSCH DTM04 6-pin	PVE	Analog Cat 1	Analog Cat 3
1	Power	Button 9	Button 9
2	Push 9	Button 10	Button 10
3	Push 10	Button 11	Button 11
4	Push 11	Button 12	Button 12
5	Push 12	open	open
6	NC	NC	NC

**One 18 pin connector**

Used only on CAN+ or CANalog base.

*Cabling and pin location: One 18 pin DEUTSCH connector (DT16-18SB-K004)*

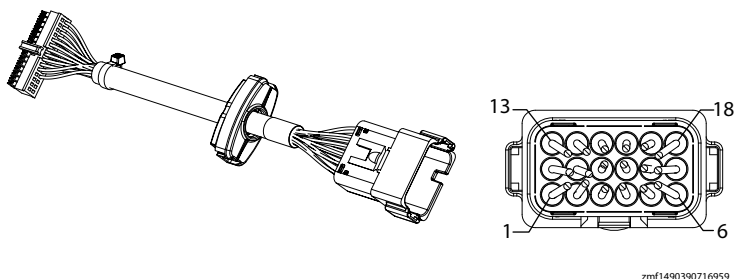

*18 pin pinout*

DEUTSCH 18 pin	CAN+ function	CANalog function	Analog Function
1	Ground	Ground	GND
2	Power	Power	PWR
3	CAN Hi	CAN Hi	Prop 3
4	CAN Lo	CAN Lo	Prop 4
5	CAN Shield	CAN Shield	Prop 5
6	Digital input 7	Not connected	NC
7	Vref ground	Reference ground	Dig In 1
8	Vref +5V	Reference +5V	Dig In 2
9	Analog in 1	Grip analog 3a	Dig In 3
10	Analog in 2	Grip analog 3b	Dig In 4
11	Analog in 3	Grip analog 1a	Dig In 5
12	Analog in 4	Grip analog 2a	Dig In 6
13	Digital input 1	Grip analog 1b	Dig In 7

*18 pin pinout (continued)*

DEUTSCH 18 pin	CAN+ function	CANalog function	Analog Function
14	Digital input 2	Grip analog 2b	Dig In 8
15	Digital input 3	Proportional Y-axis 1	Y1 (Prop 1)
16	Digital input 4	Proportional X-axis 1	X1 (Prop 2)
17	Digital input 5	Proportional Y-axis 2	Y2 (Prop 1)
18	Digital input 6	Proportional X-axis 2	X1 (Prop 2)

## One 25 pin SUB-D and one 6 pin connectors



### Note

Used only on PVE base, with PP2, PR2, STT, and STP grips as Prof 1 replacements.

Cabling and pin location: One 25 pin SUB-D and one 6 pin DEUTSCH DTM04 connectors; Code number: 11173403-T

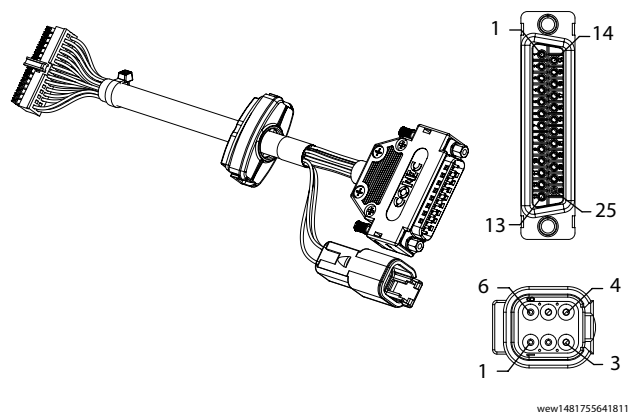

### 25 pin SUB-D pinout

25 pin SUB-D	Function
1	PVE power (neutral switch)
2	PVE power (neutral switch)
3	Power
4	Direction 5a/Push 5
5	Proportional 3
6	Direction 3a/Push 1
7	Proportional X
8	Proportional Y
9	Direction Ya
10	PVE Power feedback
11	Direction Xb
12	Push 8
13	Push 7
14	PVE power (neutral switch)
15	Power
16	Power
17	Direction 5b/ Push 6
18	Proportional 4
19	Direction 3b/Push 2
20	Direction 4a/Push 3
21	Direction 4b/Push 4
22	Ground
23	Direction Yb
24	Direction Xa
25	NC

### 6 pin DEUTSCH DTM04 pinout

6 pin DEUTSCH DTM04	Function
1	NC
2	NC

6 pin DEUTSCH DTM04 pinout (continued)

6 pin DEUTSCH DTM04	Function
3	CAN high
4	CAN low
5	CAN shield
6	NC

Mating connectors bag assemblies

Danfoss connector bag assemblies part numbers (Must be ordered separately from joystick)

Description	Danfoss part number
One 6 pin DEUTSCH connector	10101551
Two 6 pin DEUTSCH connectors	11177980
Two 12 pin DEUTSCH connectors (GRY/BLK)	10100945
Two 12 pin (GRY/BLK) and One 6 pin DEUTSCH connectors	11176538
One 18 pin DEUTSCH connector	11012648

DEUTSCH mating connector bag assemblies contents

Description	6 pin module	12 pin module (GRY)	12 pin module (BLK)
Crimp tool	HDT-48-00	HDT-48-00	HDT-48-00
Contacts	0462-201-2031	0462-201-2031	0462-201-2031
Connector plug	DTM06-6S,GRY	DTMO6-12SA, GRY	DTMO6-12SB, BLK
Wedge	WM-6S	WM-12S	WM-12S
Strip length	3.96 to 5.54 mm (0.156 to 0.218 in)	3.96 to 5.54 mm (0.156 to 0.218 in)	3.96 to 5.54 mm (0.156 to 0.218 in)
Rear seal maximum insulation OD	3.05 mm (0.120 in)	3.05 mm (0.120 in)	3.05 mm (0.120 in)
Sealing plugs	0413-204-2005	0413-204-2005	0413-204-2005

## Cable assemblies

All cable assemblies for JS1-H are 219 mm from the bottom of the case to the end of the connector.

*JS1-H cable length in millimeters*

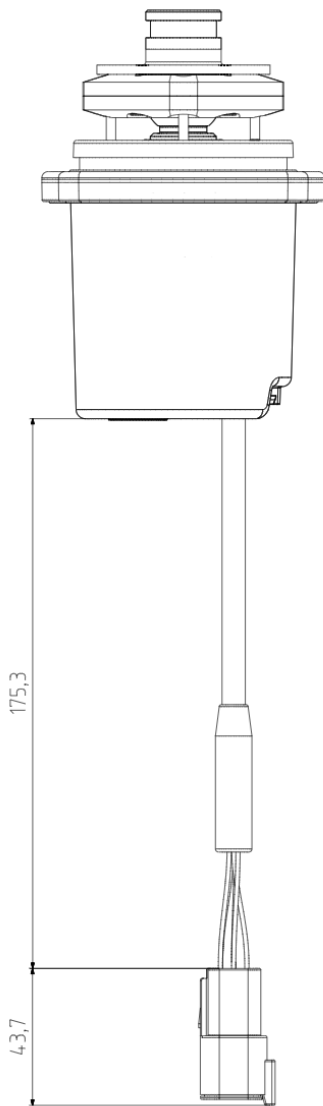

### 1. DEUTSCH DTM04 receptacle

*Compatible mating cables available for different applications*

Code no. 162B....	Length mm	Plug type	Type
6013	4000	Leads	Vertical SUB-D
6014	4000	Leads	Horizontal SUB-D
6015	500	Clipper	–
6016	230	TRIM TRIO	–
6017	230	Tabs	PVRE compatibility

*Cable assemblies - first is vertical view, followed by horizontal views*

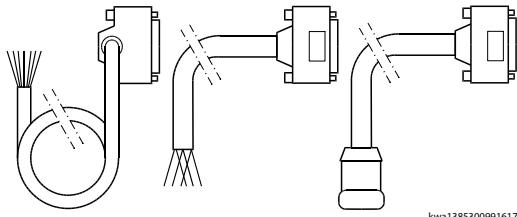

kwa1385300991617

## Product configuration model code

The product configuration model code specifies particular features when ordering the JS1-H. The model code begins with the product family name and the remaining fields are filled in to configure the product with the desired features.

## JS1-H base and grip model code fields

The configuration model code contains information relating to both base and grip features.

*JS1-H Joystick product configuration model code*

Family	Base						Grip														Other				
A	B	C	D	E	F1	F2	G	H1	H2	H3	H4	H5	H6	H7	H8	H9	H10	H11	H12	J1	J2	J3	J4	K	
JS1H																									

## JS1-H Base model code

### JS1-H Joystick product configuration model code

Family		Base						Grip														Other			
A	B	C	D	E	F1	F2	G	H1	H2	H3	H4	H5	H6	H7	H8	H9	H10	H11	H12	J1	J2	J3	J4	K	
JS1H																									

#### A—Product family

Code	Description
JS1H	Family name

#### B—Operational axis

Code	Description
NN	No base
XY	Bi-directional: X and Y-axis
NY	Uni-directional: Only Y-axis
XN	Uni-directional: Only X-axis
NF	Single Axis: Frictional Y-axis
XF	Bi-directional: X Spring Return, Y Frictional
FN	Single Axis: Frictional X-axis

#### C—Shaft position, sensing output

Code	Description
NNN	No base
NN2	No base, no connectors on wires
CJP	CAN J1939 with potentiometer
CJH	CAN J1939 with Hall effect
CPP	CANopen with potentiometer
CPH	CANopen with Hall effect
CSP	CAN Analog, J1939 with potentiometer
CSH	CAN Analog, J1939 with Hall effect
CTP	CAN Analog, Open with potentiometer
CTH	CAN Analog, Open with Hall effect
CLP	CAN+ J1939 with potentiometer
CLH	CAN+ J1939 with Hall effect
CMP	CAN+ Open with potentiometer
CMH	CAN+ Open with Hall effect
PSP	PVE Standard base with potentiometer
PSH	PVE Standard base with Hall effect
PEH	PVE Extended base with Hall effect
PEP	PVE Extended base with potentiometer
PBH	Analog Category 1 with Hall effect
PRH	Analog Category 3 with Hall effect
PWH	PLUS+1° GUIDE Programmable PWM, Hall effect
P2H	PLUS+1° GUIDE Programmable PVE, Hall effect

#### D—Centering spring

Code	Description
N	No base
S	Standard spring force

Code	Description
H	Heavy spring force
A	Friction 0.8 Nm, Center 1.5 Nm
B	Friction 0.8 Nm, Center 2.0 Nm
C	Friction 1.6 Nm, Center 3.0 Nm
M	Extra Heavy spring force

The following table only applies when using XF base.

Code	Description
E	Friction 0.8 Nm, Center 1.5 Nm, Standard spring force
J	Friction 0.8 Nm, Center 1.5 Nm, Heavy spring force

***E—CAN***

Code	Description
NNN	Analog (base and/or grip)
C10	Node ID 10, 250kbps
C13	Node ID 13, 250kbps
C16	Node ID 16, 250kbps
C33	Node ID 33, 250kbps
C34	Node ID 34, 250kbps
C35	Node ID 35, 250kbps
C36	Node ID 36, 250kbps
D33	Node ID 33, 500kbps
D34	Node ID 34, 500kbps
D35	Node ID 35, 500kbps
D36	Node ID 36, 500kbps
D90	Node ID 90, 500kbps
D93	Node ID 93, 500kbps
D96	Node ID 96, 500kbps
D9C	Node ID 9C, 500kbps
C90	Node ID 90, 250kbps
C93	Node ID 93, 250kbps
C96	Node ID 96, 250kbps
C9C	Node ID 9C, 250kbps
B10	Node ID 10, 125kbps
B13	Node ID 13, 125kbps
B16	Node ID 16, 125kbps
B1C	Node ID 1C, 125kbps
C1C	Node ID 1C, 250kbps
C71	Replace of NodeID: N71
C72	Replace of NodeID: N72

***F1—Mounting***

Code	Description
N	No base
T	Top mount with NBR boot
D	Top mount with EPDM boot

## Grip model code

### JS1-H Joystick product configuration model code

Family		Base						Grip														Other			
A	B	C	D	E	F1	F2	G	H1	H2	H3	H4	H5	H6	H7	H8	H9	H10	H11	H12	J1	J2	J3	J4	K	
JS1H																									

#### F2—Grip type

Code	Description
HR1	Horizontal grip
HP1	IP 66 version of HR1
ST2	Medium straight grip
SP2	IP 66 version of ST2
PR2	Prof1 version 2 grip
PP2	IP 66 version of PR2
ST7	Large straight grip
SP7	IP 66 version of ST7
PR7	Professional JS7000 grip
PP7	IP 66 version PR7
NNN	Base only solution

IP66 rating only applicable to full joystick configurations.

Select the grip that meets the needs of your application.

Grip only solution in selected regions.

#### G—Left or right hand or ambidextrous

Code	Description
L	Left hand grip
R	Right hand grip
U	Ambidextrous grip (accommodates left and right hand)

Select the grip that meets the needs of your application.

#### H1—Defining of front plate

Code		Description
Use with all bases except for PWH	Use with PWH base only	
NNN	NNN	No button
B1A	B1H	Black push button
R1A	R1H	Red push button
Y1A	Y1H	Yellow push button
G1A	G1H	Gray push button
L1A	L1H	Green push button
W1A	W1H	Blue push button
H1A	H1H	White push button
11A	11H	Yellow push button - Dome Shape
21A	21H	Black push button - Dome Shape
31A	31H	Green push button - Dome Shape
41A	41H	Red push button - Dome Shape
51A	51H	Blue push button - Dome Shape
61A	61H	White push button - Dome Shape
P1A	P1H	Roller, [position 1-2]

H1—Defining of front plate (continued)

Code		Description
Use with all bases except for PWH	Use with PWH base only	
S1A	S1H	Roller v-Lead, [position 1-2]
V1A	V1H	IP 66 Roller, [position 1-2]
F1A	F1H	FNR [Black], [position 1-2]
T1A	T1H	Toggle [Rocker], [position 1-2]
K1A	K1H	FNR [Red], [position 1-2]
K3A	-	FNR [Orange with print], [position 1-2]
K4A	-	FNR [Orange with print], [position 1-2]
V3A	-	IP66 Roller (redundant), [position 1-2]
M1A	M1H	IP66 FNR [Black], [position 1-2]
M7A	M7H	IP66 Toggle [Rocker], [position 1-2]

H2—Defining of front plate

Code		Description
Use with all bases except for PWH	Use with PWH base only	
NNN	NNN	No button
B1A	B1H	Black push button
R1A	R1H	Red push button
Y1A	Y1H	Yellow push button
G1A	G1H	Gray push button
L1A	L1H	Green push button
W1A	W1H	Blue push button
H1A	H1H	White push button
11A	11H	Yellow push button - Dome Shape
21A	21H	Black push button - Dome Shape
31A	31H	Green push button - Dome Shape
41A	41H	Red push button - Dome Shape
51A	51H	Blue push button - Dome Shape
61A	61H	White push button - Dome Shape
P1A	P1H	Roller, [position 2-3]
S1A	S1H	Roller v-Lead, [position 2-3]
V1A	V1H	IP 66 Roller, [position 2-3]
F1A	F1H	FNR [Black], [position 2-3]
V3A	-	IP66 Roller (Redundant), [position 2-3]
M1A	M1H	IP66 FNR [Black], [position 2-3]
M7A	M7H	IP66 Toggle [Rocker], [position 2-3]
T1A	T1H	Toggle [Black], [position 2-3]
K1A	K1H	FNR [Red], [position 2-3]
K3A	-	FNR [Orange with print], [position_]
K4A	-	FNR [Orange with print], [position_]
+++	+++	Customer refer to <i>ST2—Faceplate options</i> on page 14 and <i>ST7—Faceplate options</i> on page 21

H3—Defining of front plate

Code		Description
Use with all bases except for PWH	Use with PWH base only	
NNN	NNN	No button
B1A	B1H	Black push button
R1A	R1H	Red push button
Y1A	Y1H	Yellow push button
G1A	G1H	Gray push button
L1A	L1H	Green push button
W1A	W1H	Blue push button
H1A	H1H	White push button
11A	11H	Yellow push button - Dome Shape
21A	21H	Black push button - Dome Shape
31A	31H	Green push button - Dome Shape
41A	41H	Red push button - Dome Shape
51A	51H	Blue push button - Dome Shape
61A	61H	White push button - Dome Shape
P1A	P1H	Roller, [position 3-4]
S1A	S1H	Roller v-Lead, [position 3-4]
V1A	V1H	IP 66 Roller, [position 3-4]
F1A	F1H	FNR [Black], [position 3-4]
V3A	-	IP66 Roller (redundant), [position 3-4]
M1A	M1H	IP66 FNR [Black], [position 3-4]
M7A	M7H	IP66 Toggle [Rocker], [position 3-4]
T1A	T1H	Toggle [Black], [position 3-4]
K1A	K1H	FNR [Red], [position 3-4]
K3A	-	FNR [Orange with print], [position_]
K4A	-	FNR [Orange with print], [position_]
+++	+++	Customer refer to <i>ST2—Faceplate options</i> on page 14 and <i>ST7—Faceplate options</i> on page 21

H4—Defining of front plate

Code		Description
Use with all bases except for PWH	Use with PWH base only	
NNN	NNN	No button
B1A	B1H	Black push button
R1A	R1H	Red push button
Y1A	Y1H	Yellow push button
G1A	G1H	Gray push button
L1A	L1H	Green push button
W1A	W1H	Blue push button
H1A	H1H	White push button
11A	11H	Yellow push button - Dome Shape
21A	21H	Black push button - Dome Shape
31A	31H	Green push button - Dome Shape
41A	41H	Red push button - Dome Shape
51A	51H	Blue push button - Dome Shape
61A	61H	White push button - Dome Shape

H4—Defining of front plate (continued)

Code		Description
Use with all bases except for PWH	Use with PWH base only	
P1A	P1H	Roller, [position 4-1]
S1A	S1H	Roller v-Lead, [position 4-1]
V1A	V1H	IP 66 Roller, [position 4-1]
F1A	F1H	FNR [Black], [position 4-1]
V3A	-	IP66 Roller (redundant)
M1A	M1H	IP66 FNR [Black], [position 4-1]
M7A	M7H	Toggle [Rocker], [position 4-1]
T1A	T1H	Toggle [Black], [position 4-1]
K1A	K1H	FNR [Red], [position 4-1]
K3A	-	FNR [Orange with print], [position_]
K4A	-	FNR [Orange with print], [position_]
+++	+++	Customer refer to <i>ST2—Faceplate options</i> on page 14 and <i>ST7—Faceplate options</i> on page 21

H5—Defining of front plate

Code		Description
Use with all bases except for PWH	Use with PWH base only	
NNN	NNN	No button
B1A	B1H	Black push button
R1A	R1H	Red push button
Y1A	Y1H	Yellow push button
G1A	G1H	Gray push button
L1A	L1H	Green push button
W1A	W1H	Blue push button
H1A	H1H	White push button
11A	11H	Yellow push button - Dome Shape
21A	21H	Black push button - Dome Shape
31A	31H	Green push button - Dome Shape
41A	41H	Red push button - Dome Shape
51A	51H	Blue push button - Dome Shape
61A	61H	White push button - Dome Shape
+++	+++	Customer refer to <i>ST2—Faceplate options</i> on page 14 and <i>ST7—Faceplate options</i> on page 21

H6—Defining grip side

Code		Description
Use with all bases except for PWH	Use with PWH base only	
NNN	NNN	No button
B1A	B1H	Black push button
R1A	R1H	Red push button
Y1A	Y1H	Yellow push button
G1A	G1H	Gray push button
L1A	L1H	Green push button
W1A	W1H	Blue push button

H6—Defining grip side (continued)

Code		Description
Use with all bases except for PWH	Use with PWH base only	
H1A	H1H	White push button
11A	11H	Yellow push button - Dome Shape
21A	21H	Black push button - Dome Shape
31A	31H	Green push button - Dome Shape
41A	41H	Red push button - Dome Shape
51A	51H	Blue push button - Dome Shape
61A	61H	White push button - Dome Shape
P1A	P1H	Roller, [position 6-12]
S1A	S1H	Roller v-Lead, [position 6-12]
V1A	V1H	IP 66 Roller, [position 6-12]
F1A	F1H	FNR [Black], [position 6-12]
V3A	-	IP66 Roller (redundant)
M1A	M1H	IP66 FNR [Black], [position 6-12]
M7A	M7H	IP66 Toggle [Rocker], [position 6-12]
T1A	T1H	Toggle [Black], [position 6-12]
K1A	K1H	FNR [Red], [position 6-12]
K3A	-	FNR [Orange with print], [position _]
K4A	-	FNR [Orange with print], [position _]
+++	+++	Customer refer to <i>ST2—Faceplate options</i> on page 14 and <i>ST7—Faceplate options</i> on page 21

H7—Defining grip side

Code		Description
Use with all bases except for PWH	Use with PWH base only	
NNN	NNN	No button
B1A	B	Black push button
R1A	R1H	Red push button
Y1A	Y1H	Yellow push button
G1A	G1H	Gray push button
L1A	L1H	Green push button
W1A	W1H	Blue push button
H1A	H1H	White push button
11A	11H	Yellow push button - Dome Shape
21A	21H	Black push button - Dome Shape
31A	31H	Green push button - Dome Shape
41A	41H	Red push button - Dome Shape
51A	51H	Blue push button - Dome Shape
61A	61H	White push button - Dome Shape
D1A	D1H	Square Push Button - OPS (obsolete)
O1A	O1H	Operator Presence Switch (PR2 and PP2 grips only)
U1A	U1H	Roller, [position 7-8]
Q1A	Q1H	Roller v-Lead, [position 7-8]
V1A	V1H	IP 66 Roller, [position 7-8]
V4A	-	IP 66 Roller (redundant)

*H7—Defining grip side (continued)*

Code		Description
Use with all bases except for PWH	Use with PWH base only	
M1A	M1H	IP 66 FNR [Black], [positioin 7-8
M7A	M7H	IP 66 Toggle [Rocker], [position 7-8]

*H8—Defining grip side*

Code		Description
Use with all bases except for PWH	Use with PWH base only	
NNN	NNN	No button
B1A	B1H	Black push button
R1A	R1H	Red push button
Y1A	Y1H	Yellow push button
G1A	G1H	Gray push button
L1A	L1H	Green push button
W1A	W1H	Blue push button
H1A	H1H	White push button
11A	11H	Yellow push button - Dome Shape
21A	21H	Black push button - Dome Shape
31A	31H	Green push button - Dome Shape
41A	41H	Red push button - Dome Shape
51A	51H	Blue push button - Dome Shape
61A	61H	White push button - Dome Shape
O1A	O1H	Operator Presence Switch (ST7, SP7, ST2, and SP2 grips only)
O2A	O2H	Operator Presence Switch(HR1 and HP1 grips only)
A1A	A1H	Operator Presence Switch (left hand PR7, PP7 grips only)
E1A	E1H	Operator Presence Switch (right hand PR7, PP7 grips only)

*H9—Defining of back side*

Code		Description
Use with all bases except for PWH	Use with PWH base only	
NNN	NNN	No button
B1A	B1H	Black push button
R1A	R1H	Red push button
Y1A	Y1H	Yellow push button
G1A	G1H	Gray push button
L1A	L1H	Green push button
W1A	W1H	Blue push button
H1A	H1H	White push button
11A	11H	Yellow push button - Dome Shape
21A	21H	Black push button - Dome Shape
31A	31H	Green push button - Dome Shape
41A	41H	Red push button - Dome Shape
51A	51H	Blue push button - Dome Shape
61A	61H	White push button - Dome Shape
K1A	K1H	FNR [Red], [position 9-10]

H9—Defining of back side (continued)

Code		Description
Use with all bases except for PWH	Use with PWH base only	
K3A	-	FNR [Orange with print], [position, _]
K4A	-	FNR [Orange with print], [position, _]

H10—Defining grip side

Code		Description
Use with all bases except for PWH	Use with PWH base only	
NNN	NNN	No button
B1A	B1H	Black push button
R1A	R1H	Red push button
Y1A	Y1H	Yellow push button
G1A	G1H	Gray push button
L1A	L1H	Green push button
W1A	W1H	Blue push button
H1A	H1H	White push button
11A	11H	Yellow push button - Dome Shape
21A	21H	Black push button - Dome Shape
31A	31H	Green push button - Dome Shape
41A	41H	Red push button - Dome Shape
51A	51H	Blue push button - Dome Shape
61A	61H	White push button - Dome Shape
F1A	F1H	FNR [Black], [position 10-11]
T1A	T1H	Toggle [Black], [position 10-11]
M1A	M1H	IP66 FNR [Black], [position 10-11]
M7A	M7H	IP66 Toggle [Rocker], [position 10-11]

H11—Defining grip side

Code		Description
Use with all bases except for PWH	Use with PWH base only	
NNN	NNN	No button
B1A	B1H	Black push button
R1A	R1H	Red push button
Y1A	Y1H	Yellow push button
G1A	G1H	Gray push button
L1A	L1H	Green push button
W1A	W1H	Blue push button
H1A	H1H	White push button
11A	11H	Yellow push button - Dome Shape
21A	21H	Black push button - Dome Shape
31A	31H	Green push button - Dome Shape
41A	41H	Red push button - Dome Shape
51A	51H	Blue push button - Dome Shape
61A	61H	White push button - Dome Shape

*H12—Defining grip side*

Code		Description
Use with all bases except for PWH	Use with PWH base only	
NNN	NNN	No button
B1A	B1H	Black push button
R1A	R1H	Red push button
Y1A	Y1H	Yellow push button
G1A	G1H	Gray push button
L1A	L1H	Green push button
W1A	W1H	Blue push button
H1A	H1H	White push button
11A	11H	Yellow push button - Dome Shape
21A	21H	Black push button - Dome Shape
31A	31H	Green push button - Dome Shape
41A	41H	Red push button - Dome Shape
51A	51H	Blue push button - Dome Shape
61A	61H	White push button - Dome Shape
K1A	K1H	FNR [Red], [position 12]
K3A	-	FNR [Orange with print], [position_]
K4A	-	FNR [Orange with print], [position_]
%%%	%%%	Assigned by factory when H10 has no restrictions for use. (ST7, SP7 grips only)
M1A	M1H	IP66 FNR [Black], [position 12]
M7A	M7H	IP66 Toggle [Rocker], [position 12]

*J1—Grip color*

Code	Description
N	No grip
G	HR1 and PR7 grip
B	ST2, ST7 and PR2 grip

*J2—Color band*

Code	Description
N	No color band
Y	Yellow color band
B	Black color band
R	Red color band

**Related reference**

### Other model code

#### JS1-H Joystick product configuration model code

Family		Base						Grip														Other			
A	B	C	D	E	F1	F2	G	H1	H2	H3	H4	H5	H6	H7	H8	H9	H10	H11	H12	J1	J2	J3	J4	K	
JS1H																									

#### J3—Cable

Code	Description
N	No cable
B	CAN+ cable with 1 x 12 pin DEUTSCH connector
G	CAN cable with 1 x 6 pin DEUTSCH connector
H	CAN cable with 2 x 6 pin DEUTSCH connector
J	CANalog cable with 18 pin DEUTSCH connector
L	PVE cable with 12+12+6 pin DEUTSCH connector
K	PVE cable with 12+12 pin DEUTSCH connector
T	PVE cable with SUB-D 25 + 6 pin DEUTSCH connector
Q	CAN+ cable with 18 pin DEUTSCH connector
W	PWM cable with 12+12 pin DEUTSCH connector
A	Analog cable with 18 pin DEUTSCH connector

#### J4—Kit and extension cable

Code	Description
N	No kit
B	Adapter Plate for JS7000
C	JS6000 bottom mount adapter

#### K—Software or settings

Code	Description
NN	No software or settings
J6	Used by factory to designate reverse roller operation on JS6000 replacements with horizontal rollers
MP	JS1-H & MP1P - Perfect Match
RO	Roller signal change
xx	Reserved for factory settings

## Product installation

### Joystick safety critical functions

For a system to operate safely it must be able to differentiate between commanded and uncommanded inputs. Take steps to detect and manage joystick and system failures that may cause an erroneous output.

For safety critical functions Danfoss recommends you use an independent momentary action system enable switch. You can incorporate this switch into the joystick as an operator presence switch or can be a separate foot or hand operated momentary switch. Disable all joystick functions that the joystick controls when this switch is released.

Ensure the control system looks for the appropriate system enable switch input before the joystick is displaced from its neutral position. Enable functions only after receiving this input.

Applications using CAN joysticks should continuously monitor for the presence of the CAN messages on periodic basis. Messages are to be checked frequently enough for the system or operator to react if the CAN messages lose priority or are no longer received.

### JS1 Heavy Duty Joystick critical mounting

JS1 Heavy Duty Joysticks are intended to be mounted in an upright position. Failure to mount properly could result in erroneous **Out of Neutral** signals.

*JS1-H mounted in upright position*

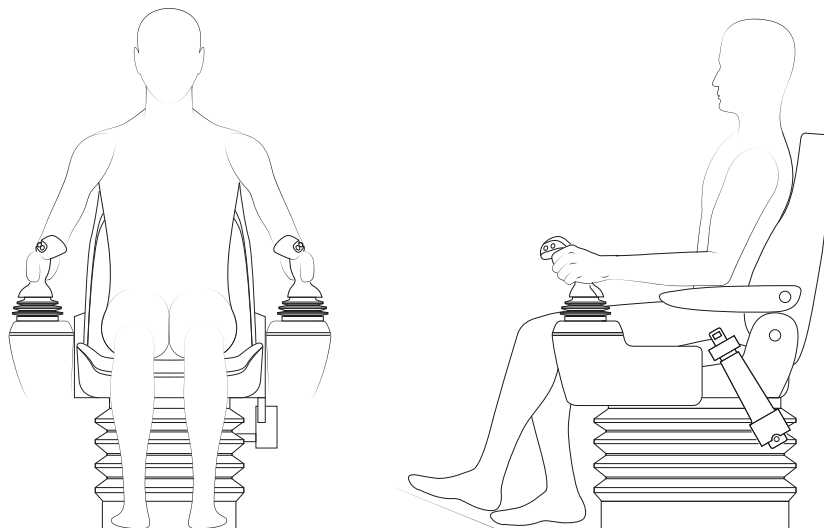

### Machine wiring guidelines

Use the following wiring guidelines.

#### **Warning**

Unintended movement of the machine or mechanism may cause injury to the technician or bystanders. Improperly protected power input lines against over current conditions may cause damage to the hardware. Properly protect all power input lines against over-current conditions. To protect against unintended movement, secure the machine.

#### **Caution**

Unused pins on mating connectors may cause intermittent product performance or premature failure. Plug all pins on mating connectors.

- Protect wires from mechanical abuse, run wires in flexible metal or plastic conduits.
- When using wire near hot surfaces, consider using 85° C (185° F) wire with abrasion resistant insulation and 105° C (221° F) wire.
- Use a wire size that is appropriate for the module connector.
- Separate high current wires such as solenoids, lights, alternators or fuel pumps from sensor and other noise-sensitive input wires.
- Run wires along the inside of, or close to, metal machine surfaces where possible. This simulates a shield which minimizes the effects of EMI/RFI radiation.
- Do not run wires near sharp metal corners, consider running wires through a grommet when rounding a corner.
- Do not run wires near hot machine members.
- Provide strain relief for all wires.
- Avoid running wires near moving or vibrating components.
- Avoid long, unsupported wire spans.
- Ground electronic modules to a dedicated conductor of sufficient size that is connected to the battery (-).
- Power the sensors and valve drive circuits by their dedicated wired power sources and ground returns.
- Twist sensor lines about one turn every 10 cm (4 in).
- Use wire harness anchors that allow wires to float with respect to the machine rather than rigid anchors.

## Appendix: CAN J1939 protocol

*Joysticks CAN J1939 protocol option* on page 75

*SAE J1939 basic joystick message* on page 76

*SAE J1939 extended joystick message* on page 81

*SAE J1939 error (DM1) messages* on page 82

## Joysticks CAN J1939 protocol option

Joysticks CAN J1939 protocol option designated as model code CAN and broadcast two J1939 messages to communicate the device information. The two messages are:

- Basic Joystick Message 1 (BJM1)
- Extended Joystick Message (EJM1)

## SAE J1939 basic joystick message

The JS1-H joystick uses the SAE J1939 basic joystick message to transfer information about the measured status of the X-axis and Y-axis of a joystick, the state of the switches on the joystick grip, and the state of external to the joystick digital inputs.

### Basic joystick message structure

Basic message number	Priority	Base parameter Group number (PGN)		Protocol Data Unit (PDU) format		PDU specific		Source address		Data field
		Dec	hex	Dec	hex	Dec	hex	Dec	hex	
1	3	64982	FDD6	253	FD	214	D6	*	*	8 bytes
3	3	64986	FDDA	253	FD	218	DA	*	*	8 bytes

\* Depends on position specified in master model code.

- Message transmission rate: 20 ms
- CAN bus baud rate: 250kbps

The resulting SAE J1939 basic joystick message PGN on the CAN bus is:

0xCFDD6 \*\_\* or 0xCFDDA \*\_\*

\* = joystick source address (hex)

### Data field

The data field contains the joystick's output information. SAE J1939 data fields contain 8 bytes of data.

#### Information in the data field

Byte#	0								1								2 and so on							
Bit#	1	2	3	4	5	6	7	8	1	2	3	4	5	6	7	8	1	2	3	4	5	6	7	8

## JS1-H Basic joystick message data field descriptions

### Basic joystick message parameters and data field locations

Start position (byte/bit)	Length (bits)	Parameter name
0/1	2	Joystick X-axis neutral position status
0/3	2	Joystick X-axis lever left negative position status
0/5	2	Joystick X-axis lever right positive position status
0/7 through 1/1-8	10	Joystick X-axis position (Byte 0 Bit 7 is LSB. Byte 1 Bit 8 is MSB)
2/1	2	Joystick Y-axis neutral position status
2/3	2	Joystick Y-axis lever back negative position
2/5	2	Joystick Y-axis lever forward positive position
2/7 through 3/1-8	10	Joystick Y-axis position (Byte 2 Bit 7 is LSB. Byte 3 Bit 8 is MSB)
4/5	2	Joystick Y-axis detent position status
4/7	2	Joystick X-axis detent position status
5/1	2	Grip button 4 pressed status
5/3	2	Grip button 3 pressed status
5/5	2	Grip button 2 pressed status
5/7	2	Grip button 1 pressed status
6/1	2	Grip button 8 pressed status
6/3	2	Grip button 7 pressed status
6/5	2	Grip button 6 pressed status
6/7	2	Grip button 5 pressed status
7/1	2	Grip button 12 pressed status
7/3	2	Grip button 11 pressed status
7/5	2	Grip button 10 presses status
7/7	2	Grip button 9 pressed status

### Data field example 1

<b>Byte</b>	0							
<b>Bit</b>	8	7	6	5	4	3	2	1
	The 2 LSB* of X-axis position status		X-axis lever right positive status		X-axis lever left negative position status		X-axis neutral position status	

\* Least Significant Bit.

### Data field example 2

<b>Byte</b>	1							
<b>Bit</b>	8	7	6	5	4	3	2	1
	MSB* X-axis position							

\* Most Significant Bit.

### Data field example 3

<b>Byte</b>	2							
<b>Bit</b>	8	7	6	5	4	3	2	1
	The 2 LSB* of X-axis position status		X-axis lever forward positive status		Y-axis lever back negative position status		Y-axis neutral position status	

\* Least Significant Bit.

**Joystick X-axis neutral position status**

Reports when the current joystick position is in the neutral position for the X-axis of travel.

*Information in the data field*

Bit status	Remarks
00	Not in neutral position
01	In neutral position
10	Error indicator
11	Not available

**Joystick X-axis handle left negative position status**

Reports when the current joystick position is on the negative travel side (back, left, counterclockwise, down) relative to the neutral position for the X-axis.

*Information in the Data Field*

Bit status	Remarks
00	Not on negative side of neutral
01	On negative side of neutral
10	Error indicator
11	Not available

**Joystick X-axis handle right positive position status**

Reports when the current joystick position is on the positive travel side (forward, right, clockwise, up) relative to the neutral position for the X-axis.

*Information in the data field*

Bit status	Remarks
00	Not on positive side of neutral
01	On positive side of neutral
10	Error indicator
11	Not available

**Joystick X-axis position status**

This is the position of the joystick in the relative motion of travel from the neutral position. The position value of 0 is always neutral. The output range of the joystick handle at the end of travel is factory set according to the option specified in the electrical interface options section of the master model code.

The master model code specifies that the full-scale output at the end of each linear zone will be 1000 counts.

 **Warning**

Potential uncommanded machine movement. Per the SAE J1939-71 standard:

- if the joystick internal diagnostics detect a shaft position measurement error, the joystick output will be set to a value of 1022 counts regardless of shaft position.
- if a specific joystick axis is not available, the basic joystick message for the unavailable axis will indicate an output value of 1023 counts.

Ensure application software recognizes these conditions to avoid the possibility of unintended machine motion.

**Joystick Y-axis neutral position status**

Reports when the current joystick position is in the neutral position for the Y-axis of travel.

*Information in the data field*

Bit status	Remarks
00	Not in neutral position
01	In neutral position
10	Error indicator
11	Not available

**Joystick Y-axis handle back negative position status**

Reports when the current joystick position is on the negative travel side (back, left, counterclockwise, down) relative to the neutral position for the Y-axis.

*Information in the data field*

Bit status	Remarks
00	Not on negative side of neutral
01	On negative side of neutral
10	Error indicator
11	Not available

**Joystick Y-axis handle forward positive position status**

Reports when the current joystick position is on the positive travel side (forward, right, clockwise, up) relative to the neutral position for the Y-axis.

*Information in the data field*

Bit status	Remarks
00	Not on positive side of neutral
01	On positive side of neutral
10	Error indicator
11	Not available

**Joystick Y-axis position status**

This is the position of the joystick in the relative motion of travel from the neutral position. The position value of 0 is always neutral. The output range of the joystick handle at the end of travel is factory set according to the option specified in the electrical interface options section of the master model code.

The master model code specifies that the full-scale output at the end of each linear zone will be 1000 counts.

 **Warning**

Potential uncommanded machine movement. Per the SAE J1939-71 standard:

- if the joystick internal diagnostics detect a shaft position measurement error, the joystick output will be set to a value of 1022 counts regardless of shaft position.
- if a specific joystick axis is not available, the basic joystick message for the unavailable axis will indicate an output value of 1023 counts.

Ensure application software recognizes these conditions to avoid the possibility of unintended machine motion.

**Joystick button 1-8 pressed status**

*Joystick button 1-8 pressed status*

Bit status	Remarks
00	Button not pressed
01	Button pressed

*Joystick button 1-8 pressed status (continued)*

Bit status	Remarks
10	Error indicator
11	Not available (no button installed)

## SAE J1939 extended joystick message

The JS1-H joystick uses the SAE J1939 extended joystick message to transfer information about the measured status of up to 3 additional proportional input functions on the joystick grip, and external-to-the-joystick analog inputs. The joystick base X and Y-axis information is available in the basic joystick message.

### Extended joystick message structure

Message number	Priority	Base PGN		PDU format		PDU specific		Source address		Data field
		Dec	hex	Dec	hex	Dec	hex	Dec	hex	
1	3	64983	FDD7	253	FD	215	D7	The source address depends on position specified in master model code.		8 bytes
3	3	64987	FDDB	253	FD	219	DB	The source address depends on position specified in master model code.		8 bytes

Message transmission rate: 20 ms

CAN bus baud rate: 250kbps

The resulting SAE J1939 extended joystick message PGN on the CAN bus is:

0xCFDD7 \*\_\*\_ or 0xCFDDB \*\_\*\_

\* = joystick source address (hex)

## Extended joystick message parameters and data field descriptions

### Extended joystick message parameters and data field locations

Start position (Byte/Bit)	Length (Bits)	Parameter name
0/1	2	Grip X-axis neutral position status
0/3	2	Grip X-axis lever left negative position status
0/5	2	Grip X-axis lever right positive position status
0/7 through 1/1-8	10	Grip X-axis position
2/1	2	Grip Y-axis neutral position status
2/3	2	Grip Y-axis lever back negative position
2/5	2	Grip Y-axis lever forward positive position
2/7 through 3/1-8	10	Grip Y-axis position
6/5	2	Grip Y-axis detent position status-not available
6/7	2	Grip X-axis detent position status-not available

Data field descriptions and output ranges for extended joystick messages are similar to those for base X-axis and Y-axis basic joystick messages.

### Grip proportional input naming convention

Proportional input location	Extended joystick message designation
Horizontal orientation, top	X-axis
Horizontal orientation, bottom	Y-axis
Vertical orientation, left side	X-axis
Vertical orientation, right side	Y-axis

## SAE J1939 error (DM1) messages

SAE J1939 DM1 error messages are supported. Suspect Parameter Number (SPN) and Failure Mode Identifier (FMI) information are in the following tables.

### *Failure: Voltage too high*

Message	Axis	SPN	FMI
EJM1	X	2660	3
EJM1	Y	2661	3
EJM1	Grip X	2662	3
EJM1	Grip Y	2663	3
EJM1	Grip Theta	2664	3

### *Failure: Voltage too low*

Message	Axis	SPN	FMI
EJM1	X	2660	4
EJM1	Y	2661	4
EJM1	Grip X	2662	4
EJM1	Grip Y	2663	4
EJM1	Grip Theta	2664	4

### *Failure: Input not calibrated*

Message	Axis	SPN	FMI
EJM1	X	2660	13
EJM1	Y	2661	13
EJM1	Grip X	2662	13
EJM1	Grip Y	2663	13
EJM1	Grip Theta	2664	13

### *Failure: Redundant input failure*

Message	Axis	SPN	FMI
EJM1	X	2660	14
EJM1	Y	2661	14
EJM1	Grip X	2662	14
EJM1	Grip Y	2663	14
EJM1	Grip Theta	2664	14

SAE J1939 dynamic addressing is not supported, since the joystick source addresses are hard-coded (static). However, there is SAE J1939 address claiming protocol compliance. In the unlikely event another node on the SAE J1939 bus claims an identical source address to the joystick, the joystick may cease communication on the bus, depending on the message priority on the other node.

## Appendix: CAN+ and CANopen protocol

*CANopen Object Dictionary for JS1-H joysticks* on page 84

*Parameter/variable index - JS1-H CAN, JS1-H CANalog* on page 85

*Parameter/variable index - JS1-H CAN+* on page 96

*Error handling* on page 107

## CANopen Object Dictionary for JS1-H joysticks

To access the CANopen Object Dictionary go to <https://www.danfoss.com/en/products/electronic-controls/dps/plus1-joysticks-and-pedals/>, then under Download find CANopen EDS under the JS1-H.

In order to access an Entry within an Object, the Service Data Object (SDO) is used. The Initiate SDO Download/Upload protocol and the Upload SDO Segment protocol (used when data type is VISIBLE\_STRING) are supported. Each Object has an Index and a Name. For each Entry within an Object there is a Sub-Index followed by a Name and a Description (if applicable).

The different Data types of an Entry can be as follows:

- U32 (UNSIGNED32), U16 (UNSIGNED16) or U8 (UNSIGNED8)
- S32 (INTEGER32), S16 (INTEGER16) or S8 (INTEGER8)
- STR (VISIBLE\_STRING)
- NEUTRAL\_STATE (2 bit state value)

The Access of an Entry can be as follows:

- ro (Read Only)
- rw (Read Write)
- wo (Write Only)
- const

The minimum and maximum value of an Entry is also specified where applicable. This does not mean that there is a check within the joystick that the written value is within the value range, for example, the User is responsible to write a value within the value range. It should also be observed that the Default value of an Entry may not be true for all applications. The Unit/Scale gives either the unit of the value and/or the scaling used where applicable.

### ***CANopen Baud Rate and Node ID setting***

Baud rate and Node ID may be set using the Danfoss PLUS+1<sup>®</sup> Service Tool. Additionally, the parameters can be set using the CANopen LSS protocol.

CiA<sup>®</sup> 305: Layer Setting Services (LSS)

LSS distinguishes between an LSS master (typically residing in the host controller) and the LSS slaves. LSS enables the LSS master to modify the LSS slaves' CANopen node-ID and to switch the entire network from one data rate to another. LSS utilizes exactly two CAN frames. The CAN data frame 7E5h carries the command from the LSS master to one or several LSS slaves. The CAN frame 7E4h is used to provide the response(s) to the LSS master. LSS is specified in the document CiA 305.

## Parameter/variable index - JS1-H CAN, JS1-H CANalog

### 40h Device type

Sub-index	Name	Description	Data type	Access	Minimum	Maximum	Default	Unit/Scale
0	NEUTRAL_ST ATE	2-bit Proportional Axis (Neutral State) data type. 0x00 = Neutral 0x01 = Out Of Neutral 0x02 = Error 0x03 = Not Available	U32	ro	-	-	-	-

### 1000h Device type

Sub-index	Name	Description	Data type	Access	Minimum	Maximum	Default	Unit/Scale
0	Device Type	01050191h: Joystick without digital outputs	U32	const	-	-	See description	-

### 1001h Device register

Sub-index	Name	Description	Data type	Access	Minimum	Maximum	Default	Unit/Scale
0	Error Register	Bit 0 (Generic): 1 in case of an unknown error Bit 1 (Current): Always zero Bit 2 (Voltage): 1 in case of a voltage to high or low Bit 3 (Temperature): Always zero Bit 4 (Communication Error): Always zero Bit 5 (Device Profile Specific): Always zero Bit 6 (Reserved): Always zero Bit 7 (Manufacture-Specific): 1 in case of an IIC grip communication error, or a calibration error	U8	ro	-	-	-	-

### 1003h Error log: Code

Sub-index	Name	Description	Data type	Access	Minimum	Maximum	Default	Unit/Scale
0h	Log size	The entry at sub-index 0 contains the number of actual errors that are recorded starting at sub-index 1. Writing a zero to sub-index 0 clears the error log. Writing a value other than zero to sub-index 0 will result in an abort message.	U8	rw	0	24	-	-
1h	Error 1 Code	Every new error is stored at sub-index 1, the older ones move down the list.	U32	ro	0	2 <sup>32</sup> -1	-	-
2h	Error 2 Code		U32	ro	0	2 <sup>32</sup> -1	-	-
3h	Error 3 Code		U32	ro	0	2 <sup>32</sup> -1	-	-
4h	Error 4 Code		U32	ro	0	2 <sup>32</sup> -1	-	-
5h	Error 5 Code		U32	ro	0	2 <sup>32</sup> -1	-	-
6h	Error 6 Code		U32	ro	0	2 <sup>32</sup> -1	-	-
7h	Error 7 Code		U32	ro	0	2 <sup>32</sup> -1	-	-
8h	Error 8 Code		U32	ro	0	2 <sup>32</sup> -1	-	-
9h	Error 9 Code		U32	ro	0	2 <sup>32</sup> -1	-	-

1003h Error log: Code (continued)

Sub-index	Name	Description	Data type	Access	Minimum	Maximum	Default	Unit/Scale
Ah	Error 10 Code		U32	ro	0	2 <sup>32</sup> -1	-	-
Bh	Error 11 Code		U32	ro	0	2 <sup>32</sup> -1	-	-
Ch	Error 12 Code		U32	ro	0	2 <sup>32</sup> -1	-	-
Dh	Error 13 Code		U32	ro	0	2 <sup>32</sup> -1	-	-
Eh	Error 14 Code		U32	ro	0	2 <sup>32</sup> -1	-	-
Fh	Error 15 Code		U32	ro	0	2 <sup>32</sup> -1	-	-
10h	Error 16 Code		U32	ro	0	2 <sup>32</sup> -1	-	-
11h	Error 17 Code		U32	ro	0	2 <sup>32</sup> -1	-	-
12h	Error 18 Code		U32	ro	0	2 <sup>32</sup> -1	-	-
13h	Error 19 Code		U32	ro	0	2 <sup>32</sup> -1	-	-
14h	Error 20 Code		U32	ro	0	2 <sup>32</sup> -1	-	-
15h	Error 21 Code		U32	ro	0	2 <sup>32</sup> -1	-	-
16h	Error 22 Code		U32	ro	0	2 <sup>32</sup> -1	-	-
17h	Error 23 Code		U32	ro	0	2 <sup>32</sup> -1	-	-
18h	Error 24 Code		U32	ro	0	2 <sup>32</sup> -1	-	-

1008h Manufacturer device name

Sub-index	Name	Description	Data type	Access	Minimum	Maximum	Default	Unit/Scale
0	Manufacturer Device Name	JS1-H device family name. Returns "JOYSTICK"	STR	Const	-	-	-	-

1009h Manufacturer hardware version

Sub-index	Name	Description	Data type	Access	Minimum	Maximum	Default	Unit/Scale
0	Manufacturer Hardware Version	Hardware part number. The part number will be different for joystick models.	STR	Const	-	-	-	-

100Ah Manufacturer software version

Sub-index	Name	Description	Data type	Access	Minimum	Maximum	Default	Unit/Scale
0	Manufacturer Software Version	Software part number and version.	STR	Const	-	-	-	-

1014h COB-ID EMCY message

Sub-index	Name	Description	Data type	Access	Minimum	Maximum	Default	Unit/Scale
0	COB-ID EMCY Message	Defines the COB-ID of the EMCY object.	U32	ro	0	2 <sup>32</sup> -1	80h+ Node ID	-

1017h Producer heartbeat time

Sub-index	Name	Description	Data type	Access	Minimum	Maximum	Default	Unit/Scale
0	Producer	Time in milliseconds on how often the Joystick will transmit a heartbeat. A value of 0 will disable the heartbeat. It requires a reboot for the value to take effect after change.	U16	rw	0	2 <sup>32</sup> -1	20	-

1018h Identity object

Sub-index	Name	Description	Data type	Access	Minimum	Maximum	Default	Unit/Scale
0	Number of entries		U8	const	-	-	4	-
1	Vendor Id	Returns the Vendor Id for JS1-H = 19h.	U32	const	-	-	19h	-
2	Product Code		U32	const	-	-	1h	-
3	Revision Number		U32	const	-	-	10001h	-
4	Serial Number	Device serial number.	U32	const	-	-	-	-

1200h Server SDO1 parameters

Sub-index	Name	Description	Data type	Access	Minimum	Maximum	Default	Unit/Scale
0	Number of entries		U8	const	-	-	2	-
1	COB-ID used by SDO 1 rx		U32	ro	0	$2^{32}-1$	600h+ Node Id	-
2	COB-ID used by SDO 1 tx		U32	ro	0	$2^{32}-1$	580h+ Node Id	-

1800h Transmit PDO1 communication parameters

Sub-index	Name	Description	Data type	Access	Minimum	Maximum	Default	Unit/Scale
0	Number of entries		U8	const	-	-	5	-
1	COB-ID used by PDO1 Tx		U32	ro	0	$2^{32}-1$	180h+ Node Id + $2^{30}$	-
2	Transmission Type	FEh: event driven (manufacturer specific)	U8	ro	0	255	FEh	-
3	Inhibit Time	The time is the minimum interval for PDO transmission. The value is defined as multiple of 100 microseconds. The value of 0 shall disable the inhibit time.	U16	rw	0	$2^{16}-1$	0	ms/10
4	Reserved	Not implemented; a read or write access results in an SDO abort with abort code 06090011h.	-	-	-	-	-	-
5	Event Time	The time is the maximum interval for PDO transmission. The value of 0 shall disable the event timer, resulting in the PDO not being transmitted.	U16	rw	0	$2^{16}-1$	20	ms

1801h Transmit PDO2 communication parameters

Sub-index	Name	Description	Data type	Access	Minimum	Maximum	Default	Unit/Scale
0	Number of entries		U8	const	-	-	5	-
1	COB-ID used by PDO2 Tx		U32	ro	0	$2^{32}-1$	280h + Node Id + $2^{30}$	-

1801h Transmit PDO2 communication parameters (continued)

Sub-index	Name	Description	Data type	Access	Minimum	Maximum	Default	Unit/Scale
2	Transmission Type	FEh: event driven (manufacturer specific)	U8	ro	0	255	FEh	-
3	Inhibit Time	The time is the minimum interval for PDO transmission. The value is defined as multiple of 100 microseconds. The value of 0 shall disable the inhibit time.	U16	rw	0	$2^{16}-1$	0	ms/10
4	Reserved	Not implemented; a read or write access results in an SDO abort with abort code 06090011h.	-	-	-	-	-	-
5	Event Timer	The time is the maximum interval for PDO transmission. The value of 0 shall disable the event timer, resulting in the PDO not being transmitted.	U16	rw	0	$2^{16}-1$	20	ms

1802h Transmit PDO3 communication parameters

Sub-index	Name	Description	Data type	Access	Minimum	Maximum	Default	Unit/Scale
0	Number of entries		U8	const	-	-	5	-
1	COB-ID used by PDO3 Tx		U32	ro	0	$2^{32}-1$	380h + Node Id + $2^{30}$	-
2	Transmission Type	FEh: event driven (manufacturer specific)	U8	ro	0	255	FEh	-
3	Inhibit Time	The time is the minimum interval for PDO transmission. The value is defined as multiple of 100 microseconds. The value of 0 shall disable the inhibit time.	U16	rw	0	$2^{16}-1$	0	ms/10
4	Reserved	Not implemented; a read or write access results in an SDO abort with abort code 06090011h.	-	-	-	-	-	-
5	Event Timer	The time is the maximum interval for PDO transmission. The value of 0 shall disable the event timer, resulting in the PDO not being transmitted.	U16	rw	0	$2^{16}-1$	20	ms

1A00h Transmit PDO1 map parameters

Sub-index	Name	Description	Data type	Access	Minimum	Maximum	Default	Unit/Scale
0	Number of Mapped Applications Objects in PDO1Tx		U8	ro	0	49	49	-
1	Mapping for Proportional Memory Freeze Status	Example: 6000h:1 gives value=60000108h where index=6000h sub-index=01h data type=08h (8bits)	U32	ro	0	2 <sup>32</sup> -1	60000108h	-
2	Mapping for Button 1	Button status	U32	ro	0	2 <sup>32</sup> -1	60200101h	-
3	Mapping for Button 2	Button status	U32	ro	0	2 <sup>32</sup> -1	60200201h	-
4	Mapping for Button 3	Button status	U32	ro	0	2 <sup>32</sup> -1	60200301h	-
5	Mapping for Button 4	Button status	U32	ro	0	2 <sup>32</sup> -1	60200401h	-
6	Mapping for Button 5	Button status	U32	ro	0	2 <sup>32</sup> -1	60200401h	-
7	Mapping for Button 6	Button status	U32	ro	0	2 <sup>32</sup> -1	60200601h	-
8	Mapping for Button 7	Button status	U32	ro	0	2 <sup>32</sup> -1	60200701h	-
9	Mapping for Button 8	Button status	U32	ro	0	2 <sup>32</sup> -1	60200801h	-
10	Mapping for Button 9	Button status	U32	ro	0	2 <sup>32</sup> -1	60200901h	-
11	Mapping for Button 10	Button status	U32	ro	0	2 <sup>32</sup> -1	60200A01h	-
12	Mapping for Button 11	Button status	U32	ro	0	2 <sup>32</sup> -1	60200B01h	-
13	Mapping for Button 12	Button status	U32	ro	0	2 <sup>32</sup> -1	60200C01h	-
14	Mapping for Button 13	Button status	U32	ro	0	2 <sup>32</sup> -1	60200D01h	-
15	Mapping for Button 14	Button status	U32	ro	0	2 <sup>32</sup> -1	60200E01h	-
16	Mapping for Button 15	Button status	U32	ro	0	2 <sup>32</sup> -1	60200F01h	-
17	Mapping for Button 16	Button status	U32	ro	0	2 <sup>32</sup> -1	60201001h	-
18	Mapping for Button 17	Button status	U32	ro	0	2 <sup>32</sup> -1	60201101h	-
19	Mapping for Button 18	Button status	U32	ro	0	2 <sup>32</sup> -1	60201201h	-
20	Mapping for Button 19	Button status	U32	ro	0	2 <sup>32</sup> -1	60201301h	-
21	Mapping for Button 20	Button status	U32	ro	0	2 <sup>32</sup> -1	60201401h	-
22	Mapping for Button 21	Button status	U32	ro	0	2 <sup>32</sup> -1	60201501h	-
23	Mapping for Button 22	Button status	U32	ro	0	2 <sup>32</sup> -1	60201601h	-
24	Mapping for Button 23	Button status	U32	ro	0	2 <sup>32</sup> -1	60201701h	-
25	Mapping for Button 24	Button status	U32	ro	0	2 <sup>32</sup> -1	60201801h	-

## 1A00h Transmit PD01 map parameters (continued)

Sub-index	Name	Description	Data type	Access	Minimum	Maximum	Default	Unit/Scale
26	Reserved	Example: 6000h:2 gives value=6000208h where index=6000h sub-index=02h data type=08h (8 bits)	U32	ro	0	2 <sup>32</sup> -1	6000208h	-
27	Mapping for Button 1	Button enabled	U32	ro	0	2 <sup>32</sup> -1	60201901h	-
28	Mapping for Button 2	Button enabled	U32	ro	0	2 <sup>32</sup> -1	60201A01h	-
29	Mapping for Button 3	Button enabled	U32	ro	0	2 <sup>32</sup> -1	60201B01h	-
30	Mapping for Button 4	Button enabled	U32	ro	0	2 <sup>32</sup> -1	60201C01h	-
31	Mapping for Button 5	Button enabled	U32	ro	0	2 <sup>32</sup> -1	60201D01h	-
32	Mapping for Button 6	Button enabled	U32	ro	0	2 <sup>32</sup> -1	60201E01h	-
33	Mapping for Button 7	Button enabled	U32	ro	0	2 <sup>32</sup> -1	60201F01h	-
34	Mapping for Button 8	Button enabled	U32	ro	0	2 <sup>32</sup> -1	60202001h	-
35	Mapping for Button 9	Button enabled	U32	ro	0	2 <sup>32</sup> -1	60202101h	-
36	Mapping for Button 10	Button enabled	U32	ro	0	2 <sup>32</sup> -1	60202201h	-
37	Mapping for Button 11	Button enabled	U32	ro	0	2 <sup>32</sup> -1	60202301h	-
38	Mapping for Button 12	Button enabled	U32	ro	0	2 <sup>32</sup> -1	60202401h	-
39	Mapping for Button 13	Button enabled	U32	ro	0	2 <sup>32</sup> -1	60202501h	-
40	Mapping for Button 14	Button enabled	U32	ro	0	2 <sup>32</sup> -1	60202601h	-
41	Mapping for Button 15	Button enabled	U32	ro	0	2 <sup>32</sup> -1	60202701h	-
42	Mapping for Button 16	Button enabled	U32	ro	0	2 <sup>32</sup> -1	60202801h	-
43	Mapping for Button 17	Button enabled	U32	ro	0	2 <sup>32</sup> -1	60202901h	-
44	Mapping for Button 18	Button enabled	U32	ro	0	2 <sup>32</sup> -1	60202A01h	-
45	Mapping for Button 19	Button enabled	U32	ro	0	2 <sup>32</sup> -1	60202B01h	-
46	Mapping for Button 20	Button enabled	U32	ro	0	2 <sup>32</sup> -1	60202C01h	-
47	Mapping for Button 21	Button enabled	U32	ro	0	2 <sup>32</sup> -1	60202D01h	-
48	Mapping for Button 22	Button enabled	U32	ro	0	2 <sup>32</sup> -1	60202E01h	-
49	Mapping for Button 23	Button enabled	U32	ro	0	2 <sup>32</sup> -1	60202F01h	-
50	Mapping for Button 24	Button enabled	U32	ro	0	2 <sup>32</sup> -1	60203001h	-

1A01h Transmit PDO2 map parameters

Sub-index	Name	Description	Data type	Access	Minimum	Maximum	Default	Unit/Scale
0	Number of Mapped Applications Objects in PDO2Tx		U8	ro	0	6	6	-
1	Mapping for X-Axis Proportional	Example: 6401h:1 gives value=64010110h where index=6401h sub-index=01h data type=10h (16 bits)	U32	ro	0	2 <sup>32</sup> -1	64010110h	-
2	Mapping for Y-Axis Proportional		U32	ro	0	2 <sup>32</sup> -1	64010210h	-
3	Reserved	Example: 6405h:1 gives value=64050110h where index=6405h sub-index=01h data type=10h (16 bits)	U32	ro	0	2 <sup>32</sup> -1	64050110h	-
4	Mapping for X-Axis Neutral State	Example: 6404h:1 gives value=64040102h where index=6404h sub-index=01h data type=02h (2 bits)	U32	ro	0	2 <sup>32</sup> -1	64040102h	-
5	Mapping for Y-Axis Neutral State		U32	ro	0	2 <sup>32</sup> -1	64040202h	-
6	Reserved	Example: 6406h:1 gives value=64060102h where index=6406h sub-index=01h data type=02h (2 bits)	U32	ro	0	2 <sup>32</sup> -1	64060102h	-

1A02h Transmit PDO3 map parameters

Sub-index	Name	Description	Data type	Access	Minimum	Maximum	Default	Unit/Scale
0	Number of Mapped Applications Objects in PDO3Tx		U8	ro	0	6	6	-
1	Mapping for Grip 1 Proportional	Example: 6401h:1 gives value=64010310h where index=6401h sub-index=03h data type=10h (16 bits)	U32	ro	0	2 <sup>32</sup> -1	64010310h	-
2	Mapping for Grip 2 Proportional		U32	ro	0	2 <sup>32</sup> -1	64010410h	-
3	Mapping for Grip 3 Proportional		U32	ro	0	2 <sup>32</sup> -1	64010510h	-
4	Mapping for Grip 1 Axis Neutral State	Example: 6404h:3 gives value=64040302h where index=6404h sub-index=03h data type=02h (2 bits)	U32	ro	0	2 <sup>32</sup> -1	64040302h	-

1A02h Transmit PD03 map parameters (continued)

Sub-index	Name	Description	Data type	Access	Minimum	Maximum	Default	Unit/Scale
5	Mapping for Grip 2 Axis Neutral State		U32	ro	0	2 <sup>32</sup> -1	64040402h	-
6	Mapping for Grip 3 Axis Neutral State		U32	ro	0	2 <sup>32</sup> -1	64040502h	-

6000h Read input 8-bit

Sub-index	Name	Description	Data type	Access	Minimum	Maximum	Default	Unit/Scale
0	Number of Inputs 8-Bit		U8	ro	0	1	-	-
1	Proportional Memory Freeze	*Not supported Memory status for the proportional outputs. 0: memory function off (release proportional values) 1: memory functions on (freeze proportional values)	U8	ro	0	0	0	-
2	Proportional Memory Freeze	*Not supported Memory status for the proportional outputs. 0: memory function off (release proportional values) 1: memory functions on (freeze proportional values)	U8	ro	0	0	0	-

6020h Read input bit (buttons)

Sub-index	Name	Description	Data type	Access	Minimum	Maximum	Default	Unit/Scale
0	Number of Inputs Bits		U8	ro	0	32	32	-
1	Freeze Bit 1	*Not supported Memory status for the proportional outputs. 0: memory function off (release proportional values) 1: memory functions on (freeze proportional values)	U8	ro	0	0	0	-
2	Freeze Bit 2	*Not supported	U8	ro	0	0	0	-
3	Freeze Bit 3	*Not supported	U8	ro	0	0	0	-
4	Freeze Bit 4	*Not supported	U8	ro	0	0	0	-
5	Freeze Bit 5	*Not supported	U8	ro	0	0	0	-
6	Freeze Bit 6	*Not supported	U8	ro	0	0	0	-
7	Freeze Bit 7	*Not supported	U8	ro	0	0	0	-
8	Freeze Bit 8	*Not supported	U8	ro	0	0	0	-
9	Button 1	0: Not Pressed 1: Pressed	U8	ro	0	1	0	-
10	Button 2	See Button 1 (Sub Index 9)	U8	ro	0	1	0	-
11	Button 3	See Button 1 (Sub Index 9)	U8	ro	0	1	0	-
12	Button 4	See Button 1 (Sub Index 9)	U8	ro	0	1	0	-
13	Button 5	See Button 1 (Sub Index 9)	U8	ro	0	1	0	-
14	Button 6	See Button 1 (Sub Index 9)	U8	ro	0	1	0	-
15	Button 7	See Button 1 (Sub Index 9)	U8	ro	0	1	0	-
16	Button 8	See Button 1 (Sub Index 9)	U8	ro	0	1	0	-
17	Button 9	See Button 1 (Sub Index 9)	U8	ro	0	1	0	-

6020h Read input bit (buttons) (continued)

Sub-index	Name	Description	Data type	Access	Minimum	Maximum	Default	Unit/Scale
18	Button 10	See Button 1 (Sub Index 9)	U8	ro	0	1	0	-
19	Button 11	See Button 1 (Sub Index 9)	U8	ro	0	1	0	-
20	Button 12	See Button 1 (Sub Index 9)	U8	ro	0	1	0	-
21	Button 13	See Button 1 (Sub Index 9)	U8	ro	0	1	0	-
22	Button 14	See Button 1 (Sub Index 9)	U8	ro	0	1	0	-
23	Button 15	See Button 1 (Sub Index 9)	U8	ro	0	1	0	-
24	Button 16	See Button 1 (Sub Index 9)	U8	ro	0	1	0	-
25	Button 17	See Button 1 (Sub Index 9)	U8	ro	0	1	0	-
26	Button 18	See Button 1 (Sub Index 9)	U8	ro	0	1	0	-
27	Button 19	See Button 1 (Sub Index 9)	U8	ro	0	1	0	-
28	Button 20	See Button 1 (Sub Index 9)	U8	ro	0	1	0	-
29	Button 21	See Button 1 (Sub Index 9)	U8	ro	0	1	0	-
30	Button 22	See Button 1 (Sub Index 9)	U8	ro	0	1	0	-
31	Button 23	See Button 1 (Sub Index 9)	U8	ro	0	1	0	-
32	Button 24	See Button 1 (Sub Index 9)	U8	ro	0	1	0	-
33	Button 1	0: Not Enabled 1: Enabled	U8	ro	0	1	0	-
34	Button 2	See Button 1 (Sub Index 33)	U8	ro	0	1	0	-
35	Button 3	See Button 1 (Sub Index 33)	U8	ro	0	1	0	-
36	Button 4	See Button 1 (Sub Index 33)	U8	ro	0	1	0	-
37	Button 5	See Button 1 (Sub Index 33)	U8	ro	0	1	0	-
38	Button 6	See Button 1 (Sub Index 33)	U8	ro	0	1	0	-
39	Button 7	See Button 1 (Sub Index 33)	U8	ro	0	1	0	-
40	Button 8	See Button 1 (Sub Index 33)	U8	ro	0	1	0	-
41	Button 9	See Button 1 (Sub Index 33)	U8	ro	0	1	0	-
42	Button 10	See Button 1 (Sub Index 33)	U8	ro	0	1	0	-
43	Button 11	See Button 1 (Sub Index 33)	U8	ro	0	1	0	-
44	Button 12	See Button 1 (Sub Index 33)	U8	ro	0	1	0	-
45	Button 13	See Button 1 (Sub Index 33)	U8	ro	0	1	0	-
46	Button 14	See Button 1 (Sub Index 33)	U8	ro	0	1	0	-
47	Button 15	See Button 1 (Sub Index 33)	U8	ro	0	1	0	-
48	Button 16	See Button 1 (Sub Index 33)	U8	ro	0	1	0	-
49	Button 17	See Button 1 (Sub Index 33)	U8	ro	0	1	0	-
50	Button 18	See Button 1 (Sub Index 33)	U8	ro	0	1	0	-
51	Button 19	See Button 1 (Sub Index 33)	U8	ro	0	1	0	-
52	Button 20	See Button 1 (Sub Index 33)	U8	ro	0	1	0	-
53	Button 21	See Button 1 (Sub Index 33)	U8	ro	0	1	0	-
54	Button 22	See Button 1 (Sub Index 33)	U8	ro	0	1	0	-
55	Button 23	See Button 1 (Sub Index 33)	U8	ro	0	1	0	-
56	Button 24	See Button 1 (Sub Index 33)	U8	ro	0	1	0	-

6401h Read analog inputs 16-Bit

Sub-index	Name	Description	Data type	Access	Minimum	Maximum	Default	Unit/Scale
0	Number of Analog Inputs 16-Bit		U8	ro	0	10	-	-
1	X-Axis Proportional		S16	ro	-1000	1000	0	%*10

6401h Read analog inputs 16-Bit (continued)

Sub-index	Name	Description	Data type	Access	Minimum	Maximum	Default	Unit/Scale
2	Y-Axis Proportional		S16	ro	-1000	1000	0	%*10
3	Grip 1 Proportional		S16	ro	-1000	1000	0	%*10
4	Grip 2 Proportional		S16	ro	-1000	1000	0	%*10
5	Grip 3 Proportional		S16	ro	-1000	1000	0	%*10
6	Axis 5		S16	ro	-1000	1000	0	%*10
7	Axis 6		S16	ro	-1000	1000	0	%*10
8	Axis 7		S16	ro	-1000	1000	0	%*10
9	Axis 8		S16	ro	-1000	1000	0	%*10
10	Axis 9		S16	ro	-1000	1000	0	%*10

6404h Manufacturer specific input 2-Bit

Sub-index	Name	Description	Data type	Access	Minimum	Maximum	Default	Unit/Scale
0	Number of Mfg Specific Inputs 2-Bit		U8	ro	0	10	-	-
1	X-Axis Proportional Neutral State		U8	ro	0	3	0	00 – Neutral 01 – Out of Neutral 10 – Error 11 – Not Available
2	Y-Axis Proportional Neutral State		U8	ro	0	3	0	See Sub Index 1
3	Grip 1 Proportional Neutral State		U8	ro	0	3	0	See Sub Index 1
4	Grip 2 Proportional Neutral State		U8	ro	0	3	0	See Sub Index 1
5	Grip 3 Proportional Neutral State		U8	ro	0	3	0	See Sub Index 1
6	Axis 5 Neutral State		U8	ro	0	3	0	See Sub Index 1
7	Axis 6 Neutral State		U8	ro	0	3	0	See Sub Index 1
8	Axis 7 Neutral State		U8	ro	0	3	0	See Sub Index 1
9	Axis 8 Neutral State		U8	ro	0	3	0	See Sub Index 1
10	Axis 9 Neutral State		U8	ro	0	3	0	See Sub Index 1

6405h Manufacturer specific reserved 16-Bit

Sub-index	Name	Description	Data type	Access	Minimum	Maximum	Default	Unit/Scale
0	Number of Mfg Specific Reserved 16-Bit		U16	ro	0	1	-	-
1	Reserved 1		U16	ro	0	2 <sup>16</sup> -1	0	

*6406h Manufacturer specific reserved 2-Bit*

Sub-index	Name	Description	Data type	Access	Minimum	Maximum	Default	Unit/Scale
0	Number of Mfg Specific Reserved 2-Bit		U8	ro	0	1	-	-
1	Reserved 1		U8	ro	0	3	0	

## Parameter/variable index - JS1-H CAN+

### 40h Device type

Sub-index	Name	Description	Data type	Access	Minimum	Maximum	Default	Unit/Scale
0	NEUTRAL_ST ATE	2-bit Proportional Axis (Neutral State) data type. 0x00 = Neutral 0x01 = Out Of Neutral 0x02 = Error 0x03 = Not Available	U32	ro	=	=	=	=

### 1000h Device type

Sub-index	Name	Description	Data type	Access	Minimum	Maximum	Default	Unit/Scale
0	Device Type	01050191h: Joystick without digital outputs	U32	const	=	=	See description	=

### 1001h Device register

Sub-index	Name	Description	Data type	Access	Minimum	Maximum	Default	Unit/Scale
0	Error Register	Bit 0 (Generic): 1 in case of an unknown error Bit 1 (Current): Always zero Bit 2 (Voltage): 1 in case of a voltage to high or low Bit 3 (Temperature): Always zero Bit 4 (Communication Error): Always zero Bit 5 (Device Profile Specific): Always zero Bit 6 (Reserved): Always zero Bit 7 (Manufacture-Specific): 1 in case of an IIC grip communication error, or a calibration error	U8	ro	=	=	=	=

### 1003h Error log: Code

Sub-index	Name	Description	Data type	Access	Minimum	Maximum	Default	Unit/Scale
0h	Log size	The entry at sub-index 0 contains the number of actual errors that are recorded starting at sub-index 1. Writing a zero to sub-index 0 clears the error log. Writing a value other than zero to sub-index 0 will result in an abort message.	U8	rw	0	24	=	=
1h	Error 1 Code	Every new error is stored at sub-index 1, the older ones move down the list.	U32	ro	0	2 <sup>32</sup> -1	=	=
2h	Error 1 Code		U32	ro	0	2 <sup>32</sup> -1	=	=
3h	Error 1 Code		U32	ro	0	2 <sup>32</sup> -1	=	=
4h	Error 1 Code		U32	ro	0	2 <sup>32</sup> -1	=	=
5h	Error 1 Code		U32	ro	0	2 <sup>32</sup> -1	=	=
6h	Error 1 Code		U32	ro	0	2 <sup>32</sup> -1	=	=
7h	Error 1 Code		U32	ro	0	2 <sup>32</sup> -1	=	=
8h	Error 1 Code		U32	ro	0	2 <sup>32</sup> -1	=	=
9h	Error 1 Code		U32	ro	0	2 <sup>32</sup> -1	=	=
Bh	Error 1 Code		U32	ro	0	2 <sup>32</sup> -1	=	=
Ch	Error 1 Code		U32	ro	0	2 <sup>32</sup> -1	=	=

1003h Error log: Code (continued)

Sub-index	Name	Description	Data type	Access	Minimum	Maximum	Default	Unit/Scale
Dh	Error 1 Code		U32	ro	0	2 <sub>32</sub> -1	=	=
Eh	Error 1 Code		U32	ro	0	2 <sub>32</sub> -1	=	=
Fh	Error 1 Code		U32	ro	0	2 <sub>32</sub> -1	=	=
10h	Error 1 Code		U32	ro	0	2 <sub>32</sub> -1	=	=
11h	Error 1 Code		U32	ro	0	2 <sub>32</sub> -1	=	=
12h	Error 1 Code		U32	ro	0	2 <sub>32</sub> -1	=	=
13h	Error 1 Code		U32	ro	0	2 <sub>32</sub> -1	=	=
14h	Error 1 Code		U32	ro	0	2 <sub>32</sub> -1	=	=
15h	Error 1 Code		U32	ro	0	2 <sub>32</sub> -1	=	=
16h	Error 1 Code		U32	ro	0	2 <sub>32</sub> -1	=	=
17h	Error 1 Code		U32	ro	0	2 <sub>32</sub> -1	=	=
18h	Error 1 Code		U32	ro	0	2 <sub>32</sub> -1	=	=

1008h Manufacturer device name

Sub-index	Name	Description	Data type	Access	Minimum	Maximum	Default	Unit/Scale
0	Manufacturer Device Name	JS1-H device family name. Returns "JOYSTICK"	STR	Const	=	=	=	=

1009h Manufacturer hardware version

Sub-index	Name	Description	Data type	Access	Minimum	Maximum	Default	Unit/Scale
0	Manufacturer Hardware Version	Hardware part number. The part number will be different for joystick models.	STR	Const	=	=	=	=

100Ah Manufacturer software version

Sub-index	Name	Description	Data type	Access	Minimum	Maximum	Default	Unit/Scale
0	Manufacturer Software Version	Software part number and version.	STR	Const	=	=	=	=

1014h COB-ID EMCY message

Sub-index	Name	Description	Data type	Access	Minimum	Maximum	Default	Unit/Scale
0	COB-ID EMCY Message	Defines the COB-ID of the EMCY object.	U32	ro	0	2 <sub>32</sub> -1	80h+ Node ID	=

1017h Producer heartbeat time

Sub-index	Name	Description	Data type	Access	Minimum	Maximum	Default	Unit/Scale
0	Producer	Time in milliseconds on how often the Joystick will transmit a heartbeat. A value of 0 will disable the heartbeat. It requires a reboot for the value to take effect after change.	U16	rw	0	2 <sub>32</sub> -1	20	=

1018h Identity object

Sub-index	Name	Description	Data type	Access	Minimum	Maximum	Default	Unit/Scale
0	Number of entries		U8	Const	=	=	4	=
1	Vendor Id	Returns the Vendor Id for JS1-H = 19h.	U32	Const	=	=	19h	=

1018h Identity object (continued)

Sub-index	Name	Description	Data type	Access	Minimum	Maximum	Default	Unit/Scale
2	Product Code		U32	Const	=	=	1h	=
3	Revision Number		U32	Const	=	=	10001h	=
4	Serial Number	Device serial number.	U32	Const	=	=	=	=

1200h Server SDO1 parameters

Sub-index	Name	Description	Data type	Access	Minimum	Maximum	Default	Unit/Scale
0	Number of entries		U8	Const	=	=	2	=
1	COB-ID used by SDO 1 rx		U32	ro	0	$2_{32}-1$	600h+ Node Id	=
2	COB-ID used by SDO 1 tx		U32	ro	0	$2_{32}-1$	580h+ Node Id	=

1800h Transmit PDO1 communication parameters

Sub-index	Name	Description	Data type	Access	Minimum	Maximum	Default	Unit/Scale
0	Number of entries		U8	Const	=	=	5	=
1	COB-ID used by PDO1 Tx		U32	ro	0	$2_{32}-1$	180h+ Node Id + $2_{30}$	=
2	Transmission Type	FEh: event driven (manufacturer specific)	U8	ro	0	255	FEh	=
3	Inhibit Time	The time is the minimum interval for PDO transmission. The value is defined as multiple of 100 microseconds. The value of 0 shall disable the inhibit time.	U16	rw	0	$2_{16}-1$	0	ms/10
4	Reserved	Not implemented; a read or write access results in an SDO abort with abort code 06090011h.	=	=	=	=	=	=
5	Event Time	The time is the maximum interval for PDO transmission. The value of 0 shall disable the event timer, resulting in the PDO not being transmitted.	U16	rw	0	$2_{16}-1$	20	ms

1801h Transmit PDO2 communication parameters

Sub-index	Name	Description	Data type	Access	Minimum	Maximum	Default	Unit/Scale
0	Number of entries		U8	Const	=	=	5	=
1	COB-ID used by PDO2 Tx		U32	ro	0	$2_{32}-1$	280h+ Node Id + $2_{30}$	=
2	Transmission Type	FEh: event driven (manufacturer specific)	U8	ro	0	255	FEh	=
3	Inhibit Time	The time is the minimum interval for PDO transmission. The value is defined as multiple of 100 microseconds. The value of 0 shall disable the inhibit time.	U16	rw	0	$2_{16}-1$	0	ms/10

1801h Transmit PDO2 communication parameters (continued)

Sub-index	Name	Description	Data type	Access	Minimum	Maximum	Default	Unit/Scale
4	Reserved	Not implemented; a read or write access results in an SDO abort with abort code 06090011h.	=	=	0	=	=	=
5	Event Time	The time is the maximum interval for PDO transmission. The value of 0 shall disable the event timer, resulting in the PDO not being transmitted.	U16	rw	0	$2_{16}^{-1}$	20	ms

1802h Transmit PDO3 communication parameters

Sub-index	Name	Description	Data type	Access	Minimum	Maximum	Default	Unit/Scale
0	Number of entries		U8	Const	=	=	5	=
1	COB-ID used by PDO3 Tx		U32	ro	0	$2_{32}^{-1}$	380h+ Node Id + $2_{30}$	=
2	Transmission Type	FEh: event driven (manufacturer specific)	U8	ro	0	255	FEh	=
3	Inhibit Time	The time is the minimum interval for PDO transmission. The value is defined as multiple of 100 microseconds. The value of 0 shall disable the inhibit time.	U16	rw	0	$2_{16}^{-1}$	0	ms/10
4	Reserved	Not implemented; a read or write access results in an SDO abort with abort code 06090011h.	=	=	=	=	=	=
5	Event Time	The time is the maximum interval for PDO transmission. The value of 0 shall disable the event timer, resulting in the PDO not being transmitted.	U16	rw	0	$2_{16}^{-1}$	20	ms

1803h Transmit PDO4 communication parameters

Sub-index	Name	Description	Data type	Access	Minimum	Maximum	Default	Unit/Scale
0	Number of entries		U8	Const	=	=	5	=
1	COB-ID used by PDO3 Tx		U32	ro	0	$2_{32}^{-1}$	380h+ Node Id + $2_{30}$	=
2	Transmission Type	FEh: event driven (manufacturer specific)	U8	ro	0	255	FEh	=
3	Inhibit Time	The time is the minimum interval for PDO transmission. The value is defined as multiple of 100 microseconds. The value of 0 shall disable the inhibit time.	U16	rw	0	$2_{16}^{-1}$	0	ms/10
4	Reserved	Not implemented; a read or write access results in an SDO abort with abort code 06090011h.	=	=	=	=	=	=
5	Event Time	The time is the maximum interval for PDO transmission. The value of 0 shall disable the event timer, resulting in the PDO not being transmitted.	U16	rw	0	$2_{16}^{-1}$	20	ms

1A00h Transmit PDO1 map parameters

Sub-index	Name	Description	Data type	Access	Minimum	Maximum	Default	Unit/Scale
0	Number of Mapped Applications Objects in PDO1Tx		U8	ro	0	39	39	=
1	Mapping for Proportional Memory Freeze Status	Example: 6000h:1 gives value=60000108h where index=6000h sub-index=01h data type=08h (8bits)	U32	ro	0	0	60000108h	=
2	Mapping for Button 1	Button status	U32	ro	0	1	60200101h	=
3	Mapping for Button 2	Button status	U32	ro	0	1	60200201h	=
4	Mapping for Button 3	Button status	U32	ro	0	1	60200301h	=
5	Mapping for Button 4	Button status	U32	ro	0	1	60200401h	=
6	Mapping for Button 5	Button status	U32	ro	0	1	60200401h	=
7	Mapping for Button 6	Button status	U32	ro	0	1	60200401h	=
8	Mapping for Button 7	Button status	U32	ro	0	1	60200701h	=
9	Mapping for Button 8	Button status	U32	ro	0	1	60200801h	=
10	Mapping for Button 9	Button status	U32	ro	0	1	60200901h	=
11	Mapping for Button 10	Button status	U32	ro	0	1	60200A01h	=
12	Mapping for Button 11	Button status	U32	ro	0	1	60200B01h	=
13	Mapping for Button 12	Button status	U32	ro	0	1	60200C01h	=
14	Reserved	Example: 6000h:2 gives value=60000204h where index=6000h sub-index=02h data type=04h (4 bits)	U32	ro	0	0	60000204h	=
15	Mapping for Button 13	Button status	U32	ro	0	1	60200D01h	=
16	Mapping for Button 14	Button status	U32	ro	0	1	60200E01h	=
17	Mapping for Button 15	Button status	U32	ro	0	1	60200F01h	=
18	Mapping for Button 16	Button status	U32	ro	0	1	60201001h	=
19	Mapping for Button 17	Button status	U32	ro	0	1	60201101h	=
20	Mapping for Button 18	Button status	U32	ro	0	1	60201201h	=
21	Mapping for Button 19	Button status	U32	ro	0	1	60201301h	=
22	Mapping for Button 20	Button status	U32	ro	0	1	60201401h	=
23	Mapping for Button 21	Button status	U32	ro	0	1	60201501h	=
24	Mapping for Button 22	Button status	U32	ro	0	1	60201601h	=
25	Mapping for Button 23	Button status	U32	ro	0	1	60201701h	=

1A00h Transmit PDO1 map parameters (continued)

Sub-index	Name	Description	Data type	Access	Minimum	Maximum	Default	Unit/Scale
26	Mapping for Button	Button status	U32	ro	0	1	60201801h	=
27	Reserved	Example: 6000h:2 gives value=60000204h where index=6000h sub-index=02h data type=04h (4 bits)	U32	ro	0	1	60000204h	=
28	Mapping for Button 1	Button enabled	U32	ro	0	1	60201901h	=
29	Mapping for Button 2	Button enabled	U32	ro	0	1	60201A01h	=
30	Mapping for Button 3	Button enabled	U32	ro	0	1	60201B01h	=
31	Mapping for Button 4	Button enabled	U32	ro	0	1	60201C01h	=
32	Mapping for Button 5	Button enabled	U32	ro	0	1	60201D01h	=
33	Mapping for Button 6	Button enabled	U32	ro	0	1	60201E01h	=
34	Mapping for Button 7	Button enabled	U32	ro	0	1	60201F01h	=
35	Mapping for Button 8	Button enabled	U32	ro	0	1	60202001h	=
36	Mapping for Button 9	Button enabled	U32	ro	0	1	60202101h	=
37	Mapping for Button 10	Button enabled	U32	ro	0	1	60202201h	=
38	Mapping for Button 11	Button enabled	U32	ro	0	1	60202301h	=
39	Mapping for Button 12	Button enabled	U32	ro	0	1	60202401h	=

1A01h Transmit PDO2 map parameters

Sub-index	Name	Description	Data type	Access	Minimum	Maximum	Default	Unit/Scale
0	Number of Mapped Applications Objects in PDO2Tx		U8	ro	0	6	6	=
1	Mapping for X-Axis Proportional	Example: 6401h:1 gives value=64010110h where index=6401h sub-index=01h data type=10h (16 bits)	U32	ro	0	2 <sup>32</sup> -1	64010110h	=
2	Mapping for Y-Axis Proportional		U32	ro	0	2 <sup>32</sup> -1	64010210h	=
3	Reserved	Example: 6405h:1 gives value=64050110h where index=6405h sub-index=01h data type=10h (16 bits)	U32	ro	0	2 <sup>32</sup> -1	64050110h	=
4	Mapping for X-Axis Neutral State	Example: 6404h:1 gives value=64040102h where index=6404h sub-index=01h data type=02h (2 bits)	U32	ro	0	2 <sup>32</sup> -1	64040102h	=

1A01h Transmit PDO2 map parameters (continued)

Sub-index	Name	Description	Data type	Access	Minimum	Maximum	Default	Unit/Scale
5	Mapping for Y-Axis Neutral State		U32	ro	0	2 <sup>32</sup> -1	64040202h	=
6	Reserved	Example: 6406h:1 gives value=64060102h where index=6406h sub-index=01h data type=02h (2 bits)	U32	ro	0	2 <sup>32</sup> -1	64060102h	=

1A02h Transmit PDO3 map parameters

Sub-index	Name	Description	Data type	Access	Minimum	Maximum	Default	Unit/Scale
0	Number of Mapped Applications Objects in PDO3Tx		U8	ro	0	6	6	=
1	Mapping for Grip 1 Proportional	Example: 6401h:1 gives value=64010310h where index=6401h sub-index=03h data type=10h (16 bits)	U32	ro	0	2 <sup>32</sup> -1	64010310h	=
2	Mapping for Grip 2 Proportional		U32	ro	0	2 <sup>32</sup> -1	64010410h	=
3	Mapping for Grip 3 Proportional		U32	ro	0	2 <sup>32</sup> -1	64010510h	=
4	Mapping for Grip 1 Axis Neutral State	Example: 6404h:3 gives value=64040302h where index=6404h sub-index=03h data type=02h (2 bits)	U32	ro	0	2 <sup>32</sup> -1	64040302h	=
5	Mapping for Grip 2 Axis Neutral State		U32	ro	0	2 <sup>32</sup> -1	64040402h	=
6	Mapping for Grip 3 Axis Neutral State		U32	ro	0	2 <sup>32</sup> -1	64040502h	=

1A03h Transmit PDO4 map parameters

Sub-index	Name	Description	Data type	Access	Minimum	Maximum	Default	Unit/Scale
0	Number of Mapped Applications Objects in PDO4Tx		U8	ro	0	4	4	=
1	Mapping for X100p11	Example: 6401h:1 gives value=64010610h where index=6401h sub-index=06h data type=10h (16 bits)	U32	ro	0	2 <sup>32</sup> -1	64010610h	=
2	Mapping for X100p12		U32	ro	0	2 <sup>32</sup> -1	64010710h	=
3	Mapping for X100p30		U32	ro	0	2 <sup>32</sup> -1	64010810h	=
4	Mapping for X100p15		U32	ro	0	2 <sup>32</sup> -1	64010910h	=

6000h Read input 8-bit

Sub-index	Name	Description	Data type	Access	Minimum	Maximum	Default	Unit/Scale
0	Number of Inputs 8-Bit		U8	ro	0	1	=	=
1	Proportional Memory Freeze	Not supported Memory status for the proportional outputs. 0: memory function off (release proportional values) 1: memory functions on (freeze proportional values)	U8	ro	0	0	0	=
2	Proportional Memory Freeze	Not supported Memory status for the proportional outputs. 0: memory function off (release proportional values) 1: memory functions on (freeze proportional values)	U8	ro	0	0	0	=

6020h Read input bit (buttons)

Sub-index	Name	Description	Data type	Access	Minimum	Maximum	Default	Unit/Scale
0	Number of Inputs Bits		U8	ro	0	32	32	=
1	Freeze Bit 1	Not supported Memory status for the proportional outputs. 0: memory function off (release proportional values) 1: memory functions on (freeze proportional values)	U8	ro	0	0	0	=
2	Freeze Bit 2	Not supported Memory status for the proportional outputs. 0: memory function off (release proportional values) 1: memory functions on (freeze proportional values)	U8	ro	0	0	0	=
3	Freeze Bit 3	Not supported Memory status for the proportional outputs. 0: memory function off (release proportional values) 1: memory functions on (freeze proportional values)	U8	ro	0	0	0	=
4	Freeze Bit 4	Not supported Memory status for the proportional outputs. 0: memory function off (release proportional values) 1: memory functions on (freeze proportional values)	U8	ro	0	0	0	=
5	Freeze Bit 5	Not supported Memory status for the proportional outputs. 0: memory function off (release proportional values) 1: memory functions on (freeze proportional values)	U8	ro	0	0	0	=

6020h Read input bit (buttons) (continued)

Sub-index	Name	Description	Data type	Access	Minimum	Maximum	Default	Unit/Scale
6	Freeze Bit 6	Not supported Memory status for the proportional outputs. 0: memory function off (release proportional values) 1: memory functions on (freeze proportional values)	U8	ro	0	0	0	=
7	Freeze Bit 7	Not supported Memory status for the proportional outputs. 0: memory function off (release proportional values) 1: memory functions on (freeze proportional values)	U8	ro	0	0	0	=
8	Freeze Bit 8	Not supported Memory status for the proportional outputs. 0: memory function off (release proportional values) 1: memory functions on (freeze proportional values)	U8	ro	0	0	0	=
9	Button 1	0: Not Pressed 1: Pressed	U8	ro	0	1	0	=
10	Button 2	See Button 1 (Sub Index 9)	U8	ro	0	1	0	=
11	Button 3	See Button 1 (Sub Index 9)	U8	ro	0	1	0	=
12	Button 4	See Button 1 (Sub Index 9)	U8	ro	0	1	0	=
13	Button 5	See Button 1 (Sub Index 9)	U8	ro	0	1	0	=
14	Button 6	See Button 1 (Sub Index 9)	U8	ro	0	1	0	=
15	Button 7	See Button 1 (Sub Index 9)	U8	ro	0	1	0	=
16	Button 8	See Button 1 (Sub Index 9)	U8	ro	0	1	0	=
17	Button 9	See Button 1 (Sub Index 9)	U8	ro	0	1	0	=
18	Button 10	See Button 1 (Sub Index 9)	U8	ro	0	1	0	=
19	Button 11	See Button 1 (Sub Index 9)	U8	ro	0	1	0	=
20	Button 12	See Button 1 (Sub Index 9)	U8	ro	0	1	0	=
21	Button 13	See Button 1 (Sub Index 9)	U8	ro	0	1	0	=
22	Button 14	See Button 1 (Sub Index 9)	U8	ro	0	1	0	=
23	Button 15	See Button 1 (Sub Index 9)	U8	ro	0	1	0	=
24	Button 16	See Button 1 (Sub Index 9)	U8	ro	0	1	0	=
25	Button 17	See Button 1 (Sub Index 9)	U8	ro	0	1	0	=
26	Button 18	See Button 1 (Sub Index 9)	U8	ro	0	1	0	=
27	Button 19	See Button 1 (Sub Index 9)	U8	ro	0	1	0	=
28	Button 20	See Button 1 (Sub Index 9)	U8	ro	0	1	0	=
29	Button 21	See Button 1 (Sub Index 9)	U8	ro	0	1	0	=
30	Button 22	See Button 1 (Sub Index 9)	U8	ro	0	1	0	=
31	Button 23	See Button 1 (Sub Index 9)	U8	ro	0	1	0	=
32	Button 24	See Button 1 (Sub Index 9)	U8	ro	0	1	0	=
33	Button 1	0: Not Enabled 1: Enabled	U8	ro	0	1	0	=
34	Button 2	See Button 1 (Sub Index 33)	U8	ro	0	1	0	=
35	Button 3	See Button 1 (Sub Index 33)	U8	ro	0	1	0	=
36	Button 4	See Button 1 (Sub Index 33)	U8	ro	0	1	0	=
37	Button 5	See Button 1 (Sub Index 33)	U8	ro	0	1	0	=
38	Button 6	See Button 1 (Sub Index 33)	U8	ro	0	1	0	=

6020h Read input bit (buttons) (continued)

Sub-index	Name	Description	Data type	Access	Minimum	Maximum	Default	Unit/Scale
39	Button 7	See Button 1 (Sub Index 33)	U8	ro	0	1	0	=
40	Button 8	See Button 1 (Sub Index 33)	U8	ro	0	1	0	=
41	Button 9	See Button 1 (Sub Index 33)	U8	ro	0	1	0	=
42	Button 10	See Button 1 (Sub Index 33)	U8	ro	0	1	0	=
43	Button 11	See Button 1 (Sub Index 33)	U8	ro	0	1	0	=
44	Button 12	See Button 1 (Sub Index 33)	U8	ro	0	1	0	=
45	Button 13	See Button 1 (Sub Index 33)	U8	ro	0	1	0	=
46	Button 14	See Button 1 (Sub Index 33)	U8	ro	0	1	0	=
47	Button 15	See Button 1 (Sub Index 33)	U8	ro	0	1	0	=
48	Button 16	See Button 1 (Sub Index 33)	U8	ro	0	1	0	=
49	Button 17	See Button 1 (Sub Index 33)	U8	ro	0	1	0	=
50	Button 18	See Button 1 (Sub Index 33)	U8	ro	0	1	0	=
51	Button 19	See Button 1 (Sub Index 33)	U8	ro	0	1	0	=
52	Button 20	See Button 1 (Sub Index 33)	U8	ro	0	1	0	=
53	Button 21	See Button 1 (Sub Index 33)	U8	ro	0	1	0	=
54	Button 22	See Button 1 (Sub Index 33)	U8	ro	0	1	0	=
55	Button 23	See Button 1 (Sub Index 33)	U8	ro	0	1	0	=
56	Button 24	See Button 1 (Sub Index 33)	U8	ro	0	1	0	=

6401h Read analog inputs 16-Bit

Sub-index	Name	Description	Data type	Access	Minimum	Maximum	Default	Unit/Scale
0	Number of Analog Inputs 16-Bit		U8	ro	0	10	=	=
1	X-Axis Proportional		S16	ro	-1000	1000	0	%*10
2	Y-Axis Proportional		S16	ro	-1000	1000	0	%*10
3	Grip 1 Proportional		S16	ro	-1000	1000	0	%*10
4	Grip 2 Proportional		S16	ro	-1000	1000	0	%*10
5	Grip 3 Proportional		S16	ro	-1000	1000	0	%*10
6	Axis 5		S16	ro	-1000	1000	0	%*10
7	Axis 6		S16	ro	-1000	1000	0	%*10
8	Axis 7		S16	ro	-1000	1000	0	%*10
9	Axis 8		S16	ro	-1000	1000	0	%*10
10	Axis 9		S16	ro	-1000	1000	0	%*10

6404h Manufacturer specific input 2-Bit

Sub-index	Name	Description	Data type	Access	Minimum	Maximum	Default	Unit/Scale
0	Number of Mfg Specific Inputs 2-Bit		U8	ro	0	10	=	=
1	X-Axis Proportional Neutral State		U8	ro	0	3	0	00 – Neutral 01 – Out of Neutral 12 – Error 13 – Not Available
2	Y-Axis Proportional Neutral State		U8	ro	0	3	0	See Sub Index 1
3	Grip 1 Proportional Neutral State		U8	ro	0	3	0	See Sub Index 1
4	Grip 2 Proportional Neutral State		U8	ro	0	3	0	See Sub Index 1

6404h Manufacturer specific input 2-Bit (continued)

Sub-index	Name	Description	Data type	Access	Minimum	Maximum	Default	Unit/Scale
5	Grip 3 Proportional Neutral State		U8	ro	0	3	0	See Sub Index 1
6	Axis 5 Neutral State		U8	ro	0	3	0	See Sub Index 1
7	Axis 6 Neutral State		U8	ro	0	3	0	See Sub Index 1
8	Axis 7 Neutral State		U8	ro	0	3	0	See Sub Index 1
9	Axis 8 Neutral State		U8	ro	0	3	0	See Sub Index 1
10	Axis 9 Neutral State		U8	ro	0	3	0	See Sub Index 1

6405h Manufacturer specific reserved 16-Bit

Sub-index	Name	Description	Data type	Access	Minimum	Maximum	Default	Unit/Scale
0	Number of Mfg Specific Reserved 16- Bit		U16	ro	0	1	=	=
1	Reserved 1		U16	ro	0	$2_{16}-1$	0	

6406h Manufacturer specific reserved 2-Bit

Sub-index	Name	Description	Data type	Access	Minimum	Maximum	Default	Unit/Scale
0	Number of Mfg Specific Reserved 2- Bit		U8	ro	0	1	=	=
1	Reserved 1		U8	ro	0	3	0	

## Error handling

### General

When an event classified as an error occurs, a CANopen standard error code is sent out in an EMCY message. The emergency message and its contents are shown in the table below. The emergency message follows reference CiA Draft Standard 301, Version 4.0. Parts of the manufacturer specific error field are used for the more specified error definition.

### Emergency message

Byte	0	1	2	3	4	5	6	7
Content	Emergency error code		Error register	Manufacturer specific				

### Emergency error codes

#### CANopen failure code

Inputs	Voltage high		Voltage low		Not calibrated		Redundancy	
	Error code	Manufacturer specific	Error code	Manufacturer specific	Error code	Manufacturer specific	Error code	Manufacturer specific
X	0x3110	0x80	0x3120	0x80	0xFF10	0x80	0xFF20	0x80
Y	0x3110	0x81	0x3120	0x81	0xFF10	0x81	0xFF20	0x81
Grip X	0x3110	0x82	0x3120	0x82	0xFF10	0x82	0xFF20	0x82
Grip Y	0x3110	0x83	0x3120	0x83	0xFF10	0x83	0xFF20	0x83
Grip Theta	0x3110	0x84	0x3120	0x84	0xFF10	0x84	0xFF20	0x84

### Manufacturer specific error codes

The manufacturer specific error codes are used to help identify which sensor has experienced failure.

#### Manufacturer specific definition

Byte 0 occurrence counter	Byte 1 sensor identifier		Byte 2 not used	Byte 3 not used
0-127	Digital inputs	0x00 - 0x3F	0	0
0-127	Digital outputs	0x40 - 0x7F	0	0
0-127	Analog inputs	0x80 - 0xBF	0	0
0-127	Analog outputs	0xC0 - 0xFF	0	0

### Error register

The error register can also be read at index 1001h:0.

#### Standard error register (bit field) for the emergency message

Code	Bit	Value	Description
Generic	0	0	
Current	1	0	
Voltage	2	0	
Temperature	3	0	
Communication	4	0	
Device	5	0	
Reserved	6	0	
Manufacturer	7	0	



**Hydro-Gear**

www.hydro-gear.com

**Daikin-Sauer-Danfoss**

www.daikin-sauer-danfoss.com

Explore our solutions at [danfoss.com](http://danfoss.com).

Additional product literature is available at [powersource.danfoss.com](http://powersource.danfoss.com).

**Danfoss  
Power Solutions (US) Company**  
2800 East 13th Street  
Ames, IA 50010, USA  
Phone: +1 515 239 6000

**Danfoss  
Power Solutions GmbH & Co. OHG**  
Krokamp 35  
D-24539 Neumünster, Germany  
Phone: +49 4321 871 0

**Danfoss  
Power Solutions ApS**  
Nordborgvej 81  
DK-6430 Nordborg, Denmark  
Phone: +45 7488 2222

**Danfoss  
Power Solutions Trading  
(Shanghai) Co., Ltd.**  
Building #22, No. 1000 Jin Hai Rd  
Jin Qiao, Pudong New District  
Shanghai, China 201206  
Phone: +86 21 2080 6201

Danfoss can accept no responsibility for possible errors in catalogues, brochures and other printed material. Danfoss reserves the right to alter its products without notice. This also applies to products already on order provided that such alterations can be made without subsequent changes being necessary in specifications already agreed. All trademarks in this material are property of the respective companies. Danfoss and the Danfoss logotype are trademarks of Danfoss A/S. All rights reserved.