

Description

AME 110 is a high accuracy modulating control actuator, specifically designed for use in combination with the Pressure Independent Control Valve type AB-QM in sizes from DN 15-32.

The flow is modulated by the AB-QM pressure independent control valve to avoid overflow and reduced boiler and/or chiller efficiency.

The actuator with AB-QM is used to control water supply to fan coil units, chilled beams, induction units, small re-heaters, re-coolers, AHU's and other terminal units for zone control, in which heated/chilled water is the controlled medium. Due to its accuracy and LED indication, the AME 110 facilitates an accelerated commissioning process, allows easy maintenance, improves indoor comfort and increases energy savings. Control is achieved via voltage or current input signal to the actuator.

Features & benefits

- High position resolution and accuracy
- Power supply AC or DC
- LED bar displaying information on position, status and alarms
- Electronic calibration process with valve stroke detection
- No tools required for mounting
- Maintenance-free lifetime
- Broken wire and missing control signal detection, when using 2-10V/4-20mA mode
- Low-noise operation (on 12 s/mm)
- Harmonized halogen free cables
- IP54 in all orientations

Applications

- Radiant ceiling panels, supplied by 2 or 4 pipes (Heating supply and return or/and cooling supply and return).
- Fan coil units, with single coils supplied by 2 or 4 pipes (Heating supply and return or/and cooling supply and return).

Ordering

Product code numbers

Type	Supply voltage [V]	Control input signal Y [V]	Cable length [m]	Quantity per packing format	Code number
AME 110 NL 0-10V	24 V AC/DC	0(2) - 10 V	1.500	1	082H8110
AME 110 NLX 0-10V	24 V AC/DC	0(2) - 10 V	1.500	1	082H8114

*Industry pack versions (082H8118 - 082H8124) are a more environmentally friendly option. In addition to their lower price, they also generate less waste and reduce carbon emissions (by 3.4 tons of CO₂ compared to yearly sales of single packs). Whenever possible, choose the industry pack and help us minimize the environmental impact.









Functions



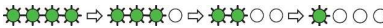



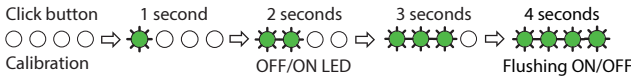
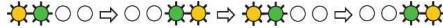

Operation

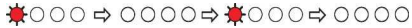
Commissioning

The factory setting of the actuator spindle is the fully stem up position, because of easier mechanical connection of the actuator to the valve. Each actuator is supplied with the connecting cable for the controller.

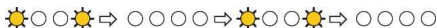
LED indication

Functionality	LED visual pattern	LED pattern
Calibration	 <p>Actuator is checking and calibrating to the mechanical stroke of the valve.</p>	Repetitive animation
Movement		
Retracting stem	 <p>Opening the AB-QM valve - Actuator stem is moving up to the retracted position.</p>	Repetitive animation
Extending stem	 <p>Closing the AB-QM valve - Actuator stem is moving down to the extended position.</p>	Repetitive animation
Position		
Stem fully extended - retracted 0% (AB-QM closed - 0% flow)	 <p>Stem retracted 50-74% (AB-QM open 50-74%)</p>	 <p>Constant - lit</p>
Stem retracted 1-24% (AB-QM open 1-24%)	 <p>Stem retracted 75-99% (AB-QM open 75-99%)</p>	 <p>Constant - lit</p>
Stem retracted 25-49% (AB-QM open 25-49%)	 <p>Stem fully retracted - 100% (AB-QM open 100%)</p>	 <p>Constant - lit</p>
Reset (button)	Press reset button, keep pressing until:	
Under 1 second = Calibration 2 seconds = Turn off/on LED indication 4 seconds = Flushing on/off	<p>Click button 1 second 2 seconds 3 seconds 4 seconds</p>  <p>Calibration OFF/ON LED Flushing ON/OFF</p>	One time animation
Flushing is active	 <p>Flushing gets rid of debris trapped under the valve cone. For 90 minutes the actuator will move the stem to the retracted position (AB-QM fully open).</p>	Repetitive animation

Functionality	LED visual pattern	LED pattern
Alarm / Error (actuator stops working)		
Error during calibration		Constant - blinking
	Verify if the actuator is correctly attached to the valve and recalibrate.	
Power supply fail		Constant - lit
	Power supply voltage was at a dangerous level (outside of ±20%), actuator stopped working.	
Motor is not working		Constant - blinking
	Motor has reached a point where it is not working anymore, due to damage or lifetime wear. Replacement is necessary.	
Internal error		Constant - blinking
	Internal error has been detected in the software. Cycle the power off and on. If the error persists actuator replacement may be necessary.	
Alarm / Warning (actuator still works)		
Valve stroke reduced		Lit
	Actuator detected shorter valve stroke. Flushing valve may solve the problem. Recalibration will adjust the actuator to the new shorter stroke.	
Internal temperature too high/low		Blinking
	Ambient temperature has likely exceeded 60°C or dropped below -15°C	
Valve setting conflict		Lit
	Measured valve stroke during calibration was too short. Check valve setting, adjust it and recalibrate afterwards.	
Missing Control Signal		Blinking
	In 2-10 V / 4-20 mA mode, missing signal or broken control wire was detected.	
Power supply outside limits		Lit
	Supply voltage is outside the allowed limit, check voltage levels.	
Forced position change		Blinking
	While under power, forced change in actuator position was detected. Recalibrate to clear the warning. Avoid moving the actuator under power.	

Blinking LED patterns have a 2 Hz frequency (blink twice per second)

Flowchart for LED bar display

This flowchart can be used to better understand the LED visuals. The LED bar is displaying a lot of information (movement, warning, position, error). In some cases it can be showing multiple things at once in a span of 10-20 seconds. There could be movement, two warnings and position, all shown one after the other.

There is always a pause between LEDs, when showing multiple warnings and/or movement. Only when an error occurs, this will be the only thing showing, because the actuator is not working correctly.

LED Bar Display

Question / Condition	Option	Action / Result	Duration of action	Next step
(1) Is there an error?	YES	(1 A) Show error	3 sec	(1) Is there an error?
	NO	(2) Is there a warning?	-	YES → (2 A) Show warning NO → (4) Is the actuator moving?
(2) Is there a warning?	YES	(2 A) Show warning	3 sec	(3) Is there another warning?
	NO	(4) Is the actuator moving?	-	(4 A) Show movement (4 B) Show position
(3) Is there another warning?	YES	(3 A) Show warning	3 sec	(4) Is the actuator moving?
	NO	(4) Is the actuator moving?	-	(4 A) Show movement (4 B) Show position
(4) Is the actuator moving?	YES	(4 A) Show movement	3 sec	(1) Is there an error?
	NO	(4 B) Show position	3 sec	(1) Is there an error?

Visual representation of LED bar display

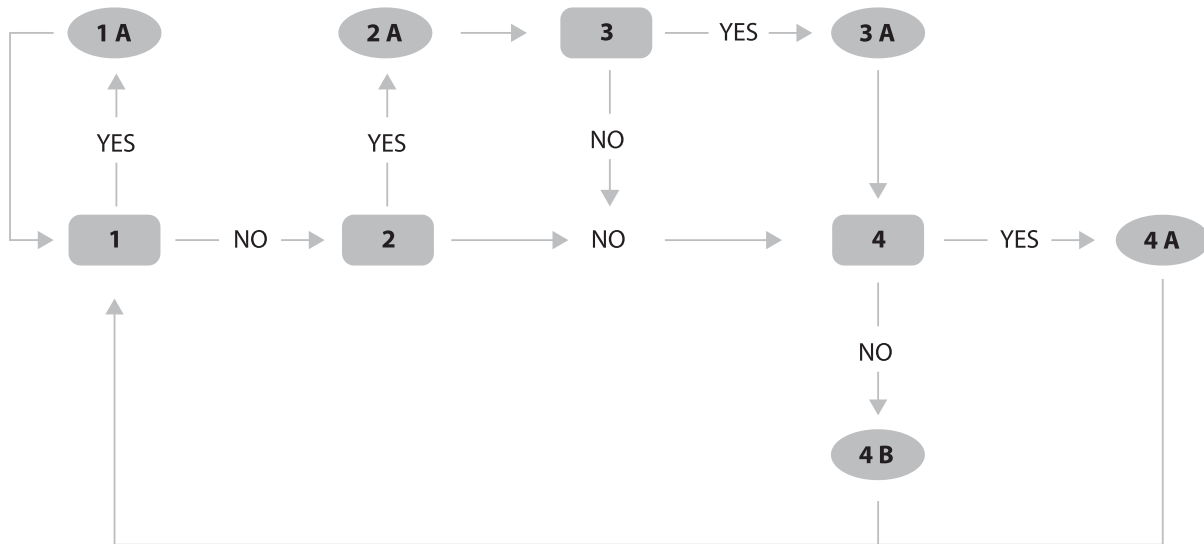

Settings

DIP Switch Setting

(for commissioning purposes only)

The actuator has a function selection DIP switch under the removable cover. The switch provides the following functions:

• DIP 1:

U/I - Input signal type selector

If set to OFF position, voltage input is selected. If set to ON position, current input is selected.

• DIP 2:

0/2 - Input signal range selector

If set to OFF position, the input signal is in the range from 0-10 V (voltage input) or from 0-20 mA (current input). If set to ON position, the input signal is in the range from 2-10 V (voltage input) or from 4-20 mA (current input).

• DIP 3:

D/I - Direct or inverse acting selector

If set to OFF position, the actuator is direct acting (stem retracts as voltage increases). If the actuator is set to ON position, the actuator is inverse acting (stem extends as voltage increases).

• DIP 4:

NORMAL/FAST - Speed selector

If set to OFF position, the normal actuating speed 12 s/mm is selected. If set to ON position, the faster actuating speed 3 s/mm is selected.

• DIP 5:

LOG/LIN - Equal percentage (LOG) or linear flow through valve selector

If set to OFF position, the flow through the valve is equal percentage-wise according to the control signal. If set to ON position, the valve position is linear according to the control signal.

• DIP 6:

---/ASTK - Anti-sticking function

If set to OFF position (---), the function is disabled. If set to ON position (ASTK), the periodical valve motion is switched on. The actuator moves up and down 2 mm and exercises the valve every 7 days. It moves the valve to avoid blocking in periods when the heating/cooling is off.

• **Reset button:**

If the reset button is only pressed shortly (click) for less than 1 second, the actuator will go into calibration procedure. If the reset button is pressed and held for 2 seconds, you can switch between LED indication or NO LED indication (except errors/warnings). If reset is held for 4 seconds, the Flushing mode is activated. It will fully open the valve for 90 minutes, to clear debris from the valve or enable flushing of the system.

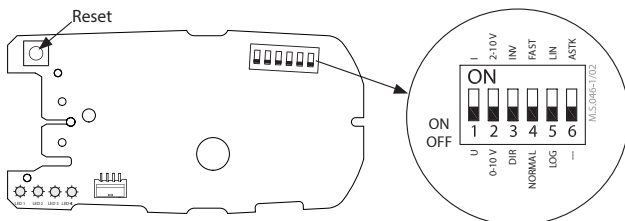

Remark:

Factory setting: All switches are in OFF positions.

Manual override

(for service purposes only)



Caution:

Do not manually operate the drive if power is connected!

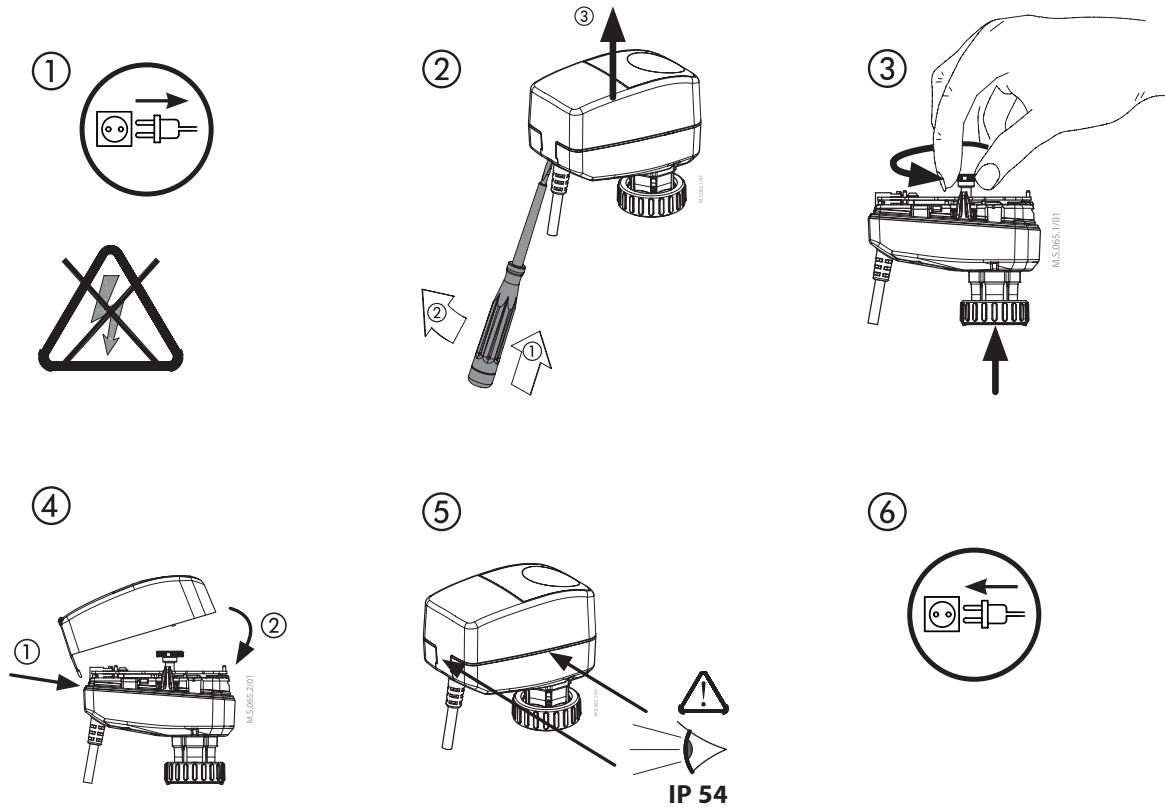

1. Disconnect the power supply
2. Remove the cover
3. Use the manual operation knob to move the actuator up/down
4. Put back the cover
5. Make sure the power cable and cover are in the correct position (improper installation can affect the IP54 rating)
6. Reconnect the power supply

Product details

General data

Technical data

Type			AME 110 NL	AME 110 NLX
Power supply		V	24 AC/DC; $\pm 20\%$	
Power consumption	running	W	1.2 W (DC)/2.9 VA (AC) @ 12 s/mm 1.4 W (DC)/3.4 VA (AC) @ 3 s/mm	
	standby		0.4 W (DC)/1.1 VA (AC) @ 12 and 3 s/mm	
Frequency		Hz	50/60	
Control input Y		V	0-10 (2-10) Ri = 110 k Ω	
		mA	0-20 (4-20) Ri = 500 Ω	
Feedback signal X		V	/	0-10V (2-10V); ± 0.1 V
Nominal closing force		N	150*	
Stroke		mm	7.5	
Stroke resolution range		Steps	4000 steps (at 100% valve setting) - control signal resolution limit 450 steps (at 10% valve setting) - shortest valve stroke resolution	
Position Accuracy		mm	± 0.1	
Speed		s/mm	default 12 s/mm, selectable 3 s/mm	
Relative humidity			95% r.h., non-condensing (according to EN 60730-1)	
Max. medium temperature		°C	95	
Ambient temperature			-10 ... 55**	
Storage and transport temperature			-40 ... 70	
Protection class			II	
Grade of enclosure			IP 54 (all positions)	
Weight		kg	0.3	

* When used at temperatures below 0°C, the closing force may in some worst cases drop to minimum 120N. For AB-QM valves this is still above requirement, but consider if using the actuator on other valves besides AB-QM.

** Can be used below 2°C of medium or ambient temperature, if ice forming on the spindle is prevented. The valve and actuator neck should be insulated with vapor tight insulation, or use a stem heater to prevent condensation.

Capacity

Input/Output

Control signal

The control signal (Y) must be connected to the grey wire, which controls the actuator to open or close the valve (and in-between positions).

By adjusting DIP switch No. 2, the control signal can be configured to either Voltage (0-10 V) or Current (0-20 mA) mode. To ensure the valve can provide full flow and no leakage (0-100%), the control signal is designed with two specific zones that guarantee the actuator reaches its fully open and fully closed positions.

This means voltage in the zone below 0.12 V the actuator will be fully closed and above 9.88 V will be fully open. The design ensures that even in the presence of signal "noise," the full valve stroke can be controlled.

Feedback signal

The 0-10 V feedback signal (X - blue wire) is available in the NLX versions of the actuator. This signal provides direct feedback in the form of voltage (0-10 V) signal, conveying the actuator's current position to the DDC system. When the control voltage (Y) changes, the actuator may take a few seconds (up to a minute, depending on the size of the change) to reach the new position.

After the actuator movement, both the control (Y) and feedback (X) signals should be aligned.

This indicates that the actuator has reached the desired position and adjusted the valve flow.

Equal-percentage (LOG) or Linear

By default, the actuator operates with an equal percentage characteristic (LOG) setting, which ensures optimal performance in water-to-air applications. However, by switching DIP switch No. 5 to the "ON" position, the actuator switches to a linear characteristic mode.

The actuator's feedback signal is always linear (matching the control signal) and is not directly correlated to the valve position, regardless of the setting of DIP switch No. 5.

Additionally, when DIP switch No. 2 is set to the "ON" position, the feedback signal will operate within a 2-10 V range.

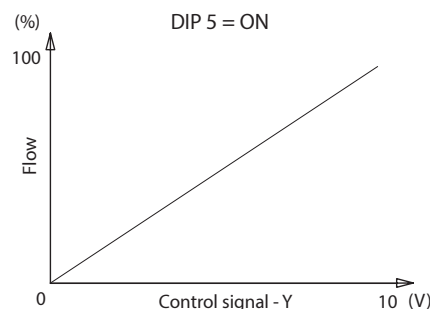
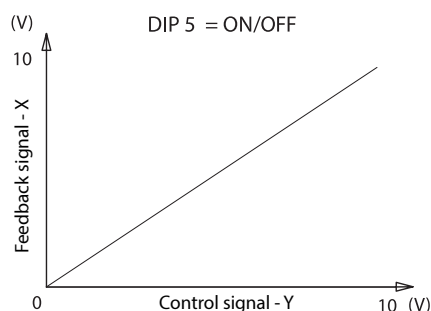
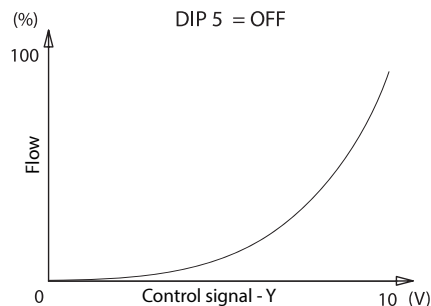

Dimensions

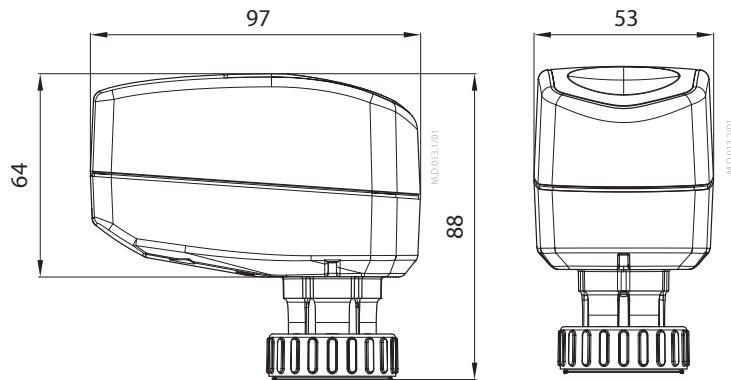

Installation

Mechanical

The actuator should be mounted with the valve stem in either horizontal position or pointing upwards.

The actuator is fixed to the valve body by means of a mounting ring, which requires no tools for mounting. The ring should be tightened by hand.

Electrical

Important: It is strongly recommended that the mechanical installation is completed before the electrical installation.

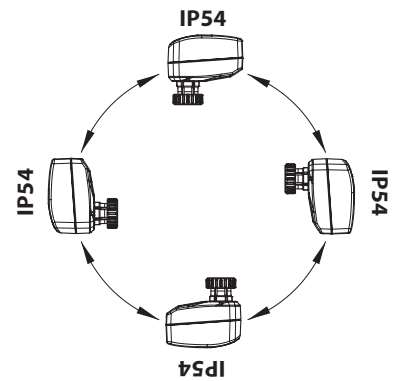

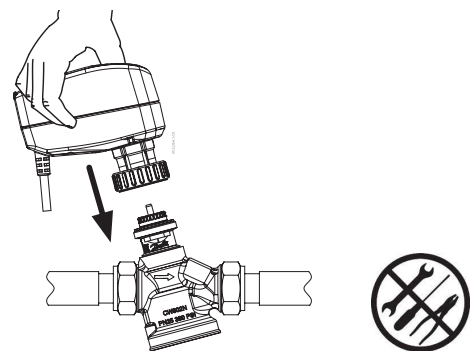

Installation procedure

1. Check the valve neck, the valve setting should be set before mounting the actuator.
2. The actuator must be in the factory position (stem up), then mount it securely on the valve body.
3. Wire the actuator according to the wiring diagram
4. The direction of the stem movement can be observed on the LED indication

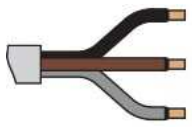

Wiring

AME 110 NL			
	Black	Common (-)	
	Brown	24 V (+)	
	Grey	Y - control signal (0-10 V)	

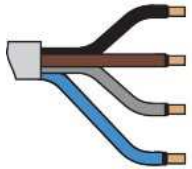
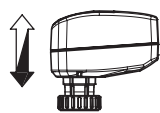
AME 110 NLX			
	Black	Common (-)	
	Brown	24 V (+)	
	Grey	Y - control signal (0-10 V)	
	Blue	X - feedback signal (0-10 V)	

Calibration

1. On the first “wake up” (or power reset or press of the reset button), the actuator will go into calibration procedure and adjust the stroke of the actuator according to the valve stroke.
2. If actuator AME 110 NL/NLX is charged by 24 V supply voltage and if it is not installed on AB-QM valve, it will cause a failed calibration (visible by an alarm on LEDs)
3. **In case the calibration is not done, the actuator will move to the upper position. This way it can be easily mounted on the valve, if it has not been on the last attempt**
4. Re-calibration is started by pressing the RESET button or by cycling the power supply

Certificates, declarations and approvals

The list contains all certificates, declarations, and approvals for this product type. Individual code number may have some or all of these approvals, and certain local approvals may not appear on the list.

When you click on the link you will be directed to the latest version of the ‘Declaration of Conformity’. Products developed and sold before this date of issue conform to the directives/standards in force at the time of their sale.

Approval type	Title	Certification body	Approval topic
EU Declaration	Danfoss EU 221011EN0815101.04	Danfoss	LVD, EU RoHS
Export Control Declaration	Gear and Thermal actuators	Danfoss	
Manufacturer's Declaration	Manufacturers declaration EU BAC 240926en2816101 Rev.01	Danfoss	Eu.bac
Manufacturer's Declaration	Declaration of Energy Classes (BACS) - EN ISO 52120-1 and EN ISO 16484-4	Danfoss	Compliance misc. Standards



Tender text

AME 110 is a high-performance actuator for commercial HVAC applications. It offers precise water flow control, enhancing system efficiency and occupant comfort. Designed for seamless integration with Danfoss AB-QM valves, room controllers and advanced building management systems (BMS), the AME 110 NL/NLX stands out for its unique features that optimize performance and reliability.

Mechanical Specifications:

Nominal Force: 150 N
Stroke Length: 7.5 mm
Operation Type: Modulating
Resolution: Min. 450 steps (at 10% valve setting)
Position Accuracy: ± 0.1 mm
Speed of the actuator: 12 or 3 s/mm. providing flexibility in valve control

Electrical Specifications:

Power Supply: 24V AC/DC, 50/60 Hz.
Power Consumption: 1 W DC, 1.1 VA AC
Control Signal: 0(2)-10V DC or 0(4)-20mA, providing flexibility in system integration
Feedback Signal for NLX versions: 0(2)-10V DC, enabling accurate monitoring of valve position

Features:

Logarithmic and linear characteristic settings available in the same product allowing for optimized control based on your specific application requirements.

Calibration: Automatic electronic calibration on power up to detect the opening and closing point of the valve.

Anti-Blocking/Sticking Function: Our gear actuator incorporates a selectable anti-blocking/ sticking function, preventing valve blockages, ensuring smooth and reliable operation.

Actuator Mode Signaling: The actuator features LED signaling to indicate its operating mode, including running, standby, calibrate, and error modes, enabling quick and easy troubleshooting.

Direct or inverse acting actuator, allows for easy selection between direct or inverse acting modes, adapting to different control system requirements.

Manual Override Operation: In the event of power failure or maintenance, the actuator can be manually operated, ensuring continuous valve control.

Environmental Conditions:

Operating Temperature Range: -10°C to $+55^{\circ}\text{C}$
Protection Class: IP54, providing protection against dust and water ingress from all directions, ensuring durability and longevity.
This enables mounting of the AB-QM valves in all directions.
Humidity: 5% to 95% RH, non-condensing.

Compatibility:

Valve Types: Specifically designed for Danfoss Pressure Independent Control Valves, type AB-QM.
Halogen-Free Cable: The actuator comes with a 1.5 m halogen-free cable as standard. Additional cable lengths of 2.5 m and 5 m are available.

Compliance and Standards:

EMC Directive 2014/30/EU EN 60730-1, EN 60730-2-14
RoHS 2011/65/EU standard EN IEC 63000
Low Voltage Directive - safety assurance is checked according to EN 60730-1, EN 60730-2-14

Contact details

Online support

Danfoss offers a wide range of support along with our products, including digital information, software, mobile apps and expert guidance. See the possibilities below.



The Danfoss Design center

Discover the Design Center, our advanced digital platform that streamlines product selection. With integrated tools and enhanced type pages, it's simpler than ever to access product information and documentation, and to select the right products. Check the availability of Danfoss products at partner locations and enjoy seamless transitions from selection to purchase with our basket-to-basket functionality. Whether you're buying from our distributors or directly from the Product Store, the Design Center simplifies your experience. Learn more at: designcenter.danfoss.com.



The Danfoss product store

The Danfoss Product Store is a one-stop shop available 24/7 for our customers, no matter where you are in the world or what area of industry you work in. Browse our catalog, check product details and documentation, view your prices and product availability, and quickly finalize your purchase. Start browsing at: store.danfoss.com.



Danfoss Partner Portal/Product Data tool

Designed to support you with easy access to product data extracts, essential resources, tools, and information. The Partner Portal provides a centralized hub for product documentation, training materials, marketing assets, and technical support, ensuring you have everything you need to succeed and grow your business with Danfoss. The Partner Portal is available 24/7 at: partner.danfoss.com and is ready to support your business.



Find technical documentation

Find technical documentation you need to get your project up running. Get direct access to our official collection of data sheets, certificates and declarations, manuals and guides, 3D models and drawings, case stories, brochures, and much more. Start searching now at: documentation.danfoss.com.



Danfoss Learning

Danfoss Learning is a free online learning platform. It features courses and materials specifically designed to help engineers, installers, service technicians, and wholesalers better understand the products, applications industry topics, and trends that will help you do your job better. Find your local Danfoss website here: learning.danfoss.com.



Get local information and support

Local Danfoss websites are the main sources for help and information about our company and products. Find product availability, get the latest regional news, or connect with a nearby expert - all in your own language. Find your local Danfoss website here: danfoss.com.

Danfoss A/S

Climate Solutions . danfoss.com . +45 7488 2222

Any information, including, but not limited to information on selection of product, its application or use, product design, weight, dimensions, capacity or any other technical data in product manuals, catalogues description, advertisements, etc. and whether made available in writing, orally, electronically, online or via download, shall be considered informative, and is only binding if and to the extent, explicit reference is made in a quotation or order confirmation. Danfoss cannot accept any responsibility for possible errors in catalogues, brochures, videos and other material. Danfoss reserves the right to alter its products without notice. This also applies to products ordered but not delivered provided that such alterations can be made without changes to form, fit or function of the products. All trademarks in this material are property of Danfoss A/S or Danfoss group companies. Danfoss and the Danfoss logo are trademarks of Danfoss A/S. All rights reserved.
