



iC2-Micro Frequency Converters

1 Introduction

This operating guide provides necessary information for qualified personnel to install and commission the drive. Read and follow the instructions to use the drive safely and professionally.

Do not dispose of equipment containing electrical components together with domestic waste. Collect it separately in accordance with local and currently valid legislation.

2 Safety

Pay particular attention to the safety instructions and general warnings to avoid the risk of death, serious injury, and equipment or property damage.

WARNING

HIGH VOLTAGE

Drives contain high voltage when connected to AC mains input, DC supply, or load sharing.

- To avoid electric shock, the IP20 drive must be installed in a cabinet or with an IP21 conversion kit.

UNINTENDED START

The motor may start from control panel, I/O inputs, fieldbus, or MyDrive® Insight at any time, when the drive is connected to the AC mains, DC supply, or load sharing.

DISCHARGE TIME

The drive contains DC-link capacitors, which can remain charged even when the drive is not powered. High voltage can be present even when the warning indicator lights are off.

- Stop the motor, disconnect AC mains and permanent magnet type motors, and remove DC-link supplies, including battery backups, UPS, and DC-link connections to other drives.

- Wait for the capacitors to discharge fully and measure it before performing any service or repair work.

- The minimum waiting time is 4 minutes for MA01c-MA02c and MA01a-MA03a drives, and 15 minutes for MA04a-MA05a drives.

LEAKAGE CURRENT

Leakage currents of the drive exceed 3.5 mA. Make sure that the minimum size of the ground conductor complies with the local safety regulations for high touch current equipment.

3 Installation

3.1 Mechanical Dimensions

Enclosure size	Height [mm (in)]		Width [mm (in)]		Depth [mm (in)] ⁽¹⁾	Mounting holes [mm (in)]	
	H	H1 ⁽²⁾	W	w			
MA01c	150 (5.9)	216 (8.5)	140.4 (5.5)	70 (2.8)	55 (2.2)	143 (5.6)	4.5 (0.18)
MA02c	176 (6.9)	232.2 (9.1)	150.5 (5.9)	75 (3.0)	59 (2.3)	157 (6.2)	4.5 (0.18)
MA01a	150 (5.9)	202.5 (8.0)	140.4 (5.5)	70 (2.8)	55 (2.2)	158 (6.2)	4.5 (0.18)
MA02a	186 (7.3)	240 (9.4)	176.4 (6.9)	75 (3.0)	59 (2.3)	175 (6.9)	4.5 (0.18)
MA03a	238.5 (9.4)	291 (11.5)	226 (8.9)	90 (3.5)	69 (2.7)	200 (7.9)	5.5 (0.22)
MA04a	292 (11.5)	365.5 (14.4)	272.4 (10.7)	125 (4.9)	97 (3.8)	244.5 (9.6)	7.0 (0.28)
MA05a	335 (13.2)	396.5 (15.6)	315 (12.4)	165 (6.5)	140 (5.5)	248 (9.8)	7.0 (0.28)

1) The potentiometer on the local control panel extends 6.5 mm (0.26 in) from the drive.
2) Including decoupling plate.

3.2 Mounting Clearance

Enclosure size	Minimum mounting clearance [maximum temperature 50 °C (122 °F)]
All enclosure sizes	Above and below: 100 mm (3.9 in)
MA01a-MA05a, MA02c	Sides: 0 mm (0 in)
MA01c (natural cooling)	Sides: 0 mm (0 in) for 40 °C (104 °F), 10 mm (0.39 in) and above for 50 °C (122 °F)

3.3 Connecting to Mains and Motor

- Mount the ground wires to the PE terminal.
- Connect motor to terminals U, V, and W.
- Mount mains supply to terminals L1/L, L2, and L3/N (3-phase) or L1/L and L3/N (single-phase) and tighten.
- For required maximum screwing torque, see the back of the terminal cover.

3.4 Load Sharing/Brake

Load sharing	-UDC and +UDC/+BR
Brake	-BR and +UDC/+BR

- For MA01a, MA02a, and MA03a drives, wire with recommended connector (Ultra-Pod Fully Insulated FASTON Receptacles and Tabs, 521366-2, TE connectivity).
- For other enclosure sizes, mount the wires to the related terminal and tighten. For required maximum screwing torque, see the back of the terminal cover.
- For more details, contact Danfoss or refer to the drive's design guide.

NOTICE

Voltage levels of up to 850 V DC may occur between terminals +UDC/+BR and -UDC. Not short-circuit protected.

3.5 Control Terminals

- All control cable terminals are located underneath the terminal cover on the front of the drive.

- See the back of the terminal cover for outlines of control terminals and switches.

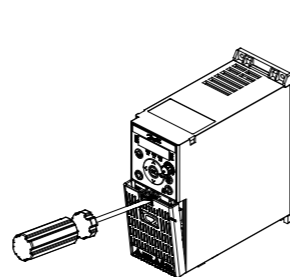

Figure 1: Removing Terminal Cover with a Screwdriver

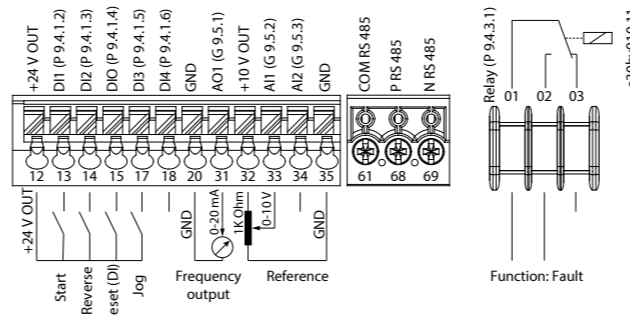

Figure 2: Overview of Control Terminals in PNP-configuration with Factory Setting (Speed Control Mode)

3.6 RJ45 Port and RS-485 Termination Switch

The drive has an RJ45 port which complies with Modbus 485 protocol.

The RJ45 port is used for connecting:

- External control panel (Control Panel 2.0 OP2)
- PC tool (MyDrive® Insight) via Quick Adapter USB-C/RJ45 OAX00

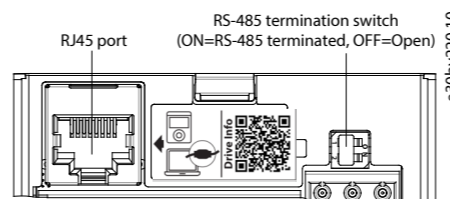

NOTICE

- The RJ45 port supports up to 3 m (9.8 ft) of shielded CAT5e cable which is NOT used to directly connect the drive to a PC. Failure to follow this notice damages the PC.
- RS-485 termination switch should be set to ON if the drive is at the end of the fieldbus.
- Do not operate the RS-485 termination switch when the drive is powered on.

4 Programming

4.1 Control Panel

Name	Function
Home/Menu	(1) Toggles between status view and main menu. (2) Long press to access the shortcut menu for quickly reading and editing parameters.
Up/Down	Switches status/parameter group/parameter numbers, and tunes the parameter values.
Left	Moves the cursor 1 bit to the left.
Back	Navigates to the previous step in the menu structure or cancels the setting during tuning parameter values.
OK	Confirms the operation.
Remote/Local	Toggles between the remote mode and local mode.
Start	Starts the drive in local mode.
Stop/Reset	Stops the drive in local mode, or resets the drive to clear a fault.
Potentiometer	Changes the reference value when the reference value is selected as potentiometer.

Table 1: Status and Operating Indicator Lights

Name	Function	Name	Function
MON	On: Shows the drive status.	REV	On: The drive is in reverse direction.
PGM	On: The drive is in programming status.	Off:	The drive is in forward direction.
TOR	On: The drive is in torque mode.	ST2	Refer to Table 3.
Off:	The drive is in speed mode.	WARN	Steadily lit when a warning occurs.
LOC	On: The drive is in local mode.	READY	Steadily lit when the drive is ready.
Off:	The drive is in remote mode.	FAULT	Flashes when a fault occurs.

Table 2: Run Indicator Light

Name	Function
RUN	On: The drive is in normal operation. Off: The drive has stopped.
Flash:	In the motor-stopping process; or the drive received a RUN command, but no frequency output.

Table 3: Multiple Setups Indicator Light

ST2	Off	On	Flash	Flash quickly
Active setup ⁽¹⁾	Setup 1	Setup 2	Setup 1	Setup 2
Programming setup ⁽²⁾	Setup 1	Setup 2	Setup 2	Setup 1

1) Select active setup in parameter P 6.6.1 Active Setup.
2) Select programming setup in parameter P 6.6.2 Programming Setup.

4.2 Operation with Control Panel

After the drive is powered up, press the [Home/Menu] button to toggle between status display and main menu. Use the [Up/Down] buttons to select items, and press the [OK] button to confirm selection.

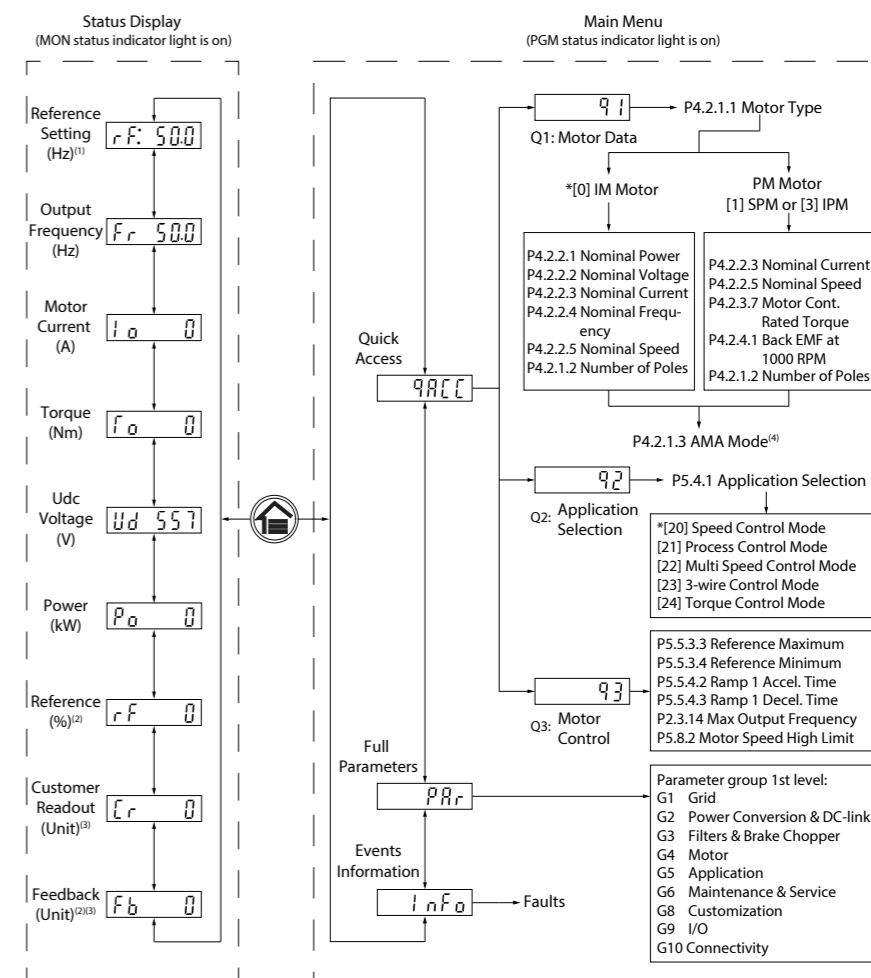

Note: (1) Local mode only. (2) Remote mode only. (3) The status is only shown when the corresponding function is enabled. (4) For AMA execution, refer to chapter Automatic Motor Adaptation (AMA). If parameter P 5.4.3 Motor Control Principle is set as [0] U/f, no need to execute AMA.

4.3 Automatic Motor Adaptation (AMA)

- Via running AMA in VVC+ mode, the drive builds a mathematical model of the motor to optimize compatibility between drive and motor, and thus enhances the motor control performance.
- Some motors may be unable to run the complete version of the test. In that case, select [2] Enable Reduced AMA in parameter P 4.2.1.3 AMA Mode.
- The AMA completes within 5 minutes. For best results, run the following procedure on a cold motor.
 - Set motor data according to the motor nameplate.
 - If needed, set motor cable length in parameter P 4.2.1.4 Motor Cable Length.
 - Set [1] Enable Complete AMA or [2] Enable Reduced AMA for parameter P 4.2.1.3 AMA Mode, and the main display shows To start AMA.
 - Press the [Start] button. The test runs automatically and the main display indicates when it is completed.
 - When AMA is completed, press any button to exit and return to normal operation mode.

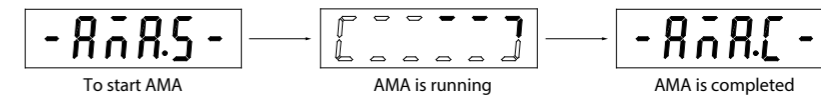

5 Troubleshooting

Table 4: Warning and Fault Events Summary

Number	Description	Warning	Fault	Trip lock	Cause
2	Live Zero Error	X	X	-	Signal on terminal 33 or 34 is less than 50% of the value set in P 9.5.2.3 T33 Low Voltage, P 9.5.2.5 T33 Low Current, P 9.5.3.3 T34 Low Voltage, and P 9.5.3.5 T34 Low Current.
3	No Motor	X	X	-	No motor has been connected to the output of the drive.
4	Mains Phase Loss ⁽¹⁾	X	X	X	Missing phase on the supply side, or the voltage imbalance is too high. Check the supply voltage.
7	DC Over Voltage ⁽¹⁾	X	X	-	DC-link voltage exceeds the limit.
8	DC Under Voltage ⁽¹⁾	X	X	-	DC-link voltage drops below the voltage warning low limit.
9	Inverter Overloaded	X	X	-	More than 100% load for too long.
10	Motor ETR Overtemperature	X	X	-	The motor is too hot due to more than 100% load for too long.
11	Motor Thermistor Overtemperature	X	X	-	The thermistor or thermistor connection is disconnected, or the motor is too hot.
12	Torque Limit	X	X	-	Torque exceeds the value set in either P 5.10.1 Motor Torque Limit or P 5.10.2 Regenerative Torque Limit.

Table 4: Warning and Fault Events Summary- (continued)

Number	Description	Warning	Fault	Trip lock	Cause
13	Over Current	X	X	X	Inverter peak current limit is exceeded. If this fault occurs on power-up, check whether power cables are mistakenly connected to the motor terminals.
14	Earth Fault	X	X	X	Discharge from output phases to ground.
16	Short Circuit	–	X	X	Short circuit in motor or on motor terminals.
17	Control Word Time-out	X	X	–	No communication to the drive.
18	Start Failed	–	X	–	May be caused by a blocked motor.
25	Brake Resistor Short	–	X	X	Brake resistor is short-circuited, thus the brake function is disconnected.
26	Brake Overload	X	X	–	The power transmitted to the brake resistor over the last 120 s exceeds the limit. Possible corrections: Decrease brake energy via lower speed or longer ramp time.
27	Brake IGBT/Brake chopper Short Circuited	–	X	X	Brake transistor is short-circuited, thus brake function is disconnected.
28	Brake Check	–	X	X	Brake resistor is not connected/working.
30	U phase loss	–	X	X	Motor phase U is missing. Check the phase.
31	V phase loss	–	X	X	Motor phase V is missing. Check the phase.
32	W phase loss	–	X	X	Motor phase W is missing. Check the phase.
36	Mains Failure	X	X	–	This warning/fault is only active if the supply voltage to the drive is less than the value set in P 2.3.7 Power Loss Controller Limit , and P 2.3.6 Power Loss Action is NOT set to [0] No Function .
38	Internal Fault	–	X	X	Contact the local supplier.
40	Overload T15	X	–	–	Check the load connected to terminal 15 or remove short-circuit connection.
46	Gate drive Voltage Fault	–	X	X	–
47	24 V Supply Low	X	X	X	24 V DC may be overloaded.
50	AMA calibration failed	–	X	–	A calibration error has occurred.
51	AMA check U _{nom} and I _{nom}	–	X	–	Wrong setting for motor voltage and/or motor current.
52	AMA low I _{nom}	–	X	–	Motor current is too low. Check the settings.
53	AMA big motor	–	X	–	The power size of the motor is too large for the AMA to operate.
54	AMA small motor	–	X	–	The power size of the motor is too small for the AMA to operate.
55	AMA parameter range	–	X	–	The parameter values of the motor are outside of the acceptable range. AMA does not run.
56	AMA interrupt	–	X	–	The AMA is interrupted.
57	AMA timeout	–	X	–	–
58	AMA internal	–	X	–	Contact the local supplier.
59	Current Limit	X	X	–	The drive is overloaded.
60	External Interlock	–	X	–	External interlock has been activated.
61	Feedback Error	X	X	–	–
63	Mechanical Brake Low	–	X	–	Actual motor current has not exceeded release brake current within start delay time window.
69	Power Card Temp	X	X	X	The cutout temperature of the power card has exceeded the upper limit.
80	Drive Initialized	–	X	–	All parameter settings are initialized to default settings.
87	Auto DC brake	X	–	–	Occurs in IT mains when the drive coasts, and the DC voltage is higher than 830 V for 400 V units and 425 V for 200 V units. The motor consumes energy on the DC link. This function can be enabled/disabled in P 2.3.13 Auto DC Braking .
95	Lost load detected	X	X	–	–
99	Locked Rotor	–	X	–	Rotor is blocked.
126	Motor Rotating	–	X	–	PM motor is rotating when AMA is performed.
127	Back EMF too High	X	–	–	The back EMF of PM motor is too high before starting.
Err. 89	Parameter read only	–	–	–	Parameters cannot be changed.
Err. 95	Not while running	–	–	–	Parameters can only be changed when the motor is stopped.
Err. 96	A wrong password was entered	–	–	–	Occurs when using a wrong password for changing a password-protected parameter.

1) These faults may be caused by mains distortions. Installing a line filter may rectify this problem.

6 Specifications

Table 5: Mains Supply 1x100–120 V AC (Normal overload 150% for 1 minute)

Frequency converter	02A4	04A8
Typical shaft output [kW (hp)]	0.37 (0.5)	1.1 (1.5)
Enclosure size	MA01c	MA02c
Output current		
Continuous (3x200–240 V AC) [A]	2.4	4.8
Intermittent (3x200–240 V AC) [A]	3.6	7.2

Table 5: Mains Supply 1x100–120 V AC (Normal overload 150% for 1 minute)

Maximum cable size (Mains, motor) [mm ² /AWG]	4/10		
Maximum input current			
Continuous (1x100–120 V) [A]	11.6	25.6	
Intermittent (1x100–120 V) [A]	17.4	38.4	
EMC filter type	C4		

Table 6: Mains Supply 1x200–240 V AC (Normal overload 150% for 1 minute)

Frequency converter	02A2	04A2	06A8	09A6
Typical shaft output [kW (hp)]	0.37 (0.5)	0.75 (1.0)	1.5 (2.0)	2.2 (3.0)
Enclosure size	MA01c	MA01c	MA02c	MA02a
Output current				
Continuous (3x200–240 V AC) [A]	2.2	4.2	6.8	9.6
Intermittent (3x200–240 V AC) [A]	3.3	6.3	10.2	14.4
Maximum cable size (Mains, motor) [mm ² /AWG]	4/10			
Maximum input current				
Continuous (1x200–240 V) [A]	6.1	11.6	18.7	26.4
Intermittent (1x200–240 V) [A]	8.3	15.6	26.4	37
EMC filter type	C1/C4			

Table 7: Mains Supply 3x200–240 V AC (Normal overload 150% for 1 minute)

Frequency converter	02A4	04A2	07A8	11A0	15A2	24A2	31A0	46A2
Typical shaft output [kW (hp)]	0.37 (0.5)	0.75 (1.0)	1.5 (2.0)	2.2 (3.0)	3.7 (5.0)	5.5 (7.5)	7.5 (10)	11 (15)
Enclosure size	MA01a	MA01a	MA02a	MA03a	MA03a	MA04a	MA04a	MA05a
Output current								
Continuous (3x200–240 V AC) [A]	2.4	4.2	7.8	11	15.2	24.2	31	46.2
Intermittent (3x200–240 V AC) [A]	3.6	6.3	11.7	16.5	22.8	36.3	46.5	69.3
Maximum cable size (Mains, motor) [mm ² /AWG]	4/10				16/6			
Maximum input current								
Continuous (3x200–240 V) [A]	3.8	6.7	12.5	17.7	24.3	33	42	42
Intermittent (3x200–240 V) [A]	5.7	8.3	18.8	26.6	35.3	49.5	63	63
EMC filter type	C4							

Table 8: Mains Supply 3x380–480 V AC (Normal overload 150% for 1 minute), MA01a–MA02a

Frequency converter	01A2	02A2	03A7	05A3	07A2	09A0
Typical shaft output [kW (hp)]	0.37 (0.5)	0.75 (1.0)	1.5 (2.0)	2.2 (3.0)	3.0 (4.0)	4.0 (5.5)
Enclosure size	MA01a	MA01a	MA01a	MA02a	MA02a	MA02a
Output current						
Continuous (3x380–440 V) [A]	1.2	2.2	3.7	5.3	7.2	9.0
Intermittent (3x380–440 V) [A]	1.8	3.3	5.6	8.0	10.8	13.7
Continuous (3x440–480 V) [A]	1.1	2.1	3.4	4.8	6.3	8.2
Intermittent (3x440–480 V) [A]	1.7	3.2	5.1	7.2	9.5	12.3
Maximum cable size (Mains, motor) [mm ² /AWG]	4/10					
Maximum input current						
Continuous (3x380–440 V) [A]	1.9	3.5	5.9	8.5	11.5	14.4
Intermittent (3x380–440 V) [A]	2.6	4.7	8.7	12.6	16.8	20.2
Continuous (3x440–480 V) [A]	1.7	3.0	5.1	7.3	9.9	12.4
Intermittent (3x440–480 V) [A]	2.3	4.0	7.5	10.8	14.4	17.5
EMC filter type	C2/C4					

Table 9: Mains Supply 3x380–480 V AC (Normal overload 150% for 1 minute), MA03a–MA05a

Frequency converter	12A0	15A5	23A0	31A0	37A0	43A0
Typical shaft output [kW]	5.5 (7.5)	7.5 (10)	11 (15)	15 (20)	18.5 (25)	22 (30)
Enclosure size	MA03a	MA03a	MA04a	MA04a	MA05a	MA05a
Output current						
Continuous (3x380–440 V) [A]	12	15.5	23	31	37	43
Intermittent (3x380–440 V) [A]	18	23.5	34.5	46.5	55.5	64.5
Continuous (3x440–480 V) [A]	11	14	21	27	34	40
Intermittent (3x440–480 V) [A]	16.5	21.3	31.5	40.5	51	60
Maximum cable size (Mains, motor) [mm ² /AWG]	4/10			16/6		
Maximum input current						
Continuous (3x380–440 V) [A]	19.2	24.8	33	42	34.7	41.2
Intermittent (3x380–440 V) [A]	27.4	36.3	47.5	60	49	57.6
Continuous (3x440–480 V) [A]	16.6	21.4	29	36	31.5	37.5
Intermittent (3x440–480 V) [A]	23.6	30.1	41	52	44	53
EMC filter type	C2/C4					

7 Ambient Conditions

Protection rating	IP20/Open Type (IP21/Type 1 conversion kit as an option).
Temperature during operation	-20 °C...+55 °C (-4 °F...+131 °F), -10 °C...+50 °C (+14 °F...+131 °F) without derating.

Temperature during storage/transport	-25 °C...+65/+70 °C (-13 °F...+149/+158 °F).	
Relative humidity	5–95%, non-condensing during operation.	
Altitude⁽¹⁾	Without derating: 1000 m (3280 ft). With derating: 1000 m (3280 ft) to 4000 m (13123 ft), derate the output current by 1% for each 100 m (328 ft).	
Contamination level	Storage	IEC 60721-3-1, Class 1C2 (aggressive gases), Class 1S11 (dust/sand).
	Transportation	IEC 60721-3-2, Class 2C2 (aggressive gases), Class 2S5 (dust/sand).
	Operation	IEC 60721-3-3, Class C4 (aggressive gases), Class 3S6 (dust/sand).
Mechanical conditions	Storage	IEC 60721-3-1, Class 1M11.
	Transportation	IEC 60721-3-2, Class 2M4.
	Operation	IEC 60721-3-3, Class 3M11.

1) Regarding IEC 61800-5-1 compliance, the default maximum altitude is 2000 m (6562 ft). When the installation site is at an altitude of 2000 m (6562 ft) to 4000 m (13123 ft), contact Danfoss for further information.

8 EMC Compatibility and Motor Cable Length

- Drive with built-in EMC filter fulfills radiated emission C2 limits.
- Drive with non built-in EMC filter fulfills conducted/radiated emission C4 requirements.
- The drive is designed to operate with optimum performance within the maximum motor cable lengths defined in [Table 11](#).

Table 10: EMC Compatibility Motor Cable Length

Drive with built-in EMC filter	Maximum motor cable length (shielded), @4kHz	
	C1 (Conducted)	C2 (Conducted)
1x200–240 V	5 m (16.4 ft)	–
3x400–480 V	–	15 m (49.2 ft)

Table 11: Maximum Motor Cable Length

Maximum motor cable length (shielded)	Maximum motor cable length (unshielded)
50 m (164 ft)	75 m (246 ft)

9 Fuses and Circuit Breakers

Table 12: Fuses and Circuit Breakers

iC2-Micro	Non cabinet				Intalled in cabinet				
	UL fuses				CE fuses	UL circuit breaker	CE circuit breaker	Test cabinet size [Height x Width x Depth] [mm (in)]	Minimum cabinet volume [L]
kW (hp)	RK1	T	J	CC	gG	ABB MS165 Maximum trip level	Eaton Max-imum trip level		
Minimum SCCR	5 kA	5 kA			1 kA/3 kA ⁽¹⁾	5 kA	1 kA/3 kA ⁽¹⁾		
Maximum SCCR	–	100 kA			5 kA	65 kA ⁽²⁾	5 kA		
1x100-120 V AC									
0.37 (0.5)	25 A				25 A	25 A	PKZM4-25	500 x 400 x 260 (19.7 x 15.7 x 10.2)	52
1.1 (1.5)	35 A				50 A	42 A	PKZM4-50		
1x200-240 V AC									
0.37–0.75 (0.5–1.0)	25 A				25 A	25 A	PKZM4-25	500 x 400 x 260 (19.7 x 15.7 x 10.2)	52
1.5 (2.0)	35 A				35 A	32 A	PKZM4-32		
2.2 (3.0)	40 A				50 A	42 A	PKZM4-50		
3x200-240 V AC									
0.37–0.75 (0.5–1.0)	15 A				16 A	16 A	PKZM0-16	500 x 400 x 260 (19.7 x 15.7 x 10.2)	52
1.5 (2.0)	30 A				32 A	32 A	PKZM4-32		
2.2–3.7 (3.0–5.0)	40 A				40 A	42 A	PKZM4-40		
5.5–7.5 (7.5–10)	60 A				63 A	65 A	PKZM4-63	800 x 400 x 300 (31.5 x 15.7 x 11.8)	96
11 (15)	60 A				63 A (80 A ⁽³⁾)	80 A	NZMN1-A80		
3x380-480 V									
0.37–1.5 (0.5–2.0)	15 A				16 A	16 A	PKZM0-16	500 x 400 x 260 (19.7 x 15.7 x 10.2)	52
2.2–4.0 (3.0–5.5)	30 A				32 A	32 A	PKZM4-32		
5.5–7.5 (7.5–10)	40 A				40 A	42 A	PKZM4-40		
11–15 (15–20)	60 A				63 A	65 A	PKZM4-63	800 x 400 x 300 (31.5 x 15.7 x 11.8)	96
18.5–22 (25–30)	60 A				63 A (80 A ⁽³⁾)	80 A	NZMN1-A80		

1) The rating is 1 kA for a maximum continuous input current of up to 16 A, and 3 kA for a maximum continuous input current above 16 A.
2) The power ratings of the drive up to 15 kW (20 hp) are 65 kA when protected by Type E CMC, 18.5 kW (25 hp) and 22 kW (30 hp) are 50 kA when protected by Type E CMC.
3) When using an 80 A fuse, the drive must be installed in a cabinet.

10 Technical Documentation

Scan the QR code to access more technical documents for the drive. Or, after scanning the QR code, click **Global English** on the website to select your local region's website, search **iC2-Micro Frequency Converters** to find the documents in your own languages.

Danfoss A/S

Ulsnaes 1, DK-6300 Graasten

drives.danfoss.com



Any information, including, but not limited to information on selection of product, its application or use, product design, weight, dimensions, capacity or any other technical data in product manuals, catalog descriptions, advertisements, etc. and whether made available in writing, orally, electronically, online or via download, shall be considered informative, and is only binding if and to the extent, explicit reference is made in a quotation or order confirmation. Danfoss cannot accept any responsibility for possible errors in catalogs, brochures, videos and other material. Danfoss reserves the right to alter its products without notice. This also applies to products ordered but not delivered provided that such alterations can be made without changes to form, fit or function of the product. All trademarks in this material are property of Danfoss A/S or Danfoss group companies. Danfoss and the Danfoss logo are trademarks of Danfoss A/S. All rights reserved.