

SH

# Shuttle Valves



*Danfoss*

# Shuttle Valves

## Application Notes

### Basic Operation: Load Shuttle Valve

Load shuttle valves sense the higher pressure between two lines and allow a signal to the third port, while blocking the lower pressure port. The valve will sense the pressure difference between port 1 and 3 with the higher pressure referenced to port 2.

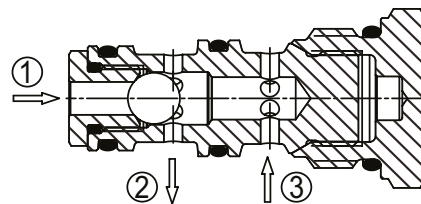
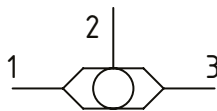

### Load Shuttle Valve Types

In addition to cartridge type load shuttle valves, insert and line mounted versions are also available. The insert can be mounted deep within the manifold using the space available efficiently. A line mounted valve can be mounted in the piping when a multi function HIC is not required will sense the pressure difference between port 1 and 3 with the higher pressure referenced to port 2.

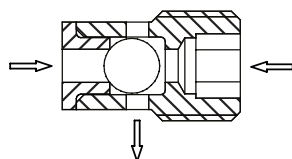

▲ Inserted

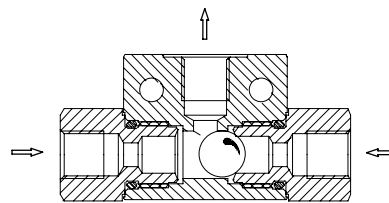

▲ Line Mounted

### Typical Applications

In addition to cartridge type load shuttle valves, insert and line mounted versions are also available. The insert can be mounted deep within the

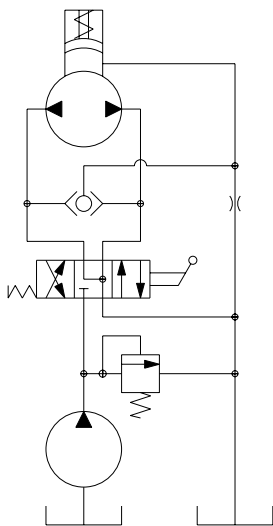

▲ Brake release

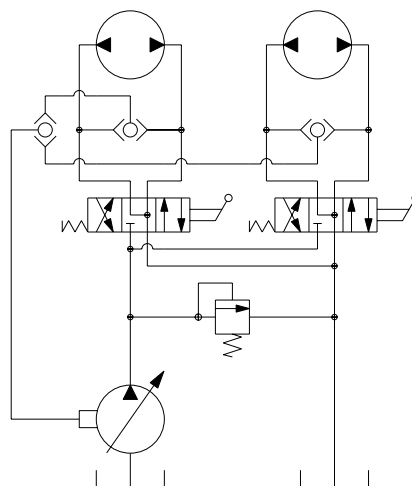

▲ Load Sense

Classified as Business

# Shuttle Valves

## Application Notes

### Basic Operation: Hot Oil Shuttle Valves

Hot oil shuttle valves are spool type valves that are internally piloted sensing two pressures and opening the lower pressure port to the outlet while blocking the higher-pressure port. The name is derived from its position in closed loop hydrostatic circuits where the hot oil from the motor outlet is diverted through a cooler. The exhaust flow can be regulated by balancing a purge relief valve setting, normally fitted to port 3 with the charge pump relief pressure. A closed center condition is used where it is important that flow is not lost across the two legs of the Hydrostatic circuit which could potentially delay or make unstable the initial movement of the machine. An open centre condition may be used where pressure spikes across the Hydrostatic circuit need to be avoided especially during rapid reversal.

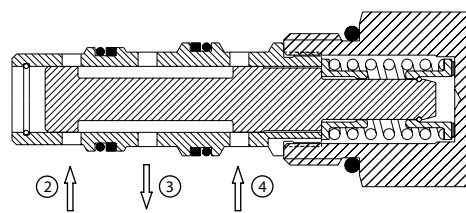
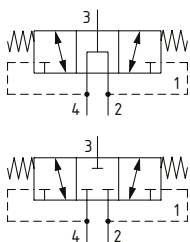

### Typical Applications

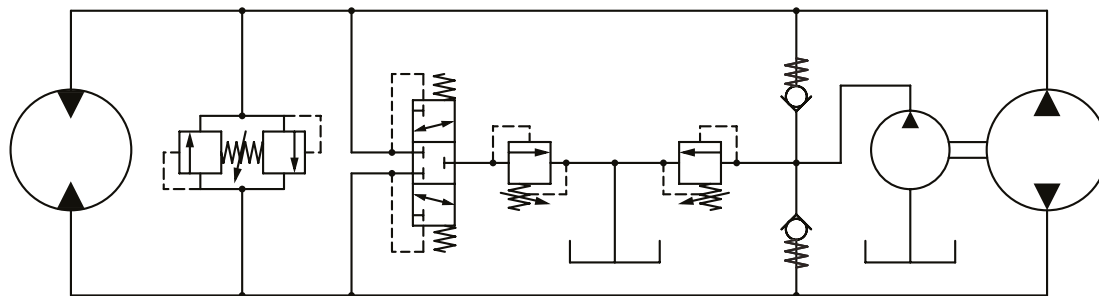

Closed loop Hydrostatic transmission flushing circuit.

# Shuttle Valves

## Quick reference

Shuttle Valves	Model No.	Cavity	Description	Flow*	Pressure	Page
	<a href="#">CP124-1</a>	<b>CP04-3</b>	Load Shuttle Valve	3.7 l/min [1 US gpm]	350 bar [5000 psi]	<b>5</b>
	<a href="#">SV 04</a>	<b>NCS04/3</b>	Load Shuttle Valve	15 l/min [4 US gpm]	315 bar [4600 psi]	<b>6</b>
	<a href="#">CP128-1</a>	<b>SDC08-3</b>	Load Shuttle Valve	22 l/min [5.8 US gpm]	315 bar [4600 psi]	<b>7</b>
	<a href="#">CP120-4</a>	<b>SDC10-3</b>	Load Shuttle Valve	25 l/min [7 US gpm]	330 bar [4800 psi]	<b>8</b>
	<a href="#">SV 06</a>	<b>NCS06/3</b>	Load Shuttle Valve	48 l/min [12.7 US gpm]	350 bar [5000 psi]	<b>9</b>
	<a href="#">1SH10</a>	<b>A16927</b>	Load Shuttle Valve, Insert type	20 l/min [5 US gpm]	350 bar [5000 psi]	<b>10</b>
In-line Shuttle Valves	Model No.	Cavity	Description	Flow*	Pressure	Page
	<a href="#">VS 06</a>	<b>N/A</b>	Load Shuttle Valve, Line Mounted, 1/4 BSP	35 l/min [9 US gpm]	210 bar [3000 psi]	<b>11</b>
	<a href="#">VS 10</a>	<b>N/A</b>	Load Shuttle Valve, Line Mounted, 3/8 BSP	45 l/min [12 US gpm]	210 bar [3000 psi]	<b>12</b>
Shuttle Valves	Model No.	Cavity	Description	Flow	Pressure	Page
	<a href="#">SH08-R</a>	<b>SDC08-4</b>	Load Shuttle Valve, Reverse Direction	5 l/min [1.3 US gpm]	230 bar [3300 psi]	<b>13</b>
Hot Oil Shuttle Valves	Model No.	Cavity	Description	Flow*	Pressure	Page
	<a href="#">CP720-3</a>	<b>SDC10-4</b>	Hot Oil Shuttle Valve	25 l/min [7 US gpm]	350 bar [5000 psi]	<b>14</b>
	<a href="#">CP721-3</a>	<b>CP12-3M</b>	Hot Oil Shuttle Valve	90 l/min [24 US gpm]	350 bar [5000 psi]	<b>15</b>
	<a href="#">HS12</a>	<b>CP12-3M</b>	Hot Oil Shuttle Valve	80 l/min [21 US gpm]	450 bar [6500 psi]	<b>16</b>

\*Flow ratings are for reference only. Refer to individual product page for performance information.

## Shuttle Valves

### CP124-1

Load Shuttle Valve

350 bar [5000 psi] • 3.7 l/min [1 US gpm]

#### DESCRIPTION AND OPERATION

This valve senses the higher of the two input pressures at ports 1 and 3 and routes it to the output port 2.

#### SCHEMATIC

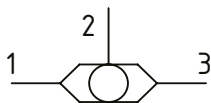

#### DIMENSIONS

mm [in]

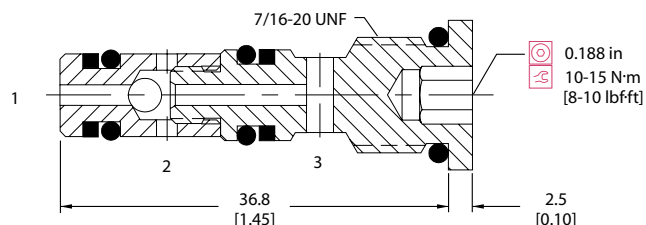

#### PERFORMANCE DATA

Rated pressure*	350 bar [5000 psi]
Rated flow at 7 bar [100psi]	3.7 l/min [1 US gpm]
Leakage	6 drops/min @ Rated pressure
Weight	0.02 kg [0.04 lb]
Cavity	CP04-3

\*Rated pressure based on NFPA fatigue test standard [at 1 million cycles]

#### PERFORMANCE CURVES

##### Pressure drop

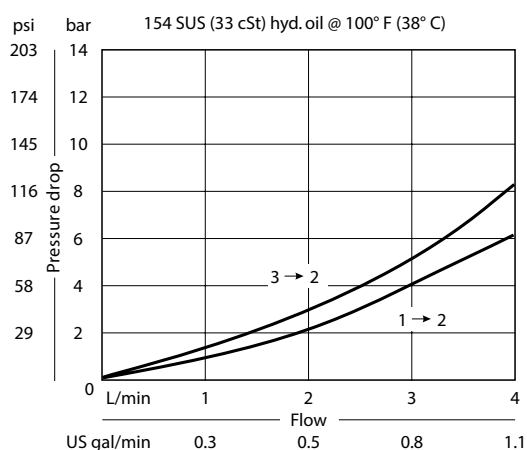

#### MODEL CODE

CP124 - 1 - B - 4S

##### Seal Option

Code	Seal kit
B-Buna-N	120111
V-Viton	120282

##### Housing

Code	Ports & Material	Housing Model Code
0	No Housing	No Housing
2B	Al, 1/4 BSP	CP04-3-2B
4S	Al, #4 SAE	CP04-3-4S

\* Aluminum bodies are to be used for pressures less than 210 bar [3000 psi].

\* Additional housings available

## Shuttle Valves

### SV 04

Load Shuttle Valve

315 bar [4600 psi] • 15 l/min [4 US gpm]

#### DESCRIPTION AND OPERATION

This valve senses the higher of the two input pressures at ports 1 and 3 and routes it to the output port 2.

#### SCHEMATIC

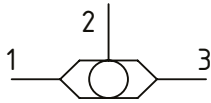

#### DIMENSIONS

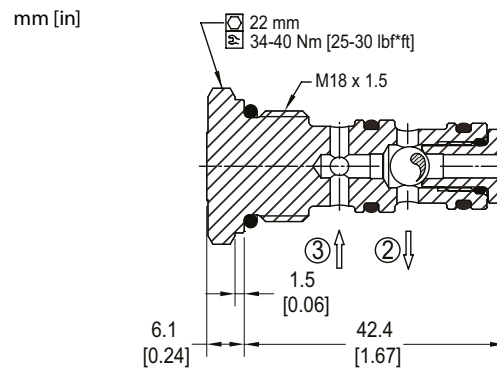

#### PERFORMANCE DATA

<b>Rated pressure*</b>	<b>315 bar [4600 psi]</b>
<b>Rated flow at 7 bar [100psi]</b>	<b>15 l/min [4 US gpm]</b>
Leakage	6 drops/min @ Rated pressure
Weight	0.07 kg [0.15 lb]
Cavity	NCS04/3

\*Rated pressure based on NFPA fatigue test standard [at 1 million cycles]

#### PERFORMANCE CURVES

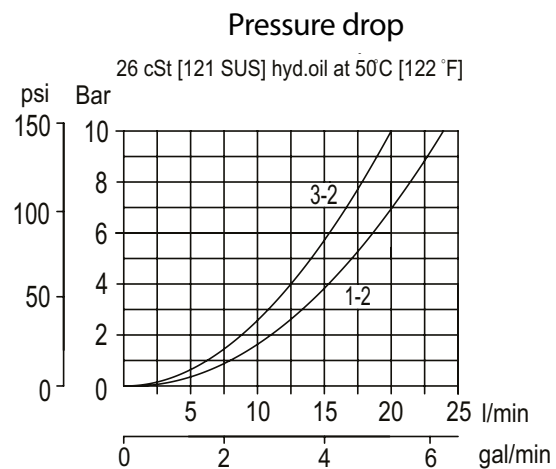

#### MODEL CODE

**SV04 - 00 - V**

##### Housing

Code	Ports & Material	Housing Model Code
00	No Housing	No Housing
SE1/4	AL, 1/4 BSP	NCS04/3-SE-1/4
SE45	AL, #4 SAE	NCS04/3-SE-45
SE65	AL, #6 SAE	NCS04/3-SE-65

\* Aluminum bodies are to be used for pressures less than 210 bar [3000 psi].

\* Additional housings available

##### Seal Option

Code	Seal kit
B-Omit	230000160
V-Viton	230000450

## Shuttle Valves

### CP128-1

Load Shuttle Valve

315 bar [4600 psi] • 22 l/min [5.8 US gpm]

#### DESCRIPTION AND OPERATION

This valve senses the higher of the two input pressures at ports 1 and 3 and routes it to the output port 2.

#### SCHEMATIC

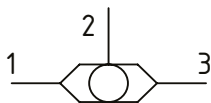

#### DIMENSIONS

mm [in]

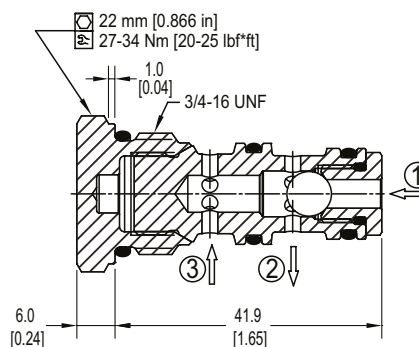

#### PERFORMANCE DATA

Rated pressure*	315 bar [4600 psi]
Rated flow at 7 bar [100psi]	22 l/min [5.8 US gpm]
Leakage	6 drops/min @ Rated pressure
Weight	0.06 kg [0.14 lb]
Cavity	SDC08-3

\*Rated pressure based on NFPA fatigue test standard [at 1 million cycles]

#### PERFORMANCE CURVES

##### Pressure drop

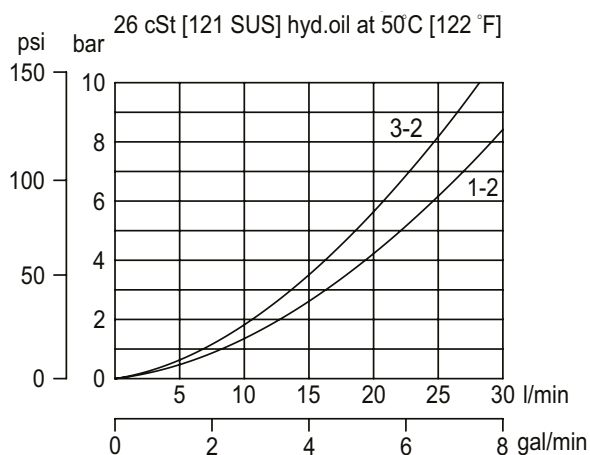

#### MODEL CODE

CP128 - 1 - B - 0

##### Seal Option

Code	Seal kit
B-Buna-N	120238
V-Viton	120239

##### Housing

Code	Ports & Material	Housing Model Code
0	No Housing	No Housing
SE2B	AL, 1/4 BSP	SDC08-3-SE-2B
SE3B	AL, 3/8 BSP	SDC08-3-SE-3B
4S	AL, #4 SAE	CP08-3-4S
6S	AL, #6 SAE	CP08-3-6S

\* Aluminum bodies are to be used for pressures less than 210 bar [3000 psi].

\* Additional housings available

## Shuttle Valves

### CP120-4

Load Shuttle Valve

330 bar [4800 psi] • 25 l/min [7 US gpm]

#### DESCRIPTION AND OPERATION

This valve senses the higher of two input pressures at 1 and 3, and routes it to the output 2.

#### SCHEMATICS

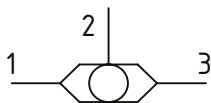

#### DIMENSIONS

mm [in]

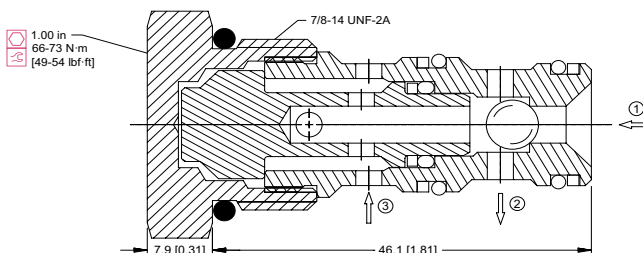

#### PERFORMANCE DATA

Rated pressure*	330 bar [4800 psi]
Rated flow at 7 bar [100psi]	25 l/min [7 US gpm]
Leakage	6 drops/min @ Rated pressure
Weight	0.10 kg [0.22 lb]
Cavity	SDC10-3

\*Rated pressure based on NFPA fatigue test standard [at 1 million cycles]

#### PERFORMANCE CURVES

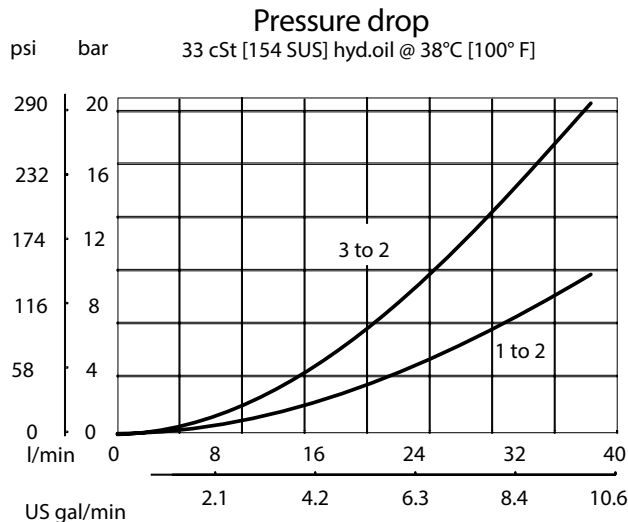

#### MODEL CODE

CP120 - 4 - B - 8S

##### Seal Option

Code	Seal kit
B-Buna-N	120027
V-Viton	120028

##### Housing

Code	Ports & Material	Housing Model Code
0	No Housing	No Housing
SE3B	Al, 3/8 BSP	SDC10-3-SE-3B
SE4B	Al, 1/2 BSP	SDC10-3-SE-4B
6S	Al, #6 SAE	CP10-3-6S
8S	Al, #8 SAE	CP10-3-8S
S6S	Ductile, #6 SAE	CP10-3-S6S
S8S	Ductile, #8 SAE	CP10-3-S8S

\* Aluminum bodies are to be used for pressures less than 210 bar [3000 psi].

\* Additional housings available

## Shuttle Valves

### SV 06

Load Shuttle Valve

350 bar [5000 psi] • 48 l/min [12.7 US gpm]

#### DESCRIPTION AND OPERATION

This valve senses the higher of two input pressures at 1 and 3, and routes it to the output 2.

#### SCHEMATIC

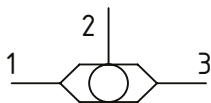

#### DIMENSIONS

mm [in]

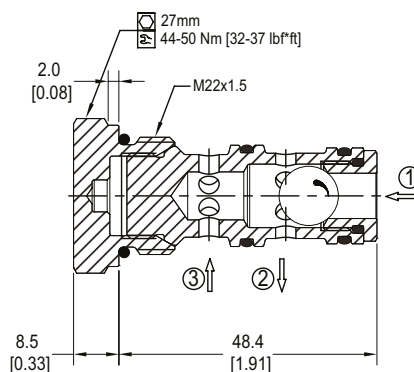

#### PERFORMANCE DATA

Rated pressure*	350 bar [5000 psi]
Rated flow at 7 bar [100psi]	48 l/min [12.7 US gpm]
Leakage	6 drops/min @ Rated pressure
Weight	0.11 kg [0.24 lb]
Cavity	NCS06/3

\*Rated pressure based on NFPA fatigue test standard [at 1 million cycles]

#### PERFORMANCE CURVES

##### Pressure drop

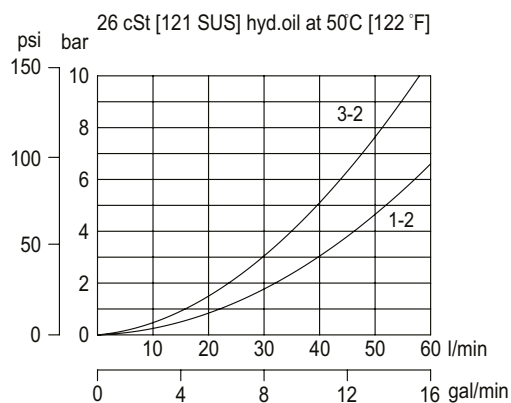

#### MODEL CODE

SV06 - 00 - V

##### Housing

Code	Ports & Material	Housing Model Code
00	No Housing	No Housing
SE3/8	AL, 3/8 BSP	NCS06/3-SE3/8
SE1/2	AL, 1/2 BSP	NCS06/3-SE1/2
SE6S	AL, #6 SAE	NCS06/3-SE-6S
SE8S	AL, #8 SAE	NCS06/3-SE-8S

\* Aluminum bodies are to be used for pressures less than 210 bar [3000 psi].

\* Additional housings available

##### Seal Option

Code Seal kit

B-Omit 230000070

V-Viton 230000110

## Shuttle Valves

### 1SH10

Load Shuttle Valve, Insert type  
350 bar [5000 psi] • 20 l/min [5 US gpm]

#### DESCRIPTION AND OPERATION

This valve senses the higher of two input pressures at 1 and 3, and routes it to output 2.

#### SCHEMATIC

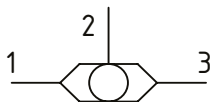

#### DIMENSIONS

mm [in]

Using LOC-TITE 542, torque cartridge to 8-10 Nm against the bottom of the cavity.

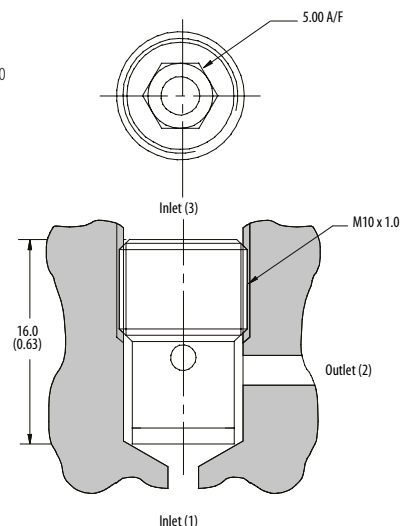

#### PERFORMANCE DATA

<b>Rated pressure</b>	<b>350 bar [5000 psi]</b>
<b>Rated flow</b>	<b>20 l/min [5 US gpm]</b>
<b>Leakage</b>	0.6 ml/min max
<b>Weight</b>	0.05 kg [0.11 lbs]
<b>Cavity</b>	A16927

#### PERFORMANCE CURVES

##### Pressure drop

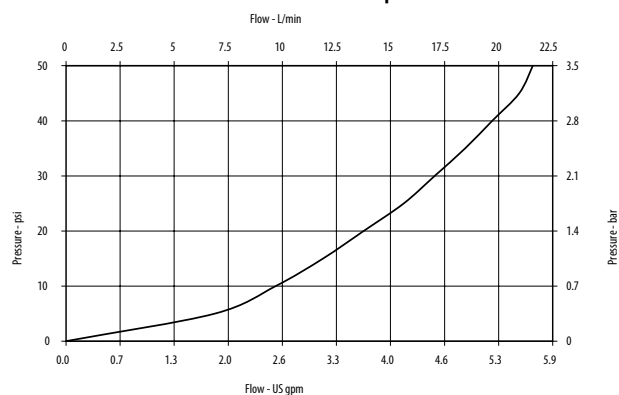

#### MODEL CODE

**1SH10**

**Basic code**

1SH10-Cartridge Only

## Shuttle Valves

### VS 06

Load Shuttle Valve, Line Mounted, 1/4 BSP  
**210 bar [3000 psi] • 35 l/min [9 US gpm]**

#### DESCRIPTION AND OPERATION

This valve senses the higher of the two input pressures and routes it to the output port.

#### SCHEMATIC

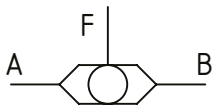

#### DIMENSIONS

mm [in]

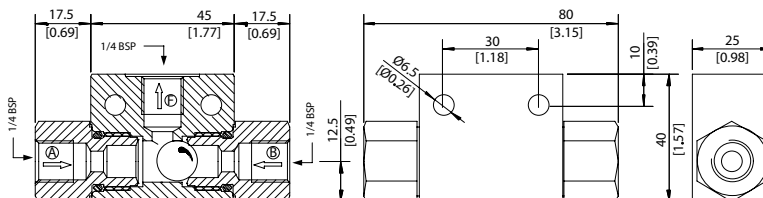

#### PERFORMANCE DATA

<b>Rated pressure</b>	<b>210 bar [3000 psi]</b>
<b>Rated flow at 7 bar [100psi]</b>	<b>35 l/min [9 US gpm]</b>
Leakage	6 drops/min @ Rated pressure
Weight	0.22 kg [0.49 lb]

#### PERFORMANCE CURVES

##### Pressure drop

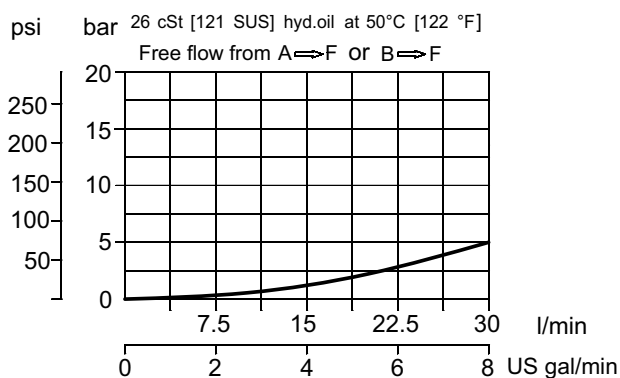

#### MODEL CODE

**VS06 - G - V**

**Seal Option**  
 Omit-Buna-N  
 V-Viton

## Shuttle Valves

### VS 10

Load Shuttle Valve, Line Mounted, 3/8 BSP  
**210 bar [3000 psi] • 45 l/min [12 US gpm]**

#### DESCRIPTION AND OPERATION

This valve senses the higher of two input pressures and routes it to the output port.

#### SCHEMATIC

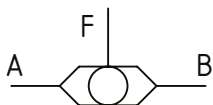

#### DIMENSIONS

mm [in]

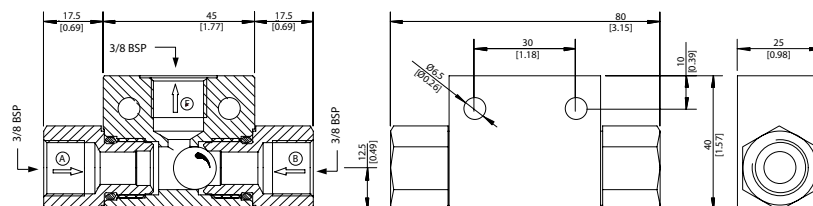

#### PERFORMANCE DATA

<b>Rated pressure</b>	<b>210 bar [3000 psi]</b>
<b>Rated flow at 7 bar [100psi]</b>	<b>45 l/min [12 US gpm]</b>
<b>Leakage</b>	6 drops/min @ Rated pressure
<b>Weight</b>	0.19 kg [0.42 lb]

#### PERFORMANCE CURVES

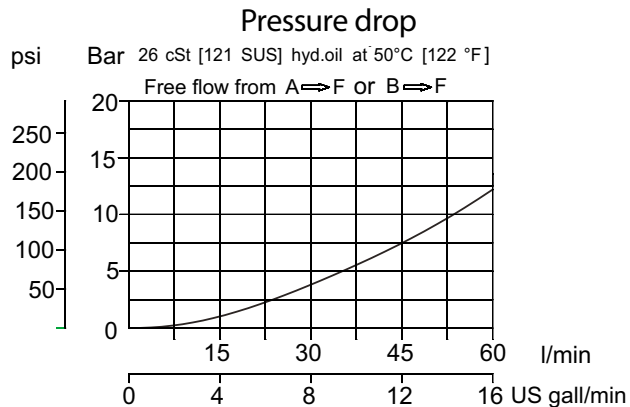

#### MODEL CODE

**VS 10 - G - V**

**Seal Option**  
 Omit-Buna-N  
 V-Viton

## Shuttle Valves

### SH08-R

Load Shuttle Valve, Reverse Direction  
**230 bar [3300 psi] • 5 l/min [1.3 US gpm]**

#### DESCRIPTION AND OPERATION

This valve senses the lower of two input pressures at ports 2 and 4 and routes it to the output at port 3.

#### SCHEMATIC

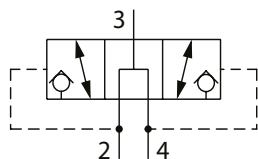

#### DIMENSIONS

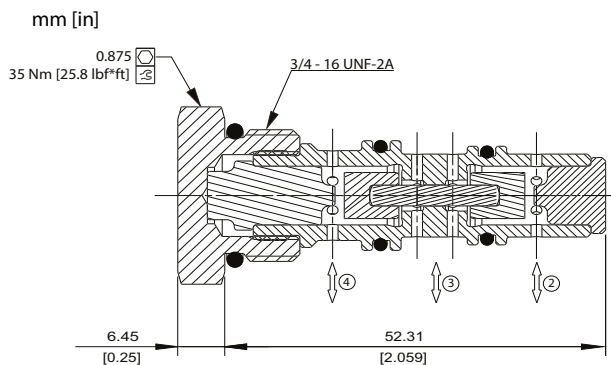

#### PERFORMANCE DATA

<b>Rated pressure</b>	<b>230 bar [3300 psi]</b>
<b>Rated flow at 7 bar [100psi]</b>	<b>5 l/min [1.3 US gpm]</b>
Leakage	6 drops/min @ Rated pressure
Weight	0.2 kg [0.44 lb]
Cavity	SDC08-4

\*Rated pressure based on NFPA fatigue test standard [at 1 million cycles]

#### PERFORMANCE CURVES

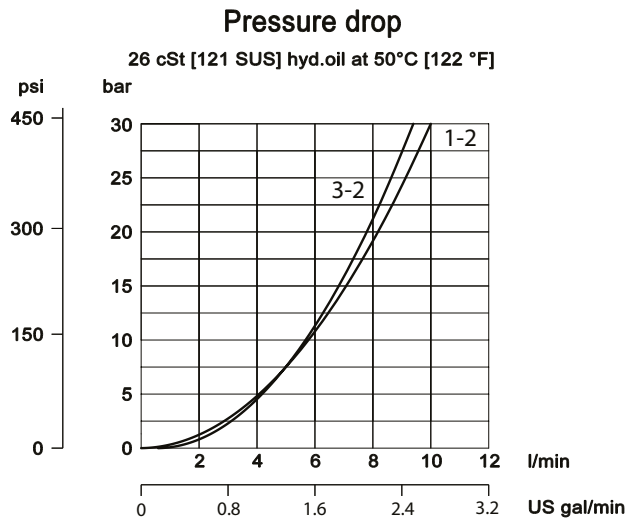

#### MODEL CODE

**SH08 - R - B - 4S**

##### Seal Option

Code	Seal kit
Omit-Buna-N	11362953
V-Viton	11362954

##### Housing

Code	Ports & Material	Housing Model Code
00	No Housing	
4S	#4 SAE, AL	CP08-4-4S
L2B	1/4 BSP, AL	SDC08-4-L2B

\* Aluminum bodies are to be used for pressures less than 210 bar [3000 psi].

\* Additional housings available

## Shuttle Valves

### CP720-3

Hot Oil Shuttle Valve

350 bar [5000 psi] • 25 l/min [7 US gpm]

#### DESCRIPTION AND OPERATION

This valve has an internally piloted spool that directs flow from the lower pressure inlet, 2 or 4, to the output at 3.

#### SCHEMATIC

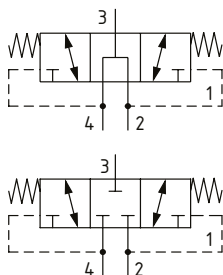

#### DIMENSIONS

mm [in]

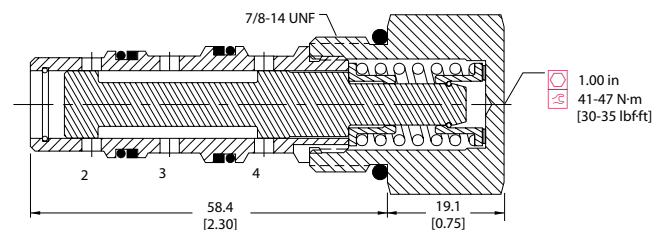

#### PERFORMANCE DATA

<b>Rated pressure</b>	<b>350 bar [5000 psi]</b>
<b>Rated flow at 7 bar [100psi]</b>	<b>25 l/min [7 US gpm]</b>
Leakage	82 cm <sup>3</sup> /min [5 in <sup>3</sup> /min] @ 207 bar [3000 psi]
Weight	0.15 kg [0.34 lb]
Cavity	SDC10-4

#### PERFORMANCE CURVES

##### Pressure drop

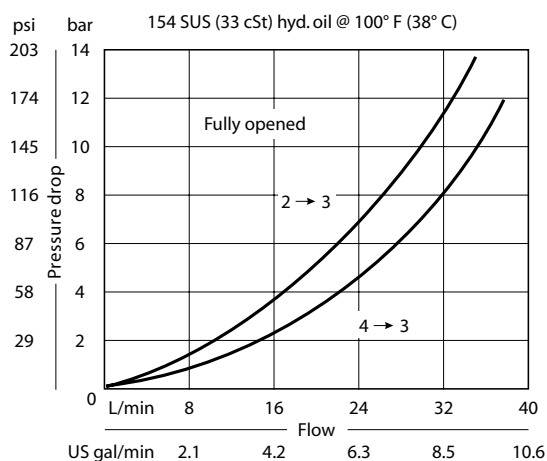

#### MODEL CODE

**CP720 - 3 - B - 8S - 080 - C**

##### Seal Option

Code	Seal kit
<b>B</b> -Buna-N	11032943
<b>V</b> -Viton	11032944

##### Housing

Code	Ports & Material	Housing Model Code
<b>0</b>	No Housing	No Housing
<b>L3B</b>	Al, 3/8 BSP	SDC10-4-L-3B
<b>L4B</b>	Al, 1/2 BSP	SDC10-4-L-4B
<b>6S</b>	Al, #6 SAE	CP10-4-6S-X1
<b>8S</b>	Al, #8 SAE	CP10-4-8S-X1
<b>S6S</b>	Ductile, #6 SAE	CP10-4-S6S
<b>S8S</b>	Ductile, #8 SAE	CP10-4-S8S

\* Aluminum bodies are to be used for pressures less than 210 bar [3000 psi].

\* Additional housings available

##### Spool Configuration

**0**-Open  
**C**-Closed

##### Shift Pressure

Code	Bar	Psi
<b>050</b>	3.4	[50]
<b>080</b>	5.5	[80]

## Shuttle Valves

### CP721-3

Hot Oil Shuttle Valve

350 bar [5000 psi] • 90 l/min [24 US gpm]

#### DESCRIPTION AND OPERATION

This valve has an internally piloted spool that directs flow from the lower pressure inlet, 1 or 3, to the output at 2.

#### SCHEMATIC

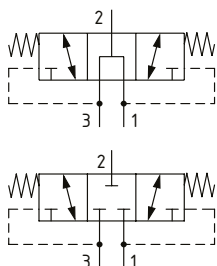

#### DIMENSIONS

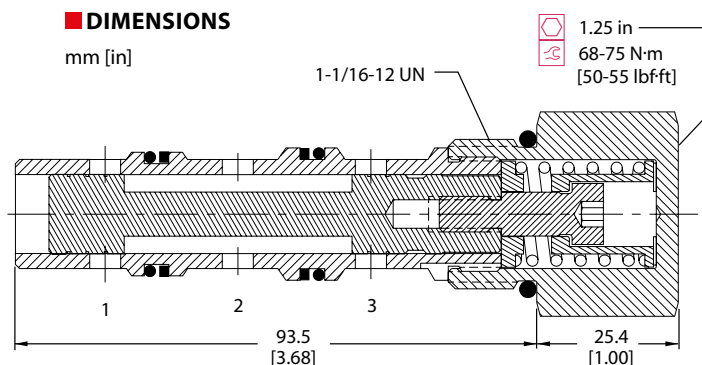

#### PERFORMANCE DATA

Rated pressure*	350 bar [5000 psi]
Rated flow at 7 bar [100psi]	90 l/min [24 US gpm]
Leakage	82 cm <sup>3</sup> /min [5 in <sup>3</sup> /min] @ 207 bar [3000 psi]
Weight	0.34 kg [0.75 lb]
Cavity	CP12-3M

\*Rated pressure based on NFPA fatigue test standard [at 1 million cycles]

#### PERFORMANCE CURVES

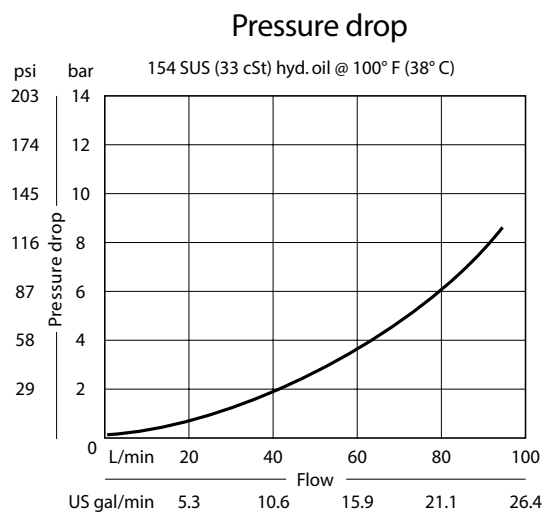

#### MODEL CODE

CP721 - 3 - B - 125 - 100 - C

##### Seal Option

Code	Seal kit
B	Buna-N 120098
V	Viton 120099

##### Housing

Code	Ports & Material	Housing Model Code
0	No Housing	No Housing
6B	AL, 3/4 BSP	CP12-3M-6B
10S	AL, #10 SAE	CP12-3M-10S
12S	AL, #12 SAE	CP12-3M-12S
S12S	Ductile, #12 SAE	CP12-3M-S12S

\* Aluminum bodies are to be used for pressures less than 210 bar [3000 psi].

\* Additional housings available

##### Spool Configuration

0-Open  
C-Closed

##### Shift Pressure

Code	Bar	Psi
025	1.6	[25]
050	3.4	[50]
100	6.9	[100]

# Shuttle Valves

## HS12

Hot Oil Shuttle Valve

450 bar [6500 psi] • 80 l/min [21 US gpm]

### DESCRIPTION AND OPERATION

This valve has an internally piloted spool that directs flow from the lower pressure inlet, 1 or 3, to the output at 2.

### SCHEMATIC

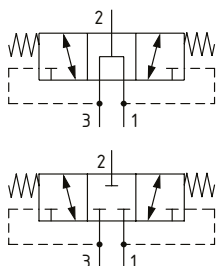

### DIMENSIONS

mm [in]

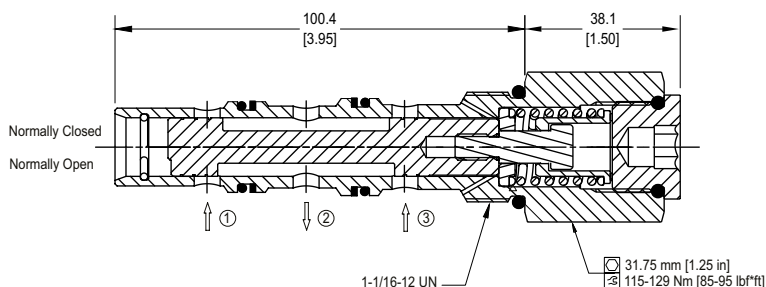

### PERFORMANCE DATA

Rated pressure*	450 bar [6500 psi]
Rated flow at 7 bar [100psi]	80 l/min [21 US gpm]
Leakage	82 cm <sup>3</sup> /min [5 in <sup>3</sup> /min] @ 207 bar [3000 psi]
Weight	0.41 kg [0.90 lb]
Cavity	CP12-3M

\* Rated Pressure based on NFPA fatigue test standards [at 1 Million Cycles, 90% assurance, 90% verification]

### PERFORMANCE CURVES

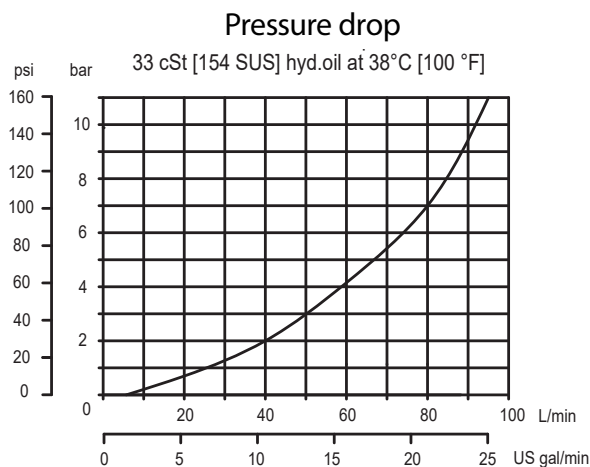

### MODEL CODE

HS12 - NC - 100 - U - 00

#### Spool Configuration

NO-Normally Open  
N-Normally Closed

#### Shift Pressure

Code	Bar	Psi
025	1.6	[25]
050	3.4	[50]
100	6.9	[100]

#### Housing

Code	Ports & Material	Housing Model Code
00	No Housing	No Housing
S12S	STEEL, #12 SAE	CP12-3M-S12S

\* Aluminum bodies are to be used for pressures less than 210 bar [3000 psi].

\* Additional housings available

#### Seal Option

Code	Seal kit
U-Urethane	11251458
V-Viton	120099

*Danfoss*