

MC

Motion Control Valves



Danfoss

Motion Control Valves

Application Notes

Basic Operation Motion Control Valves

Motion control valves, often called counterbalance or overcenter valves, are pilot assisted relief valves with an integral bypass check. These simple devices are used to stop a load from running away from a pump, hold a load in position, and when mounted onto, or into an actuator, provide load safety in the event of a hose failure. The valve is made up of a direct acting or differential area type relief valve and a separate pilot area or a pilot piston. Pressure on this area is used to open the valve in normal operation. The poppet will sit on a spring-loaded seat to provide a free flow function from the valve port to the cylinder port. The relief valve function should be set at 1.3 times the maximum load induced pressure to make sure the load is held in the case of a hose failure. The pilot area is larger than the relief pressure area by a factor called the pilot ratio. Variations in pilot pressure during normal operation will cause the valve to meter the flow between the cylinder port and the valve port.

Pilot pressure to open the valve - $\frac{\text{Relief setting} - \text{induced load pressure}}{\text{Pilot ratio}}$

Depending on the design of the valve, back pressure in the valve port can affect the relief pressure and the pilot pressure required to keep the valve open. The relief function is normally used for thermal pressure or shock protection. Care should be taken if the relief valve is required to take full flow.

There are various designs available, each covering a different set of applications.

Standard Direct Acting Poppet

The check section allows free flow into the actuator from port 2 to port 1, and then holds and locks the load against movement. The pilot assisted relief valve section will give controlled movement from port 1 to 2 when pilot pressure is applied at port 3. The direct acting relief section is normally set to open at a pressure at least 1.3 times the maximum load induced pressure. The pilot pressure required to open the valve and allow movement depends on the pilot ratio of the valve. For optimization of load control and energy usage, a choice of pilot ratios is available. The spring chamber is connected to the valve port 2, so any back pressure will affect the relief pressure by a factor of the pilot ratio plus 1. The pilot pressure required will also be increased on a 1:1 basis.

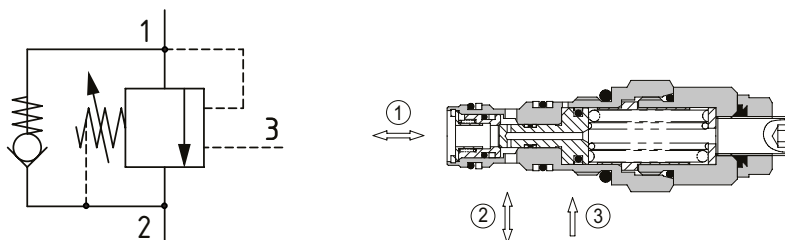

Standard Differential Area Poppet Port 1 Pilot

The check section allows free flow into the actuator from port 2 to port 3, and then holds and locks the load against movement. The pilot assisted relief valve section will give controlled movement from port 3 to 2 when pilot pressure is applied at port 1. The direct acting relief section is normally set to open at a pressure at least 1.3 times the maximum load induced pressure. The pilot pressure required to open the valve and allow movement depends on the pilot ratio of the valve. For optimization of load control and energy usage, a choice of pilot ratios is available. The spring chamber is connected to the valve port 2, so any back pressure will affect the relief pressure by a factor of the pilot ratio plus 1. The pilot pressure required will also be increased on a 1:1 basis.

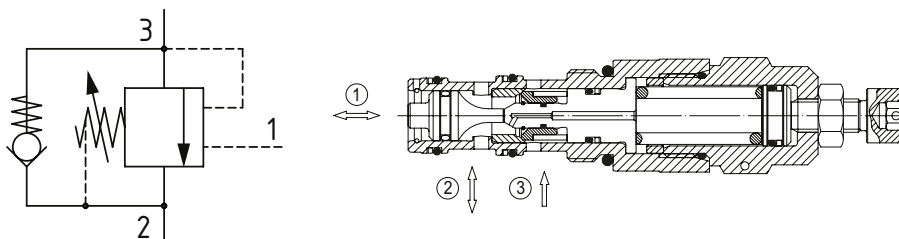

Motion Control Valves

Application Notes

Differential Area Poppet

The check section allows free flow into the actuator from port 2 to port 1, and then holds and locks the load against movement. The pilot assisted relief valve section will give controlled movement from port 1 to 2 when pilot pressure is applied at port 3. The differential area relief section is normally set to open at a pressure at least 1.3 times the maximum load induced pressure. The pilot pressure required to open the valve and allow movement depends on the pilot ratio of the valve. For optimization of load control and energy usage, a choice of pilot ratios is available. The spring chamber is connected to the valve port 2, so any back pressure will affect the relief pressure by a factor of the pilot ratio plus 1. The pilot pressure required will also be increased on a 1:1 basis.

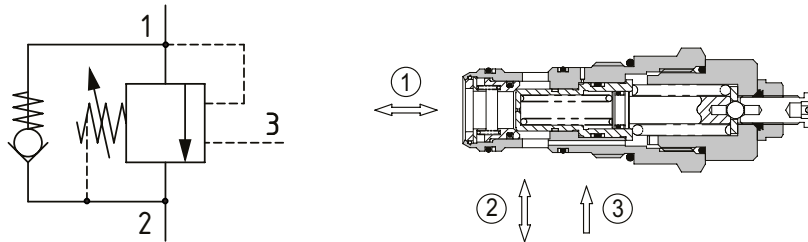

Part Balanced Direct Acting Poppet

The check section allows free flow into the actuator from port 2 to port 1, and then holds and locks the load against movement. The pilot assisted relief valve section will give controlled movement from port 1 to 2 when pilot pressure is applied at port 3. The direct acting relief section is normally set to open at a pressure at least 1.3 times the maximum load induced pressure. The pilot pressure required to open the valve and allow movement depends on the pilot ratio of the valve. For optimization of load control and energy usage, a choice of pilot ratios is available. The spring chamber is connected to the valve port 2, so any back pressure will increase the pilot pressure required on a 1 to 1 basis, but due to a balanced poppet design the relief pressure will not increase. This valve is ideal for closed centre directional valves with service line relief valves that are required to open when the actuator is mechanically overloaded.

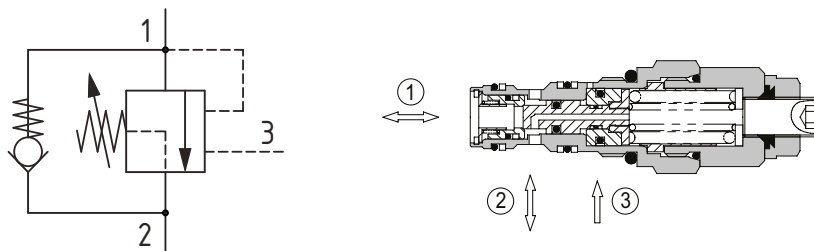

Fully Balanced Direct Acting Poppet

The check section allows free flow into the actuator from port 2 to port 1, and then holds and locks the load against movement. The pilot assisted relief valve section will give controlled movement from port 1 to 2 when pilot pressure is applied at port 3. The direct acting relief section is normally set to open at a pressure at least 1.3 times the maximum load induced pressure. The pilot pressure required to open the valve and allow movement depends on the pilot ratio of the valve. For optimization of load control and energy usage, a choice of pilot ratios is available. The spring chamber is connected to a drain port 4 or to atmosphere, so back pressure will not affect the pilot pressure required or the relief pressure required to open the valve. The valve is ideal for meter out proportional systems where the valve port pressure varies or in the rod side of a cylinder in regenerative circuits. They are available to fit 4 ported cavities, which is preferred, or 3 ported cavities with an atmospheric vent. In this case, leakage from the atmospheric vent port will occur at some stage depending on the condition of oil, the number of cycles or ingress of airborne contamination.

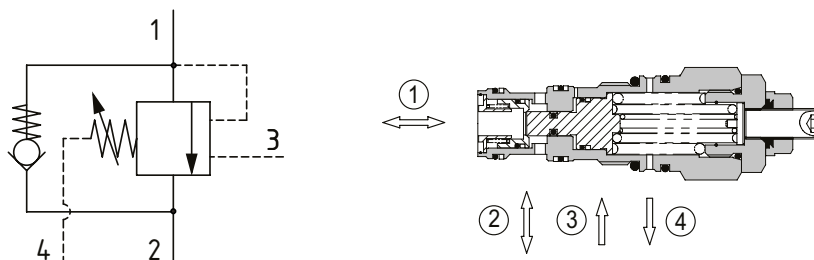

Motion Control Valves

Application Notes

Two Stage Counterbalance Direct Acting Poppet

The check section allows free flow into the actuator from port 2 to port 1, and then holds and locks the load against movement. The pilot assisted relief valve section will give controlled movement from port 1 to 2 when pilot pressure is applied at port 3. The direct acting relief section is normally set to open at a pressure at least 1.3 times the maximum load induced pressure. The pilot pressure required to open the valve and allow movement depends on the pilot ratio of the valve. These valves perform all duties of a standard overcenter valve, but it initially maintains a counterbalance pressure to provide dampening of cylinders when there is a rapid loss in stored pressure. This counterbalance pressure reduces as the pilot pressure increases. Typical applications include extension cylinders on telehandlers, where it is important to have a smooth operation when retracting from full extension. Note: This valve has been designed to eliminate instability from flexible boom applications or where the load induced pressure varies greatly. For optimal results, the settings should be adjusted for each application and then factory set for production quantities. Please contact our Technical Department for more information.

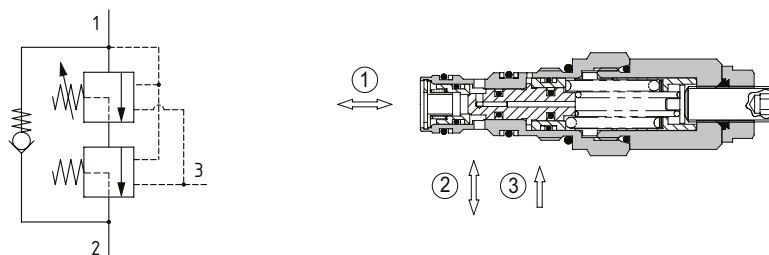

Zero Differential Pilot Operated Metered Poppet

The check section allows free flow into the actuator from port 2 to 1, and then holds and locks the load against movement. The poppet is balanced so that pressure in port 1 will not open the valve. Pilot pressure is applied at port 3 to open the valve, with the flow metered across the angled seat. The valve is used in conjunction with a remote pilot source to provide hose failure protection, load control and load holding functions. If over-pressure or shock pressure protection is required, then a separate relief valve should be used. The drain line allows the valve to be used in corrosive atmospheres preventing the ingestion of airborne contamination.

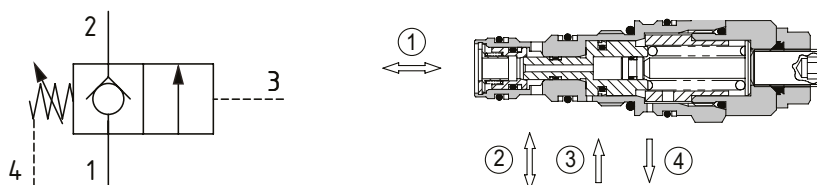

Zero Differential Pilot Operated Metered Bi-Directional Poppet

The poppet is balanced so that pressure in port 1 or 2 will not open the valve. Pilot pressure is applied to port 3 to open the valve with the flow metered across the angled seat. The valve is used in conjunction with a remote pilot source to provide hose failure protection, load control and load holding functions. If over-pressure or shock pressure protection is required, then a separate relief valve should be used. This can be used in many applications where a pressure line needs to be closed at the removal of a pilot pressure.

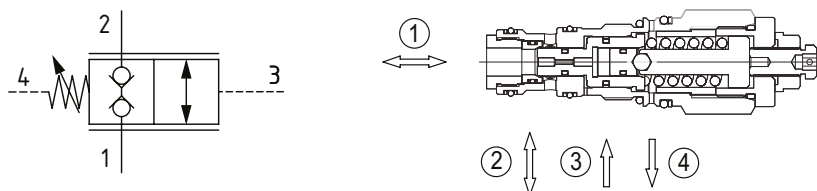

Motion Control Valves

Application Notes

Application Recommendations

- For standard valves, pressure in the valve port adds to the setting of the relief valve by a factor of the (pilot ratio) + 1.
- For standard valves, pressure in the valve port adds to the pilot pressure by a factor of $1 + 1/(\text{pilot ratio})$.
- Standard valves are suitable for most applications and provide excellent stability.
- Direct acting valves are intrinsically more stable than the differential area direct acting product due to the high rate of spring.
- The hysteresis on the direct acting valves is very low.
- The direct acting, high-pressure override on the relief function makes it suitable as a surge relief or a thermal relief but brings extra stability.
- Differential area type valve will offer a lower pressure override when open as a relief valve.
- Part balanced valves remove the need for a vent line to allow the relief valve to remain open if the inlet pressure exceeds the setting.
- For part balanced valves, pilot pressure is increased on a 1:1 ratio when there is back pressure in the valve port.
- The balanced valve with the atmospheric vent will leak eventually to atmosphere. The rate is approximately 1 drop after 40K cycles and more frequently thereafter, depending on the atmosphere and contamination ingress. It is recommended to use the 4 ported valve with the drain port connected separately to tank where possible.
- The counterbalance, two stage valve is ideal for the control of long flexible booms especially if the cylinder bottoms out and a high pressure is trapped. The valve prevents the initial instability and therefore the induced instability.
- The zero differential valves are ideal in a boom lock circuit where the pilot pressure comes from the pilot line to the directional valve. It will provide good control at low speed and minimum pressure drop at high speed.
- Use caution when applying overcenter valves with closed-center directional valves, as the back pressure could cause performance issues. For further information, contact technical support.

Typical Applications

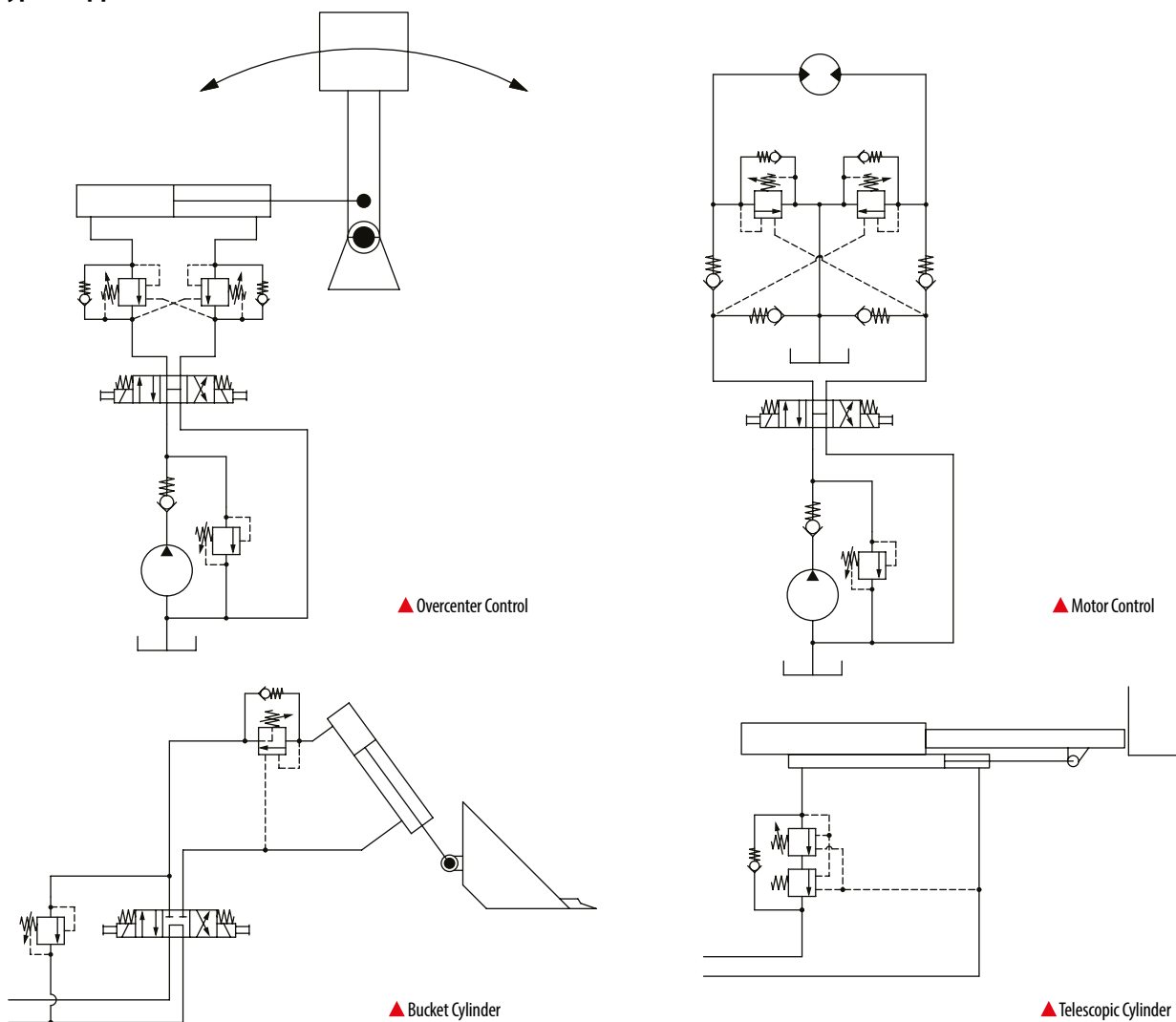

Motion Control Valves

Quick Reference

Overcenter Valve	Model No.	Cavity	Description	Flow*	Pressure	Page
	CP448-1	CP08-3L	Overcenter Valve, Standard, Direct Acting, Internal Drain, Port 3 Pilot	19 l/min [5 US gpm]	350 bar [5000 psi]	10
	1CE30	A6610	Overcenter Valve, Standard, Direct Acting, Internal Drain, Port 3 Pilot	30 l/min [8 US gpm]	350 bar [5000 psi]	12
	1CEH30	A6610	Overcenter Valve, Standard, Direct Acting, Internal Drain, Port 3 Pilot	30 l/min [8 US gpm]	430 bar [6200 psi]	14
	1CE90	A12336	Overcenter Valve, Standard, Direct Acting, Internal Drain, Port 3 Pilot	90 l/min [24 US gpm]	350 bar [5000 psi]	16
	1CEH90	A12336	Overcenter Valve, Standard, Direct Acting, Internal Drain, Port 3 Pilot	90 l/min [24 US gpm]	430 bar [6200 psi]	18
	1CE120	A877	Overcenter Valve, Standard, Differential Area, Internal Drain, Port 3 Pilot	120 l/min [32 US gpm]	350 bar [5000 psi]	20
	1CE140	A20081	Overcenter Valve, Standard, Direct Acting, Internal Drain, Port 3 Pilot	140 l/min [37 US gpm]	420 bar [6100 psi]	22
	1CE300	A6935	Overcenter Valve, Standard, Differential Area, Internal Drain, Port 3 Pilot	300 l/min [80 US gpm]	350 bar [5000 psi]	24
	1SE30	A20090-T11A	Overcenter Valve, Standard, Direct Acting, Internal Drain, Port 3 Pilot	30 l/min [8 US gpm]	350 bar [5000 psi]	26
	1SE90	A20092-T2A	Overcenter Valve, Standard, Direct Acting, Internal Drain, Port 3 Pilot	90 l/min [24 US gpm]	350 bar [5000 psi]	27
	1SE140	A20094-T17A	Overcenter Valve, Standard, Direct Acting, Internal Drain, Port 3 Pilot	140 l/min [37 US gpm]	420 bar [6100 psi]	28

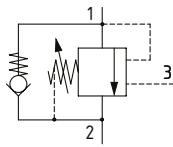

Overcenter Valve	Model No.	Cavity	Description	Flow*	Pressure	Page
	VCB 06-EN Note: Non-Preferred	NCS06/3	Overcenter Valve, Standard, Differential Area, Internal Drain, Port 1 Pilot	60 l/min [16 US gpm]	350 bar [5000 psi]	29

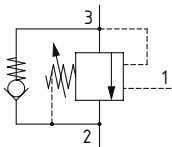

*Flow ratings are for reference only. Refer to individual product page for performance information.

Motion Control Valves

Quick Reference

Overcenter Valve	Model No.	Cavity	Description	Flow*	Pressure	Page
	1CER30	A6610	Overcenter Valve, Part Balanced, Direct Acting, Internal Drain, Port 3 Pilot	30 l/min [8 US gpm]	350 bar [5000 psi]	31
	1CERH30	A6610	Overcenter Valve, Part Balanced, Direct Acting, Internal Drain, Port 3 Pilot	30 l/min [8 US gpm]	430 bar [6200 psi]	33
	1CER90	A12336	Overcenter Valve, Part Balanced, Direct Acting, Internal Drain, Port 3 Pilot	90 l/min [24 US gpm]	350 bar [5000 psi]	35
	1CERH90	A12336	Overcenter Valve, Part Balanced, Direct Acting, Internal Drain, Port 3 Pilot	90 l/min [24 US gpm]	430 bar [6200 psi]	37
	1CER140	A20081	Overcenter Valve, Part Balanced, Direct Acting, Internal Drain, Port 3 Pilot	140 l/min [37 US gpm]	420 bar [6100 psi]	39
	1SER30	A20090-T11A	Overcenter Valve, Part Balanced, Direct Acting, Internal Drain, Port 3 Pilot	30 l/min [8 US gpm]	350 bar [5000 psi]	41
	1SER90	A20092-T2A	Overcenter Valve, Part Balanced, Direct Acting, Internal Drain, Port 3 Pilot	90 l/min [24 US gpm]	350 bar [5000 psi]	42
	1SER140	A20094-T17A	Overcenter Valve, Part Balanced, Direct Acting, Internal Drain, Port 3 Pilot	140 l/min [37 US gpm]	420 bar [6100 psi]	43

Overcenter Valve	Model No.	Cavity	Description	Flow*	Pressure	Page
	1CEB30	A6610	Overcenter Valve, Fully Balanced, Direct Acting, Atmospheric Vent, Port 3 Pilot	30 l/min [8 US gpm]	350 bar [5000 psi]	44
	1CEB90	A12336	Overcenter Valve, Fully Balanced, Direct Acting, Atmospheric Vent, Port 3 Pilot	90 l/min [24 US gpm]	350 bar [5000 psi]	46
	1CEB120	A877	Overcenter Valve, Fully Balanced, Differential Area, Atmospheric Vent, Port 3 Pilot	120 l/min [32 US gpm]	350 bar [5000 psi]	48
	1CEB300	A6935	Overcenter Valve, Fully Balanced, Differential Area, Atmospheric Vent, Port 3 Pilot	300 l/min [80 US gpm]	350 bar [5000 psi]	50
	1SEB30	A20090-T11A	Overcenter Valve, Fully Balanced, Direct Acting, Atmospheric Vent, Port 3 Pilot	30 l/min [8 US gpm]	350 bar [5000 psi]	52
	1SEB90	A20092-T2A	Overcenter Valve, Fully Balanced, Direct Acting, Atmospheric Vent, Port 3 Pilot	90 l/min [24 US gpm]	350 bar [5000 psi]	53

Overcenter Valve	Model No.	Cavity	Description	Flow*	Pressure	Page
	1CEBD30	A20530	Overcenter Valve, Fully Balanced, Direct Acting, External Drain, Port 3 Pilot	30 l/min [8 US gpm]	350 bar [5000 psi]	54
	1CEBD90	A12196	Overcenter Valve, Fully Balanced, Direct Acting, External Drain, Port 3 Pilot	90 l/min [24 US gpm]	350 bar [5000 psi]	55
	1CEBD120	A6726	Overcenter Valve, Fully Balanced, Differential Area, External Drain, Port 3 Pilot	180 l/min [47 US gpm]	400 bar [5800 psi]	56
	1CEBD300	A13098	Overcenter Valve, Fully Balanced, Differential Area, External Drain, Port 3 Pilot	300 l/min [80 US gpm]	350 bar [5000 psi]	57

*Flow ratings are for reference only. Refer to individual product page for performance information.

Motion Control Valves

Quick Reference

Overcenter Valve	Model No.	Cavity	Description	Flow*	Pressure	Page
	1CEL30	A6610	Overcenter Valve, Two Stage Counterbalance, Direct Acting, Port 3 Pilot	30 l/min [8 US gpm]	380 bar [5500 psi]	58
	1CEL90	A12336	Overcenter Valve, Two Stage Counterbalance, Direct Acting, Port 3 Pilot	90 l/min [24 US gpm]	380 bar [5500 psi]	60
	1CEL140	A20081	Overcenter Valve, Two Stage Counterbalance, Direct Acting, Port 3 Pilot	140 l/min [37 US gpm]	380 bar [5500 psi]	62
	1SEL30	A20090-T11A	Overcenter Valve, Two Stage Counterbalance, Direct Acting, Port 3 Pilot	30 l/min [8 US gpm]	380 bar [5500 psi]	64
	1SEL90	A20092-T2A	Overcenter Valve, Two Stage Counterbalance, Direct Acting, Port 3 Pilot	90 l/min [24 US gpm]	380 bar [5500 psi]	65
	1SEL140	A20094-T17A	Overcenter Valve, Two Stage Counterbalance, Direct Acting, Port 3 Pilot	140 l/min [37 US gpm]	380 bar [5500 psi]	66
Overcenter Valve	Model No.	Cavity	Description	Flow*	Pressure	Page
	1CPBD30	A20530	Overcenter Valve, Zero Differential, Poppet Type, External Drain, Port 3 Pilot	30 l/min [8 US gpm]	350 bar [5000 psi]	67
	1CPBD90	A12196	Overcenter Valve, Zero Differential, Poppet Type, External Drain, Port 3 Pilot	90 l/min [24 US gpm]	350 bar [5000 psi]	68
	1CPBD120	A6726	Overcenter Valve, Zero Differential, Poppet Type, External Drain, Port 3 Pilot	180 l/min [47 US gpm]	400 bar [5800 psi]	69
	1CPBD300	A13098	Overcenter Valve, Zero Differential, Poppet Type, External Drain, Port 3 Pilot	300 l/min [80 US gpm]	400 bar [5800 psi]	70
Overcenter Valve	Model No.	Cavity	Description	Flow*	Pressure	Page
	1CPPD90	A12196	Zero Differential Valve, Normally Closed, Poppet Type, External Drain, Port 3 Pilot	90 l/min [24 US gpm]	350 bar [5000 psi]	71
Dual Overcenter Valves	Model No.	Cavity	Description	Flow*	Pressure	Page
	1CEEC35	Catalog HIC	Dual Counterbalance Valve, Standard, Direct Acting with Makeup Checks	30 l/min [8 US gpm]	350 bar [5000 psi]	72
	1CEEC95	Catalog HIC	Dual Counterbalance Valve, Standard, Direct Acting with Makeup Checks	90 l/min [24 US gpm]	350 bar [5000 psi]	73
	1CEEC150	Catalog HIC	Dual Counterbalance Valve, Standard, Differential Area with Makeup Checks	120 l/min [32 US gpm]	350 bar [5000 psi]	74
	1CEEC350	Catalog HIC	Dual Counterbalance Valve, Standard, Differential Area with Makeup Checks	300 l/min [80 US gpm]	350 bar [5000 psi]	75

*Flow ratings are for reference only. Refer to individual product page for performance information.

Motion Control Valves

Quick Reference

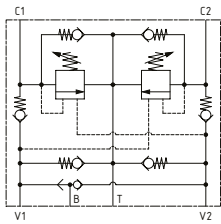
Dual Overcenter Valves	Model No.	Cavity	Description	Flow*	Pressure	Page
	1CEESH35	Catalog HIC	Dual Counterbalance Valve, Standard, Direct Acting with Makeup Checks and Shuttle Valve	30 l/min [8 US gpm]	350 bar [5000 psi]	76
	1CEESH95	Catalog HIC	Dual Counterbalance Valve, Standard, Direct Acting with Makeup Checks and Shuttle Valve	90 l/min [24 US gpm]	350 bar [5000 psi]	77
	1CEESH150	Catalog HIC	Dual Counterbalance Valve, Standard, Differential Area with Makeup Checks and Shuttle Valve	120 l/min [32 US gpm]	350 bar [5000 psi]	78
	1CEESH350	Catalog HIC	Dual Counterbalance Valve, Standard, Differential Area with Makeup Checks and Shuttle Valve	300 l/min [80 US gpm]	350 bar [5000 psi]	79

*Flow ratings are for reference only. Refer to individual product page for performance information.

Motion Control Valves

CP448-1

Overcenter Valve, Standard, Direct Acting, Internal Drain, Port 3 Pilot

350 bar [5000 psi] • 19 l/min [5 US gpm]

DESCRIPTION AND OPERATION

This is a direct acting overcenter valve, which is a pilot assisted relief with a free flow check. With the relief valve set at approximately 1.3 times the maximum load induced pressure, the valve will prevent flow from port 1 to 2. When pilot pressure is applied to port 3, the valve will meter the flow from port 1 to 2, compensating for any change in pilot pressure due to over-running or unstable loads. Free flow takes place from port 2 to port 1 through the check portion of the valve. These valves are ideal in most applications bringing stability, load holding, and hose failure protection when the valve is mounted onto or into the actuator. The spring chamber is connected to the valve port 2, so any back pressure will increase the pilot pressure required to keep the valve open and the pressure at which the valve will open as a relief valve. This is also available in a dual housing for bi-directional control.

SCHEMATIC

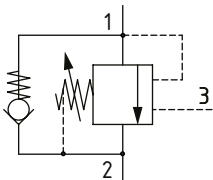

PERFORMANCE DATA

Rated pressure	350 bar [5000 psi]
Rated flow	19 l/min [5 US gpm]
Max total relief pressure	350 bar [5000 psi]
Max recommended load pressure at max setting	270 bar [3900 psi]
Pilot Ratio	3:1, 4.5:1, 8:1
Leakage	10 drops/min @ 70% of crack pressure
Weight	0.16 kg [0.36 lb]
Cavity	CP08-3L

DIMENSIONS

mm [in]

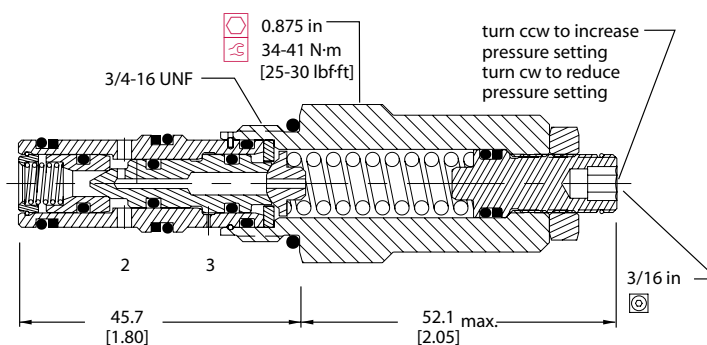

PERFORMANCE CURVES

Pressure Drop

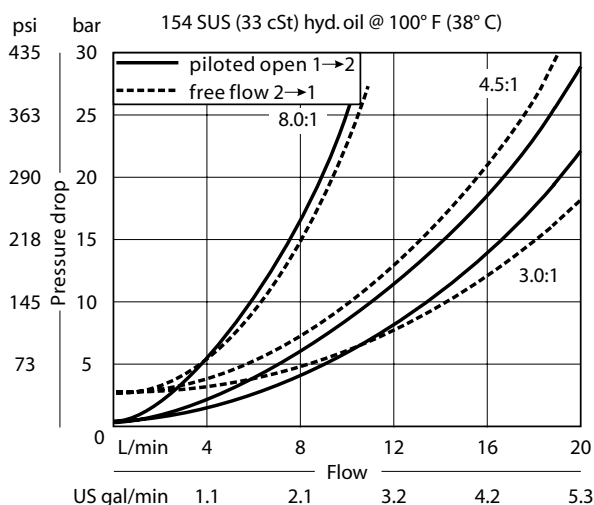

Motion Control Valves

CP448-1

Overcenter Valve, Standard, Direct Acting, Internal Drain, Port 3 Pilot
 350 bar [5000 psi] • 19 l/min [5 US gpm]

■ SCHEMATIC

CP448-2 (dual)

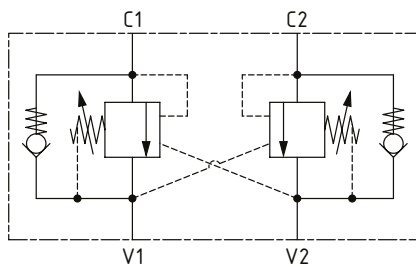

■ DIMENSIONS

mm [in]

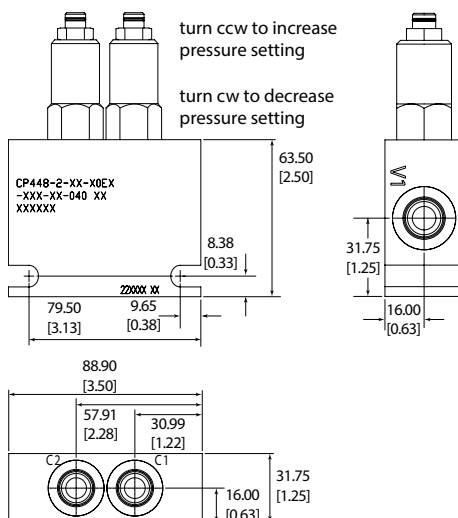

■ MODEL CODE

CP448 - 1 - B - 6S - E - B - 075 - 3.0 - 040

Basic Code

CP448-1 - Cartridge and Housing
 CP448-2 - Cartridges and Dual Housing

Seal Option

Code	Seal kit
B-Buna - N	120238
V-Viton	120239

Housing

Code	Ports & Material	Housing Model Code	Dual Housing Model Code
0	No housing		
2B	AL, 1/4 BSP	CP08-3L-2B	
3B	AL, 3/8 BSP	CP08-3L-3B	CP448-2-3B
S3B	Steel, 3/8 BSP	CP08-3L-S3B	CP448-2-S3B
4S	AL, #4 SAE	CP08-3L-4S	CP448-2-4S
6S	AL, #6 SAE	CP08-3L-6S	CP448-2-6S
S6S	Steel, #6 SAE	CP08-3L-S6S	

* Aluminum bodies are to be used for pressures less than 210 bar [3000 psi].
 * Additional housings available

Adjustment Option

E - External

Free Flow Check Crack Pressure

Code	Bar	Psi
040	2.76	[40]

Pilot Ratio

3.0 - 3.0:1
 4.5 - 4.5:1
 8.0 - 8.0:1

Pressure Setting

Code x10 - Pressure setting in psi (10 psi increments within specified Pressure Range)
 XXX - Standard setting (see Pressure Range for value)
 Example:

Code	Bar	Psi
075	52	[750]

Pressure Range

Code	Pilot Ratio 3.0		Pilot Ratio 4.5		Pilot Ratio 8.0	
	Psi	Bar	Psi	Bar	Psi	Bar
A	600-1800	[41-124]	800-2700	[55-186]	1500-5000	[103-350]
Standard Setting	1000	[69]	1500	[103]	2500	[172]
B	1000-3500	[269-240]	1500-5000	[103-350]		
Standard Setting	1500	[103]	2500	[172]		
C	1800-5000	[124-350]				
Standard Setting	2500	[172]				

Motion Control Valves

1CE30

Overcenter Valve, Standard, Direct Acting, Internal Drain, Port 3 Pilot

350 bar [5000 psi] • 30 l/min [8 US gpm]

DESCRIPTION AND OPERATION

This is a direct acting overcenter valve, which is a pilot assisted relief with a free flow check. With the relief valve set at approximately 1.3 times the maximum load induced pressure, the valve will prevent flow from port 1 to 2. When pilot pressure is applied to port 3, the valve will meter the flow from port 1 to 2, compensating for any change in pilot pressure due to over-running or unstable loads. Free flow takes place from port 2 to port 1 through the check portion of the valve. These valves are ideal in most applications bringing stability, load holding, and hose failure protection when the valve is mounted onto or into the actuator. The spring chamber is connected to the valve port 2, so any back pressure will increase the pilot pressure required to keep the valve open and the pressure at which the valve will open as a relief valve. This is also available in a dual housing for bi-directional control.

SCHEMATIC

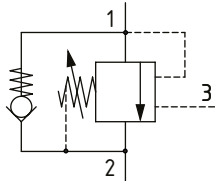

PERFORMANCE DATA

Rated pressure	350 bar [5000 psi]
Rated flow	30 l/min [8 US gpm]
Max total relief pressure	350 bar [5000 psi]
Max recommended load pressure at max setting	270 bar [3900 psi]
Pilot Ratio	2.5:1, 5:1, 10:1
Leakage	0.3 ml/min nominal [5 drops/min]
Weight	0.15 kg [0.33 lb]
Cavity	A6610

DIMENSIONS

mm [in]

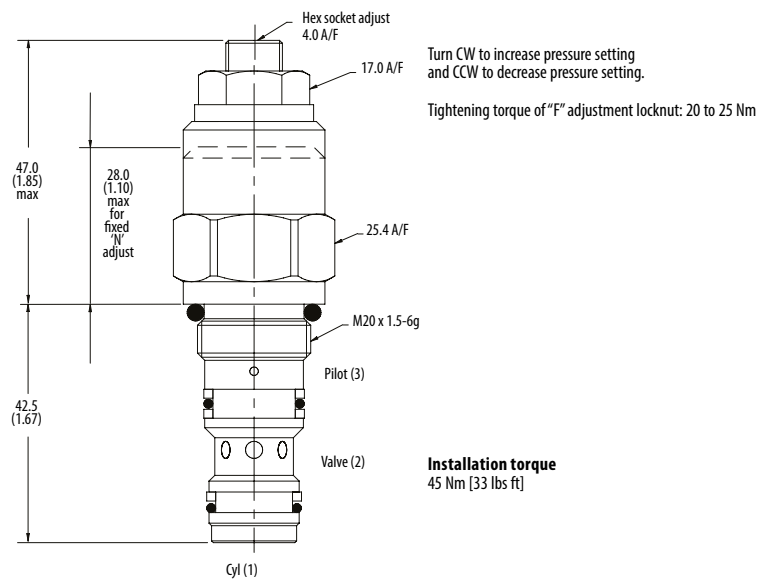

PERFORMANCE CURVES

Pressure Drop

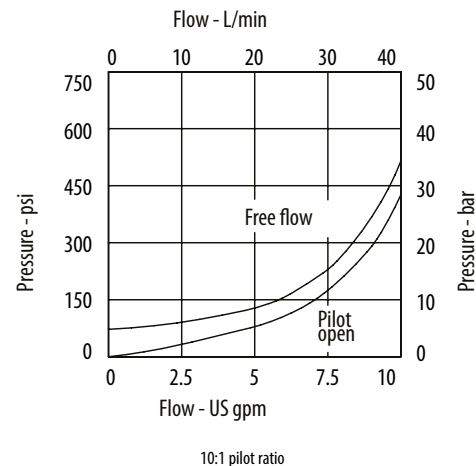
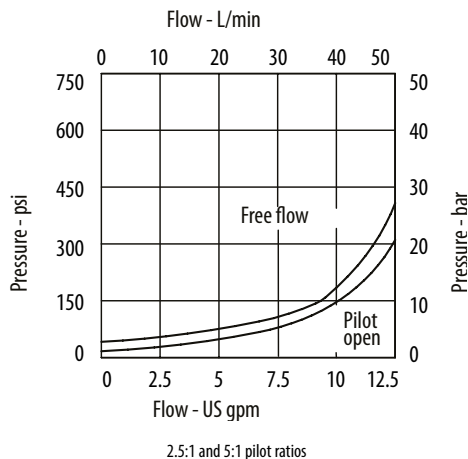

Motion Control Valves

1CE30

Overcenter Valve, Standard, Direct Acting, Internal Drain, Port 3 Pilot

350 bar [5000 psi] • 30 l/min [8 US gpm]

■ SCHEMATIC

1CEE34 (dual)

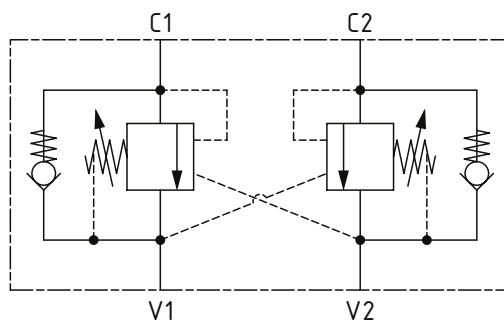

■ DIMENSIONS

mm [in]

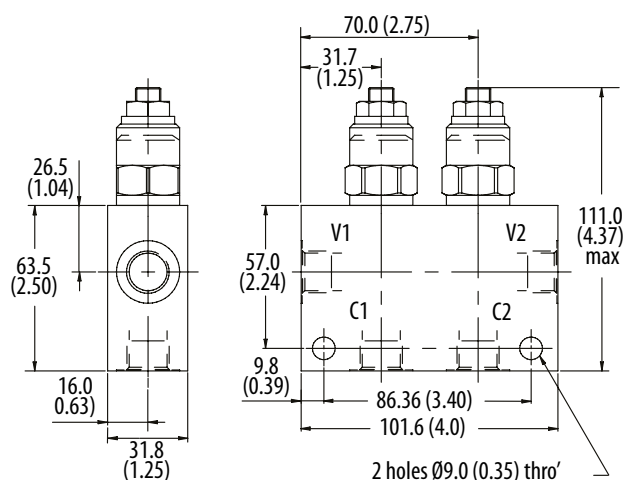

■ MODEL CODE

1CE35 - F - 3W - 35 - S - 5 - 377 - 210

Basic Code

1CE30 - No housing
1CE35 - Cartridge and housing
1CEE34 - Cartridge and dual housing

Adjustment Option

F - External
G - Tamper Resistant
N - Non-adjustable option, contact technical support

Housing

Code	Ports	Aluminum single	Steel single	Aluminum dual	Steel dual
Omit	No housing				
3W	3/8" BSP	B6743	B12823	B6836	B13803
6T	#6 SAE	B10536	B11560	B10805	B11630
8T	#8 SAE	B7884	B11811	B30237	B11812

* Aluminum bodies are to be used for pressures less than 210 bar [3000 psi].

* Additional housings available

Pressure Setting

Code - Pressure setting in bar (10 bar increments within specified Pressure Range)

XXX - Standard setting (see Pressure Range for value)

Example:

Code	Bar	Psi
210	210	[3000]

Housing Material

Omit - Aluminum/No housing

377 - Steel

Pilot Ratio

2 - 2.5:1

5 - 5:1

10 - 10:1

Seal Option

Code Seal kit

S-Buna - N SK395

SV-Viton SK395V

Pressure Range

Code	Pilot Ratio 2		Pilot Ratio 5		Pilot Ratio 10	
	Bar	Psi	Bar	Psi	Bar	Psi
20	70-210	[1015-3000]	70-120	[1015-3000]	100-210	[1450-3000]
Standard setting	100	[1450]	100	[1450]	100	[1450]
35	100-350	[1450-5000]	100-350	[1450-5000]	120-350	[1740-5000]
Standard setting	210	[3000]	210	[3000]	210	[3000]

Std setting made at 4.5 l/min

Motion Control Valves

1CEH30

Overcenter Valve, Standard, Direct Acting, Internal Drain, Port 3 Pilot

430 bar [6200 psi] • 30 l/min [8 US gpm]

DESCRIPTION AND OPERATION

This is a direct acting overcenter valve, which is a pilot assisted relief with a free flow check. With the relief valve set at approximately 1.3 times the maximum load induced pressure, the valve will prevent flow from port 1 to 2. When pilot pressure is applied to port 3, the valve will meter the flow from port 1 to 2, compensating for any change in pilot pressure due to over-running or unstable loads. Free flow takes place from port 2 to port 1 through the check portion of the valve. These valves are ideal in most applications bringing stability, load holding, and hose failure protection when the valve is mounted onto or into the actuator. The spring chamber is connected to the valve port 2, so any back pressure will increase the pilot pressure required to keep the valve open and the pressure at which the valve will open as a relief valve. This is also available in a dual housing for bi-directional control.

SCHEMATIC

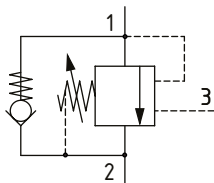

PERFORMANCE DATA

Rated pressure	430 bar [6200 psi]
Rated flow	30 l/min [8 US gpm]
Max total relief pressure	430 bar [6200 psi]
Max recommended load pressure at max setting	350 bar [5000 psi]
Pilot Ratio	3:1, 5:1
Leakage	5 drops/min at 85% of Crack Pressure
Weight	0.25 kg [0.55 lbs]
Cavity	A6610

DIMENSIONS

mm [in]

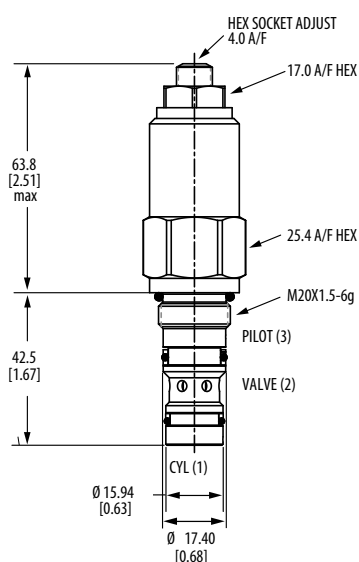

Turn CW to increase pressure setting and CCW to decrease pressure setting.

Torque lock nut to 20-25 Nm [15-18 ft lbs]

Installation torque
68-75 Nm [50-56 ft. lbs]

PERFORMANCE CURVES

Pressure Drop

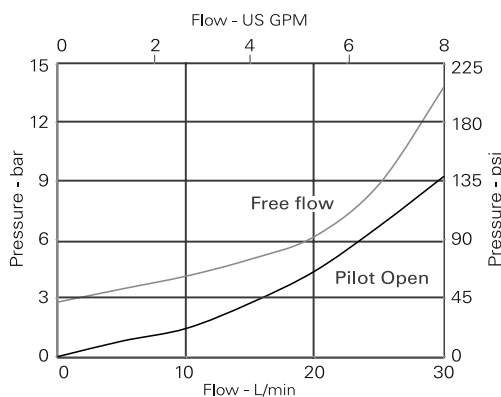

3:1 and 5:1 version

Motion Control Valves

1CEH30

Overcenter Valve, Standard, Direct Acting, Internal Drain, Port 3 Pilot

430 bar [6200 psi] • 30 l/min [8 US gpm]

■ SCHEMATIC

1CEEH34 (dual)

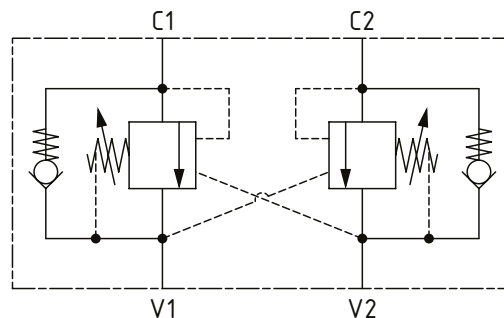

■ DIMENSIONS

mm [in]

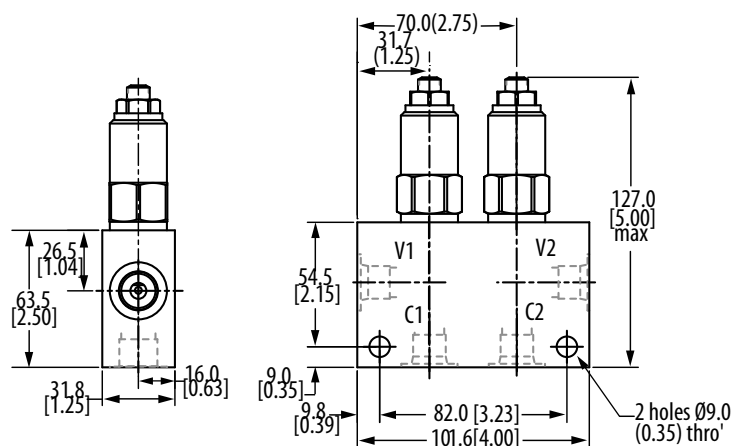

■ MODEL CODE

1CEH35 - F - 3W - 43 - S - 3 - 377 - 350

Basic Code

1CEH30 - No housing
1CEH35 - Cartridge and housing
1CEEH34 - Cartridges in dual housing

Adjustment Option

F - External

Housing

Code	Ports	Steel single	Steel dual
Omit	No housing		
3W	3/8" BSPP	B12823	B13803
8T	1/2" SAE	B11811	B11812

* Aluminum bodies are to be used for pressures less than 210 bar [3000 psi].

* Additional housings available

Pressure Range

Code	Bar	Psi
43	250-430	[3600-6200]
Standard setting	350	[5000]

Std. setting made at 4.5 l/min

Pressure Setting

Code Pressure setting in bar (10 bar increments within specified Pressure Range)
XXX - Standard setting (see Pressure Range for value)
Example:

Code	Bar	Psi
350	350	[5000]

Housing Material

Omit - No housing
377 - Steel

Pilot Ratio

3 - 3:1
5 - 5:1

Seal Option

Code	Seal kit
S-Buna - N	9900925-000
SV-Viton	9900926-000

Motion Control Valves

1CE90

Overcenter Valve, Standard, Direct Acting, Internal Drain, Port 3 Pilot

350 bar [5000 psi] • 90 l/min [24 US gpm]

DESCRIPTION AND OPERATION

This is a direct acting overcenter valve, which is a pilot assisted relief with a free flow check. With the relief valve set at approximately 1.3 times the maximum load induced pressure, the valve will prevent flow from port 1 to 2. When pilot pressure is applied to port 3, the valve will meter the flow from port 1 to 2, compensating for any change in pilot pressure due to over-running or unstable loads. Free flow takes place from port 2 to port 1 through the check portion of the valve. These valves are ideal in most applications bringing stability, load holding, and hose failure protection when the valve is mounted onto or into the actuator. The spring chamber is connected to the valve port 2, so any back pressure will increase the pilot pressure required to keep the valve open and the pressure at which the valve will open as a relief valve. This is also available in a dual housing for bi-directional control.

SCHEMATIC

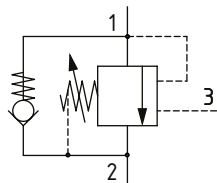

PERFORMANCE DATA

Rated pressure	350 bar [5000 psi]
Rated flow	90 l/min [24 US gpm]
Max total relief pressure	350 bar [5000 psi]
Max recommended load pressure at max setting	270 bar [3900 psi]
Pilot Ratio	4:1, 8:1
Leakage	0.3 ml/min nominal [5 drops/min]
Weight	0.29 kg [0.63 lb]
Cavity	A12336

DIMENSIONS

mm [in]

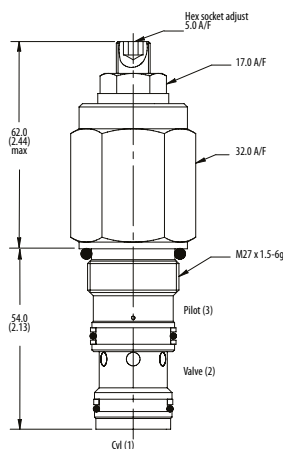

Turn CW to increase pressure setting and CCW to decrease pressure setting.

Torque lock nut to 20-25 Nm [15-18 ft lbs]

Installation torque
60 Nm [44 ft. lbs]

PERFORMANCE CURVES

Pressure Drop

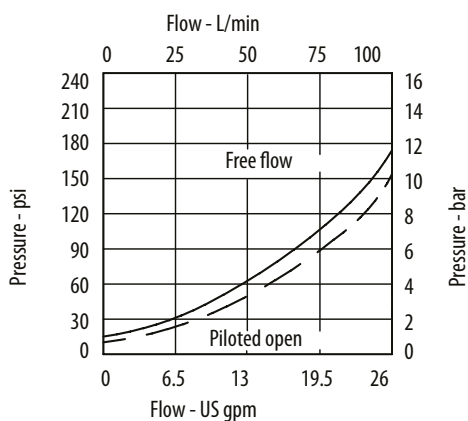

4:1 Version

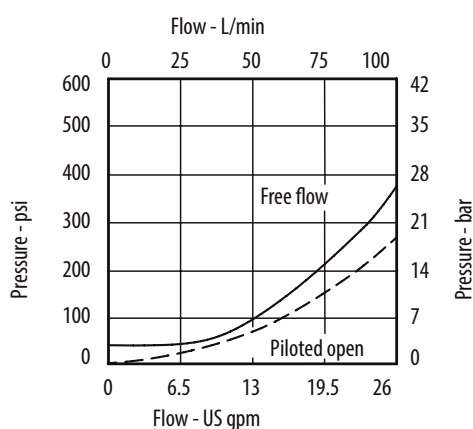

8:1 Pilot Ratio

Motion Control Valves

1CE90

Overcenter Valve, Standard, Direct Acting, Internal Drain, Port 3 Pilot

350 bar [5000 psi] • 90 l/min [24 US gpm]

■ SCHEMATIC

1CEE95 (dual)

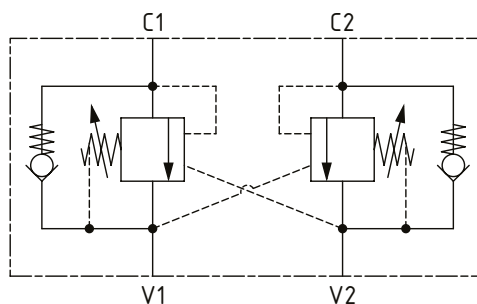

■ DIMENSIONS

mm [in]

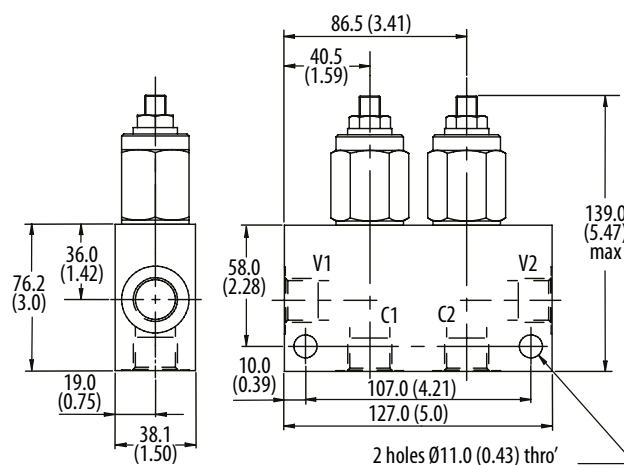

■ MODEL CODE

1CE95 - F - 4W - 35 - S - 4 - 377 - 200

Basic Code

1CE90 - No housing
1CE95 - Cartridge and housing
1CEE95 - Cartridges and dual housing

Adjustment Option

F - External
N - Non-adjustable option, contact technical support.

Housing

Code	Ports	Aluminum single	Steel single	Aluminum dual	Steel dual
Omit	No housing				
4W	1/2" BSP Valve & Cyl Port 1/4" BSP Pilot Port	B13625	B13626	C13627	C13628
8T	1/2" SAE Valve & Cyl Port 1/4" SAE Pilot Port	B10806	B10922	C10807	C11561

* Aluminum bodies are to be used for pressures less than 210 bar [3000 psi].

* Additional housings available

Pressure Range

Code	Bar	Psi
20	70-225	[1015-3260]
Standard Setting	100	[1450]
35	200-350	[2900-5000]
Standard Setting	210	[3000]

Std setting made at 4.5 L/min

Pressure Setting

Code Pressure setting in bar (10 bar increments within specified Pressure Range)
XXX-Standard setting (see Pressure Range for value)
Example:

Code	Bar	Psi
200	200	[2900]

Housing Material

Omit - Aluminum/No housing
377 - Steel

Pilot Ratio

4 - 4:1
8 - 8:1

Seal Option

Code	Seal kit
S - Buna-N	SK633
SV - Viton	SK633V

Motion Control Valves

1CEH90

Overcenter Valve, Standard, Direct Acting, Internal Drain, Port 3 Pilot

430 bar [6200 psi] • 90 l/min [24 US gpm]

DESCRIPTION AND OPERATION

This is a direct acting overcenter valve, which is a pilot assisted relief with a free flow check. With the relief valve set at approximately 1.3 times the maximum load induced pressure, the valve will prevent flow from port 1 to 2. When pilot pressure is applied to port 3, the valve will meter the flow from port 1 to 2, compensating for any change in pilot pressure due to over-running or unstable loads. Free flow takes place from port 2 to port 1 through the check portion of the valve. These valves are ideal in most applications bringing stability, load holding, and hose failure protection when the valve is mounted onto or into the actuator. The spring chamber is connected to the valve port 2, so any back pressure will increase the pilot pressure required to keep the valve open and the pressure at which the valve will open as a relief valve. This is also available in a dual housing for bi-directional control.

SCHEMATIC

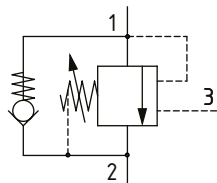

PERFORMANCE DATA

Rated pressure	430 bar [6200 psi]
Rated flow	90 l/min [24 US gpm]
Max total relief pressure	430 bar [6200 psi]
Max recommended load pressure at max setting	350 bar [5000 psi]
Pilot Ratio	4:1
Leakage	5 drops/min @ 85% of crack pressure
Weight	0.6 kg [1.32 lb]
Cavity	A12336

DIMENSIONS

mm [in]

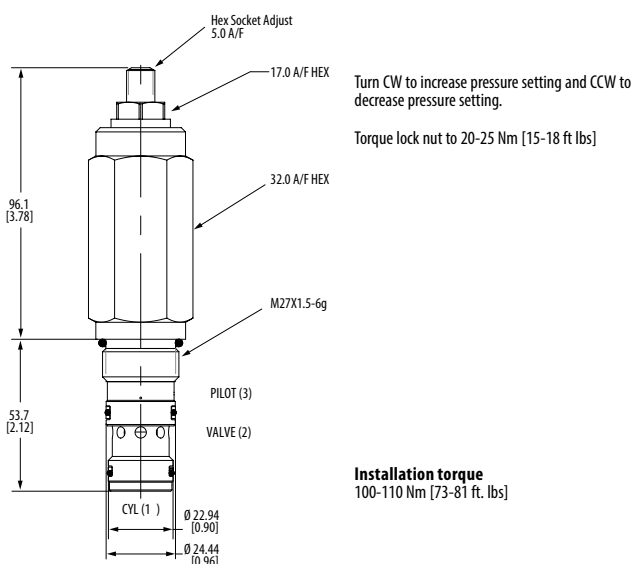

PERFORMANCE CURVES

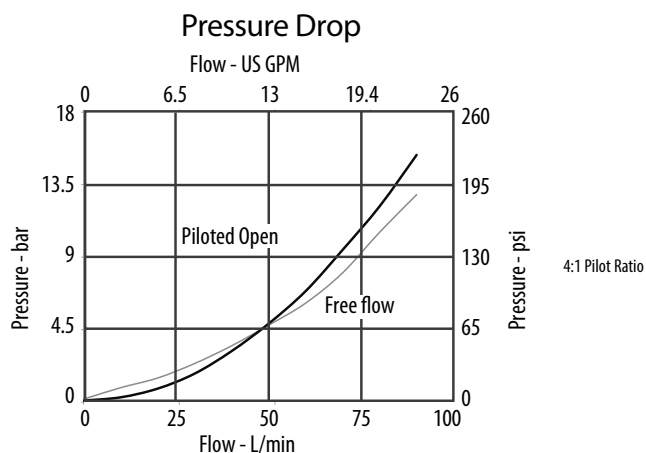

Motion Control Valves

1CEH90

Overcenter Valve, Standard, Direct Acting, Internal Drain, Port 3 Pilot

430 bar [6200 psi] • 90 l/min [24 US gpm]

■ SCHEMATIC

1CEEH95 (dual)

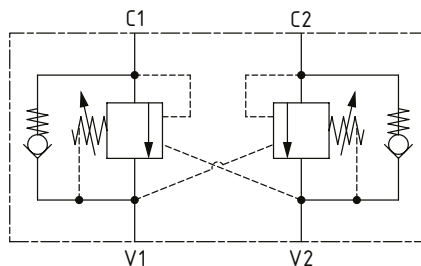

■ DIMENSIONS

mm [in]

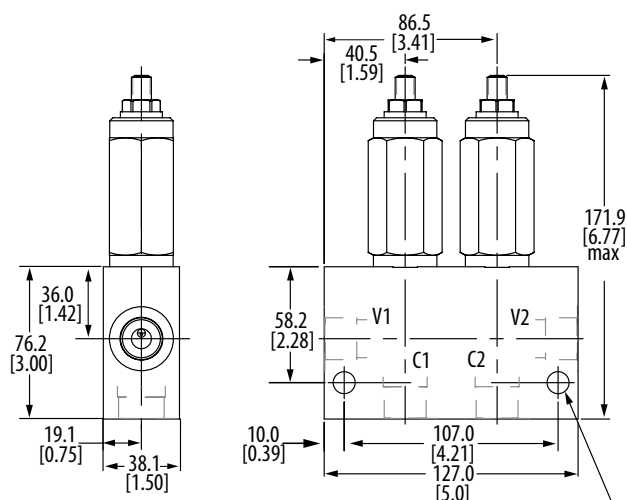

■ MODEL CODE

1CEH95 - F - 4W - 43 - S - 4 - 377 - 350

Basic Code

1CEH90 - No housing
1CEH95 - Cartridge and housing
1CEEH95 - Cartridges and dual housing

Adjustment Option

F - External

Housing

Code	Ports	Steel single	Steel dual
Omit	No housing		
4W	1/2" BSP Valve & Cyl Port 1/4" BSP Pilot Port	B13626	C13628
8T	1/2" SAE Valve & Cyl Port 1/4" SAE Pilot Port	B10922	C11561

* Aluminum bodies are to be used for pressures less than 210 bar [3000 psi].
* Additional housings available

Pressure Setting

Code Pressure setting in bar (10 bar increments within specified Pressure Range)
XXX-Standard setting (see Pressure Range for value)
Example:

Code	Bar	Psi
350	350	[5000]

Housing Material

Omit - No housing
377 - Steel

Pilot Ratio

4 - 4:1

Seal Option

Code	Seal kit
S-Buna-N	9900927-000
SV-Viton	9900928-000

Pressure Range

Code	Bar	Psi
43	275-430	[3990-6200]
Standard Setting	350	[5000]

Std. setting made at 4.5 l/min

Motion Control Valves

1CE120

Overcenter Valve, Standard, Differential Area, Internal Drain, Port 3 Pilot

350 bar [5000 psi] • 120 l/min [32 US gpm]

DESCRIPTION AND OPERATION

This is a differential area overcenter valve, which is a pilot assisted relief with a free flow check. With the relief valve set at around 1.3 times the maximum load induced pressure, the valve will prevent flow from taking place between ports 1 and 2. When pilot pressure is applied to port 3, the valve will meter the flow from port 1 to 2, compensating for any change in pilot pressure due to over-running or unstable loads. Free flow takes place from port 2 to port 1 through the check portion of the valve. These valves are ideal in most applications bringing stability, load holding, and hose failure protection when the valve is mounted onto or into the actuator. The spring chamber is connected to the valve port 2 so any back pressure will increase the pilot pressure required to keep the valve open and the pressure at which the valve will open as a relief valve. This is also available in a dual housing for bi-directional control.

SCHEMATIC

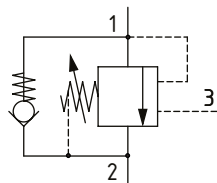

PERFORMANCE DATA

Rated pressure	350 bar [5000 psi]
Rated flow	120 l/min [32 US gpm]
Max total relief pressure	350 bar [5000 psi]
Max recommended load pressure at max setting	270 bar [3900 psi]
Pilot Ratio	3.5:1
Leakage	0.3 ml/min nominal [5 drops/min]
Weight	0.59 kg [1.30 lb]
Cavity	A877

DIMENSIONS

mm [in]

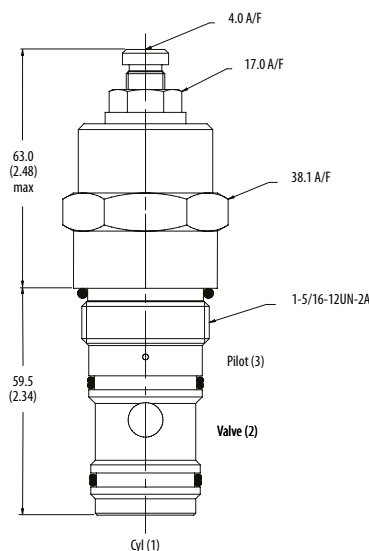

Turn CW to increase pressure setting and CCW to decrease pressure setting.

Torque lock nut to 20-25 Nm [15-18 ft lbs]

Installation Torque

100 Nm [74 ft. lbs]

PERFORMANCE CURVES

Pressure Drop

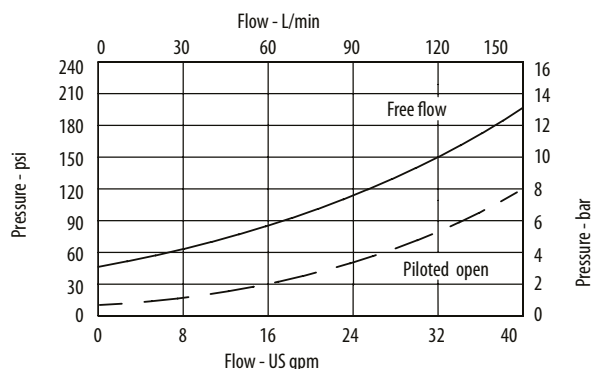

Motion Control Valves

1CE120

Overcenter Valve, Standard, Differential Area, Internal Drain, Port 3 Pilot

350 bar [5000 psi] • 120 l/min [32 US gpm]

■ SCHEMATIC

1CEE150 (dual)

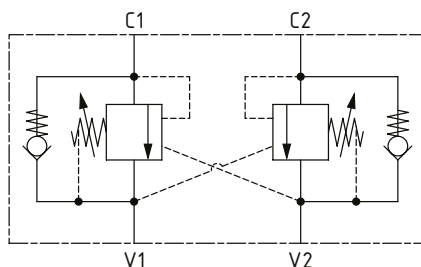

■ DIMENSIONS

mm [in]

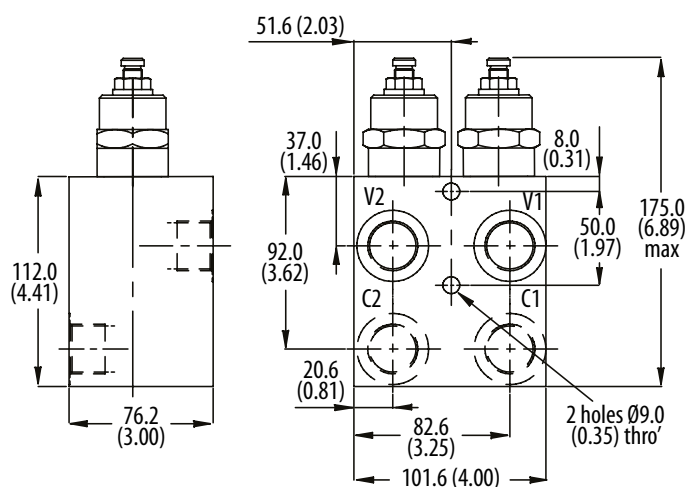

■ MODEL CODE

1CE150 - F - 6W - 35 - S - 3 - 377 - 210

Basic Code

1CE120 - No housing
1CE150 - Cartridge and housing
1CEE150 - Cartridges and dual housing

Adjustment Option

F - External

Housing

Code	Ports	Aluminum single	Steel single	Aluminum dual	Steel dual
Omit	No housing				
6W	3/4" BSP Valve & Cyl Port. 1/4" BSP Pilot Port	B6898	B5544	C2543	C1200
12T	3/4" SAE Valve & Cyl Port. 1/4" SAE Pilot Port	B8200		C10629	C16434
16T	1" SAE Valve & Cyl Port. 1/4" SAE Pilot Port	B10708	B11814		

* Aluminum bodies are to be used for pressures less than 210 bar [3000 psi].

* Additional housings available

Pressure Setting

Code Pressure setting in bar (10 bar increments within specified Pressure Range)
XXX-Standard setting (see Pressure Range for value)
Example:

Code	Bar	Psi
210	210	[3000]

Housing Material

Omit - Aluminum/No housing
377 - Steel

Pilot Ratio

3 - 3.5:1

Seal Option

Code	Seal kit
S-Buna-N	SK417
SW-Viton	SK417V

Pressure Range

Code	Bar	Psi
35	70-350	[3015-5000]
Standard Setting	210	[3000]

Std. setting made at 4.5 l/min

Motion Control Valves

1CE140

Overcenter Valve, Standard, Direct Acting, Internal Drain, Port 3 Pilot

420 bar [6100 psi] • 140 l/min [37 US gpm]

DESCRIPTION AND OPERATION

This is a direct acting overcenter valve, which is a pilot assisted relief with a free flow check. With the relief valve set at approximately 1.3 times the maximum load induced pressure, the valve will prevent flow from port 1 to 2. When pilot pressure is applied to port 3, the valve will meter the flow from port 1 to 2, compensating for any change in pilot pressure due to over-running or unstable loads. Free flow takes place from port 2 to port 1 through the check portion of the valve. These valves are ideal in most applications bringing stability, load holding, and hose failure protection when the valve is mounted onto or into the actuator. The spring chamber is connected to the valve port 2, so any back pressure will increase the pilot pressure required to keep the valve open and the pressure at which the valve will open as a relief valve. This is also available in a dual housing for bi-directional control.

SCHEMATIC

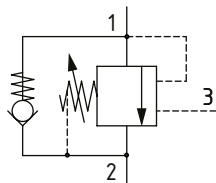

PERFORMANCE DATA

Rated pressure	420 bar [6100 psi]
Rated flow	140 l/min [37 US gpm]
Max total relief pressure	420 bar [6100 psi]
Max recommended load pressure at max setting	340 bar [4900psi]
Pilot Ratio	4:1.6:1
Leakage	0.3 ml/min nominal [5 drops/min]
Weight	1.2 kg [2.5 lb]
Cavity	A20081

DIMENSIONS

mm [in]

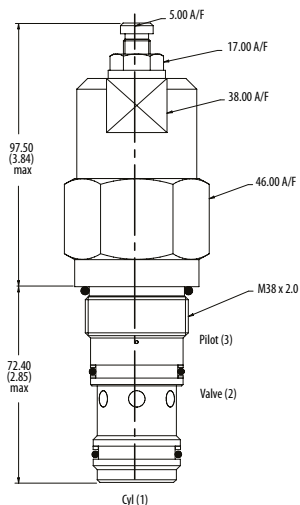

Turn CW to increase pressure setting and CCW to decrease pressure setting.

Torque lock nut to 20-25 Nm [15-18 ft lbs]

Installation Torque
150 Nm [110 ft. lbs]

PERFORMANCE CURVES

Pressure Drop

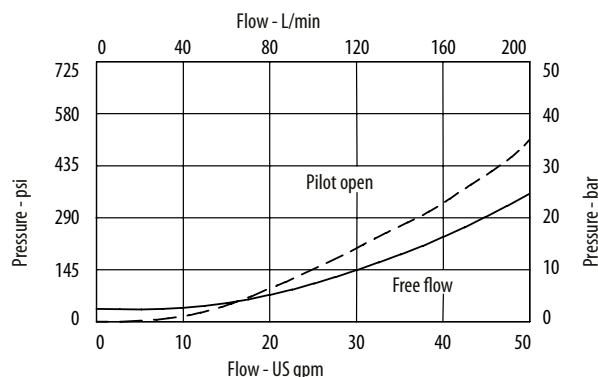

Motion Control Valves

1CE140

Overcenter Valve, Standard, Direct Acting, Internal Drain, Port 3 Pilot

420 bar [6100 psi] • 140 l/min [37 US gpm]

■ SCHEMATIC

1CEE145 (dual)

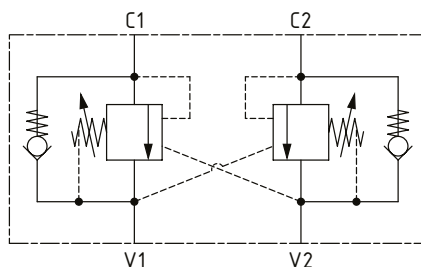

■ DIMENSIONS

mm [in]

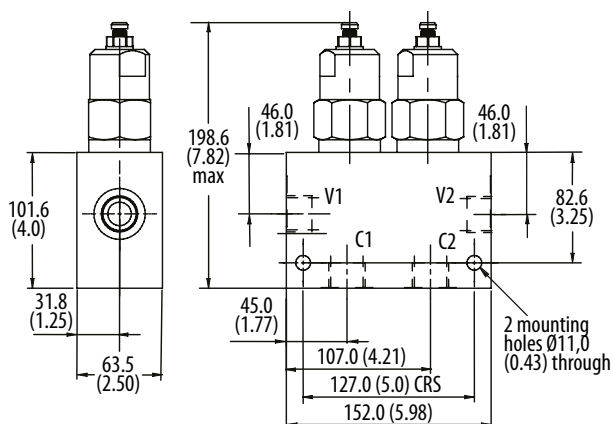

■ MODEL CODE

1CE145 - F - 6W - 40 - S - 4 - 377 - 350

Basic Code

1CE140 - No housing
1CE145 - Cartridge and housing
1CEE145 - Cartridges and dual housing

Adjustment Option

F - External

Housing

Code	Ports	Aluminum single	Steel single	Aluminum dual	Steel dual
Omit	No housing				
6W	3/4" BSP Valve & Cyl Port. 1/4" BSP Pilot Port	B20105	B20106		
8W	1" BSP Va Ive & Cyl Port. 1/4" BSP Pilot Port	B20107	B20108	C20285	C20287
16T	1" SAE Valve & Cyl Port. 1/4" SAE Pilot Port	B11946	B11947	C30105	C30106

* Aluminum bodies are to be used for pressures less than 210 bar [3000 psi].

* Additional housings available

Pressure Setting

Code Pressure setting in bar (10 bar increments within specified Pressure Range)
XXX-Standard setting (see Pressure Range for value)
Example:

Code	Bar	Psi
350	350	[5000]

Housing Material

Omit - Aluminum/No housing
377 - Steel

Pilot Ratio

4 - 4:1
6 - 6:1

Seal Option

Code	Seal Kit
S-Buna-N	SK1108
SV-Viton	SK1108V

Pressure Range

Code	Bar	Psi
20	140-250	[2000-3600]
Standard Setting	190	[2750]
30	220-330	[3200-4800]
Standard Setting	270	[3900]
40	310-420	[4500-6100]
Standard Setting	370	[5400]

Std setting made at 4.5 l/min

Motion Control Valves

1CE300

Overcenter Valve, Standard, Differential Area, Internal Drain, Port 3 Pilot

350 bar [5000 psi] • 300 l/min [80 US gpm]

DESCRIPTION AND OPERATION

This is a differential area overcenter valve, which is a pilot assisted relief with a free flow check. With the relief valve set at around 1.3 times the maximum load induced pressure, the valve will prevent flow from taking place between ports 1 and 2. When pilot pressure is applied to port 3, the valve will meter the flow from port 1 to 2, compensating for any change in pilot pressure due to over-running or unstable loads. Free flow takes place from port 2 to port 1 through the check portion of the valve. These valves are ideal in most applications bringing stability, load holding, and hose failure protection when the valve is mounted onto or into the actuator. The spring chamber is connected to the valve port 2 so any back pressure will increase the pilot pressure required to keep the valve open and the pressure at which the valve will open as a relief valve. This is also available in a dual housing for bi-directional control.

SCHEMATIC

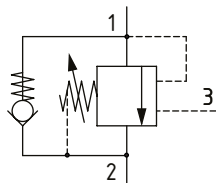

DIMENSIONS

mm [in]

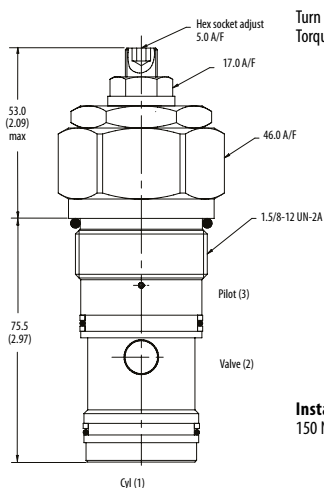

Turn CW to increase pressure setting and CCW to decrease pressure setting.
Torque lock nut to 20-25 Nm [15-18 ft lbs]

Installation torque
150 Nm [110 ft. lbs]

PERFORMANCE DATA

Rated pressure	350 bar [5000 psi]
Rated flow	300 l/min [80 US gpm]
Max total relief pressure	350 bar [5000 psi]
Max recommended load pressure at max setting	270 bar [3900 psi]
Pilot Ratio	3:1, 8:1
Leakage	4 ml/min nominal [60 drops/min]
Weight	0.91 kg [2.0 lb]
Cavity	A6935

PERFORMANCE CURVES

Pressure Drop

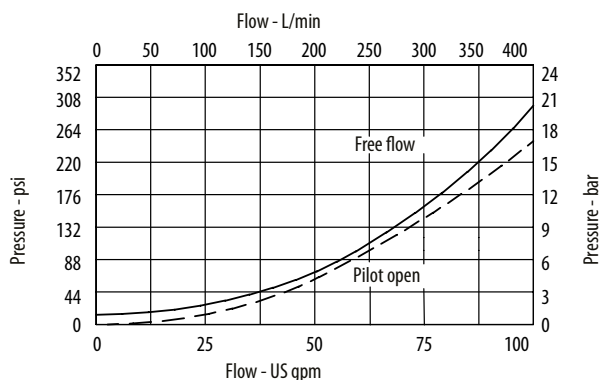

Motion Control Valves

1CE300

Overcenter Valve, Standard, Differential Area, Internal Drain, Port 3 Pilot

350 bar [5000 psi] • 300 l/min [80 US gpm]

■ SCHEMATIC

1CEE350 (dual)

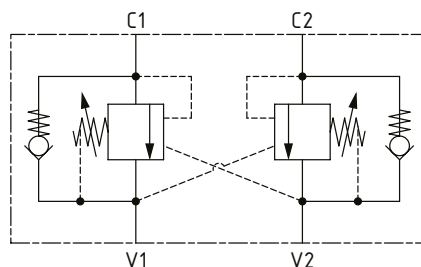

■ DIMENSIONS

mm [in]

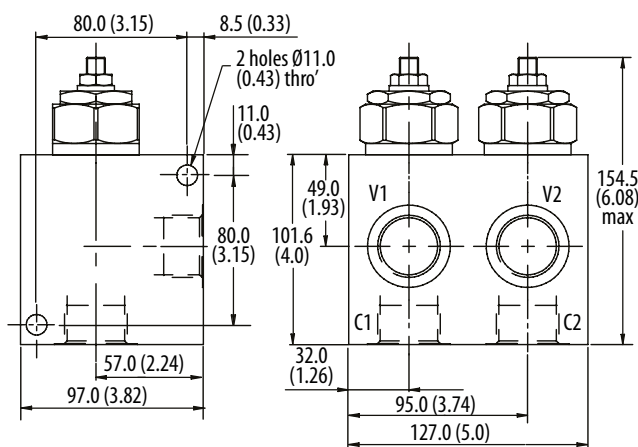

■ MODEL CODE

1CE350 - F - 10W - 35 - S - 3 - 377 - 210

Basic Code

1CE300 - No housing
1CE350 - Cartridge and housing
1CEE350 - Cartridges and dual housing

Adjustment Option

F - External

Housing

Code	Ports	Aluminum single	Steel single	Aluminum dual	Steel dual
Omit	No housing				
10W	1 1/4" BSP Valve & Cyl Port 1/4" BSP Pilot Port	B6814	B8610	C8704	C8705
20T	1 1/4" SAE Valve & Cyl Port 1/4" SAE Pilot Port	B10630	B11474	C10811	C11564

* Aluminum bodies are to be used for pressures less than 210 bar [3000 psi].

* Additional housings available

Pressure Setting

Code Pressure setting in bar (10 bar increments within specified Pressure Range)
XXX-Standard setting (see Pressure Range for value). Example:

Code	Bar	Psi
210	210	[3000]

Housing Material

Omit - Aluminum/No housing
377 - Steel

Pilot Ratio

3 - 3:1
8 - 8:1

Seal Option

Code	Seal kit
S-Buna - N	SK437
SV-Viton	SK437V

Pressure Range

Code	Bar	Psi
35	70-350	[3015-5000]
Standard Setting	210	[3000]

Std setting made at 4.5 l/min

Motion Control Valves

1SE30

Overcenter Valve, Standard, Direct Acting, Internal Drain, Port 3 Pilot

350 bar [5000 psi] • 30 l/min [8 US gpm]

DESCRIPTION AND OPERATION

This is a direct acting overcenter valve, which is a pilot assisted relief with a free flow check. With the relief valve set at approximately 1.3 times the maximum load induced pressure, the valve will prevent flow from port 1 to 2. When pilot pressure is applied to port 3, the valve will meter the flow from port 1 to 2, compensating for any change in pilot pressure due to over-running or unstable loads. Free flow takes place from port 2 to port 1 through the check portion of the valve. These valves are ideal in most applications bringing stability, load holding, and hose failure protection when the valve is mounted onto or into the actuator. The spring chamber is connected to the valve port 2, so any back pressure will increase the pilot pressure required to keep the valve open and the pressure at which the valve will open as a relief valve.

SCHEMATIC

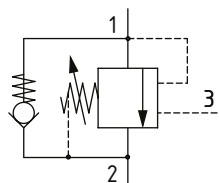

PERFORMANCE DATA

Rated pressure	350 bar [5000 psi]
Rated flow	30 l/min [8 US gpm]
Max total relief pressure	350 bar [5000 psi]
Max recommended load pressure at max setting	270 bar [3900 psi]
Pilot Ratio	2.5:1, 5:1, 10:1
Leakage	0.3 ml/min nominal [5 drops/min]
Weight	0.15 kg [0.33 lb]
Cavity	A20090-T11A

PERFORMANCE CURVES

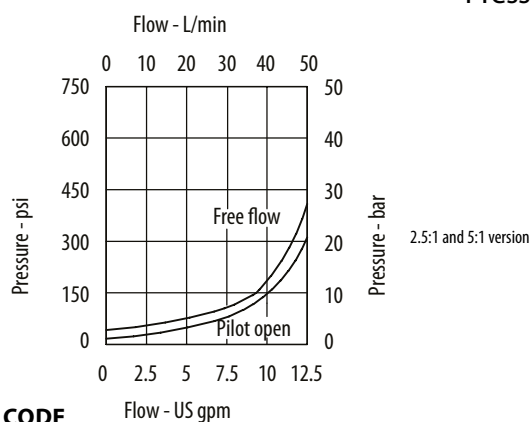

DIMENSIONS

mm [in]

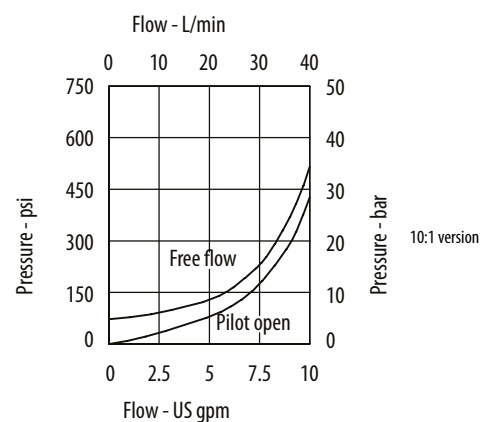
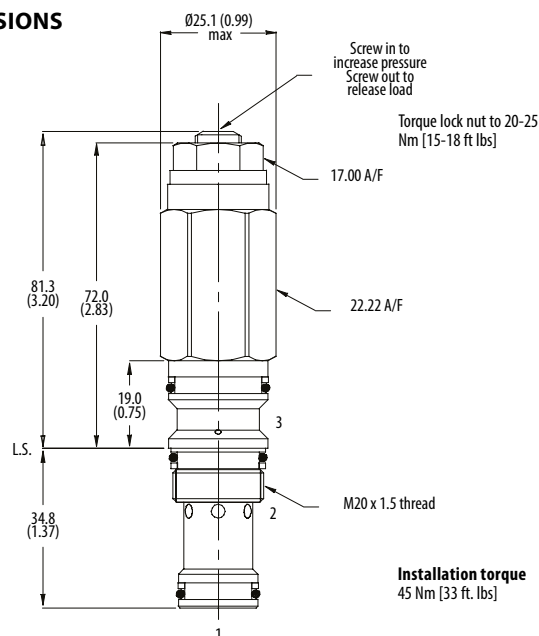

MODEL CODE

1SE30 - F - 35 - S - 5 - 210

Adjustment Option

F - External
G - Tamper resistant
N - Non-adjustable option, contact technical support

Pressure Range

Code	Pilot Ratio 2		Pilot Ratio 5		Pilot Ratio 10	
	Bar	Psi	Bar	Psi	Bar	Psi
20	70-225	[1015-3260]	70-225	[1015-3260]	70-225	[1015-3260]
Standard setting	100	[1450]	100	[1450]	100	[1450]
35	70-350	[1015-5000]	70-350	[1015-5000]	[120-350]	[1300-5000]
Standard setting	210	[3000]	210	[3000]	[210]	[3000]

Note: Std setting made at 4.5 l/min

Pressure Setting

Code Pressure setting in bar (10 bar increments within specified Pressure Range)
XXX Standard setting (see Pressure Range for value)
 Example:

Pilot Ratio

2 - 2.5:1
5 - 5:1
10 - 10:1

Code	Bar	Psi
210	210	[3000]

Seal Option

Code	Seal kit
S -Buna-N	SK1079
SV -Viton	SK1079V

Motion Control Valves

1SE90

Overcenter Valve, Standard, Direct Acting, Internal Drain, Port 3 Pilot

350 bar [5000 psi] • 90 l/min [24 US gpm]

DESCRIPTION AND OPERATION

This is a direct acting overcenter valve, which is a pilot assisted relief with a free flow check. With the relief valve set at approximately 1.3 times the maximum load induced pressure, the valve will prevent flow from port 1 to 2. When pilot pressure is applied to port 3, the valve will meter the flow from port 1 to 2, compensating for any change in pilot pressure due to over-running or unstable loads. Free flow takes place from port 2 to port 1 through the check portion of the valve. These valves are ideal in most applications bringing stability, load holding, and hose failure protection when the valve is mounted onto or into the actuator. The spring chamber is connected to the valve port 2, so any back pressure will increase the pilot pressure required to keep the valve open and the pressure at which the valve will open as a relief valve.

SCHEMATIC

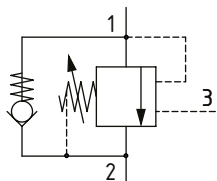

DIMENSIONS

mm [in]

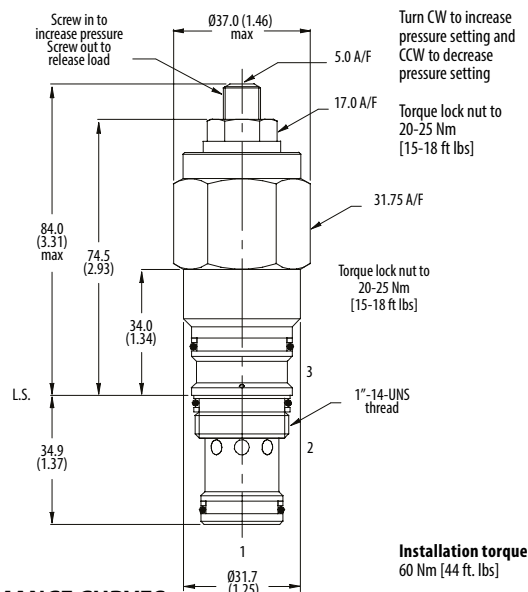

Installation torque
60 Nm [44 ft. lbs]

PERFORMANCE DATA

Rated pressure	350 bar [5000 psi]
Rated flow	90 l/min [24 US gpm]
Max total relief pressure	350 bar [5000 psi]
Max recommended load pressure at max setting	270 bar [3900 psi]
Pilot Ratio	4:1, 8:1
Leakage	0.3 ml/min nominal [5 drops/min]
Weight	0.42 kg [0.92 lb]
Cavity	A20092-T2A

PERFORMANCE CURVES

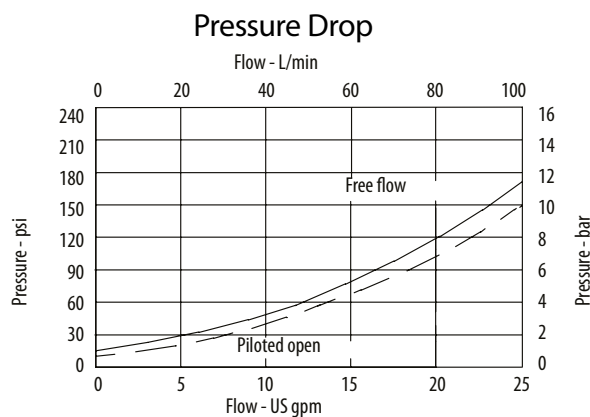

MODEL CODE

1SE90 - F - 35 - S - 4 - 210

Adjustment Option

F - External
G - Tamper resistant
N - Non-adjustable option, contact technical support

Pressure Range

Code	Bar	Psi
20	70-225	[1015-3260]
Standard Setting	100	[1450]
35	200-350	[2900-5000]
Standard Setting	210	[3000]

Std setting made at 4.5 l/min

Seal Option

Code	Seal kit
S -Buna-N	SK1093
SV -Viton	SK1093V

Pressure Setting

Code Pressure setting in bar (10 bar increments within specified Pressure Range)
XXX-Standard setting (see Pressure Range for value)
Example:

Code	Bar	Psi
210	210	[3000]

Pilot Ratio

4 - 4:1
8 - 8:1

Motion Control Valves

1SE140

Overcenter Valve, Standard, Direct Acting, Internal Drain, Port 3 Pilot

420 bar [6100 psi] • 140 l/min [37 US gpm]

DESCRIPTION AND OPERATION

This is a direct acting overcenter valve, which is a pilot assisted relief with a free flow check. With the relief valve set at approximately 1.3 times the maximum load induced pressure, the valve will prevent flow from port 1 to 2. When pilot pressure is applied to port 3, the valve will meter the flow from port 1 to 2, compensating for any change in pilot pressure due to over-running or unstable loads. Free flow takes place from port 2 to port 1 through the check portion of the valve. These valves are ideal in most applications bringing stability, load holding, and hose failure protection when the valve is mounted onto or into the actuator. The spring chamber is connected to the valve port 2, so any back pressure will increase the pilot pressure required to keep the valve open and the pressure at which the valve will open as a relief valve.

SCHEMATIC

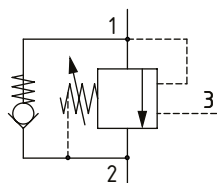

DIMENSIONS

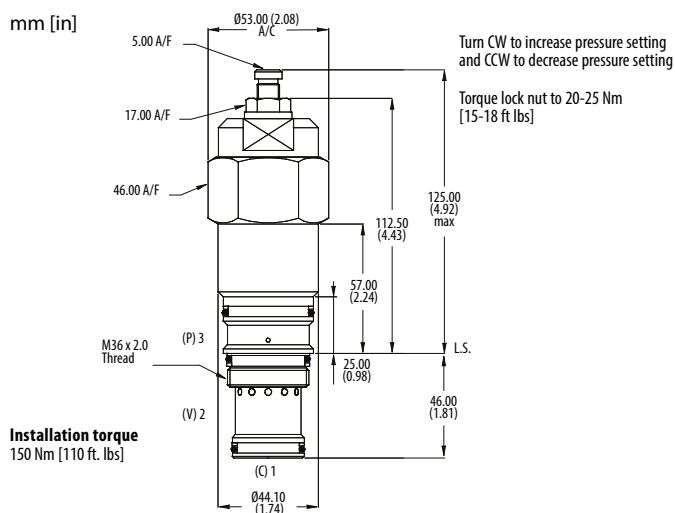

PERFORMANCE DATA

Rated pressure	420 bar [6100 psi]
Rated flow	140 l/min [37 US gpm]
Max total relief pressure	420 bar [6100 psi]
Max recommended load pressure at max setting	340 bar [4900 psi]
Pilot Ratio	4:1, 6:1
Leakage	0.3 ml/min nominal [5 drops/min]
Weight	1.2 kg [2.5 lb]
Cavity	A20094-T17A

PERFORMANCE CURVES

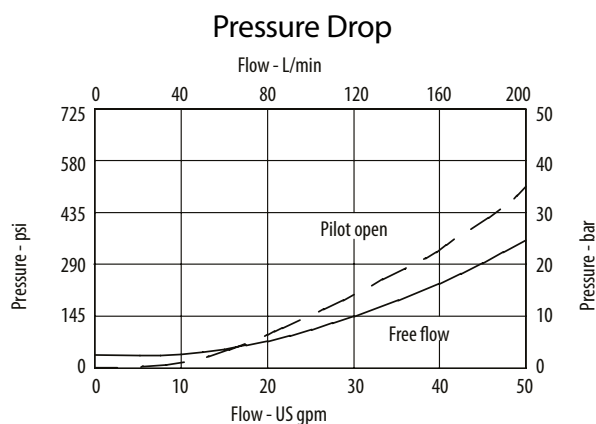

MODEL CODE

1SE140 - F - 40 - S - 4 - 210

Adjustment Option

F - External

Pressure Range

Code	Bar	Psi
20	140-250	[2000-3600]
Standard Setting	190	[2750]
30	220-330	[3200-4800]
Standard Setting	270	[3900]
40	310-420	[4500-6100]
Standard Setting	370	[5400]

Std setting made at 4.5 l/min

Pressure Setting

Code - Pressure setting in bar (10 bar increments within specified Pressure Range)
XXX - Standard setting (see Pressure Range for value)
Example:

Code	Bar	Psi
210	210	[3000]

Pilot Ratio

4 - 4:1
6 - 6:1

Seal Option

Code	Seal kit
S-Buna-N	SK1116
SV-Viton	SK1116V

Motion Control Valves

VCB 06-EN

Overcenter Valve, Standard, Differential Area, Internal Drain, Port 1 Pilot

350 bar [5000 psi] • 60 l/min [16 US gpm]

DESCRIPTION AND OPERATION

This is a differential area overcenter valve, which is a pilot assisted relief with a free flow check. With the relief valve set at around 1.3 times the maximum load induced pressure, the valve will prevent flow from taking place between ports 3 and 2. When pilot pressure is applied to port 1, the valve will meter the flow from port 3 to 2 compensating for any change in pilot pressure due to over-running or unstable loads. Free flow takes place from port 2 to port 3 through the check portion of the valve. These valves are ideal in most applications bringing stability, load holding, and hose failure protection when the valve is mounted onto or into the actuator. The spring chamber is connected to the valve port 2, so any back pressure will increase the pilot pressure required to keep the valve open and the pressure at which the valve will open as a relief valve.

Note: The VCB 06-EN is intended primarily for use in MVB10 modular valve assemblies. For other applications, consider valves with equivalent function, such as 1CE30.

SCHEMATIC

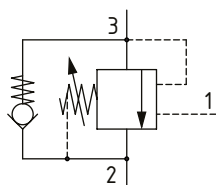

PERFORMANCE DATA

Rated pressure	350 bar [5000 psi]
Rated flow	60 l/min [16 US gpm]
Max total relief pressure	350 bar [5000 psi]
Max recommended load pressure at maximum setting	270 bar [3900 psi]
Pilot ratio	4:1, 7:1
Leakage	10 drops/min @ 70% of crack pressure
Weight	0.21 kg [0.47 lb]
Cavity	NCS06/3

DIMENSIONS

mm [in]

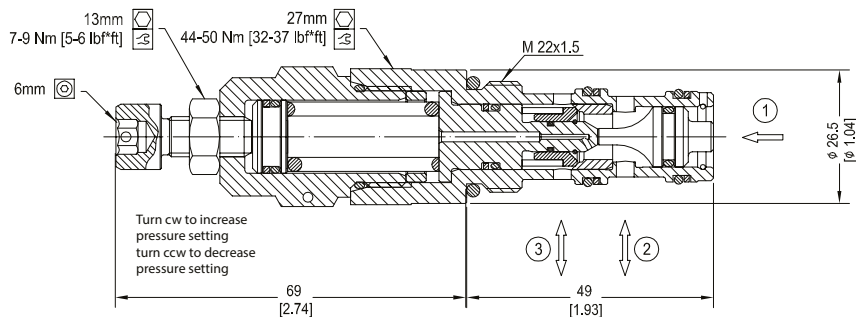

PERFORMANCE CURVES

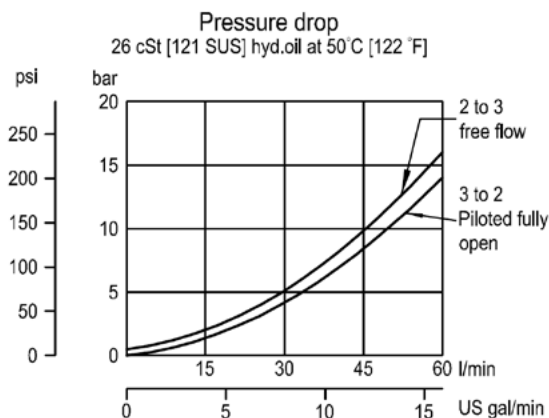

Motion Control Valves

VCB 06-EN

Overcenter Valve, Standard, Differential Area, Internal Drain, Port 1 Pilot

350 bar [5000 psi] • 60 l/min [16 US gpm]

■ SCHEMATIC

VCB 06-EN-DL (dual)

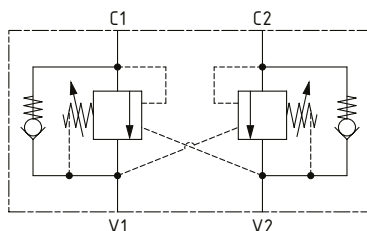

■ DIMENSIONS

mm [in]

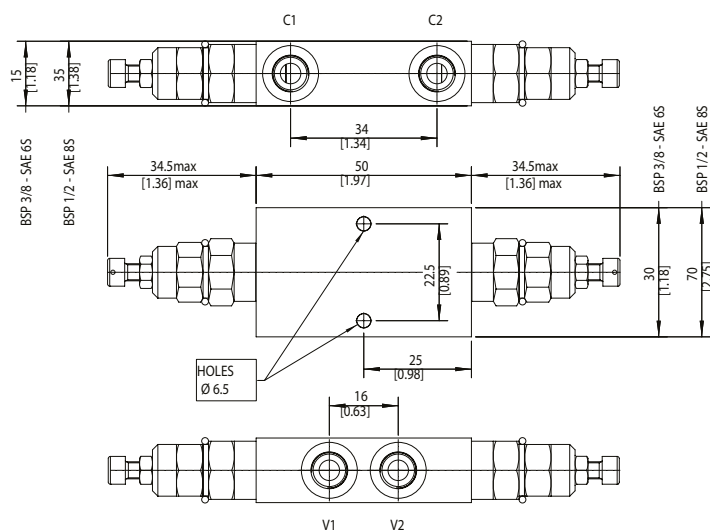

■ MODEL CODE

VCB06 - EN - 2 - A - 00 - B - 70

Pressure Range

Code	Bar	Psi
1	25-140	[360-2030]
2	70-210	[1015-3000]
3	105-350	[1520-5000]

Housing

Code	Ports & Material	Housing Number	Dual Housing Code	Dual Housing Number
00	No housing			
SE3B	AL, 3/8 BSP	NCS06-3-SE3B	DL3B	NCS06/3-DL3/8
SE4B	AL, 1/2 BSP	NCS06-3-SE4B	DL4B	NCS06/3-DL1/2
SE6S	AL, #6 SAE	NCS06-3-SE6S	DL6S	NCS06/3-DL6S
SE6S5	ST, #6SAE	NCS06-3-SE6S5		
SE8S	AL, #6 SAE	NCS06-3-SE8S	DL8S	NCS06/3-DL8S

* Aluminum bodies are to be used for pressures less than 210 bar [3000 psi].

* Additional housings available

Pilot Ratio

A - 7.1:1
B - 4.1:1

Pressure Setting

Code Pressure setting in bar (10 bar increments within specified Pressure Range)
XXX-No factory setting
Example:

Code	Bar	Psi
70	70	[1015]

Seal Option

Code	Seal kit
B-Buna-N	230000070
V-Viton	230000110

Motion Control Valves

1CER30

Overcenter Valve, Part Balanced, Direct Acting, Internal Drain, Port 3 Pilot

350 bar [5000 psi] • 30 l/min [8 US gpm]

DESCRIPTION AND OPERATION

This is a direct acting overcenter valve, which is a pilot assisted relief with a free flow check. With the relief valve set at around 1.3 times the maximum load induced pressure, the valve will prevent flow from taking place between ports 1 and 2. When pilot pressure is applied to port 3, the valve will meter the flow from port 1 to 2 compensating for any change in pilot pressure due to over-running or unstable loads. Free flow from port 2 to port 1 can take place freely through the check portion of the valve. These valves are ideal in most applications bringing stability, load holding, and hose failure protection when the valve is mounted onto or into the actuator. The spring chamber is connected to the valve port 2 so any back pressure will increase the pilot pressure required to keep the valve open. However, the balanced poppet design allows the relief valve to remain open provided the inlet pressure is higher than the setting. This is also available in a dual housing for bi-directional control.

SCHEMATIC

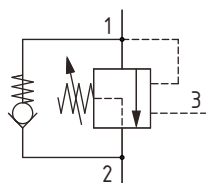

PERFORMANCE DATA

Rated pressure	350 bar [5000 psi]
Rated flow	30 l/min [8 US gpm]
Max total relief pressure	350 bar [5000 psi]
Max recommended load pressure at max setting	270 bar [3900 psi]
Pilot Ratio	2.5:1, 4:1
Leakage	0.3 ml/min nominal [5 drops/min]
Weight	0.15 kg [0.33 lb]
Cavity	A6610

DIMENSIONS

mm [in]

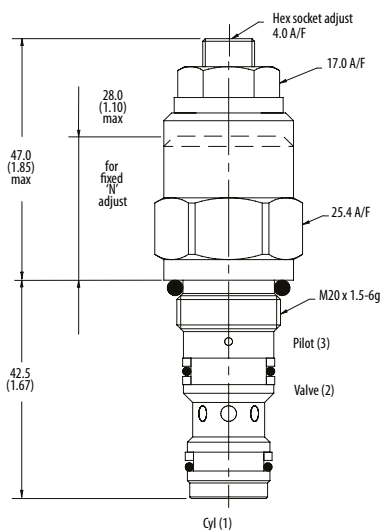

Turn CW to increase pressure setting and
CCW to decrease pressure setting.

Torque lock nut to 20-25 Nm
[15-18 ft lbs]

Installation torque
45 Nm [33 ft. lbs]

PERFORMANCE CURVES

Pressure Drop

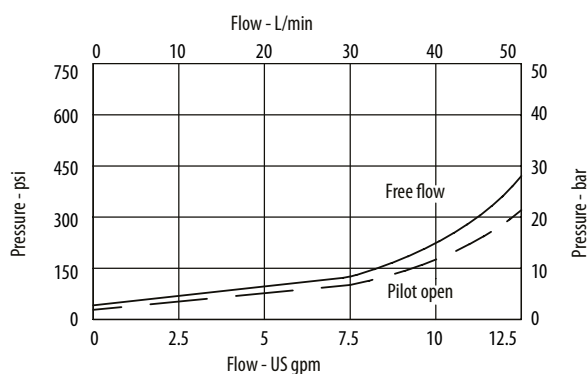

Motion Control Valves

1CER30

Overcenter Valve, Part Balanced, Direct Acting, Internal Drain, Port 3 Pilot

350 bar [5000 psi] • 30 l/min [8 US gpm]

■ SCHEMATIC

1CEER34 (dual)

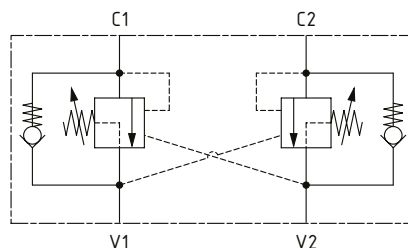

■ DIMENSIONS

mm [in]

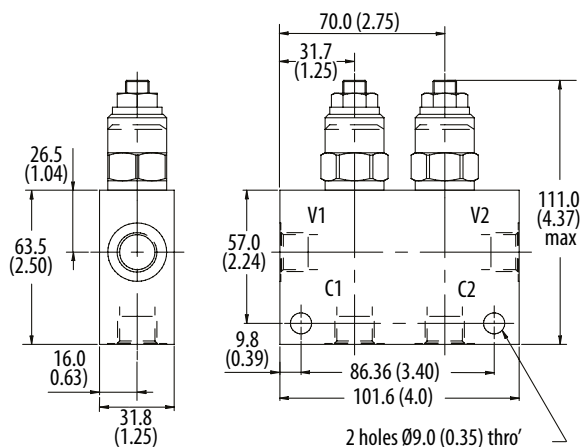

■ MODEL CODE

1CER35 - F - 3W - 35 - S - 4 - 377 - 210

Basic Code

1CER30 - No housing
1CER35 - Cartridge and housing
1CEER34 - Cartridges and dual housing

Adjustment Option

F - External
G - Tamper resistant
N - Non-adjustable option, contact technical support

Housing

Code	Ports	Aluminum single	Steel single	Aluminum dual	Steel dual
Omit	No Housing				
3W	3/8" BSP Valve & Cyl Port 1/4" BSP Pilot Port	B6743	B12823	B6836	B13803
6T	3/8" SAE Valve & Cyl Port 1/4" SAE Pilot Port	B10536		B10805	
8T	1/2" SAE Valve & Cyl Port 1/4" SAE Pilot Port	B7884	B11811	B30237	B11812

* Aluminum bodies are to be used for pressures less than 210 bar [3000 psi].

* Additional housings available

Pressure Setting

Code Pressure setting in bar (10 bar increments within specified Pressure Range)
XXX-Standard setting (see Pressure Range for value)
Example:

Code	Bar	Psi
210	210	[3000]

Housing Material

Omit - Aluminum/No housing
377 - Steel

Pilot Ratio

2 - 2.5:1
4 - 4:1

Seal Option

Code Seal kit

Buna-N SK395

SV-Viton SK395V

Pressure Range

Code	Bar	Psi
35	100-350	[1450-5000]
Standard Setting	210	[3000]

Std setting made at 4.5 l/min

Motion Control Valves

1CERH30

Overcenter Valve, Part Balanced, Direct Acting, Internal Drain, Port 3 Pilot

430 bar [6200 psi] • 30 l/min [8 US gpm]

DESCRIPTION AND OPERATION

This is a direct acting overcenter valve, which is a pilot assisted relief with a free flow check. With the relief valve set at around 1.3 times the maximum load induced pressure, the valve will prevent flow from taking place between ports 1 and 2. When pilot pressure is applied to port 3, the valve will meter the flow from port 1 to 2 compensating for any change in pilot pressure due to over-running or unstable loads. Free flow from port 2 to port 1 can take place freely through the check portion of the valve. These valves are ideal in most applications bringing stability, load holding, and hose failure protection when the valve is mounted onto or into the actuator. The spring chamber is connected to the valve port 2 so any back pressure will increase the pilot pressure required to keep the valve open. However, the balanced poppet design allows the relief valve to remain open provided the inlet pressure is higher than the setting. This is also available in a dual housing for bi-directional control.

SCHEMATIC

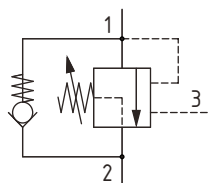

PERFORMANCE DATA

Rated pressure	430 bar [6200 psi]
Rated flow	30 l/min [8 US gpm]
Max total relief pressure	430 bar [6200 psi]
Max recommended load pressure at max setting	350 bar [5000 psi]
Pilot Ratio	3:1, 5:1
Leakage	5 drops/min @ 85% of Cracking
Weight	0.2 kg [0.55 lb]
Cavity	A6610

DIMENSIONS

mm [in]

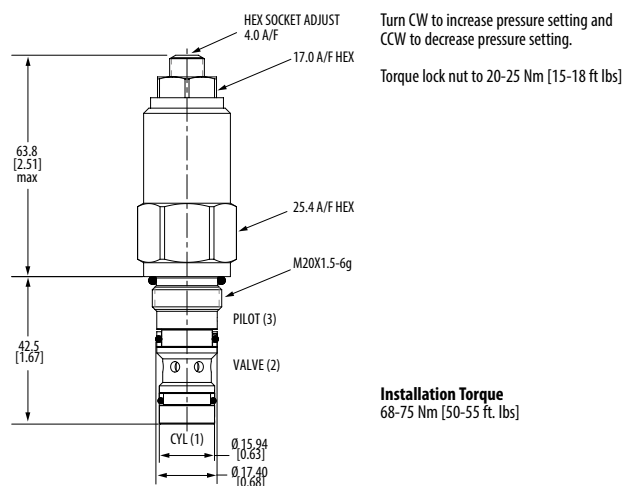

PERFORMANCE CURVES

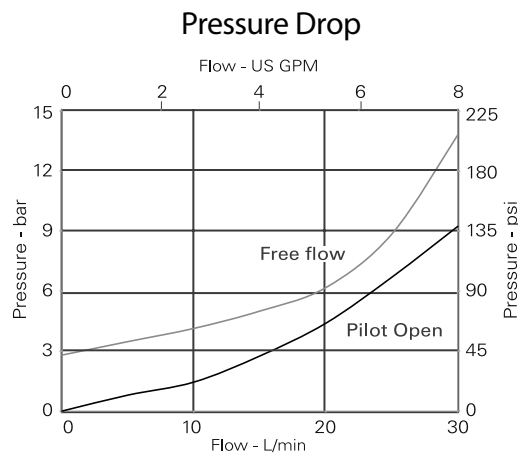

Motion Control Valves

1CERH30

Overcenter Valve, Part Balanced, Direct Acting, Internal Drain, Port 3 Pilot

430 bar [6200 psi] • 30 l/min [8 US gpm]

■ SCHEMATIC

1CEERH34 (dual)

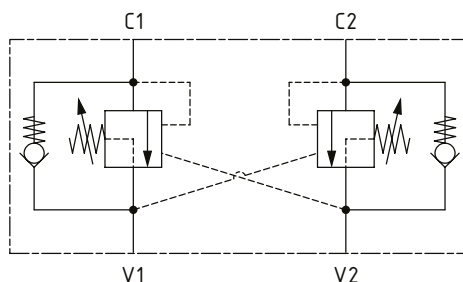

■ DIMENSIONS

mm [in]

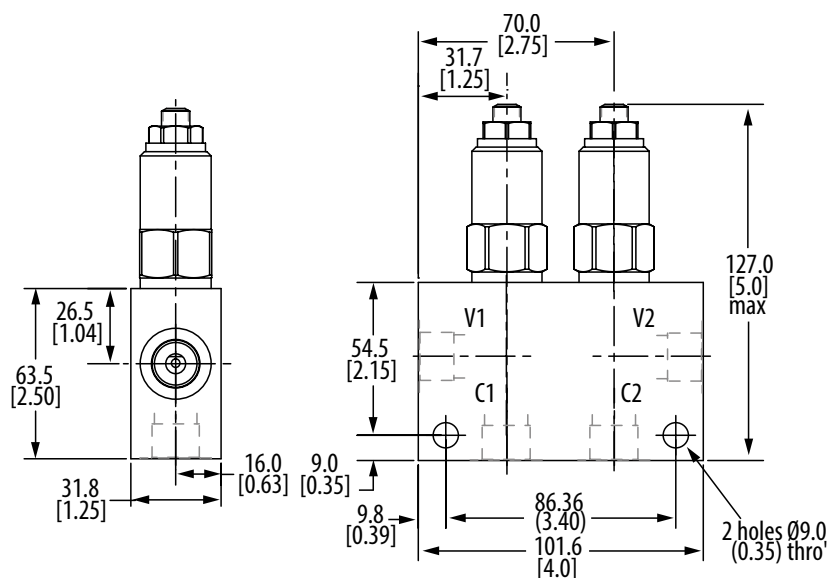

■ MODEL CODE

1CERH35 - F - 3W - 43 - S - 3 - 377 - 350

Basic Code

1CERH30 - No housing
1CERH35 - Cartridge and housing
1CEERH34 - Cartridges and dual housing

Adjustment Option

F - External

Housing

Code	Ports	Steel single	Steel dual
Omit	No housing		
3W	3/8" BSP Valve & Cyl Port 1/4" BSP Pilot Port	B12823	B13803
8T	1/2" SAE Valve & Cyl Port 1/4" SAE Pilot Port	B11811	B11812

Pressure Setting

Code Pressure setting in bar (10 bar increments within specified Pressure Range)
XXX - Standard setting (see Pressure Range for value)
Example:

Code	Bar	Psi
350	350	[5000]

Housing Material

Omit - No Housing
377 - Steel

Pilot Ratio

3 - 3:1
5 - 5:1

Seal Option

Code	Seal kit
S - Buna-N	9900925-000
SV - Viton	9900926-000

Pressure Range

Code	Bar	Psi
43	250-430	[3600-6200]
Standard Setting	350	[5000]

Std. setting made at 4.5 l/min

Motion Control Valves

1CER90

Overcenter Valve, Part Balanced, Direct Acting, Internal Drain, Port 3 Pilot

350 bar [5000 psi] • 90 l/min [24 US gpm]

DESCRIPTION AND OPERATION

This is a direct acting overcenter valve, which is a pilot assisted relief with a free flow check. With the relief valve set at around 1.3 times the maximum load induced pressure, the valve will prevent flow from taking place between ports 1 and 2. When pilot pressure is applied to port 3, the valve will meter the flow from port 1 to 2 compensating for any change in pilot pressure due to over-running or unstable loads. Free flow from port 2 to port 1 can take place freely through the check portion of the valve. These valves are ideal in most applications bringing stability, load holding, and hose failure protection when the valve is mounted onto or into the actuator. The spring chamber is connected to the valve port 2 so any back pressure will increase the pilot pressure required to keep the valve open. However, the balanced poppet design allows the relief valve to remain open provided the inlet pressure is higher than the setting. This is also available in a dual housing for bi-directional control.

SCHEMATIC

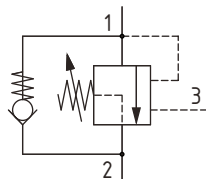

PERFORMANCE DATA

Rated pressure	350 bar [5000 psi]
Rated flow	90 l/min [24 US gpm]
Max total relief pressure	350 bar [5000 psi]
Max recommended load pressure at max setting	270 bar [3900 psi]
Pilot Ratio	4:1
Leakage	0.3 ml/min [5 drops/min]
Weight	0.29 kg [0.63 lb]
Cavity	A12336

DIMENSIONS

mm [in]

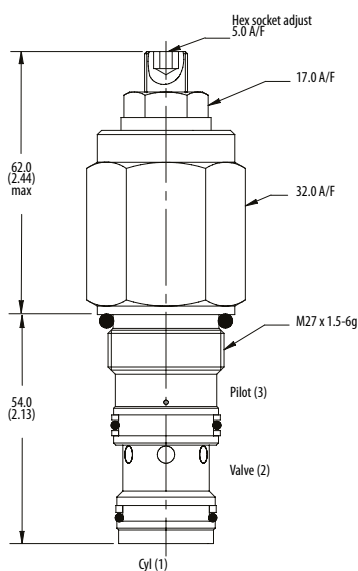

Turn CW to increase pressure setting and CCW to decrease pressure setting.

Torque lock nut to 20-25 Nm [15-18 ft lbs]

Installation Torque
60 Nm [44 ft. lbs]

PERFORMANCE CURVES

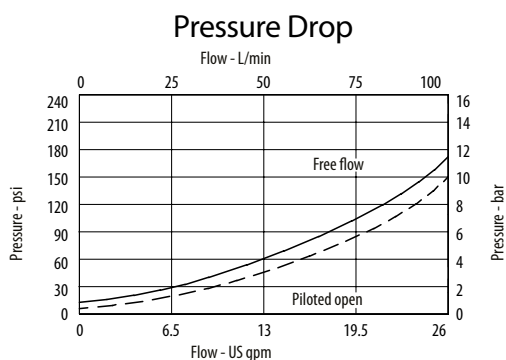

Motion Control Valves

1CER90

Overcenter Valve, Part Balanced, Direct Acting, Internal Drain, Port 3 Pilot

350 bar [5000 psi] • 90 l/min [24 US gpm]

■ SCHEMATIC

1CEER95 (dual)

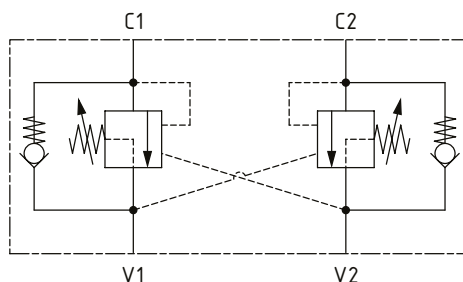

■ DIMENSIONS

mm [in]

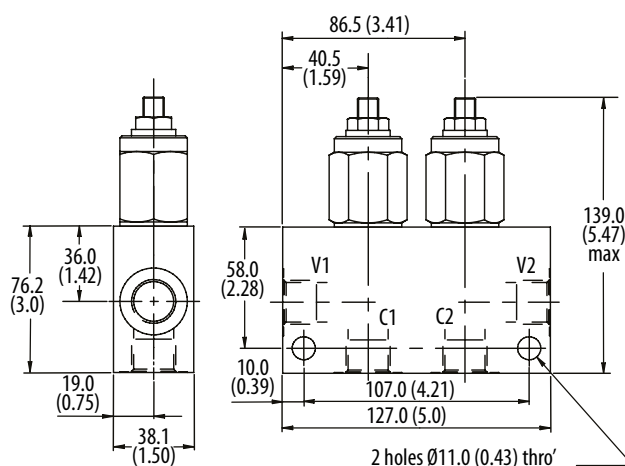

■ MODEL CODE

1CER95 - F - 4W - 35 - S - 4 - 377 - 210

Basic Code

1CER90 - No housing
1CER95 - Cartridge and housing
1CEER95 - Cartridges and dual housing

Adjustment Option

F - External
G - Tamper resistant
N - Non-adjustable option, contact technical support

Housing

Code	Ports	Aluminum single	Steel single	Aluminum dual	Steel dual
Omit	No housing				
4W	1/2" BSP Valve & Cyl Port 1/4" BSP Pilot Port	B13625	B13626	C13627	C13628
8T	1/2" SAE Valve & Cyl Port 1/4" SAE Pilot Port	B10806	B10922	C10807	C11561

* Aluminum bodies are to be used for pressures less than 210 bar [3000 psi].

* Additional housings available

Pressure Setting

Code Pressure setting in bar (10 bar increments within specified Pressure Range)

XXX - Standard setting (see Pressure Range for value)
Example:

Code	Bar	Psi
210	210	[3000]

Housing Material

Omit - Aluminum/No housing
377 - Steel

Pilot Ratio

4 - 4:1

Seal Option

Code	Seal kit
S-Buna-N	SK633
SV-Viton	SK633V

Pressure Range

Code	Bar	Psi
20	70-225	[1015-3260]
Standard Setting	100	[1450]
35	200-350	[2900-5000]
Standard Setting	210	[3000]

Std setting made at 4.5 l/min

Motion Control Valves

1CERH90

Overcenter Valve, Part Balanced, Direct Acting, Internal Drain, Port 3 Pilot

430 bar [6200 psi] • 90 l/min [24 US gpm]

DESCRIPTION AND OPERATION

This is a direct acting overcenter valve, which is a pilot assisted relief with a free flow check. With the relief valve set at around 1.3 times the maximum load induced pressure, the valve will prevent flow from taking place between ports 1 and 2. When pilot pressure is applied to port 3, the valve will meter the flow from port 1 to 2 compensating for any change in pilot pressure due to over-running or unstable loads. Free flow from port 2 to port 1 can take place freely through the check portion of the valve. These valves are ideal in most applications bringing stability, load holding, and hose failure protection when the valve is mounted onto or into the actuator. The spring chamber is connected to the valve port 2 so any back pressure will increase the pilot pressure required to keep the valve open. However, the balanced poppet design allows the relief valve to remain open provided the inlet pressure is higher than the setting. This is also available in a dual housing for bi-directional control.

SCHEMATIC

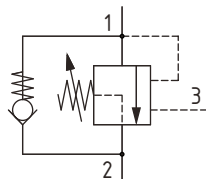

PERFORMANCE DATA

Rated pressure	430 bar [6200 psi]
Rated flow	90 l/min [24 US gpm]
Max total relief pressure	430 bar [6200 psi]
Max recommended load pressure at max setting	350 bar [5000 psi]
Pilot Ratio	4:1
Leakage	5 drops/min @ 85% of Cracking
Weight	0.6 kg [1.32 lb]
Cavity	A12336

DIMENSIONS

mm [in]

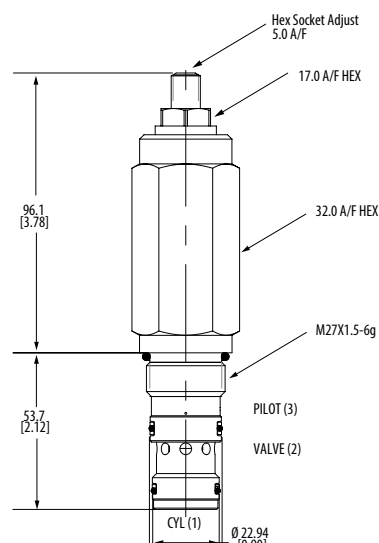

Turn CW to increase pressure setting and CCW to decrease pressure setting

Torque lock nut to 20-25 Nm [15-18 ft lbs]

Installation Torque
100-110 Nm [73-81 ft. lbs]

PERFORMANCE CURVES

Pressure Drop

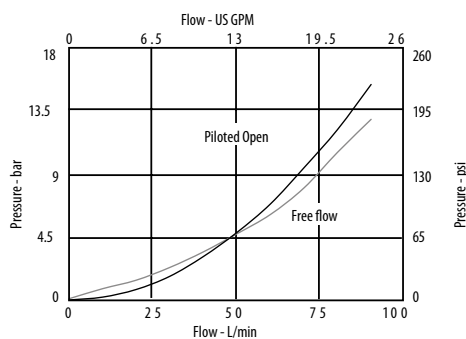

Motion Control Valves

1CERH90

Overcenter Valve, Part Balanced, Direct Acting, Internal Drain, Port 3 Pilot

430 bar [6200 psi] • 90 l/min [24 US gpm]

■ SCHEMATIC

1CEERH95 (dual)

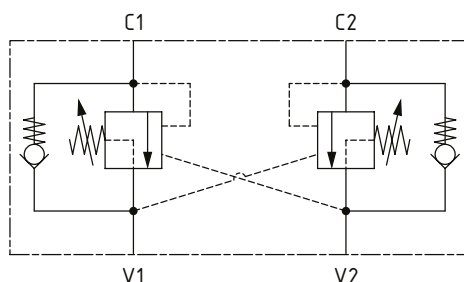

■ DIMENSIONS

mm [in]

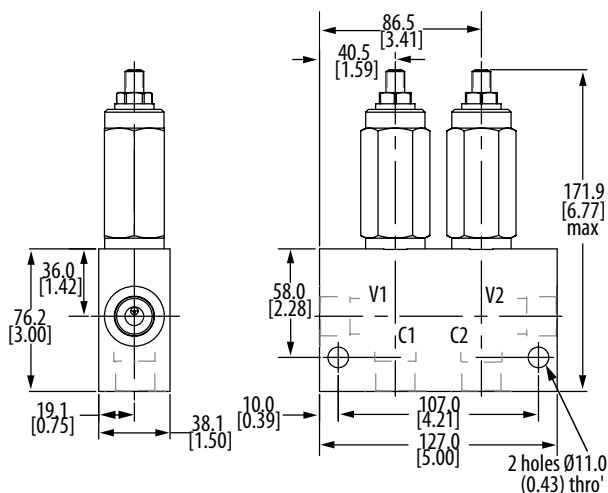

■ MODEL CODE

1CERH95 - F - 4W - 43 - S - 4 - 377 - 350

Basic Code

1CERH90 - No housing
1CERH95 - Cartridge and housing
1CEERH95 - Cartridges and dual housing

Adjustment Option

F - External

Housing

Code	Ports	Steel single	Steel dual
Omit	No housing		
4W	1/2" BSP Valve & Cyl Port 1/4" BSP Pilot Port	B13626	C13628
8T	1/2" SAE Valve & Cyl Port 1/4" SAE Pilot Port	B10922	C11561

* Aluminum bodies are to be used for pressures less than 210 bar [3000 psi].

Pressure Setting

Code Pressure setting in bar (10 bar increments within specified Pressure Range)

XXX-Standard setting (see Pressure Range for value)
Example:

Code	Bar	Psi
350	350	[5000]

Housing Material

Omit - No housing
377 - Steel

Pilot Ratio

4 - 4:1

Seal Option

Code	Seal kit
S-Buna-N	9900927-000
SV-Viton	9900928-000

Pressure Range

Code	Bar	Psi
43	275-430	[4000-6200]
Standard Setting	350	[5000]

Std. setting at 4.5 l/min

Motion Control Valves

1CER140

Overcenter Valve, Part Balanced, Direct Acting, Internal Drain, Port 3 Pilot

420 bar [6100 psi] • 140 l/min [37 US gpm]

DESCRIPTION AND OPERATION

This is a direct acting overcenter valve, which is a pilot assisted relief with a free flow check. With the relief valve set at around 1.3 times the maximum load induced pressure, the valve will prevent flow from taking place between ports 1 and 2. When pilot pressure is applied to port 3, the valve will meter the flow from port 1 to 2 compensating for any change in pilot pressure due to over-running or unstable loads. Free flow from port 2 to port 1 can take place freely through the check portion of the valve. These valves are ideal in most applications bringing stability, load holding, and hose failure protection when the valve is mounted onto or into the actuator. The spring chamber is connected to the valve port 2 so any back pressure will increase the pilot pressure required to keep the valve open. However, the balanced poppet design allows the relief valve to remain open provided the inlet pressure is higher than the setting. This is also available in a dual housing for bi-directional control.

SCHEMATIC

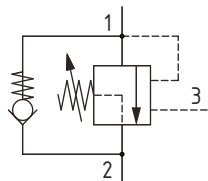

PERFORMANCE DATA

Rated pressure	420 bar [6100 psi]
Rated flow	140 l/min [37 US gpm]
Max total relief pressure	420 bar [6100 psi]
Max recommended load pressure at max setting	340 bar [4900 psi]
Pilot Ratio	4:1, 6:1
Leakage	0.3 ml/min nominal [5 drops/min]
Weight	1.2 kg [2.6 lb]
Cavity	A20081

DIMENSIONS

mm [in]

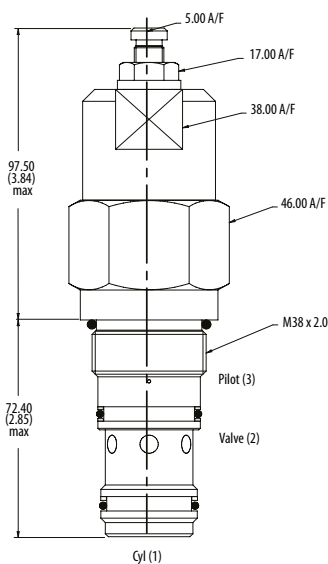

Turn CW to increase pressure setting and CCW to decrease pressure setting

Torque lock nut to 20-25 Nm [15-18 ft lbs]

Installation Torque
150 Nm [110 ft. lbs]

PERFORMANCE CURVES

Pressure Drop

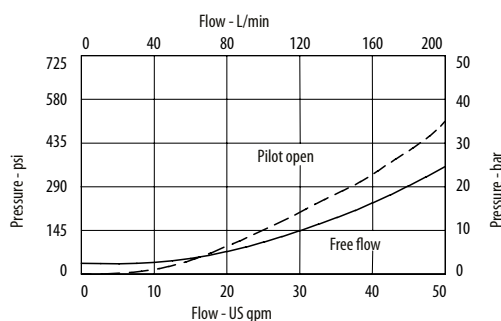

Motion Control Valves

1CER140

Overcenter Valve, Part Balanced, Direct Acting, Internal Drain, Port 3 Pilot

420 bar [6100 psi] • 140 l/min [37 US gpm]

■ SCHEMATIC

1CEER145 (dual)

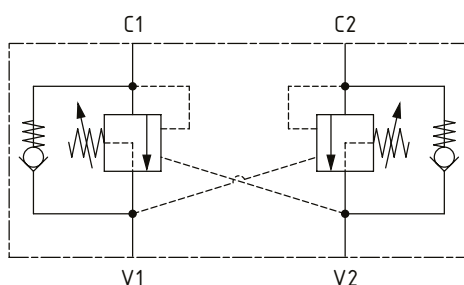

■ DIMENSIONS

mm [in]

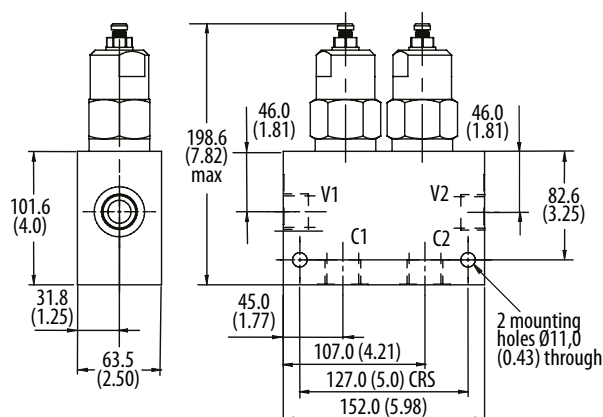

■ MODEL CODE

1CER145 - F - 6W - 20 - S - 4 - 377 - 210

Basic Code

1CER140 - No housing
1CER145 - Cartridge and housing
1CEER145 - Cartridges and dual housing

Adjustment Option

F - External

Housing

Code	Ports	Aluminum single	Steel single	Aluminum dual	Steel dual
Omit	No housing				
6W	3/4" BSP Valve & Cyl Port. 1/4" BSP Pilot Port	B20105	B20106		
8W	1" BSP Valve & Cyl Port. 1/4" BSP Pilot Port	B20107	B20108	C20285	C20287
12T	3/4" SAE Valve & Cyl Port. 1/4" SAE Pilot Port	B11952	B11953		
16T	1" SAE Valve & Cyl Port. 1/4" SAE Pilot Port	B11946	B11947	C30105	C30106

* Aluminum bodies are to be used for pressures less than 210 bar [3000 psi].

* Additional housings available

Pressure Setting

Code Pressure setting in bar (10 bar increments within specified Pressure Range)
XXX-Standard setting (see Pressure Range for value)
Example:

Code	Bar	Psi
210	210	[3000]

Housing Material

Omit - Aluminum/No housing
377 - Steel

Pilot Ratio

4 - 4:1
6 - 6:1

Seal Option

Code Seal kit

S-Buna-N SK1108

SV-Viton SK1108V

Pressure Range

Code	Bar	Psi
20	140-250	[2000-3600]
Standard Setting	190	[2750]
30	220-330	[2200-4800]
Standard Setting	270	[3900]
40	310-420	[4500-6100]
Standard Setting	370	[5400]

Std setting made at 4.5 l/min

Motion Control Valves

1SER30

Overcenter Valve, Part Balanced, Direct Acting, Internal Drain, Port 3 Pilot

350 bar [5000 psi] • 30 l/min [8 US gpm]

DESCRIPTION AND OPERATION

This is a direct acting overcenter valve, which is a pilot assisted relief with a free flow check. With the relief valve set at around 1.3 times the maximum load induced pressure, the valve will prevent flow from taking place between ports 1 and 2. When pilot pressure is applied to port 3, the valve will meter the flow from port 1 to 2 compensating for any change in pilot pressure due to over-running or unstable loads. Free flow from port 2 to port 1 can take place freely through the check portion of the valve. These valves are ideal in most applications bringing stability, load holding, and hose failure protection when the valve is mounted onto or into the actuator. The spring chamber is connected to the valve port 2 so any back pressure will increase the pilot pressure required to keep the valve open. However, the balanced poppet design allows the relief valve to remain open provided the inlet pressure is higher than the setting.

SCHEMATIC

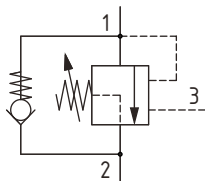

DIMENSIONS

mm [in]

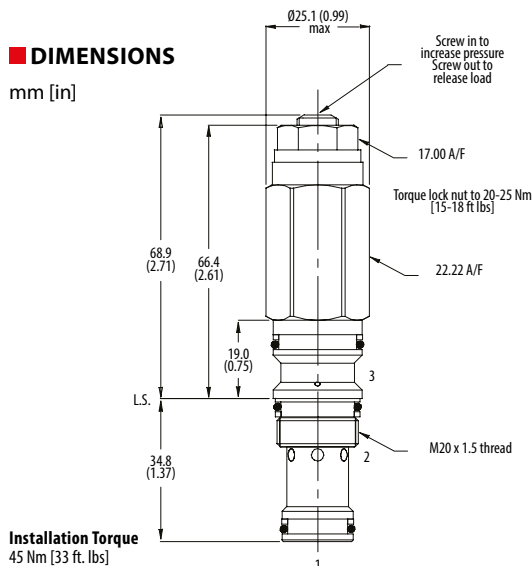

PERFORMANCE DATA

Rated pressure	350 bar [5000 psi]
Rated flow	30 l/min [8 US gpm]
Max total relief pressure	350 bar [5000 psi]
Max recommended load pressure at max setting	270 bar [3900 psi]
Pilot Ratio	4:1
Leakage	0.3 ml/min nominal [5 drops/min]
Weight	0.15 kg [0.33 lb]
Cavity	A20090-T11A

PERFORMANCE CURVES

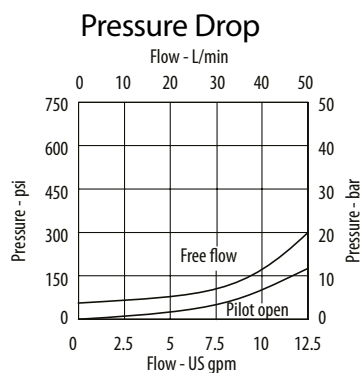

MODEL CODE

1SER30 - F - 35 - S - 4 - 210

Adjustment Option

F - External
G - Tamper resistant

Pressure Range

Code	Bar	Psi
35	75-350	[1090-5000]
Standard Setting	210	[3000]

Std setting made at 4.5 l/min

Pressure Setting

Code Pressure setting in bar (10 bar increments within specified Pressure Range)

XXX-Standard setting (see Pressure Range for value)

Example:

Code	Bar	Psi
210	210	[3000]

Pilot Ratio

4 - 4:1

Seal Option

Code	Seal kit
S-Buna-N	SK1079
SV-Viton	SK1079V

Motion Control Valves

1SER90

Overcenter Valve, Part Balanced, Direct Acting, Internal Drain, Port 3 Pilot

350 bar [5000 psi] • 90 l/min [24 US gpm]

DESCRIPTION AND OPERATION

This is a direct acting overcenter valve, which is a pilot assisted relief with a free flow check. With the relief valve set at around 1.3 times the maximum load induced pressure, the valve will prevent flow from taking place between ports 1 and 2. When pilot pressure is applied to port 3, the valve will meter the flow from port 1 to 2 compensating for any change in pilot pressure due to over-running or unstable loads. Free flow from port 2 to port 1 can take place freely through the check portion of the valve. These valves are ideal in most applications bringing stability, load holding, and hose failure protection when the valve is mounted onto or into the actuator. The spring chamber is connected to the valve port 2 so any back pressure will increase the pilot pressure required to keep the valve open. However, the balanced poppet design allows the relief valve to remain open provided the inlet pressure is higher than the setting.

SCHEMATIC

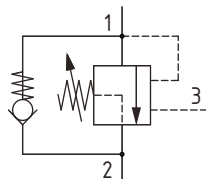

DIMENSIONS

mm [in]

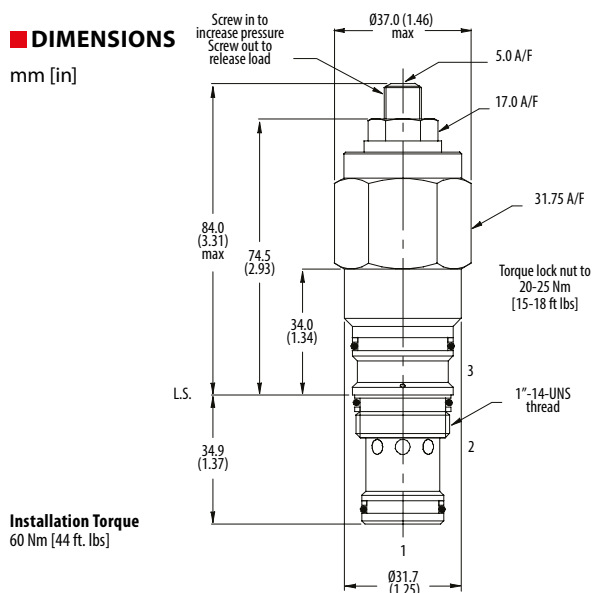

Installation Torque
60 Nm [44 ft. lbs]

PERFORMANCE CURVES

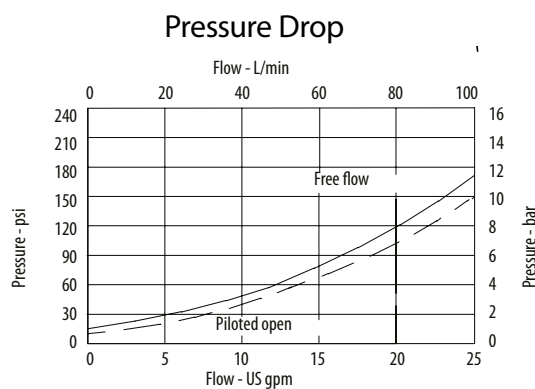

PERFORMANCE DATA

Rated pressure	350 bar [5000 psi]
Rated flow	90 l/min [24 US gpm]
Max total relief pressure	350 bar [5000 psi]
Max recommended load pressure at max setting	270 bar [3900 psi]
Pilot Ratio	4:1
Leakage	0.3 ml/min nominal [5 drops/min]
Weight	0.42 kg [0.92 lb]
Cavity	A20092-T2A

MODEL CODE

1SER90 - F - 35 - S - 4 - 210

Adjustment Option

F - External
G - Tamper resistant

Pressure Range

Code	Bar	Psi
20	75-225	[1090-3260]
Standard Setting	100	[1450]
35	200-350	[2900-5000]
Standard Setting	210	[3000]

Std setting made at 4.5 l/min

Pressure Setting

Code Pressure setting in bar (10 bar increments within specified Pressure Range)

XXX-Standard setting (see Pressure Range for value)

Example:

Code	Bar	Psi
210	210	[3000]

Pilot Ratio

4 - 4:1

Seal Option

Code	Seal kit
S-Buna-N	SK1093
SV-Viton	SK1093V

Motion Control Valves

1SER140

Overcenter Valve, Part Balanced, Direct Acting, Internal Drain, Port 3 Pilot

420 bar [6100 psi] • 140 l/min [37 US gpm]

DESCRIPTION AND OPERATION

This is a direct acting overcenter valve, which is a pilot assisted relief with a free flow check. With the relief valve set at around 1.3 times the maximum load induced pressure, the valve will prevent flow from taking place between ports 1 and 2. When pilot pressure is applied to port 3, the valve will meter the flow from port 1 to 2 compensating for any change in pilot pressure due to over-running or unstable loads. Free flow from port 2 to port 1 can take place freely through the check portion of the valve. These valves are ideal in most applications bringing stability, load holding, and hose failure protection when the valve is mounted onto or into the actuator. The spring chamber is connected to the valve port 2 so any back pressure will increase the pilot pressure required to keep the valve open. However, the balanced poppet design allows the relief valve to remain open provided the inlet pressure is higher than the setting.

SCHEMATIC

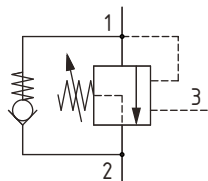

DIMENSIONS

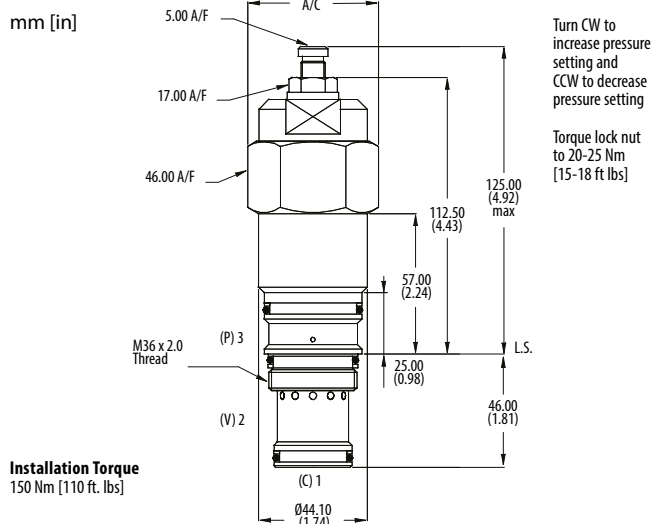

PERFORMANCE DATA

Rated pressure	420 bar [6100 psi]
Rated flow	140 l/min [37 US gpm]
Max total relief pressure	420 bar [6100 psi]
Max recommended load pressure at max setting	340 bar [4900 psi]
Pilot Ratio	4:1, 6:1
Leakage	0.3 ml/min nominal [5 drops/min]
Weight	1.2 kg [2.5 lb]
Cavity	A20094-T17A

PERFORMANCE CURVES

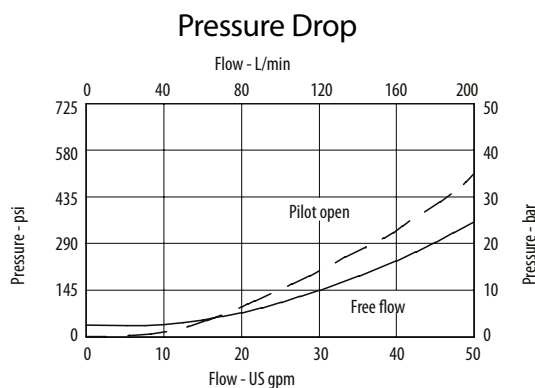

MODEL CODE

1SER140 - F - 40 - S - 4 - 350

Adjustment Option

F - External

Pressure Range

Code	Bar	Psi
20	140-250	[2030-3600]
Standard Setting	190	[2750]
30	220-330	[3200-4800]
Standard Setting	270	[3900]
40	310-420	[4500-6100]
Standard Setting	370	[5400]

Std setting made at 4.5 l/min

Pressure Setting

Code Pressure setting in bar (10 bar increments within specified Pressure Range)

XXX-Standard setting (see Pressure Range for value)

Example:

Code	Bar	Psi
350	350	[5000]

Pilot Ratio

4 - 4:1

6 - 6:1

Seal Option

Code	Seal kits
S-Buna-N	SK1116
SV-Viton	SK1116V

Motion Control Valves

1CEB30

Overcenter Valve, Fully Balanced, Direct Acting, Atmospheric Vent, Port 3 Pilot

350 bar [5000 psi] • 30 l/min [8 US gpm]

DESCRIPTION AND OPERATION

This is a direct acting overcenter valve, which is a pilot assisted relief valve with a free flow check. With the relief valve set at around 1.3 times the maximum load induced pressure, the valve will prevent flow from taking place between ports 1 and 2. When pilot pressure is applied to port 3 the valve will meter the flow from port 1 to 2 compensating for any change in pilot pressure due to over-running or unstable loads. Free flow from port 2 to port 1 can take place freely through the check portion of the valve. These valves are ideal in most applications bringing stability, load holding, and hose failure protection when the valve is mounted onto or into the actuator. The spring chamber is connected to atmosphere, so any back pressure will have no effect on the opening of the valve. Over time, there may be leakage past the seals to atmosphere. For valves with a separate drain port, reference the 1CEBD products. This is also available in a dual housing for bi-directional control.

SCHEMATIC

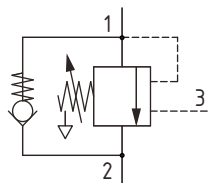

PERFORMANCE DATA

Rated pressure	350 bar [5000 psi]
Rated flow	30 l/min [8 US gpm]
Max total relief pressure	350 bar [5000 psi]
Max recommended load pressure at max setting	270 bar [3900 psi]
Pilot Ratio	5:1
Leakage	0.3 ml/min nominal [5 drops/min]
Weight	0.14 kg [0.30 lb]
Cavity	A6610

DIMENSIONS

mm [in]

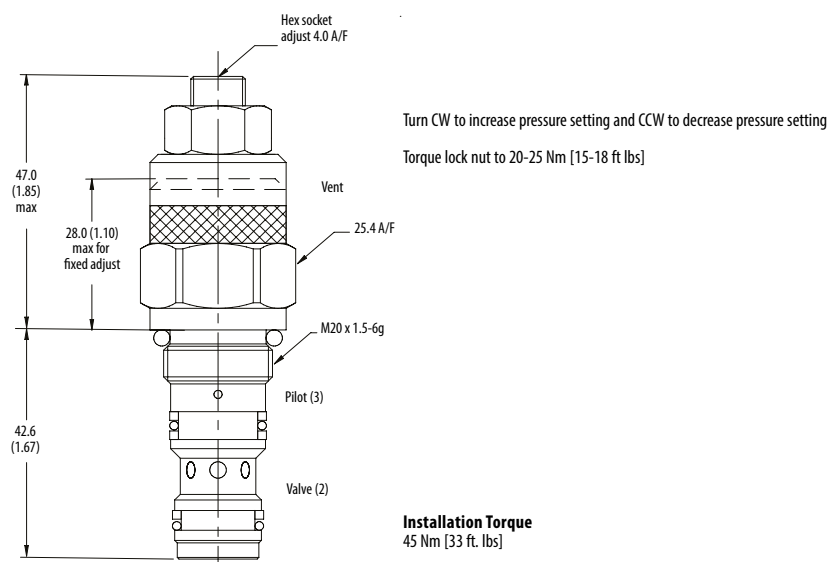

PERFORMANCE CURVES

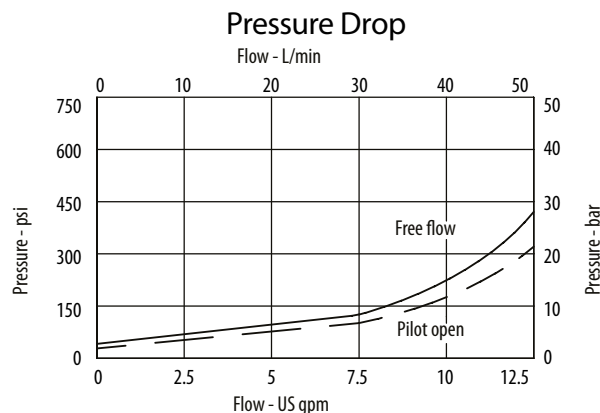

Motion Control Valves

1CEB30

Overcenter Valve, Fully Balanced, Direct Acting, Atmospheric Vent, Port 3 Pilot

350 bar [5000 psi] • 30 l/min [8 US gpm]

■ SCHEMATIC

1CEEB34 (dual)

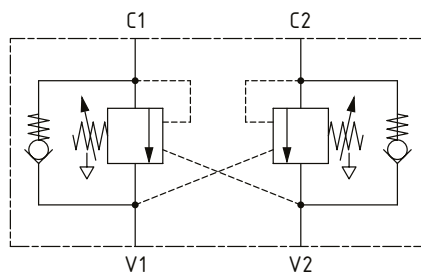

■ DIMENSIONS

mm [in]

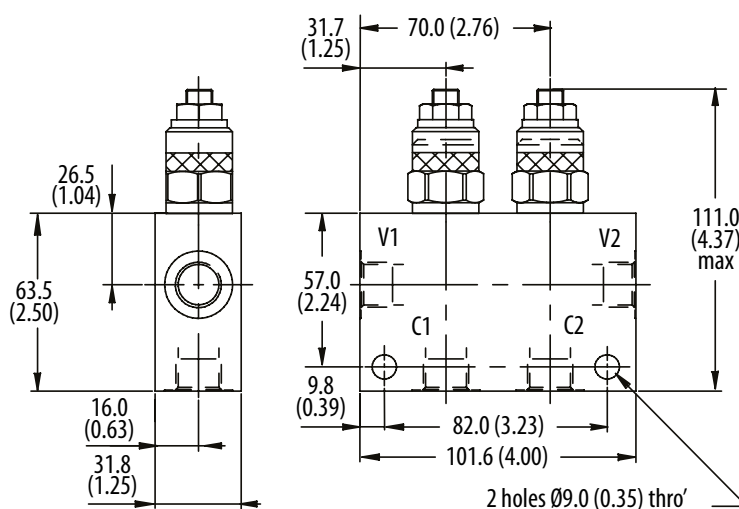

■ MODEL CODE

1CEB30 - F - 3W - 35 - S - 5 - 377 - 210

Basic Code

1CEB30 - No housing
1CEB35 - Cartridge and housing
1CEEB34 - Cartridges and dual housing

Adjustment Option

F - External
N - Non-adjustable option, contact technical support.

Housing

Code	Ports	Aluminum single	Steel single	Aluminum dual	Steel dual
Omit	No housing				
3W	3/8" BSP Valve & Cyl Port 1/4" BSP Pilot Port	B6743	B12823	B6836	B13803
6T	3/8" SAE Valve & Cyl Port 1/4" SAE Pilot Port	B10536		B10805	
8T	1/2" SAE Valve & Cyl Port 1/4" SAE Pilot Port	B7884	B11811	B30237	B11812

* Aluminum bodies are to be used for pressures less than 210 bar [3000 psi].

* Additional housings available

Pressure Setting

Code Pressure setting in bar (10 bar increments within specified Pressure Range)

XXX-Standard setting (see Pressure Range for value)
Example:

Code	Bar	Psi
210	210	[3000]

Housing Material

Omit - Aluminum/No housing
377 - Steel

Pilot Ratio

5 - 5:1

Seal Option

Code	Seal kit
S-Buna-N	SK395
SV-Viton	SK395V

Pressure Range

Code	Bar	Psi
35	100-350	[1450-5000]
Standard Setting	210	[3000]

Std setting made at 4.5 l/min

Motion Control Valves

1CEB90

Overcenter Valve, Fully Balanced, Direct Acting, Atmospheric Vent, Port 3 Pilot

350 bar [5000 psi] • 90 l/min [24 US gpm]

DESCRIPTION AND OPERATION

This is a direct acting overcenter valve, which is a pilot assisted relief valve with a free flow check. With the relief valve set at around 1.3 times the maximum load induced pressure, the valve will prevent flow from taking place between ports 1 and 2. When pilot pressure is applied to port 3 the valve will meter the flow from port 1 to 2 compensating for any change in pilot pressure due to over-running or unstable loads. Free flow from port 2 to port 1 can take place freely through the check portion of the valve. These valves are ideal in most applications bringing stability, load holding, and hose failure protection when the valve is mounted onto or into the actuator. The spring chamber is connected to atmosphere, so any back pressure will have no effect on the opening of the valve. Over time, there may be leakage past the seals to atmosphere. For valves with a separate drain port, reference the 1CEBD products. This is also available in a dual housing for bi-directional control.

SCHEMATIC

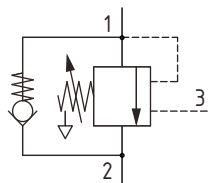

PERFORMANCE DATA

Rated pressure	350 bar [5000 psi]
Rated flow	90 l/min [24 US gpm]
Max total relief pressure	350 bar [5000 psi]
Max recommended load pressure at max setting	270 bar [3900 psi]
Pilot Ratio	4:1
Leakage	0.3 ml/min [5 drops/min]
Weight	0.29 kg [0.63 lb]
Cavity	A12336

DIMENSIONS

mm [in]

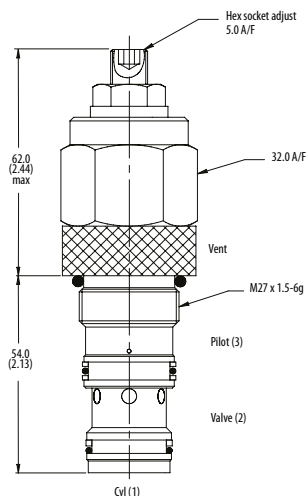

Turn CW to increase pressure setting and CCW to decrease pressure setting
Torque lock nut to 20-25 Nm [15-18 ft lbs]

Installation Torque
60 Nm [44 ft. lbs]

PERFORMANCE CURVES

Pressure Drop

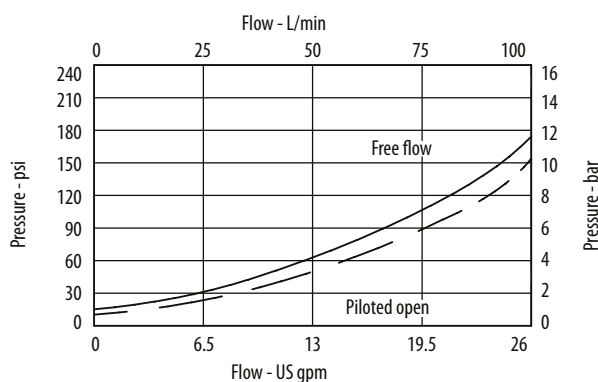

Motion Control Valves

1CEB90

Overcenter Valve, Fully Balanced, Direct Acting, Atmospheric Vent, Port 3 Pilot

350 bar [5000 psi] • 90 l/min [24 US gpm]

■ SCHEMATIC

1CEEB95 (dual)

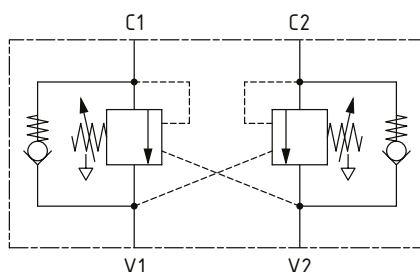

■ DIMENSIONS

mm [in]

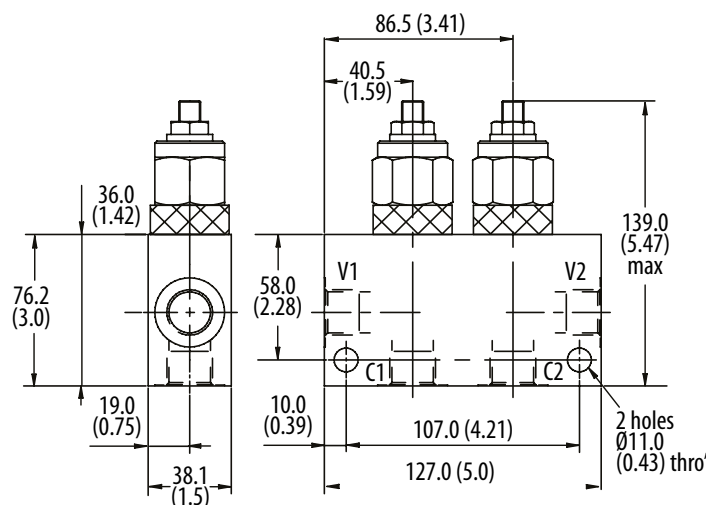

■ MODEL CODE

1CEB90 - F - 4W - 35 - S - 4 - 377 - 210

Basic Code

1CEB90 - No housing
1CEB95 - Cartridge and housing
1CEEB95 - Cartridges and dual housing

Adjustment Option

F - External
G - Tamper resistant
N - Non-adjustable option, contact technical support.

Housing

Code	Ports	Aluminum single	Steel single	Aluminum dual	Steel dual
Omit	No housing				
4W	1/2" BSP Valve & Cyl Port 1/4" BSP Pilot Port	B13625	B13626	C13627	C13628
8T	1/2" SAE Valve & Cyl Port 1/4" SAE Pilot Port	B10806	B10922	C10807	C11561

* Aluminum bodies are to be used for pressures less than 210 bar [3000 psi].

* Additional housings available

Pressure Setting

Code - Pressure setting in bar (10 bar increments within specified Pressure Range)
XXX - Standard setting (see Pressure Range for value)
Example:

Code	Bar	Psi
210	210	[3000]

Housing Material

Omit - Aluminum/No housing
377 - Steel

Pilot Ratio

4 - 4:1

Seal Option

Code	Seal kit
S	Buna-N SK634
SV	Viton SK634V

Pressure Range

Code	Bar	Psi
20	70-225	[1015-3260]
Standard Setting	100	[1450]
35	200-350	[2900-5000]
Standard Setting	210	[3000]

Std setting made at 4.5 l/min

Motion Control Valves

1CEB120

Overcenter Valve, Fully Balanced, Differential Area, Atmospheric Vent, Port 3 Pilot

350 bar [5000 psi] • 120 l/min [32 US gpm]

DESCRIPTION AND OPERATION

This is a differential area overcenter valve, which is a pilot assisted relief valve with a free flow check. With the relief valve set at around 1.3 times the maximum load induced pressure, the valve will prevent flow from taking place between ports 1 and 2. When pilot pressure is applied to port 3, the valve will meter the flow from port 1 to 2 compensating for any change in pilot pressure due to over-running or unstable loads. Free flow from port 2 to port 1 can take place freely through the check portion of the valve. These valves are ideal in most applications bringing stability, load holding, and hose failure protection when the valve is mounted onto or into the actuator. The spring chamber is connected to atmosphere so any back pressure will have no effect on the opening of the valve. At some point there will be leakage past the seals to atmosphere so the 4 ported valve should be considered as the best option. This is also available in a dual housing for bi-directional control.

SCHEMATIC

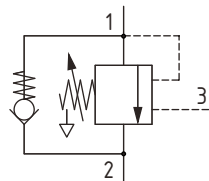

PERFORMANCE DATA

Rated pressure	350 bar [5000 psi]
Rated flow	120 l/min [32 US gpm]
Max total relief pressure	350 bar [5000 psi]
Max recommended load pressure at max setting	270 bar [3900 psi]
Pilot Ratio	3:1, 8:1
Leakage	0.3 ml/min nominal [5 drops/min]
Weight	0.59 kg [1.30 lb]
Cavity	A877

DIMENSIONS

mm [in]

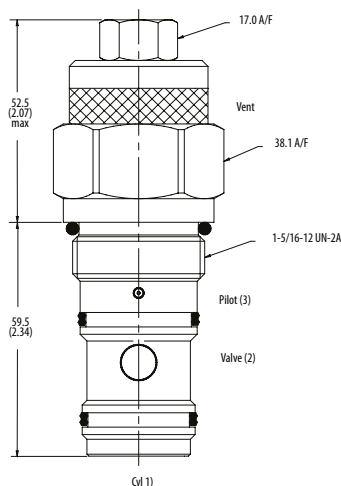

Turn CW to increase pressure setting and CCW to decrease pressure setting
Torque lock nut to 20-25 Nm [15-18 ft lbs]

Installation Torque
100 Nm [74 ft. lbs]

PERFORMANCE CURVES

Pressure Drop

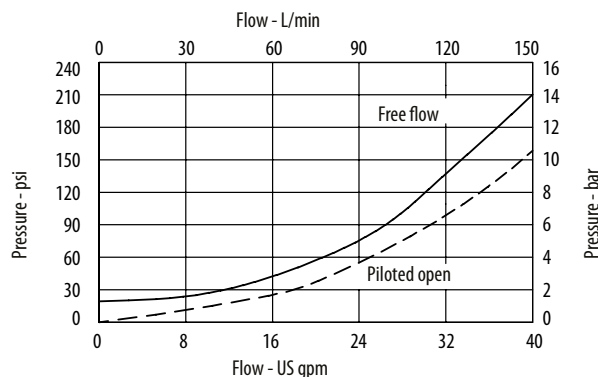

Motion Control Valves

1CEB120

Overcenter Valve, Fully Balanced, Differential Area, Atmospheric Vent, Port 3 Pilot

350 bar [5000 psi] • 120 l/min [32 US gpm]

■ SCHEMATIC

1CEEB150 (dual)

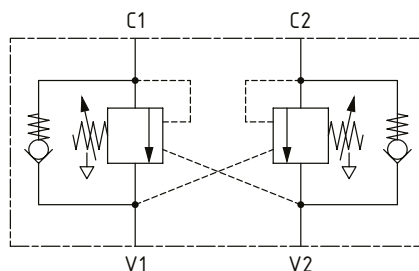

■ DIMENSIONS

mm [in]

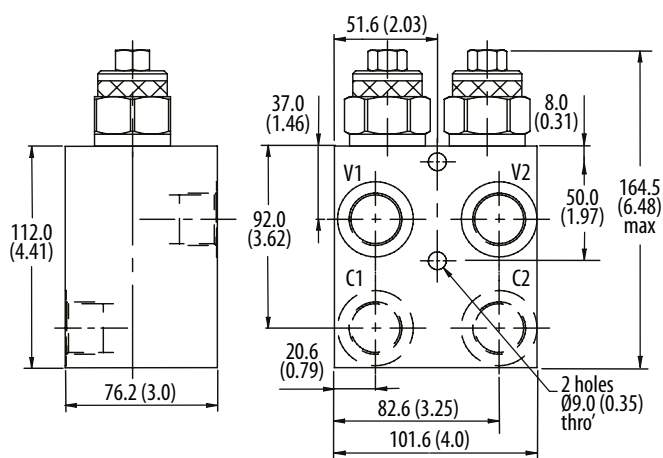

■ MODEL CODE

1CEB150 - P - 6W - 35 - S - 3 - 377 - 210

Basic Code

1CEB120 - No housing
1CEB150 - Cartridge and housing
1CEEB150 - Cartridges and dual housing

Adjustment Option

P - External

Housing

Code	Ports	Aluminum single	Steel single	Aluminum dual	Steel dual
Omit	No Housing				
6W	3/4" BSP Valve & Cyl Port. 1/4" BSP Pilot Port	B6898	B5544	C2543	C1200
12T	3/4" SAE Valve & Cyl Port. 1/4" SAE Pilot Port	B8200		C10629	C16434
16T	1" SAE Valve & Cyl Port. 1/4" SAE Pilot Port	B10708	B11814		

* Aluminum bodies are to be used for pressures less than 210 bar [3000 psi].

* Additional housings available

Pressure Range

Code	Bar	Psi
35	70-350	[1015-5000]
Standard Setting	210	[3000]

Std setting made at 4.5 l/min

Pressure Setting

Code Pressure setting in bar (10 bar increments within specified Pressure Range)
XXX-Standard setting (see Pressure Range for value). Example:

Code	Bar	Psi
210	210	[3000]

Housing Material

Omit - Aluminum/No housing
377 - Steel

Pilot Ratio

3 - 3:1
8 - 8:1

Seal Option

Code	Seal kit
S-Buna-N	SK417
SV-Viton	SK417V
P-Polyurethane/Buna-N	SK417-P

Motion Control Valves

1CEB300

Overcenter Valve, Fully Balanced, Differential Area, Atmospheric Vent, Port 3 Pilot

350 bar [5000 psi] • 300 l/min [80 US gpm]

DESCRIPTION AND OPERATION

This is a differential area overcenter valve, which is a pilot assisted relief valve with a free flow check. With the relief valve set at around 1.3 times the maximum load induced pressure, the valve will prevent flow from taking place between ports 1 and 2. When pilot pressure is applied to port 3, the valve will meter the flow from port 1 to 2 compensating for any change in pilot pressure due to over-running or unstable loads. Free flow from port 2 to port 1 can take place freely through the check portion of the valve. These valves are ideal in most applications bringing stability, load holding, and hose failure protection when the valve is mounted onto or into the actuator. The spring chamber is connected to atmosphere so any back pressure will have no effect on the opening of the valve. At some point there will be leakage past the seals to atmosphere so the 4 ported valve should be considered as the best option. This is also available in a dual housing for bi-directional control.

SCHEMATIC

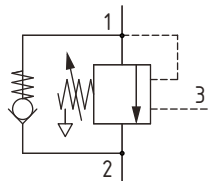

PERFORMANCE DATA

Rated pressure	350 bar [5000 psi]
Rated flow	300 l/min [80 US gpm]
Max total relief pressure	350 bar [5000 psi]
Max recommended load pressure at max setting	270 bar [3900 psi]
Pilot Ratio	3:1, 8:1
Leakage	4 ml/min nominal [60 drops/min]
Weight	0.91 kg [2.00 lb]
Cavity	A6935

DIMENSIONS

mm [in]

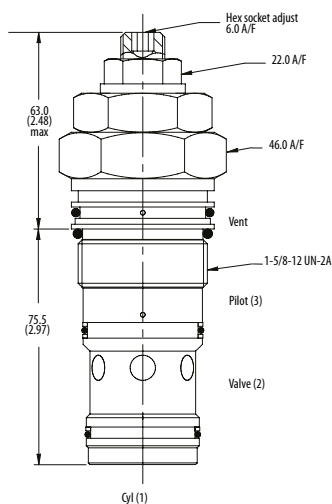

Turn CW to increase pressure setting and CCW to decrease pressure setting

Torque lock nut to 20-25 Nm [15-18 ft lbs]

Installation Torque
150 Nm [110 ft. lbs]

PERFORMANCE CURVES

Pressure Drop

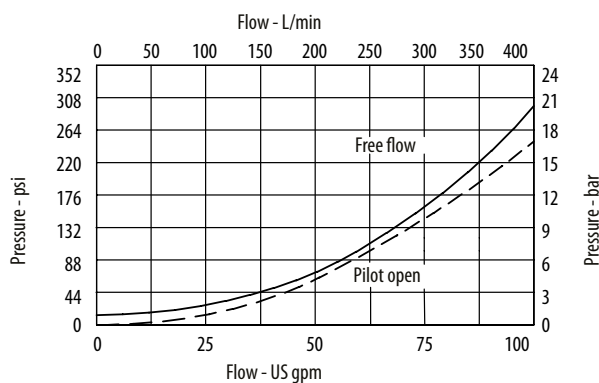

Motion Control Valves

1CEB300

Overcenter Valve, Fully Balanced, Differential Area, Atmospheric Vent, Port 3 Pilot

350 bar [5000 psi] • 300 l/min [80 US gpm]

■ SCHEMATIC

1CEEB350 (dual)

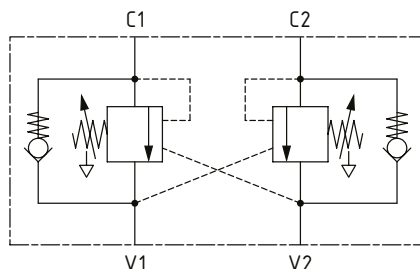

■ DIMENSIONS

mm [in]

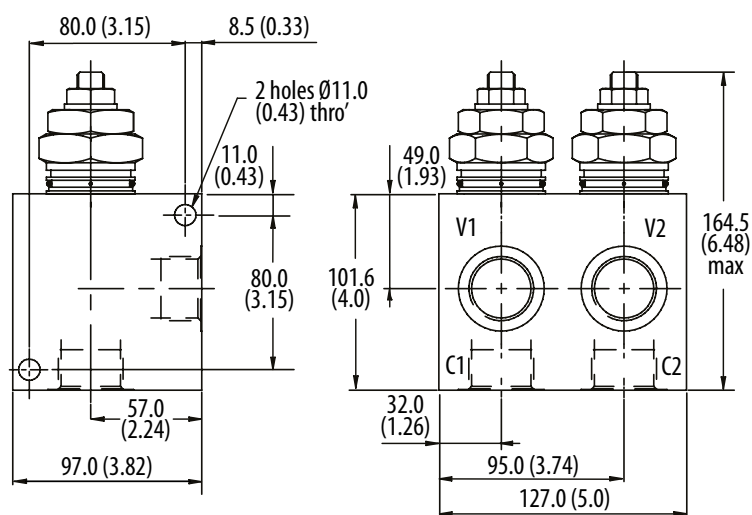

■ MODEL CODE

1CEB300 - F - 10W - 35 - S - 3 - 377 - 210

Basic Code

1CEB300 - No housing
1CEB350 - Cartridge and housing
1CEEB350 - Cartridges and dual housing

Adjustment Option

F - External

Housing

Code	Ports	Aluminum single	Steel single	Aluminum dual	Steel dual
Omit	No housing				
10W	1 1/4" BSP Valve & Cyl Port 1/4" BSP Pilot Port	B6814	B8610	C8704	C8705
20T	1 1/4" SAE Valve & Cyl Port 1/4" SAE Pilot Port	B10630	B11474	C10811	C11564

* Aluminum bodies are to be used for pressures less than 210 bar [3000 psi].

* Additional housings available

Pressure Range

Code	Bar	Psi
35	70-350	[1015-5000]
Standard Setting	210	[3000]

Std setting made at 4.5 l/min

Pressure Setting

Code Pressure setting in bar (10 bar increments within specified Pressure Range)
XXX-Standard setting (see Pressure Range for value). Example:

Code	Bar	Psi
210	210	[3000]

Housing Material

Omit - Aluminum/No housing
377 - Steel

Pilot Ratio

3 - 3:1
8 - 8:1

Seal Option

Code	Seal kit
S-Buna-N	SK686
SV-Viton	SK686V

Motion Control Valves

1SEB30

Overcenter Valve, Fully Balanced, Direct Acting, Atmospheric Vent, Port 3 Pilot

350 bar [5000 psi] • 30 l/min [8 US gpm]

DESCRIPTION AND OPERATION

This is a direct acting overcenter valve, which is a pilot assisted relief valve with a free flow check. With the relief valve set at around 1.3 times the maximum load induced pressure, the valve will prevent flow from taking place between ports 1 and 2. When pilot pressure is applied to port 3 the valve will meter the flow from port 1 to 2 compensating for any change in pilot pressure due to over-running or unstable loads. Free flow from port 2 to port 1 can take place freely through the check portion of the valve. These valves are ideal in most applications bringing stability, load holding, and hose failure protection when the valve is mounted onto or into the actuator. The spring chamber is connected to atmosphere, so any back pressure will have no effect on the opening of the valve. Over time, there may be leakage past the seals to atmosphere. For valves with a separate drain port, reference the 1CEBD products.

SCHEMATIC

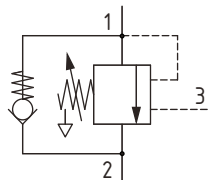

DIMENSIONS

mm [in]

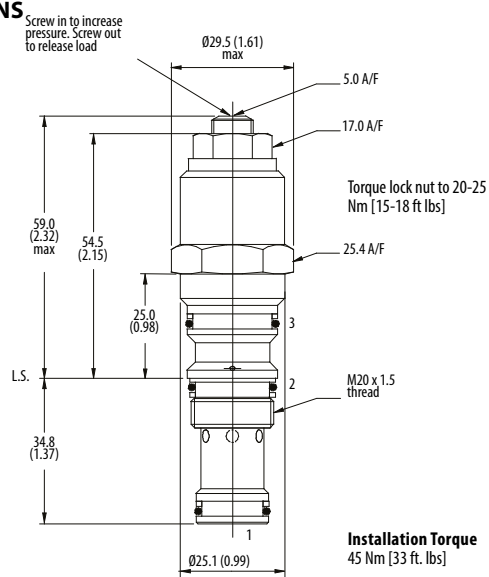

PERFORMANCE DATA

Rated pressure	350 bar [5000 psi]
Rated flow	30 l/min [8 US gpm]
Max total relief pressure	350 bar [5000 psi]
Max recommended load pressure at max setting	270 bar [3900 psi]
Pilot Ratio	5:1
Leakage	0.3 ml/min nominal [5 drops/min]
Weight	0.14 kg [0.30 lb]
Cavity	A20090-T11A

PERFORMANCE CURVES

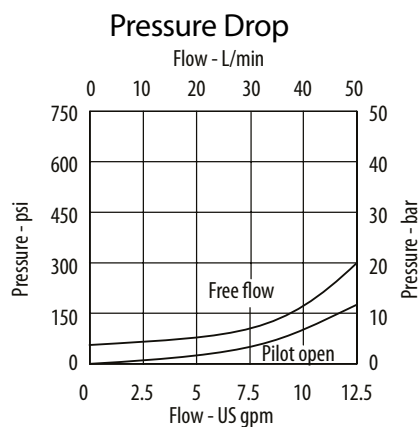

MODEL CODE

1SEB30 - F - 35 - S - 5 - 210

Adjustment Option

F - External

Pressure Range

Code	Bar	Psi
35	75-350	[1090-5000]
Standard Setting	210	[3000]

Std setting made at 4.5 l/min

Seal Option

Code	Seal kit
S-Buna-N	SK1079
SV-Viton	SK1079V

Pressure Setting

Code Pressure setting in bar (10 bar increments within specified Pressure Range)
XXX- Standard setting (see Pressure Range for value). Example:

Code	Bar	Psi
210	210	[3000]

Pilot Ratio

5 - 5:1

Motion Control Valves

1SEB90

Overcenter Valve, Fully Balanced, Direct Acting, Atmospheric Vent, Port 3 Pilot

350 bar [5000 psi] • 90 l/min [24 US gpm]

DESCRIPTION AND OPERATION

This is a direct acting overcenter valve, which is a pilot assisted relief valve with a free flow check. With the relief valve set at around 1.3 times the maximum load induced pressure, the valve will prevent flow from taking place between ports 1 and 2. When pilot pressure is applied to port 3 the valve will meter the flow from port 1 to 2 compensating for any change in pilot pressure due to over-running or unstable loads. Free flow from port 2 to port 1 can take place freely through the check portion of the valve. These valves are ideal in most applications bringing stability, load holding, and hose failure protection when the valve is mounted onto or into the actuator. The spring chamber is connected to atmosphere, so any back pressure will have no effect on the opening of the valve. Over time, there may be leakage past the seals to atmosphere. For valves with a separate drain port, reference the 1CEBD products.

SCHEMATIC

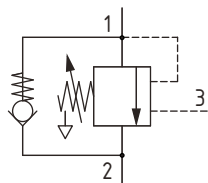

DIMENSIONS

mm [in]

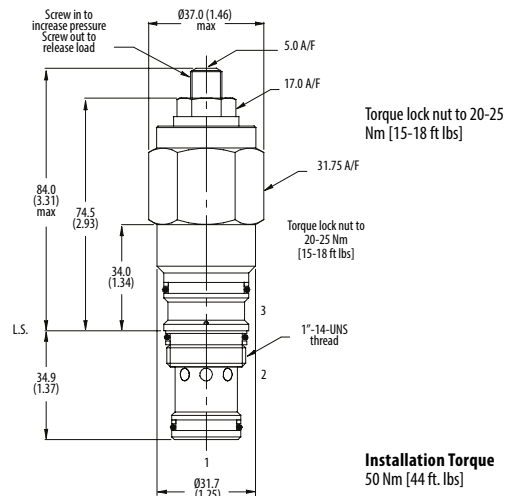

PERFORMANCE DATA

Rated pressure	350 bar [5000 psi]
Rated flow	90 l/min [24 US gpm]
Max total relief pressure	350 bar [5000 psi]
Max recommended load pressure at max setting	270 bar [3900 psi]
Pilot Ratio	4:1
Leakage	0.3 ml/min nominal [5 drops/min]
Weight	0.42 kg [0.92 lb]
Cavity	A20092-T2A

MODEL CODE

1SEB90 - F - 35 - S - 4 - 210

Adjustment Option

F - External
G - Tamper resistant

Pressure Range

Code	Bar	Psi
20	70-225	[1015-3260]
Standard Setting	100	[1450]
35	200-350	[2900-5000]
Standard Setting	210	[3000]

Std setting made at 4.5 l/min

Pressure Setting

Code - Pressure setting in bar (10 bar increments within specified Pressure Range)
XXX - Standard setting (see Pressure Range for value)
Example:

Code	Bar	Psi
210	210	[3000]

Pilot Ratio

4 - 4:1

Seal Option

Code	Seal kit
S-Buna-N	SK1096
SV-Viton	SK1096V

PERFORMANCE CURVES

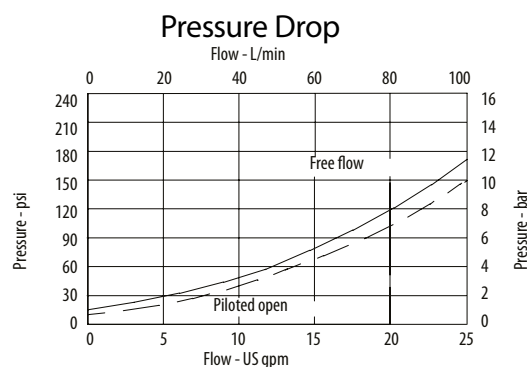

Motion Control Valves

1CEBD30

Overcenter Valve, Fully Balanced, Direct Acting, External Drain, Port 3 Pilot

350 bar [5000 psi] • 30 l/min [8 US gpm]

DESCRIPTION AND OPERATION

This is a direct acting overcenter valve, which is a pilot assisted relief valve with a free flow check. With the relief valve set at around 1.3 times the maximum load induced pressure, the valve will prevent flow from taking place between ports 1 and 2. When pilot pressure is applied to port 3, the valve will meter the flow from port 1 to 2, compensating for any change in pilot pressure due to over-running or unstable loads. Free flow from port 2 to port 1 can take place freely through the check portion of the valve. These valves are ideal in most applications bringing stability, load holding, and hose failure protection, when the valve is mounted onto or into the actuator. The spring chamber is connected to a drain port 4, so any back pressure in port 2 will have no effect on the pilot pressure required to open the valve.

SCHEMATIC

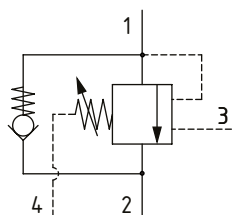

PERFORMANCE DATA

Rated pressure	350 bar [5000 psi]
Rated flow	30 l/min [8 US gpm]
Max total relief pressure	350 bar [5000 psi]
Max recommended load pressure at max setting	270 bar [3900 psi]
Pilot Ratio	5:1
Leakage	0.3 ml/min [5 drops/min]
Weight	0.14 kg [0.30 lb]
Cavity	A20530

MODEL CODE

1CEBD30 - F - 3W - 35 - S - 5 - 377 - 210

Basic Code

1CEBD30 - No housing

1CEBD35 - Cartridge and housing

Adjustment Option

F - External

Housing

Code	Ports	Aluminum	Steel
Omit	No housing		
3W	3/8" BSP Valve & Cyl. Port, 1/4" BSP Pilot and Vent Port	12007689	12007699
6T	#6 SAE Valve & Cyl. Port, #4 SAE Pilot and Vent Port	12007686	12007694

* Aluminum bodies are to be used for pressures less than 210 bar [3000 psi].

Pressure Range

Code	Bar	Psi
20	70-210	[1015-3000]
Standard Setting	100	[1450]
35	100-350	[1450-5000]
Standard Setting	210	[3000]

Std setting made at 4.5 l/min

Pressure Setting

Code Pressure setting in bar (10 bar increments within specified Pressure Range) XXX-Standard setting (see Pressure Range for value). Example:

Housing Material

Omit - Aluminum/No Housing

377 - Steel

Code	Bar	Psi
210	210	[3000]

Pilot Ratio

5 - 5:1

Seal Option

Code	Seal kit
S-Buna-N	SK1159
SV-Viton	SK1159V

DIMENSIONS

mm [in]

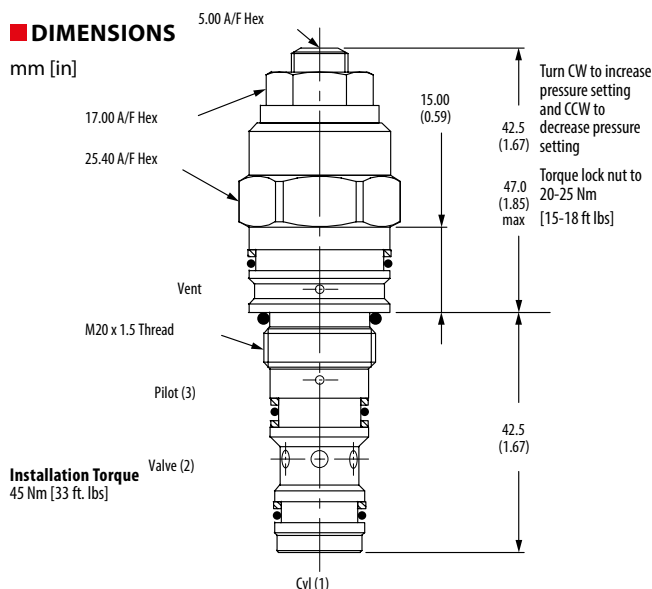

PERFORMANCE CURVES

Pressure Drop

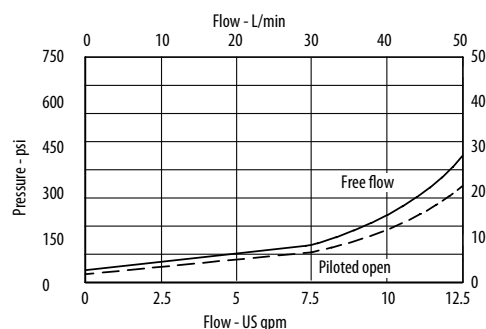

Motion Control Valves

1CEBD90

Overcenter Valve, Fully Balanced, Direct Acting, External Drain, Port 3 Pilot

350 bar [5000 psi] • 90 l/min [24 US gpm]

DESCRIPTION AND OPERATION

This is a direct acting overcenter valve, which is a pilot assisted relief valve with a free flow check. With the relief valve set at around 1.3 times the maximum load induced pressure, the valve will prevent flow from taking place between ports 1 and 2. When pilot pressure is applied to port 3, the valve will meter the flow from port 1 to 2, compensating for any change in pilot pressure due to over-running or unstable loads. Free flow from port 2 to port 1 can take place freely through the check portion of the valve. These valves are ideal in most applications bringing stability, load holding, and hose failure protection, when the valve is mounted onto or into the actuator. The spring chamber is connected to a drain port 4, so any back pressure in port 2 will have no effect on the pilot pressure required to open the valve.

SCHEMATIC

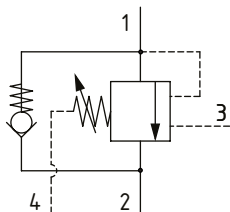

PERFORMANCE DATA

Rated pressure	350 bar [5000 psi]
Rated flow	90 l/min [24 US gpm]
Max total relief pressure	350 bar [5000 psi]
Max recommended load pressure at max setting	270 bar [3900 psi]
Pilot Ratio	4:1
Leakage	0.3 ml/min [5 drops/min]
Weight	0.29 kg [0.63 lb]
Cavity	A12196

MODEL CODE

1CEBD90 - F - 4W - 20 - P - 4 - 377 - 210

Basic Code

1CEBD90 - No housing
1CEBD95 - Cartridge and housing

Adjustment Option

F - External

Housing

Code	Ports	Aluminum Steel	
Omit	No housing		
4W	1/2" BSP Valve & Cyl. Port, 1/4" BSP Pilot and Vent Port	B16357	B23615
8T	#8 SAE Valve & Cyl. Port, #4 SAE Pilot and Vent Port	12007706	12007708

* Aluminum bodies are to be used for pressures less than 210 bar [3000 psi].

Pressure Range

Code	Bar	Psi
20	70-225	[1015-3260]
Standard Setting	100	[1450]
35	200-350	[2900-5000]
Standard Setting	210	[3000]

Std setting made at 4.5 l/min

Pressure Setting

Code Pressure setting in bar (10 bar increments within specified Pressure Range)
XXX - Standard setting (see Pressure Range for value). Example:

Code	Bar	Psi
210	210	[3000]

Housing Material

Omit - Aluminum/No Housing
377 - Steel

Pilot Ratio

4 - 4:1

Seal Option

Code	Seal kit
S - Buna-N	SK634
SV - Viton	SK634V
P - Polyurethane/Buna-N	SK634P

DIMENSIONS

mm [in]

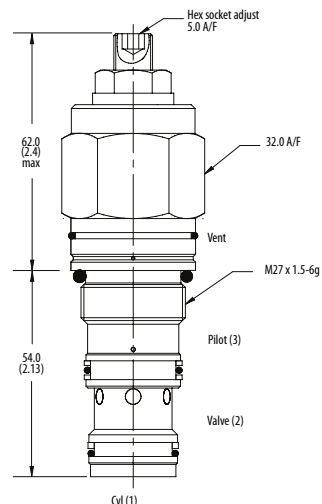

Turn CW to increase pressure setting and CCW to decrease pressure setting

Torque lock nut to 20-25 Nm [15-18 ft lbs]

Installation Torque
 60 Nm [44 ft. lbs]

PERFORMANCE CURVES

Pressure Drop

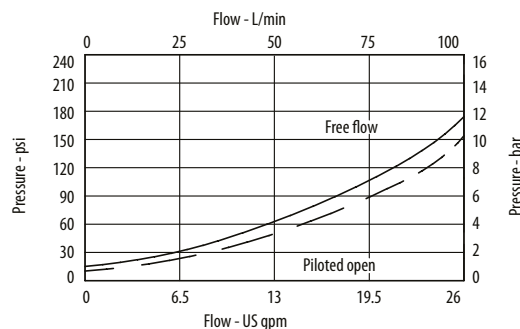

Motion Control Valves

1CEBD120

Overcenter Valve, Fully Balanced, Differential Area, External Drain, Port 3 Pilot

400 bar [5800 psi] • 180 l/min [47 US gpm]

DESCRIPTION AND OPERATION

This is a differential area overcenter valve, which is a pilot assisted relief valve with a free flow check. With the relief valve set at around 1.3 times the maximum load induced pressure, the valve will prevent flow from taking place between ports 1 and 2. When pilot pressure is applied to port 3, the valve will meter the flow from port 1 to 2, compensating for any change in pilot pressure due to over-running or unstable loads. Free flow from port 2 to port 1 can take place freely through the check portion of the valve. These valves are ideal in most applications bringing stability, load holding, and hose failure protection when the valve is mounted onto or into the actuator. The spring chamber is connected to a drain port 4, so any back pressure in port 2 will have no effect on the pilot pressure required to open the valve.

SCHEMATIC

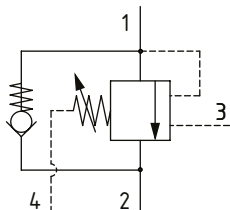

PERFORMANCE DATA

Rated pressure	400 bar [5800 psi]
Rated flow	180 l/min [47 US gpm]
Max total relief pressure	400 bar [5800 psi]
Max recommended load pressure at max setting	270 bar [3900 psi]
Pilot Ratio	3:1, 8:1, 12:1, 22:1
Leakage	0.3 ml/min [5 drops/min]
Weight	0.59 kg [1.30 lb]
Cavity	A6726

MODEL CODE

1CEBD120 - F - 6W - 35 - P - 8 - 377 - 210

Basic Code

1CEBD120 - No housing
1CEBD150 - Cartridge and housing

Adjustment Option

F - External

Housing

Code	Ports	Aluminum Steel	
Omit	No housing		
6W	3/4" BSP Valve & Cyl. Port, 1/4" BSP Pilot and Vent Port	12007710	12007715
12T	#12 SAE Valve & Cyl. Port, #4 SAE Pilot and Vent Port	12007709	12007712

* Aluminum bodies are to be used for pressures less than 210 bar [3000 psi].

* Additional housings available

Pressure Range

Code	Bar	Psi	Pilot Ratio
35	70-350	[1015-5000]	3:1 8:1 22:1
Standard Setting	350	[5000]	
40	70-400	[1015-5800]	12:1
Standard Setting	350	[5000]	

Std setting made at 4.5 l/min

DIMENSIONS

mm [in]

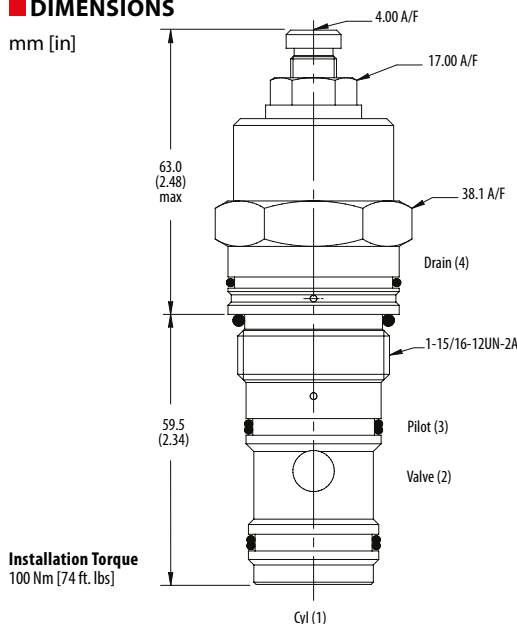

Turn CW to increase pressure setting and CCW to decrease pressure setting

Torque lock nut to 20-25 Nm [15-18 ft lbs]"

PERFORMANCE CURVES

Pressure Drop

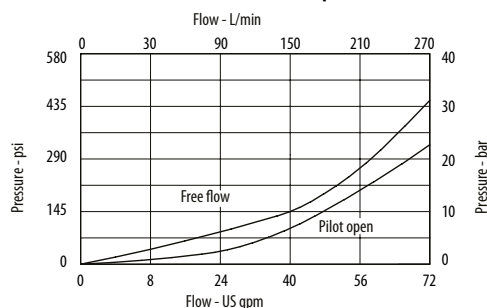

Pressure Setting

Code Pressure setting in bar (10 bar increments within specified Pressure Range)
XXX-Standard setting (see Pressure Range for value).
Example:

Code	Bar	Psi
210	210	[3000]

Housing Material

Omit - Aluminum/No Housing
377 - Steel

Pilot Ratio

3 - 3:1
8 - 8:1
12 - 12:1
22 - 22:1

Seal Option

Code	Seal kit
S-Buna-N	SK830
SV-Viton	SK830V
P-Polyurethane/Buna-N	SK830P

Motion Control Valves

1CEBD300

Overcenter Valve, Fully Balanced, Differential Area, External Drain, Port 3 Pilot

350 bar [5000 psi] • 300 l/min [80 US gpm]

DESCRIPTION AND OPERATION

This is a differential area overcenter valve, which is a pilot assisted relief valve with a free flow check. With the relief valve set at around 1.3 times the maximum load induced pressure, the valve will prevent flow from taking place between ports 1 and 2. When pilot pressure is applied to port 3, the valve will meter the flow from port 1 to 2, compensating for any change in pilot pressure due to over-running or unstable loads. Free flow from port 2 to port 1 can take place freely through the check portion of the valve. These valves are ideal in most applications bringing stability, load holding, and hose failure protection when the valve is mounted onto or into the actuator. The spring chamber is connected to a drain port 4, so any back pressure in port 2 will have no effect on the pilot pressure required to open the valve.

SCHEMATIC

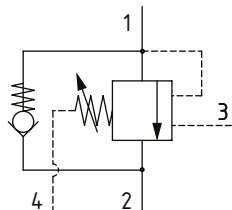

PERFORMANCE DATA

Rated pressure	350 bar [5000 psi]
Rated flow	300 l/min [80 US gpm]
Max total relief pressure	350 bar [5000 psi]
Max recommended load pressure at max setting	270 bar [3900 psi]
Pilot Ratio	3:1, 8:1
Leakage	4 ml/min [60 drops/min]
Weight	0.59 kg [1.30 lb]
Cavity	A13098

MODEL CODE

1CEBD300 - F - 10W - 35 - S - 3 - 377 - 210

Basic Code

1CEBD300 - No housing
1CEBD350 - Cartridge and housing

Adjustment Option

F - External

Housing

Code	Ports	Aluminum Steel	
Omit	No housing		
10W	1 1/4" BSP Valve & Cyl. Port, 1/4" BSP Pilot and Vent Port	12007720	12007722
20T	#20 SAE Valve & Cyl. Port, #4 SAE Pilot and Vent Port	12007719	12007721

* Aluminum bodies are to be used for pressures less than 210 bar [3000 psi].

Pressure Range

Code	Bar	Psi
35	70-350	[1015-5000]
Standard Setting	210	[3000]

Std setting made at 4.5 l/min

Pressure Setting

Code Pressure setting in bar
 (10 bar increments within specified
 Pressure Range)
XXX-Standard setting (see Pressure Range
 for value). Example:

Code	Bar	Psi
210	210	[3000]

Housing Material

Omit - Aluminum/No Housing
377 - Steel

Pilot Ratio

3 - 3:1
8 - 8:1

Seal Option

Code	Seal kit
S -Buna-N	SK686
SV -Viton	SK686V
P -Polyurethane/Buna-N	SK686P

DIMENSIONS

mm [in]

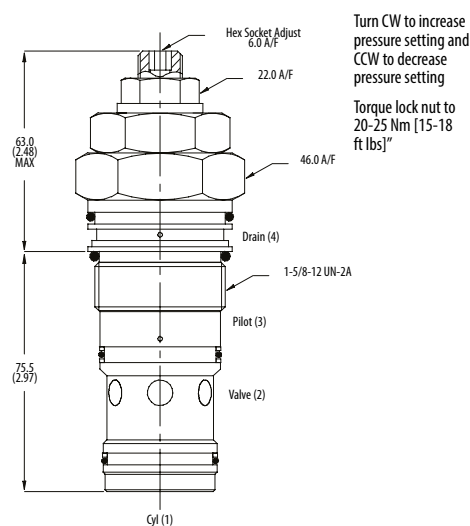

Installation Torque
 150 Nm [110 ft. lbs]

Turn CW to increase
 pressure setting and
 CCW to decrease
 pressure setting

Torque lock nut to
 20-25 Nm [15-18
 ft lbs]"

PERFORMANCE CURVES

Pressure Drop

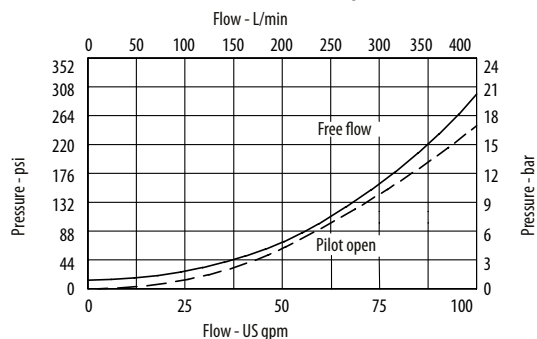

Motion Control Valves

1CEL30

Overcenter Valve, Two Stage Counterbalance, Direct Acting, Port 3 Pilot

380 bar [5500 psi] • 30 l/min [8 US gpm]

DESCRIPTION AND OPERATION

This is a direct acting overcenter valve, which is a pilot assisted relief valve with a free flow check. With the total relief pressure setting (fixed pressure relief setting plus counterbalance pressure setting) set at around 1.3 times the maximum load induced pressure, the valve will prevent flow from taking place between ports 1 and 2. The relationship between the two settings will be application dependent. The more unstable the application, the higher the counterbalance pressure setting should be with the fixed pressure relief setting making up the remainder of the setting. When pilot pressure is applied to port 3, it acts on two separate areas, one gives a very low pilot ratio 0.4 to 1 and the other slightly higher 4.3 to 1. When piloted, the valve will meter the flow from port 1 to 2 compensating for any change in pilot pressure due to over-running or unstable loads. If the load pressure decays very quickly, then the lower pilot ratio poppet will return at a high pilot pressure preventing total loss of control and subsequent instability. As the pilot pressure increases, the counterbalance portion of the pressure will be removed allowing full cylinder force to ensue. Free flow from port 2 to port 1 can take place freely through the check portion of the valve. These valves are ideal in the most severe applications bringing stability, load holding, and hose failure protection to long slender booms and traditionally unstable applications. This is also available in a dual housing for bi-directional control.

SCHEMATIC

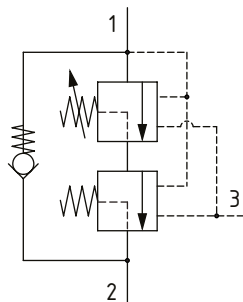

PERFORMANCE DATA

Rated pressure	380 bar [5500 psi]
Rated flow	30 l/min [8 US gpm]
Max total relief pressure	380 bar [5500 psi]
Max recommended load pressure at max setting	290 bar [4200 psi]
Pilot Ratio	4.3:1 (Primary); 0.4:1 (Secondary)
Leakage	0.3 ml/min [5 drops/min]
Weight	0.15 kg [0.33 lb]
Cavity	A6610

DIMENSIONS

mm [in]

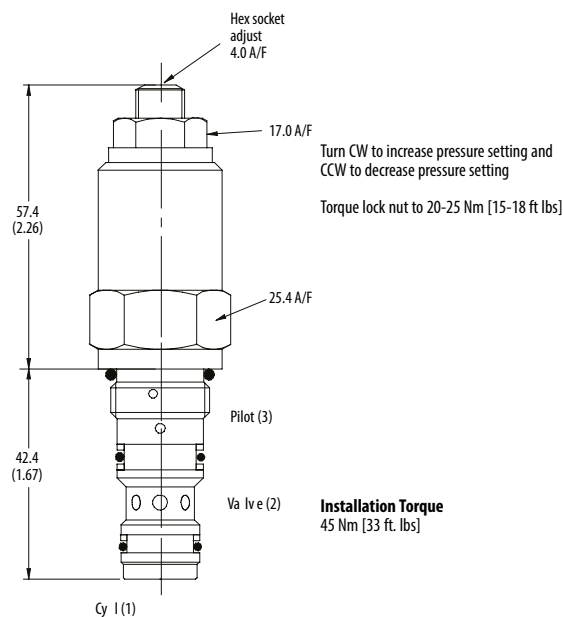

PERFORMANCE CURVES

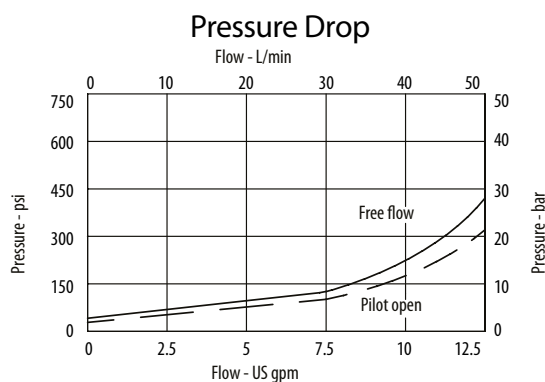

Motion Control Valves

1CEL30

Overcenter Valve, Two Stage Counterbalance, Direct Acting, Port 3 Pilot

380 bar [5500 psi] • 30 l/min [8 US gpm]

■ SCHEMATIC

1CEEL34 (dual)

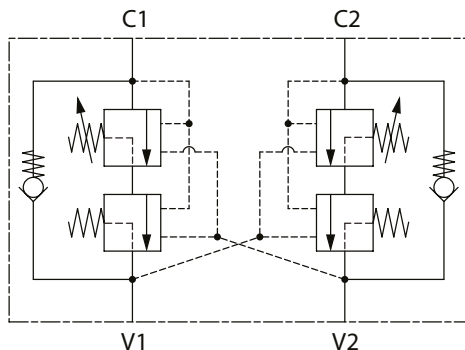

■ DIMENSIONS

mm [in]

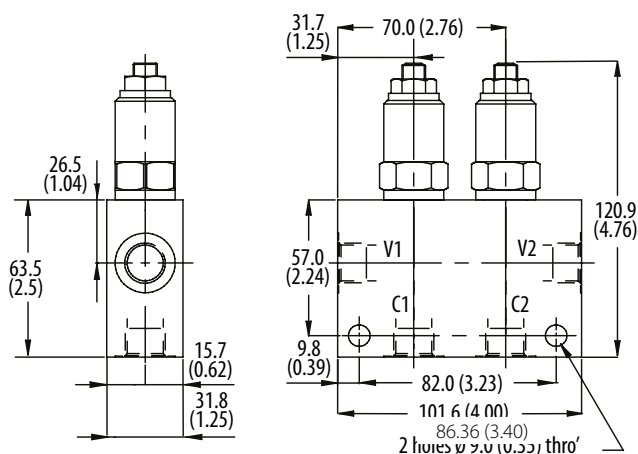

■ MODEL CODE

1CEL35 - F - 3W - 30 - S - 230 - 50 - 377

Basic Code

1CEL30 - No housing
1CEL35 - Cartridge and housing
1CEEL34 - Cartridge and dual housing

Adjustment Option

F - External
G - Tamper resistant

Housing

Code	Ports	Aluminum single	Steel single	Aluminum dual	Steel dual
Omit	No housing				
3W	3/8" BSP valve & cylinder port. 1/4" BSP pilot port	B6743	B12823	B6836	B13803
6T	3/8" SAE valve & cylinder port. 1/4" SAE pilot port	B10536	B10805		
8T	1/2" SAE valve & cylinder port. 1/4" SAE pilot port	B7884	B11811	B30237	B11812

* Aluminum bodies are to be used for pressures less than 210 bar [3000 psi].

* Additional housings available

Housing Material

Omit - Aluminum/No housing
377 - Steel

Fixed Pressure Setting

Code - Pressure setting in bar (10 bar increments within specified Pressure Range)

Code	Bar	Psi
230	230	[3335]

Counterbalance Pressure Setting

Code - Pressure setting in bar (10 bar increments within specified Pressure Range)

Code	Bar	Psi
50	50	[725]

Seal Option

Code	Seal Kit
S-Buna-N	SK395
SV-Viton	SK395V

Total Relief Pressure Range

Code	Total Relief Pressure Range		Fixed Pressure Range		Counterbalance Pressure Range	
	Bar	Psi	Bar	Psi	Bar	Psi
20	170-300	[2465-4350]	150-200	[2175-2900]	20-120	[290-1740]
Standard Setting	220	[3190]	170	[2465]	50	[725]
30	240-370	[3480-5370]	210-280	[3000-4060]	20-120	[290-1740]
Standard Setting	280	[4060]	230	[3330]	50	[725]
40	270-380	[3900-5500]	290-310	[4200-4500]	20-120	[290-1740]
Standard Setting	350	[5000]	300	[4350]	50	[725]

Std setting made at 4.5 l/min

*Note: Total relief pressure setting = fixed pressure setting + counterbalance pressure setting

Motion Control Valves

1CEL90

Overcenter Valve, Two Stage Counterbalance, Direct Acting, Port 3 Pilot

380 bar [5500 psi] • 90 l/min [24 US gpm]

DESCRIPTION AND OPERATION

This is a direct acting overcenter valve, which is a pilot assisted relief valve with a free flow check. With the total relief pressure setting (fixed pressure relief setting plus counterbalance pressure setting) set at around 1.3 times the maximum load induced pressure, the valve will prevent flow from taking place between ports 1 and 2. The relationship between the two settings will be application dependent. The more unstable the application, the higher the counterbalance pressure setting should be with the fixed pressure relief setting making up the remainder of the setting. When pilot pressure is applied to port 3, it acts on two separate areas, one gives a very low pilot ratio 0.4 to 1 and the other slightly higher 4.3 to 1. When piloted, the valve will meter the flow from port 1 to 2 compensating for any change in pilot pressure due to over-running or unstable loads. If the load pressure decays very quickly, then the lower pilot ratio poppet will return at a high pilot pressure preventing total loss of control and subsequent instability. As the pilot pressure increases, the counterbalance portion of the pressure will be removed allowing full cylinder force to ensue. Free flow from port 2 to port 1 can take place freely through the check portion of the valve. These valves are ideal in the most severe applications bringing stability, load holding, and hose failure protection to long slender booms and traditionally unstable applications. This is also available in a dual housing for bi-directional control.

SCHEMATIC

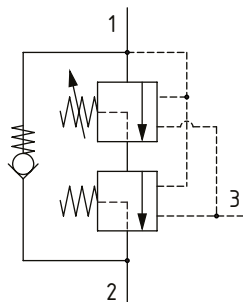

DIMENSIONS

mm [in]

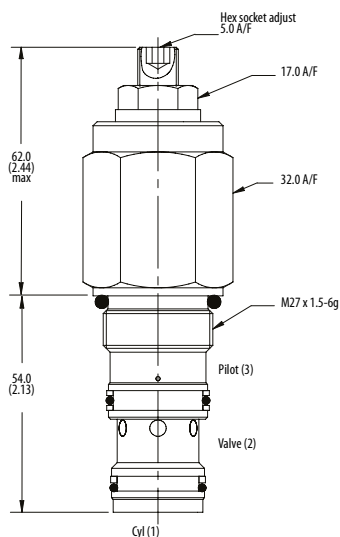

Turn CW to increase pressure setting and
CCW to decrease pressure setting

Torque lock nut to 20-25 Nm [15-18 ft lbs]

Installation Torque
60 Nm [44 ft. lbs]

PERFORMANCE CURVES

Pressure Drop

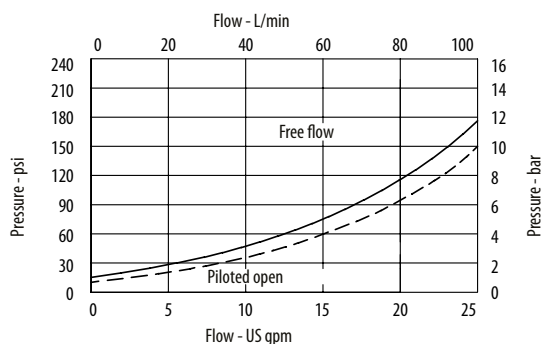

Motion Control Valves

1CEL90

Overcenter Valve, Two Stage Counterbalance, Direct Acting, Port 3 Pilot

380 bar [5500 psi] • 90 l/min [24 US gpm]

■ SCHEMATIC

1CEEL95 (dual)

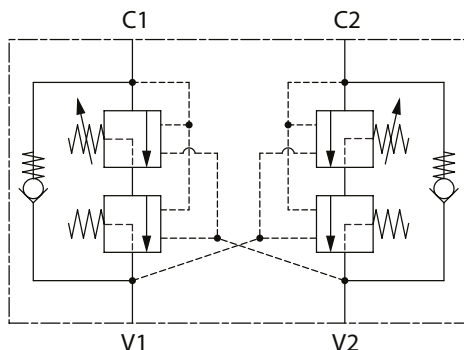

■ DIMENSIONS

mm [in]

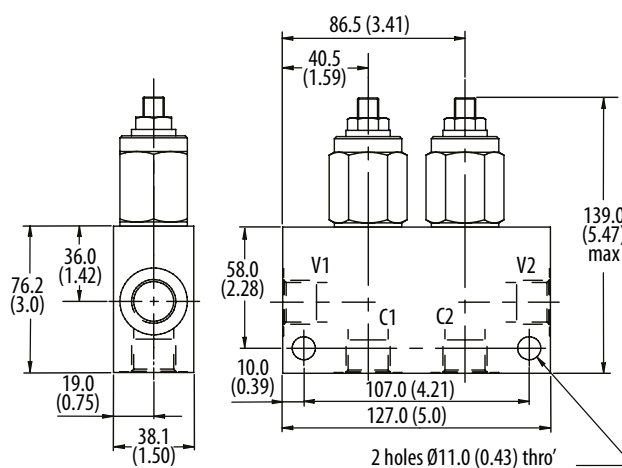

■ MODEL CODE

1CEL95 - F - 4W - 30 - S - 220 - 60 - 377

Basic Code

1CEL90 - No housing
1CEL95 - Cartridge and housing
1CEEL95 - Cartridges and dual housing

Adjustment Option

F - External
G - Tamper resistant

Housing

Code	Ports	Aluminum single	Steel single	Aluminum dual	Steel dual
Omit	No housing				
4W	1/2" BSP Valve & Cyl Port 1/4" BSP Pilot Port	B13625	B13626	C13627	C13628
8T	1/2" SAE Valve & Cyl Port 1/4" SAE Pilot Port	B10806	B10922	C10807	C11561

* Aluminum bodies are to be used for pressures less than 210 bar [3000 psi].

* Additional housings available

Housing Material

Omit - Aluminum/No housing
377 - Steel

Counterbalance Pressure Setting

Code - Pressure setting in bar (10 bar increments within specified Pressure Range)

Code	Bar	Psi
60	60	[870]

Fixed Pressure Setting

Code - Pressure setting in bar (10 bar increments within specified Pressure Range)

Code	Bar	Psi
220	220	[3190]

Seal Option

Code	Seal kit
S-Buna-N	SK633
SV-Viton	SK633V

Total Relief Pressure Range

Code	Total Relief Pressure Range		Fixed Pressure Range		Counterbalance Pressure Range	
	Bar	Psi	Bar	Psi	Bar	Psi
20	170-350	[2465-5000]	150-170	[2175-2465]	20-180	[290-2610]
	Standard Setting	220 [3190]	160 [2320]	60 [870]		
30	210-380	[3000-5500]	190-230	[2755-3330]	20-180	[290-2610]
	Standard Setting	280 [4060]	220 [3190]	60 [870]		

Std setting made at 4.5 l/min

*Note: Total relief pressure setting = fixed pressure setting + counterbalance pressure setting

Motion Control Valves

1CEL140

Overcenter Valve, Two Stage Counterbalance, Direct Acting, Port 3 Pilot

380 bar [5500 psi] • 140 l/min [37 US gpm]

DESCRIPTION AND OPERATION

This is a direct acting overcenter valve, which is a pilot assisted relief valve with a free flow check. With the total relief pressure setting (fixed pressure relief setting plus counterbalance pressure setting) set at around 1.3 times the maximum load induced pressure, the valve will prevent flow from taking place between ports 1 and 2. The relationship between the two settings will be application dependent. The more unstable the application, the higher the counterbalance pressure setting should be with the fixed pressure relief setting making up the remainder of the setting. When pilot pressure is applied to port 3, it acts on two separate areas, one gives a very low pilot ratio 0.4 to 1 and the other slightly higher 4.3 to 1. When piloted, the valve will meter the flow from port 1 to 2 compensating for any change in pilot pressure due to over-running or unstable loads. If the load pressure decays very quickly, then the lower pilot ratio poppet will return at a high pilot pressure preventing total loss of control and subsequent instability. As the pilot pressure increases, the counterbalance portion of the pressure will be removed allowing full cylinder force to ensue. Free flow from port 2 to port 1 can take place freely through the check portion of the valve. These valves are ideal in the most severe applications bringing stability, load holding, and hose failure protection to long slender booms and traditionally unstable applications. This is also available in a dual housing for bi-directional control.

SCHEMATIC

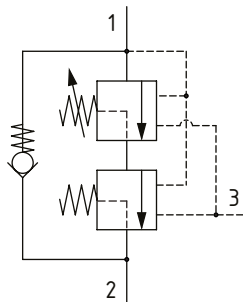

DIMENSIONS

mm [in]

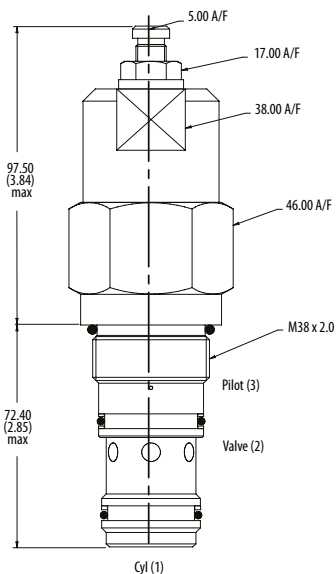

Turn CW to increase pressure setting and
CCW to decrease pressure setting

Torque lock nut to 20-25 Nm [15-18 ft lbs]

Installation Torque
150 Nm [110 ft. lbs]

PERFORMANCE CURVES

Pressure Drop

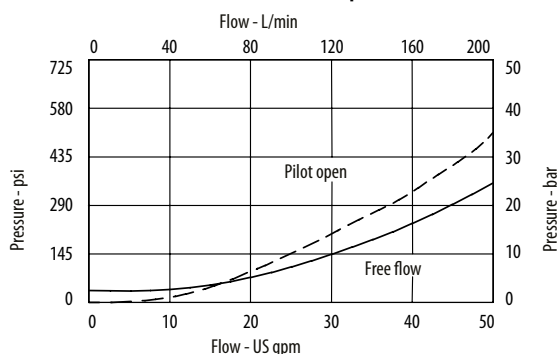

Motion Control Valves

1CEL140

Overcenter Valve, Two Stage Counterbalance, Direct Acting, Port 3 Pilot

380 bar [5500 psi] • 140 l/min [37 US gpm]

■ SCHEMATIC

1CEEL145 (dual)

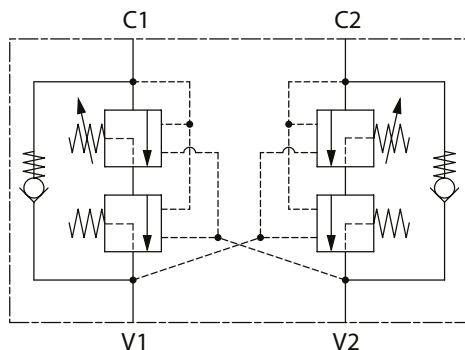

■ DIMENSIONS

mm [in]

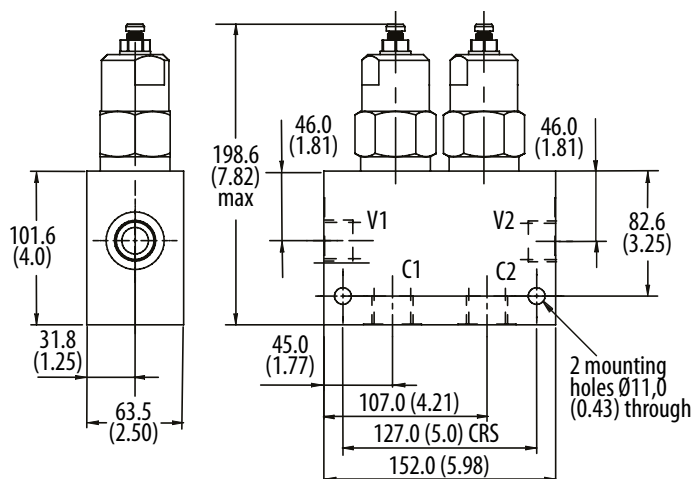

■ MODEL CODE

1CEL145 - F - 6W - 30 - S - 220 - 60 - 377

Basic Code

1CEL140 - No housing
1CEL145 - Cartridge and housing
1CEEL145 - Cartridges and dual housing

Adjustment Option

F - External

Housing

Code	Ports	Aluminum single	Steel single	Aluminum dual	Steel dual
Omit	No housing				
6W	3/4" BSP Valve & Cyl Port. 1/4" BSP Pilot Port	B20105	B20106		
8W	1" BSP Valve & Cyl Port. 1/4" BSP Pilot Port	B20107	B20108	C20285	C20287
16T	1" SAE Valve & Cyl Port. 1/4" SAE Pilot Port	B11946	B11947	C30105	C30106

* Aluminum bodies are to be used for pressures less than 210 bar [3000 psi].

* Additional housings available

Housing Material

Omit - Aluminum/No housing
377 - Steel

Fixed Pressure Setting

Code - Pressure setting in bar (10 bar increments within specified Pressure Range)

Code	Bar	Psi
220	220	[3190]

Seal Option

Code	Seal kit
S-Buna-N	SK1108
SV-Viton	SK1108V

Counterbalance Pressure Setting

Code - Pressure setting in bar (10 bar increments within specified Pressure Range)

Code	Bar	Psi
60	60	[870]

Total Relief Pressure Range

Code	Total Relief Pressure Range		Fixed Pressure Range		Counterbalance Pressure Range	
	Bar	Psi	Bar	Psi	Bar	Psi
20	170-300	[2465-4350]	150-200	[2175-2900]	20-120	[290-1740]
Standard Setting	220	[3190]	170	[2465]	50	[725]
30	240-370	[3480-5370]	210-280	[3000-4060]	20-120	[290-1740]
Standard Setting	280	[4060]	230	[3330]	50	[725]
40	270-380	[3900-5500]	290-310	[4200-4500]	20-120	[290-1740]
Standard Setting	350	[5000]	300	[4350]	50	[725]

Std setting made at 4.5 l/min

Motion Control Valves

1SEL30

Overcenter Valve, Two Stage Counterbalance, Direct Acting, Port 3 Pilot

380 bar [5500 psi] • 30 l/min [8 US gpm]

DESCRIPTION AND OPERATION

This is a direct acting overcenter valve, which is a pilot assisted relief valve with a free flow check. With the total relief pressure setting (fixed pressure relief setting plus counterbalance pressure setting) set at around 1.3 times the maximum load induced pressure, the valve will prevent flow from taking place between ports 1 and 2. The relationship between the two settings will be application dependent. The more unstable the application, the higher the counterbalance pressure setting should be with the fixed pressure relief setting making up the remainder of the setting. When pilot pressure is applied to port 3, it acts on two separate areas, one gives a very low pilot ratio 0.4 to 1 and the other slightly higher 4.3 to 1. When piloted, the valve will meter the flow from port 1 to 2 compensating for any change in pilot pressure due to over-running or unstable loads. If the load pressure decays very quickly, then the lower pilot ratio poppet will return at a high pilot pressure preventing total loss of control and subsequent instability. As the pilot pressure increases, the counterbalance portion of the pressure will be removed allowing full cylinder force to ensue. Free flow from port 2 to port 1 can take place freely through the check portion of the valve. These valves are ideal in the most severe applications bringing stability, load holding, and hose failure protection to long slender booms and traditionally unstable applications.

SCHEMATIC

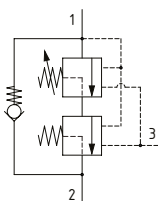

PERFORMANCE DATA

Rated pressure	380 bar [5500 psi]
Rated flow	30 l/min [8 US gpm]
Max total relief pressure	380 bar [5500 psi]
Max recommended load pressure at max setting	280 bar [4000 psi]
Pilot Ratio	4.3:1 (Primary); 0.4:1 (Secondary)
Leakage	0.3 ml/min nominal [5 drops/min]
Weight	0.15 kg [0.33 lb]
Cavity	A20090-T11A

MODEL CODE

1SEL30 - F - 30 - S - 230 - 50

Adjustment Option

F - External

G - Tamper resistant

Total Relief Pressure Range

Code	Total Relief Pressure Range		Fixed Pressure Range		Counterbalance Pressure Range	
	Bar	Psi	Bar	Psi	Bar	Psi
20	170-300	[2465-4350]	150-200	[2175-2900]	20-120	[290-1740]
Standard Setting	220	[3190]	170	[2465]	50	[725]
30	240-370	[3480-5370]	210-280	[3000-4060]	20-120	[290-1740]
Standard Setting	280	[4060]	230	[3330]	50	[725]
40	270-380	[3900-5500]	290-310	[4200-4500]	20-120	[290-1740]
Standard Setting	350	[5000]	300	[4350]	50	[725]

Std setting made at 4.5 l/min

*Note: Total relief pressure setting = fixed pressure setting + counterbalance pressure setting

Counterbalance Pressure Setting

Code - Pressure setting in bar (10 bar increments within specified Pressure Range)

Code	Bar	Psi
50	50	[725]

Fixed Pressure Setting

Code - Pressure setting in bar (10 bar increments within specified Pressure Range)

Code	Bar	Psi
230	230	[3335]

Seal Option

Code	Seal kit
S	Buna-N SK1079
SV	Viton SK1079V

DIMENSIONS

mm [in]

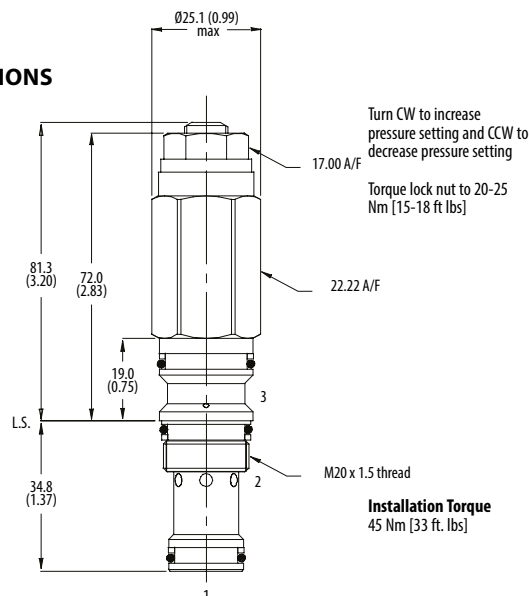

PERFORMANCE CURVES

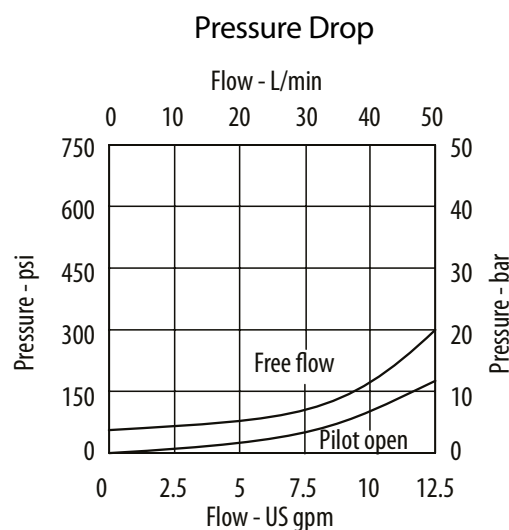

Motion Control Valves

1SEL90

Overcenter Valve, Two Stage Counterbalance, Direct Acting, Port 3 Pilot

380 bar [5500 psi] • 90 l/min [24 US gpm]

DESCRIPTION AND OPERATION

This is a direct acting overcenter valve, which is a pilot assisted relief valve with a free flow check. With the total relief pressure setting (fixed pressure relief setting plus counterbalance pressure setting) set at around 1.3 times the maximum load induced pressure, the valve will prevent flow from taking place between ports 1 and 2. The relationship between the two settings will be application dependent. The more unstable the application, the higher the counterbalance pressure setting should be with the fixed pressure relief setting making up the remainder of the setting. When pilot pressure is applied to port 3, it acts on two separate areas, one gives a very low pilot ratio 0.4 to 1 and the other slightly higher 4.3 to 1. When piloted, the valve will meter the flow from port 1 to 2 compensating for any change in pilot pressure due to over-running or unstable loads. If the load pressure decays very quickly, then the lower pilot ratio poppet will return at a high pilot pressure preventing total loss of control and subsequent instability. As the pilot pressure increases, the counterbalance portion of the pressure will be removed allowing full cylinder force to ensue. Free flow from port 2 to port 1 can take place freely through the check portion of the valve. These valves are ideal in the most severe applications bringing stability, load holding, and hose failure protection to long slender booms and traditionally unstable applications.

SCHEMATIC

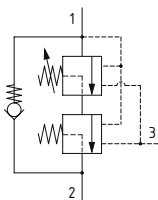

PERFORMANCE DATA

Rated pressure	380 bar [5500 psi]
Rated flow	90 l/min [24 US gpm]
Max total relief pressure	380 bar [5500 psi]
Max recommended load pressure at max setting	280 bar [4000 psi]
Pilot Ratio	5.6:1 (Primary); 0.7:1 (Secondary)
Leakage	0.3 ml/min nominal [5 drops/min]
Weight	0.42 kg [0.92 lb]
Cavity	A20092-T2A

MODEL CODE

1SEL90 - F - 30 - S - 220 - 60

Adjustment Option

F - External
G - Tamper resistant

Total Relief Pressure Range

Code	Total Relief Pressure Range		Fixed Pressure Range		Counterbalance Pressure Range	
	Bar	Psi	Bar	Psi	Bar	Psi
20	170-350	[2465-5000]	150-170	[2175-2465]	20-180	[290-2610]
Standard Setting	220	[3190]	160	[2320]	60	[870]
30	210-380	[3000-5500]	190-230	[2755-3330]	20-180	[290-2610]
Standard Setting	280	[4060]	220	[3190]	60	[870]

Std setting made at 4.5 l/min

*Note: Total relief pressure setting = fixed pressure setting + counterbalance pressure setting

Counterbalance Pressure Setting

Code - Pressure setting in bar (10 bar increments within specified Pressure Range)

Code	Bar	Psi
60	60	[870]

Fixed Pressure Setting

Code - Pressure setting in bar (10 bar increments within specified Pressure Range)

Code	Bar	Psi
220	220	[3190]

Seal Option

Code	Seal kit
S -Buna-N	SK1093
SV -Viton	SK1093V

DIMENSIONS

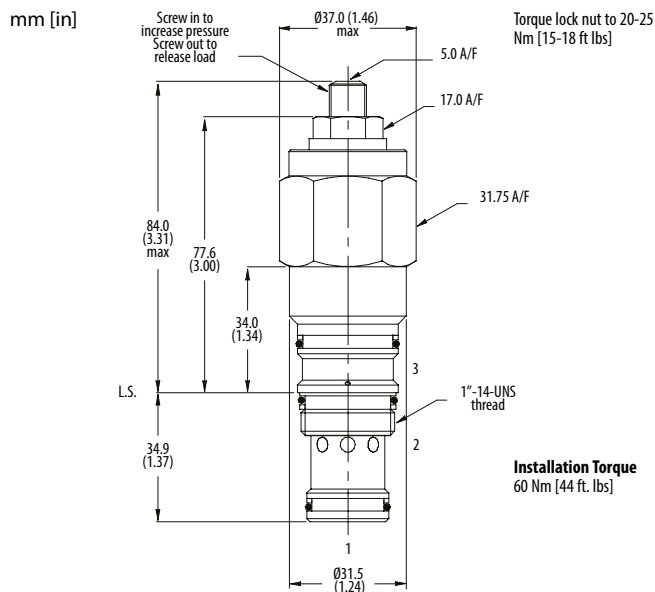

PERFORMANCE CURVES

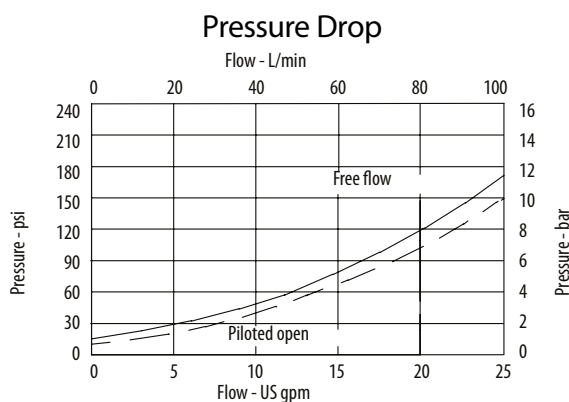

Motion Control Valves

1SEL140

Overcenter Valve, Two Stage Counterbalance, Direct Acting, Port 3 Pilot

380 bar [5500 psi] • 140 l/min [37 US gpm]

DESCRIPTION AND OPERATION

This is a direct acting overcenter valve, which is a pilot assisted relief valve with a free flow check. With the total relief pressure setting (fixed pressure relief setting plus counterbalance pressure setting) set at around 1.3 times the maximum load induced pressure, the valve will prevent flow from taking place between ports 1 and 2. The relationship between the two settings will be application dependent. The more unstable the application, the higher the counterbalance pressure setting should be with the fixed pressure relief setting making up the remainder of the setting. When pilot pressure is applied to port 3, it acts on two separate areas, one gives a very low pilot ratio 0.4 to 1 and the other slightly higher 4.3 to 1. When piloted, the valve will meter the flow from port 1 to 2 compensating for any change in pilot pressure due to over-running or unstable loads. If the load pressure decays very quickly, then the lower pilot ratio poppet will return at a high pilot pressure preventing total loss of control and subsequent instability. As the pilot pressure increases, the counterbalance portion of the pressure will be removed allowing full cylinder force to ensue. Free flow from port 2 to port 1 can take place freely through the check portion of the valve. These valves are ideal in the most severe applications bringing stability, load holding, and hose failure protection to long slender booms and traditionally unstable applications.

SCHEMATIC

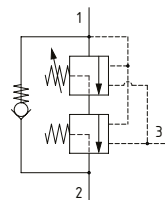

PERFORMANCE DATA

Rated pressure	380 bar [5500 psi]
Rated flow	140 l/min [37 US gpm]
Max total relief pressure	380 bar [5500 psi]
Max recommended load pressure at max setting	280 bar [4000 psi]
Pilot Ratio	6.1:1 (Primary); 0.5:1 (Secondary)
Leakage	0.3 ml/min nominal [5 drops/min]
Weight	1.2 kg [2.5 lb]
Cavity	A20094-T17A

MODEL CODE

1SEL140 - F - 30 - S - 220 - 60

Adjustment Option

F - External

Total Relief Pressure Range

Code	Total Relief Pressure Range		Fixed Pressure Range		Counterbalance Pressure Range	
	Bar	Psi	Bar	Psi	Bar	Psi
20	170-320	[2465-4640]	150-200	[2175-2900]	20-100	[290-1450]
Standard Setting	220	[3190]	160	[2320]	60	[870]
30	230-380	[3480-5500]	220-270	[3190-3900]	20-100	[290-1450]
Standard Setting	280	[4060]	220	[3190]	60	[870]
40	310-380	[4500-5500]	250-310	[3630-4500]	20-100	[290-1450]
Standard Setting	350	[5000]	290	[4200]	60	[870]

Std setting made at 4.5 l/min

*Note: Total relief pressure setting = fixed pressure setting + counterbalance pressure setting

Counterbalance Pressure Setting

Code - Pressure setting in bar (10 bar increments within specified Pressure Range)

Code	Bar	Psi
60	60	[870]

Fixed Pressure Setting

Code - Pressure setting in bar (10 bar increments within specified Pressure Range)

Code	Bar	Psi
220	220	[3190]

Seal Option

Code Seal kit

S-Buna-N SK1116

SV-Viton SK1116V

DIMENSIONS

mm [in]

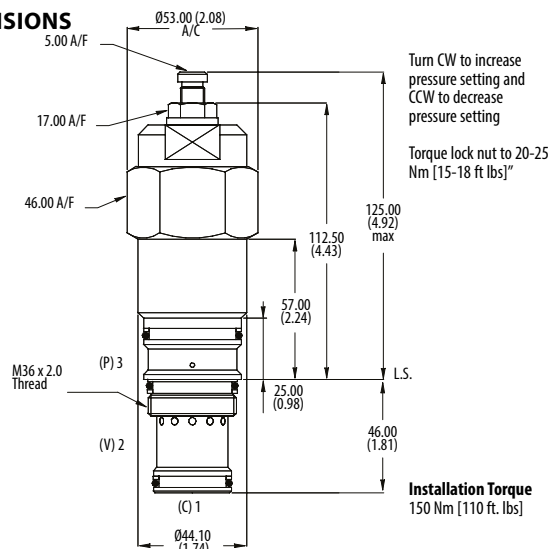

PERFORMANCE CURVES

Pressure Drop

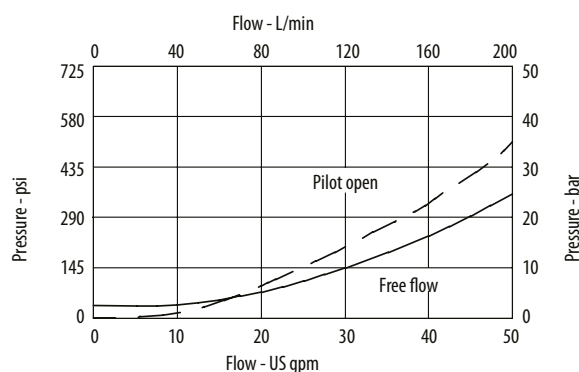

Motion Control Valves

1CPBD30

Overcenter Valve, Zero Differential, Poppet Type, External Drain, Port 3 Pilot

350 bar [5000 psi] • 30 l/min [8 US gpm]

DESCRIPTION AND OPERATION

This is a zero differential overcenter valve, which is a pilot assisted, metered poppet valve with an integral free flow check. The check section allows free flow from port 2 to 1 into the actuator then holds and locks the load in position. By applying pilot pressure on port 3, the valve will open allowing the load to be lowered with oil passing from port 1 to 2. With port 4 connected to tank back pressure will not affect the pilot pressure required to open the valve. These valves are usually used in conjunction with a remote pilot source to maintain control in the event of hose failure. They should always be mounted onto or into the actuator and they do not have a relief function.

SCHEMATIC

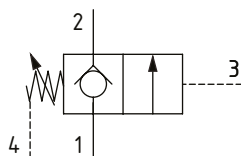

PERFORMANCE DATA

Rated pressure	350 bar [5000 psi]
Rated flow	30 l/min [8 US gpm]
Leakage	0.3 ml/min [5 drops/min]
Weight	0.15 kg [0.33 lb]
Cavity	A20530

MODEL CODE

1CPBD30 - F - 3W - 2 - P - 377 - 10

Basic Code

1CPBD30-No housing
1CPBD35-Cartridge and housing

Adjustment Option

F - External

Housing

Code	Ports	Aluminum	Steel
Omit	No housing		
3W	3/8" BSP Valve & Cyl. Port, 1/4" BSP Pilot and Vent Port	12007689	12007699
6T	#6 SAE Valve & Cyl. Port, #4 SAE Pilot and Vent Port	12007686	12007694

* Aluminum bodies are to be used for pressures less than 210 bar [3000 psi].

* Additional housings available

Pilot Pressure Range

Code	Bar	Psi
2	5-20	[73-290]
Standard Setting	10	[145]

Std setting made at 4.5 l/min

Pilot Pressure Setting

Code Pressure setting in bar (10 bar increments within specified Pressure Range)
XXX-Standard setting (see Pressure Range for value). Example:

Code	Bar	Psi
10	10	[145]

Housing Material

Omit - Aluminum/No Housing
377 - Steel

Seal Option

Code	Seal kit
S-Buna-N	SK1159
SV-Viton	SK1159V
P-Polyurethane/Buna-N	SK1159P

DIMENSIONS

mm [in]

Turn CW to increase pressure setting and CCW to decrease pressure setting

Torque lock nut to 20-25 Nm [15-18 ft lbs]

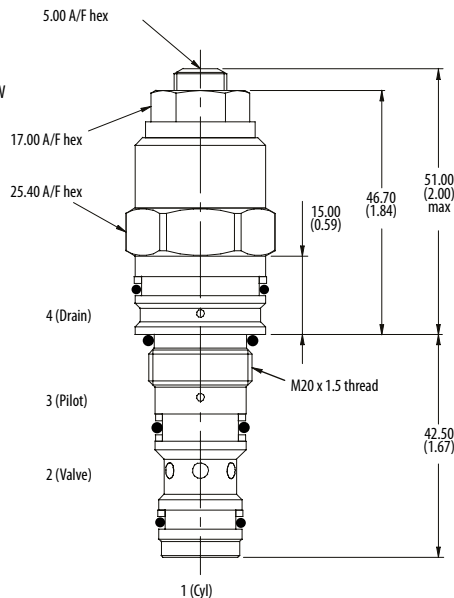

Installation Torque
45 Nm [33 ft. lbs]

PERFORMANCE CURVES

Pressure Drop

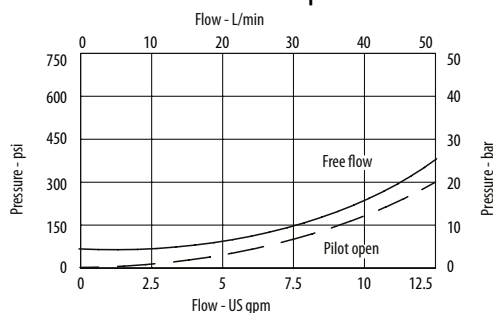

Motion Control Valves

1CPBD90

Overcenter Valve, Zero Differential, Poppet Type, External Drain, Port 3 Pilot

350 bar [5000 psi] • 90 l/min [24 US gpm]

DESCRIPTION AND OPERATION

This is a zero differential overcenter valve, which is a pilot assisted, metered poppet valve with an integral free flow check. The check section allows free flow from port 2 to 1 into the actuator then holds and locks the load in position. By applying pilot pressure on port 3, the valve will open allowing the load to be lowered with oil passing from port 1 to 2. With port 4 connected to tank back pressure will not affect the pilot pressure required to open the valve. These valves are usually used in conjunction with a remote pilot source to maintain control in the event of hose failure. They should always be mounted onto or into the actuator and they do not have a relief function.

SCHEMATIC

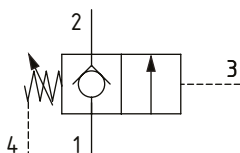

PERFORMANCE DATA

Rated pressure	350 bar [5000 psi]
Rated flow	90 l/min [24 US gpm]
Leakage	0.3 ml/min nominal [5 drops/min]
Weight	0.29 kg [0.63 lb]
Cavity	A12196

MODEL CODE

1CPBD90 - F - 4W - 2 - P - 377 - 10

Basic Code

1CPBD90 - No housing
1CPBD95 - Cartridge and housing

Adjustment Option

F - External

Housing

Code	Ports	Aluminum	Steel
Omit	No housing		
4W	1/2" BSP Valve & Cyl. Port, 1/4" BSP Pilot and Vent Port	B16357	B23615
8T	#8 SAE Valve & Cyl. Port, #4 SAE Pilot and Vent Port	12007706	12007708

* Aluminum bodies are to be used for pressures less than 210 bar [3000 psi].

* Additional housings available

Pilot Pressure Range

Code	Bar	Psi
2	5-20	[73-290]
Standard Setting	10	[145]

Std setting made at 4.5 l/min

Pilot Pressure Setting

Code Pressure setting in bar (10 bar increments within specified Pressure Range)
XXX-Standard setting (see Pressure Range for value). Example:

Code	Bar	Psi
10	10	[145]

Housing Material

Omit - Aluminum/No Housing
377 - Steel

Seal Option

Code	Seal kit
S-Buna-N	SK634
SV-Viton	SK634V
P-Polyurethane/Nitrile	SK634-P

DIMENSIONS

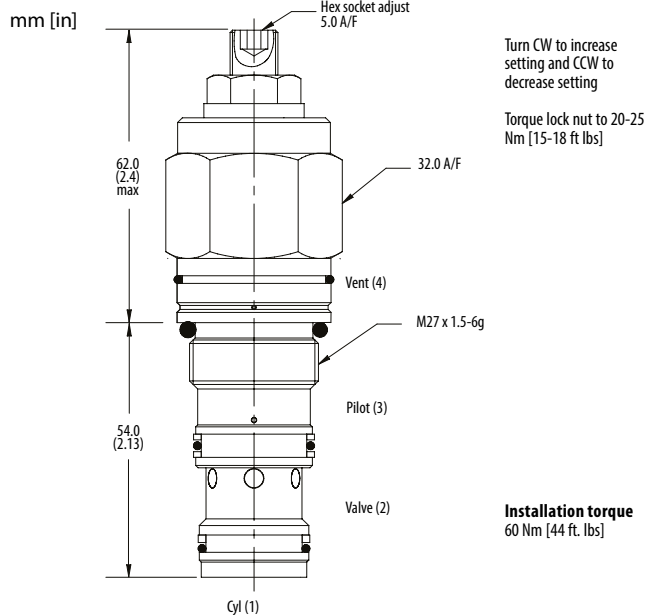

PERFORMANCE CURVES

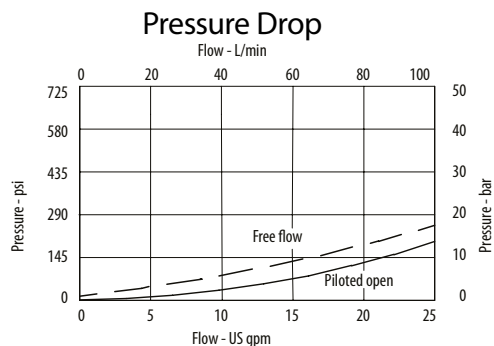

Motion Control Valves

1CPBD120

Overcenter Valve, Zero Differential, Poppet Type, External Drain, Port 3 Pilot

400 bar [5800 psi] • 180 l/min [47 US gpm]

DESCRIPTION AND OPERATION

This is a zero differential overcenter valve, which is a pilot assisted, metered poppet valve with an integral free flow check. The check section allows free flow from port 2 to 1 into the actuator then holds and locks the load in position. By applying pilot pressure on port 3, the valve will open allowing the load to be lowered with oil passing from port 1 to 2. With port 4 connected to tank back pressure will not affect the pilot pressure required to open the valve. These valves are usually used in conjunction with a remote pilot source to maintain control in the event of hose failure. They should always be mounted onto or into the actuator and they do not have a relief function.

SCHEMATIC

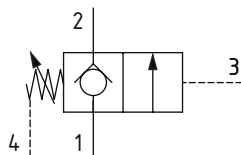

PERFORMANCE DATA

Rated pressure	400 bar [5800 psi]
Rated flow	180 l/min [47 US gpm]
Leakage	0.3 ml/min max [5 drops/min]
Weight	0.59 kg [1.30 lb]
Cavity	A6726

MODEL CODE

1CPBD120 - F - 6W - 2 - P - 377 - 10

Basic Code

1CPBD120 - No housing
1CPBD150 - Cartridge and housing

Adjustment Option

F - External

Housing

Code	Ports	Aluminum	Steel
Omit	No housing		
6W	3/4" BSP Valve & Cyl. Port, 1/4" BSP Pilot and Vent Port	12007710	12007715
12T	#12 SAE Valve & Cyl. Port, #4 SAE Pilot and Vent Port	12007709	12007712

* Aluminum bodies are to be used for pressures less than 210 bar [3000 psi].

* Additional housings available

Pilot Pressure Range

Code	Bar	Psi
2	5-20	[73-290]
Standard Setting	10	[145]

Std setting made at 4.5 l/min

Pilot Pressure Setting

Code Pressure setting in bar (2 bar increments within specified Pressure Range)

XXX - Standard setting (see Pressure Range for value). Example:

Code	Bar	Psi
10	10	[145]

Housing Material

Omit - Aluminum/No Housing
377 - Steel

Seal Option

Code	Seal kit
S-Buna-N	SK830
SV-Viton	SK830V
P-Polyurethane/Buna-N	SK830P

DIMENSIONS

mm [in]

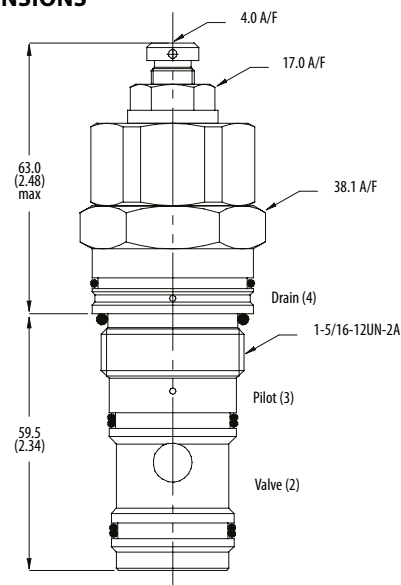

Turn CW to increase pressure setting and CCW to decrease pressure setting

Torque lock nut to 20-25 Nm [15-18 ft lbs]

Installation torque
100 Nm [74 ft. lbs]

PERFORMANCE CURVES

Pressure Drop

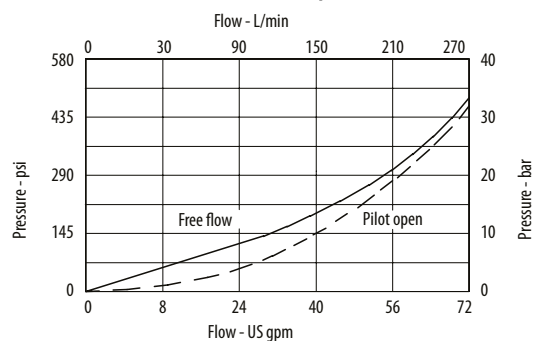

Motion Control Valves

1CPBD300

Overcenter Valve, Zero Differential, Poppet Type, External Drain, Port 3 Pilot

400 bar [5800 psi] • 300 l/min [80 US gpm]

DESCRIPTION AND OPERATION

This is a zero differential overcenter valve, which is a pilot assisted, metered poppet valve with an integral free flow check. The check section allows free flow from port 2 to 1 into the actuator then holds and locks the load in position. By applying pilot pressure on port 3, the valve will open allowing the load to be lowered with oil passing from port 1 to 2. With port 4 connected to tank back pressure will not affect the pilot pressure required to open the valve. These valves are usually used in conjunction with a remote pilot source to maintain control in the event of hose failure. They should always be mounted onto or into the actuator and they do not have a relief function.

SCHEMATIC

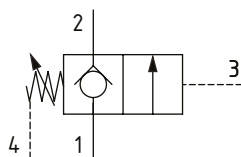

PERFORMANCE DATA

Rated pressure	400 bar [5800 psi]
Rated flow	300 l/min [80 US gpm]
Leakage	4 ml/min nominal [60 drops/min]
Weight	0.91 kg [2.00 lb]
Cavity	A13098

MODEL CODE

1CPBD300 - F - 10W - 2 - P - 377 - 10

Basic Code

1CPBD300 - No housing
1CPBD350 - Cartridge and housing

Adjustment Option

F - External

Housing

Code	Ports	Aluminum Steel	
Omit	No housing		
10W	1 1/4" BSP Valve & Cyl. Port, 1/4" BSP Pilot and Vent Port	12007720	12007722
20T	#20 SAE Valve & Cyl. Port, #4 SAE Pilot and Vent Port	12007719	12007721

* Aluminum bodies are to be used for pressures less than 210 bar [3000 psi].

Pilot Pressure Range

Code	Bar	Psi
2	5-20	[73-290]
Standard Setting	10	[145]

Std setting made at 4.5 l/min

Pilot Pressure Setting

Code Pressure setting in bar (10 bar increments within specified Pressure Range)
XXX - Standard setting (see Pressure Range for value)
Example:

Code	Bar	Psi
10	10	[145]

Housing Material

Omit - Aluminum/No Housing
377 - Steel

Seal Option

Code	Seal kit
S-Buna-N	SK971
SV-Viton	SK971V
P-Polyurethane/Buna-N	SK971P

DIMENSIONS

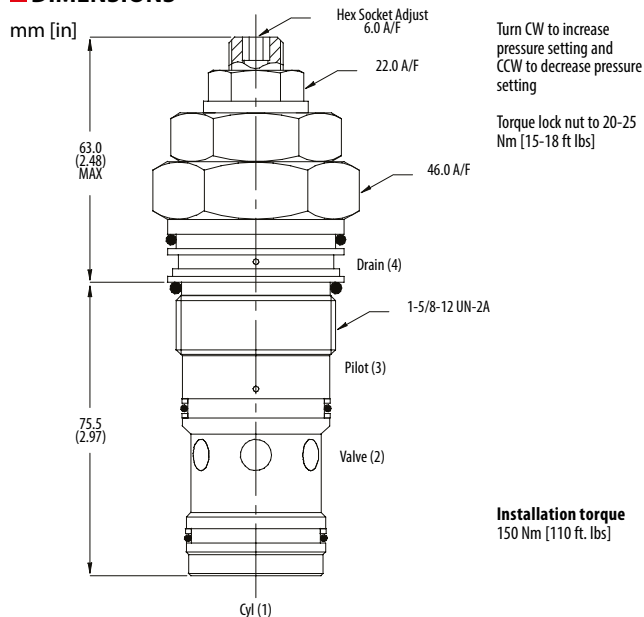

PERFORMANCE CURVES

Pressure Drop

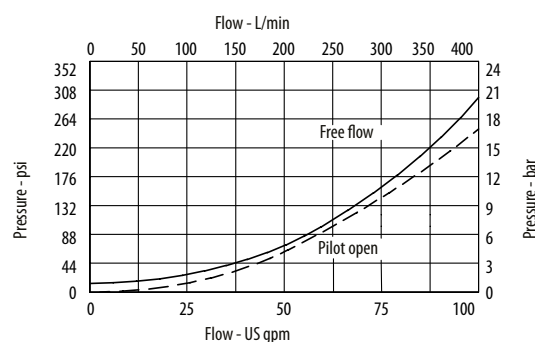

Motion Control Valves

1CPPD90

Zero Differential Valve, Normally Closed, Poppet Type, External Drain, Port 3 Pilot

350 bar [5000 psi] • 90 l/min [24 US gpm]

DESCRIPTION AND OPERATION

This is a normally closed zero differential valve, which is a pilot assisted metered, bi-directional poppet valve. By applying pilot pressure on port 3 the valve will open allowing the load to be lowered with oil passing from port 1 to 2 or port 2 to 1. With port 4 connected to tank, back pressure will not affect the pilot pressure required to open the valve. These valves are usually used in conjunction with a remote pilot source to maintain control in the event of hose failure. They should always be mounted on to or into the actuator. These valves do not have a relief function.

SCHEMATIC

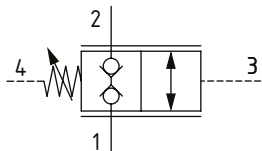

PERFORMANCE DATA

Rated pressure	350 bar [5000 psi]
Rated flow	90 l/min [24 US gpm]
Leakage	0.3 ml/min nominal [5 drops/min]
Weight	0.37 kg [0.82 lbs]
Cavity	A12196

MODEL CODE

1CPPD90 - F - 4W - 2 - P - 377 - 10

Basic Code

1CPPD90 - No housing
1CPPD95 - Cartridge and housing

Adjustment Option

F - External
G - Tamper resistant
N - Non-adjustable option, contact technical support

Housing

Code	Ports	Aluminum	Steel
Omit	No housing		
4W	1/2" BSP Valve & Cyl. Port, 1/4" BSP Pilot and Vent Port	B16357	B23615
8T	#8 SAE Valve & Cyl. Port, #4 SAE Pilot and Vent Port	12007706	12007708

* Aluminum bodies are to be used for pressures less than 210 bar [3000 psi].

Pilot Pressure Range

Code	Bar	Psi
2	8-25	[116-363]
Standard Setting	10	[145]

Std setting made at 4.5 l/min

Pilot Pressure Setting

Code Pressure setting in bar (2 bar increments within specified Pressure Range)
XXX - Standard setting (see Pressure Range for value)
Example:

Code	Bar	Psi
10	10	[145]

Housing Material

Omit - Aluminum/No Housing
377 - Steel

Seal Option

Code	Seal kit
S-Buna-N	SK1453
SV-Viton	SK1453V
P-Polyurethane/Buna-N	SK1453P

DIMENSIONS

mm [in]

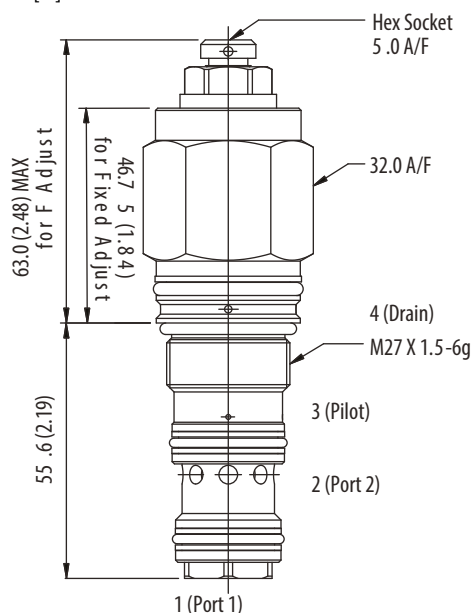

Turn CW to increase pressure setting and CCW to decrease pressure setting

Torque lock nut to 20-25 Nm [15-18 ft lbs]

Installation torque 60 Nm [44 ft. lbs]

PERFORMANCE CURVES

Pressure Drop

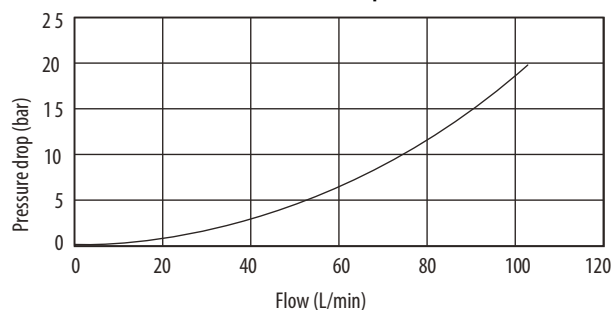

Motion Control Valves

1CEEC35

Dual Counterbalance Valve, Standard, Direct Acting with Makeup Checks

350 bar [5000 psi] • 30 l/min [8 US gpm]

DESCRIPTION AND OPERATION

This is a dual motion control and lock valve, with make-up check valves and cross line shock and thermal relief functions built into an HIC. Flow passes through a check valve from V1 to C1 to the actuator and returns through C2 to V2 or to T. Pilot pressure raised before the check valve in line V1 to C1 pilots open the overcenter valve on the outlet of the actuator, providing load control. In the reverse direction, flow passes through a check valve from V2 to C2 to the actuator and then through C1 to V1 or to T. Pilot pressure raised before the check valve in line V2 to C2 pilots open the overcenter valve on the outlet of the actuator providing load control. Check valves between T, V1 and V2 provide anti-cavitation protection.

SCHEMATIC

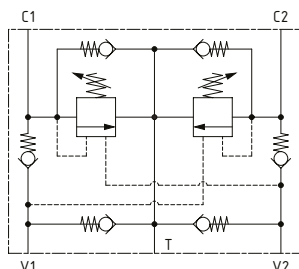

DIMENSIONS

mm [in]

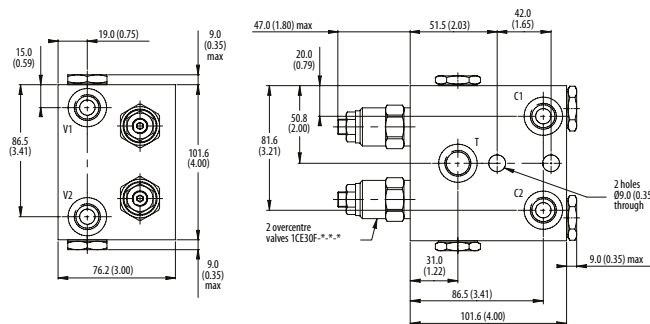

PERFORMANCE DATA

Rated pressure	350 bar [5000 psi]
Rated flow	30 l/min [8 US gpm]
Max total relief pressure	350 bar [5000 psi]
Max recommended pressure at max setting	270 bar [3900 psi]
Pilot Ratio	2.5:1, 5:1, 10:1
Leakage	0.3 ml/min nominal [5 drops/min]
Weight	2.03 kg [4.50 lb]

PERFORMANCE CURVES

Pressure Drop

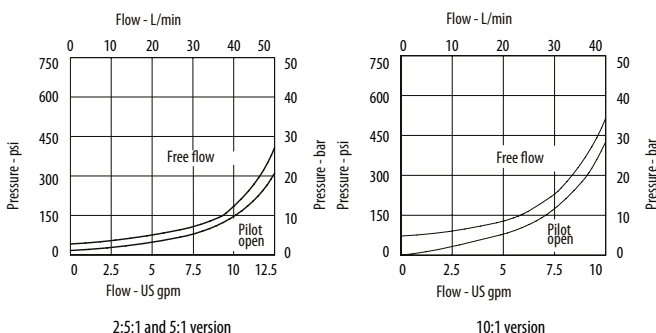

MODEL CODE

1CEEC35 - F - 3W - 35 - S - 5 - 377 - 210

Adjustment Option

F - External
N - Non-adjustable option, contact technical support

Housing

Code	Ports	Steel
3W	3/8" BSP	BXP16247-3WS377

Pressure Range

Code	Pilot Ratio 2		Pilot Ratio 5		Pilot Ratio 10	
	Bar	Psi	Bar	Psi	Bar	Psi
20	70-210	[1015-3000]	70-120	[1015-3000]	100-210	[1450-3000]
Standard setting	100	[1450]	100	[1450]	100	[1450]
35	100-350	[1450-5000]	100-350	[1450-5000]	120-350	[1740-5000]
Standard setting	210	[3000]	210	[3000]	210	[3000]

Std setting made at 4.5 l/min

Pressure Setting

Code x100 - Pressure setting in psi (10 psi increments within specified Pressure Range)
XXX - Standard setting (see Pressure Range for value)
 Example:

Code	Bar	Psi
210	210	[3000]

Housing Material

377 - Steel

Pilot Ratio

2 - 2.5:1
5 - 5:1
10 - 10:1

Seal Option

Code	Seal kit
S - Buna-N	SK815
SV - Viton	SK815V

Motion Control Valves

1CEEC95

Dual Counterbalance Valve, Standard, Direct Acting with Makeup Checks

350 bar [5000 psi] • 90 l/min [24 US gpm]

DESCRIPTION AND OPERATION

This is a dual motion control and lock valve, with make-up check valves and cross line shock and thermal relief functions built into an HIC. Flow passes through a check valve from V1 to C1 to the actuator and returns through C2 to V2 or to T. Pilot pressure raised before the check valve in line V1 to C1 pilots open the overcenter valve on the outlet of the actuator, providing load control. In the reverse direction, flow passes through a check valve from V2 to C2 to the actuator and then through C1 to V1 or to T. Pilot pressure raised before the check valve in line V2 to C2 pilots open the overcenter valve on the outlet of the actuator providing load control. Check valves between T, V1 and V2 provide anti-cavitation protection.

SCHEMATIC

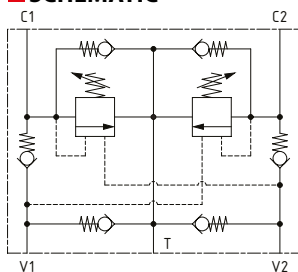

PERFORMANCE DATA

Rated pressure	350 bar [5000 psi]
Rated flow	90 l/min [24 US gpm]
Max total relief pressure	350 bar [5000 psi]
Max recommended load pressure at max setting	270 bar [3900 psi]
Pilot Ratio	4:1, 8:1
Leakage	0.3 ml/min nominal [5 drops/min]
Weight	3.70 kg [8.20 lb]

PERFORMANCE CURVES

Pressure Drop

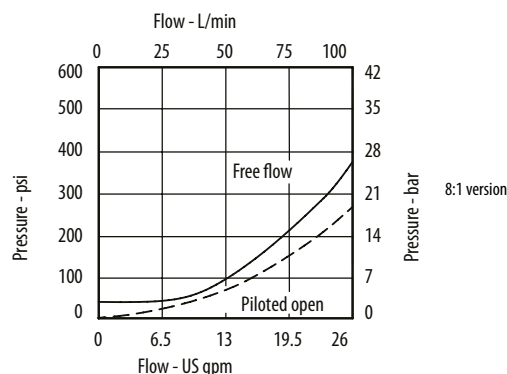
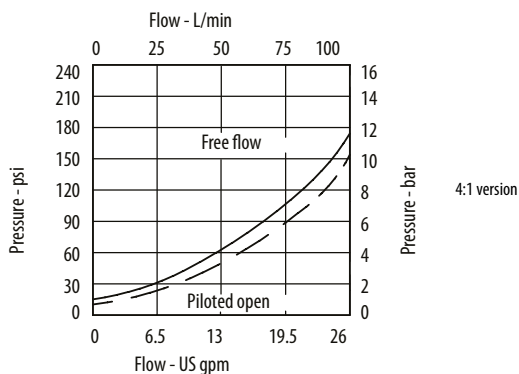

MODEL CODE

1CEEC95 - F - 6W - 35 - S - 4 - 377 - 210

Adjustment Option

F - External
N - Non-adjustable option, contact technical support

Housing

Code	Ports	Steel
6W	3/4" BSP	BXP16248-6WS377

Pressure Range

Code	Bar	Psi
20	70-225	[1015-3260]
Standard Setting	100	[1450]
35	200-350	[2900-5000]
Standard Setting	210	[3000]

Std setting made at 4.5 L/min

Pressure Setting

Code Pressure setting in bar (10 bar increments within specified Pressure Range)
XXX - Standard setting (see Pressure Range for value)
Example:

Code	Bar	Psi
210	210	[3000]

Housing Material

377 - Steel

Pilot Ratio

4 - 4:1
8 - 8:1

Seal Option

Code	Seal kit
S-Buna-N	SK814
SV-Viton	SK814V

DIMENSIONS

mm [in]

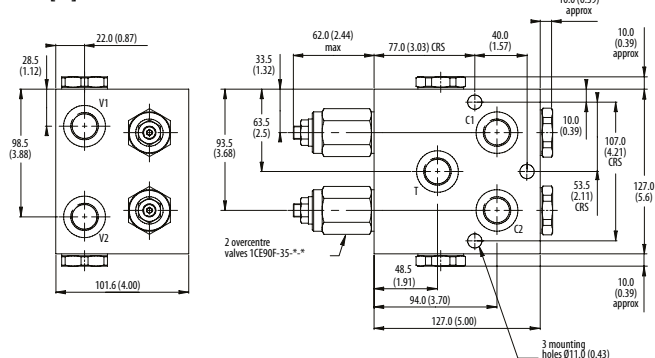

Motion Control Valves

1CEEC150

Dual Counterbalance Valve, Standard, Differential Area with Makeup Checks

350 bar [5000 psi] • 120 l/min [32 US gpm]

DESCRIPTION AND OPERATION

This is a dual motion control and lock valve, with make-up check valves and cross line shock and thermal relief functions built into an HIC. Flow passes through a check valve from V1 to C1 to the actuator and returns through C2 to V2 or to T. Pilot pressure raised before the check valve in line V1 to C1 pilots open the overcenter valve on the outlet of the actuator, providing load control. In the reverse direction, flow passes through a check valve from V2 to C2 to the actuator and then through C1 to V1 or to T. Pilot pressure raised before the check valve in line V2 to C2 pilots open the overcenter valve on the outlet of the actuator providing load control. Check valves between T, V1 and V2 provide anti-cavitation protection.

SCHEMATIC

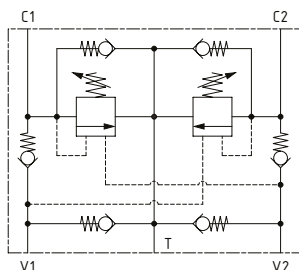

DIMENSIONS

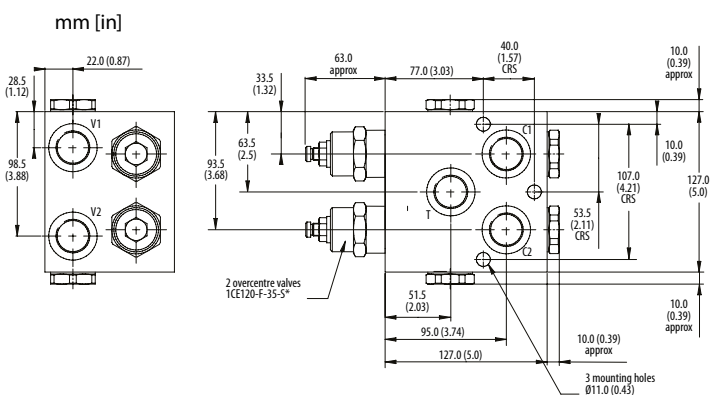

PERFORMANCE DATA

Rated pressure	350 bar [5000 psi]
Rated flow	120 l/min [32 US gpm]
Max total relief pressure	350 bar [5000 psi]
Max recommended load pressure at max setting	270 bar [3900 psi]
Pilot Ratio	3.5:1, 8:1
Leakage	0.3 ml/min [5 drops/min]
Weight	3.70 kg [8.20 lb]

PERFORMANCE CURVES

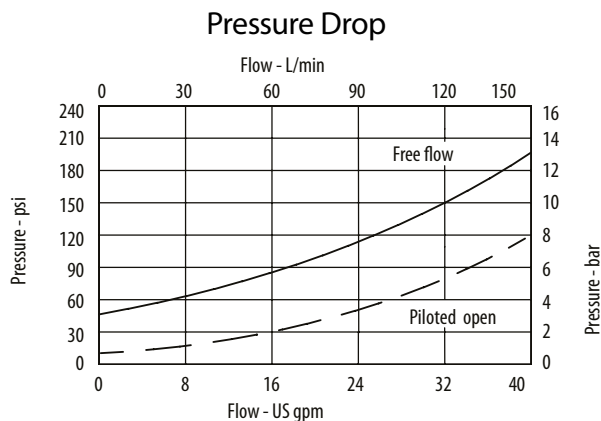

MODEL CODE

1CEEC150 - F - 8W - 35 - S - 3 - 377 - 210

Adjustment Option

F - External

Housing

Code	Ports	Steel
8W	1" BSP Valve & Cyl Port. 1/4" BSP Brake Port	BXP15687-8WS377

Pressure Range

Code	Bar	Psi
35	70-350	[1015-5000]
Standard Setting	210	[3000]

Std setting made at 4.5 l/min

Pressure Setting

Code Pressure setting in bar (10 bar increments within specified Pressure Range)
XXX-Standard setting (see Pressure Range for value)
Example:

Code	Bar	Psi
210	210	[3000]

Housing Material

377 - Steel

Pilot Ratio

3 - 3.5:1
8 - 8:1

Seal Option

Code	Seal kit
S-Buna-N	SK813
SV-Viton	SK813V

Motion Control Valves

1CEEC350

Dual Counterbalance Valve, Standard, Differential Area with Makeup Checks

350 bar [5000 psi] • 300 l/min [80 US gpm]

DESCRIPTION AND OPERATION

This is a dual motion control and lock valve, with make-up check valves and cross line shock and thermal relief functions built into an HIC. Flow passes through a check valve from V1 to C1 to the actuator and returns through C2 to V2 or to T. Pilot pressure raised before the check valve in line V1 to C1 pilots open the overcenter valve on the outlet of the actuator, providing load control. In the reverse direction, flow passes through a check valve from V2 to C2 to the actuator and then through C1 to V1 or to T. Pilot pressure raised before the check valve in line V2 to C2 pilots open the overcenter valve on the outlet of the actuator providing load control. Check valves between T, V1 and V2 provide anti-cavitation protection.

SCHEMATIC

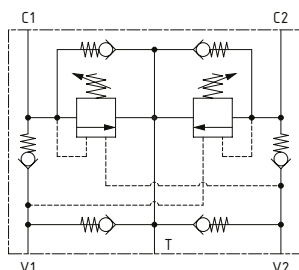

DIMENSIONS

mm [in]

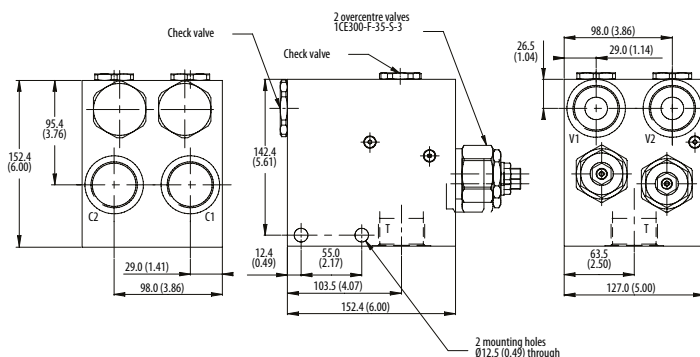

PERFORMANCE DATA

Rated pressure	350 bar [5000 psi]
Rated flow	300 l/min [80 US gpm]
Max total relief pressure	350 bar [5000 psi]
Max recommended load pressure at max setting	270 bar [3900 psi]
Pilot Ratio	3:1, 8:1
Leakage	4 ml/min [60 drops/min]
Weight	8.2 kg [18.0 lb]

PERFORMANCE CURVES

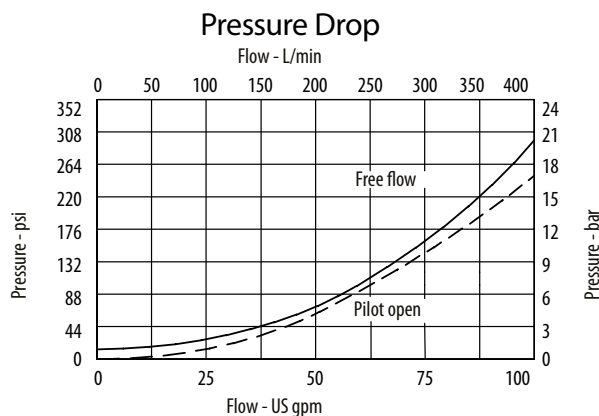

MODEL CODE

1CEEC350 - F - 10W - 35 - S - 3 - 377 - 210

Adjustment Option

F - External

Housing

Code	Ports	Steel
10W	1 1/4" BSP valve & cyl port. 1/4" BSP brake port	DXP16844-10WS377

Pressure Range

Code	Bar	Psi
35	70-350	[1015-5000]
Standard Setting	210	[3000]

Std setting made at 4.5 l/min

Seal Option

Code	Seal kit
S-Buna-N	SK635
SV-Viton	SK635V

Pressure Setting

Code Pressure setting in bar (10 bar increments within specified Pressure Range)
XXX-Standard setting (see Pressure Range for value)
Example:

Code	Bar	Psi
210	210	[3000]

Housing Material

377 - Steel

Pilot Ratio

3 - 3:1
8 - 8:1

Motion Control Valves

1CEESH35

Dual Counterbalance Valve, Standard, Direct Acting with Makeup Checks and Shuttle Valve

350 bar [5000 psi] • 30 l/min [8 US gpm]

DESCRIPTION AND OPERATION

This is a dual motion control and lock valve with a shuttle valve, make up check valves and cross line shock and thermal relief functions built into an HIC. Flow passes through a check valve from V1 to C1 to the actuator and returns through C2 to V2 or T. Pilot pressure raised before the check valve in line V1 to C1 pilots open the overcenter valve on the outlet of the actuator, providing load control. In the reverse direction, flow passes through a check valve from V2 to C2 to the actuator and returns through C1 to V1 or to T. Pilot pressure raised before the check valve in line V2 to C2 pilots open the overcenter valve on the outlet of the actuator, providing load control. Check valves between T, V1 and V2 provide anti-cavitation protection. A shuttle valve is provided between ports V1 and V2 to provide pressure to remove a spring applied brake.

SCHEMATIC

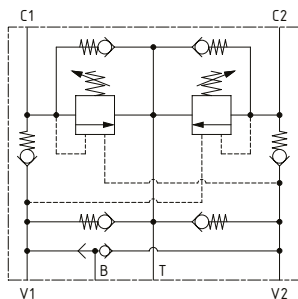

DIMENSIONS

mm [in]

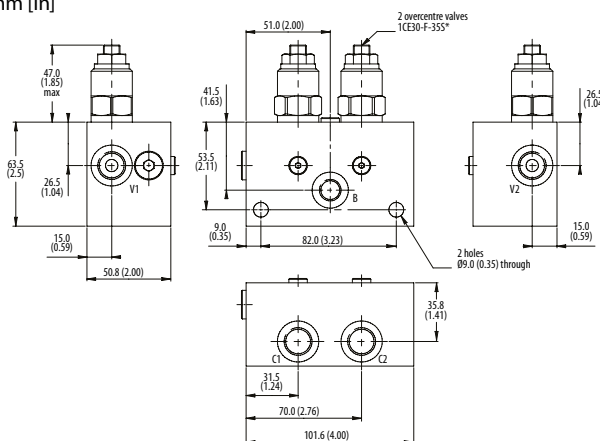

PERFORMANCE DATA

Rated pressure	350 bar [5000 psi]
Rated flow	30 l/min [8 US gpm]
Max total relief pressure	350 bar [5000 psi]
Max recommended load pressure at max setting	270 bar [3900 psi]
Pilot Ratio	2.5:1, 5:1, 10:1
Leakage	0.3 ml/min [5 drops/min]
Weight	2.03 kg [4.5 lb]

PERFORMANCE CURVES

Pressure Drop

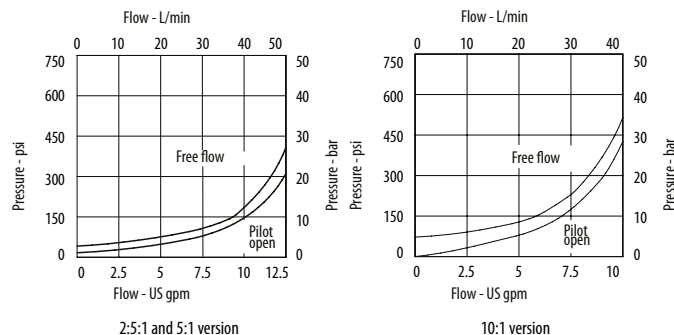

MODEL CODE

1CEESH35 - F - 3W - 35 - S - 5 - 377 - 210

Adjustment Option

F - External
N - Non-adjustable option, contact technical support

Housing

Code	Ports	Steel single
3W	3/4" BSP Valve & Cyl Port 1/4" BSP Brake Port	BXP15939-3WS377

Pressure Range

Code	Pilot Ratio 2		Pilot Ratio 5		Pilot Ratio 10	
	Bar	Psi	Bar	Psi	Bar	Psi
20	70-210	[1015-3000]	70-120	[1015-3000]	100-210	[1450-3000]
Standard setting	100	[1450]	100	[1450]	100	[1450]
35	100-350	[1450-5000]	100-350	[1450-5000]	120-350	[1740-5000]
Standard setting	210	[3000]	210	[3000]	210	[3000]

Std setting made at 4.5 l/min

Pressure Setting

Code Pressure setting in bar (10 bar increments within specified Pressure Range)
XXX-Standard setting (see Pressure Range for value)
Example:

Code	Bar	Psi
210	210	[3000]

Housing Material

377 - Steel

Pilot Ratio

2 - 2.5:1
5 - 5:1
10 - 10:1

Seal Option

Code	Seal kit
S-Buna-N	SK815
SV-Viton	SK815V

Motion Control Valves

1CEESH95

Dual Counterbalance Valve, Standard, Direct Acting with Makeup Checks and Shuttle Valve

350 bar [5000 psi] • 90 l/min [24 US gpm]

DESCRIPTION AND OPERATION

This is a dual motion control and lock valve with a shuttle valve, make up check valves and cross line shock and thermal relief functions built into an HIC. Flow passes through a check valve from V1 to C1 to the actuator and returns through C2 to V2 or to T. Pilot pressure raised before the check valve in line V1 to C1 pilots open the overcenter valve on the outlet of the actuator, providing load control. In the reverse direction, flow passes through a check valve from V2 to C2 to the actuator and returns through C1 to V1 or to T. Pilot pressure raised before the check valve in line V2 to C2 pilots open the overcenter valve on the outlet of the actuator, providing load control. Check valves between T, V1 and V2 provide anti-cavitation protection. A shuttle valve is provided between ports V1 and V2 to provide pressure to remove a spring applied brake.

SCHEMATIC

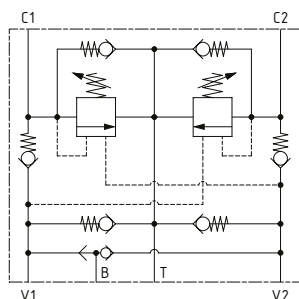

DIMENSIONS

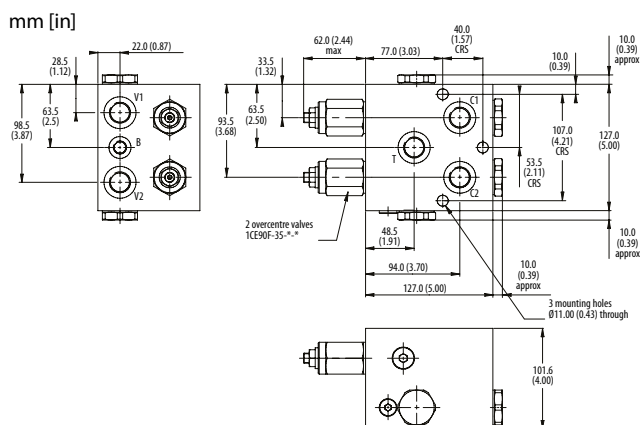

PERFORMANCE DATA

Rated pressure	350 bar [5000 psi]
Rated flow	90 l/min [24 US gpm]
Max total relief pressure	350 bar [5000 psi]
Max recommended load pressure at max setting	270 bar [3900 psi]
Pilot Ratio	4:1, 8:1
Leakage	0.3 ml/min [5 drops/min]
Weight	3.70 kg [8.20 lb]

PERFORMANCE CURVES

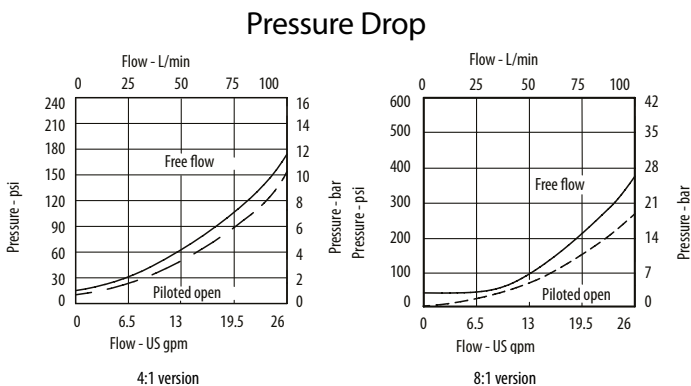

MODEL CODE

1CEESH95 - F - 6W - 35 - S - 4 - 377 - 210

Adjustment Option

F - External
N - Non-adjustable option, contact technical support

Housing

Code	Ports	Steel
6W	3/4" BSP Valve & Cyl Port. 1/4" BSP Brake Port	BXP15936-6WS377

Pressure Range

Code	Bar	Psi
20	70-225	[1015-3260]
Standard Setting	100	[1450]
35	200-350	[2900-5000]
Standard Setting	210	[3000]

Std setting made at 4.5 l/min

Seal Option

Code	Seal kit
S -Buna-N	SK814
SV -Viton	SK814V

Pressure Setting

Code Pressure setting in bar (10 bar increments within specified Pressure Range)
XXX-Standard setting (see Pressure Range for value)
 Example:

Code	Bar	Psi
210	210	[3000]

Housing Material

377 - Steel

Pilot Ratio

4 - 4:1
8 - 8:1

Motion Control Valves

1CEESH150

Dual Counterbalance Valve, Standard, Differential Area with Makeup Checks and Shuttle Valve

350 bar [5000 psi] • 120 l/min [32 US gpm]

DESCRIPTION AND OPERATION

This is a dual motion control and lock valve with a shuttle valve, make up check valves and cross line shock and thermal relief functions built into an HIC. Flow passes through a check valve from V1 to C1 to the actuator and returns through C2 to V2 or to T. Pilot pressure raised before the check valve in line V1 to C1 pilots open the overcenter valve on the outlet of the actuator, providing load control. In the reverse direction, flow passes through a check valve from V2 to C2 to the actuator and returns through C1 to V1 or to T. Pilot pressure raised before the check valve in line V2 to C2 pilots open the overcenter valve on the outlet of the actuator, providing load control. Check valves between T, V1 and V2 provide anti-cavitation protection. A shuttle valve is provided between ports V1 and V2 to provide pressure to remove a spring applied brake.

SCHEMATIC

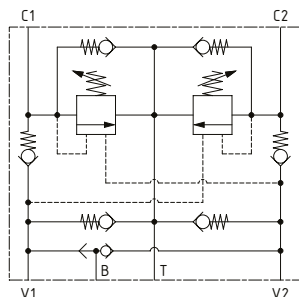

DIMENSIONS

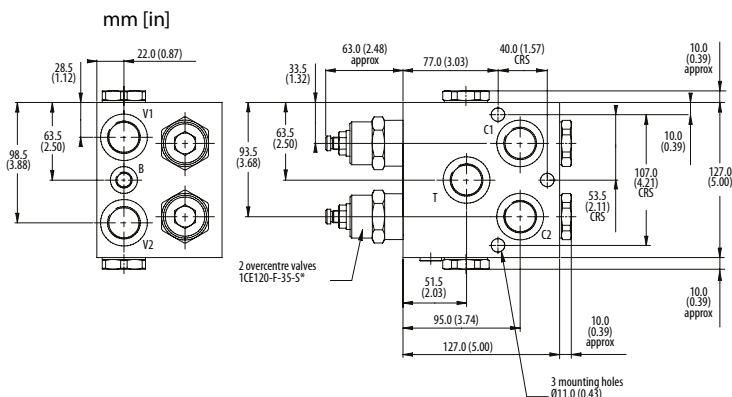

PERFORMANCE DATA

Rated pressure	350 bar [5000 psi]
Rated flow	120 l/min [32 US gpm]
Max total relief pressure	350 bar [5000 psi]
Max recommended load pressure at max setting	270 bar [3900 psi]
Pilot Ratio	3.5:1, 8:1
Leakage	0.3 ml/min [5 drops/min]
Weight	3.70 kg [8.20 lb]

PERFORMANCE CURVES

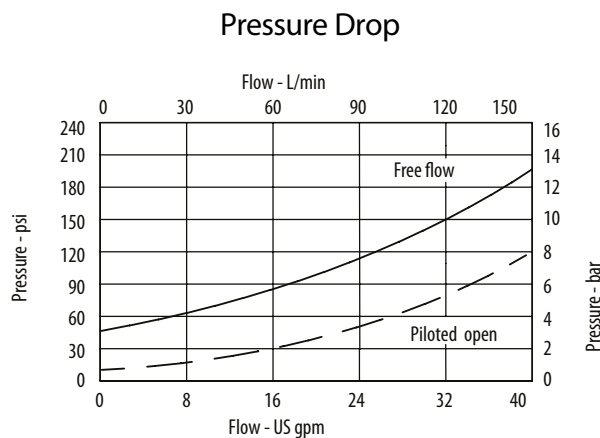

MODEL CODE

1CEESH150 - F - 8W - 35 - S - 3 - 377 - 210

Adjustment Option

F - External

Housing

Code	Ports	Steel
8W	1" BSP valve & cyl port. 1/4" BSP brake port	BXP15930-8WS377

Pressure Range

Code	Bar	Psi
35	70-350	[3015-5000]
Standard Setting	210	[3000]

Std. setting made at 4.5 l/min

Seal Option

Code	Seal kit
S-Buna-N	SK813
SV-Viton	SK813V

Pressure Setting

Code Pressure setting in bar (10 bar increments within specified Pressure Range)
 XXX-Standard setting (see Pressure Range for value)
 Example:

Code	Bar	Psi
210	210	[3000]

Housing Material

377 - Steel

Pilot Ratio

3 - 3.5:1
 8 - 8:1

Motion Control Valves

1CEESH350

Dual Counterbalance Valve, Standard, Differential Area with Makeup Checks and Shuttle Valve

350 bar [5000 psi] • 300 l/min [80 US gpm]

DESCRIPTION AND OPERATION

This is a dual motion control and lock valve with a shuttle valve, make up check valves and cross line shock and thermal relief functions built into an HIC. Flow passes through a check valve from V1 to C1 to the actuator and returns through C2 to V2 or T. Pilot pressure raised before the check valve in line V1 to C1 pilots open the overcenter valve on the outlet of the actuator, providing load control. In the reverse direction, flow passes through a check valve from V2 to C2 to the actuator and returns through C1 to V1 or to T. Pilot pressure raised before the check valve in line V2 to C2 pilots open the overcenter valve on the outlet of the actuator, providing load control. Check valves between T, V1 and V2 provide anti-cavitation protection. A shuttle valve is provided between ports V1 and V2 to provide pressure to remove a spring applied brake.

SCHEMATIC

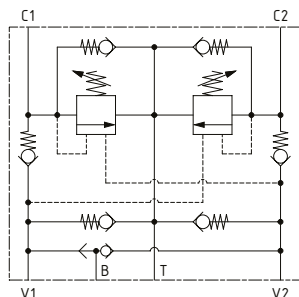

DIMENSIONS

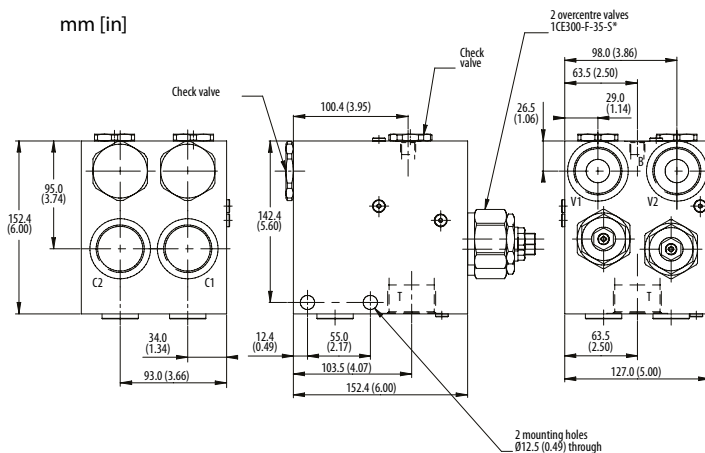

PERFORMANCE DATA

Rated pressure	350 bar [5000 psi]
Rated flow	300 l/min [80 US gpm]
Max total relief pressure	350 bar [5000 psi]
Max recommended load pressure at max setting	270 bar [3900 psi]
Pilot Ratio	3:1, 8:1
Leakage	4 ml/min [60 drops/min]
Weight	8.2 kg [18.0 lb]

PERFORMANCE CURVES

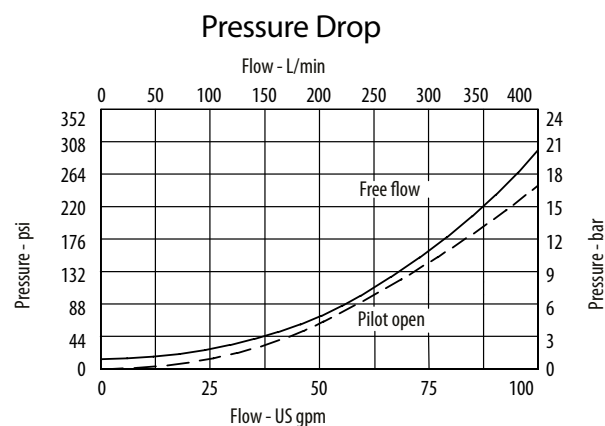

MODEL CODE

1CEESH350 - F - 10W - 35 - S - 3 - 377 - 210

Adjustment Option

F - External

Housing

Code	Ports	Steel
10W	1 1/4" BSP valve & cyl port. 1/4" BSP brake port	DXP22047-10WS377

Pressure Range

Code	Bar	Psi
35	70-350	[3015-5000]
Standard Setting	210	[3000]

Std setting made at 4.5 l/min

Seal Option

Code	Seal kit
S-Buna-N	SK635
SV-Viton	SK635V

Pressure Setting

Code Pressure setting in bar (10 bar increments within specified Pressure Range)
XXX-Standard setting (see Pressure Range for value)
Example:

Code	Bar	Psi
210	210	[3000]

Housing Material

377 - Steel

Pilot Ratio

3 - 3:1
8 - 8:1

Danfoss