

PV

Proportional Valves



Danfoss

Proportional Valves

Application Notes

Basic Operation: Solenoid Valves

A proportional valve, or electro-proportional valve, controls pressure or flow in response to a change in current applied to the coil used to activate the valve.

There are 4 basic functions provided by proportional valves:

- **Directional control** - 2, 3, 4 and 5 ported valves where the oil can be diverted or directed within the circuit to control the motion of an actuator. They can include load sense ports to signal a pump or a compensator to react when the system demands it.
- **Flow control** - 2 and 3 ported valves function as an infinitely adjustable orifice. They are available as non-compensated or with an integrated compensator to provide restrictive (2 port) or priority (3 port) flow control functions in a single cartridge.
- **Pressure relieving** - Relief valves where the pressure setting is adjusted proportionally with the electrical input signal. They are available as pilot valves or as pilot operated valves in a single cartridge in both normally closed and normally open configurations.
- **Pressure reducing** - Valves where the downstream pressure is controlled proportionally with the electrical input signal. They are available with or without reverse relief functionality.

4-Way, 3-Position Proportional Directional Control Valves

4-way, 3-position proportional directional valves control the direction of the flow within a system, opening proportionally based on the electrical input signal. They are available with all ports closed and motor spool center positions, where the outlet ports 2 and 4 are connected to tank, port 1.

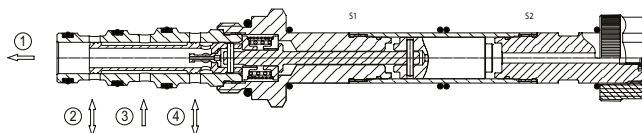
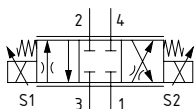

5-Way, 3-Position Proportional Directional Control Valves

5-way, 3-position proportional directional valves control the direction of the flow within a system, opening proportionally based on the electrical input signal. They offer load sense at port 1, which sends a signal to a pump or compensator to react when flow is required. In the center position (de-energized), the outlet ports 2 and 4 are connected to tank port 3 and the load sense port 1 is blocked. These are also available with an integral check valve on the load sense port.

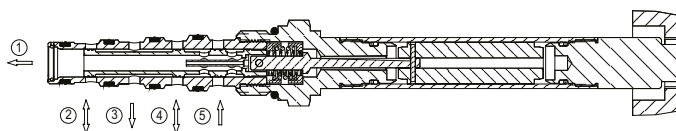
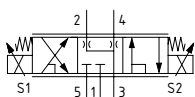

Proportional Poppet Type Flow Control Valves (Non-Compensated)

Proportional poppet type flow control valves are non-compensated, 2-position, 2-way normally open or closed valves. They provide an infinitely variable orifice with a load holding function when in the closed position. The outlet flow depends on the pressure differential across the valve and the opening area between the poppet and the seat. For optimal performance, these should be applied with a compensator to control the pressure differential across valve.

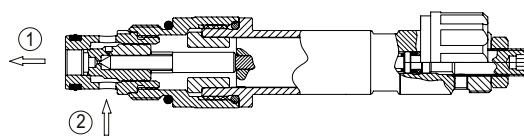
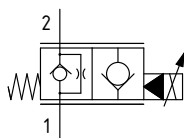
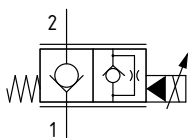

Proportional Valves

Application Notes

Proportional Spool Type Flow Control Valves (Non-Compensated)

Proportional spool type flow control valves are non-compensated, 2-position, 2-way normally open or closed valves. They provide an infinitely variable orifice and the outlet flow depends on the pressure differential across the valve and the opening created by the spool and the cross holes in the sleeve. For optimal performance, these should be applied with a compensator to control the pressure differential across valve.

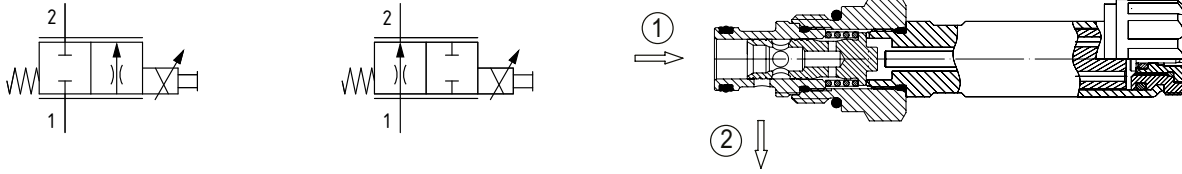

Proportional Double Blocking Poppet Type Flow Control Valves (Non-Compensated)

Double blocking proportional poppet type flow control valves are 2-position, 2-ported normally closed bi-directional valves. These provide an infinitely variable orifice when opened and a load holding function when in the closed position. The outlet flow depends on the pressure differential across the valve and the opening area between the poppet and the seat. These valves are ideal for load lowering applications on boom or scissor lifts.

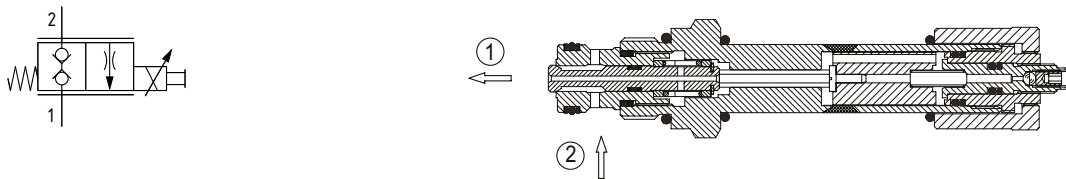

Proportional Pressure Compensated Restrictive Type Flow Control Valves

These are 2-way electro proportionally adjusted restrictive-type flow regulators, which are available in normally open or normally closed configurations. The valve consists of an infinitely variable control orifice in conjunction with a compensating spool. They provide controlled flow that can be varied with input current, which remains constant regardless of the pressure difference between the inlet and the outlet pressure.

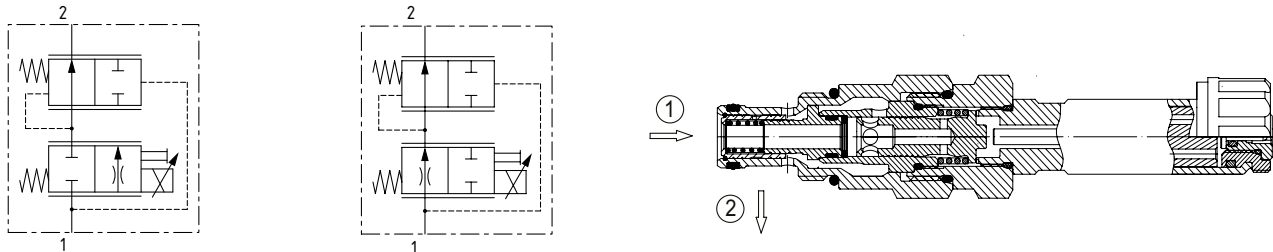

Proportional Pressure Compensated Restrictive Type Flow Control Valves

These are 3 ported electro proportionally adjusted Priority type flow regulators, which are available in normally open or normally closed configurations. The valve consists of an infinitely variable orifice that operates in conjunction with a compensating spool. They provide priority, controlled flow that can be varied with input current, while the excess flow passes through the bypass port. The priority flow remains constant regardless of changes in pressure across the valve or the bypass pressure being higher or lower than the priority pressure.

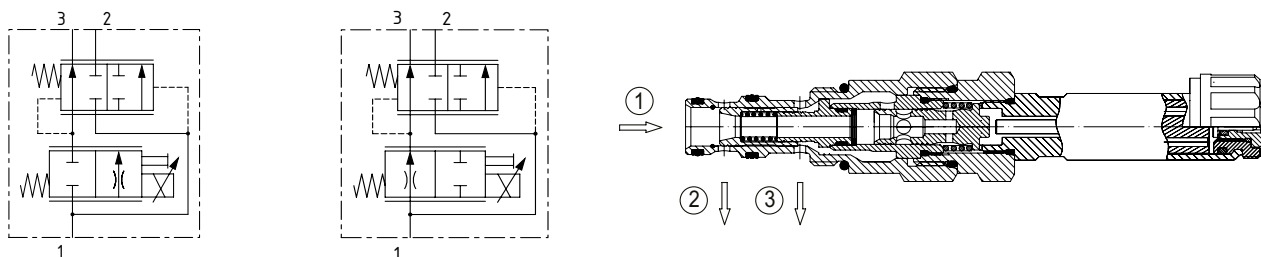

Proportional Valves

Application Notes

Proportional Direct Acting Pressure Relief Valves

These are low flow, electro proportionally adjusted pressure relief valves that are available in normally open or closed configurations. They are typically used in conjunction with higher flow valves, such as logic elements, to create a high flow relief. Normally open valves will relieve at minimum pressure when de-energized, and the pressure setting will increase as the input current is increased. Normally closed valves will relieve at a pre-set value when de-energized, and the pressure setting will decrease as the input current is increased. These are ideal for applications such as cooling fan drives, where the fan needs to be at full speed if there is a power failure or a problem with a coil.

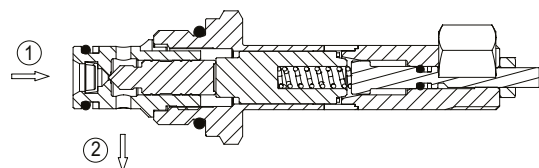
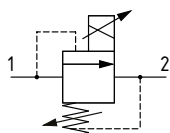

Proportional Pilot Operated Pressure Relief Valves

These are pilot operated, electro proportionally adjusted pressure relief valves that are available in normally open or closed configurations. Normally open valves will relieve at minimum pressure when de-energized, and the pressure setting will increase as the input current is increased. Normally closed valves will relieve at a pre-set value when de-energized, and the pressure setting will decrease as the input current is increased. These are ideal for applications such as cooling fan drives, where the fan needs to be at full speed if there is a power failure or a problem with a coil.

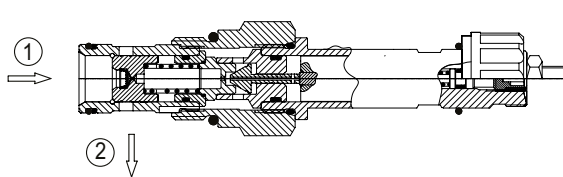
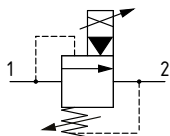

Proportional Direct Acting Pressure Reducing / Relieving Valves

These are 2-way electro proportionally adjusted restrictive-type flow regulators, which are available in normally open or normally closed configurations. The valve consists of an infinitely variable control orifice in conjunction with a compensating spool. They provide controlled flow that can be varied with input current, which remains constant regardless of the pressure difference between the inlet and the outlet pressure.

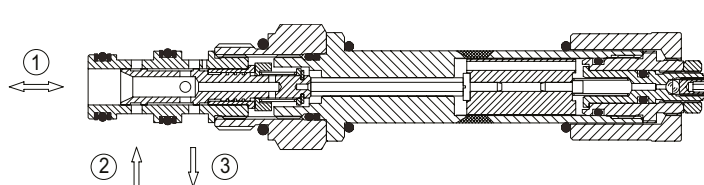
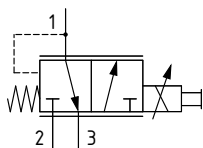

Proportional Pilot Operated Pressure Reducing / Relieving Valves

These are pilot operated, electro proportionally adjusted, pressure reducing valves with a reverse relief function. When the outlet pressure reaches the pressure setting, the valve restricts flow from the inlet (port 2). If, through external influence, the regulated pressure (port 1) should rise, the valve will relieve the excess flow to tank (port 3). These valves are available with the max setting at max current or inverse with the max setting at zero current. The proportional adjustment of these valves by an electrical signal allows for remote control of the outlet pressure in line with smooth operation of any actuator.

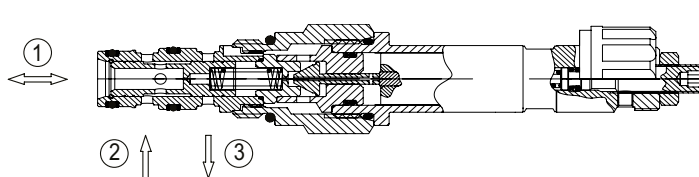
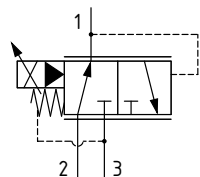

Proportional Valves

Application Notes

Application Recommendations

- All Danfoss cartridge proportional valves are analog-type valves that control flow or pressure related to an electrical input.
- These valves should be controlled using current, as the force or movement created within the valve is proportional to the current. If voltage control is applied, a temperature increase in the coil will reduce the current as the resistance increases, directly impacting the output of the valve.
- In general, a current based controller supply using PWM (Pulse Width Modulation) of 100-200Hz is recommended to reduce hysteresis and improve control. Refer to each product page for specific recommendations.
- Many of the valves can be used with a separate mainstage or compensator element. This increases the maximum flow to which you can apply these valves.

TERMS AND DEFINITIONS

- **Compensator** is a hydraulic component that maintains a constant pressure drop across a fixed or variable orifice.
- **Current** is the flow of electricity through a conductor or coil, normally measured in amp (A) Steady-state current flow in an electrical circuit can be calculated by Ohm's Law, as well as voltage and resistance.
Ohm's Law $I=V/R$
- **Current Control** is a feature of almost all valve drivers. The output of analogue proportional valves is a direct function of current. If a valve is controlled with voltage, higher solenoid temperatures, which increase solenoid resistance, will result in lower valve output. To compensate for this, most valve drivers are designed with current feedback circuitry. This means that as solenoid temperature rises or as supply voltage losses change, the current and corresponding valve output are Current maintained.
- **Deadband** is the range from zero to the minimum current which causes the valve Input to respond.
- **Digital Proportional Valves** are extremely fast responding valves that are controlled by a precise on-off signal to produce an average output that is a function of duty cycle.
- **Dither** is a "ripple" signal sent to a solenoid to reduce hysteresis. Dither can be a sine, square, or saw-tooth wave superimposed on a PWM signal or it can be a wave on top of a DC signal.
- **Duty Cycle** is the % of time the valve is on divided by total time.
- **Hysteresis** is the difference in output for a given input, depending on whether the input is increasing or decreasing. It is normally expressed as a % of the maximum rated output. For example, if a 160 l/min 42 US gal/min proportional flow control valve provides 80 l/min 21 US gal/min with 1 amp-increasing and 88 l/min 23 US gal/min at 1 amp-decreasing, the hysteresis is:
 $(88.80)/160=5\%$
- **I min** is the minimum current required for valve response (see deadband).
- **I max** is the current required for maximum valve output.
- **PWM** is an acronym for Pulse-Width-Modulation. Most valve drivers use a current controlled PWM which produces an average output that is a function of duty cycle in order to reduce valve hysteresis and to allow current control without excessive heat generation. A typical PWM output is a square wave from 80-500 Hz.
- **Ramping** is the application of current to a solenoid with a linear or non-linear ramp, rather than an instantaneous step. Ramping current on and off to a proportional valve provides actuators with soft-starts and soft-stops. Ramps can generally be set or pre-programmed into valve drivers
- **Resistance** is a component's opposition to the flow of electrical current, usually measured in ohms (Ω). Resistance depends on the conductivity of the material, as well as size, shape, and temperature. Solenoid resistance can vary greatly with temperature; to compensate for this, current-controlled drivers are generally always used with proportional valves.
- **Threshold** is the minimum current required for valve response; see deadband.
- **Valve Driver** is a generic term for any device that sends a signal to a proportional valve. A valve driver may range from a simple electronic circuit attached to a knob or lever up to a microcontroller with custom software and multiple inputs and outputs.
- **Voltage** is the potential for current to flow in an electric circuit, usually measured in volts (V).

Proportional Valves

Application Notes

Typical Applications

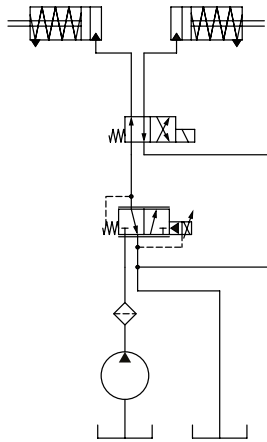

▲ Proportional Dual Clutch Circuit

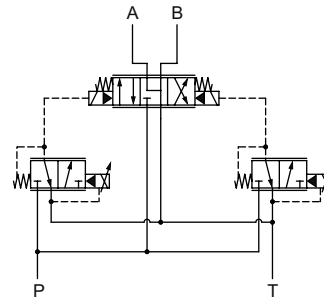

▲ Proportional Pilot Control

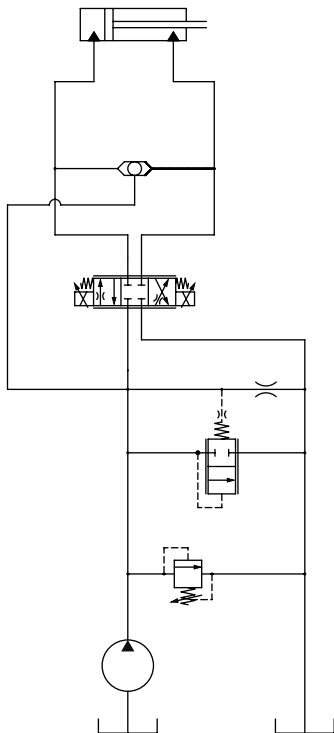

▲ Pressure compensated.
Cylinder control

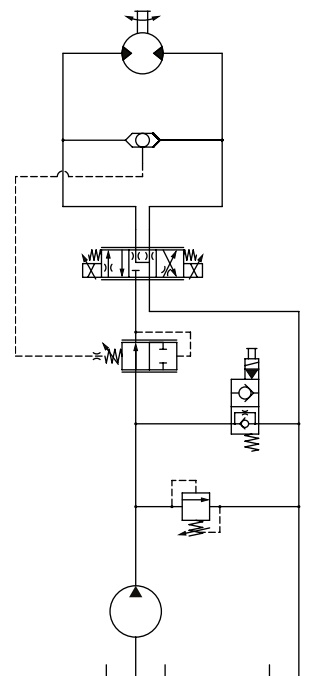

▲ Pressure compensated.
Motor control

Proportional Valves

Manual Override Options

Note: Manual overrides are intended for emergency use only, not for continuous duty operation.

"Omit/PN" - Push Pin

10, 12, and 16 series

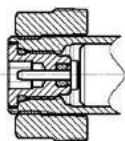

Product Availability

PSV10-NC	PSVP10-NOR	PFC10-RO	PFC10-PO
PSV12-NC	PSVP12-NOR	PFC12-RO	PFC12-PO
PSV16-NC	PSVP16-NOR	PFC16-RO	PFC16-PO
PSV10-NO	PFC10-RC	PFC10-PC	
PSV12-NO	PFC12-RC	PFC12-PC	
PSV16-NO	PFC16-RC	PFC16-PC	

OPERATION

1. Push the pin toward the valve using a hex key to actuate override
2. Remove the hex key to return to neutral position

"EN" - Screw Type

04 and 06 series

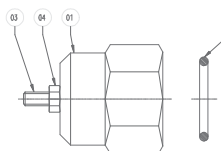

Product Availability

XMD 04	XMP 06	XRP 06
--------	--------	--------

OPERATION

1. Screw the screw clockwise to actuate override
2. Unscrew the screw counterclockwise to return to neutral position

"PAP" - Push and Pull

08 series

10 series

Product Availability

PSV10-34-02	PSV10-34-05
-------------	-------------

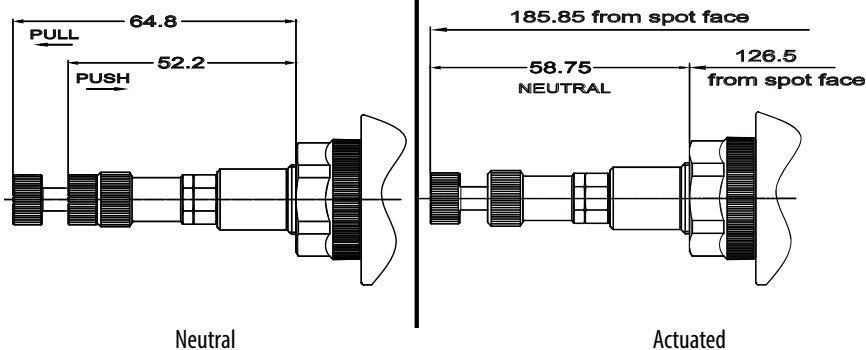

OPERATION

1. Push the knob toward the valve to actuate the override in one direction.
2. Pull the knob away from the valve to actuate the override in the opposite direction.
3. In either direction, release the knob to return the override to the neutral position.

Proportional Valves

Manual Override Options

Note: Manual overrides are intended for emergency use only, not for continuous duty operation.

"SPS" - Screw Type

10, 12, 16 series

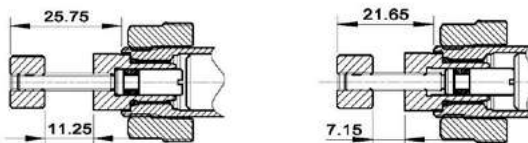

Neutral

Actuated

Product Availability

PSV10-NC	PSVP10-NOR	PFC10-RO	PFC10-PO
PSV12-NC	PSVP12-NOR	PFC12-RO	PFC12-PO
PSV16-NC	PSVP16-NOR	PFC16-RO	PFC16-PO
PSV10-NO	PFC10-RC	PFC10-PC	
PSV12-NO	PFC12-RC	PFC12-PC	
PSV16-NO	PFC16-RC	PFC16-PC	

OPERATION

1. Screw the knob clockwise to actuate override
2. Unscrew the knob counterclockwise to return to neutral position

"S" - Screw Type

10, 12, and 16 series

S - Screw type

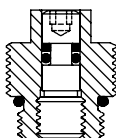

Neutral 3 mm hex

Product Availability

EPV10	EPV16	EFV2-12-C
EFV2-12-0	PPAR1-10	

"M" - Pin Type

10 and 16 series

M - Pin type

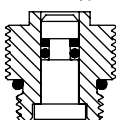

Neutral

Product Availability

EPV10	EPV16
-------	-------

*Only available for system pressures less than 210 bar [3000 psi]

"M" - Push and Pull

Product Availability

ESVL9-10-E	ESVL9-10-F
ESVL9-10-E-C	ESVL9-10-F-C

"6" - Screw Type

Product Availability

PFR21H	PFR24A
PPD22A	

"M" - Knob Type

Product Availability

ESV1-8-C	ESV1-10-C	ESV1-12-C
ESV1-8-0	ESV1-10-0	ESV1-12-0

Proportional Valves

Quick Reference

Proportional Directional Valves	Model No.	Cavity	Description	Flow*	Pressure	Page
	PSV10-34-02	SDC10-4	Proportional Directional Valve, 4-way, 3-position, Spool Type, Non-Compensated	22 l/min [5.8 US gpm]	250 bar [3600 psi]	15
	PSV12-34-02	CP12-4	Proportional Directional Valve, 4-way, 3-position, Spool Type, Non-Compensated	50 l/min [13 US gpm]	250 bar [3600 psi]	16
Proportional Directional Valves	Model No.	Cavity	Description	Flow*	Pressure	Page
	PSV08-34-05	SDC08-4	Proportional Directional Valve, 4-way, 3-position, Spool Type, Non-Compensated	12 l/min [3.2 US gpm]	240 bar [3500 psi]	17
	PSV10-34-05	SDC10-4	Proportional Directional Valve, 4-way, 3-position, Spool Type, Non-Compensated	22 l/min [5.8 US gpm]	250 bar [3600 psi]	18
	PSV12-34-05	CP12-4	Proportional Directional Valve, 4-way, 3-position, Spool Type, Non-Compensated	60 l/min [16 US gpm]	250 bar [3600 psi]	19
Proportional Directional Valves	Model No.	Cavity	Description	Flow*	Pressure	Page
	ESVL9-10-E	SDC10-5	Proportional Directional Valve, 5-way, 3-position, Spool Type, Non-Compensated	23 l/min [6 US gpm]	250 bar [3600 psi]	20
Proportional Directional Valves	Model No.	Cavity	Description	Flow*	Pressure	Page
	ESVL9-10-F	SDC10-5	Proportional Directional Valve, 5-way, 3-position, Spool Type, Non-Compensated	23 l/min [6 US gpm]	250 bar [3600 psi]	21
Proportional Directional Valves	Model No.	Cavity	Description	Flow*	Pressure	Page
	ESVL9-10-E-C	SDC10-5	Proportional Directional Valve, 5-way, 3-position, Spool Type, Non-Compensated, Load Sense Check	23 l/min [6 US gpm]	250 bar [3600 psi]	22
Proportional Directional Valves	Model No.	Cavity	Description	Flow*	Pressure	Page
	ESVL9-10-F-C	SDC10-5	Proportional Directional Valve, 5-way, 3-position, Spool Type, Non-Compensated, Load Sense Check	23 l/min [6 US gpm]	250 bar [3600 psi]	23

*Flow ratings are for reference only. Refer to individual product page for performance information.

Proportional Valves

Quick Reference

Proportional Flow Control Valves	Model No.	Cavity	Description	Flow*	Pressure	Page
	ESV1-8-C	SDC08-2	Proportional Flow Control Valve, Poppet Type, Normally Closed, Pilot Operated, Non-Compensated	32 l/min [8.4 US gpm]	210 bar [3000 psi]	24
	ESV1-10-C	SDC10-2	Proportional Flow Control Valve, Poppet Type, Normally Closed, Pilot Operated, Non-Compensated	70 l/min [18.5 US gpm]	210 bar [3000 psi]	25
	PSVP10-NCR	SDC10-2	Proportional Flow Control Valve, Poppet Type, Normally Closed, Pilot Operated, Non-Compensated	100 l/min [26 US gpm]	260 bar [3800 psi]	26
	ESV1-12-C	C-12-2	Proportional Flow Control Valve, Poppet Type, Normally Closed, Pilot Operated, Non-Compensated	103 l/min [27.3 US gpm]	210 bar [3000 psi]	27
	PSVP12-NCR	SDC12-2	Proportional Flow Control Valve, Poppet Type, Normally Closed, Pilot Operated, Non-Compensated	120 l/min [32 US gpm]	260 bar [3800 psi]	28
	PSVP16-NCR	SDC16-2	Proportional Flow Control Valve, Poppet Type, Normally Closed, Pilot Operated, Non-Compensated	176 l/min [46 US gpm]	260 bar [3800 psi]	29

Proportional Flow Control Valves	Model No.	Cavity	Description	Flow*	Pressure	Page
	ESV1-8-O	SDC08-2	Proportional Flow Control Valve, Poppet Type, Normally Open, Pilot Operated, Non-Compensated	32 l/min 8.4 US gpm]	210 bar [3000 psi]	30
	ESV1-10-O	SDC10-2	Proportional Flow Control Valve, Poppet Type, Normally Open, Pilot Operated, Non-Compensated	70 l/min [18.5 US gpm]	210 bar [3000 psi]	31
	PSVP10-NOR	SDC10-2	Proportional Flow Control Valve, Poppet Type, Normally Open, Pilot Operated, Non-Compensated	100 l/min [26 US gpm]	260 bar [3800 psi]	32
	ESV1-12-O	C-12-2	Proportional Flow Control Valve, Poppet Type, Normally Open, Pilot Operated, Non-Compensated	103 l/min [27.3 US gpm]	210 bar [3000 psi]	33
	PSVP12-NOR	SDC12-2	Proportional Flow Control Valve, Poppet Type, Normally Open, Pilot Operated, Non-Compensated	120 l/min [32 US gpm]	260 bar [3800 psi]	34
	PSVP16-NOR	SDC16-2	Proportional Flow Control Valve, Poppet Type, Normally Open, Pilot Operated, Non-Compensated	165 l/min [44 US gpm]	260 bar [3800 psi]	35

Proportional Flow Control Valves	Model No.	Cavity	Description	Flow*	Pressure	Page
	EPV10	SDC10-2	Proportional Flow Control Valve, Poppet Type, Normally Closed, Uni-Directional, Pressure Compensated	30 l/min [8 US gpm]	350 bar [5000 psi]	36

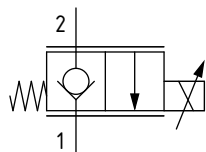

*Flow ratings are for reference only. Refer to individual product page for performance information.

Proportional Valves

Quick Reference

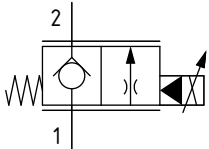
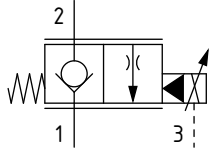
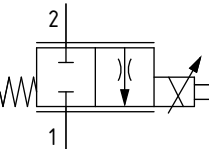
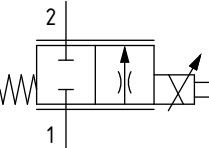
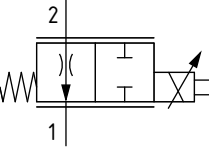
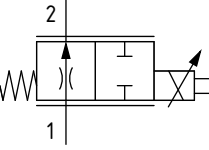
Proportional Flow Control Valves	Model No.	Cavity	Description	Flow*	Pressure	Page
	EPV16-A	C-16-3SU	Proportional Flow Control Valve, Poppet Type, Normally Closed, Pilot Operated, Pressure Compensated	160 l/min [42 US gpm]	280 bar [4000 psi]	38
	EPV16-B	C-16-3SU	Proportional Flow Control Valve, Poppet Type, Normally Closed, Pilot Operated, Pressure Compensated	160 l/min [42 US gpm]	280 bar [4000 psi]	40
	CP518-PNC	SDC08-2	Proportional Flow Control Valve, Spool Type, Normally Closed, Direct Acting, Non-Compensated	12 l/min [3.2 US gpm]	210 bar [3000 psi]	42
	PSV10-NC	SDC10-2	Proportional Flow Control Valve, Spool Type, Normally Closed, Direct Acting, Non-Compensated	40 l/min [10.6 US gpm]	260 bar [3800 psi]	43
	PSV12-NC	SDC12-2	Proportional Flow Control Valve, Spool Type, Normally Closed, Direct Acting, Non-Compensated	80 l/min [21 US gpm]	260 bar [3800 psi]	44
	PSV16-NC	SDC16-2	Proportional Flow Control Valve, Spool Type, Normally Closed, Direct Acting, Non-Compensated	100 l/min [26 US gpm]	260 bar [3800 psi]	45
	CP518-PNO	SDC08-2	Proportional Flow Control Valve, Spool Type, Normally Open, Direct Acting, Non-Compensated	11.5 l/min [3 US gpm]	210 bar [3000 psi]	46
	PSV10-NO	SDC10-2	Proportional Flow Control Valve, Spool Type, Normally Open, Direct Acting, Non-Compensated	45 l/min [12 US gpm]	260 bar [3800 psi]	47
	PSV12-NO	SDC12-2	Proportional Flow Control Valve, Spool Type, Normally Open, Direct Acting, Non-Compensated	100 l/min [26 US gpm]	260 bar [3800 psi]	48
	PSV16-NO	SDC16-2	Proportional Flow Control Valve, Spool Type, Normally Open, Direct Acting, Non-Compensated	110 l/min [29 US gpm]	260 bar [3800 psi]	49

*Flow ratings are for reference only. Refer to individual product page for performance information.

Proportional Valves

Quick Reference

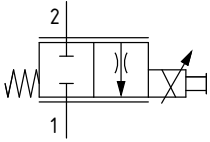
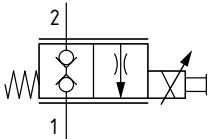
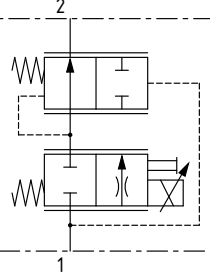
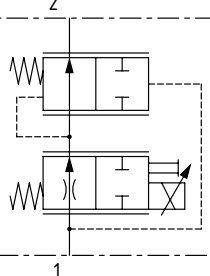
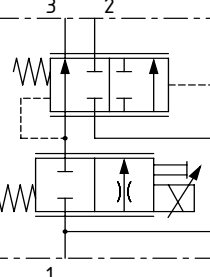
Proportional Flow Control Valves	Model No.	Cavity	Description	Flow*	Pressure	Page
	PFR24A	A6701	Proportional Flow Control Valve, Spool Type, Normally Closed, Direct Acting, Pressure Compensated	28 l/min [7.4 US gpm]	210 bar [3000 psi]	50
	PFR21H	A6701	Proportional Flow Control Valve, Poppet Type, Normally Closed, Direct Acting, Partially Compensated	20 l/min [5.3 US gpm]	210 bar [3000 psi]	51
	PFC10-RC	SDC10-2	Proportional Flow Control Valve, Normally Closed, Restrictive Type, Pressure Compensated	30 l/min [8 US gpm]	260 bar [3800 psi]	52
	PFC12-RC	SDC12-2	Proportional Flow Control Valve, Normally Closed, Restrictive Type, Pressure Compensated	65 l/min [17 US gpm]	260 bar [3800 psi]	53
	PFC16-RC	SDC16-2	Proportional Flow Control Valve, Normally Closed, Restrictive Type, Pressure Compensated	90 l/min [24 US gpm]	260 bar [3800 psi]	54
	PFC10-RO	SDC10-2	Proportional Flow Control Valve, Normally Open, Restrictive Type, Pressure Compensated	30 l/min [8 US gpm]	260 bar [3800 psi]	55
	PFC12-RO	SDC12-2	Proportional Flow Control Valve, Normally Open, Restrictive Type, Pressure Compensated	60 l/min [16 US gpm]	260 bar [3800 psi]	56
	PFC16-RO	SDC16-2	Proportional Flow Control Valve, Normally Open, Restrictive Type, Pressure Compensated	85 l/min [22.5 US gpm]	260 bar [3800 psi]	57
	PFC10-PC	SDC10-3	Proportional Flow Control Valve, Normally Closed, Priority Type, Pressure Compensated	40 l/min [10.6 US gpm]	260 bar [3800 psi]	58
	PFC12-PC	SDC12-3	Proportional Flow Control Valve, Normally Closed, Priority Type, Pressure Compensated	65 l/min [17 US gpm]	260 bar [3800 psi]	59
	EFV2-12-C	C-12-3	Proportional Flow Control Valve, Normally Closed, Priority Type, Pressure Compensated	57 l/min [15 US gpm]	210 bar [3000 psi]	60
	PFC16-PC	SDC16-3	Proportional Flow Control Valve, Normally Closed, Priority Type, Pressure Compensated	85 l/min [22.5 US gpm]	260 bar [3800 psi]	62

*Flow ratings are for reference only. Refer to individual product page for performance information.

Proportional Valves

Quick Reference

Proportional Flow Control Valves	Model No.	Cavity	Description	Flow*	Pressure	Page
	PFC10-PO	SDC10-3	Proportional Flow Control Valve, Normally Open, Priority Type, Pressure Compensated	35 l/min [9.2 US gpm]	260 bar [3800 psi]	63
	PFC12-PO	SDC12-3	Proportional Flow Control Valve, Normally Open, Priority Type, Pressure Compensated	70 l/min [18.5 US gpm]	260 bar [3800 psi]	64
	EFV2-12-O	C-12-3	Proportional Flow Control Valve, Normally Open, Priority Type, Pressure Compensated	53 l/min [14 US gpm]	210 bar [3000 psi]	65
	PFC16-PO	SDC16-3	Proportional Flow Control Valve, Normally Open, Priority Type, Pressure Compensated	90 l/min [24 US gpm]	260 bar [3800 psi]	67

Proportional Relief Valves	Model No.	Cavity	Description	Flow*	Pressure	Page
	XMD 04	NCS 04/2	Proportional Relief Valve, Poppet Type, Direct Acting, Normally Open	5 l/min [1.3 US gpm]	250 bar [3600 psi]	68

Proportional Relief Valves	Model No.	Cavity	Description	Flow*	Pressure	Page
	XMP 06	NCS 06/2	Proportional Relief Valve, Spool Type, Pilot Operated, Normally Open	50 l/min [13 US gpm]	250 bar [3600 psi]	69
	PAR1-10	SDC10-2	Proportional Relief Valve, Spool Type, Pilot Operated, Normally Open	57 l/min [15 US gpm]	240 bar [3500 psi]	70
	PAR1-16	SDC16-2	Proportional Relief Valve, Spool Type, Pilot Operated, Normally Open	132 l/min [35 US gpm]	210 bar [3000 psi]	71

Proportional Relief Valves	Model No.	Cavity	Description	Flow*	Pressure	Page
	PRV08-DAC	SDC08-2	Proportional Relief Valve, Poppet Type, Direct Acting, Normally Closed	3.8 l/min [1 US gpm]	215 bar [3100 psi]	72
	HPRV08-DAC	SDC08-2	Proportional Relief Valve, Poppet Type, Direct Acting, Normally Closed	1.9 l/min [0.5 US gpm]	350 bar [5000 psi]	73

Proportional Relief Valves	Model No.	Cavity	Description	Flow*	Pressure	Page
	PRV10-POC	SDC10-2	Proportional Relief Valve, Spool Type, Pilot Operated, Normally Closed	76 l/min [20 US gpm]	250 bar [3600 psi]	74
	PRV12-POC	SDC12-2	Proportional Relief Valve, Spool Type, Pilot Operated, Normally Closed	180 l/min [47 US gpm]	250 bar [3600 psi]	75

*Flow ratings are for reference only. Refer to individual product page for performance information.

Proportional Valves

Quick Reference

Proportional Pressure Reducing Valves	Model No.	Cavity	Description	Flow*	Pressure	Page
	EPRV2-8	SDC08-3	Proportional Pressure Reducing, Relieving, Direct Acting, Normally Open to Drain	7.6 l/min [2 US gpm]	35 bar [500 psi]	76
Proportional Pressure Reducing Valves	Model No.	Cavity	Description	Flow*	Pressure	Page
	PPD22A	A3531	Proportional Pressure Reducing, Relieving, Direct Acting, Normally Open to Drain	20 l/min [5.3 US gpm]	210 bar [3000 psi]	77
Proportional Pressure Reducing Valves	Model No.	Cavity	Description	Flow*	Pressure	Page
	PPR09-POD	SDC10-4	Proportional Pressure Reducing, Relieving, Pilot Operated, Normally Open to Drain	25 l/min [6.6 US gpm]	50 bar [725 psi]	78
	PPR09-POR	SDC10	Proportional Pressure Reducing, Relieving, Pilot Operated	25 l/min [6.6 US gpm]	50 bar [725 psi]	79
Proportional Pressure Reducing Valves	Model No.	Cavity	Description	Flow*	Pressure	Page
	XRP 06	NCS 06/3	Proportional Pressure Reducing, Relieving, Pilot Operated	25 l/min [6.6 US gpm]	315 bar [4600 psi]	80
	PPAR1-10	SDC10-3	Proportional Pressure Reducing, Relieving, Pilot Operated	30 l/min [8 US gpm]	210 bar [3000 psi]	81
Proportional Pressure Reducing Valves	Model No.	Cavity	Description	Flow*	Pressure	Page
	PPR10-PAC	SDC10-3	Proportional Pressure Reducing, Relieving, Pilot Operated	38 l/min [10 US gpm]	250 bar [3600 psi]	82

*Flow ratings are for reference only. Refer to individual product page for performance information.

Proportional Valves

PSV10-34-02

Proportional Directional Valve, 4-way, 3-position, Spool Type, Non-Compensated

250 bar [3600 psi] • 22 l/min [5.8 US gpm]

DESCRIPTION AND OPERATION

This is a 4-way, 3-position, spool type, non-compensated proportional directional valve. In its de-energized condition, all ports are blocked. Increasing the current to the bottom coil will cause the spool to move, proportionally opening flow from port 3 to 2 with return flow passing from port 4 to 1. Increasing the current to the top coil will proportionally open flow from port 3 to 4 with return flow passing from port 2 to 1. Using this as a variable orifice in conjunction with a compensator, the valve will provide a compensated flow to an actuator in both directions. Port 1 should be used as the tank port with a maximum back pressure of 150 bar. For applications with unequal flows, the highest flow should be connected to Port 2. For optimal performance, install with the solenoid valve below the tank oil level in the horizontal or inverted position, reducing the chance for trapped air in the valve.

SCHEMATIC

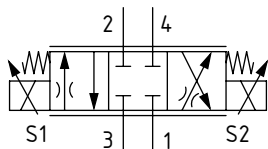

DIMENSIONS

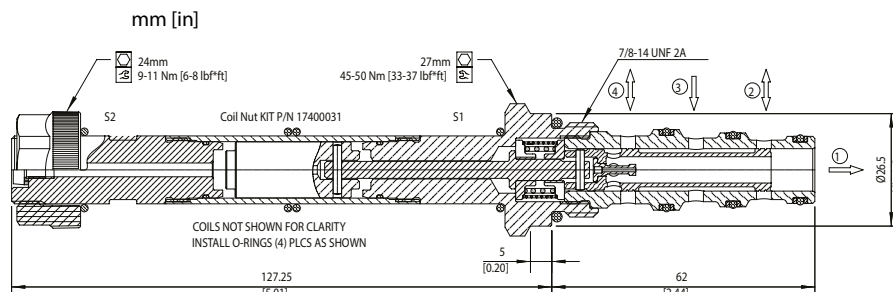

PERFORMANCE DATA

Rated pressure*	250 bar [3600 psi]
Rated flow @ 10 bar [145 psi]	22 l/min [5.8 US gpm]
Maximum Hysteresis	4%
Threshold current	0.5 A [12 VDC coil] 0.25 A [24 VDC coil]
Maximum control current	1.5 A [12 VDC coil] 0.8 A [24 VDC coil]
Coil Options	M16, R16
Weight	0.77 kg [1.7 lbs]
Cavity	SDC10-4

*Rated Pressure based on NFPA fatigue test standards (at 1 Million Cycles)

PERFORMANCE CURVES

Pressure drop

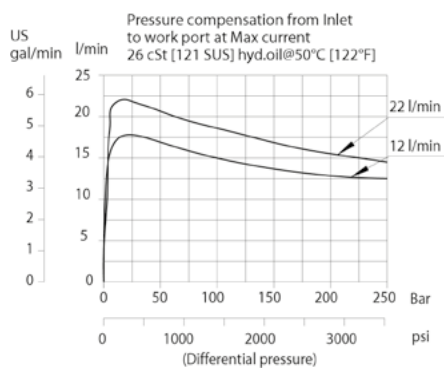

Operating curves with M16 coil and plastic nut

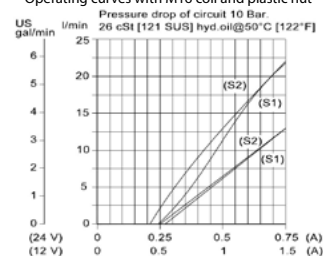

Operating curves with R16 coil and steel nut

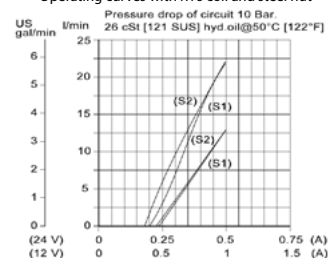

MODEL CODE

PSV10 - 34 - 02 - 12D - DE - 22 - PAP - B - 00

Coil Voltage

Standard Coil Code	Robust Coil Code	Coil Voltage
00	R00	No Coil, nut included*
12D	R12D	12 VDC
24D	R24D	24 VDC

*Standard Coil - Plastic coil nut and o-rings (p/n 17400031)

*Robust Coil - Steel coil nut and no o-rings (p/n 173804910)

Rated Flow @ 10 bar [145 psi]

Code	Flow
12	12 l/min (3.2 US gpm)
22	22 l/min (5.8 US gpm)

Connector Type

Standard Coil Code	Robust Coil Code	Connector Type
00	R00	No Coil
AJ		Amp Junior
AS	AS	AMP SuperSeal 1.5
DE	DE	Deutsch
FL	FL	Flying Leads
DN		DIN 43650

Manual Override Option

Omit	No override
PAP	Push and Pull

Housing

Code	Ports & Material	Housing Model Code
00	No Housing	
L3B	AL 3/8 BSP	SDC10-4-L3B
L4B	AL, 1/2 BSP	SDC10-4-L4B
6S	AL #6 SAE	CP10-4-6S
8S	AL, #8 SAE	CP10-4-8S

* Aluminum bodies are to be used for pressures less than 210 bar [3000 psi].

* Additional housings available

Seal Option

Code	Seal kit
B	Buna - N 354001919
V	Viton 354002019

Proportional Valves

PSV12-34-02

Proportional Directional Valve, 4-way, 3-position, Spool Type, Non-Compensated

250 bar [3600 psi] • 50 l/min [13 US gpm]

DESCRIPTION AND OPERATION

This is a 4-way, 3-position, spool type, non-compensated proportional directional valve. In its de-energized condition, all ports are blocked. Increasing the current to the bottom coil will cause the spool to move, proportionally opening flow from port 3 to 2 with return flow passing from port 4 to 1. Increasing the current to the top coil will proportionally open flow from port 3 to 4 with return flow passing from port 2 to 1. Using this as a variable orifice in conjunction with a compensator, the valve will provide a compensated flow to an actuator in both directions. Port 1 should be used as the tank port with a maximum back pressure of 150 bar. For applications with unequal flows, the highest flow should be connected to Port 2. For optimal performance, install with the solenoid valve below the tank oil level in the horizontal or inverted position, reducing the chance for trapped air in the valve.

SCHEMATIC

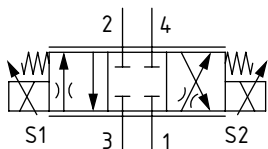

DIMENSIONS

mm [in]

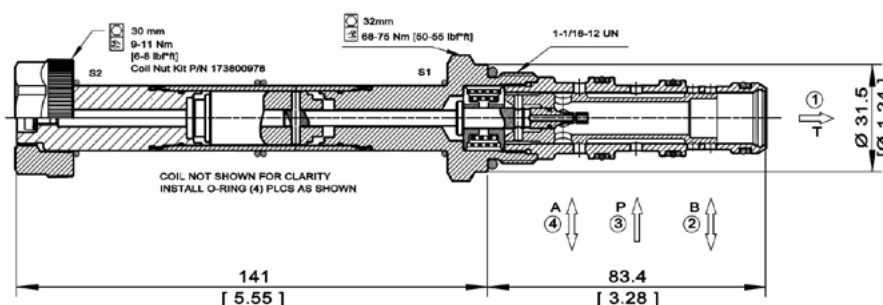

PERFORMANCE DATA

Rated pressure*	250 bar [3600 psi]
Rated flow @ 10 bar [145 psi]	50 l/min [13 US gpm]
Maximum Hysteresis	4%
Threshold current	0.50 A [12 VDC coil] 0.25 A [24 VDC coil]
Maximum control current	1.8 A [12 VDC coil] 0.9 A [24 VDC coil]
Coil Options	M19
Weight	1.2 kg [2.64 lb]
Cavity	CP12-4

*Rated Pressure based on NFPA fatigue test standards (at 1 Million Cycles)

PERFORMANCE CURVES

Pressure compensation from Inlet to work port at Max current.
26 cSt [121 SUS] hyd.oil@50°C [122°F]

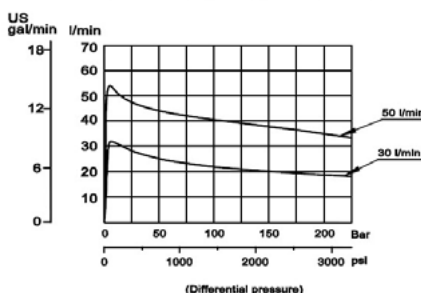

Operating curves with M19 coil and nut.

Curves made with a logic element set at 10 Bar.
26 cSt [121 SUS] hyd.oil@50C [122F]

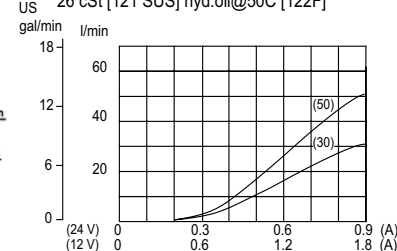

MODEL CODE

PSV12 - 34 - 02 - 50 - 12D - DE - B - 00

Rated Flow @ 10 bar [145 psi]

Code	Flow
30	30 l/min (8 US gpm)
50	50 l/min (13 US gpm)

Coil Voltage

00 - No coil, nut included*
12D - 12 VDC
24D - 24 VDC

*Standard Coil - Plastic coil nut and o-rings (p/n 173800978)

Connector Type

00 - No coil
AJ - AMP Junior
AS - AMP SuperSeal 1.5
DE - Deutsch
DN - DIN 46650
FL - Flying Leads

Housing

Code	Ports & Material	Housing Model Code
00	No Housing	
3B	AL 3/8 BSP	CP12-4-3B
4B	AL, 1/2 BSP	CP12-4-4B
8S	AL #8 SAE	CP12-4-8S
10S	AL, #10 SAE	CP12-4-10S

* Aluminum bodies are to be used for pressures less than 210 bar [3000 psi].
* Additional housings available

Seal Option

Code	Seal kit
B - Buna - N	11106420
V - Viton	11106444

Proportional Valves

PSV08-34-05

Proportional Directional Valve, 4-way, 3-position, Spool Type, Non-Compensated

240 bar [3500 psi] • 12 l/min [3.2 US gpm]

DESCRIPTION AND OPERATION

This is a 4-way, 3-position, spool type, non-compensated proportional directional valve. In its de-energized condition, port 3 is blocked, while ports 2 and 4 are open to port 1. Increasing the current to the bottom coil will cause the spool to move, proportionally opening flow from port 3 to 2 with return flow passing from port 4 to 1. Increasing the current to the top coil will proportionally open flow from port 3 to 4 with return flow passing from port 2 to 1. Using this as a variable orifice in conjunction with a compensator, the valve will provide compensated flow to an actuator in both directions. Port 1 should be used as the tank port with a maximum back pressure of 150 bar. For applications with unequal flows, the highest flow should be connected to Port 2. For optimal performance, install with the solenoid valve below the tank oil level in the horizontal or inverted position, reducing the chance for trapped air in the valve.

SCHEMATIC

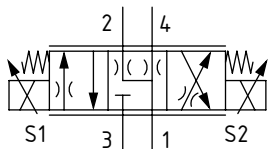

DIMENSIONS

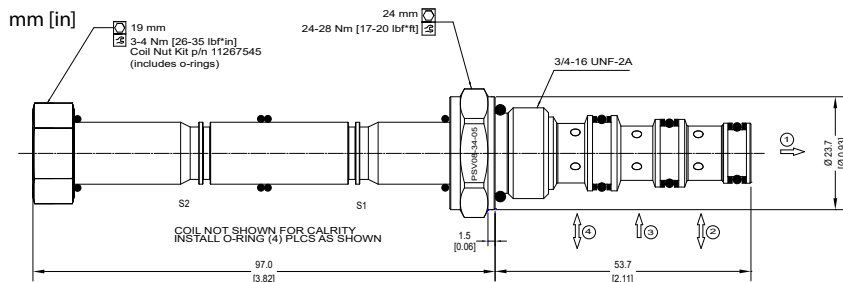

PERFORMANCE DATA

Rated pressure*	240 bar [3500 psi]
Rated flow @ 10 bar [145 psi]	12 l/min [3.2 US gpm]
Leakage	160 ml/min [10 in ³] at 210 bar [3000 psi]
Maximum Hysteresis	5%
Threshold current	0.5 A [12 VDC coil] 0.25 A [24 VDC coil]
Maximum control current	1.0 A [12 VDC coil] 0.5 A [24 VDC coil]
Coil Options	M13, R13
Weight	0.55 kg [1.21 lb]
Cavity	SDC08-4

*Rated pressure based on NFPA fatigue test standards (at 1 million cycles)

PERFORMANCE CURVES

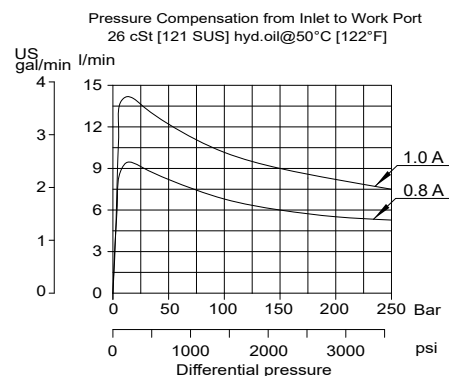
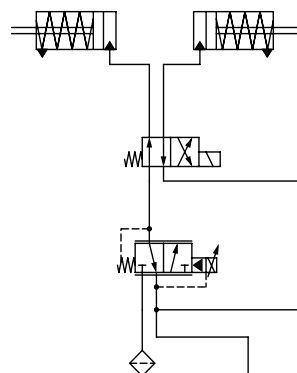

MODEL CODE

PSV08 - 34 - 05 - 12D - DE - 12 - B - 00

Coil Voltage

Standard Coil Code	Robust Coil Code	Coil Voltage
00	R00	No Coil, nut included*
12D	R12D	12 VDC
24D	R24D	24 VDC

*Steel coil nut and o-rings (p/n 11267545)

Connector Type

Standard Coil Code	Robust Coil Code	Connector Type
00	R00	No Coil
AJ		Amp Junior
AS	AS	AMP SuperSeal 1.5
DE	DE	Deutsch
FL	FL	Flying Leads
DN		DIN 43650

Rated Flow @ 10 bar [145 psi]

Code	Flow
4	4 l/min [1 US gp]
12	12 l/min [3.2 US gpm]

Housing

Code	Ports & Material	Housing Model Code
00	No Housing	
4S	#4 SAE, AL	CP08-4-4S
6S	#6 SAE, AL	CP08-4-6S
56S	#6 SAE, Steel	CP08-4-56S
L2B	1/4 BSP, AL	SDC08-4-L2B
S3B	3/8 BSP, Steel	CP08-4-S3B

* Aluminum bodies are to be used for pressures less than 210 bar [3000 psi].
* Additional housings available

Seal Option

Code	Seal Kit
B - Buna	354003319
V - Viton	354003919

Proportional Valves

PSV10-34-05

Proportional Directional Valve, 4-way, 3-position, Spool Type, Non-Compensated

250 bar [3600 psi] • 22 l/min [5.8 US gpm]

DESCRIPTION AND OPERATION

This is a 4-way, 3-position, spool type, non-compensated proportional directional valve. In its de-energized condition, port 3 is blocked, while ports 2 and 4 are open to port 1. Increasing the current to the bottom coil will cause the spool to move, proportionally opening flow from port 3 to 2 with return flow passing from port 4 to 1. Increasing the current to the top coil will proportionally open flow from port 3 to 4 with return flow passing from port 2 to 1. Using this as a variable orifice in conjunction with a compensator, the valve will provide compensated flow to an actuator in both directions. Port 1 should be used as the tank port with a maximum back pressure of 150 bar. For applications with unequal flows, the highest flow should be connected to Port 2. For optimal performance, install with the solenoid valve below the tank oil level in the horizontal or inverted position, reducing the chance for trapped air in the valve.

SCHEMATIC

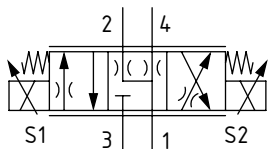

DIMENSIONS

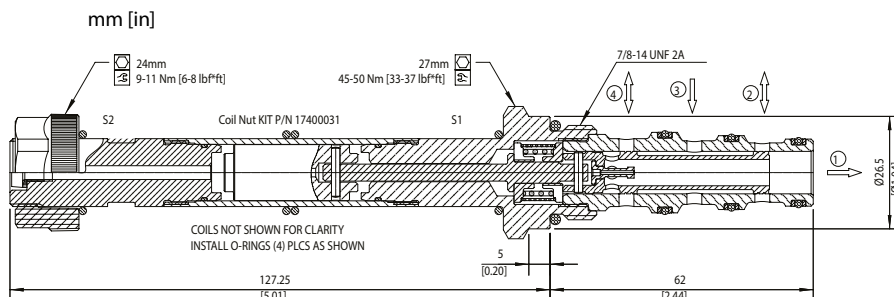

PERFORMANCE DATA

Rated pressure*	250 bar [3600 psi]
Rated flow @ 10 bar [145 psi]	22 l/min [5.8 US gpm]
Maximum Hysteresis	4%
Threshold current	0.5 A [12 VDC coil] 0.25 A [24 VDC coil]
Maximum control current	1.5 A [12 VDC coil] 0.8 A [24 VDC coil]
Coil Options	M16, R16
Weight	0.77 kg [1.7 lb]
Cavity	SDC10-4

*Rated pressure based on NFPA fatigue test standards (at 1 million cycles)

PERFORMANCE CURVES

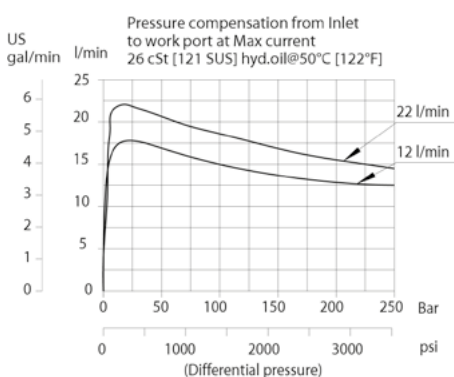

Operating curves with M16 coil and plastic nut

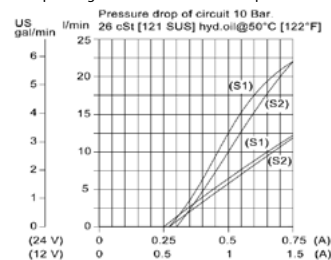

Operating curves with R16 coil and steel nut

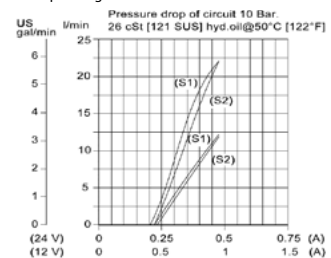

MODEL CODE

PSV10 - 34 - 05 - 12D - DE - 22 - PAP - B - 00

Coil Voltage

Standard Coil Code	Robust Coil Code	Coil Voltage
00	R00	No Coil, nut included*
12D	R12D	12 VDC
24D	R24D	24 VDC

*Standard Coil - Plastic coil nut and o-rings (p/n 17400031)

*Robust Coil - Steel coil nut and no o-rings (p/n 173804910)

Rated flow @ 10 bar [145 psi]

Code	Flow
3	3 l/min [0.8 US gpm]
12	12 l/min [3.2 US gpm]
22	22 l/min [5.8 US gpm]

Connector Type

Standard Coil Code	Robust Coil Code	Connector Type
00	R00	No Coil
AJ		Amp Junior
AS	AS	AMP SuperSeal 1.5
DE	DE	Deutsch
FL	FL	Flying Leads
DN		DIN 43650

Manual Override

Omit - No override
PAP - Push and Pull

Housing

Code	Ports & Material	Housing Model Code
00	No Housing	
L3B	AL 3/8 BSP	SDC10-4-L3B
L4B	AL, 1/2 BSP	SDC10-4-L4B
6S	AL #6 SAE	CP10-4-6S
8S	AL, #8 SAE	CP10-4-8S

* Aluminum bodies are to be used for pressures less than 210 bar [3000 psi]
* Additional housings available

Seal Option

Code	Seal kit
B - Buna - N	354001919
V - Viton	354002019

Proportional Valves

PSV12-34-05

Proportional Directional Valve, 4-way, 3-position, Spool Type, Non-Compensated

250 bar [3600 psi] • 60 l/min [16 US gpm]

DESCRIPTION AND OPERATION

This is a 4-way, 3-position, spool type, non-compensated proportional directional valve. In its de-energized condition, port 3 is blocked, while ports 2 and 4 are open to port 1. Increasing the current to the bottom coil will cause the spool to move, proportionally opening flow from port 3 to 2 with return flow passing from port 4 to 1. Increasing the current to the top coil will proportionally open flow from port 3 to 4 with return flow passing from port 2 to 1. Using this as a variable orifice in conjunction with a compensator, the valve will provide compensated flow to an actuator in both directions. Port 1 should be used as the tank port with a maximum back pressure of 150 bar. For applications with unequal flows, the highest flow should be connected to Port 2. For optimal performance, install with the solenoid valve below the tank oil level in the horizontal or inverted position, reducing the chance for trapped air in the valve.

SCHEMATIC

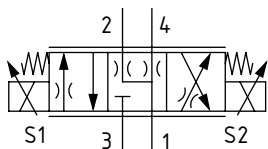

DIMENSIONS

mm [in]

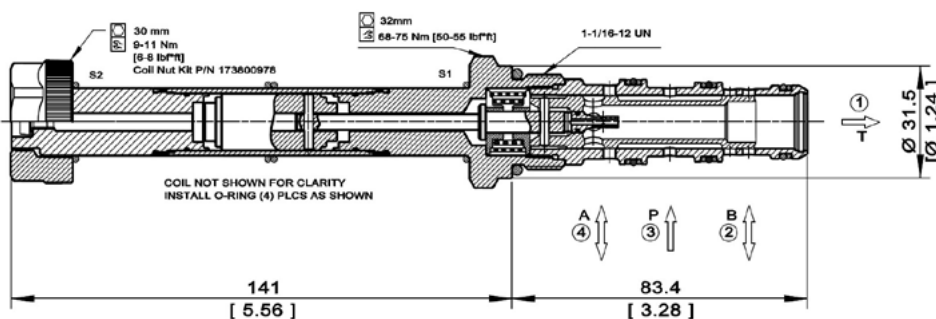

PERFORMANCE DATA

Rated pressure*	250 bar [3600 psi]
Rated flow @ 10 bar [145 psi]	60 l/min [16 US gpm]
Maximum Hysteresis	4%
Threshold current	0.5 A [12 VDC coil] 0.25 A [24 VDC coil]
Maximum control current	1.8 A [12 VDC coil] 0.9 A [24 VDC coil]
Coil Options	M19
Weight	1.2 kg [2.64 lb]
Cavity	CP12-4

*Rated Pressure based on NFPA fatigue test standards (at 1 Million Cycles)

PERFORMANCE CURVES

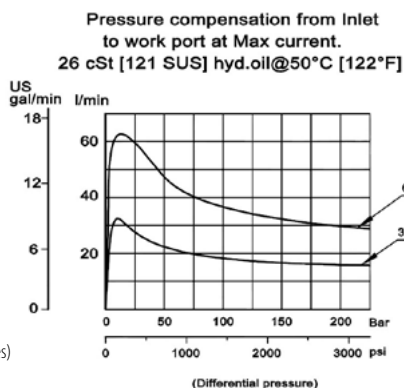

Operating curves with M19 coil and nut.

Curves made with a logic element set at 10 Bar.
26 cSt [121 SUS] hyd.oil@50°C [122°F]

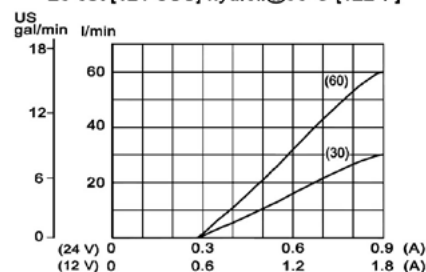

MODEL CODE

PSV12 - 34 - 05 - 60 - 12D - DE - B - 00

Rated Flow @ 10 bar [145 psi]

Code	Flow
30	30 l/min (8 US gpm)
60	60 l/min (16 US gpm)

Coil Voltage

00 - No coil, nut included*
12D - 12 VDC
24D - 24 VDC

*Standard Coil - Plastic coil nut and o-rings (p/n 173800978)

Connector Type

00 - No coil
AJ - AMP Junior
AS - AMP SuperSeal 1.5
DE - Deutsch
DN - DIN 46650
FL - Flying Leads

Housing

Code	Ports & Material	Housing Model Code
00	No Housing	
3B	AL 3/8 BSP	CP12-4-3B
4B	AL, 1/2 BSP	CP12-4-4B
8S	AL #8 SAE	CP12-4-8S
10S	AL, #10 SAE	CP12-4-10S

* Aluminum bodies are to be used for pressures less than 210 bar [3000 psi].
* Additional housings available

Seal Option

Code	Seal kit
B - Buna - N	11106420
V - Viton	11106444

Proportional Valves

ESVL9-10-E

Proportional Directional Valve, 5-way, 3-position, Spool Type, Non-Compensated

250 bar [3600 psi] • 23 l/min [6 US gpm]

DESCRIPTION AND OPERATION

This is a 5-way, 3-position, spool type, non-compensated proportional directional valve. In its de-energized condition, all ports are blocked. Increasing the current to the bottom coil will cause the spool to move, proportionally opening flow from port 5 to 4 with return flow from port 2 to 3. Increasing the current to the top coil will proportionally open flow from port 5 to 2 with return flow from port 4 to 3. In both cases, port 5 will also be opened to port 1, which acts as the load sense port. Using this as a variable orifice in conjunction with a compensator, the valve will provide compensated flow to an actuator in both directions. For optimal performance, install with the solenoid valve below the tank oil level in the horizontal or inverted position, reducing the chance for trapped air in the valve.

SCHEMATIC

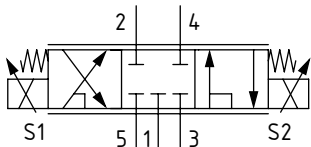

DIMENSIONS

mm [in]

Coil Nut Torque
5-8 Nm [4-6 ft lbs]

Installation torque
5-68 - 75 Nm [50 - 55 ft. lbs.]

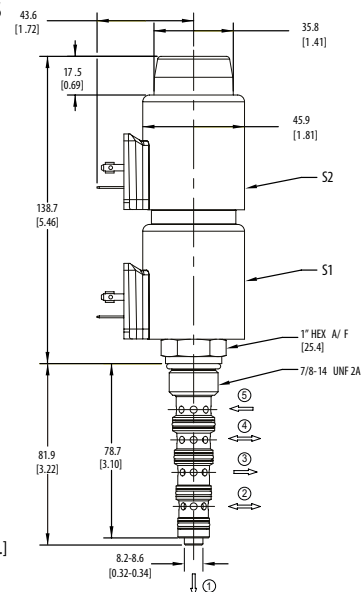

PERFORMANCE DATA

Rated pressure*	250 bar [3600 psi]
Rated flow @ 10 bar [145 psi]	23 l/min [6 US gpm]
Leakage	250 ml/min (10 in ³ /min) max. @ 210 bar [3000 psi]
Maximum Hysteresis	5%
Recommended PWM frequency	100 Hz
Maximum control current	1.6 A [12 VDC coil] 0.8 A [24 VDC coil]
Coil Options	L series
Weight with coils	1.2 kg [2.65 lb]
Cavity	SDC10-5

*Rated pressure based on NFPA fatigue test standards (at 1 million cycles)

PERFORMANCE CURVES

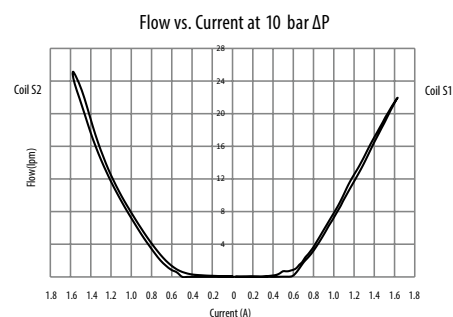
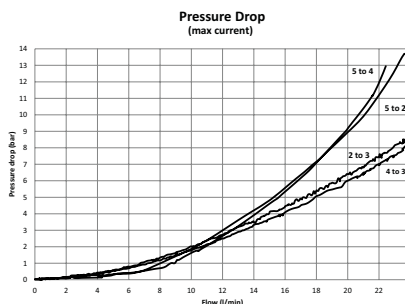

MODEL CODE

ESVL9 - 10 - V - E - M - S - 3G - 012D - N - L - 0 - A

Seal Option

Code **Seal kit**

Omit - Buna - N 9901261-000

V - Viton 9901262-000

Manual Override Option

O - No manual override

M - Push and Pull

Housing Material

Omit - No Housing

S - Steel

Housing

Code **Ports** **Steel**

0 No housing

3G 3/8" BSP 6042921-001

* Aluminum bodies are to be used for pressures less than 210 bar [3000 psi].

* Additional housings available

Coil series

Omit - No coil

L - L series, 28W

Connector Type

Omit - No coil

N - Deutsch

Coil Voltage

00 - No coil, nut and spacer included

012D - 12V DC

024D - 24V DC

Spare parts

Coil Nut for MO 6038813-001

Coil Nut w/o MO 02-148332

Coil Spacer 6038409-001

Proportional Valves

ESVL9-10-F

Proportional Directional Valve, 5-way, 3-position, Spool Type, Non-Compensated

250 bar [3600 psi] • 23 l/min [6 US gpm]

DESCRIPTION AND OPERATION

This is a 5-way, 3-position, spool type, non-compensated proportional directional valve. In its de-energized condition, ports 5 and 1 are blocked, while ports 2 and 4 are open to port 3. Increasing the current to the bottom coil will cause the spool to move, proportionally opening flow from port 5 to 4 with return flow from port 2 to 3. Increasing the current to the top coil will proportionally open flow from port 5 to 2 with return flow from port 4 to 3. In both cases, port 5 will also be opened to port 1, which acts as the load sense port. Using this as a variable orifice in conjunction with a compensator, the valve will provide compensated flow to an actuator in both directions. For optimal performance, install with the solenoid valve below the tank oil level in the horizontal or inverted position, reducing the chance for trapped air in the valve.

SCHEMATIC

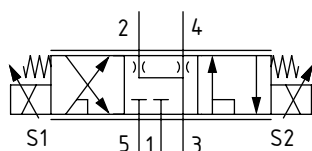

DIMENSIONS

mm [in]

Coil Nut Torque
5-8 Nm [4-6 ft lbs]

Installation torque
5-68 - 75 Nm [50 - 55 ft. lbs.]

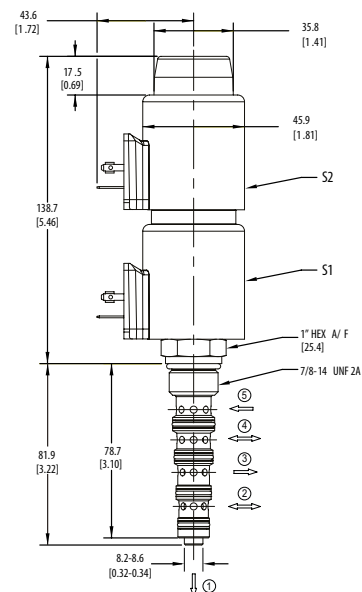

PERFORMANCE DATA

Rated pressure*	250 bar [3600 psi]
Rated flow@ 10 bar [145 psi]	23 l/min [6 US gpm]
Leakage	250 ml/min (10 in ³ /min) max. @ 210 bar [3000 psi]
Maximum Hysteresis	5%
Recommended PWM frequency	100 Hz
Maximum control current	1.6 A [12 VDC coil] 0.8 A [24 VDC coil]
Coil Options	L series
Weight	1.2 kg [2.65 lb]
Cavity	SDC10-5

*Rated pressure based on NFPA fatigue test standards (at 1 million cycles)

PERFORMANCE CURVES

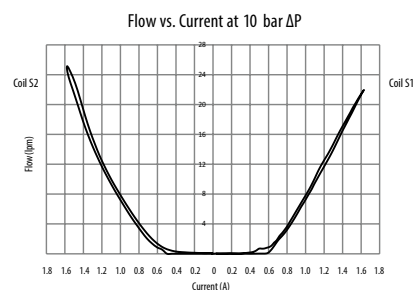
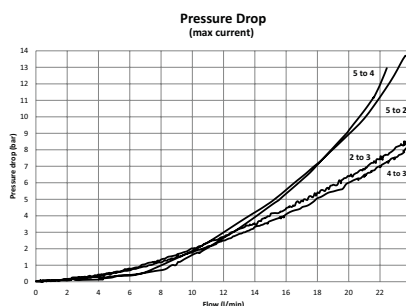

MODEL CODE

ESVL9 - 10 - V - F - M - S - 0 - 012D - N - L - 0 - A

Seal Option

Code	Seal kit
Omit - Buna - N	9901261-000
V - Viton	9901262-000

Manual Override Option

O - No manual override
M - Push and Pull

Housing Material

Omit - No Housing
S - Steel

Housing

Code	Ports	Steel
0	No housing	
3G	3/8" BSP	6042921-001

* Aluminum bodies are to be used for pressures less than 210 bar [3000 psi].

* Additional housings available

Coil series

Omit - No coil
L - L series, 28W

Connector Types

Omit - No coil
N - Deutsch

Coil Voltage

00 - No coil, nut and spacer included
012D - 12V DC
024D - 24V DC

Spare parts

Coil Nut for MO 6038813-001
Coil Nut w/o MO 02-148332
Coil Spacer 6038409-001

Proportional Valves

ESVL9-10-E-C

Proportional Directional Valve, 5-way, 3-position, Spool Type, Non-Compensated, Load Sense Check
250 bar [3600 psi] • 23 l/min [6 US gpm]

DESCRIPTION AND OPERATION

This is a 5-way, 3-position, spool type, non-compensated proportional directional valve. In its de-energized condition, all ports are blocked. Increasing the current to the bottom coil will cause the spool to move, proportionally opening flow from port 5 to 4 with return flow from port 2 to 3. Increasing the current to the top coil will proportionally open flow from port 5 to 2 with return flow from port 4 to 3. In both cases, port 5 will also be opened to port 1, which acts as the load sense port. An integral check valve in port 1 prevents reverse flow and allows separation of the load sense pressures of valves in parallel. Using this as a variable orifice in conjunction with a compensator, the valve will provide compensated flow to an actuator in both directions. For optimal performance, install with the solenoid valve below the tank oil level in the horizontal or inverted position, reducing the chance for trapped air in the valve.

SCHEMATIC

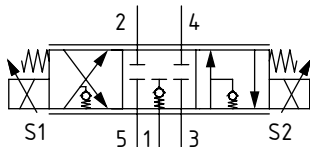

PERFORMANCE DATA

Rated pressure*	250 bar [3600 psi]
Rated flow@ 10 bar [145 psi]	23 l/min [6 US gpm]
Leakage	250 ml/min (10 in ³ /min) max. @ 210 bar [3000 psi]
Maximum Hysteresis	5%
Recommended PWM frequency	100 Hz
Maximum control current	1.6 A [12 VDC coil] 0.8 A [24 VDC coil]
Coil Options	L series
Weight	1.25 kg [2.76 lb]
Cavity	SDC10-5

*Rated pressure based on NFPA fatigue test standards (at 1 million cycles)

MODEL CODE

ESVL9 - 10 - V - E - M - S - O - 012D - N - L - C - A

Seal Option

Code	Seal kit
Omit - Buna - N	9901261-000
V - Viton	9901262-000

Manual Override Option

O - No manual override
M - Push and Pull

Housing Material

Omit - No Housing
S - Steel

Housing

Code	Ports	Steel
O	No housing	
3G	3/8" BSP	6042921-001

* Aluminum bodies are to be used for pressures less than 210 bar [3000 psi].

* Additional housings available

Load Sense Check Valve

Coil series

Omit - No coil
L - L series, 28V

Connector Types

Omit - No coil
N - Deutsch

Coil Voltage

O0 - No coil, nut and spacer included
012D - 12V DC
024D - 24V DC

Spare parts

Coil Nut for MO 6038813-001
Coil Nut w/o MO 02-148332
Coil Spacer 6038409-001

DIMENSIONS

mm [in]

Coil Nut Torque
5-8 Nm [4-6 ft lbs]

Installation torque
5-68 - 75 Nm [50 - 55 ft. lbs.]

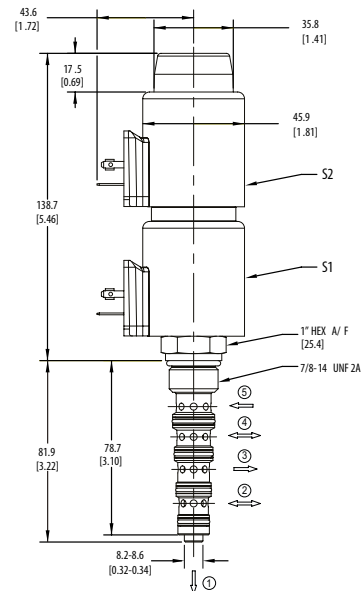

PERFORMANCE CURVES

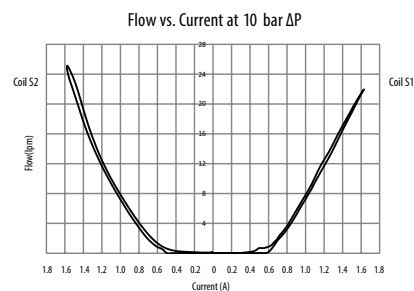
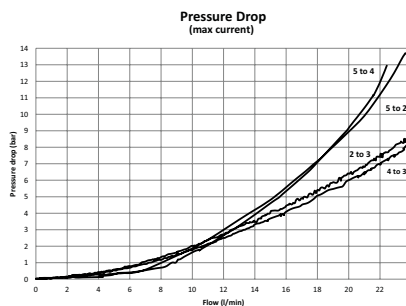

Proportional Valves

ESVL9-10-F-C

Proportional Directional Valve, 5-way, 3-position, Spool Type, Non-Compensated, Load Sense Check

250 bar [3600 psi] • 23 l/min [6 US gpm]

DESCRIPTION AND OPERATION

This is a 5-way, 3-position, spool type, non-compensated proportional directional valve. In its de-energized condition, ports 5 and 1 are blocked, while ports 2 and 4 are open to port 3. Increasing the current to the bottom coil will cause the spool to move, proportionally opening flow from port 5 to 4 with return flow from port 2 to 3. Increasing the current to the top coil will proportionally open flow from port 5 to 2 with return flow from port 4 to 3. In both cases, port 5 will also be opened to port 1, which acts as the load sense port. An integral check valve in port 1 prevents reverse flow and allows separation of the load sense pressures of valves in parallel. Using this as a variable orifice in conjunction with a compensator, the valve will provide compensated flow to an actuator in both directions. For optimal performance, install with the solenoid valve below the tank oil level in the horizontal or inverted position, reducing the chance for trapped air in the valve.

SCHEMATIC

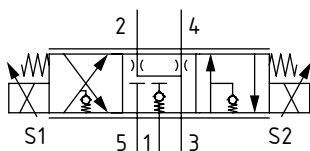

PERFORMANCE DATA

Rated pressure*	250 bar [3600 psi]
Rated flow@ 10 bar [145 psi]	23 l/min [6 US gpm]
Leakage	250 ml/min (10 in ³ /min) max. @ 210 bar [3000 psi]
Maximum Hysteresis	5%
Recommended PWM frequency	100 Hz
Maximum control current	1.6 A [12 VDC coil] 0.8 A [24 VDC coil]
Coil Options	L series
Weight	1.25 kg [2.76 lb]
Cavity	SDC10-5

*Rated pressure based on NFPA fatigue test standards (at 1 million cycles)

MODEL CODE

ESVL9 - 10 - V - F - M - S - 3G - 012D - N - L - C - A

Seal Option

Code	Seal kit
Omit - Buna - N	9901261-000
V - Viton	9901262-000

Manual Override Option

O - No manual override
M - Push and Pull

Housing Material

Omit - No Housing
S - Steel

Housing

Code	Ports	Steel
O	No housing	
3G	3/8" BSP	6042921-001

* Aluminum bodies are to be used for pressures less than 210 bar [3000 psi].

* Additional housings available

Load Sense Check Valve

Coil series

Omit - No coil
L - L series, 28W

Connector Types

Omit - No coil
N - Deutsch

Coil Voltage

O0 - No coil, nut and spacer included
012D - 12V DC without diode
024D - 24V DC without diode

Spare parts

Coil Nut for MO 6038813-001
Coil Nut w/o MO 02-148332
Coil Spacer 6038409-001

DIMENSIONS

mm [in]

Coil Nut Torque
5-8 Nm [4-6 ft lbs]

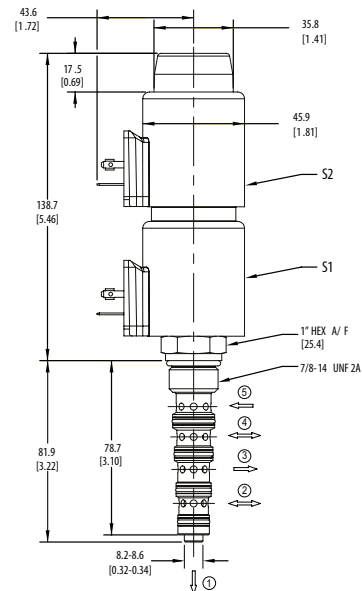

Installation torque
5-68 - 75 Nm [50 - 55 ft. lbs.]

PERFORMANCE CURVES

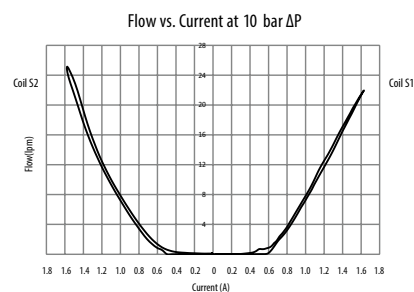
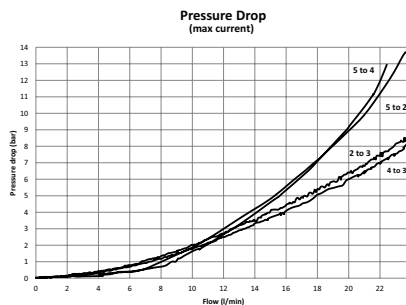

Proportional Valves

ESV1-8-C

Proportional Flow Control Valve, Poppet Type, Normally Closed, Pilot Operated, Non-Compensated

210 bar [3000 psi] • 32 l/min [8.4 US gpm]

DESCRIPTION AND OPERATION

This is a 2-way, poppet type, normally closed, pilot operated non-compensated proportional valve. In the de-energized condition, flow is blocked from port 2 to 1 but free flow from port 1 to 2. Energizing the coil will proportionally lift the poppet off its seat opening port 2 to 1, while flow from port 1 to 2 will remain restricted. Used in conjunction with a compensator, the valve will act as the control orifice for a pressure compensated flow control. This valve is available with an optional manual override.

SCHEMATIC

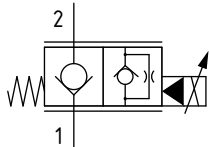

PERFORMANCE DATA

Rated pressure*	210 bar [3000 psi]
Rated flow @ 35 bar [500 psi]	32 l/min [8.4 US gpm]
Leakage	5 drops/min max @ 210 bar [3000 psi]
Recommended PWM frequency	120 Hz
Maximum Hysteresis	15%
Maximum control current	1350-1450 mA [12 VDC coil] 675-725 mA [24 VDC coil]
Coil Options	S series
Weight	0.11 kg [0.24 lb]
Cavity	SDC08-2

*Rated pressure based on NFPA fatigue test standards (at 1 million cycles)

MODEL CODE

ESV1 - 8 - V - C - M - A - 2G - 12D - G - S

Seal Option

Code	Seal kit
Omit	Buna - N 02-165875
V	Viton 02-165877

Manual Override Option

Omit - No manual override
M - Knob type

Housing Material

Omit - No Housing
A - Aluminium

Housing

Code	Ports	Aluminium
0	No housing	
2G	1/4" BSP	02-160727
3G	3/8" BSP	02-160728
4T	#4 SAE	02-150730
6T	#6 SAE	02-160731
8T	#8 SAE	02-160732

* Aluminum bodies are to be used for pressures less than 210 bar [3000 psi].

* Additional housings available

DIMENSIONS

mm [in]

Coil Nut Torque
9-13 Nm (7-10 ft. lbs)

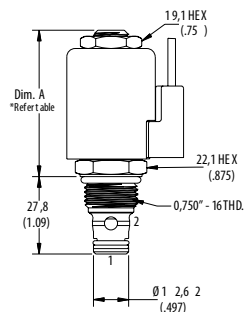

Installation torque
A - 34-41 Nm [25-30 ft. lbs]

PERFORMANCE CURVES

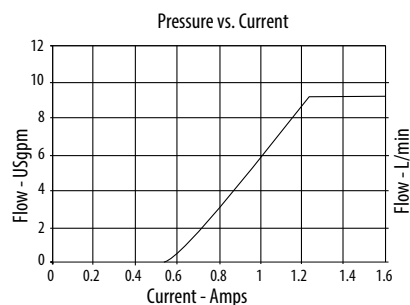
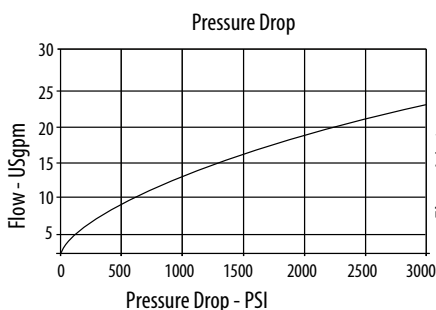

Proportional Valves

ESV1-10-C

Proportional Flow Control Valve, Poppet Type, Normally Closed, Pilot Operated, Non-Compensated

210 bar [3000 psi] • 70 l/min [18.5 US gpm]

DESCRIPTION AND OPERATION

This is a 2-way, poppet type, normally closed, pilot operated non-compensated proportional valve. In the de-energized condition, flow is blocked from port 2 to 1 but free flow from port 1 to 2. Energizing the coil will proportionally lift the poppet off its seat opening port 2 to 1, while flow from port 1 to 2 will remain restricted. Used in conjunction with a compensator, the valve will act as the control orifice for a pressure compensated flow control. This valve is available with an optional manual override.

SCHEMATIC

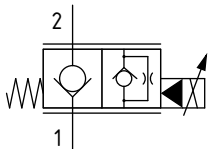

PERFORMANCE DATA

Rated pressure*	210 bar [3000 psi]
Rated flow @ 35 bar [500 psi]	70 l/min [18.5 US gpm]
Leakage	5 drops/min max @ 210 bar [3000 psi]
Recommended PWM frequency	120 Hz
Maximum Hysteresis	15%
Maximum control current	900-1000 mA [12 VDC coil] 450-500 mA [24 VDC coil]
Coil Options	J series
Weight	0.13 kg [0.28 lb]
Cavity	SDC10-2

*Rated pressure based on NFPA fatigue test standards (at 1 million cycles)

MODEL CODE

ESV1 - 10 - V - C - M - A - 2G - 12D - G - J

Seal Option

Code	Seal kit
Omit - Buna - N	565803
V - Viton	566086

Manual Override Option

Omit - No manual override
M - Knob type

Housing Material

Omit - No housing
A - Aluminium

Housing

Code	Ports	Aluminium
0	No housing	
2G	1/4" BSP	02-160727
3G	3/8" BSP	02-160728
4T	#4 SAE	02-150730
6T	#6 SAE	02-160731
8T	#8 SAE	02-160732

* Aluminium bodies are to be used for pressures less than 210 bar [3000 psi].

* Additional housings available

DIMENSIONS

mm [in]

Coil Nut Torque
9-13 Nm (7-10 ft lbs)

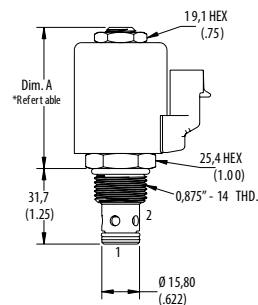

Installation torque
A - 47-54 Nm [35-40 ft. lbs]

PERFORMANCE CURVES

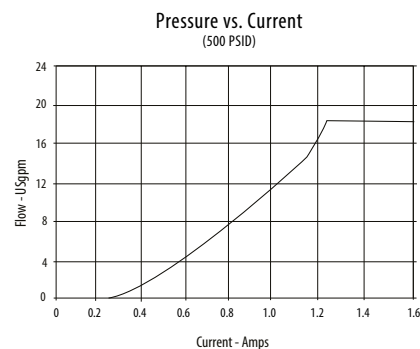
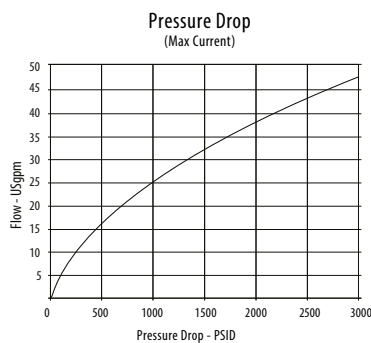

Coil series

Omit - No coil
J - J series, 20W

Connector Type

Omit - No coil
G - ISO 4400 DIN 43650
Q - Spade terminals
W - Flying lead
N - Deutsch (DC only)
Y - Amp JR (DC only)
D - Metripack 150 male (DC only)
J - Metripack 280 male (DC only)

Coil Voltage

0D - No coil, nut included (p/n 565558)
12D - 12VDC
24D - 24VDC

Proportional Valves

PSVP10-NCR

Proportional Flow Control Valve, Poppet Type, Normally Closed, Pilot Operated, Non-Compensated

260 bar [3800 psi] • 100 l/min [26 US gpm]

DESCRIPTION AND OPERATION

This is a 2-way, poppet type, normally closed, pilot operated non-compensated proportional valve. In the de-energized condition, flow is blocked from port 2 to 1 but free flow from port 1 to 2. Energizing the coil will proportionally lift the poppet off its seat opening port 2 to 1, while flow from port 1 to 2 will remain restricted. Used in conjunction with a compensator, the valve will act as the control orifice for a pressure compensated flow control.

SCHEMATIC

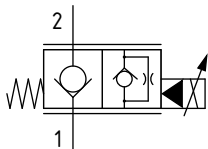

DIMENSIONS

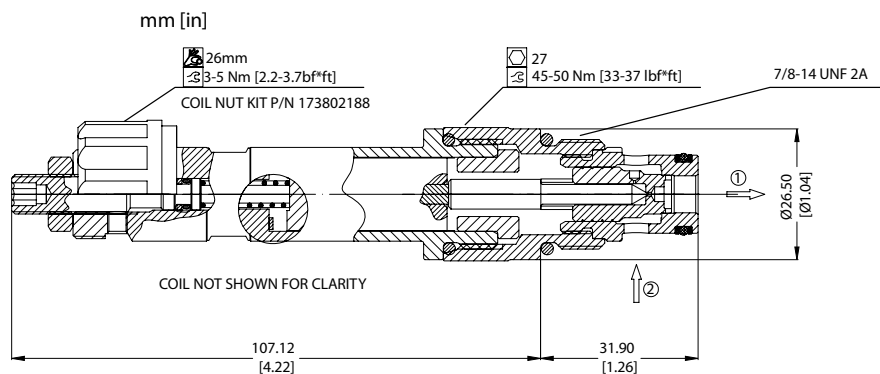

PERFORMANCE DATA

Rated pressure*	260 bar [3800 psi]
Rated flow @ 35 bar [500 psi]	100 l/min [26 US gpm]
Leakage	6 drops/min @rated pressure
Maximum Hysteresis	8%
Threshold current	0.8 A [12 VDC coil] 0.4 A [24 VDC coil]
Maximum control current	1.8 A [12 VDC coil] 0.9 A [24 VDC coil]
Coil Options	M19P
Weight	0.54 kg [1.19 lb]
Cavity	SDC10-2

*Rated pressure based on NFPA fatigue test standards (at 1 million cycles)

PERFORMANCE CURVES

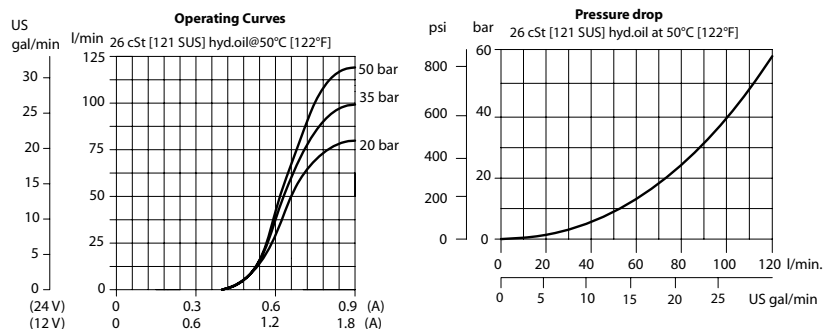

MODEL CODE

PSVP10 - NCR - 12D - DE - B - 00

Coil Voltage

00 - No coil, nut included*
12D - 12 VDC
24D - 24 VDC

*Standard Coil - Plastic coil nut and o-rings (p/n 173802188)

Connector Type

00 - No coil
AJ - AMP Junior
DE - Deutsch
DN - DIN 43650
FL - Flying Leads

Housing

Code	Ports & Material	Housing Model Code
00	No Housing	
6S	AL #6 SAE	CP10-2-6S
8S	AL #8 SAE	CP10-2-8S
DG3B	AL, 3/8 BSP	SDC10-2-DG3B
DG4B	AL, 1/2 BSP	SDC10-2-DG4B

* Aluminum bodies are to be used for pressures less than 210 bar [3000 psi].

* Additional housings available

Seal Option

Code	Seal kit
B - Buna - N	354004019
V - Viton	354003419

Proportional Valves

ESV1-12-C

Proportional Flow Control Valve, Poppet Type, Normally Closed, Pilot Operated, Non-Compensated

210 bar [3000 psi] • 103 l/min [27.3 US gpm]

DESCRIPTION AND OPERATION

This is a 2-way, poppet type, normally closed, pilot operated non-compensated proportional valve. In the de-energized condition, flow is blocked from port 2 to 1 but free flow from port 1 to 2. Energizing the coil will proportionally lift the poppet off its seat opening port 2 to 1, while flow from port 1 to 2 will remain restricted. Used in conjunction with a compensator, the valve will act as the control orifice for a pressure compensated flow control.

SCHEMATIC

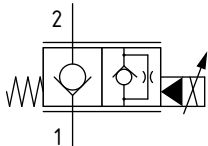

PERFORMANCE DATA

Rated pressure*	210 bar [3000 psi]
Rated flow @ 35 bar [500 psi]	103 l/min [27.3 US gpm]
Leakage	5 drops/min max @ 3000 psi
Recommended PWM frequency	120 Hz
Maximum Hysteresis	15%
Maximum control current	1150-1250 mA [12VDC coil] 525-625 mA [24 VDC coil]
Coil Options	J series
Weight	0.23 kg [0.48 lb]
Cavity	C-12-2/C-12-2U

*Rated pressure based on NFPA fatigue test standards (at 1 million cycles)

MODEL CODE

ESV1 - 12 - V - C - A - 4G - U - 12D - G - J

Seal Option

Code	Seal kit
Omit - Buna - N	02-165875
V - Viton	02-165877

Housing Material

Omit - No housing
A - Aluminium

Housing

Code	Ports	Aluminium	Aluminium (C-12-2U)
0	No housing		
4G	1/2" BSP	02-161118	02-161116
6G	3/4" BSP	02-161117	02-161115
10T	#10 SAE	02-160640	02-160641
12T	#12 SAE	02-160644	02-160645

* Aluminium bodies are to be used for pressures less than 210 bar [3000 psi].
* Additional housings available

Cavity

Omit - No undercut/No housing
U - Undercut (C-12-2U)

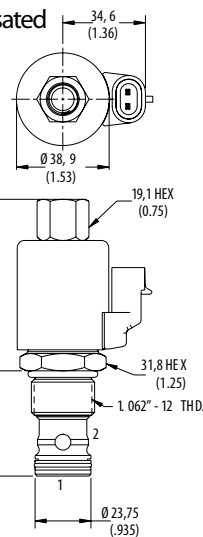

DIMENSIONS

mm [in]

Coil Nut Torque
9-13 Nm (7-10 ft lbs)

Installation torque
A - 81-95 Nm [60-70 ft. lbs]

PERFORMANCE CURVES

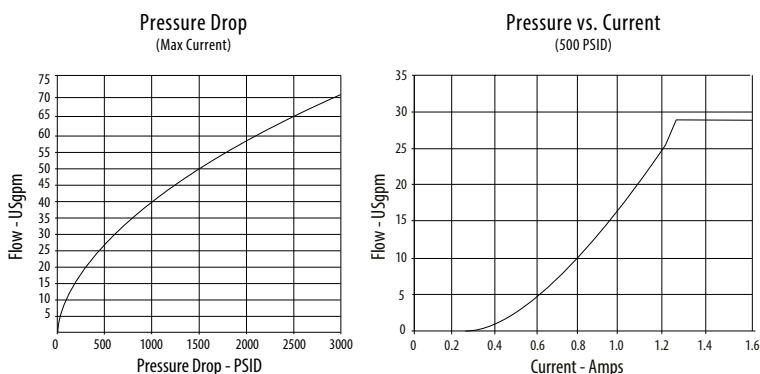

Coil series

Omit - No coil
J-J series, 23W

Connector Type

Omit - No coil
G - ISO 4400 DIN 43650
Q - Spade terminals
W - Flying lead
N - Deutsch (DC only)
Y - Amp JR (DC only)
D - Metripack 150 male (DC only)
J - Metripack 280 male (DC only)

Coil Voltage

00 - No coil, nut included (p/n 565558)
12D - 12VDC
24D - 24VDC

Proportional Valves

PSVP12-NCR

Proportional Flow Control Valve, Poppet Type, Normally Closed, Pilot Operated, Non-Compensated

260 bar [3800 psi] • 120 l/min [32 US gpm]

DESCRIPTION AND OPERATION

This is a 2-way, poppet type, normally closed, pilot operated non-compensated proportional valve. In the de-energized condition, flow is blocked from port 2 to 1 but free flow from port 1 to 2. Energizing the coil will proportionally lift the poppet off its seat opening port 2 to 1, while flow from port 1 to 2 will remain restricted. Used in conjunction with a compensator, the valve will act as the control orifice for a pressure compensated flow control.

SCHEMATIC

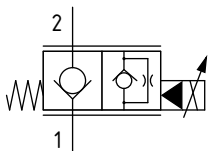

DIMENSIONS

mm [in]

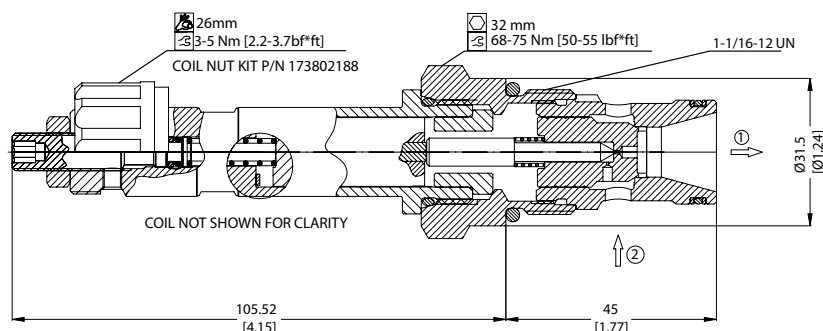

PERFORMANCE DATA

Rated pressure*	260 bar [3800 psi]
Rated flow @ 35 bar [500 psi]	120 l/min [32 US gpm]
Leakage	6 drops/min @rated pressure
Maximum Hysteresis	8%
Threshold current	0.6 [12 VDC coil] 0.3 [24 VDC coil]
Maximum control current	1.8 [12 VDC coil] 0.9 [24 VDC coil]
Coil Options	M19P
Weight	0.60 kg [1.32 lb]
Cavity	SDC12-2

*Rated pressure based on NFPA fatigue test standards (at 1 million cycles)

PERFORMANCE CURVES

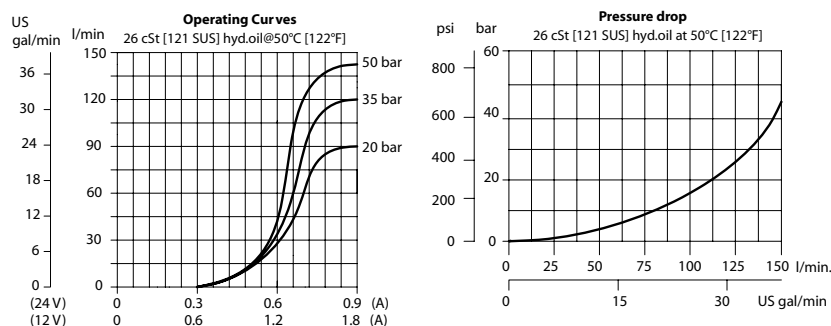

MODEL CODE

PSVP12 - NCR - 12D - DE - B - 00

Coil Voltage

00 - No coil, nut included*
12D - 12 VDC
24D - 24 VDC

*Standard Coil - Plastic coil nut and o-rings (p/n 173802188)

Connector Type

00 - No coil
AJ - AMP Junior
DE - Deutsch
DN - DIN 43650

Housing

Code	Ports & Material	Housing Model Code
00	No Housing	
105	AL #10 SAE	CP12-2-105
125	AL #12 SAE	CP12-2-125
DG4B	AL, 1/2 BSP	SDC12-2-DG4B
DG6B	AL, 3/4 BSP	SDC12-2-DG6B

* Aluminum bodies are to be used for pressures less than 210 bar [3000 psi].

* Additional housings available

Seal Option

Code	Seal kit
B - Buna - N	354008319
V - Viton	354008419

Proportional Valves

PSVP16-NCR

Proportional Flow Control Valve, Poppet Type, Normally Closed, Pilot Operated, Non-Compensated

260 bar [3800 psi] • 176 l/min [46 US gpm]

DESCRIPTION AND OPERATION

This is a 2-way, poppet type, normally closed, pilot operated non-compensated proportional valve. In the de-energized condition, flow is blocked from port 2 to 1 but free flow from port 1 to 2. Energizing the coil will proportionally lift the poppet off its seat opening port 2 to 1, while flow from port 1 to 2 will remain restricted. Used in conjunction with a compensator, the valve will act as the control orifice for a pressure compensated flow control.

SCHEMATIC

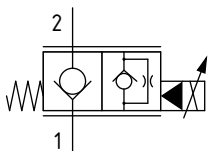

DIMENSIONS

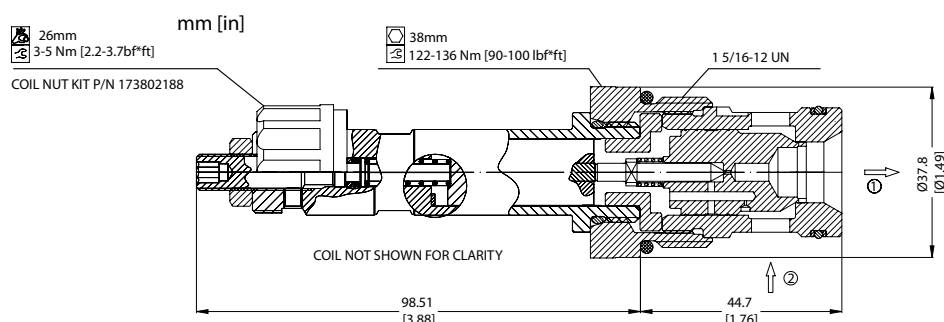

PERFORMANCE DATA

Rated pressure*	260 bar [3800 psi]
Rated flow @ 35 bar [500 psi]	176 l/min [46 US gpm]
Leakage	6 drops/min @ rated pressure
Maximum Hysteresis	8%
Threshold current	0.8 [12 VDC coil] 0.4 [24 VDC coil]
Maximum control current	1.8 [12 VDC coil] 0.9 [24 VDC coil]
Coil Options	M19P
Weight	0.85 kg [1.87 lb]
Cavity	SDC16-2

*Rated pressure based on NFPA fatigue test standards (at 1 million cycles)

PERFORMANCE CURVES

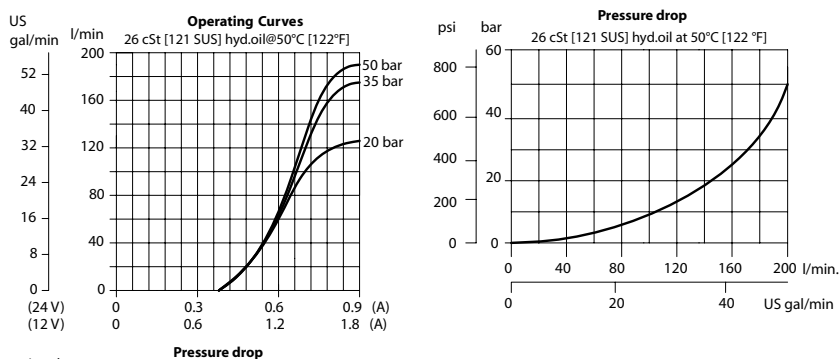

MODEL CODE

PSVP16 - NCR - 12D - DE - B - 00

Coil Voltage

00 - No coil, nut included*
12D - 12 VDC
24D - 24 VDC

*Standard Coil - Plastic coil nut and o-rings (p/n 173802188)

Connector Type

00 - No coil
AJ - AMP Junior
DE - Deutsch
DN - DIN 43650

Housing

Code	Ports & Material	Housing Model Code
00	No Housing	
DG6B	AL, 3/4 BSP	SDC16-2-DG-6B
DG8B	AL, 1 BSP	SDC16-2-DG-8B
12S	AL, #12 SAE	CP16-2-12S
16S	AL, #16 SAE	CP16-2-16S

* Aluminum bodies are to be used for pressures less than 210 bar [3000 psi].

* Additional housings available

Seal Option

Code	Seal kit
B - Buna - N	354008719
V - Viton	354008819

Proportional Valves

ESV1-8-O

Proportional Flow Control Valve, Poppet Type, Normally Open, Pilot Operated, Non-Compensated

210 bar [3000 psi] • 32 l/min [8.4 US gpm]

DESCRIPTION AND OPERATION

This is a 2-way, poppet type, normally open, pilot operated non compensated proportional valve. In the de-energized condition, flow passes from port 2 to 1 but is restricted from port 1 to 2. Energizing the coil will proportionally push the poppet towards the seat closing port 2 to 1, while allowing free flow from port 1 to 2. Used in conjunction with a compensator, the valve will act as the control orifice for a pressure compensated flow control.

SCHEMATIC

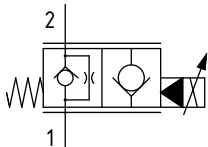

PERFORMANCE DATA

Rated pressure*	210 bar [3000 psi]
Rated flow @ 35 bar [500 psi]	32 l/min [8.4 US gpm]
Leakage	5 drops/min @ 210 bar [3000 psi]
Recommended PWM frequency	120 Hz
Maximum Hysteresis	15%
Maximum control current	1100-1250 mA [12 VDC coil] 500-625 mA [24 VDC coil]
Coil Options	S series
Weight	0.11 kg [0.24 lb]
Cavity	SDC08-2

*Rated pressure based on NFPA fatigue test standards (at 1 million cycles)

MODEL CODE

ESV1 - 8 - V - O - M - A - 2G - 12D - G - S

Seal Option

Code	Seal kit
Omit	Buna - N 9900171-000
V	Viton 9900172-000

Manual Override Option

Omit - No manual override
M - Knob type

Housing Material

Omit - No housing
A - Aluminium

Housing

Code	Ports	Aluminium
0	No housing	
2G	1/4" BSP	02-160727
3G	3/8" BSP	02-160728
4T	#4 SAE	02-150730
6T	#6 SAE	02-160731
8T	#8 SAE	02-160732

* Aluminium bodies are to be used for pressures less than 210 bar [3000 psi].

* Additional housings available

DIMENSIONS

mm [in]

Coil Nut Torque
9-13 Nm (7-10 ft lbs)

Installation torque
A - 34-41 Nm [25-30 ft. lbs]

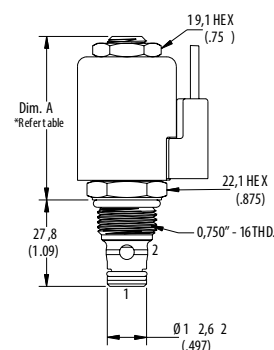

PERFORMANCE CURVES

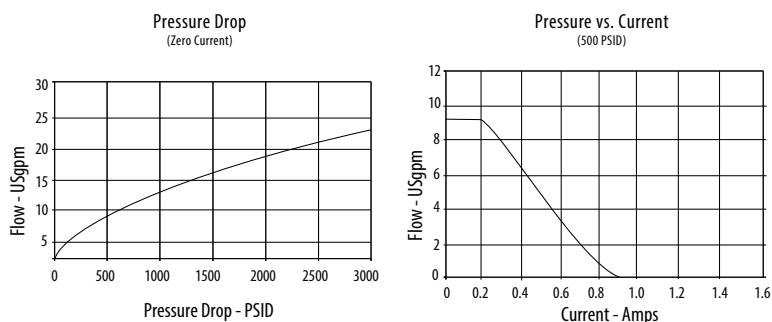

Proportional Valves

ESV1-10-O

Proportional Flow Control Valve, Poppet Type, Normally Open, Pilot Operated, Non-Compensated

210 bar [3000 psi] • 70 l/min [18.5 US gpm]

DESCRIPTION AND OPERATION

This is a 2-way, poppet type, normally open, pilot operated non compensated proportional valve. In the de-energized condition, flow passes from port 2 to 1 but is restricted from port 1 to 2. Energizing the coil will proportionally push the poppet towards the seat closing port 2 to 1, while allowing free flow from port 1 to 2. Used in conjunction with a compensator, the valve will act as the control orifice for a pressure compensated flow control.

SCHEMATIC

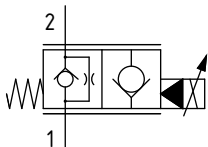

PERFORMANCE DATA

Rated pressure*	210 bar [3000 psi]
Rated flow @ 35 bar [500 psi]	70 l/min [18.5 US gpm]
Leakage	5 drops/min max @ 3000 psi
Recommended PWM frequency	120 Hz
Maximum Hysteresis	15%
Maximum control current	1000-1200 mA [12 VDC coil] 500-600 mA [24 VDC coil]
Coil Options	J series
Weight	0.13 kg [0.28 lb]
Cavity	SDC10-2

*Rated pressure based on NFPA fatigue test standards (at 1 million cycles)

MODEL CODE

ESV1 - 10 - V - O - M - A - 2G - 12D - G - J

Seal Option

Code	Seal kit
Omit - Buna - N	566086
V - Viton	566086

Manual Override Option

Omit - No manual override
M - Knob type

Housing Material

Omit - No housing
A - Aluminium

Housing

Code	Ports	Aluminium
0	No housing	
2G	1/4" BSP	02-160727
3G	3/8" BSP	02-160728
4T	#4 SAE	02-150730
6T	#6 SAE	02-160731
8T	#8 SAE	02-160732

* Aluminium bodies are to be used for pressures less than 210 bar [3000 psi].

* Additional housings available

Coil series

Omit - No coil
J - J series, 23W

Connector Type

Omit - No coil
G - ISO 4400 DIN 43650
Q - Spade terminals
W - Flying lead
N - Deutsch (DC only)
Y - Amp JR (DC only)
D - Metripack 150 male (DC only)
J - Metripack 280 male (DC only)

Coil Voltage

00 - No coil, nut included (p/n 565558)
12D - 12VDC
24D - 24VDC

DIMENSIONS

mm [in]

Coil Nut Torque
9-13 Nm (7-10 ft lbs)

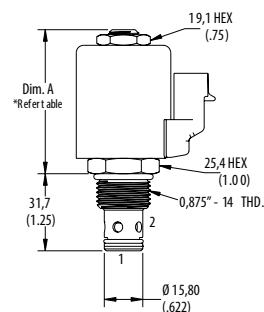

Installation torque
A - 47-54 Nm [35-40 ft. lbs]

PERFORMANCE CURVES

Pressure Drop
(Zero Current)

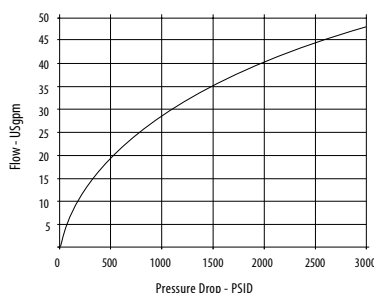

Pressure vs. Current
(500 PSID)

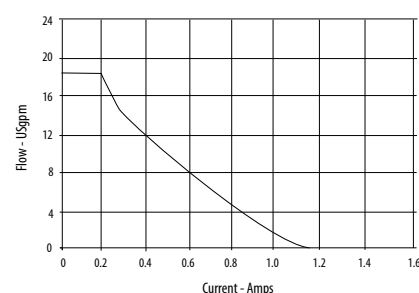

Proportional Valves

PSVP10-NOR

Proportional Flow Control Valve, Poppet Type, Normally Open, Pilot Operated, Non-Compensated

260 bar [3800 psi] • 100 l/min [26 US gpm]

DESCRIPTION AND OPERATION

This is a 2-way, poppet type, normally open, pilot operated non-compensated proportional valve. In the de-energized condition, flow passes from port 2 to 1 but is restricted from port 1 to 2. Energizing the coil will proportionally push the poppet towards the seat closing port 2 to 1, while allowing free flow from port 1 to 2. Used in conjunction with a compensator, the valve will act as the control orifice for a pressure compensated flow control.

SCHEMATIC

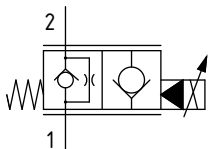

DIMENSIONS

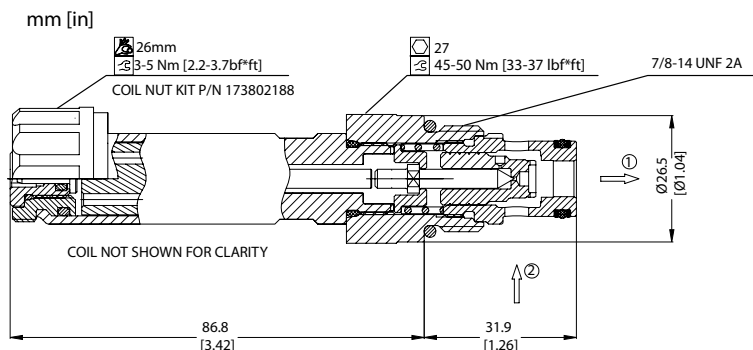

PERFORMANCE DATA

Rated pressure*	260 bar [3800 psi]
Rated flow @ 35 bar [500 psi]	100 l/min [26 US gpm]
Leakage	6 drops/min @Rated pressure
Maximum Hysteresis	8%
Threshold current	0 A
Maximum control current	1.0 [12 VDC coil] 0.5 [24 VDC coil]
Coil Options	M19P
Weight	0.54 kg [1.19 lb]
Cavity	SDC10-2

*Rated pressure based on NFPA fatigue test standards (at 1 million cycles)

PERFORMANCE CURVES

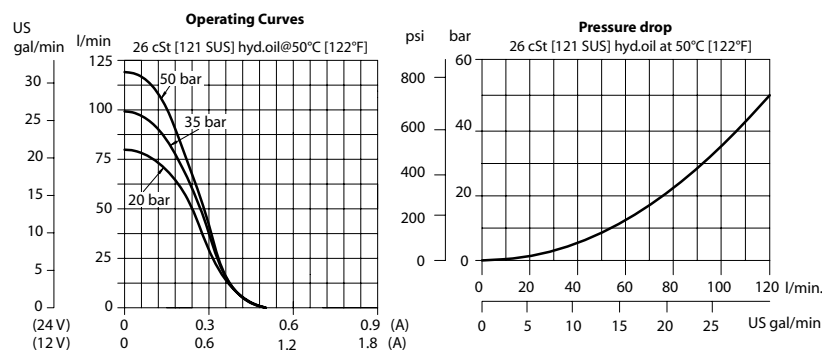

MODEL CODE

PSVP10 - NOR - 12D - DE - SPS - B - 00

Coil Voltage

00 - No coil, nut included*
12D - 12 VDC
24D - 24 VDC

*Standard Coil - Plastic coil nut and o-rings (p/n 173802188)

Connector Type

00 - No coil
AJ - AMP Junior
DE - Deutsch
DN - DIN 43650

Manual Override Option

Omit - Push Pin
SPS - Screw Type

Housing

Code	Ports & Material	Housing Model Code
00	No Housing	
65	AL, #6 SAE	CP10-2-65
85	AL, #8 SAE	CP10-2-85
DG3B	AL, 3/8 BSP	SDC10-2-DG3B
DG4B	AL, 1/2 BSP	SDC10-2-DG4B

* Aluminum bodies are to be used for pressures less than 210 bar [3000 psi].
* Additional housings available

Seal Option

Code	Seal kit
B - Buna - N	354004019
V - Viton	354003419

Proportional Valves

ESV1-12-O

Proportional Flow Control Valve, Poppet Type, Normally Open, Pilot Operated, Non-Compensated

210 bar [3000 psi] • 103 l/min [27.3 US gpm]

DESCRIPTION AND OPERATION

This is a 2-way, poppet type, normally open, pilot operated non compensated proportional valve. In the de-energized condition, flow passes from port 2 to 1 but is restricted from port 1 to 2. Energizing the coil will proportionally push the poppet towards the seat closing port 2 to 1, while allowing free flow from port 1 to 2. Used in conjunction with a compensator, the valve will act as the control orifice for a pressure compensated flow control.

SCHEMATIC

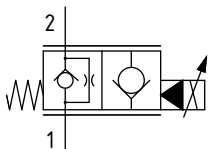

DIMENSIONS

mm [in]

Coil Nut Torque

9-13 Nm (7-10 ft lbs)

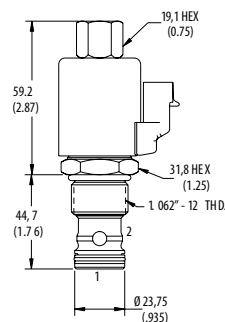

Installation torque

81-95 Nm [60-70 ft lbs]

PERFORMANCE DATA

Rated pressure*	210 bar [3000 psi]
Rated flow @ 35 bar [500 psi]	103 l/min [27.3 US gpm]
Leakage	5 drops/min max @ 3000 psi
Recommended PWM frequency	120 Hz
Maximum Hysteresis	15%
Maximum control current	1150-1250 mA [12V coil] 525-625 mA [24V coil]
Coil Options	J series
Weight	0.24 kg [0.23 lb]
Cavity	C-12-2/C-12-2U

*Rated pressure based on NFPA fatigue test standards (at 1 million cycles)

PERFORMANCE CURVES

Pressure Drop

(Zero Current)

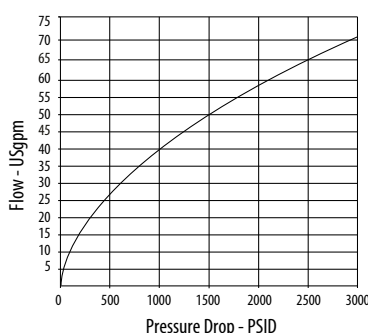

Pressure vs. Current

(500 PSID)

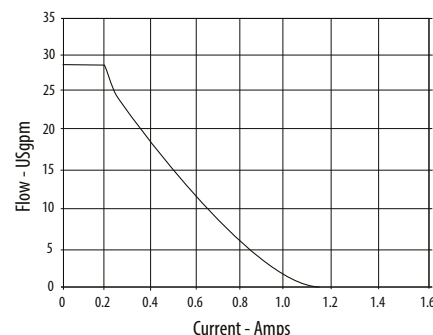

MODEL CODE

ESV1 - 12 - V - O - A - 4G - U - 12D - G - J

Seal Option

Code **Seal kit**

Omit - Buna - N 02-165889

V - Viton 02-165888

Housing Material

Omit - No housing

A - Aluminium

Housing

Code	Ports	Aluminium	Aluminium (C-12-2U)
0	No housing		
4G	1/2" BSP	02-161118	02-161116
6G	3/4" BSP	02-161117	02-161115
10T	#10 SAE	02-160640	02-160641
12T	#12 SAE	02-160644	02-160645

* Aluminium bodies are to be used for pressures less than 210 bar [3000 psi].

* Additional housings available

Cavity

Omit - No undercut/No housing

U - Undercut (C-12-2U)

Coil series

Omit - No coil

J - S Series, 23 W

Connector Type

Omit - No coil

G - ISO 4400 DIN 43650

W - Flying lead

N - Deutsch (DC only)

Y - Amp JR (DC only)

D - Metripack 150 male (DC only)

J - Metripack 280 male (DC only)

Coil Voltage

00 - No coil, nut included (p/n 565558)

12D - 12VDC

24D - 24VDC

Proportional Valves

PSVP12-NOR

Proportional Flow Control Valve, Poppet Type, Normally Open, Pilot Operated, Non-Compensated

260 bar [3800 psi] • 120 l/min [32 US gpm]

DESCRIPTION AND OPERATION

This is a 2-way, poppet type, normally open, pilot operated non-compensated proportional valve. In the de-energized condition, flow passes from port 2 to 1 but is restricted from port 1 to 2. Energizing the coil will proportionally push the poppet towards the seat closing port 2 to 1, while allowing free flow from port 1 to 2. Used in conjunction with a compensator, the valve will act as the control orifice for a pressure compensated flow control.

SCHEMATIC

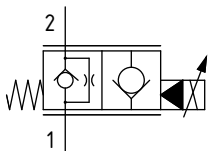

DIMENSIONS

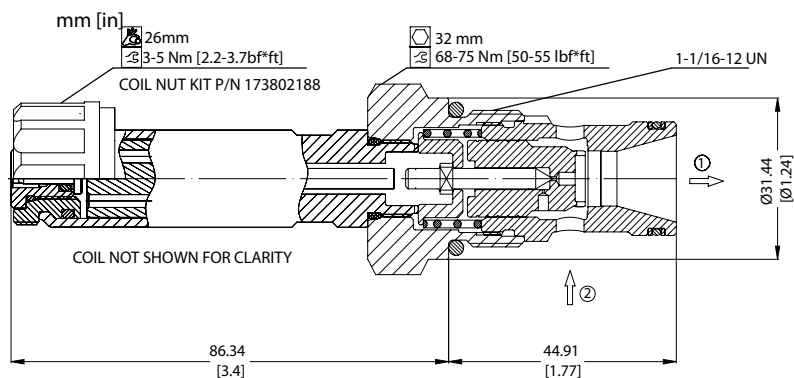

PERFORMANCE DATA

Rated pressure*	260 bar [3800 psi]
Rated flow @ 35 bar [500 psi]	120 l/min [32 US gpm]
Leakage	6 drops/min @Rated pressure
Maximum Hysteresis	8%
Threshold current	0 A
Maximum control current	1.3 A [12 VDC coil] 0.65 A [24 VDC coil]
Coil Options	M19P
Weight	0.60 kg [1.32 lb]
Cavity	SDC12-2

*Rated pressure based on NFPA fatigue test standards (at 1 million cycles)

PERFORMANCE CURVES

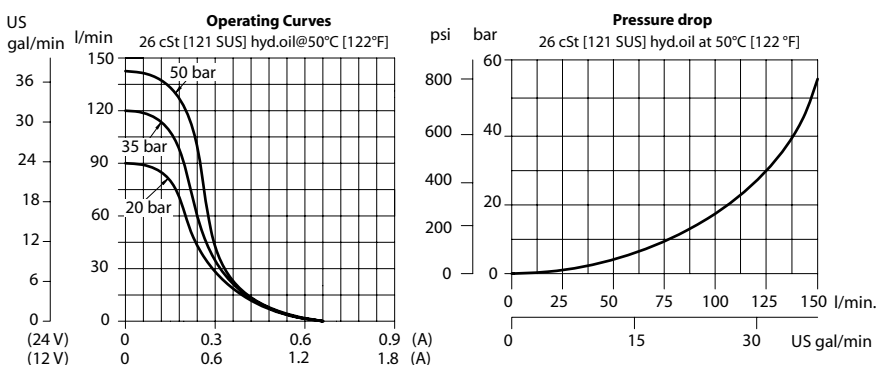

MODEL CODE

PSVP12 - NOR - 12D - DE - SPS - B - 00

Coil Voltage

00 - No coil, nut included*
12D - 12 VDC
24D - 24 VDC

*Standard Coil - Plastic coil nut and o-rings (p/n 173802188)

Connector Type

00 - No coil
AJ - AMP Junior
DE - Deutsch
DN - DIN 43650

Manual Override Option

Omit - Push Pin
SPS - Screw Type

Housing

Code	Ports & Material	Housing Model Code
00	No Housing	
10S	AL, #10 SAE	CP12-2-10S
12S	AL, #12 SAE	CP12-2-12S
DG4B	AL, 1/2 BSP	SDC12-2-DG4B
DG6B	AL, 3/4 BSP	SDC12-2-DG6B

* Aluminum bodies are to be used for pressures less than 210 bar [3000 psi].
* Additional housings available

Seal Option

Code	Seal kit
B - Buna - N	354008319
V - Viton	354008419

Proportional Valves

PSVP16-NOR

Proportional Flow Control Valve, Poppet Type, Normally Open, Pilot Operated, Non-Compensated

260 bar [3800 psi] • 165 l/min [44 US gpm]

DESCRIPTION AND OPERATION

This is a 2-way, poppet type, normally open, pilot operated non-compensated proportional valve. In the de-energized condition, flow passes from port 2 to 1 but is restricted from port 1 to 2. Energizing the coil will proportionally push the poppet towards the seat closing port 2 to 1, while allowing free flow from port 1 to 2. Used in conjunction with a compensator, the valve will act as the control orifice for a pressure compensated flow control.

SCHEMATIC

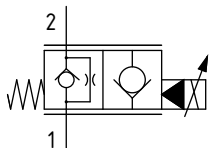

DIMENSIONS

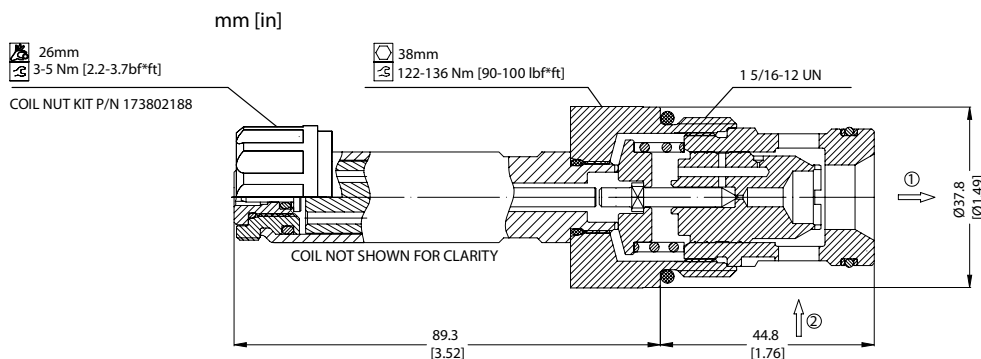

PERFORMANCE DATA

Rated pressure*	260 bar [3800 psi]
Rated flow @ 35 bar [500 psi]	165 l/min [44 US gpm]
Leakage	6 drops/min @Rated pressure
Maximum Hysteresis	8%
Threshold current	0 A
Maximum control current	1.0 A [12 VDC coil] 0.5 A [24 VDC coil]
Coil Options	M19P
Weight	0.85 kg [1.87 lb]
Cavity	SDC16-2

*Rated pressure based on NFPA fatigue test standards (at 1 million cycles)

PERFORMANCE CURVES

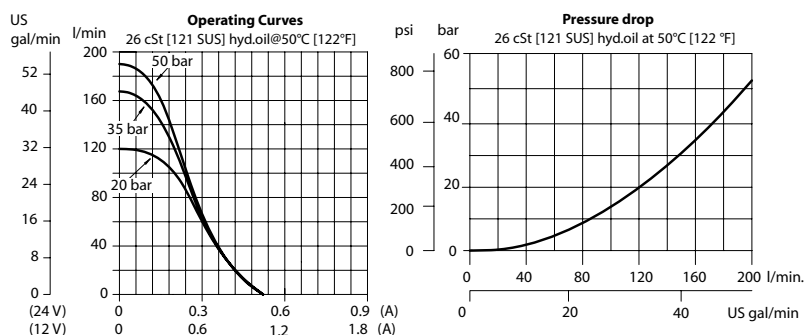

MODEL CODE

PSVP16 - NOR - 12D - DE - SPS - B - 00

Coil Voltage

00 - No coil, nut included*
12D - 12 VDC
24D - 24 VDC

*Standard Coil - Plastic coil nut and o-rings (p/n 173802188)

Connector Type

00 - No coil
AJ - AMP Junior
DE - Deutsch
DN - DIN 43650

Manual Override Option

Omit - Push Pin
SPS - Screw Type

Housing

Code	Ports & Material	Housing Model Code
00	No Housing	
DG6B	AL, 3/4 BSP	SDC16-2-DG-6B
DG8B	AL, 1 BSP	SDC16-2-DG-8B
12S	AL, #12 SAE	CP16-2-12S
16S	AL, #16 SAE	CP16-2-16S

* Aluminum bodies are to be used for pressures less than 210 bar [3000 psi].
* Additional housings available

Seal Option

Code	Seal kit
B - Buna - N	354008719
V - Viton	354008819

Proportional Valves

EPV10

Proportional Flow Control Valve, Poppet Type, Normally Closed, Uni-Directional, Pressure Compensated

350 bar [5000 psi] • 30 l/min [8 US gpm]

DESCRIPTION AND OPERATION

This is a 2-way, poppet type, normally closed, pressure compensated, uni-directional proportional valve. In the de-energized condition, flow is blocked from port 2 to 1. Energizing the coil will proportionally push the poppet away from its seat opening port 2 to 1. This valve is ideal as a lowering valve for single acting cylinders.

SCHEMATIC

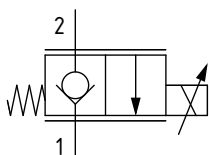

PERFORMANCE DATA

Rated pressure*	350 bar [5000 psi]
Rated flow	30 l/min [8 US gpm]
Leakage	10 ml/min @ 140 bar [2000 psi]
Maximum Hysteresis	4%
Recommended PWM frequency	100-200 Hz
Threshold current	300 - 600 mA [12 VDC coil] 150 - 300 mA [24 VDC coil]
Maximum control current	1.4 A [12 VDC coil] 0.7 A [24 VDC coil]
Coil Options	EPV series
Weight	0,78 kg [1.72 lbs]
Cavity	SDC10-2

*Rated pressure based on NFPA fatigue test standards (at 1 million cycles)

PERFORMANCE CURVES

Step response data

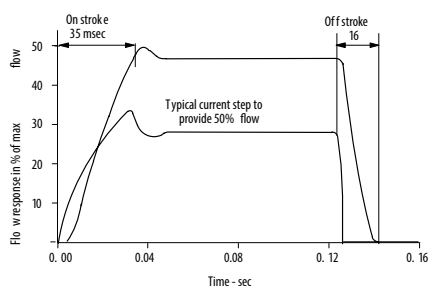

Flow vs current

With 10 bar differential between inlet and outlet

A - 210 bar (3000 psi) pressure drop from Port 2 to Port 1

B - 10 bar (150 psi) pressure drop from Port 2 to Port 1

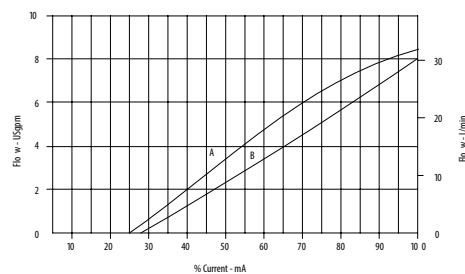

Flow vs pressure drop

Per % of input current

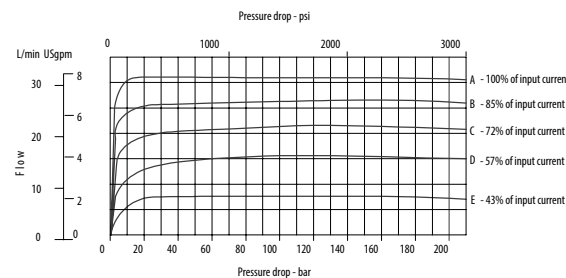

Typical flow response

For an amplitude of $\pm 40\%$ maximum stroke (center to offset) about the 50% position.

$\Delta P = 10$ bar (145 psi)

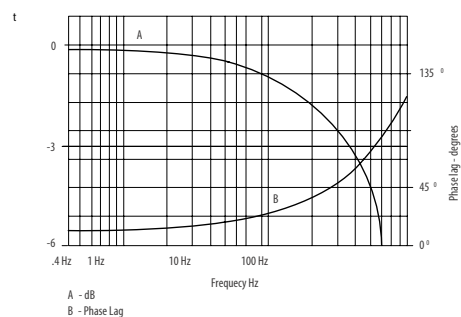

Proportional Valves

EPV10

Proportional Flow Control Valve, Poppet Type, Normally Closed, Uni-Directional, Pressure Compensated

350 bar [5000 psi] • 30 l/min [8 US gpm]

■ DIMENSIONS

mm [in]

Coil nut torque

2.5-3.0 Nm [22-27 in-lbs]

Installation torque

A - 47-54 Nm [35-40 ft lbs]

S - 68 - 75 Nm [50 - 55 ft. lbs.]

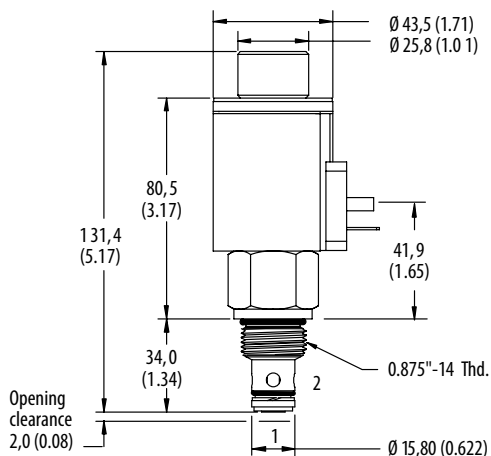

■ MODEL CODE

EPV10 - A - 0 - V - 12D - M - N - 10

Housing Material

Omit - No housing
A - Aluminum
S - Steel

Housing

Code	Ports	Aluminium	Steel
0	No housing		
3G	3/8" BSP	876703	02-175103
6H	#6 SAE	876700	02-175100
8H	#8 SAE	876701	02-175101

* Aluminum bodies are to be used for pressures less than 210 bar [3000 psi].
 * Additional housings available

Seal Option

Code	Seal Kit
Omit - Buna - N	02-317580
V - Viton	
NF - Buna - N and 60 mesh filter screen	
VF - Viton and 60 mesh filter screen	

Connector Type

0 - No coil
W - Leadwire (DC only)
U - DIN 43650
Y - Metri-Pack 150 male
N - Deutsch DT04-2P

Manual Override Option

0 - No manual override
M - Pin type
S - Screw type

Coil Voltage

00 - No coil, nut included (p/n 02-148332)
12D - 12VDC
24D - 24VDC

*Use EPV series, 16W coils

Proportional Valves

EPV16-A

Proportional Flow Control Valve, Poppet Type, Normally Closed, Pilot Operated, Pressure Compensated

280 bar [4000 psi] • 160 l/min [42 US gpm]

DESCRIPTION AND OPERATION

This is a 2-way, poppet type, normally closed, pressure compensated proportional flow control valve. In the de-energized condition, flow is blocked from port 1 to 2, while allowing free flow from port 2 to 1. Energizing the coil will proportionally open port 1 to 2, and the flow will remain constant irrespective of changes in pressure differential across the valve.

SCHEMATIC

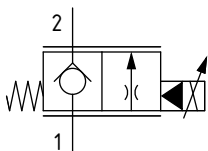

PERFORMANCE DATA

Rated pressure*	280 bar [4000 psi]
Rated flow	160 l/min [42 US gpm]
Leakage	50 ml/min @ 140 bar [2000 psi]
Maximum Hysteresis	4%
Recommended PWM frequency	100-200 Hz
Threshold current	350-600 mA [12 VDC coil] 175-250 mA [24 VDC coil]
Maximum control current	1.4 A [12 VDC coil] 0.7A [24 VDC coil]
Coil Options	EPV series
Weight	1 kg [2.2 lb]
Cavity	C-16-3SU

*Rated pressure based on NFPA fatigue test standards (at 1 million cycles)

PERFORMANCE CURVES

Pressure drop curves

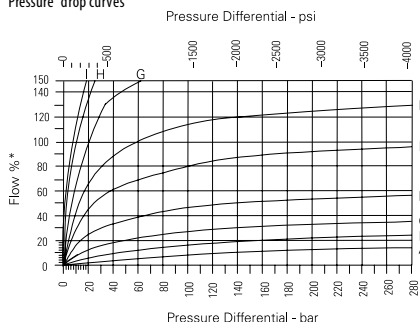

* Flow interims of % for each poppet size

Command current	12 V	24V
A-	60.0 mA	300mA
B-	70.0 mA	350mA
C-	80.0 mA	400mA
D-	90.0 mA	450mA
E-	1000 mA	500mA
F-	1100 mA	550mA
G-	1200 mA	600mA
H-	1300 mA	650mA
I-	1400 mA	700mA

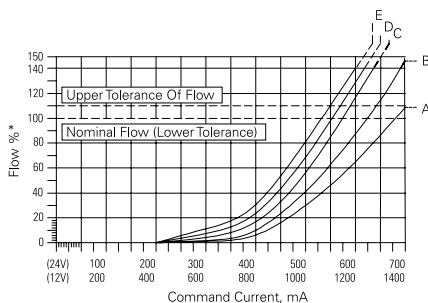

* Flow interims of % for each poppet size

Pressure differential	
A-	10 bar/ 50 psi
B-	20 bar / 300 psi
C-	50 bar / 700 psi
D-	10.0 bar / 150.0 psi
E-	200 bar / 3000 psi

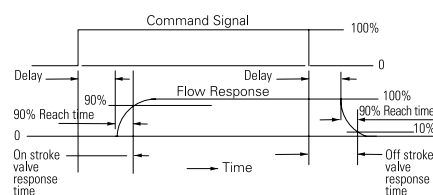

Pressure drop @ 120 L/min (30 USgpm)

Pressure drop DP	On stroke Delay/reach 90%	Off stroke delay/ reach 90%
20 bar (290 psi)	24 ms /35 ms	5 ms/15 ms
10.0 bar (145.0 psi)	24 ms/17 ms	5 ms/7 ms

Proportional Valves

EPV16-A

Proportional Flow Control Valve, Poppet Type, Normally Closed, Pilot Operated, Pressure Compensated

280 bar [4000 psi] • 160 l/min [42 US gpm]

DIMENSIONS

mm [in]

Coil Nut Torque

2.5-3.0 Nm [22-27 in lbs]

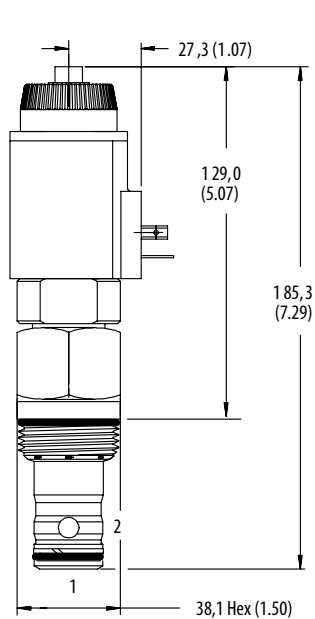

With Manual Override

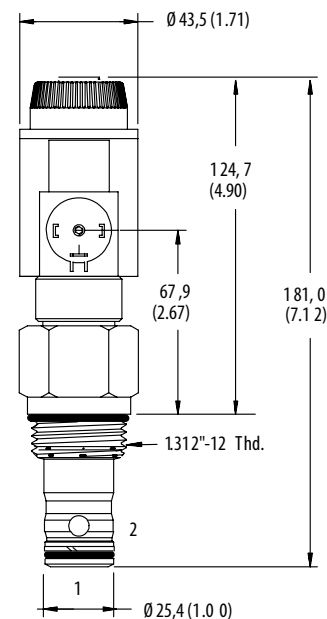

No manual override

Installation torque

A - 108-122 Nm [80-90 ft. lbs]

S - 136-149 Nm [100-110 ft. lbs]

*Port 3 of the C-16-3SU cavity is to be plugged

MODEL CODE

EPV16 - A - 04 - A - 4G - N - 12D - M - N - 13

Max Regulated Flow

Code	Flow
04	40 l/min (10.5 US gpm)
06	60 l/min (16 US gpm)
10	100 l/min (26 US gpm)
16	160 l/min (42 US gpm)

Housing Material

Omit - No housing
A - Aluminium
S - Steel

Housing

Code	Ports	Aluminium	Steel
0	No housing		
4G	1/2" BSP	02-185448	02-180050
6G	3/4" BSP	02-185449	02-180051
10H	#10 SAE	02-185450	02-180048
12H	#12 SAE	02-185447	02-180049

* Aluminium bodies are to be used for pressures less than 210 bar [3000 psi].

* Additional housings available

Seal Option

Code	Seal Kit
N	Buna - N (standard) 02-154069
V	Viton 1203263
NF	Buna - N and 60 mesh filter screen
VF	Viton and 60 mesh filter screen

Connector Type

O - No coil
W - Flying lead
N - Deutsch (DT04-2P)
Y - Metripack 150 male
U - DIN 43650

Manual Override Option

Omit - No manual override
M - Pin type
S - Screw type

Coil Voltage

00 - No coil, nut included (p/n 02-148332)
12D - 12VDC
24D - 24VDC

*Use EPV series, 16W coils

Proportional Valves

EPV16-B

Proportional Flow Control Valve, Poppet Type, Normally Closed, Pilot Operated, Pressure Compensated

280 bar [4000 psi] • 160 l/min [42 US gpm]

DESCRIPTION AND OPERATION

This is a 2-way, poppet type, normally closed, pressure compensated proportional flow control valve. In the de-energized condition, flow is blocked from port 2 to 1, while allowing free flow from port 1 to 2. Energizing the coil will proportionally open port 2 to 1, and the flow will remain constant irrespective of changes in pressure differential across the valve.

SCHEMATIC

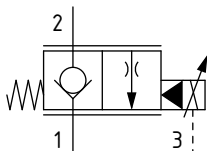

PERFORMANCE DATA

Rated pressure*	280 bar [4000 psi]
Rated flow	160 l/min [42 US gpm]
Max Regulated Flow	10 ml/min @ 140 bar [2000 psi]
Maximum Hysteresis	4%
Recommended PWM frequency	100-200 Hz
Threshold current	350-600 mA [12 VDC coil] 175-250 mA [24 VDC coil]
Maximum control current	1.4 A [12 VDC coil] 0.7 A [24 VDC coil]
Coil Options	EPV series
Weight	1 kg [2.2 lb]
Cavity	C-16-3SU

*Rated pressure based on NFPA fatigue test standards (at 1 million cycles)

PERFORMANCE CURVES

Pressure drop curves

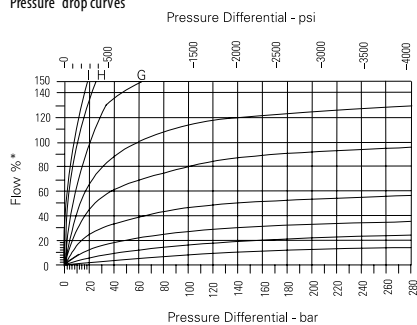

* Flow interims of % for each poppet size

Command current	12 V	24 V
A-	600 mA	300m A
B-	700 mA	350m A
C-	800 mA	400m A
D-	900 mA	450m A
E-	1000 mA	500m A
F-	1100 mA	550m A
G-	1200 mA	600m A
H-	1300 mA	650m A
I-	1400 mA	700m A

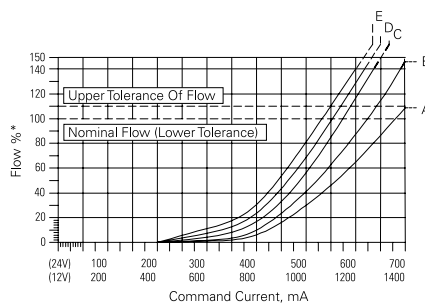

* Flow interims of % for each poppet size

Pressure differential		
A-	10 bar/1	50 psi
B-	20 bar	300 psi
C-	50 bar	700 psi
D-	100 bar	1500 psi
E-	200 bar	3000 psi

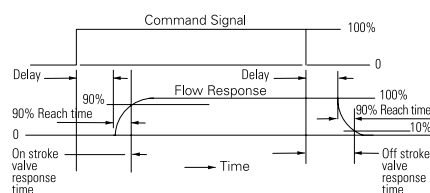

Pressure drop @ 120 L/min (30 USgpm)

Pressure drop DP	On stroke delay/reach 90%	Off stroke delay/reach 90%
20 bar (290 psi)	24 ms/35 ms	5 ms/15 ms
100 bar (1450 psi)	24 ms/17 ms	5 ms/7 ms

Proportional Valves

EPV16-B

Proportional Flow Control Valve, Poppet Type, Normally Closed, Pilot Operated, Pressure Compensated

280 bar [4000 psi] • 160 l/min [42 US gpm]

■ DIMENSIONS

mm [in]

Coil Nut Torque

2.5-3.0 Nm [22-27 ft in lbs]

Installation torque

A - 108-122 Nm [80-90 ft. lbs]

S - 136-149 Nm [100-110 ft. lbs]

*Port 3 must be connected to Port 1 externally to the cartridge, either by passages in the cavity block or external plumbing. When purchased with undercut body, this connection is included in the body and Port 3 is not machined.

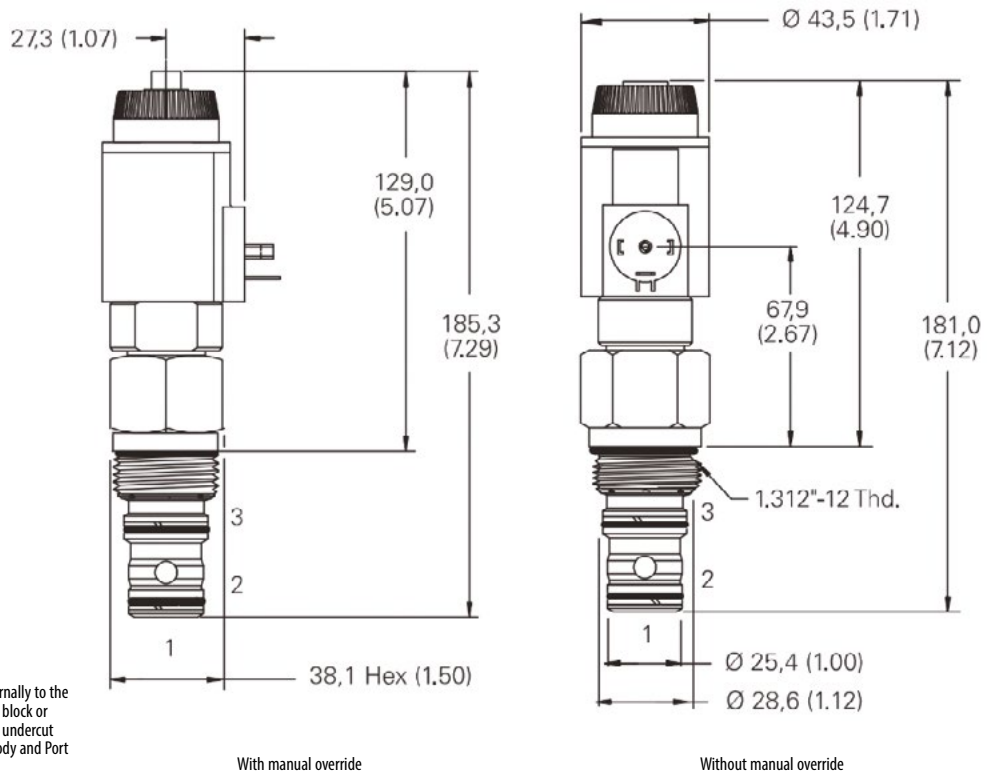

With manual override

Without manual override

■ MODEL CODE

EPV16 - B - 04 - A - 10H - N - 12D - M - N - 13

Max Regulated Flow

Code Flow

04	40 l/min (10.5 US gpm)
06	60 l/min (16 US gpm)
10	100 l/min (26 US gpm)
16	160 l/min (42 US gpm)

Housing Material

Omit - No housing
A - Aluminium
S - Steel

Housing

Code	Ports	Aluminium	Steel
0	No housing		
4G	1/2" BSP	02-166607	02-165500
6G	3/4" BSP	02-161592	02-164931
10H	#10 SAE	02-170238	02-161983
12H	#12 SAE	02-166609	02-161982

* Aluminum bodies are to be used for pressures less than 210 bar [3000 psi].

* Additional housings available

Connector Type

0 - No coil
W - Flying lead
N - Deutsch (DT04-2P)
Y - Metripack 150 male
U - DIN 43650

Manual Override Option

Omit - No manual override
M - Pin type
S - Screw type

Coil Voltage

00 - No coil, nut included (p/n 02-148332)
12D - 12VDC
24D - 24VDC
*Use EPV series, 16W coils

Seal Option

Code	Seal Kit
N - Buna - N (standard)	02-154069
V - Viton	1203263
NF - Buna - N and 60 mesh filter screen	
VF - Viton and 60 mesh filter screen	

Proportional Valves

CP518-PNC

Proportional Flow Control Valve, Spool Type, Normally Closed, Direct Acting, Non-Compensated

210 bar [3000 psi] • 12 l/min [3.2 US gpm]

DESCRIPTION AND OPERATION

This is a 2-way, spool type, normally closed, non-compensated proportional flow control valve. In the de-energized condition, flow is blocked in both directions. Energizing the coil will proportionally open port 2 to 1. Used in conjunction with a compensator, the valve will act as the control orifice for a pressure compensated flow regulator.

SCHEMATIC

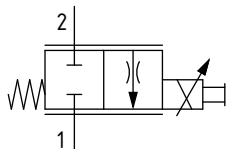

DIMENSIONS

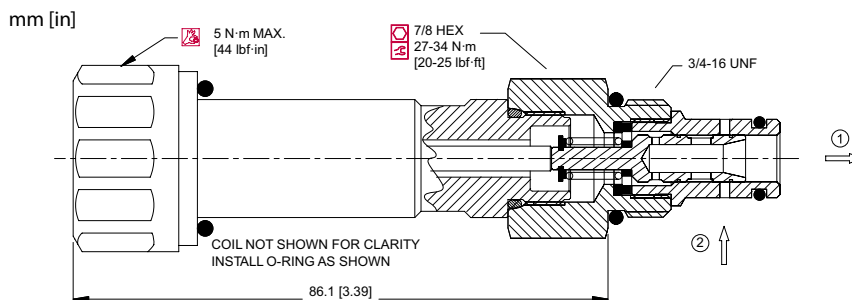

PERFORMANCE DATA

Rated pressure	210 bar [3000 psi]
Rated flow @ 5.5 bar [80 psi]	12 l/min [3.2 US gpm]
Maximum Hysteresis	10%
Threshold current	0.8 A [12 VDC coil] 0.4 A [24 VDC coil]
Maximum control current	1.8 A [12 VDC coil] 0.9 A [24 VDC coil]
Coil Options	M19P
Weight	0.36 kg [0.80 lb]
Cavity	SDC08-2

PERFORMANCE CURVES

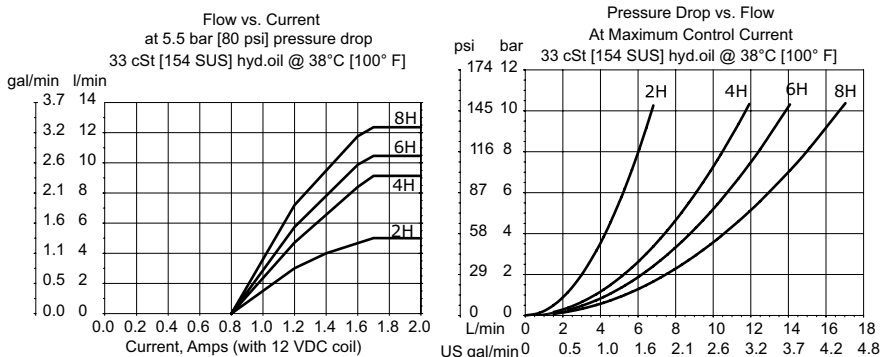

MODEL CODE

CP518 - PNC - U - 6S - 2H - 24D - DE

Seal Option

Code	Seal kit
U - Urethane	120591

Housing

Code	Ports & Material	Housing Model Code
00	No Housing	
4S	AL, #4 SAE	CP08-2-4S
6S	AL, #6 SAE	CP08-2-6S
2B	AL, 1/4 BSP	SDC08-2-DG2B
3B	AL, 3/8 BSP	SDC08-2-DG3B

* Aluminum bodies are to be used for pressures less than 210 bar [3000 psi].

* Additional housings available

Connector Type

00 - No coil
DE - Deutsch
DN - DIN 43650
FL - Lead wires
AJ - AMP Jr

Coil Voltage

00 - No coil, nut included*
12D - 12 VDC
24D - 24 VDC

*Standard Coil - Plastic coil nut and o-rings (p/n 173802188)

Rated Flow at 5.5 bar [80 psi]

Code	Flow
2H	5 l/min [1.3 US gpm]
4H	9 l/min [2.4 US gpm]
6H	10.5 l/min [2.8 US gpm]
8H	12 l/min [3.2 US gpm]

Proportional Valves

PSV10-NC

Proportional Flow Control Valve, Spool Type, Normally Closed, Direct Acting, Non-Compensated

260 bar [3800 psi] • 40 l/min [10.6 US gpm]

DESCRIPTION AND OPERATION

This is a 2-way, spool type, normally closed, non-compensated proportional flow control valve. In the de-energized condition, flow is blocked in both directions. Energizing the coil will proportionally open port 1 to 2. Used in conjunction with a compensator, the valve will act as the control orifice for a pressure compensated flow regulator.

SCHEMATIC

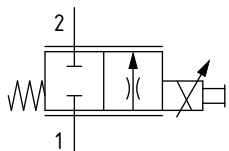

DIMENSIONS

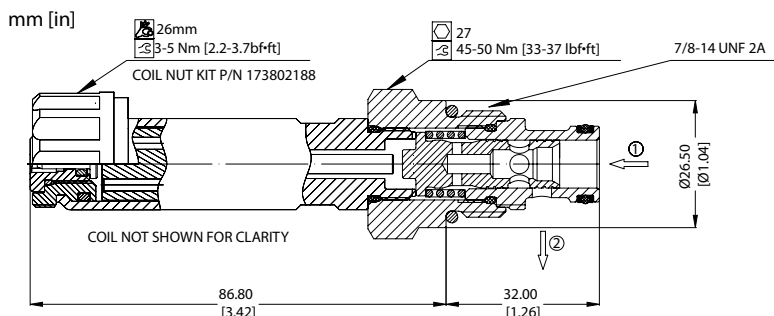

PERFORMANCE DATA

Rated pressure*	260 bar [3800 psi]
Rated flow @ 10 bar [145 psi]	40 l/min [10.6 US gpm]
Leakage	420 ml/min [25.6 in ³ /min] @ rated pressure
Maximum Hysteresis	5%
Threshold current	0.5 A [12 VDC coil] 0.25 A [24 VDC coil]
Maximum control current	1.8 A [12 VDC coil] 0.9 A [24 VDC coil]
Coil Options	M19P
Weight	0.51 kg [1.12 lb]
Cavity	SDC10-2

*Rated pressure based on NFPA fatigue test standards (at 1 million cycles)

PERFORMANCE CURVES

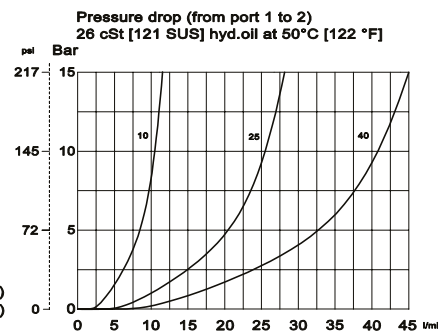
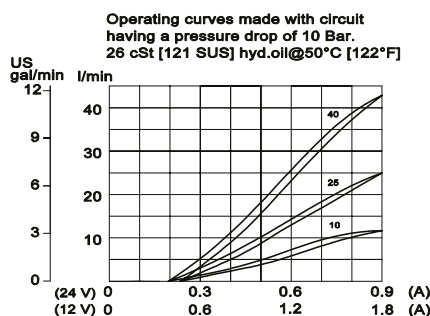

MODEL CODE

PSV10 - NC - 40 - 12D - DE - SPS - B - 6S

Rated Flow @ 10 bar [145 psi]

Code	Flow
10	10 l/min [2.6 US gpm]
25	25 l/min [6.6 US gpm]
40	40 l/min [10.6 US gpm]

Coil Voltage

00 - No coil, nut included*
12D - 12 VDC
24D - 24 VDC

*Standard Coil - Plastic coil nut and o-rings (p/n 173802188)

Connector Type

00 - No coil
AJ - AMP Junior
DE - Deutsch
DN - DIN 43650

Manual Override Option

Omit - Push pin
SPS - Screw Type

Housing

Code	Ports & Material	Housing Model Code
00	No Housing	
6S	AL, #6 SAE	CP10-2-6S
8S	AL, #8 SAE	CP10-2-8S
DG3B	AL, 3/8 BSP	SDC10-2-DG3B
DG4B	AL, 1/2 BSP	SDC10-2-DG4B

* Aluminum bodies are to be used for pressures less than 210 bar [3000 psi].

* Additional housings available

Seal Option

Code	Seal kit
B - Buna - N	354004019
V - Viton	354003419

Proportional Valves

PSV12-NC

Proportional Flow Control Valve, Spool Type, Normally Closed, Direct Acting, Non-Compensated

260 bar [3800 psi] • 80 l/min [21 US gpm]

DESCRIPTION AND OPERATION

This is a 2-way, spool type, normally closed, non-compensated proportional flow control valve. In the de-energized condition, flow is blocked in both directions. Energizing the coil will proportionally open port 1 to 2. Used in conjunction with a compensator, the valve will act as the control orifice for a pressure compensated flow regulator.

SCHEMATIC

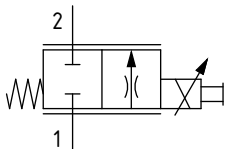

DIMENSIONS

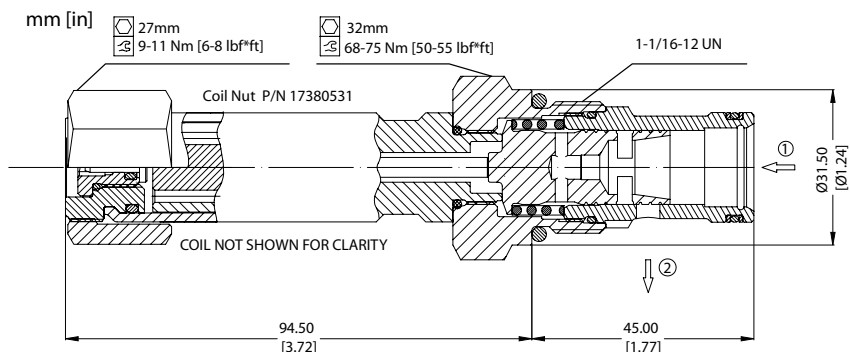

PERFORMANCE DATA

Rated pressure*	260 bar [3800 psi]
Rated flow @ 10 bar [145 psi]	80 l/min [21 US gpm]
Leakage	420 ml/min [25.6 in ³ /min] @rated pressure
Maximum Hysteresis	5%
Threshold current	0.5 A [12 VDC coil] 0.25 A [24 VDC coil]
Maximum control current	1.8 A [12 VDC coil] 0.9 A [24 VDC coil]
Coil Options	D14E [35 Watt]
Weight	0.76 kg [1.68 lb]
Cavity	SDC12-2

*Rated pressure based on NFPA fatigue test standards (at 1 million cycles)

PERFORMANCE CURVES

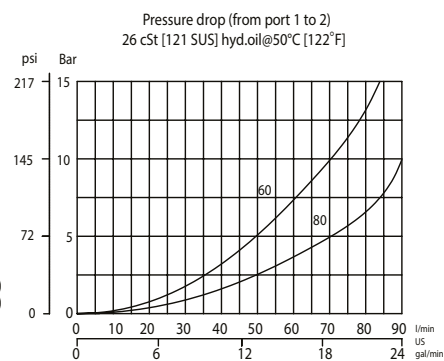
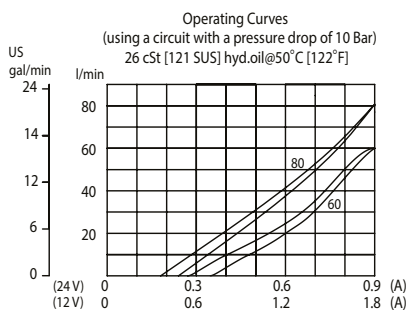

MODEL CODE

PSV12 - NC - 80 - 12D - DE - SPS - B - 00

Rated Flow @ 10 bar [145 psi]

Code	Flow
60	60 l/min [16 US gpm]
80	80 l/min [21 US gpm]

Coil Voltage

00 - No coil, nut included
12D - 12 VDC
24D - 24 VDC

*Aluminum coil nut (p/n 17380531)

Connector Type

00 - No coil
AJ - AMP Junior
DE - Deutsch
DN - DIN 43650

Manual Override Option

Omit - Push Pin
SPS - Screw Type

Housing

Code	Ports & Material	Housing Model Code
00	No Housing	
10S	AL, #10 SAE	CP12-2-10S
12S	AL, #12 SAE	CP12-2-12S
DG4B	AL, 1/2 BSP	SDC12-2-DG4B
DG6B	AL, 3/4 BSP	SDC12-2-DG6B

* Aluminum bodies are to be used for pressures less than 210 bar [3000 psi].
* Additional housings available

Seal Option

Code	Seal kit
B - Buna - N	354008319
V - Viton	354008419

Proportional Valves

PSV16-NC

Proportional Flow Control Valve, Spool Type, Normally Closed, Direct Acting, Non-Compensated

260 bar [3800 psi] • 100 l/min [26 US gpm]

DESCRIPTION AND OPERATION

This is a 2-way, spool type, normally closed, non-compensated proportional flow control valve. In the de-energized condition, flow is blocked in both directions. Energizing the coil will proportionally open port 1 to 2. Used in conjunction with a compensator, the valve will act as the control orifice for a pressure compensated flow regulator.

SCHEMATIC

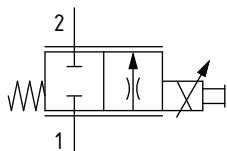

DIMENSIONS

mm [in]

⌀ 27mm
9-11 Nm [6-8 lbf·ft]

⌀ 38mm
122-136 Nm [90-100 lbf·ft]

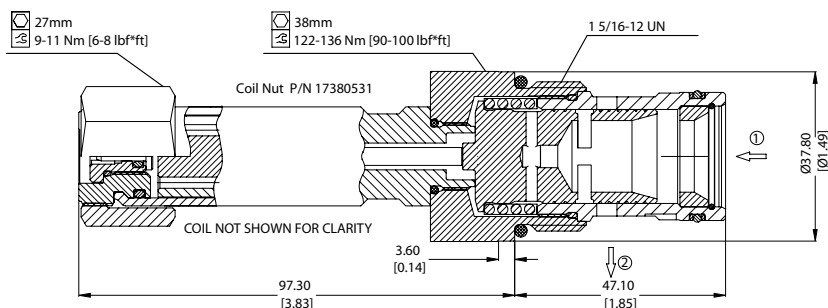

PERFORMANCE DATA

Rated pressure*	260 bar [3800 psi]
Rated flow @ 10 bar [145 psi]	100 l/min [26 US gpm]
Leakage	420 ml/min [25.6 in ³ /min] @ rated pressure
Maximum Hysteresis	5%
Threshold current	0.5 A [12 VDC coil] 0.25 A [24 VDC coil]
Maximum control current	1.8 A [12 VDC coil] 0.9 A [24 VDC coil]
Coil Options	D14E [35 Watt]
Weight	0.87 kg [1.92 lb]
Cavity	SDC16-2

*Rated pressure based on NFPA fatigue test standards (at 1 million cycles)

PERFORMANCE CURVES

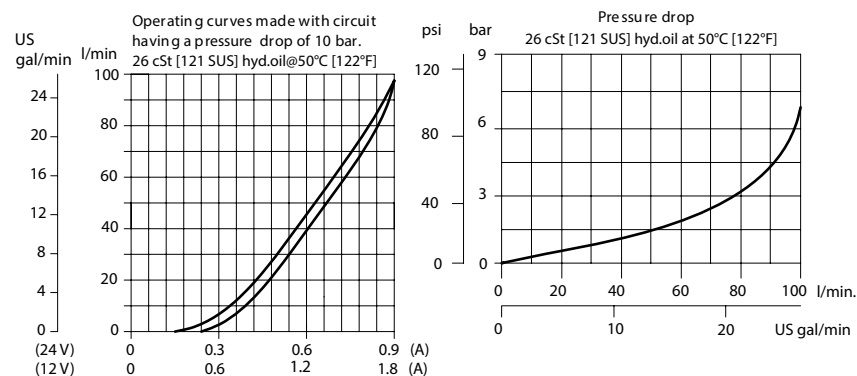

MODEL CODE

PSV16 - NC - 100 - 12D - DN - SPS - B - 12S

Rated Flow at 10 bar [145 psi]

Code	Flow
100	100 l/min [26 US gpm]

Coil Voltage

00 - No coil, nut included
12D - 12 VDC
24D - 24 VDC

*Aluminum coil nut (p/n 17380531)

Connector Type

00 - No coil
AJ - AMP Junior
DE - Deutsch
DN - DIN 43650

Manual Override Option

Omit - Push Pin
SPS - Screw Type

Housing

Code	Ports & Material	Housing Model Code
00	No Housing	
DG6B	AL, 3/4 BSP	SDC16-2-DG-6B
DG8B	AL, #1 BSP	SDC16-2-DG-8B
12S	AL, #12 SAE	CP16-2-12S
16S	AL, #16 SAE	CP16-2-16S

* Aluminum bodies are to be used for pressures less than 210 bar [3000 psi].

* Additional housings available

Seal Option

Code	Seal kit
B - Buna - N	354008719
V - Viton	354008819

Proportional Valves

CP518-PNO

Proportional Flow Control Valve, Spool Type, Normally Open, Direct Acting, Non-Compensated

210 bar [3000 psi] • 11.5 l/min [3 US gpm]

DESCRIPTION AND OPERATION

This is a 2-way, spool type, normally open, non-compensated proportional flow control valve. In the de-energized condition, flow can pass in either direction. Energizing the coil will proportionally close port 2 to 1. Used in conjunction with a compensator, the valve will act as the control orifice for a pressure compensated flow regulator.

SCHEMATIC

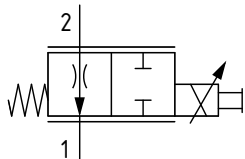

DIMENSIONS

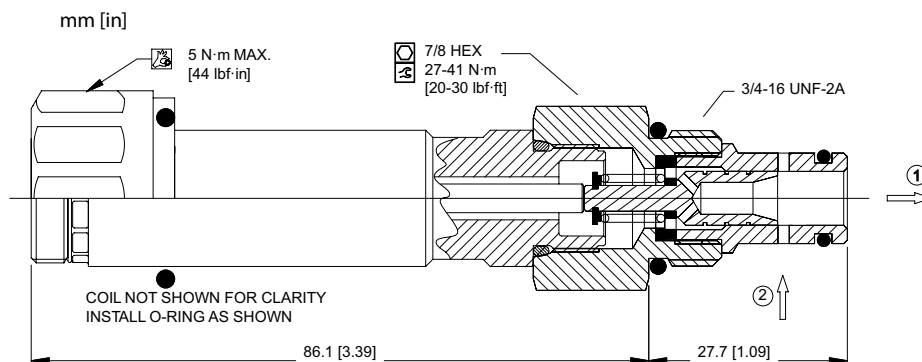

PERFORMANCE DATA

Rated pressure	210 bar [3000 psi]
Rated flow @5.5 bar [80 psi]	11.5 l/min [3 US gpm]
Maximum Hysteresis	4%
Threshold current	0.2 A [12 VDC coil] 0.1 A [24 VDC coil]
Maximum control current	1.2 A [12 VDC coil] 0.6 A [24 VDC coil]
Coil Options	M19P
Weight	0.36 kg [0.80 lb]
Cavity	SDC08-2

PERFORMANCE CURVES

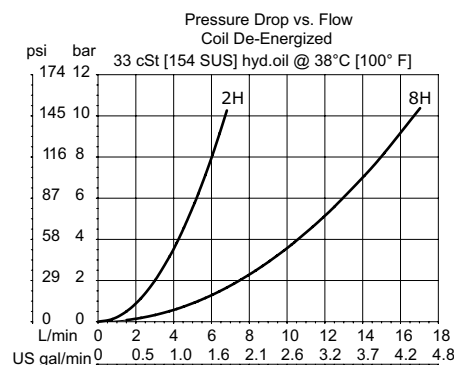
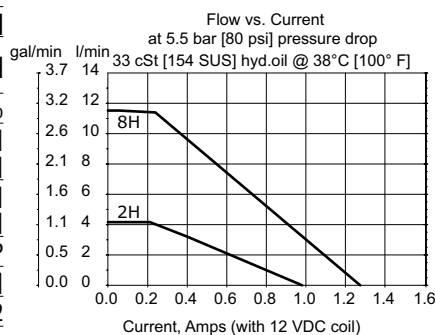

MODEL CODE

CP518 - PNO - U - 6S - 2H - 24D - DE

Seal Option

Code	Seal kit
U - Urethane	120591

Housing

Code	Ports & Material	Housing Model Code
00	No Housing	
4S	AL, #4 SAE	CP08-2-4S
6S	AL, #6 SAE	CP08-2-6S
2B	AL, 1/4 BSP	SDC08-2-DG2B
3B	AL, 3/8 BSP	SDC08-2-DG3B

* Aluminum bodies are to be used for pressures less than 210 bar [3000 psi].

* Additional housings available

Rated Flow at 5.5 bar [80 psi]

Code	Flow
2H	4 l/min [1 US gpm]
8H	11.5 l/min [3 US gpm]

Connector Type

00 - No coil
DE - Deutsch
DN - DIN 43650
FL - Lead wires
AJ - AMP Jr

Coil Voltage

00 - No coil, nut included*
12D - 12 VDC
24D - 24 VDC

*Standard Coil - Plastic coil nut and o-rings (p/n 173802188)

Proportional Valves

PSV10-NO

Proportional Flow Control Valve, Spool Type, Normally Open, Direct Acting, Non-Compensated

260 bar [3800 psi] • 45 l/min [12 US gpm]

DESCRIPTION AND OPERATION

This is a 2-way, spool type, normally open, non-compensated proportional flow control valve. In the de-energized condition, flow can pass in either direction. Energizing the coil will proportionally close port 1 to 2. Used in conjunction with a compensator, the valve will act as the control orifice for a pressure compensated flow regulator.

SCHEMATIC

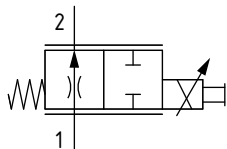

DIMENSIONS

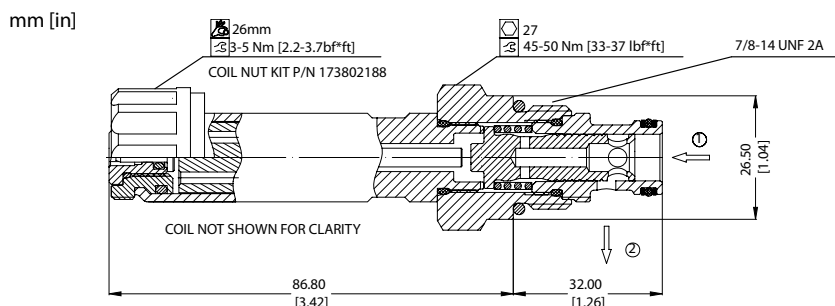

PERFORMANCE DATA

Rated pressure*	260 bar [3800 psi]
Rated flow @ 10 bar [145 psi]	45 l/min [12 US gpm]
Leakage	420 ml/min [25.6 in ³ /min] @ rated pressure
Maximum Hysteresis	5%
Threshold current	0.1 A [12 VDC coil] 0.05 A [24 VDC coil]
Maximum control current	1.8 A [12 VDC coil] 0.9 A [24 VDC coil]
Coil Options	M19P
Weight	0.51 kg [1.12 lb]
Cavity	SDC10-2

*Rated pressure based on NFPA fatigue test standards (at 1 million cycles)

PERFORMANCE CURVES

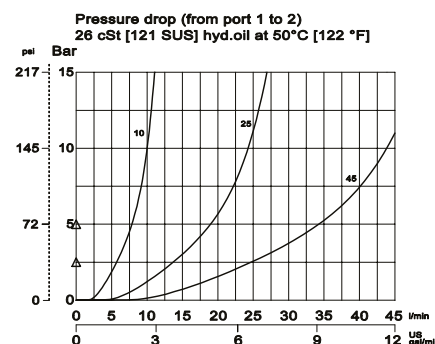
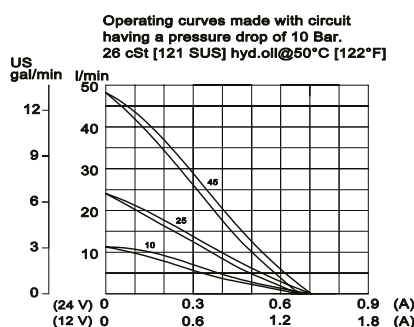

MODEL CODE

PSV10 - NO - 45 - 12D - DE - SPS - B - 6S

Rated Flow at 10 bar [145 psi]

Code	Flow
10	10 l/min [2.6 US gpm]
25	25 l/min [6.6 US gpm]
45	45 l/min [12 US gpm]

Coil Voltage

00 - No coil, nut included*
12D - 12 VDC
24D - 24 VDC

*Standard Coil - Plastic coil nut and o-rings (p/n 173802188)

Connector Type

00 - No coil
AJ - AMP Junior
DE - Deutsch
DN - DIN 43650

Manual Override Option

Omit - Push Pin
SPS - Screw type

Housing

Code	Ports & Material	Housing Model Code
Omit	No housing	
6S	AL, #6 SAE	CP10-2-6S
8S	AL, #8 SAE	CP10-2-8S
DG3B	AL, 3/8 BSP	SDC10-2-DG3B
DG4B	AL, 1/2 BSP	SDC10-2-DG4B

* Aluminum bodies are to be used for pressures less than 210 bar [3000 psi].

* Additional housings available

Seal Option

Code	Seal kit
B - Buna - N	354000401
V - Viton	354000341

Proportional Valves

PSV12-NO

Proportional Flow Control Valve, Spool Type, Normally Open, Direct Acting, Non-Compensated

260 bar [3800 psi] • 100 l/min [26 US gpm]

DESCRIPTION AND OPERATION

This is a 2-way, spool type, normally open, non-compensated proportional flow control valve. In the de-energized condition, flow can pass in either direction. Energizing the coil will proportionally close port 1 to 2. Used in conjunction with a compensator, the valve will act as the control orifice for a pressure compensated flow regulator.

SCHEMATIC

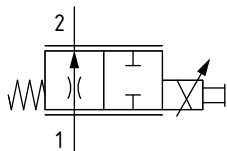

DIMENSIONS

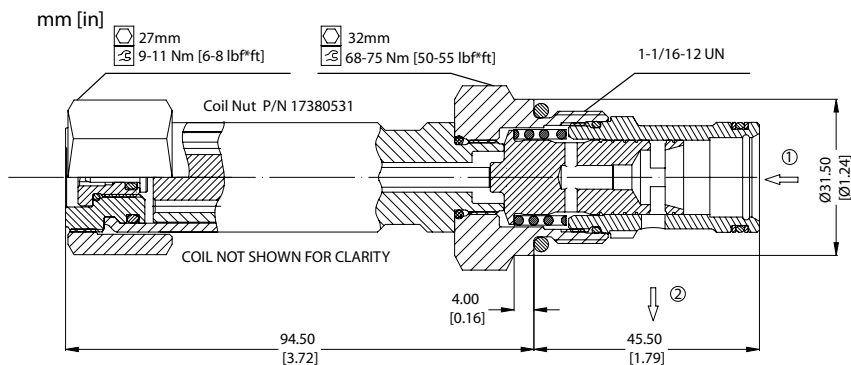

PERFORMANCE DATA

Rated pressure*	260 bar [3800 psi]
Rated flow @10 bar [145 psi]	100 l/min [26 US gpm]
Leakage	420 ml/min [25.6 in ³ /min] @rated pressure
Maximum Hysteresis	5%
Threshold current	0.3 A [12 VDC coil] 0.15 A [24 VDC coil]
Maximum control current	1.8 A [12 VDC coil] 0.9 A [24 VDC coil]
Coil Options	D14E [35 Watt]
Weight	0.76 kg [1.68 lb]
Cavity	SDC12-2

*Rated pressure based on NFPA fatigue test standards (at 1 million cycles)

PERFORMANCE CURVES

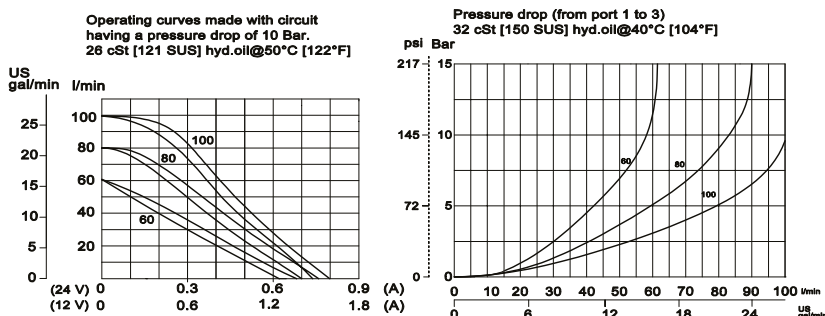

MODEL CODE

PSV12 - NO - 100 - 12D - DE - SPS - B - 10S

Rated flow at 10 bar [145 psi]

Code	Flow
60	60 l/min [16 US gpm]
80	80 l/min [21 US gpm]
100	100 l/min [26 US gpm]

Coil Voltage

00 - No coil, nut included
12D - 12 VDC
24D - 24 VDC

*Aluminum coil nut (p/n 17380531)

Connector Type

00 - No coil
AJ - AMP Junior
DE - Deutsch
DN - DIN 43650

Manual Override Option

Omit - Push Pin
SPS - Screw Type

Housing

Code	Ports & Material	Housing Model Code
Omit	No housing	
10S	AL, #10 SAE	CP12-2-10S
12S	AL, #12 SAE	CP12-2-12S
DG4B	AL, 1/2 BSP	SDC12-2-DG4B
DG6B	AL, 3/8 BSP	SDC12-2-DG6B

* Aluminum bodies are to be used for pressures less than 210 bar [3000 psi].

* Additional housings available

Seal Option

Code	Seal kit
B - Buna - N	354008319
V - Viton	354008419

Proportional Valves

PSV16-NO

Proportional Flow Control Valve, Spool Type, Normally Open, Direct Acting, Non-Compensated

260 bar [3800 psi] • 110 l/min [29 US gpm]

DESCRIPTION AND OPERATION

This is a 2-way, spool type, normally open, non-compensated proportional flow control valve. In the de-energized condition, flow can pass in either direction. Energizing the coil will proportionally close port 1 to 2. Used in conjunction with a compensator, the valve will act as the control orifice for a pressure compensated flow regulator.

SCHEMATIC

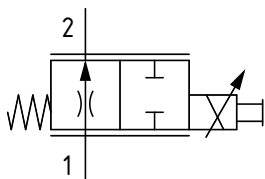

DIMENSIONS

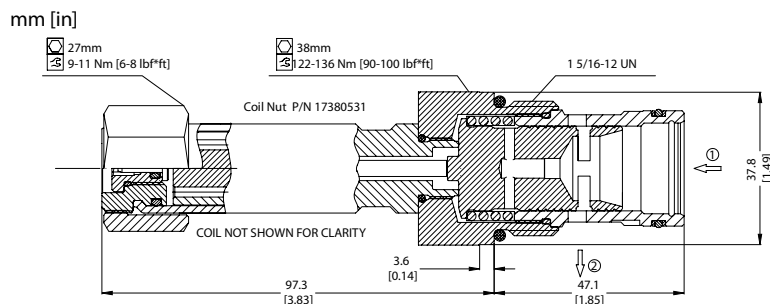

PERFORMANCE DATA

Rated pressure*	260 bar [3800 psi]
Rated flow @10 bar [145 psi]	110 l/min [29 US gpm]
Leakage	420 ml/min [25.6 in ³ /min] @ Rated pressure
Maximum Hysteresis	5%
Threshold current	0.3 A [12 VDC coil] 0.15 A [24 VDC coil]
Maximum control current	1.8 A [12 VDC coil] 0.9 A [24 VDC coil]
Coil Options	D14E [35W]
Weight	0.87 kg [1.92 lb]
Cavity	SDC16-2

*Rated pressure based on NFPA fatigue test standards (at 1 million cycles)

PERFORMANCE CURVES

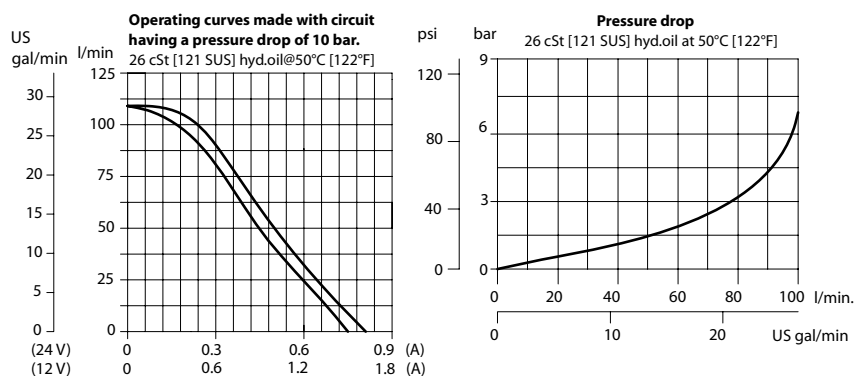

MODEL CODE

PSV16- NO - 110 - 12D - DE - SPS - B - 12S

Rated flow at 10 bar [145 psi]

Code	Flow
110	110 l/min [29 US gpm]

Coil Voltage

00 - No coil, nut included
12D - 12 VDC
24D - 24 VDC

*Aluminum coil nut (p/n 17380531)

Connector Type

00 - No coil
AJ - AMP Junior
DE - Deutsch
DN - DIN 43650

Manual Override Option

Omit - Push Pin
SPS - Screw Type

Housing

Code	Ports & Material	Housing Model Code
00	No housing	
DG6B	AL, 3/4 BSP	SDC16-2-DG-6B
DG8B	AL, 1 BSP	SDC16-2-DG-8B
12S	AL, #12 SAE	CP16-2-12S
16S	AL, #16 SAE	CP16-2-16S

* Aluminum bodies are to be used for pressures less than 210 bar [3000 psi].

* Additional housings available

Seal Option

Code	Seal kit
B - Buna - N	354008719
V - Viton	354008819

Proportional Valves

PFR24A

Proportional Flow Control Valve, Spool Type, Normally Closed, Direct Acting, Pressure Compensated

210 bar [3000 psi] • 28 l/min [7.4 US gpm]

DESCRIPTION AND OPERATION

This is a 2-way, spool type, normally closed, pressure compensated proportional flow control valve. In the de-energized condition, the valve is closed in both directions. Energizing the coil will open the valve proportionally between port 2 and port 1, controlling the flow regardless of changes in differential pressure. The valve also provides some compensation when flow takes place from port 1 to 2.

SCHEMATIC

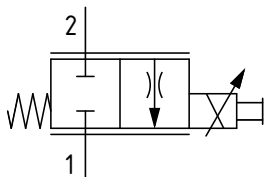

PERFORMANCE DATA

Rated pressure	210 bar [3000 psi]
Max Regulated Flow	28 l/min [7.4 US gpm]
Leakage	200 ml/min@ 210 bar [3000 psi]
Maximum Hysteresis	4%
Recommended PWM frequency	200 Hz
Threshold current	25-30% of rated current
Coil Options	C16
Weight	0.2 kg [0.44 lb]
Cavity	A6701

DIMENSIONS

mm [in]

Coil Not Torque
3.4 Nm [2.5 ft lbs]

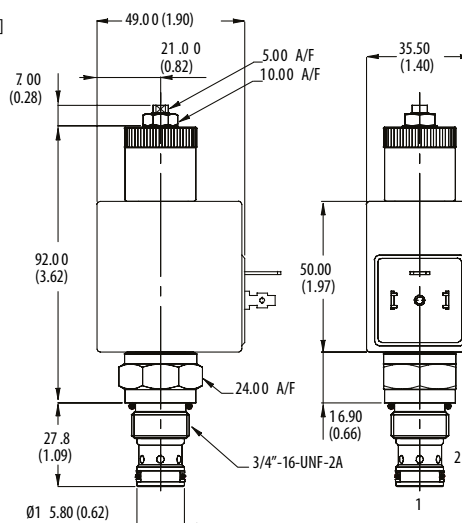

Installation torque
A - 30 Nm (22 lbs ft)

PERFORMANCE CURVES

Pressure drop curves

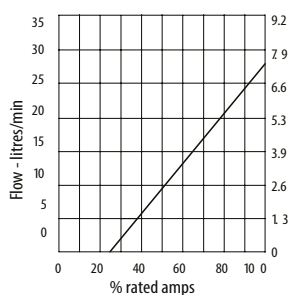
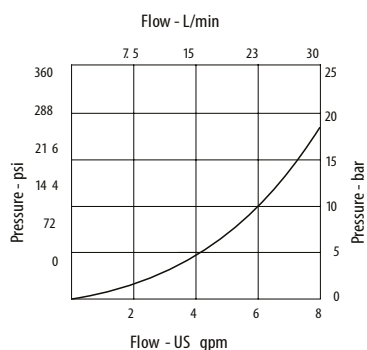

Pressure differential - bar

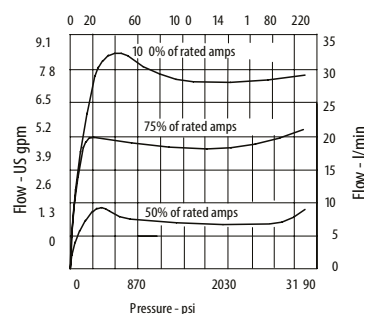

MODEL CODE

PFR24A - N - 6 - H - 24 - 3W

Seal Option

Code	Seal kit	Manual Override Option
N - Nitrile	SK1138	6 - Screw Type
V - Viton	SK1138V	

Connector Type

Omit	No coil
H	DIN 43650
F	Flying Lead
DM	Deutsch moulded

Coil Voltage

Omit	No coil
12	12 VDC
24	24 VDC

Housing

Code	Ports	Aluminium
Omit		No housing
2W	1/4" BSP	A12592
3W	3/8" BSP	A7450
6T	3/8" SAE	A19355

* Aluminum bodies are to be used for pressures less than 210 bar [3000 psi].

* Additional housings available

Proportional Valves

PFR21H

Proportional Flow Control Valve, Poppet Type, Normally Closed, Direct Acting, Partially Compensated
210 bar [3000 psi] • 20 l/min [5.3 US gpm]

DESCRIPTION AND OPERATION

This is a 2-way, poppet type, normally closed, partially pressure compensated proportional flow control valve. In the de-energized condition, flow is blocked in both directions. Energizing the coil will proportionally push the poppet away from its seat, opening port 2 to 1. This valve is ideal as a lowering valve for single acting cylinders.

SCHEMATIC

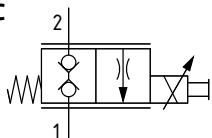

PERFORMANCE DATA

Rated pressure	210 bar [3000 psi]
Max regulated flow	20 l/min [5.3 US gpm]
Leakage	10 drops/min @ 210 bar [3000 psi]
Recommended PWM frequency	200 Hz
Threshold current	38-60% of rated current
Coil Options	C16
Weight	0.2 kg [0.44 lb]
Cavity	A6701

DIMENSIONS

mm [in]

Coil Nut Torque
3.4 Nm [2.5 ft. lbs]

Installation torque
A - 30 Nm [22 ft. lbs]

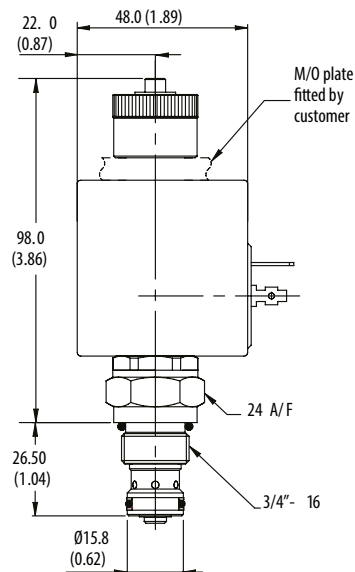

PERFORMANCE CURVES

Pressure drop

Viscosity = 32 cSt (150 SSU)

PFR21H @ 100%

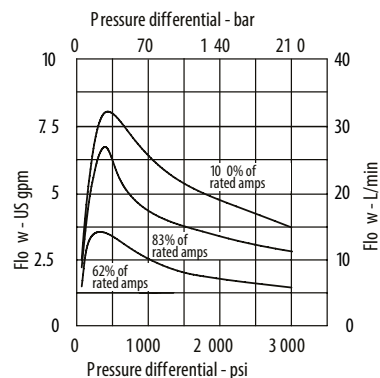
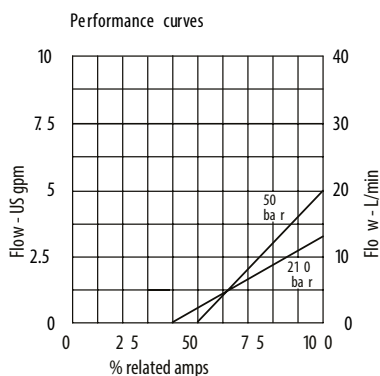
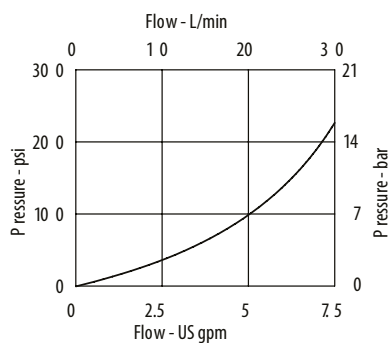

MODEL CODE

PFR21H - N - 6 - H - 24 - 3W

Seal Option

Code	Seal kit
N - Nitrile	SK1138
V - Viton	SK1138V

Manual Override Option

6 - Screw

Connector Type

Omit - No Coil
H - DIN 43650
F - Flying Lead
DM - Deutsch moulded

Coil Voltage

Omit - No Coil
12 - 12 VDC
24 - 24 VDC

Housing

Code	Ports	Aluminum
Omit	No housing	
2W	1/4" BSP	A12592
3W	3/8" BSP	A7450
6T	3/8" SAE	A19355

* Aluminum bodies are to be used for pressures less than 210 bar [3000 psi].
* Additional housings available

Proportional Valves

PFC10-RC

Proportional Flow Control Valve, Normally Closed, Restrictive Type, Pressure Compensated

260 bar [3800 psi] • 30 l/min [8 US gpm]

DESCRIPTION AND OPERATION

This is a 2-way, spool type, normally closed, restrictive type, pressure compensated proportional flow control valve. In the de-energized condition, flow is blocked in both directions. Energizing the coil will proportionally move the spool, opening a variable orifice from port 1 to 2. An internal compensating spool ensures that the output flow at port 2 remains constant, regardless of changes in differential pressure. Increasing the current to the coil will increase the outlet flow.

SCHEMATIC

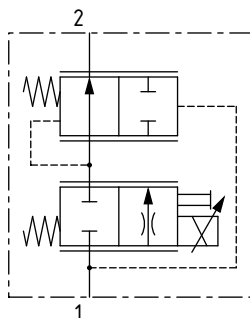

DIMENSIONS

mm [in]

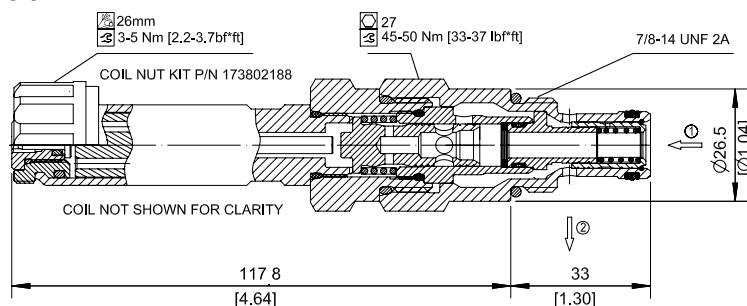

PERFORMANCE DATA

Rated pressure*	260 bar [3800 psi]
Max regulated flow	30 l/min [8 US gpm]
Leakage	420 ml/min [25.6 in ³ /min] @rated pressure
Maximum Hysteresis	8%
Threshold current	0.5 A [12 VDC coil] 0.25 A [24 VDC coil]
Maximum control current	1.8 A [12 VDC coil] 0.9 A [24 VDC coil]
Coil Options	M19P
Weight	0.65 kg [1.43 lb]
Cavity	SDC10-2

*Rated pressure based on NFPA fatigue test standards (at 1 million cycles)

PERFORMANCE CURVES

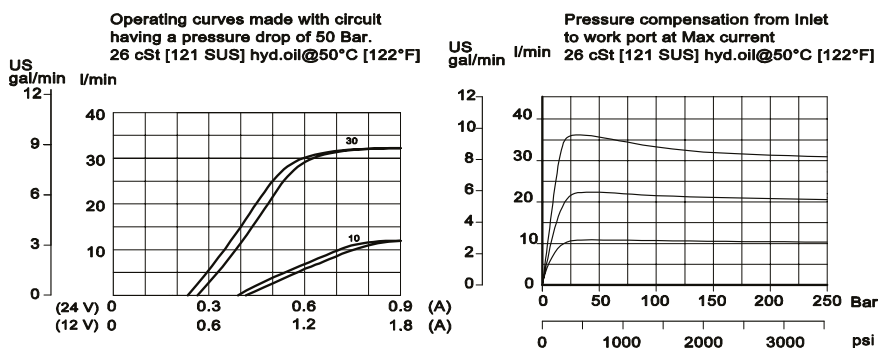

MODEL CODE

PFC10-RC-30-12D-DE-SPS-B-6S

Max Regulated Flow

Code	Flow
10	10 l/min [2.6 US gpm]
30	30 l/min [8 US gpm]

Coil Voltage

00 - No coil, nut included*
12D - 12 VDC
24D - 24 VDC

*Standard Coil - Plastic coil nut and o-rings (p/n 173802188)

Connector Type

00 - No coil
AJ - AMP Junior
DE - Deutsch
DN - DIN 43650

Manual Override Option

Omit - Push Pin
SPS - Screw Type

Housing

Code	Ports & Material	Housing Model Code
00	No housing	
6S	AL, #6 SAE	CP10-2-6S
8S	AL, #8 SAE	CP16-2-8S
DG3B	AL, 3/8 BSP	SDC10-2-DG3B
DG4B	AL, 1/2 BSP	SDC10-2-DG4B

* Aluminum bodies are to be used for pressures less than 210 bar [3000 psi].

* Additional housings available

Seal Option

Code	Seal kit
B - Buna - N	35400401
V - Viton	35400341

Proportional Valves

PFC12-RC

Proportional Flow Control Valve, Normally Closed, Restrictive Type, Pressure Compensated

260 bar [3800 psi] • 65 l/min [17 US gpm]

DESCRIPTION AND OPERATION

This is a 2-way, spool type, normally closed, restrictive type, pressure compensated proportional flow control valve. In the de-energized condition, flow is blocked in both directions. Energizing the coil will proportionally move the spool, opening a variable orifice from port 1 to 2. An internal compensating spool ensures that the output flow at port 2 remains constant, regardless of changes in differential pressure. Increasing the current to the coil will increase the outlet flow.

SCHEMATIC

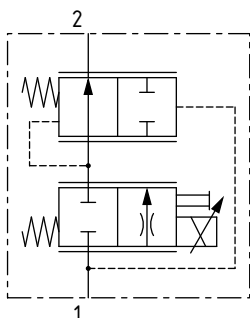

DIMENSIONS

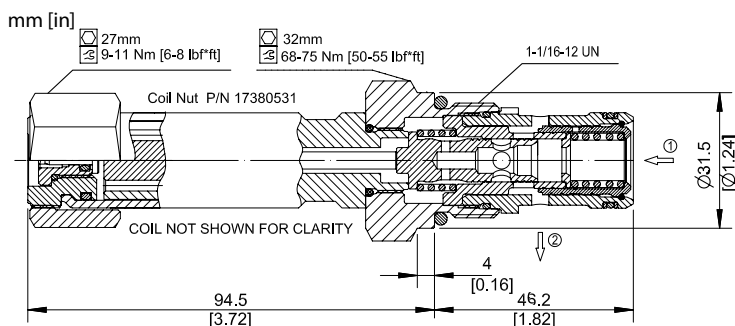

PERFORMANCE DATA

Rated pressure*	260 bar [3800 psi]
Max Regulated Flow	65 l/min [17 US gpm]
Leakage	420 ml/min [25.6 in ³ /min] @rated pressure
Maximum Hysteresis	8%
Threshold current	0.5 A [12VDC coil] 0.25 A [24VDC coil]
Maximum control current	1.8 A [12 VDC coil] 0.9 A [24 VDC coil]
Coil Options	D14E [35 Watt]
Weight	0.77 kg [1.70 lb]
Cavity	SDC12-2

*Rated pressure based on NFPA fatigue test standards (at 1 million cycles)

PERFORMANCE CURVES

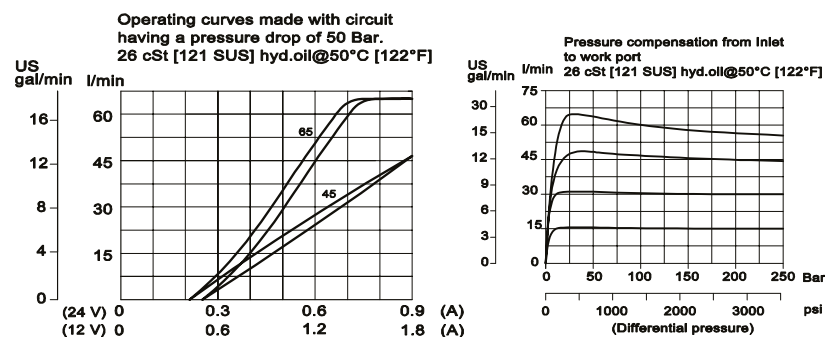

MODEL CODE

PFC12-RC-65-12D-DE-SPS-B-00

Max Regulated Flow

Code	Flow
45	45 l/min [12 US gpm]
65	65 l/min [17 US gpm]

Coil Voltage

00 - No coil, nut included*
12D - 12 VDC
24D - 24 VDC
*Aluminum coil nut (p/n 17380531)

Connector Type

00 - No coil
AJ - AMP Junior
DE - Deutsch
DN - DIN 43650

Manual Override Option

Omit - Push Pin
SPS - Screw Type

Housing

Code	Ports & Material	Housing Model Code
00	No housing	
10S	AL, #10 SAE	CP12-2-10S
12S	AL, #12 SAE	CP12-2-12S
DG4B	AL, 1/2 BSP	SDC12-2-DG4B
DG6B	AL, 3/4 BSP	SDC12-2-DG6B

* Aluminum bodies are to be used for pressures less than 210 bar [3000 psi].
* Additional housings available

Seal Option

Code	Seal kit
B - Buna - N	354008319
V - Viton	354008419

Proportional Valves

PFC16-RC

Proportional Flow Control Valve, Normally Closed, Restrictive Type, Pressure Compensated

260 bar [3800 psi] • 90 l/min [24 US gpm]

DESCRIPTION AND OPERATION

This is a 2-way, spool type, normally closed, restrictive type, pressure compensated proportional flow control valve. In the de-energized condition, flow is blocked in both directions. Energizing the coil will proportionally move the spool, opening a variable orifice from port 1 to 2. An internal compensating spool ensures that the output flow at port 2 remains constant, regardless of changes in differential pressure. Increasing the current to the coil will increase the outlet flow.

SCHEMATIC

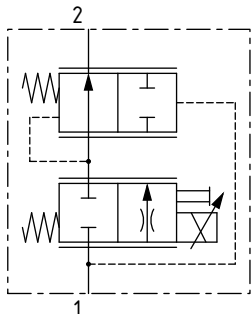

DIMENSIONS

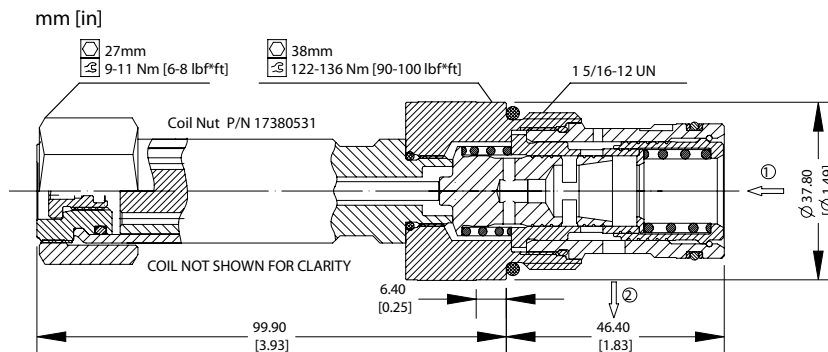

PERFORMANCE DATA

Rated pressure*	260 bar [3800 psi]
Max Regulated Flow	90 l/min [24 US gpm]
Leakage	420 ml/min [25.6 in ³ /min] @rated pressure
Maximum Hysteresis	8%
Threshold current	0.4 A [12 VDC coil] 0.2 A [24 VDC coil]
Maximum control current	1.8 A [12 VDC coil] 0.9 A [24 VDC coil]
Coil Options	D14E [35 Watt]
Weight	0.91 kg [2.01 lb]
Cavity	SDC16-2

*Rated pressure based on NFPA fatigue test standards (at 1 million cycles)

PERFORMANCE CURVES

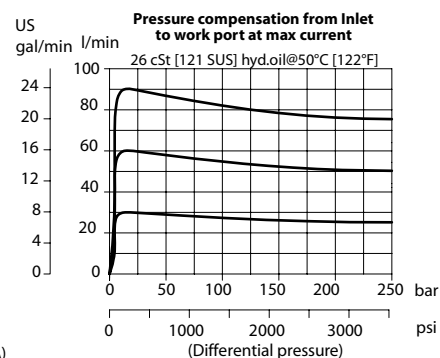
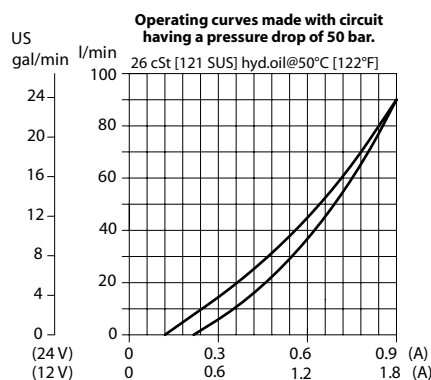

MODEL CODE

PFC16-RC-90-12D-DE-SPS-B-00

Max Regulated Flow

Code	Flow
90	90 l/min [24 US gpm]

Coil Voltage

00 - No coil, nut included*
12D - 12 VDC
24D - 24 VDC
*Aluminum coil nut (p/n 17380531)

Connector Type

00 - No coil
AJ - AMP Junior
DE - Deutsch
DN - DIN 43650

Manual Override Option

Omit - Push Pin
SPS - Screw Type

Housing

Code	Ports & Material	Housing Model Code
00	No housing	
DG6B	AL, 3/4 BSP	SDC16-2-DG-6B
DG8B	AL, 1 BSP	SDC16-2-DG-8B
12S	AL, #12 SAE	CP16-2-12S
16S	AL, #16 SAE	CP16-2-16S

* Aluminum bodies are to be used for pressures less than 210 bar [3000 psi].
* Additional housings available

Seal Option

Code	Seal kit
B - Buna - N	354008719
V - Viton	354008819

Proportional Valves

PFC10-RO

Proportional Flow Control Valve, Normally Open, Restrictive Type, Pressure Compensated

260 bar [3800 psi] • 30 l/min [8 US gpm]

DESCRIPTION AND OPERATION

This is a 2-way, spool type, normally open, restrictive type, pressure compensated proportional flow control valve. In the de-energized condition, maximum flow passes from port 1 to 2. Energizing the coil will proportionally move the spool, restricting flow out of port 2 through a variable orifice. An internal compensating spool ensures that the output flow at port 2 remains constant, regardless of changes in differential pressure. Increasing the current to the coil will increase the outlet flow.

SCHEMATIC

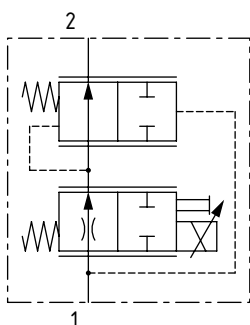

DIMENSIONS

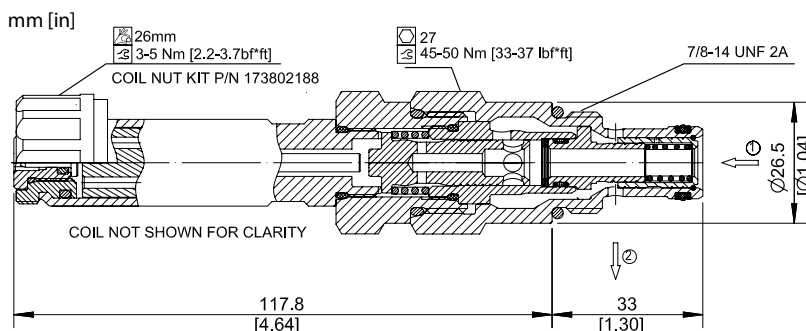

PERFORMANCE DATA

Rated pressure*	260 bar [3800 psi]
Max Regulated Flow	30 l/min [8 US gpm]
Leakage	420 ml/min [25.6 in ³ /min] @rated pressure
Maximum Hysteresis	8%
Threshold current	0.2 A [12 VDC coil] 0.1 A [24 VDC coil]
Maximum control current	1.8 A [12 VDC coil] 0.9 A [24 VDC coil]
Coil Options	M19P
Weight	0.65 kg [1.43 lb]
Cavity	SDC10-2

*Rated pressure based on NFPA fatigue test standards (at 1 million cycles)

PERFORMANCE CURVES

Operating curves made with circuit having a pressure drop of 50 Bar.
32 cSt [150 SUS] hyd.oil@40°C [104°F]

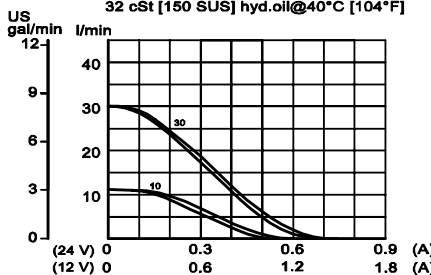

Pressure compensation from Inlet to work port
32 cSt [150 SUS] hyd.oil@40°C [104°F]

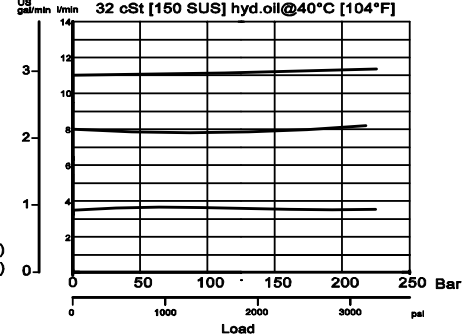

MODEL CODE

PFC10 - RO - 30 - 12D - DE - SPS - B - 00

Max Regulated Flow

Code	Flow
10	10 l/min [2.6 US gpm]
30	30 l/min [8 US gpm]

Coil Voltage

00 - No coil, nut included*
12D - 12 VDC
24D - 24 VDC

*Standard Coil - Plastic coil nut and o-rings (p/n 173802188)

Connector Type

00 - No coil
AJ - AMP Junior
DE - Deutsch
DN - DIN 43650

Manual Override Option

Omit - Push Pin
SPS - Screw Type

Housing

Code	Ports & Material	Housing Model Code
00	No housing	
65	AL, #6 SAE	CP10-2-65
85	AL, #8 SAE	CP10-2-85
DG3B	AL, 3/8 BSP	SDC10-2-DG3B
DG4B	AL, 1/2 BSP	SDC10-2-DG4B

* Aluminum bodies are to be used for pressures less than 210 bar [3000 psi].

* Additional housings available

Seal Option

Code	Seal kit
B - Buna - N	354004019
V - Viton	354003419

Proportional Valves

PFC12-RO

Proportional Flow Control Valve, Normally Open, Restrictive Type, Pressure Compensated

260 bar [3800 psi] • 60 l/min [16 US gpm]

DESCRIPTION AND OPERATION

This is a 2-way, spool type, normally open, restrictive type, pressure compensated proportional flow control valve. In the de-energized condition, maximum flow passes from port 1 to 2. Energizing the coil will proportionally move the spool, restricting flow out of port 2 through a variable orifice. An internal compensating spool ensures that the output flow at port 2 remains constant, regardless of changes in differential pressure. Increasing the current to the coil will increase the outlet flow.

SCHEMATIC

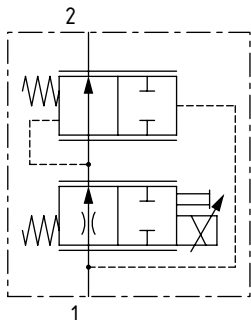

DIMENSIONS

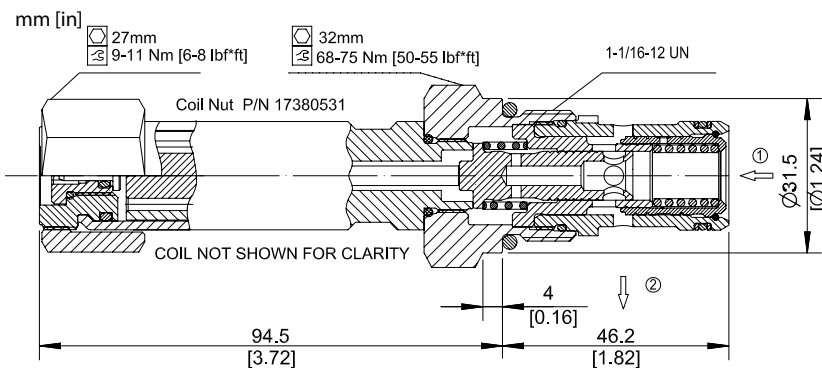

PERFORMANCE DATA

Rated pressure*	260 bar [3800 psi]
Max Regulated Flow	60 l/min [16 US gpm]
Leakage	420 ml/min [25.6 in ³ /min] @Rated pressure
Maximum Hysteresis	8%
Threshold current	0.42 A [12 VDC coil] 0.21 A [24 VDC coil]
Maximum control current	1.8 A [12 VDC coil] 0.9 A [24 VDC coil]
Coil Options	D14E [35 Watt]
Weight	0.77 kg [1.70 lb]
Cavity	SDC12-2

*Rated pressure based on NFPA fatigue test standards (at 1 million cycles)

PERFORMANCE CURVES

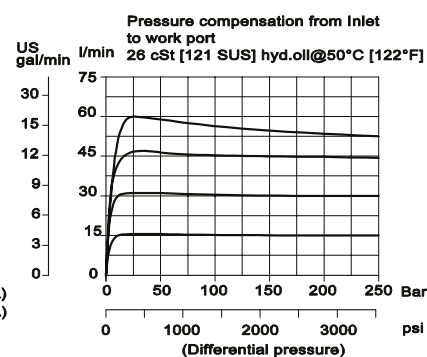
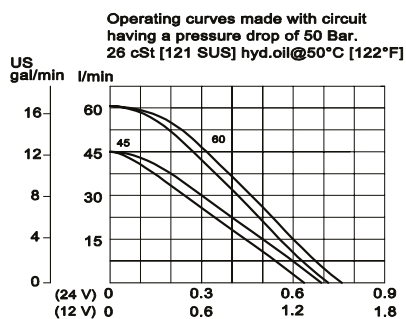

MODEL CODE

PFC12 - RO - 60 - 12D - DE - SPS - B - 00

Max Regulated Flow

Code	Flow
45	45 l/min [12 US gpm]
60	60 l/min [16 US gpm]

Coil Voltage

00 - No coil, nut included*
12D - 12 VDC
24D - 24 VDC

*Aluminum coil nut (p/n 17380531)

Connector Type

00 - No coil
AJ - AMP Junior
DE - Deutsch
DN - DIN 43650

Manual Override Option

Omit - Push Pin
SPS - Screw Type

Housing

Code	Ports & Material	Housing Model Code
00	No housing	
10S	AL, #10 SAE	CP12-2-10S
12S	AL, #12 SAE	CP12-2-12S
DG4B	AL, 1/2 BSP	SDC12-2-DG4B
DG6B	AL, 3/4 BSP	SDC12-2-DG6B

*Aluminum bodies are to be used for pressures less than 210 bar [3000 psi].

*Additional housings available

Seal Option

Code	Seal kit
B - Buna - N	354008319
V - Viton	354008419

Proportional Valves

PFC16-RO

Proportional Flow Control Valve, Normally Open, Restrictive Type, Pressure Compensated

260 bar [3800 psi] • 85 l/min [22.5 US gpm]

DESCRIPTION AND OPERATION

This is a 2-way, spool type, normally open, restrictive type, pressure compensated proportional flow control valve. In the de-energized condition, maximum flow passes from port 1 to 2. Energizing the coil will proportionally move the spool, restricting flow out of port 2 through a variable orifice. An internal compensating spool ensures that the output flow at port 2 remains constant, regardless of changes in differential pressure. Increasing the current to the coil will increase the outlet flow.

SCHEMATIC

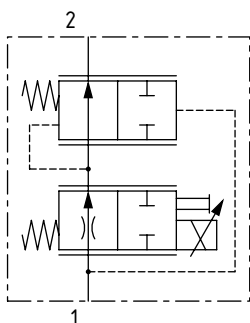

DIMENSIONS

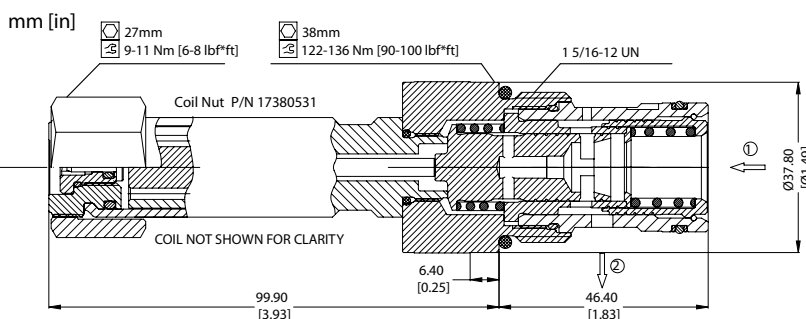

PERFORMANCE DATA

Rated pressure*	260 bar [3800 psi]
Max Regulated Flow	85 l/min [22.5 US gpm]
Leakage	420 ml/min [25.6 in ³ /min] @Rated pressure
Maximum Hysteresis	8%
Threshold current	0.2 A [12 VDC coil] 0.1 A [24 VDC coil]
Maximum control current	1.8 A [12 VDC coil] 0.9 A [24 VDC coil]
Coil Options	D14E [35 Watt]
Weight	0.91 kg [2.01 lb]
Cavity	SDC16-2

*Rated pressure based on NFPA fatigue test standards (at 1 million cycles)

PERFORMANCE CURVES

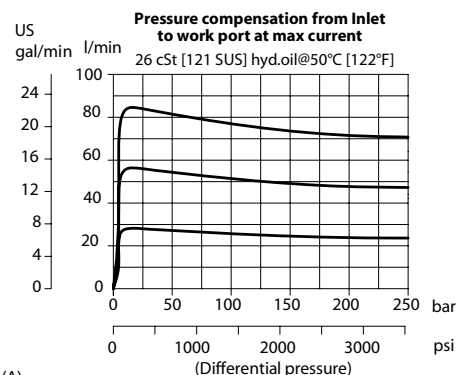
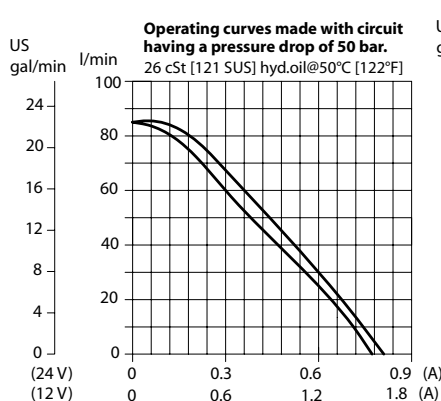

MODEL CODE

PFC16-RO-85-12D-DE-SPS-B-00

Max Regulated Flow

Code	Flow
85	85 l/min [22.5 US gpm]

Coil Voltage

00 - No coil, nut included*
12D - 12 VDC
24D - 24 VDC

*Aluminum coil nut (p/n 17380531)

Connector Type

00 - No coil
AJ - AMP Junior
DE - Deutsch
DN - DIN 43650

Manual Override Option

Omit - Push Pin
SPS - Screw Type

Housing

Code	Ports & Material	Housing Model Code
00	No housing	
DG6B	AL, 3/4 BSP	SDC16-2-DG-6B
DG8B	AL, 1 BSP	SDC16-2-DG-8B
12S	AL, #12 SAE	CP16-2-12S
16S	AL, #16 SAE	CP16-2-16S

*Aluminum bodies are to be used for pressures less than 210 bar [3000 psi].

*Additional housings available

Seal Option

Code	Seal kit
B - Buna - N	354008719
V - Viton	354008819

Proportional Valves

PFC10-PC

Proportional Flow Control Valve, Normally Closed, Priority Type, Pressure Compensated

260 bar [3800 psi] • 40 l/min [10.6 US gpm]

DESCRIPTION AND OPERATION

This is a 3-way, spool type, normally closed, priority type, pressure compensated proportional flow control valve. In the de-energized condition, flow is blocked from port 1 to the priority port 3 and all flow passes from port 1 to 2. Energizing the coil will proportionally move the spool, opening a variable orifice from port 1 to 3, while excess flow passes to port 2. An internal compensating spool ensures that the output flow at port 3 remains constant, regardless of changes in differential pressure between port 1 and 3 or pressure at the bypass port 2. Increasing the current to the coil will increase the priority outlet flow.

SCHEMATIC

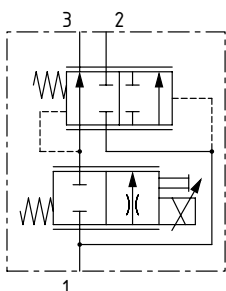

DIMENSIONS

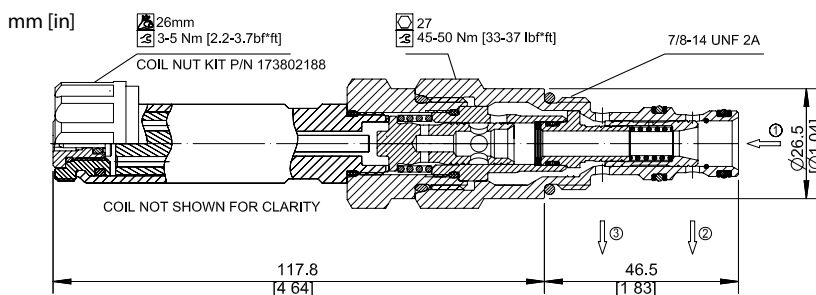

PERFORMANCE DATA

Rated pressure*	260 bar [3800 psi]
Max Regulated Flow	40 l/min [10.6 US gpm]
Leakage	420 ml/min [25.6 in ³ /min] @rated pressure
Maximum Hysteresis	8%
Threshold current	0.36 A [12 VDC coil] 0.18 A [24 VDC coil]
Maximum control current	1.8 A [12 VDC coil] 0.9 A [24 VDC coil]
Coil Options	M19P
Weight	0.62 kg [1.37 lb]
Cavity	SDC10-3

*Rated pressure based on NFPA fatigue test standards (at 1 million cycles)

PERFORMANCE CURVES

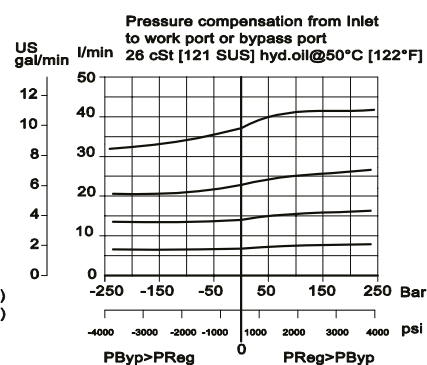
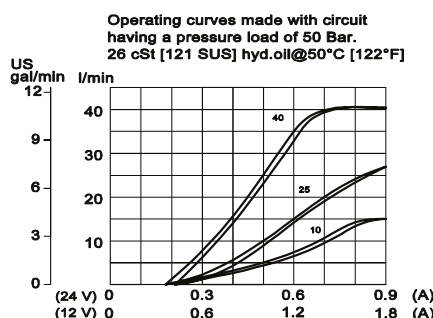

MODEL CODE

PFC10-PC-40-12D-DE-SPS-B-00

Max Regulated Flow

Code	Flow
10	10 l/min [2.6 US gpm]
25	25 l/min [6.6 US gpm]
40	40 l/min [10.6 US gpm]

Coil Voltage

00 - No coil, nut included*
12D - 12 VDC
24D - 24 VDC
*Standard Coil - Plastic coil nut and o-rings (p/n 173802188)

Connector Type

00 - No coil
AJ - AMP Junior
DE - Deutsch
DN - DIN 43650

Manual Override Option

Omit - Push Pin
SPS - Screw Type

Housing

Code	Ports & Material	Housing Model Code
00	No housing	
65	AL, #6 SAE	CP10-3-65
85	AL, #8 SAE	CP10-3-85
SE3B	AL, 3/8 BSP	SDC10-3-SE3B
SE4B	AL, 1/2 BSP	SDC10-3-SE4B

* Aluminum bodies are to be used for pressures less than 210 bar [3000 psi].
* Additional housings available

Seal Option

Code	Seal kit
B - Buna - N	35400421
V - Viton	35400371

Proportional Valves

PFC12-PC

Proportional Flow Control Valve, Normally Closed, Priority Type, Pressure Compensated

260 bar [3800 psi] • 65 l/min [17 US gpm]

DESCRIPTION AND OPERATION

This is a 3-way, spool type, normally closed, priority type, pressure compensated proportional flow control valve. In the de-energized condition, flow is blocked from port 1 to the priority port 3 and all flow passes from port 1 to 2. Energizing the coil will proportionally move the spool, opening a variable orifice from port 1 to 3, while excess flow passes to port 2. An internal compensating spool ensures that the output flow at port 3 remains constant, regardless of changes in differential pressure between port 1 and 3 or pressure at the bypass port 2. Increasing the current to the coil will increase the priority outlet flow.

SCHEMATIC

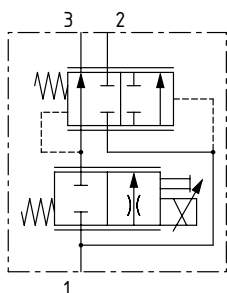

DIMENSIONS

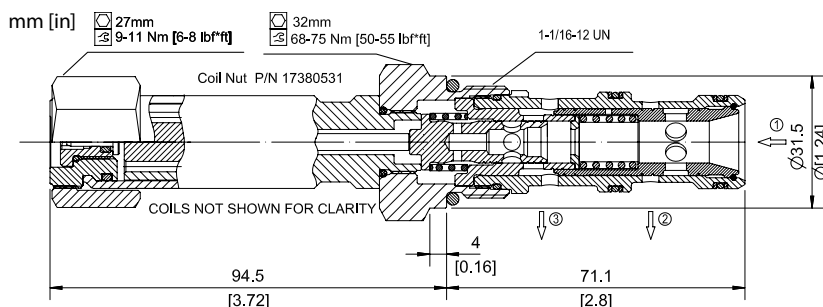

PERFORMANCE DATA

Rated pressure*	260 bar [3800 psi]
Max Regulated Flow	65 l/min [17 US gpm]
Leakage	420 ml/min [25.6 in ³ /min] @rated pressure
Maximum Hysteresis	8%
Threshold current	0.5 A [12 VDC coil] 0.25 A [24 VDC coil]
Maximum control current	1.8 A [12 VDC coil] 0.9 A [24 VDC coil]
Coil Options	D14E [35 Watt]
Weight	0.81 kg [1.79 lb]
Cavity	SDC12-3

*Rated pressure based on NFPA fatigue test standards (at 1 million cycles)

PERFORMANCE CURVES

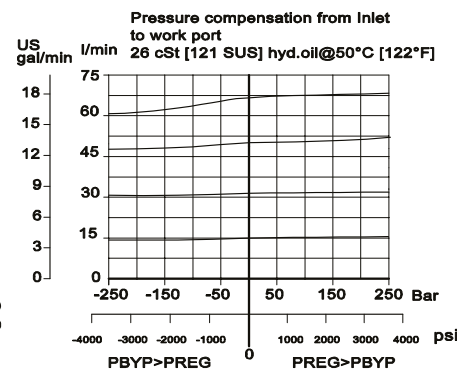
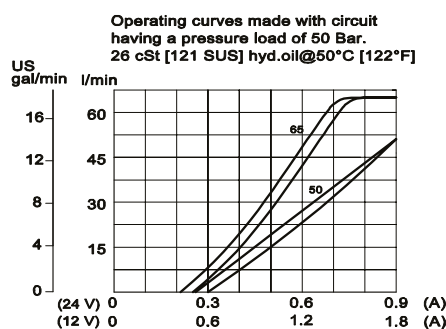

MODEL CODE

PFC12-PC-65-12D-DE-SPS-B-00

Max Regulated Flow

Code	Flow
50	50 l/min [13 US gpm]
65	65 l/min [17 US gpm]

Coil Voltage

00 - No coil, nut included*
12D - 12 VDC
24D - 24 VDC

*Aluminum coil nut (p/n 17380531)

Connector Type

00 - No coil
AJ - AMP Junior
DE - Deutsch
DN - DIN 43650

Manual Override Option

Omit - Push Pin
SPS - Screw Type

Housing

Code	Ports & Material	Housing Model Code
00	No housing	
10S	AL, #10 SAE	CP12-3-10S
12S	AL, #12 SAE	CP12-3-12S
4B	AL, 1/2 BSP	SDC12-3-HE 1/2
6B	AL, 3/4 BSP	SDC12-3-HE 3/4

*Aluminum bodies are to be used for pressures less than 210 bar [3000 psi].

*Additional housings available

Seal Option

Code	Seal kit
B - Buna - N	354008319
V - Viton	354008419

Proportional Valves

EFV2-12-C

Proportional Flow Control Valve, Normally Closed, Priority Type, Pressure Compensated

210 bar [3000 psi] • 57 l/min [15 US gpm]

DESCRIPTION AND OPERATION

This is a 3-way, spool type, normally closed, priority type, pressure compensated proportional flow control valve. In the de-energized condition, flow is blocked from port 1 to the priority port 3 and all flow passes from port 1 to 2. Energizing the coil will proportionally move the spool, opening a variable orifice from port 1 to 3, while excess flow passes to port 2. An internal compensating spool ensures that the output flow at port 3 remains constant, regardless of changes in differential pressure between port 1 and 3 or pressure at the bypass port 2. Increasing the current to the coil will increase the priority outlet flow.

SCHEMATIC

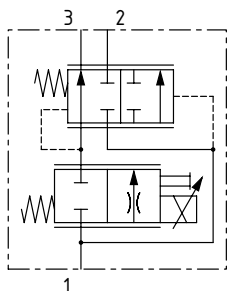

PERFORMANCE DATA

Rated pressure*	210 bar [3000 psi]
Max regulated flow	57 l/min [15 US gpm]
Leakage	240 ml/min @ 210 bar [3000 psi]
Maximum Hysteresis	13%
Recommended PWM frequency	200-400 Hz
Threshold current	350 mA [12 VDC coil] 175 mA [24 VDC coil]
Maximum control current	1.6 A [12 VDC coil] 0.8 A [24 VDC coil]
Coil Options	E series
Weight	0.37 kg [0.82 lb]
Cavity	C-12-3

*Rated pressure based on NFPA fatigue test standards (at 1 million cycles)

PERFORMANCE CURVES

Flow vs Pressure drop
Excess flow P1 to P2 (P3 to Atm)
Full current (1700 mA on a 12V Coil)

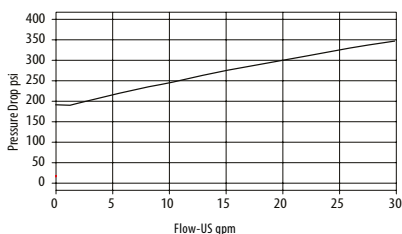

Flow vs Pressure drop
Regulated flow P1 to P3 (P2 to Atm)
Full current (1700 mA on a 12V Coil)

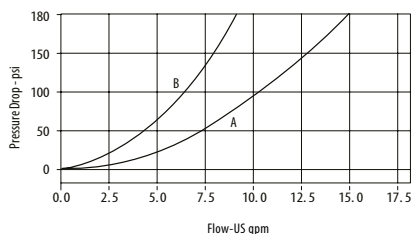

A - A spool pressure drop
B - B spool pressure drop

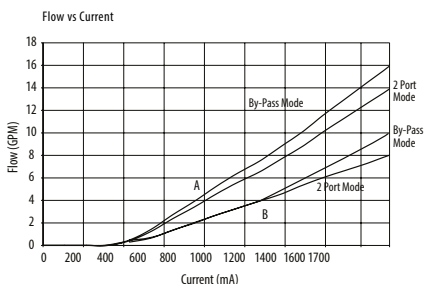

A - A spool
B - B spool

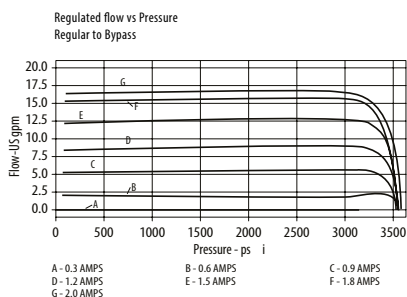

A - 0.3 AMPS B - 0.6 AMPS C - 0.9 AMPS
D - 1.2 AMPS E - 1.5 AMPS F - 1.8 AMPS
G - 2.0 AMPS

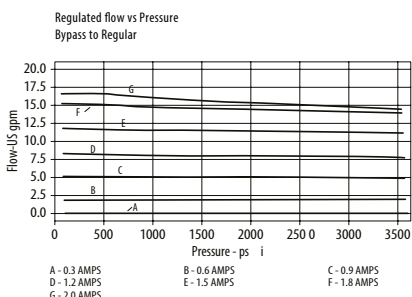

A - 0.3 AMPS B - 0.6 AMPS C - 0.9 AMPS
D - 1.2 AMPS E - 1.5 AMPS F - 1.8 AMPS
G - 2.0 AMPS

Note: Pressure Compensation curves are shown for "B" spool valves.

Proportional Valves

EFV2-12-C

Proportional Flow Control Valve, Normally Closed, Priority Type, Pressure Compensated

210 bar [3000 psi] • 57 l/min [15 US gpm]

■ DIMENSIONS

mm [in]

Coil Nut Torque

4.5-5.5 N [40-49 in lb]

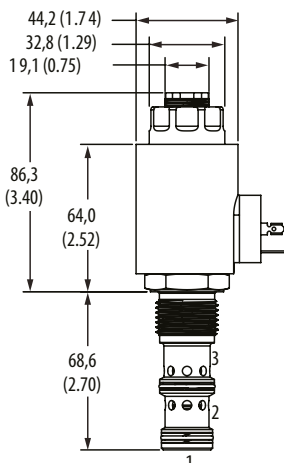

Installation torque

A - 81-95 Nm [60-70 ft. lbs]

S - 102-115 Nm [75-85 ft. lbs]

■ MODEL CODE

EFV2 - 12 - N - C - A - S - A - 04G - 12D - G - A - E

Seal Option

Code	Seal kit
N - Buna - N	9900171-000
V - Viton	9900172-000

Max regulated flow

Code	Flow
A	57 l/min [15 US gpm]
B	38 l/min [10 US gpm]

Manual Override Option

0 - No manual override
S - Screw Type

Housing Material

0 - No housing
A - Aluminium
S - Steel

Coil Series

0 - No coil
E - E series

Lead Wire Length (W connector type only)

0 - None
A - 152mm [6.0 in]
(standard length with connector)
B - 610mm [24.0 in]
(standard length without connector)

Connector Type

0 - No coil
G - DIN 43650
W - Flying lead
C - Deutsch Male (DT04-2P), On wire leads

Coil Voltage

00 - No coil, nut included (p/n 6034634-001)
12D - 12 VDC
24D - 24 VDC

Housing

Code	Ports	Aluminium	Steel
0	No housing		
04G	1/2" BSP	02-161817	02-169815
06G	3/4" BSP	02-161816	02-169814
10T	#10 SAE	02-160642	02-161070
12T	#12 SAE	02-160646	02-169816

* Aluminum bodies are to be used for pressures less than 210 bar [3000 psi].

* Additional housings available

Proportional Valves

PFC16-PC

Proportional Flow Control Valve, Normally Closed, Priority Type, Pressure Compensated

260 bar [3800 psi] • 85 l/min [22.5 US gpm]

DESCRIPTION AND OPERATION

This is a 3-way, spool type, normally closed, priority type, pressure compensated proportional flow control valve. In the de-energized condition, flow is blocked from port 1 to the priority port 3 and all flow passes from port 1 to 2. Energizing the coil will proportionally move the spool, opening a variable orifice from port 1 to 3, while excess flow passes to port 2. An internal compensating spool ensures that the output flow at port 3 remains constant, regardless of changes in differential pressure between port 1 and 3 or pressure at the bypass port 2. Increasing the current to the coil will increase the priority outlet flow.

SCHEMATIC

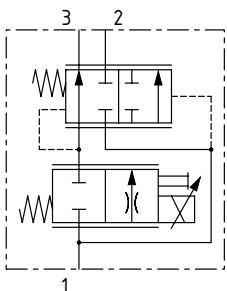

DIMENSIONS

mm [in]

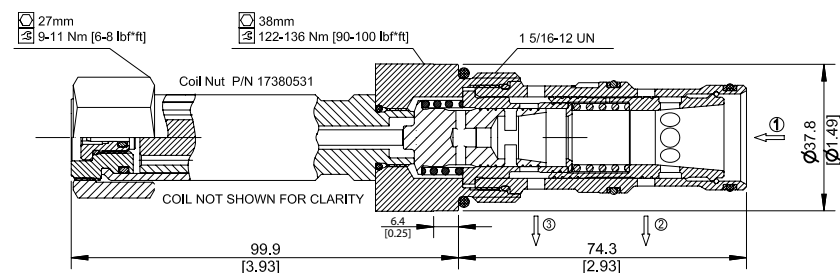

PERFORMANCE DATA

Rated pressure*	260 bar [3800 psi]
Max regulated flow	85 l/min [22.5 US gpm]
Leakage	420 ml/min [25.6 in ³ /min] @rated pressure
Maximum Hysteresis	8%
Threshold current	0.4 A [12 VDC coil] 0.2 A [24 VDC coil]
Maximum control current	1.8 A [12 VDC coil] 0.9 A [24 VDC coil]
Coil Options	D14E [35 Watt]
Weight	0.97 kg [2.14 lb]
Cavity	SDC16-3

*Rated pressure based on NFPA fatigue test standards (at 1 million cycles)

PERFORMANCE CURVES

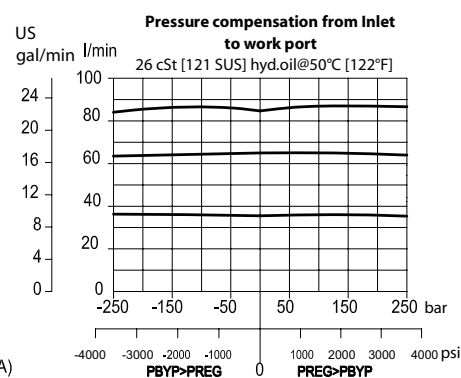
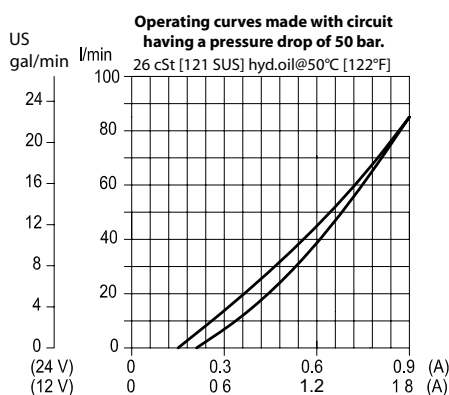

MODEL CODE

PFC16-PC-85-12D-DN-SPS-B-00

Max Regulated flow

Code	Flow
85	85 l/min (22.5 US gpm)

Coil Voltage

00 - No coil, nut included*

12D - 12 VDC

24D - 24 VDC

*Aluminum coil nut (p/n 17380531)

Connector Type

00 - No coil

AJ - AMP Junior

DE - Deutsch

DN - DIN 43650

Manual Override Option

Omit - Push Pin

SPS - Screw Type

Housing

Code	Ports & Material	Housing Model Code
00	No housing	
6B	AL, 3/4 BSP	SDC16-3-HE-6B
8B	AL, 1 BSP	SDC16-3-HE-8B
12S	AL, #12 SAE	CP16-3-12S
16S	AL, #16 SAE	CP16-3-16S

* Aluminum bodies are to be used for pressures less than 210 bar [3000 psi].

* Additional housings available

Seal Option

Code	Seal kit
B - Buna - N	354008919
V - Viton	354009019

Proportional Valves

PFC10-PO

Proportional Flow Control Valve, Normally Open, Priority Type, Pressure Compensated

260 bar [3800 psi] • 35 l/min [9.2 US gpm]

DESCRIPTION AND OPERATION

This is a 3-way, spool type, normally open, priority type, pressure compensated proportional flow control valve. In the de-energized condition, port 1 is open to port 3 to the rated controlled flow and excess flow passes to port 2. Energizing the coil will proportionally move the spool, restricting flow through a variable orifice from port 1 to 3, while excess flow passes to port 2. An internal compensating spool ensures that the output flow at port 3 remains constant, regardless of changes in differential pressure between port 1 and 3 or pressure at the bypass port 2. Increasing the current to the coil will decrease the priority outlet flow.

SCHEMATIC

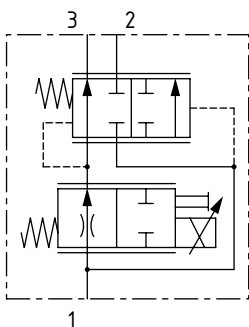

DIMENSIONS

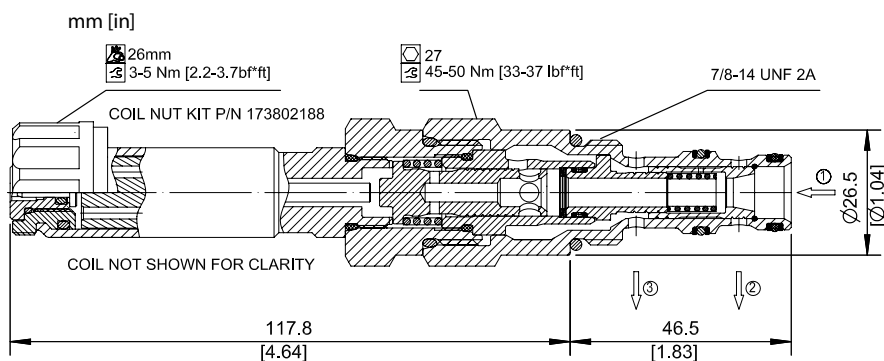

PERFORMANCE DATA

Rated pressure*	260 bar [3800 psi]
Max Regulated Flow	35 l/min [9.2 US gpm]
Leakage	420 ml/min [25.6 in ³ /min] @rated pressure
Maximum Hysteresis	8%
Threshold current	0.1 A [12 VDC coil] 0.05 A [24 VDC coil]
Maximum control current	1.8 A [12 VDC coil] 0.9 A [24 VDC coil]
Coil Options	M19P
Weight	0.72 kg [1.59 lb]
Cavity	SDC10-3

*Rated pressure based on NFPA fatigue test standards (at 1 million cycles)

PERFORMANCE CURVES

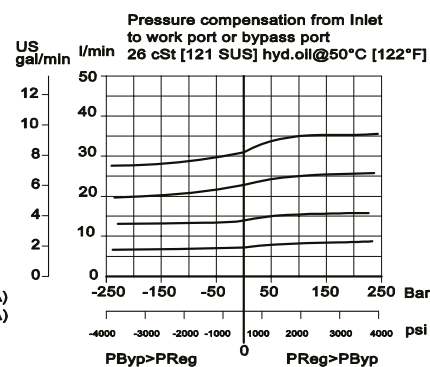
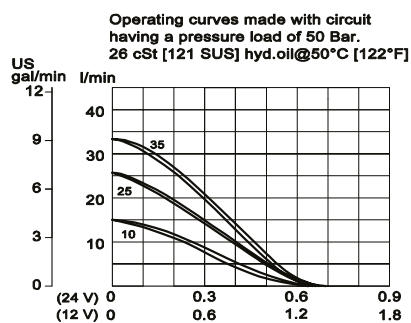

MODEL CODE

PFC10 - PO - 35 - 12D - DN - SPS - B - 6S

Max Regulated Flow

Code	Flow
10	10 l/min [2.6 US gpm]
25	25 l/min [6.6 US gpm]
35	35 l/min [9.2 US gpm]

Coil Voltage

00 - No coil, nut included*
12D - 12 VDC
24D - 24 VDC

*Standard Coil - Plastic coil nut and o-rings (p/n 173802188)

Connector Type

00 - No coil
AJ - AMP Junior
DE - Deutsch
DN - DIN 43650

Manual Override Option

Omit - Push Pin
SPS - Screw Type

Housing

Code	Ports & Material	Housing Model Code
00	No housing	
6S	AL, #6 SAE	CP10-3-6S
8S	AL, #8 SAE	CP10-3-8S
SE3B	AL, 3/8 BSP	SDC10-3-SE3B
SE4B	AL, 1/2 BSP	SDC10-3-SE4B

* Aluminum bodies are to be used for pressures less than 210 bar [3000 psi].

* Additional housings available

Seal Option

Code	Seal kit
B - Buna - N	35400421
V - Viton	35400371

Proportional Valves

PFC12-PO

Proportional Flow Control Valve, Normally Open, Priority Type, Pressure Compensated

260 bar [3800 psi] • 70 l/min [18.5 US gpm]

DESCRIPTION AND OPERATION

This is a 3-way, spool type, normally open, priority type, pressure compensated proportional flow control valve. In the de-energized condition, port 1 is open to port 3 to the rated controlled flow and excess flow passes to port 2. Energizing the coil will proportionally move the spool, restricting flow through a variable orifice from port 1 to 3, while excess flow passes to port 2. An internal compensating spool ensures that the output flow at port 3 remains constant, regardless of changes in differential pressure between port 1 and 3 or pressure at the bypass port 2. Increasing the current to the coil will decrease the priority outlet flow.

SCHEMATIC

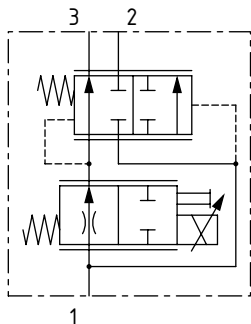

DIMENSIONS

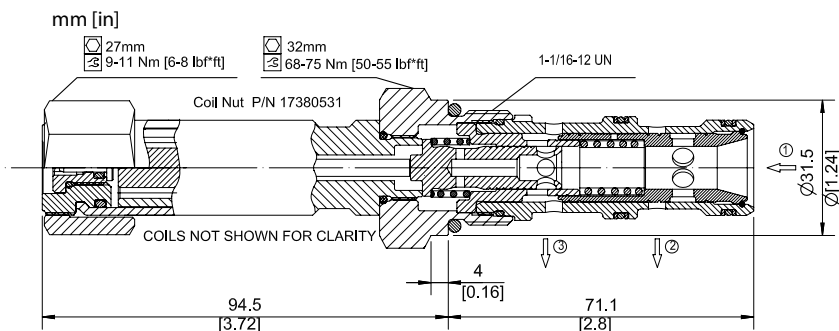

PERFORMANCE DATA

Rated pressure*	260 bar [3800 psi]
Max Regulated flow	70 l/min [18.5 US gpm]
Leakage	420 ml/min [25.6 in ³ /min]
Maximum Hysteresis	8%
Threshold current	0.2 A [12 VDC coil] 0.1 A [24 VDC coil]
Maximum control current	1.8 A [12 VDC coil] 0.9 A [24 VDC coil]
Coil Options	D14E [35 Watt]
Weight	0.81 kg [1.79 lb]
Cavity	SDC12-3

*Rated pressure based on NFPA fatigue test standards (at 1 million cycles)

PERFORMANCE CURVES

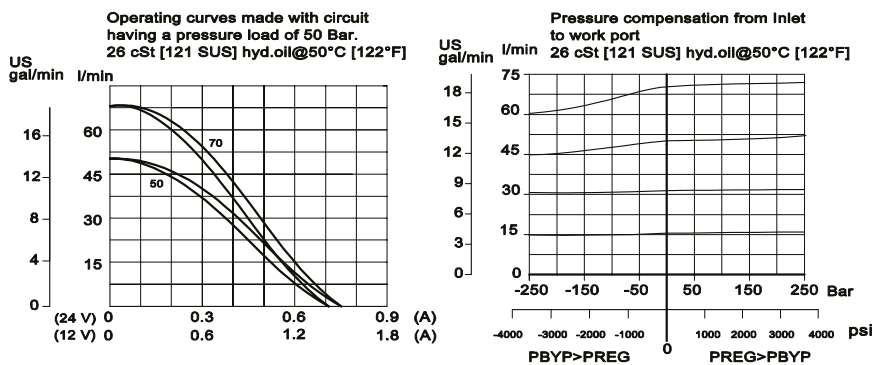

MODEL CODE

PFC12 - PO - 70 - 12D - DN - SPS - B - 00

Max Regulated Flow

Code	Flow
50	50 l/min [13 US gpm]
70	70 l/min [18.5 US gpm]

Coil Voltage

00 - No coil, nut included*
12D - 12 VDC
24D - 24 VDC

*Aluminum coil nut (p/n 17380531)

Connector Type

00 - No coil
AJ - AMP Junior
DE - Deutsch
DN - DIN 43650

Manual Override Option

Omit - Push Pin
SPS - Screw Type

Housing

Code	Ports & Material	Housing Model Code
00	No housing	
10S	AL, #10 SAE	CP12-3-10S
12S	AL, #12 SAE	CP12-3-12S
4B	AL, 1/2 BSP	SDC12-3-HE 1/2
6B	AL, 3/4 BSP	SDC12-3-HE 3/4

*Aluminum bodies are to be used for pressures less than 210 bar [3000 psi].

*Additional housings available

Seal Option

Code	Seal kit
B - Buna - N	354008319
V - Viton	354008419

Proportional Valves

EFV2-12-O

Proportional Flow Control Valve, Normally Open, Priority Type, Pressure Compensated

210 bar [3000 psi] • 53 l/min [14 US gpm]

DESCRIPTION AND OPERATION

This is a 3-way, spool type, normally open, priority type, pressure compensated proportional flow control valve. In the de-energized condition, port 1 is open to port 3 to the rated controlled flow and excess flow passes to port 2. Energizing the coil will proportionally move the spool, restricting flow through a variable orifice from port 1 to 3, while excess flow passes to port 2. An internal compensating spool ensures that the output flow at port 3 remains constant, regardless of changes in differential pressure between port 1 and 3 or pressure at the bypass port 2. Increasing the current to the coil will decrease the priority outlet flow.

SCHEMATIC

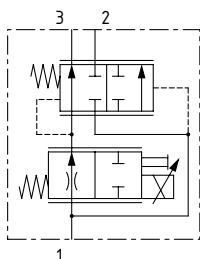

PERFORMANCE DATA

Rated pressure*	210 bar [3000 psi]
Max Regulated flow	53 l/min [14 US gpm]
Leakage	240 ml/min (15 in ³ /min) at 210 bar [3000 psi]
Recommended PWM frequency	200-400 Hz
Maximum Hysteresis	13%
Threshold current	150 mA [12 VDC coil] 75 mA [24 VDC coil]
Maximum control current	1.6 A [12 VDC coil] 0.8 A [24 VDC coil]
Coil Options	E series
Weight	0.37 kg [0.82 lb]
Cavity	C-12-3

*Rated pressure based on NFPA fatigue test standards (at 1 million cycles)

PERFORMANCE CURVES

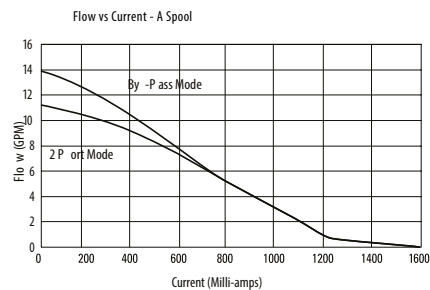
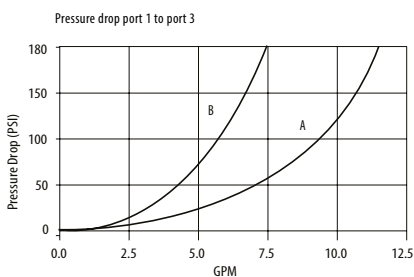
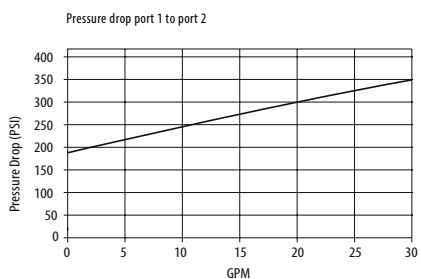

Parameters: 400 Hz PWM

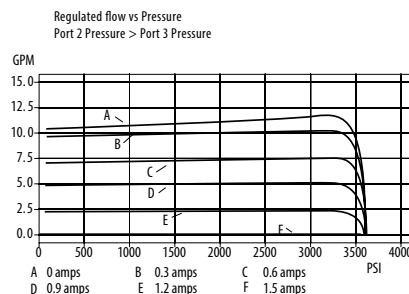
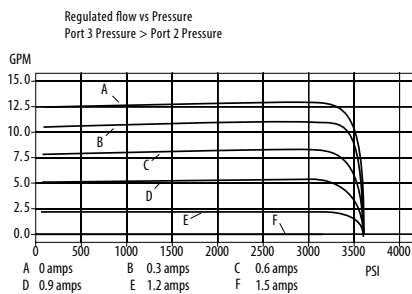
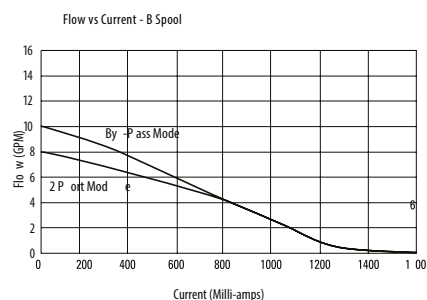

Note: Pressure Compensation curves are shown for "B" spool valves.

Proportional Valves

EFV2-12-O

Proportional Flow Control Valve, Normally Open, Priority Type, Pressure Compensated

210 bar [3000 psi] • 53 l/min [14 US gpm]

■ DIMENSIONS

mm [in]

Coil nut torque

4.5-5.5 Nm [40-49 in lbs]

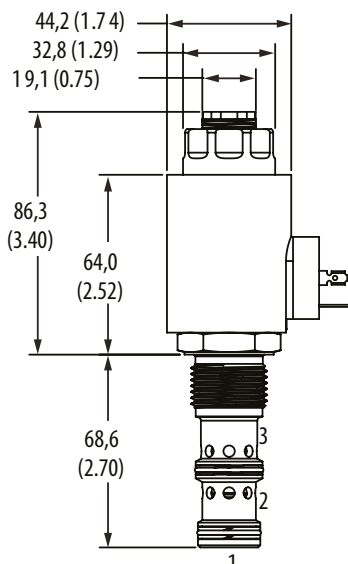

Installation torque

A - 81-95 Nm [60-70 ft. lbs]

S - 102-115 Nm [75-85 ft. lbs]

■ MODEL CODE

EFV2 - 12 - V - O - A - S - A - 12T - 12D - G - A - E

Seal Option

Code	Seal kit
Omit	Buna - N 9900171-000
V	Viton 9900172-000

Max Regulated flow

Code	Flow
A	53 l/min [14 US gpm]
B	38 l/min [10 US gpm]

Manual Override Option

O - No manual override
S - Screw Type

Housing Material

Omit - No housing
A - Aluminium
S - Steel

Coil series

Omit - No coil
E - E series coils

Lead Wire Length (W connector type only)

Omit - None
A - 152mm [6.0 in]
(standard length with connector)
B - 610mm [24.0 in]
(standard length without connector)

Connector Type

Omit - No coil
G - DIN 43650
W - Flying lead
C - Deutsch Male (DT04-2P), On wire leads

Coil Voltage

00 - No coil, nut included (p/n 6034634-001)
12D - 12 VDC
24D - 24 VDC

Housing

Code	Ports	Aluminium	Steel
0	No housing		
04G	1/2" BSP	02-161817	02-169815
06G	3/4" BSP	02-161816	02-169814
10T	#10 SAE	02-160642	02-161070
12T	#12 SAE	02-160646	02-169816

* Aluminum bodies are to be used for pressures less than 210 bar [3000 psi].

* Additional housings available

Proportional Valves

PFC16-PO

Proportional Flow Control Valve, Normally Open, Priority Type, Pressure Compensated

260 bar [3800 psi] • 90 l/min [24 US gpm]

DESCRIPTION AND OPERATION

This is a 3-way, spool type, normally open, priority type, pressure compensated proportional flow control valve. In the de-energized condition, port 1 is open to port 3 to the rated controlled flow and excess flow passes to port 2. Energizing the coil will proportionally move the spool, restricting flow through a variable orifice from port 1 to 3, while excess flow passes to port 2. An internal compensating spool ensures that the output flow at port 3 remains constant, regardless of changes in differential pressure between port 1 and 3 or pressure at the bypass port 2. Increasing the current to the coil will decrease the priority outlet flow.

SCHEMATIC

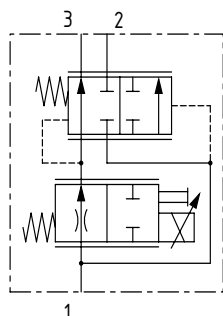

DIMENSIONS

mm [in]

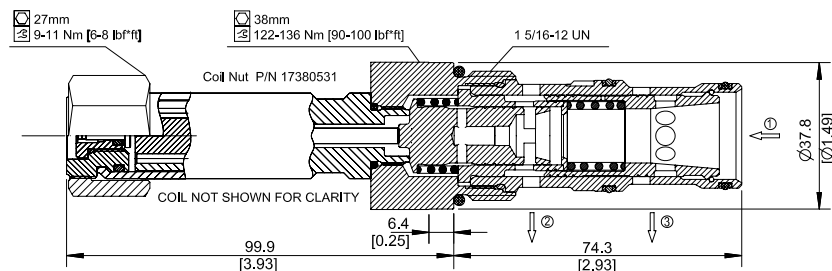

PERFORMANCE DATA

Rated pressure*	260 bar [3800 psi]
Max regulated flow	90 l/min [24 US gpm]
Leakage	420 ml/min [25.6 in ³ /min] @rated pressure
Maximum Hysteresis	8%
Threshold current	0.4 A [12 VDC coil] 0.2 A [24 VDC coil]
Maximum control current	1.8 A [12 VDC coil] 0.9 A [24 VDC coil]
Coil Options	D14E [35 Watt]
Weight	0.97 kg [2.14 lb]
Cavity	SDC16-3

*Rated pressure based on NFPA fatigue test standards (at 1 million cycles)

PERFORMANCE CURVES

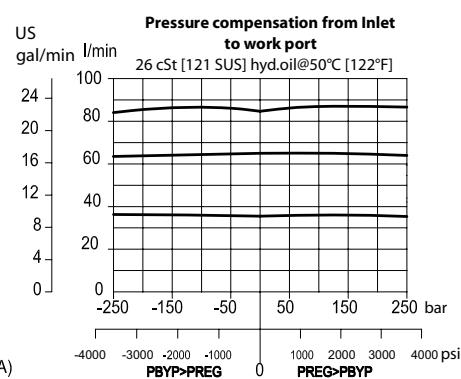
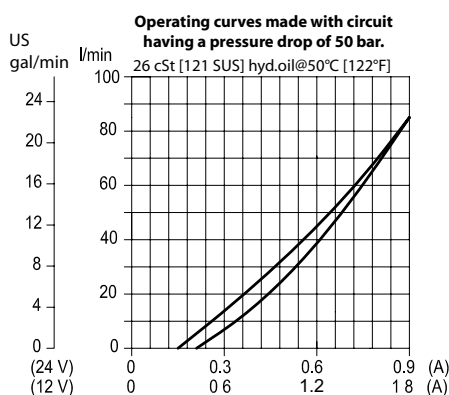

MODEL CODE

PFC16 - PO - 90 - 12D - DE - SPS - B - 6B

Max Regulated flow

Code	Flow
90	90 l/min [24 US gpm]

Coil Voltage

00 - No coil, nut included
12D - 12 VDC
24D - 24 VDC

*Aluminum coil nut (p/n 17380531)

Connector Type

00 - No coil
AJ - AMP Junior
DE - Deutsch
DN - DIN 43650

Manual Override Option

Omit - Push Pin
SPS - Screw Type

Housing

Code	Ports & Material	Housing Model Code
00	No housing	
6B	AL, 3/4 BSP	SDC16-3-HE6B
8B	AL, 1 BSP	SDC16-3-HE8B
12S	AL, #12 SAE	CP16-3-12S
16S	AL, #16 SAE	CP16-3-16S

* Aluminum bodies are to be used for pressures less than 210 bar [3000 psi].
* Additional housings available

Seal Option

Code	Seal kit
B - Buna - N	354008919
V - Viton	354009019

Proportional Valves

XMD 04

Proportional Relief Valve, Poppet Type, Direct Acting, Normally Open

250 bar [3600 psi] • 5 l/min [1.3 US gpm]

DESCRIPTION AND OPERATION

This is a direct acting, poppet type, normally open, proportional relief valve. In the de-energized condition, the pressure setting will be at a minimum. As current is applied to the coil, the pressure setting of the valve will increase proportionally. Backpressure at port 2 must be limited to 150 bar above the pressure at port 1 or the valve will not function. This valve is ideal for use as a pilot valve to control larger logic elements.

SCHEMATIC

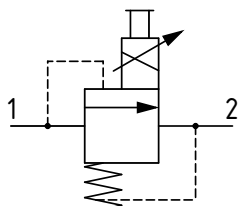

DIMENSIONS

mm [in]

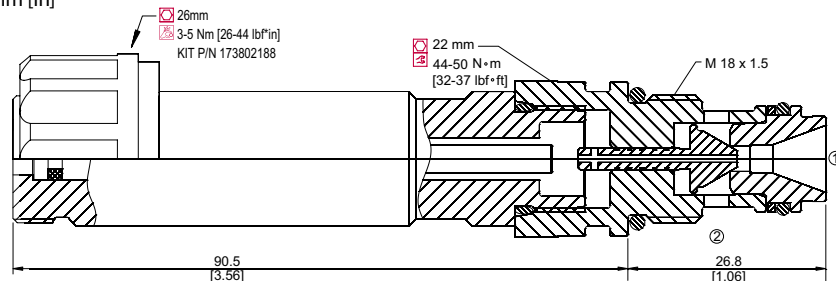

PERFORMANCE DATA

Rated pressure	250 bar [3600 psi]
Rated flow	5 l/min [1.3 US gpm]
Maximum Hysteresis	3%
Threshold current	0 A [12 VDC coil] 0 A [24 VDC coil]
Maximum control current	1.8 A [12 VDC coil] 0.9 A [24 VDC coil]
Coil Options	M19P
Weight	0.44 kg [0.97 lb]
Cavity	NCS04/2

PERFORMANCE CURVES

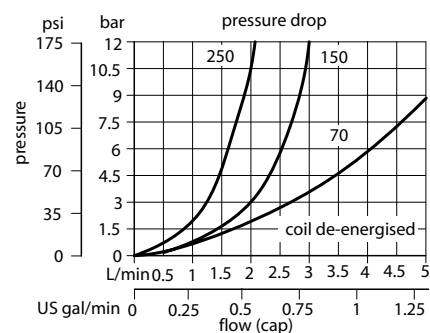
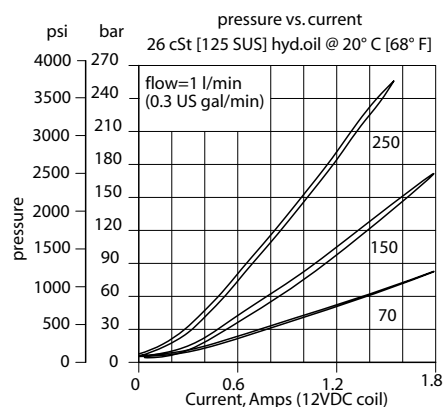

MODEL CODE

XMD 04 - 70 - 24D - DE - EN - 00 - V

Max Pressure Option

Code	Pressure Range
70	3-70 bar [44-1015 psi]
150	5-150 bar [73-2176 psi]
250	7-250 bar [102-3600 psi]

Coil Voltage

00 - No coil, nut included*
12D - 12 VDC
24D - 24 VDC

*Standard Coil - Plastic coil nut and o-rings (p/n 173802188)

Connector Type

00 - No coil
AJ - AMP Junior
DE - Deutsch
DN - DIN 43650

Manual Override Option

00 - Push Pin
EN - Screw Type

Seal Option

Code	Seal kit
Omit	Buna - N 230000390
V	Viton 230000190

Housing

Code	Ports & Material	Housing Model Code
00	No housing	
DG-45	AL, #4 SAE	NCS04/2-DG-45
DG-65	AL, #6 SAE	NCS04/2-DG-65
DG-1/4	AL, 1/4 BSP	NCS04/2-DG-1/4

* Aluminum bodies are to be used for pressures less than 210 bar [3000 psi].

* Additional housings available

Proportional Valves

XMP 06

Proportional Relief Valve, Spool Type, Pilot Operated, Normally Open

315 bar [4500 psi] • 50 l/min [13 US gpm]

DESCRIPTION AND OPERATION

This is a pilot operated, spool type, normally open, proportional relief valve. In the de-energized condition, the pressure setting will be at a minimum. As current is applied to the coil, the pressure setting of the valve will increase proportionally. This valve is ideal for system pressure control where flows may vary.

SCHEMATIC

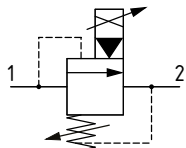

DIMENSIONS

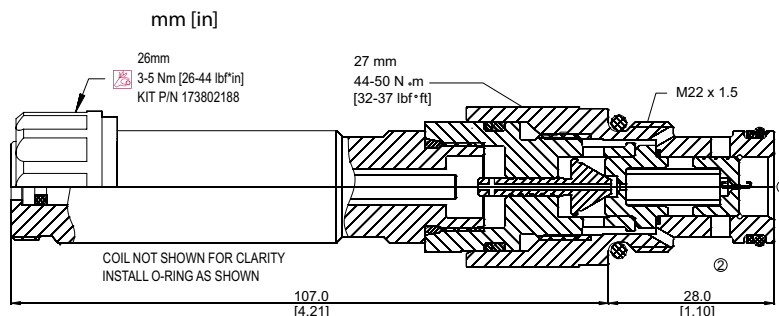

PERFORMANCE DATA

Rated pressure	315 bar [4500 psi]
Rated Flow	50 l/min [13 US gpm]
Maximum Hysteresis	3%
Threshold current	0 A [12 VDC coil] 0 A [24 VDC coil]
Maximum control current	1.8 A [12 VDC coil] 0.9 A [24 VDC coil]
Coil Options	M19P
Weight	0.53 kg [1.17 lb]
Cavity	NCS 06/2

PERFORMANCE CURVES

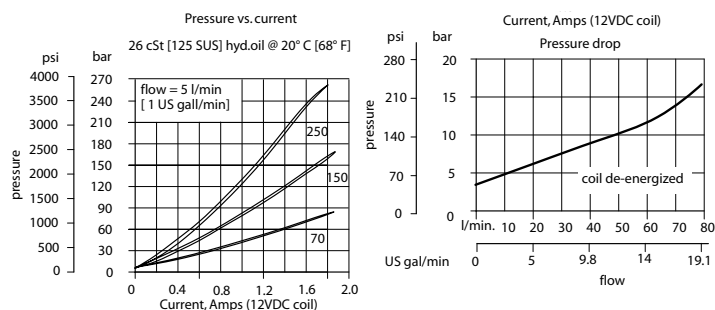

MODEL CODE

XMP 06 - 70 - 24D - DE - EN - 00 - V

Max Pressure Option

Code	Pressure Range
70	3-70 bar [44-1015 psi]
150	5-150 bar [73-2176 psi]
250	7-250 bar [102-3600 psi]

Coil Voltage

00 - No coil, nut included*
12D - 12 VDC
24D - 24 VDC

*Standard Coil - Plastic coil nut and o-rings (p/n 173802188)

Connector Type

00 - No coil
AJ - AMP Junior
DE - Deutsch
DN - DIN 43650

Manual Override Option

00 - Push Pin
EN - Screw Type

Seal Option

Code	Seal kit
Omit	Buna - N 230000380
V	Viton 230000060

Housing

Code	Ports & Material	Housing Model Code
00	No housing	
DG-6S	AL, #6 SAE	NCS06/2-DG-6S
DG-8S	AL, #8 SAE	NCS06/2-DG-8S
DG-3/8	AL, 3/8 BSP	NCS06/2-DG-3/8
DG-1/2	AL, 1/2 BSP	NCS06/2-DG-1/2

* Aluminum bodies are to be used for pressures less than 210 bar [3000 psi].

* Additional housings available

Proportional Valves

PAR1-10

Proportional Relief Valve, Spool Type, Pilot Operated, Normally Open

240 bar [3500 psi] • 57 l/min [15 US gpm]

DESCRIPTION AND OPERATION

This is a pilot operated, spool type, normally open, proportional relief valve. In the de-energized condition, the pressure setting will be at a minimum. As current is applied to the coil, the pressure setting of the valve will increase proportionally. This valve is ideal for system pressure control where flows may vary.

SCHEMATIC

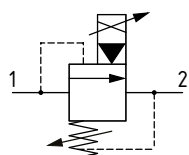

PERFORMANCE DATA

Rated pressure*	240 bar [3500 psi]
Rated flow	57 l/min [15 US gpm]
Leakage	120 ml/min [7.3 in ³ /min] @ 80% of Pressure Setting
Pressure Range	7-210 bar [100-3000 psi]
Maximum Hysteresis	10%
Recommended PWM frequency	100 Hz
Threshold current	0 A
Maximum control current	2.0 A [12 VDC coil] 1.0 A [24 VDC coil]
Coil Options	J series
Weight	0.44 kg [0.98 lb]
Cavity	SDC10-2

*Rated pressure based on NFPA fatigue test standards (at 1 million cycles)

MODEL CODE

PAR1 - 10 - V - 10 - 0 - 12D - G - J

Seal Option

Code	Seal kit
Omit - Buna - N	565803
V - Viton	566086

Max Pressure Setting

Code x 100 - Pressure setting in psi [100 psi increments within specified Pressure Range]
Pressure Range: 7-210 bar [100-3000 psi]
 Example:

Code	Bar	Psi
10	69	[1000 psi]

Housing

Code	Ports	Aluminium
0	No housing	
6T	#6 SAE	566151
2G	1/4" BSP	876702
3G	3/8" BSP	876703
6H	#6 SAE	876700
8H	#8 SAE	876701

* Aluminum bodies are to be used for pressures less than 210 bar [3000 psi].

* Additional housings available

DIMENSIONS

mm [in]

Coil Nut Torque

5-8 Nm [4-6 ft lbs]

Installation torque

A - 47-54 Nm [35-40 ft lbs]

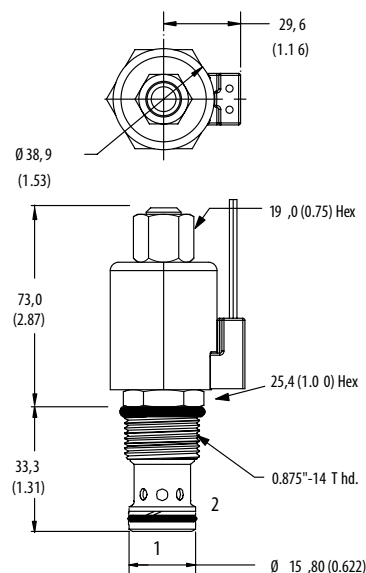

PERFORMANCE CURVES

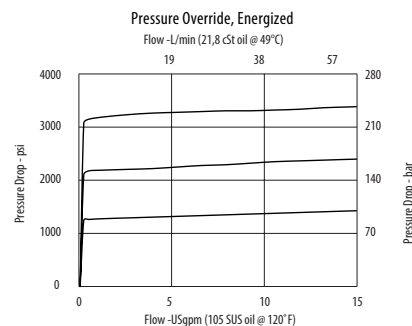
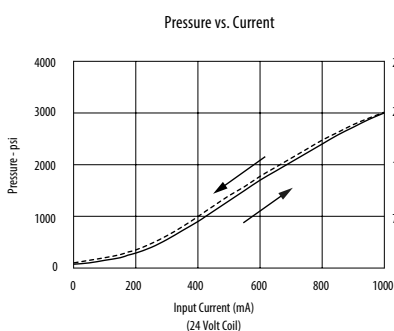

Proportional Valves

PAR1-16

Proportional Relief Valve, Spool Type, Pilot Operated, Normally Open

210 bar [3000 psi] • 132 l/min [35 US gpm]

DESCRIPTION AND OPERATION

This is a pilot operated, spool type, normally open, proportional relief valve. In the de-energized condition, the pressure setting will be at a minimum. As current is applied to the coil, the pressure setting of the valve will increase proportionally. This valve is ideal for system pressure control where flows may vary.

SCHEMATIC

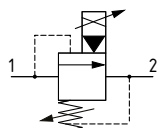

PERFORMANCE DATA

Rated pressure*	210 bar [3000 psi]
Rated flow	132 l/min [35 US gpm]
Leakage	130 ml/min [8 in ³ /min] @ 80% of pressure setting
Pressure Range	7-210 bar [100-3000 psi]
Maximum Hysteresis	10%
Threshold current	0 A
Maximum control current	2.0 A [12 VDC coil] 1.0 A [24 VDC coil]
Coil Options	J series
Weight	0.44 kg [0.98 lb]
Cavity	SDC16-2

*Rated pressure based on NFPA fatigue test standards (at 1 million cycles)

MODEL CODE

PAR1 - 16 - V - 10 - 0 - 12D - G - J

Seal Option

Code	Seal kit
Omit - Buna - N	565810
V - Viton	889609

Max Pressure Setting

Code x 100 - Pressure setting in psi [100 psi increments within specified Pressure Range]
Pressure Range: 7-210 bar [100-3000 psi]
 Example:

Code	Bar	Psi
10	69	[1000 psi]

Housing

Code	Ports	Aluminum
0	No housing	
12T	#12 SAE	566149
4G	1/2" BSP	876716
6G	3/4" BSP	876718
10H	#10 SAE	876717
12H	#12 SAE	566113

* Aluminum bodies are to be used for pressures less than 210 bar [3000 psi].

* Additional housings available

DIMENSIONS

mm [in]

Coil Nut Torque
5-8 Nm [4-6 ft lbs]

Installation torque
A - 108-122 Nm [80-90 ft lbs]

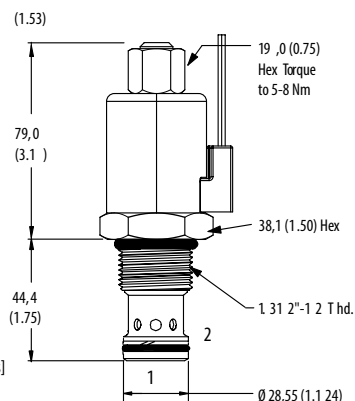

PERFORMANCE CURVES

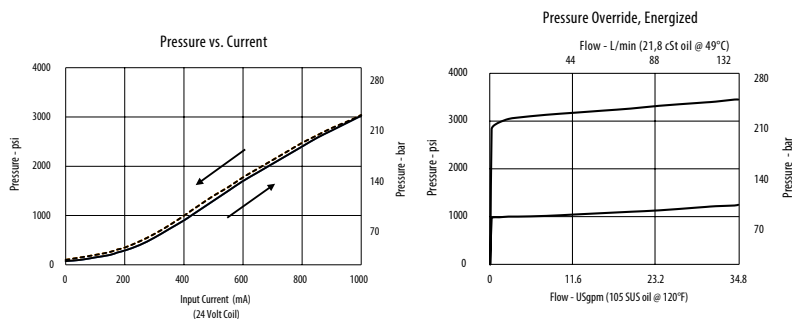

Proportional Valves

PRV08-DAC

Proportional Relief Valve, Poppet Type, Direct Acting, Normally Closed

215 bar [3100 psi] • 3.8 l/min [1 US gpm]

DESCRIPTION AND OPERATION

This is a direct acting, poppet type, normally closed, proportional relief valve. In the de-energized condition, the pressure setting will be at a maximum. As current is applied to the coil, the pressure setting of the valve will decrease proportionally. This valve is ideal for use as a pilot valve to control larger logic elements.

SCHEMATIC

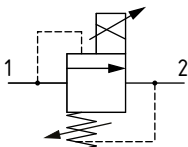

DIMENSIONS

mm [in]

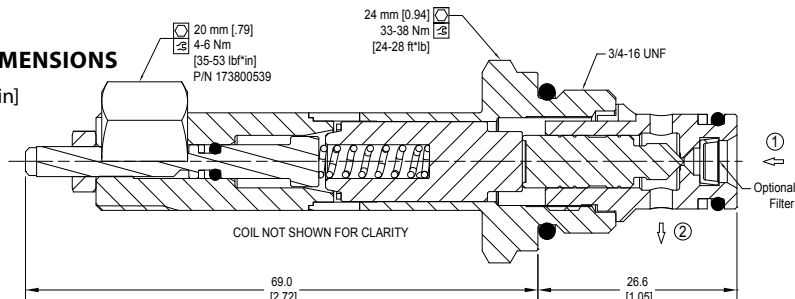

*Adjustment nut torque
4 Nm [36 in lbs]

PERFORMANCE DATA

Rated pressure*	215 bar [3100 psi]
Rated flow**	3.8 l/min [1 US gpm]
Max recommended flow	'B' option: 3.78 l/min [1.0 US gpm] 'C' option: 2.84 l/min [0.75 US gpm]
Recommended PWM frequency	50 Hz
Maximum Hysteresis	5%
Threshold current	0 A [12 VDC coil] 0 A [24 VDC coil]
Maximum control current (R13)	0.8 A [12 VDC coil] 0.4 A [24 VDC coil]
Maximum control current (M13)	1.1 A [12 VDC coil] 0.55 A [24 VDC coil]
Coil Options	M13, R13
Weight	0.1 kg [0.23 lb]
Cavity	SDC08-2

*Rated pressure based on NFPA fatigue test standards (at 1 million cycles)

** Minimum flow of 1 l/min (0.25 US gpm) recommended

PERFORMANCE CURVES

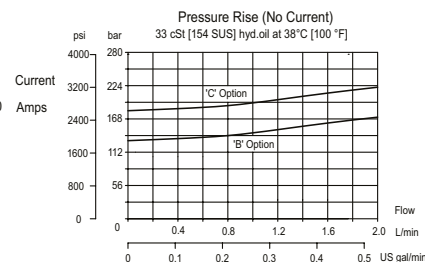
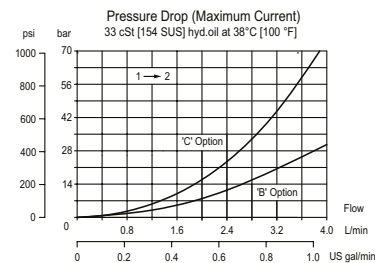
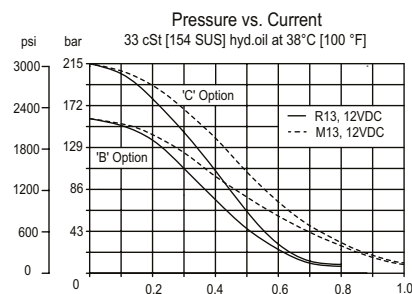

MODEL CODE

PRV08 - DAC - 215 - C - E - 12D - AJ - V - F - S6S

Max Pressure Setting

Code - Pressure setting in bar
(5 bar increments within specified Pressure Range)
Example:

Code	Bar	Psi
65	65	[940]

Pressure Range

Code	Pressure Range
B	65-155 bar [940-2250 psi]
C	155-215 bar [2250-3100 psi]

Adjustment Option

E - External

Coil Voltage

Standard Coil Code	Robust Coil Code	Coil Voltage
00	R00	No Coil, nut included*
12D	R12D	12 VDC
24D	R24D	24 VDC

*Standard Coil - Plastic coil nut and o-rings (p/n 173800588)

*Robust Coil - Steel coil nut and no o-rings (p/n 173800539)

Connector Type

Standard Coil Code	Robust Coil Code	Connector Type
00	R00	No Coil
AJ		Amp Junior
AS	AS	AMP SuperSeal 1.5
DE	DE	Deutsch
FL	FL	Flying Leads
DN		DIN 43650

Housing

Code	Ports & Material	Housing Model Code
00	No housing	
4S	#4 SAE, AL	CP08-2-4S
6S	#6 SAE, AL	CP08-2-6S
DG2B	1/4 BSP, AL	SDC08-2-DG2B
DG3B	3/8 BSP, AL	SDC08-2-DG3B
S4S	#4 SAE, DUCTILE	CP08-2-S4S
S6S	#6 SAE, DUCTILE	CP08-2-S6S

* Aluminum bodies are to be used for pressures less than 210 bar [3000 psi].

* Additional housings available

Filter Option

F - Filter
Omit - No Filter

Seal Option

Code	Seal kit
B - Buna - N	11191986
V - Viton	11191987

Proportional Valves

HPRV08-DAC

Proportional Relief Valve, Poppet Type, Direct Acting, Normally Closed

350 bar [5000 psi] • 1.9 l/min [0.5 US gpm]

DESCRIPTION AND OPERATION

This is a direct acting, poppet type, normally closed, proportional relief valve. In the de-energized condition, the pressure setting will be at a maximum. As current is applied to the coil, the pressure setting of the valve will decrease proportionally. This valve is ideal for use as a pilot valve to control larger logic elements.

SCHEMATIC

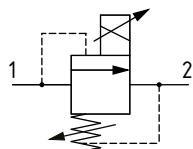

DIMENSIONS

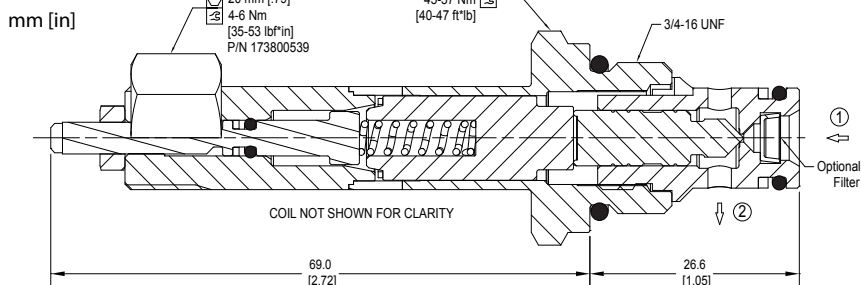

*Adjustment nut torque
4 Nm [36 in lbs]

PERFORMANCE DATA

Rated pressure*	350 bar [5000 psi]
Rated flow**	1.9 l/min [0.5 US gpm]
Recommended PWM frequency	50 Hz
Maximum Hysteresis	5%
Threshold current	0 A
Maximum control current (R13)	0.8 A [12 VDC coil] 0.4 A [24 VDC coil]
Maximum control current (M13)	1.1 A [12 VDC coil] 0.55 A [24 VDC coil]
Coil Options	M13, R13
Weight	0.1 kg [0.23 lb]
Cavity	SDC08-2

*Rated pressure based on NFPA fatigue test standards (at 1 million cycles)

**Minimum flow of 1 l/min (0.25 US gpm) recommended

PERFORMANCE CURVES

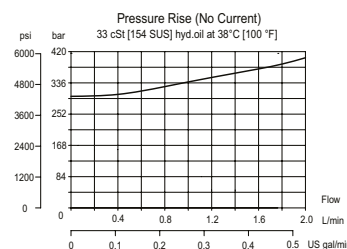
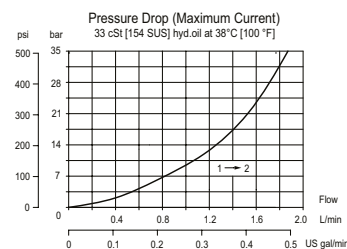
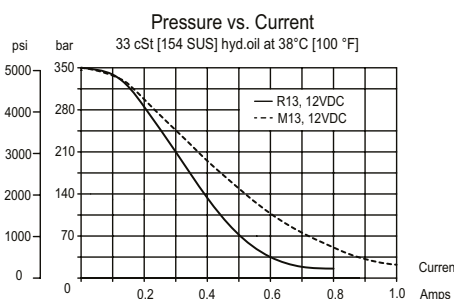

MODEL CODE

HPRV08 - DAC - 350 - D - E - R12D - DE - B - F - S4S

Max Pressure Setting

Code - Pressure setting in bar
(5 bar increments within specified Pressure Range)
Example:

Code	Bar	Psi
350	350	[5000]

Pressure Range

Code	Pressure Range
D	215-350 bar [3100-5000 psi]

Actuator Options

E - External

Coil Voltage

Standard Coil Code	Robust Coil Code	Coil Voltage
00	R00	No Coil, nut included*
12D	R12D	12 VDC
24D	R24D	24 VDC

*Standard Coil - Plastic coil nut and o-rings (p/n 173800588)

*Robust Coil - Steel coil nut and no o-rings (p/n 173800539)

Connector Type

Standard Coil Code	Robust Coil Code	Connector Type
00	R00	No Coil
AJ		Amp Junior
AS	AS	AMP SuperSeal 1.5
DE	DE	Deutsch
FL	FL	Flying Leads
DN		DIN 43650

Housing

Code	Ports & Material	Housing Model Code
00	No housing	
S4S	#4 SAE, Steel	CP08-2-S4S
S6S	#6 SAE, Steel	CP08-2-S6S

* Aluminum bodies are to be used for pressures less than 210 bar [3000 psi].

* Additional housings available

Filter Option

F - Filter
Omit - No Filter

Seal Option

Code	Seal kit
B - Buna - N	11191986
V - Viton	11191987

Proportional Valves

PRV10-POC

Proportional Relief Valve, Spool Type, Pilot Operated, Normally Closed

250 bar [3600 psi] • 76 l/min [20 US gpm]

DESCRIPTION AND OPERATION

This is a pilot operated, spool type, normally closed, proportional relief valve. In the de-energized condition, the pressure setting will be at a maximum. As current is applied to the coil, the pressure setting of the valve will decrease proportionally. This valve is ideal for use in cooling circuits to regulate the speed of the fan.

SCHEMATIC

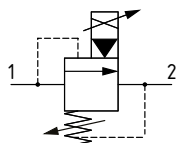

DIMENSIONS

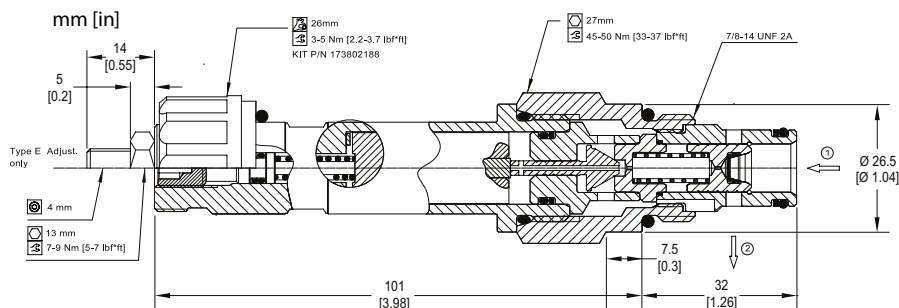

PERFORMANCE DATA

Rated pressure*	250 bar [3600 psi]
Rated flow	76 l/min [20 US gpm]
Recommended PWM frequency	200 Hz
Maximum Hysteresis	10%
Threshold current	0 A [12 VDC coil] 0 A [24 VDC coil]
Maximum control current	1.8 A [12 VDC coil] 0.9 A [24 VDC coil]
Coil Options	M19P
Weight	0.53 kg [1.17 lb]
Cavity	SDC10-2

*Rated pressure based on NFPA fatigue test standards (at 1 million cycles)

PERFORMANCE CURVES

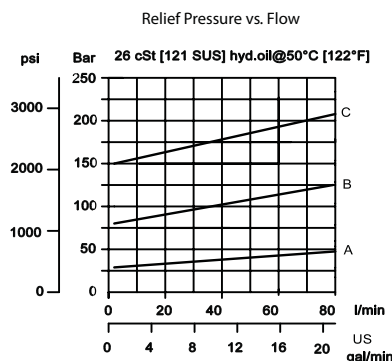
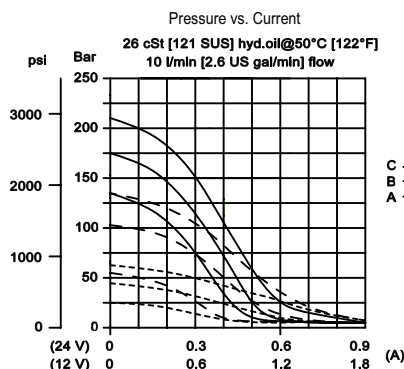

MODEL CODE

PRV10 - POC - 215 - C - 12D - DE - E - B - 00

Max Pressure Setting

Code - Pressure setting in bar (5 bar increments within specified Pressure Range)
Example:

Code	Bar	Psi
60	60	[870]

Pressure Range

Code	Pressure Range
A	25-65 bar [360-940 psi]
Standard Setting	55 bar [800 psi]
B	55-135 bar [800-1960 psi]
Standard Setting	135 bar [1960 psi]
C	135-215 bar [1960-3100 psi]
Standard Setting	215 bar [3100 psi]

Coil Voltage

00 - No coil, nut included*
12D - 12 VDC
24D - 24 VDC

*Standard Coil - Plastic coil nut and o-rings (p/n 173802188)

Connector Type

00 - No coil
AJ - AMP Junior
DE - Deutsch
DN - DIN 43650

Housing

Code	Ports & Material	Housing Model Code
00	No housing	
6S	AL, #6 SAE	CP10-2-6S
8S	AL, #8 SAE	CP10-2-8S
DG3B	AL, 3/8 BSP	SDC10-2-DG3B
DG4B	AL, 1/2 BSP	SDC10-2-DG4B

* Aluminum bodies are to be used for pressures less than 210 bar [3000 psi].
* Additional housings available

Seal Option

Code	Seal kit
B - Buna - N	354000719
V - Viton	354000819

Adjustment Option

E - External
F - Tamper resistant
H - Hidden

Proportional Valves

PRV12-POC

Proportional Relief Valve, Spool Type, Pilot Operated, Normally Closed

250 bar [3600 psi] • 180 l/min [47 US gpm]

DESCRIPTION AND OPERATION

This is a pilot operated, spool type, normally closed, proportional relief valve. In the de-energized condition, the pressure setting will be at a maximum. As current is applied to the coil, the pressure setting of the valve will decrease proportionally. This valve is ideal for use in cooling circuits to regulate the speed of the fan.

SCHEMATIC

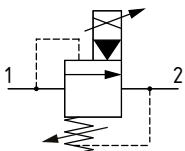

DIMENSIONS

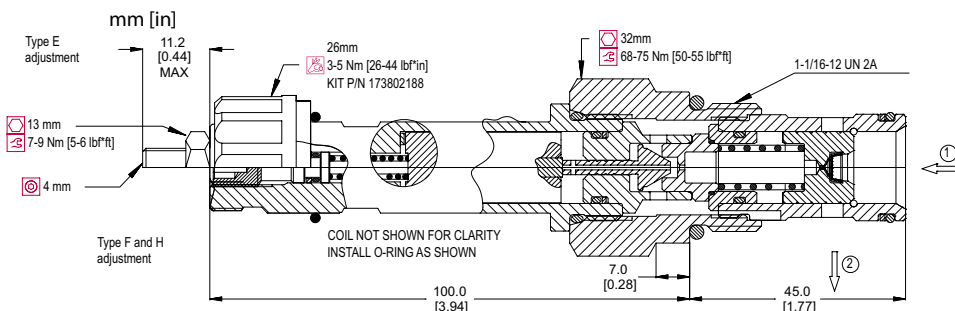

PERFORMANCE DATA

Rated pressure* 250 bar [3600 psi]

Rated flow 180 l/min [47 US gpm]

Recommended PWM frequency 200 Hz

Maximum Hysteresis 10%

Threshold current 0 A [12 VDC coil]

0 A [24 VDC coil]

Maximum control current 1.8 A [12 VDC coil]

0.9 A [24 VDC coil]

Coil Options M19P

Weight 0.62 kg [1.37 lb]

Cavity SDC12-2

*Rated pressure based on NFPA fatigue test standards (at 1 million cycles)

PERFORMANCE CURVES

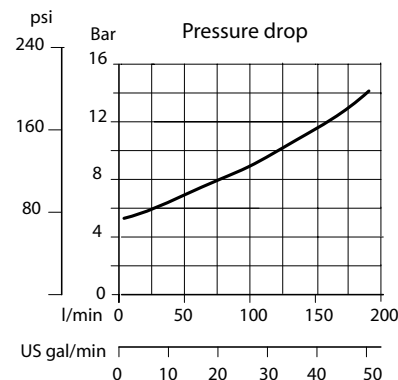
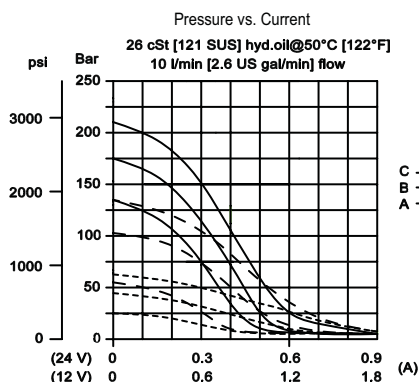

MODEL CODE

PRV12 - POC - 215 - C - 12D - DE - E - B - 00

Max Pressure Setting

Code - Pressure setting in bar (5 bar increments within specified Pressure Range)
Example:

Code	Bar	Psi
60	60	[870]

Pressure Range

Code	Pressure Range
A	25-65 bar [360-940 psi]
Standard Setting	55 bar [800 psi]
B	55-135 bar [800-1960 psi]
Standard Setting	135 bar [1960 psi]
C	135-215 bar [1960-3100 psi]
Standard Setting	215 bar [3100 psi]

Coil Voltage

00 - No coil, nut included*
12D - 12 VDC
24D - 24 VDC

*Standard Coil - Plastic coil nut and o-rings (p/n 173802188)

Connector Type

00 - No coil
AJ - AMP Junior
DE - Deutsch
DN - DIN 43650

Housing

Code	Ports & Material	Housing Model Code
00	No housing	
10S	AL, #10 SAE	CP12-2-10S
12S	AL, #12 SAE	CP12-2-12S
DG4B	AL, 1/2 BSP	SDC12-2-DG4B
DG6B	AL, 3/4 BSP	SDC12-2-DG6B

* Aluminum bodies are to be used for pressures less than 210 bar [3000 psi].
* Additional housings available

Seal Option

Code	Seal kit
B - Buna - N	354001319
V - Viton	354001819

Adjustment Option

E - External
F - Tamper resistant
H - Hidden

Proportional Valves

EPRV2-8

Proportional Pressure Reducing, Relieving, Direct Acting, Normally Open to Drain

35 bar [500 psi] • 7.6 l/min [2 US gpm]

DESCRIPTION AND OPERATION

This is a direct acting, proportional pressure reducing / relieving valve. In the de-energized condition, the inlet port 2 is blocked, while the reduced pressure in port 1 will be at the minimum setting and open to the tank port 3. By energizing the coil, the pressure in port 1 will increase proportionally to the current applied. Flow through port 2 to 1 is restricted to limit the pressure in port 1. In the case of over pressurization in port 1, the spool will open port 1 to port 3, which acts as a relief valve to limit the pressure in port 1.

SCHEMATIC

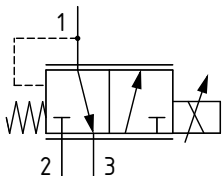

PERFORMANCE DATA

Rated pressure*	35 bar [500 psi]
Rated flow	7.6 l/min [2 US gpm]
Reduced pressure range	0-22 bar [0-320 psi]
Maximum Hysteresis	5%
Recommended PWM frequency	150 Hz
Maximum control current	0.85 A [12 VDC coil] 0.425 A [24 VDC coil]
Coil Options	S series
Weight	0.29 kg [0.64 lb]
Cavity	SDC08-3

*Rated pressure based on NFPA fatigue test standards (at 1 million cycles)

DIMENSIONS

mm [in]

Coil nut torque
5-8 Nm [4-6 ft lbs]

Installation torque
A - 34-41 Nm [25-30 ft lbs]

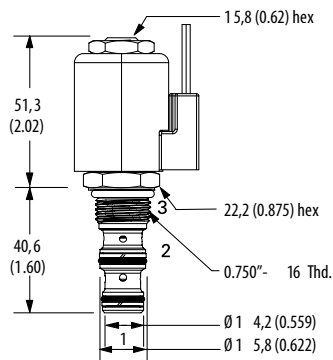

PERFORMANCE CURVES

Flo w - L/min (21,8 cSt oil @ 49°C)

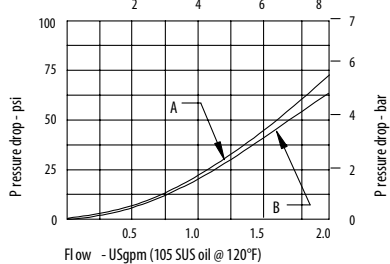

A - Port 1 to port 3 B - Port 2 to port 1

Flow - L/min (21,8 cSt oil @ 49°C)

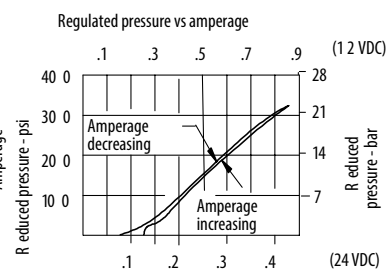
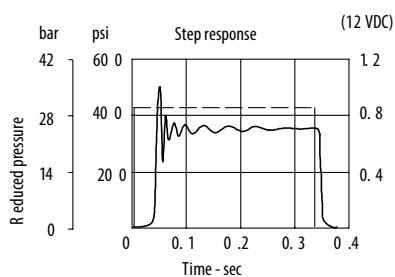
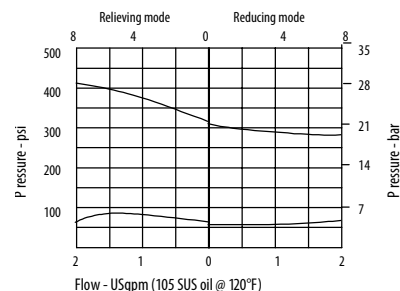

MODEL CODE

EPRV2 - 8 - V - A - 4T - 12D - G - S

Seal Option

Code	Seal kit	Housing Material
Omit	Buna - N 02-179451	Omit - No housing
V	Viton 02-179452	A - Aluminium

Housing

Code	Ports	Aluminium
0	No housing	
4T	#4 SAE	02-160741
6T	#6 SAE	02-160742
2G	1/4" BSP	02-160739
3G	3/8" BSP	02-160740

* Aluminium bodies are to be used for pressures less than 210 bar [3000 psi].

* Additional housings available

Coil series

Omit - No coil
S - S series coil

Connector Type

Omit - No coil
G - ISO 4400 DIN 43650
W - Flying lead
N - Deutsch (DC only)
Y - Amp JR (DC only)
D - Metripack 150 male (DC only)
J - Metripack 280 male (DC only)

Coil Voltage

00 - No coil, nut included (p/n 565558)
12D - 12 VDC
24D - 24 VDC

Proportional Valves

PPD22A

Proportional Pressure Reducing, Relieving, Direct Acting, Normally Open to Drain

210 bar [3000 psi] • 20 l/min [5.3 US gpm]

DESCRIPTION AND OPERATION

This is a direct acting, proportional pressure reducing / relieving valve. In the de-energized condition, the inlet port 2 is blocked, while the reduced pressure in port 1 will be at the minimum setting and open to the tank port 3. By energizing the coil, the pressure in port 1 will increase proportionally to the current applied. Flow through port 2 to 1 is restricted to limit the pressure in port 1. In the case of over pressurization in port 1, the spool will open port 1 to port 3, which acts as a relief valve to limit the pressure in port 1.

SCHEMATIC

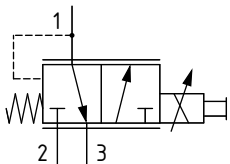

DIMENSIONS

mm [in]

Coil nut torque
3.4 Nm [2.5 ft lbs]

Installation torque
A - 30 Nm [22 lbs ft]

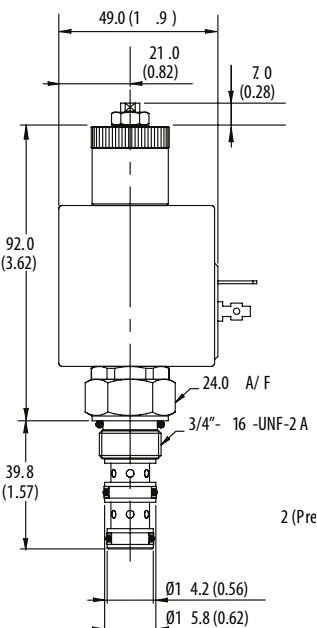

PERFORMANCE DATA

Rated pressure	210 bar [3000 psi]
Rated flow	20 l/min [5.3 US gpm]
Max reduced pressure	19W coil: 24 bar [350 psi] 29W coil: 28 bar [405 psi]
Leakage	50 ml/min @ 210 bar [3000 psi]
Recommended PWM frequency	200 Hz
Maximum Hysteresis	16% max without PWM
Threshold current	19% of max current
Coil Options	C16
Weight	0.25 kg [0.55 lb]
Cavity	A3531

PERFORMANCE CURVES

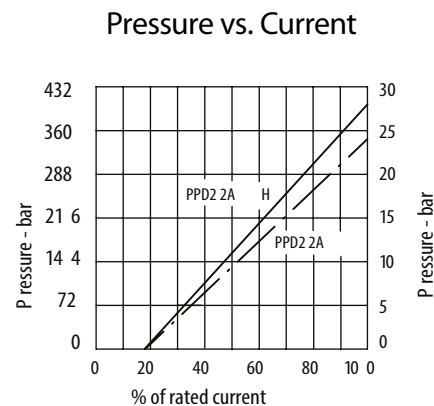
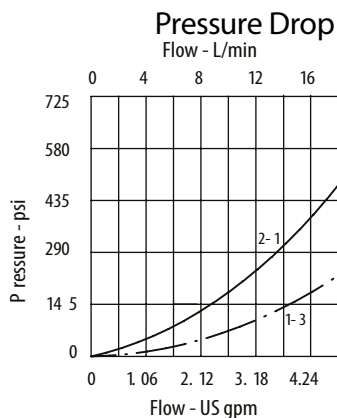

MODEL CODE

PPD22A - V - 6 - H - 12 - 3W

Seal Option

Code	Seal kit
N - Buna-N	SK1119
V - Viton	SK1119V

Manual Override Option

6 - Screw Type

Connector Type

Omit - No coil
H - DIN 43650
F - Flying Lead
DM - Deutsch moulded

Housing

Code	Ports	Aluminium
Omit	No housing	
2W	1/4" BSP	A7724
3W	3/8" BSP	A6684
6T	3/8" SAE	B6516

* Aluminium bodies are to be used for pressures less than 210 bar [3000 psi].

* Additional housings available

Coil Voltage

Omit - No coil
12 - 12 VDC
24 - 24 VDC

Proportional Valves

PPR09-POD

Proportional Pressure Reducing, Relieving, Pilot Operated, Normally Open to Drain

50 bar [725 psi] • 25 l/min [6.6 US gpm]

DESCRIPTION AND OPERATION

This is a pilot operated, proportional pressure reducing / relieving valve. In the de-energized condition, the inlet port 2 is blocked, while the reduced pressure in port 3 will be at the minimum setting and open to the tank port 4. By energizing the coil, the pressure in port 3 will increase proportionally to the current applied. Flow through port 2 to 3 is restricted to limit the pressure in port 3. In the case of over pressurization in port 3, the spool will open port 3 to port 4, which acts as a relief valve to limit the pressure in port 3. These valves are ideal for clutch control or as pilot valves for large directional control valves.

SCHEMATIC

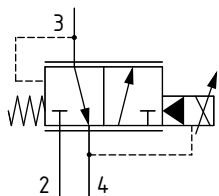

DIMENSIONS

mm [in]

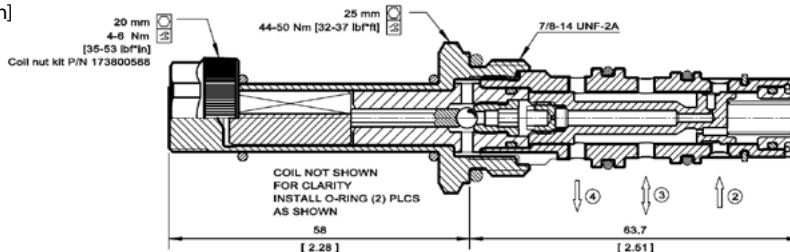

PERFORMANCE DATA

Rated pressure	50 bar [725 psi]
Rated flow @ 7 bar [100 psi]	25 l/min [6.6 US gpm]
Maximum Hysteresis	6%
Threshold current	0.15 A [12 VDC coil] 0.08 A [24 VDC coil]
Maximum control current	1.2 A [12 VDC coil] 0.6 A [24 VDC coil]
Coil Options	M13, R13
Weight	0.34 kg [0.75 lb]
Cavity	SDC10-4

PERFORMANCE CURVES

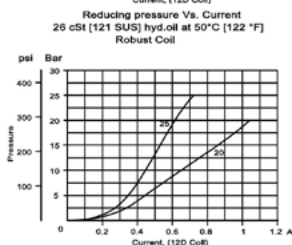
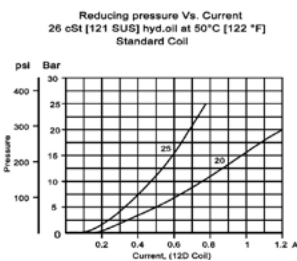
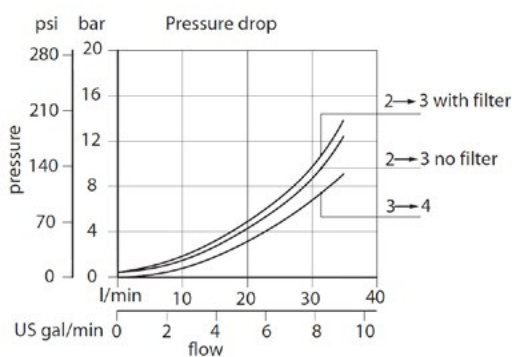

MODEL CODE

PPR09 - POD - 25 - 12D - DN - V - F - 00

Max Pressure Option

Code	Pressure Range
20	0-20 bar (0-290 psi)
25	0-25 bar (0-360 psi)

Coil Voltage

Standard Coil Code	Robust Coil Code	Coil Voltage
00	R00	No Coil, nut included*
12D	R12D	12 VDC
24D	R24D	24 VDC

*Standard Coil - Plastic coil nut and o-rings (p/n 173800588)

*Robust Coil - Steel coil nut and no o-rings (p/n 173800539)

Connector Type

Standard Coil Code	Robust Coil Code	Connector Type
00	R00	No Coil
AJ		Amp Junior
AS	AS	AMP SuperSeal 1.5
DE	DE	Deutsch
FL	FL	Flying Leads
DN		DIN 43650

Housing

Code	Ports & Material	Housing Model Code
00	No housing	
6S	AL, #6 SAE	CP10-4-6S
8S	AL, #8 SAE	CP10-4-8S
L3B	AL, 3/8 BSP	SDC10-4-L3B
L4B	AL, 1/2 BSP	SDC10-4-L4B

* Aluminum bodies are to be used for pressures less than 210 bar [3000 psi].

* Additional housings available

Filter Option

00 - No Filter
F - Filter, 300 um

Seal Option

Code	Seal kit
B - Buna - N	230000760
V - Viton	230001030

Proportional Valves

PPR09-POR

Proportional Pressure Reducing, Relieving, Pilot Operated

50 bar [725 psi] • 25 l/min [6.6 US gpm]

DESCRIPTION AND OPERATION

This is a pilot operated, proportional pressure reducing / relieving valve. In the de-energized condition, flow through port 2 to 3 is restricted to limit the pressure in port 3 at the maximum setting value. In the case of over pressurization in port 3, the spool will open port 3 to port 4, which acts as a relief valve to limit the pressure in port 3. By energizing the coil, the pressure in port 3 will decrease proportionally to the current applied. When fully energized, the inlet port 2 is blocked, while the reduced pressure in port 3 will be at the minimum setting and open to the tank port 4.

SCHEMATIC

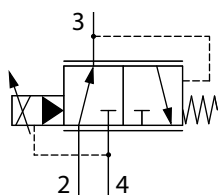

DIMENSIONS

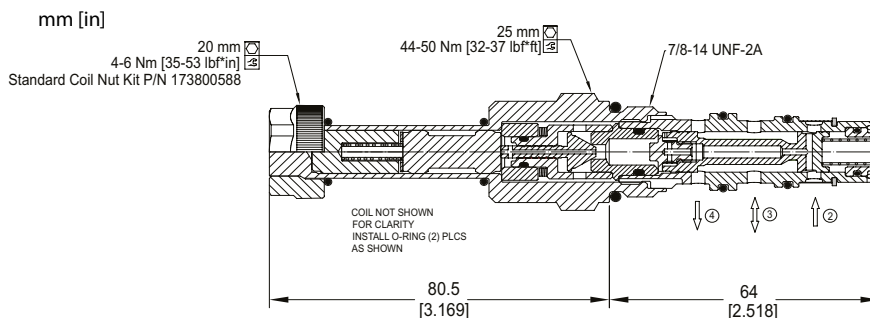

PERFORMANCE DATA

Rated pressure	50 bar [725 psi]
Rated flow @ 7 bar [100 psi]	25 l/min [6.6 US gpm]
Maximum Hysteresis	6%
Threshold current	0.15 A [12 VDC coil] 0.08 A [24 VDC coil]
Maximum control current	1.2 A [12 VDC coil] 0.6 A [24 VDC coil]
Coil Options	M13, R13
Weight	0.34 kg [0.75 lb]
Cavity	SDC10-4

PERFORMANCE CURVES

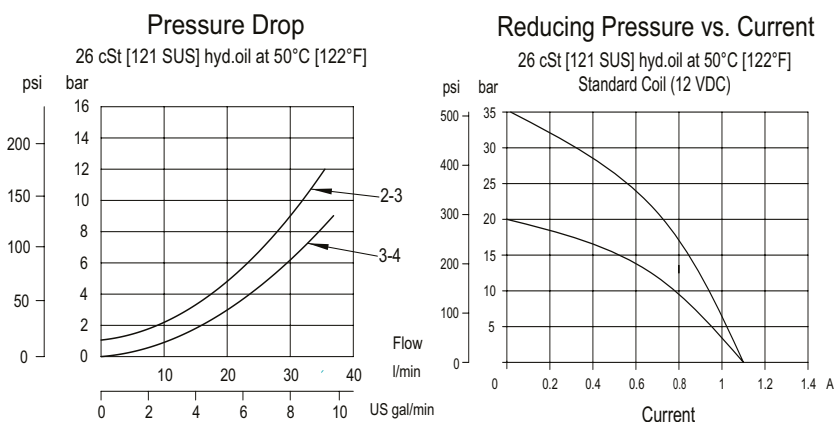

MODEL CODE

PPR09 - POR - 20 - 12D - DN - V - F - 00

Max Pressure Option

Code	Pressure Range
20	0-20 bar (0-290 psi)
35	0-35 bar (0-500 psi)

Coil Voltage

Standard Coil Code	Robust Coil Code	Coil Voltage
00	R00	No Coil, nut included*
12D	R12D	12 VDC
24D	R24D	24 VDC

*Standard Coil - Plastic coil nut and o-rings (p/n 173800588)

*Robust Coil - Steel coil nut and no o-rings (p/n 173800539)

Connector Type

Standard Coil Code	Robust Coil Code	Connector Type
00	R00	No Coil
AJ		Amp Junior
AS	AS	AMP SuperSeal 1.5
DE	DE	Deutsch
FL	FL	Flying Leads
DN		DIN 43650

Housing

Code	Ports & Material	Housing Model Code
00	No housing	
6S	AL, #6 SAE	CP10-4-6S
8S	AL, #8 SAE	CP10-4-8S
L3B	AL, 3/8 BSP	SDC10-4-L3B
L4B	AL, 1/2 BSP	SDC10-4-L4B

* Aluminum bodies are to be used for pressures less than 210 bar [3000 psi].

* Additional housings available

Filter Option

00 - No Filter
F - Filter, 300 um

Seal Option

Code	Seal kit
B - Buna - N	230000760
V - Viton	230001030

Proportional Valves

XRP 06

Proportional Pressure Reducing, Relieving, Pilot Operated

315 bar [4600 psi] • 25 l/min [6.6 US gpm]

DESCRIPTION AND OPERATION

This is a pilot operated, proportional pressure reducing / relieving valve. In the de-energized condition, the inlet port 2 is open to the reduced port 1, which will be at the minimum setting. By energizing the coil, the pressure in port 1 will increase proportionally to the current applied. Flow through port 2 to 1 is restricted to limit the pressure in port 1. In the case of over pressurization in port 1, the spool will open port 1 to port 3, which acts as a relief valve to limit the pressure in port 1.

SCHEMATIC

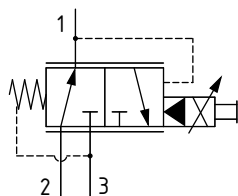

DIMENSIONS

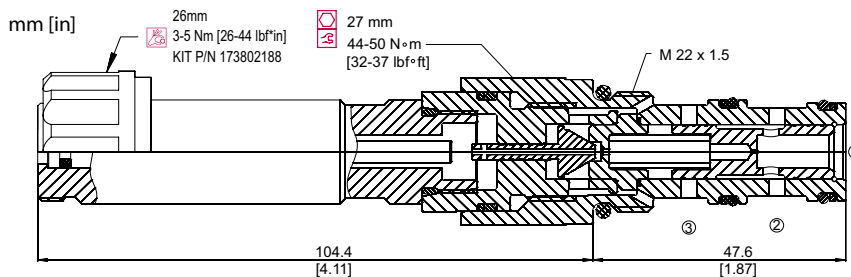

PERFORMANCE DATA

Rated pressure	315 bar [4600 psi]
Rated flow	25 l/min [6.6 US gpm]
Maximum Hysteresis	3%
Threshold current	0 A [12 VDC coil] 0 A [24 VDC coil]
Maximum control current	1.8 A [12 VDC coil] 0.9 A [24 VDC coil]
Coil Options	M19P
Weight	0.55 kg [1.21 lb]
Cavity	NCS 06/3

PERFORMANCE CURVES

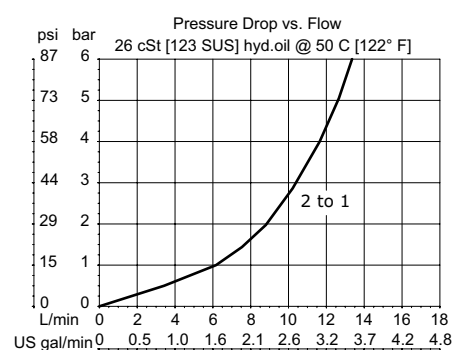
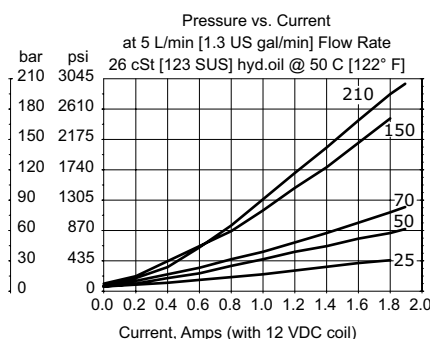

MODEL CODE

XRP 06 - 70 - 12D - DE - EN - 00 - V

Max Pressure Option

Code	Pressure Range
25	6-25 bar [90-360 psi]
50	6-55 bar [90-800 psi]
70	5-75 bar [90-1100 psi]
150	8-155 bar [120-2200 psi]
210	9-210 bar [130-3000 psi]

Coil Voltage

00 - No coil, nut included*
12D - 12 VDC
24D - 24 VDC

*Standard Coil - Plastic coil nut and o-rings (p/n 173802188)

Connector Type

00 - No connector
AJ - AMP Jr
DE - Deutsch
DN - DIN 43650 (ISO 4400)
FL - Lead wires

Seal Option

Code	Seal kit
V - Viton	230000110
Omit - Buna - N	230000070

Housing

Code	Ports & Material	Housing Model Code
00	No Housing	
SE6S	AL, #6 SAE	NCS06/3-SE-6S
SE8S	AL, #8 SAE	NCS06/3-SE-8S
SE3/8	AL, 3/8 BSP	NCS06/3-SE-3/8
SE1/2	AL, 1/2 BSP	NCS06/3-SE-1/2

* Aluminum bodies are to be used for pressures less than 210 bar [3000 psi].
* Additional housings available

Manual Override Option

00 - Push pin
EN - Screw Type

Proportional Valves

PPAR1-10

Proportional Pressure Reducing, Relieving, Pilot Operated

210 bar [3000 psi] • 30 l/min [8 US gpm]

DESCRIPTION AND OPERATION

This is a pilot operated, proportional pressure reducing / relieving valve. In the de-energized condition, the inlet port 2 is open to the reduced port 1, which will be at the minimum setting. By energizing the coil, the pressure in port 1 will increase proportionally to the current applied. Flow through port 2 to 1 is restricted to limit the pressure in port 1. In the case of over pressurization in port 1, the spool will open port 1 to port 3, which acts as a relief valve to limit the pressure in port 1.

SCHEMATIC

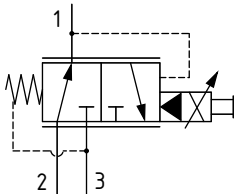

PERFORMANCE DATA

Rated pressure*	210 bar [3000 psi]
Rated flow	30 l/min [8 US gpm]
Pressure Range	7-210 bar [100-3000 psi]
Maximum hysteresis	5%
Maximum control current	2.0 A [12 VDC coil] 1.0 A [24 VDC coil]
Coil Options	J series
Weight	0.44 kg [0.98 lb]
Cavity	SDC10-3

*Rated pressure based on NFPA fatigue test standards (at 1 million cycles)

PERFORMANCE CURVES

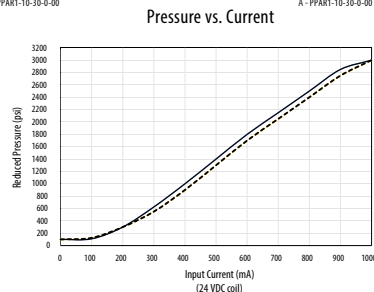
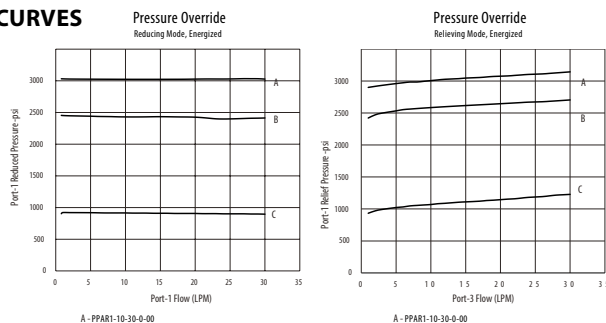

MODEL CODE

PPAR1 - 10 - V - 10 - S - 3B - 12D - G - J

Seal Option

Code	Seal kit
Omit - Buna - N	565804
V - Viton	889599

Max Pressure Setting

Code x 100 - Pressure setting in psi [100 psi increments within specified Pressure Range]
Pressure Range: 7-210 bar [100-3000 psi]
Example:

Code	Bar	Psi
05	35	[500 psi]
10	69	[1000 psi]

Manual Override Option

Omit - No manual override
S - Screw type

Coil series

Omit - No coil
J - J series, 23 W

Connector Type

Omit - No coil
G - DIN 43650
Q - Spade Terminals
W - Leadwire
N - Deutsch
Y - Amp JR

Coil Voltage

00 - No coil, nut included (p/n 565559)
12D - 12 VDC
24D - 24 VDC

Housing

Code	Ports	Aluminum heavy duty	Aluminum standard duty
0	No housing		
3B	3/8" BSP		02-173358
6T	#6 SAE		566162
2G	1/4" BSP	876702	
3G	3/8" BSP	876714	
6H	#6 SAE	876704	
8H	#8 SAE	876711	

* Aluminum bodies are to be used for pressures less than 210 bar [3000 psi].

* Additional housings available

DIMENSIONS

mm [in]

Coil nut torque
5-8 Nm [4-6 ft lbs]

Installation torque

A - 47-54 Nm [35-40 ft lbs]

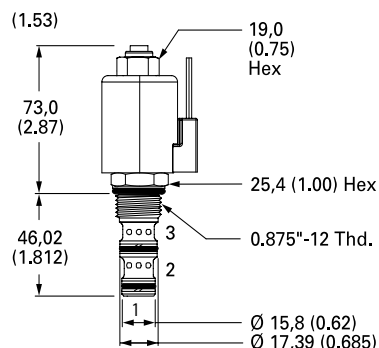

Proportional Valves

PPR10-PAC

Proportional Pressure Reducing, Relieving, Pilot Operated

250 bar [3600 psi] • 38 l/min [10 US gpm]

DESCRIPTION AND OPERATION

This is a pilot operated, proportional pressure reducing / relieving valve. In the de-energized condition, the inlet port 2 is open to the reduced port 1, which will be at the maximum setting. By energizing the coil, the pressure in port 1 will decrease proportionally to the current applied. Flow through port 2 to 1 is restricted to limit the pressure in port 1. In the case of over pressurization in port 1, the spool will open port 1 to port 3, which acts as a relief valve to limit the pressure in port 1.

SCHEMATIC

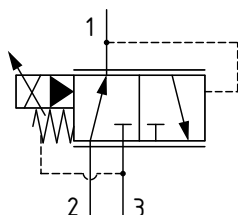

DIMENSIONS

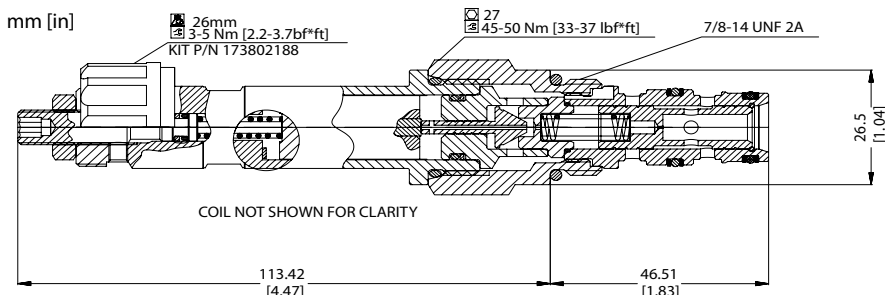

PERFORMANCE DATA

Rated pressure*	250 bar [3600 psi]
Rated flow	38 l/min [10 US gpm]
Maximum Hysteresis	10%
Threshold current	0 A [12 VDC coil] 0 A [24 VDC coil]
Maximum control current	1.4 A [12 VDC coil] 0.7 A [24 VDC coil]
Coil Options	M19P
Weight	0.62 kg [1.37 lb]
Cavity	SDC10-3

*Rated pressure based on NFPA fatigue test standards (at 1 million cycles)

PERFORMANCE CURVES

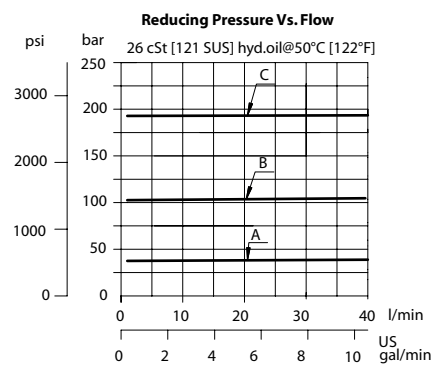
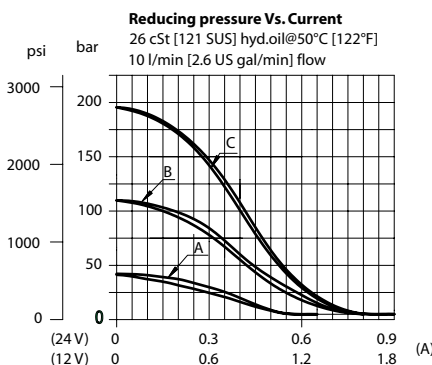

MODEL CODE

PPR10 - PAC - 40 - A - 12D - DN - B - 00

Max Pressure Setting

Code - Pressure setting in bar (5 bar increments within specified Pressure Range)
Example:

Code	Bar	Psi
60	60	[870]

Pressure Range

Code	Pressure Range
A*	20-60 bar [290-870 psi] Standard Setting 40 bar [580 psi]
B	70-150 bar [1015-2175 psi] Standard Setting 100 bar [1960 psi]
C	160-210 bar [2320-3000 psi] Standard Setting 200 bar [2900 psi]

*Max inlet pressure = 150 bar [2175 psi]

Coil Voltage

00 - No coil, nut included*
12D - 12 VDC
24D - 24 VDC

*Plastic coil nut and o-rings (p/n 173802188)

Housing

Code	Ports & Material	Housing Model Code
00	No housing	
6S	AL, #6 SAE	CP10-3-6S
8S	AL, #8 SAE	CP10-3-8S
SE3B	AL, 3/8" BSP	SDC10-3-SE3B
SE4B	AL, 1/2" BSP	SDC10-3-SE4B

* Aluminum bodies are to be used for pressures less than 210 bar [3000 psi].
* Additional housings available

Seal Option

Code	Seal kit
B - Buna - N	354004210
V - Viton	354003719

Connector Type

00 - No coil
AJ - AMP Jr
DE - Deutsch
DN - DIN 43650 (ISO 4400)
FL - Lead wires

Danfoss