



iC7-Automation EtherNet/IP

EtherNet/IP OS7IP



Contents

1 Introduction and Safety

1.1 Purpose of the Operating Guide	5
1.2 Additional Resources	5
1.3 Safety Symbols	5
1.4 Qualified Personnel	6
1.5 Safety Precautions	6
1.6 Abbreviations	7
1.7 Version History	8

2 Product Overview

2.1 EtherNet/IP Features and Technical Data	9
2.2 Communication Profiles and Objects	9
2.3 iC Speed	10
2.4 iC Motion	12
2.5 iC Active Front End	15
2.6 PROFIdrive Application Class 1	17
2.7 Network Topologies	20

3 Fieldbus Cable Connections

3.1 Prerequisites for Installation	24
3.2 Installation in Frequency Converters	24
3.3 Installation in System Modules	25
3.4 EMC-compliant Installation	26

4 Configuration

4.1 Selecting the Fieldbus Profile	28
4.2 Configuring the Ethernet Interface	28
4.3 Configuring Fieldbus Protection Settings for the Industry Application	29
4.4 Configuring Fieldbus Protection Settings for the Motion Application	30
4.5 Configuring Fieldbus Protection Settings for the Active Front End Application	32
4.6 Configuring EtherNet/IP Scanner	33
4.7 Configuring Rockwell Scanner	33
4.8 Configuring EtherNet/IP Connections	33

4.9 Reference Handling	35
4.9.1 Industry and Motion Applications	35
4.9.2 Active Front End Application	36
5 Troubleshooting	
5.1 Configuring Port Mirroring Settings	37
5.2 Identifying a Unit	37
5.3 Fieldbus Indicator LEDs	38
5.4 EtherNet/IP Report	40
6 EtherNet/IP Features	
6.1 Supported CIP Objects	41

1 Introduction and Safety

1.1 Purpose of the Operating Guide

This operating guide provides information about configuring the system, controlling the drive or power converter, accessing parameters, programming, troubleshooting, and some typical application examples.

The operating guide is intended for use by qualified personnel, who are familiar with the iC7 drives and power converters, EtherNet/IP technology, and the PC or PLC that is used as a master in the system.

Read the instructions before configuring EtherNet/IP, and follow the procedures in this guide.

1.2 Additional Resources

Additional resources are available to help understand the features, and safely install and operate the iC7 series products:

- Safety guides, which provide important safety information related to installing iC7 series drives and power converters.
- Installation guides, which cover the mechanical and electrical installation of drives, power converters, or functional extension options.
- Design guides, which provide technical information to understand the capabilities of the iC7 series drives or power converters for integration into motor control and monitoring systems.
- Operating guides, which include instructions for control options, and other components for the drive.
- Application guides, which provide instructions on setting up the drive or power converter for a specific end use. Application guides for application software packages also provide an overview of the parameters and value ranges for operating the drives or power converters, configuration examples with recommended parameter settings, and troubleshooting steps.
- *Facts Worth Knowing about AC Drives*, available for download on www.danfoss.com.
- Other supplemental publications, drawings, and guides are available at www.danfoss.com.

Latest versions of Danfoss product guides are available for download at <https://www.danfoss.com/en/service-and-support/documentation/>.

1.3 Safety Symbols

The following symbols are used in Danfoss documentation and products.



Indicates a hazardous situation which, if not avoided, will result in death or serious injury.



Indicates a hazardous situation which, if not avoided, could result in death or serious injury.



Indicates a hazardous situation which, if not avoided, could result in minor or moderate injury.



Indicates information considered important, but not hazard-related (for example, messages relating to property damage).

	ISO warning symbol for general warnings
	ISO warning symbol for hot surfaces and burn hazard
	ISO warning symbol for high voltage and electric shock
	Symbol for indicating the required discharge time of the capacitors in the product.
	ISO action symbol for referring to the instructions

1.4 Qualified Personnel

Correct and reliable transport, storage, installation, operation, and maintenance are required for the trouble-free and safe operation of the product. Only qualified personnel are allowed to install and operate this equipment.

Qualified personnel are defined as trained staff, who are authorized to install, commission, and maintain equipment, systems, and circuits in accordance with pertinent laws and regulations. Also, the qualified personnel must be familiar with the instructions and safety measures described in this guide.

1.5 Safety Precautions

DANGER



HIGH VOLTAGE

Drives and power converters contain high voltage when connected to AC mains input, DC supply, or load sharing. Failure to perform installation, startup, and maintenance by qualified personnel can result in death or serious injury.

- Only qualified personnel are allowed to perform installation, startup, and maintenance.

WARNING

UNINTENDED START

When the drive or power converter is connected to the AC mains or connected on the DC terminals, the motor may start at any time, causing risk of death, serious injury, and equipment or property damage.

- Stop the drive or power converter before configuring parameters.
- Make sure that the drive or power converter cannot be started by an external switch, a fieldbus command, an input reference signal from the control panel, or after a cleared fault condition.
- Disconnect the drive or power converter from the mains whenever safety considerations make it necessary to avoid an unintended motor start.
- Check that the drive or power converter and any driven equipment are in operational readiness.

WARNING

DISCHARGE TIME

The drive or power converter contains DC-link capacitors, which can remain charged even when the drive or power converter is not powered. High voltage can be present even when the warning indicator lights are off. Failure to wait the specified time after power has been removed before performing service or repair work can result in death or serious injury.

- Stop the motor.
- Disconnect all power sources, including permanent magnet type motors.
- Wait for capacitors to discharge fully. The discharge time is specified on the drive or power converter product label.
- Measure the voltage level to verify full discharge.

WARNING
LEAKAGE CURRENT HAZARD

Leakage currents exceed 3.5 mA. Failure to ground the drive or power converter properly can result in death or serious injury.

- Ensure that the minimum size of the ground conductor complies with the local safety regulations for high touch current equipment.

WARNING
EQUIPMENT HAZARD

Contact with rotating shafts and electrical equipment can result in death or serious injury.

- Ensure that only trained and qualified personnel perform installation, start-up, and maintenance.
- Ensure that electrical work conforms to national and local electrical regulations.
- Follow the procedures in this guide.

CAUTION
INTERNAL FAILURE HAZARD

An internal failure in the drive or power converter can result in serious injury when the drive or power converter is not properly closed.

- Ensure that all safety covers are in place and securely fastened before applying power.

1.6 Abbreviations

Table 1: Abbreviations

Abbreviation	Definition
ACD	Address Conflict Detection
CIP	Common Industrial Protocol
CTW	Control word
DHCP	Dynamic host configuration protocol
DLR	Device Level Ring
DNS	Domain Name Server

Table 1: Abbreviations - (continued)

Abbreviation	Definition
EMC	Electromagnetic compatibility
EO	Exclusive Owner
I/O	Input/Output
IO	Input Only
IP	Internet protocol
IRT	Isochronous real time
CP	Control panel
LED	Light-emitting diode
LO	Listen Only
MAV	Main Actual Value
MRV	Main Reference Value
MS	Module Status (LED)
PC	Personal computer
PLC	Programmable logic controller
REF	Reference
RPM	Revolution Per Minute
SNMP	Simple Network Management Protocol
STW	Status word
TCP	Transmission Control Protocol
UCMM	Unconnected Message Manager

1.7 Version History

This guide is regularly reviewed and updated. All suggestions for improvement are welcome.

The original language of this guide is English.

Table 2: Version History

Version	Remarks
AQ456329199699, version 0201	Updated to include the Active Front End application.
AQ456329199699, version 0101	First release.

2 Product Overview

2.1 EtherNet/IP Features and Technical Data

Fieldbus options for iC7 are integrated in the control board. Fieldbuses are enabled on communication interfaces X1 and X2 only. Modbus TCP is offered as standard, and other protocols such as PROFINET RT, and EtherNet/IP can be selected in the configurator when ordering a drive, or alternatively, they can be activated later by a proof-of-purchase token.

Table 3: EtherNet/IP Model Codes

Model code	Description
+BAIP	EtherNet/IP OS7IP

EtherNet/IP is an Ethernet-based automation standard that adapts the Common Industrial Protocol (CIP) to standard Ethernet technology. The EtherNet/IP and CIP technologies are managed by the ODVA organization.

The EtherNet/IP interface is designed to communicate with any system complying with the CIP EtherNet/IP standard. EtherNet/IP provides users with network tools to deploy standard Ethernet technology for manufacturing applications while enabling internet and enterprise connectivity.

Table 4: EtherNet/IP Features

Feature	Technical data
Minimum packet rate supported	1 ms
Connections	Class 1 I/O connection using TCP transport. The EtherNet/IP interface supports maximum 1 Class-1 connections, but several listen-only connections can be established if multicast is selected as the transport type.
	Class 3 Cyclic connection using UDP transport. Maximum 6 Class-3 connections are supported.
	UCMM Acyclic connection using TCP transport. This type of connection is used for explicit messaging.
Network management	DLR Device Level Ring Protocol for detecting and recovering from faults in ring-based networks.
	SNMP Simple Network Management Protocol

2.2 Communication Profiles and Objects

The iC7 series supports several communication profiles and mandatory objects. The supported profiles depend on the application software installed.

The fieldbus profile can be selected from the PLC configuration tool via a Profile Selector Assembly.

Communication profiles are selected in parameter *Fieldbus Profile* (1301).

Table 5: Communication Profiles and Supported Applications for iC7-Automation

Profile	Application software		
	Industry	Motion	Active Front End
iC Speed	X	X	–
iC Motion	–	X	–

Table 5: Communication Profiles and Supported Applications for iC7-Automation - (continued)

Profile	Application software		
	Industry	Motion	Active Front End
iC Active Front End	–	–	X
PROFIdrive Standard Telegram	X	X	–

2.3 iC Speed

2.3.1 Overview

The iC Speed profile is used with the iC7 series motor applications. The iC Speed profile differs from the PROFIdrive profile, because it does not have a state machine. It is only controlled by the actual state 1/0 of the control bits, not the sequence in which they are manipulated.

2.3.2 Control Word

Table 6: iC Speed Profile Control Word Bits

Bit number	Name	Description
0+1	Preset reference selector	00: Preset reference 1 01: Preset reference 2 10: Preset reference 3 11: Preset reference 4
2	Reserved	Reserved for future use. Any control words sent to the device should keep this bit at 0 to ensure compatibility with future extensions of the control word.
3	No coast/Coast	0: Causes the drive to immediately coast the motor. 1: No function.
4	No quick stop/Quick stop	0: Quick stops the drive and ramps down the motor speed to stop as defined with the quick stop ramp parameter. 1: No function.
5	No hold/Hold output frequency	0: Hold the present output frequency (in Hz). 1: No function.
6	Start/No start	0: Stops the drive and ramps down the motor speed as defined with the ramp-down parameter. 1: If the other starting conditions are fulfilled, this selection allows the drive to start the motor.
7	Reset	0: No function. 0 ⇒ 1: Reset faults. ⁽¹⁾
8	Jog/No jog	0: No function. 1: Sets the output frequency to the jog speed defined with the jog speed parameter.
9	Ramp select	0: Ramp 1 is active. 1: Ramp 2 is active.

Table 6: iC Speed Profile Control Word Bits - (continued)

Bit number	Name	Description
10	Data valid	0: Ignore the current process data. This is linked to the submodule where the CTW is present. If signals are to be covered, the CTW/STW profile (for example, the iC Speed profile) must be part of the signals list. 1: Use process data (controlled by PLC). Use the previously processed data when the data valid bit was true (no control by PLC).
11	Reserved	Reserved for future use.
12	User-defined	These bits are reserved for application-specific advanced control. Select the value <i>CTW bit x</i> for any input parameter to use this signal for the activation of a selected function. For more information, refer to the <i>Parameter Descriptions</i> chapter in the application guide.
13	User-defined	
14	User-defined	
15	User-defined	

1) Edge-triggered from 0 to 1 to reset the fault.

2.3.3 Status Word

Table 7: iC Speed Profile Status Word Bits

Bit number	Name	Description
0	Control ready	0 = The device controls are not ready and do not react to process data. 1 = The device controls are ready and react to process data.
1	Frequency converter ready	0 = The frequency converter is not ready for operation. This status does not involve faults and warnings as they are indicated in their respective bits elsewhere. 1 = The frequency converter is ready for operation.
2	Coast	0 = The frequency converter has an active coast signal and has released the motor. 1 = There are no active coast signals, and the motor can start when a start signal is given.
3	Fault	0 = There are no faults. 1 = A fault has occurred, and an acknowledge signal is required to re-establish operation.
4	Reserved	Reserved.
5	Reserved	Reserved.
6	Reserved	Reserved.
7	Warning	0 = There are no warnings. 1 = A warning is active.
8	Speed=reference	0 = The motor runs, but the current speed is different from the current speed reference, for example, while the speed ramps up or down during start or stop. 1 = The current motor speed matches the current speed reference within a given tolerance. The tolerance is product-specific.

Table 7: iC Speed Profile Status Word Bits - (continued)

Bit number	Name	Description
9	Bus control/Local operation	0 = The device does not react on commands from the fieldbus, for 1 of the following reasons: <ul style="list-style-type: none"> • CTW bit 10 = 0. • HMI is in local mode. • MyDrive® Insight has taken control. • Control places do not include fieldbus. 1 = The device is controlled and reacting to I/O and process data.
10	Frequency limit	0 = The output frequency has exceeded the defined motor limits. 1 = The output frequency is within the defined motor limits. The speed limits are set with the parameters in parameter group 5.8.3 Speed Limits and Monitors .
11	Operation	0 = There are no active start requests, and the process does not run. The motor is coasted and is not started. 1 = The process is running, and the motor can be running or start at any time.
12	Reserved	Reserved.
13	Reserved	Reserved.
14	User-defined	These bits are reserved for application-specific advanced control. For more information, refer to the <i>Parameter Descriptions</i> chapter in the application guide.
15	User-defined	

2.4 iC Motion

2.4.1 Overview

The iC Motion profile is used with the motion features of iC7-Automation and consists of:

- Motion-specific control word, speed reference, and position reference for controlling the drive.
- Motion-specific status word, actual speed, and actual position as status.

Table 8: Telegram Layout

	Word 1	Word 2	Word 3 and 4
Input to drive	Control word	Speed reference	Position reference
Output from drive	Status word	Actual speed	Actual position

Fieldbus reference is the default selection as the source for speed and position reference in the **5.5 Control Places** parameters but the references can be ignored if the **Control Places** settings are modified.

2.4.2 iC Motion Profile Control and Status Words

The iC Motion profile control and status words are based on the iC speed profile, with the addition of the most used signals for positioning and synchronizing. The Motion-specific signals require the selection of the appropriate operating mode, see parameter **5.4.2.16 Operation Mode**.

Table 9: Control Word

Bit	Name	Description
0	Preset position reference Bit 0	000 = Preset Position Ref. 1
1	Preset position reference Bit 1	001 = Preset Position Ref. 2
2	Preset position reference Bit 2	010 = Preset Position Ref. 3 011 = Preset Position Ref. 4 100 = Preset Position Ref. 5 101 = Preset Position Ref. 6 110 = Preset Position Ref. 7 111 = Preset Position Ref. 8
3	No Coast	0: Causes the drive to immediately coast the motor. 1: No function.
4	Start Synchronizing	0 = Ramp down to standstill. 1 = Follower locked to synchronizing master.
5	Enable Reference	0 = No Function. 1 = New position reference enabled.
6	Start	0 = Stop the frequency converter and ramp down the motor speed as defined with the ramp down parameter. 1 = If the other starting conditions are fulfilled, this selection allows the frequency converter to start the motor.
7	Reset	0: No function. 0 ⇒ 1: Acknowledge faults. ⁽¹⁾
8	Enable Superimposed	0 = No function. 1 = Execute superimposed movement.
9	Relative Positioning	0 = Absolute positioning. 1 = Relative positioning.
10	Data Valid	0 = Ignore the current process data. This is linked to the submodule where the CTW is present. If signals are to be covered, the CTW/STW profile (the iC Speed Profile for example) must be part of the signals list. 1 = Use process data (control by PLC). Use the previously processed data when the data valid bit was true (no control by PLC).
11	Enable Home	0 = Abort homing function. 1 = Execute homing function.
12	User-defined	These bits are reserved for application-specific advanced control. For more information, refer to the <i>Parameter Descriptions</i> chapter in the application guide.
13	User-defined	
14	User-defined	
15	User-defined	

1) Acknowledge is edge-triggered, when the logic is changed from 0 to 1. Faults can only be acknowledged if the triggering condition has been removed and any required acknowledgment has been done.

The basic commands such as **Start** and **Coast** are configured via **5.5 Control Places**. By default, the commands are mapped to the corresponding control word bits, but that can change if the **Control Places** settings are modified. The Motion-specific commands are not available for configuration in **Control Places**, but the logic when mapping these signals to digital inputs is "OR".

Table 10: Status Word

Bit	Name	Description
0	Control Ready	0 = The device controls are not ready and do not react to process data. 1 = The device controls are ready and react to process data.
1	Drive Ready	0 = The device is not ready for operation. This status does not involve faults and warnings as they are indicated in their respective bits elsewhere. 1 = The device is ready for operation.
2	No coast (Enabled)	0 = The frequency converter has an active coast signal and has released the motor. 1 = There are no active coast signals, and the motor can start when a start signal is given.
3	Fault	0 = There are no faults. 1 = A fault has occurred, and an acknowledge signal is required to re-establish operation.
4	Home Done	0 = Homing is not completed. 1 = Homing is completed.
5	In Sync	0 = Follower is not in sync with master. 1 = Follower is in sync with master within the tolerance specified by parameter 5.15.2.2 Synchronization Window .
6	Reserved	Reserved.
7	Warning	0 = There are no warnings. 1 = A warning is active.
8	Position error within tolerance	0 = Position error is greater than the tolerance specified by parameter 5.13.5.1 Position Error Window . 1 = Position error is within the tolerance specified by parameter 5.13.5.1 Position Error Window .
9	Bus control	0 = The device does not react on commands from the fieldbus, for 1 of the following reasons: <ul style="list-style-type: none"> • CTW bit 10 = 0. • HMI is in local mode. • MyDrive® Insight has taken control. • Control places do not include fieldbus. 1 = The device is controlled and reacting to I/O and process data.
10	Frequency limit OK	0 = The output frequency has exceeded the defined motor limits. 1 = The output frequency is within the defined motor limits. The speed limits are set with the parameters: <ul style="list-style-type: none"> • 5.8.3.1 Positive Speed Limit • 5.8.3.2 Negative Speed Limit • 5.8.3.3 Minimum Speed Limit
11	In operation	0 = There are no active start requests, and the process does not run. The motor is coasted and is not started. 1 = The process is running, and the motor can be running or start at any time.

Table 10: Status Word - (continued)

Bit	Name	Description
12	Target position reached	0 = Target position is not reached. 1 = Target position is reached within the window defined by parameter 5.14.2.18 On-target Window around the position reference.
13	Superimposed target reached	0 = Superimposed movement is not completed. 1 = Superimposed movement is completed.
14	User-defined	These bits are reserved for application-specific advanced control. For more information, refer to the <i>Parameter Descriptions</i> chapter in the application guide.
15	User-defined	

2.4.3 Speed Reference and Actual Speed

The speed values are represented by the N2 format, a 16-bit normalized value defined in the PROFIdrive profile. They are represented in percent of nominal motor speed.

PROFIdrive profile definition of N2

N2 is a linear normalized value. 0% corresponds to 0 (0x0), 100% corresponds to 2^{14} (0x4000).

Table 11: Range of N2 values

Coding	Data type	Range of values	Resolution	Length
113	N2	$-200\% \leq I \leq (200 - 2^{-14})\%$	$2^{-14} = 0.0061\%$	2 Octet

Coding:

- Representation in twos complement, the most significant bit (MSB) is the bit after the sign bit (SN) of the 1st octet.
- SN = 0: positive numbers including 0.
- SN = 1: negative numbers.

2.4.4 Position Reference and Actual Position

Position values are expressed in 32-bit signed position units. The units are scaled by parameters **5.13.4.4 Position Unit Numerator** and **5.13.4.5 Position Unit Denominator**.

2.5 iC Active Front End

2.5.1 Overview

The iC Active Front End profile is used in the iC7 series with the Active Front End application.

2.5.2 Control Word

Table 12: iC Active Front End Profile Control Word Bits

Bit number	Name	Description
0	Switch On Enabled	0: DC-link pre-charging, MCB closure, and running are prevented/interrupted. MCB is opened if closed. 1: DC-link pre-charging, MCB closure, and running are not prevented/interrupted. MCB is not opened if closed.
1	MCB Close Enabled	0: If pre-charging is completed, the MCB is not allowed to close. Running is also prevented or interrupted. MCB is opened if closed. 1: If pre-charging is completed, the MCB is allowed to close.
2	Quick Stop Inverse	0: Initiate quick stop. 1: Do not initiate quick stop.
3	Start	0: Stop the unit if it is running, or stop the pre-charging sequence if it is not completed. 1: Start running if already precharged. Otherwise initiate pre-charging and then start running. Use the parameter <i>Fieldbus Start Mode</i> (5114) to configure whether a new start command is required after the unit has been stopped, or whether the unit starts running immediately after all stopping conditions (quick stop, faults, and so on) are cleared.
4	Pre-charge	0: Stop the DC-link pre-charging, if ongoing. 1: Start/continue the DC-link pre-charging. Only used when the DC-link pre-charging is not controlled externally.
5	–	Reserved
6	–	Reserved
7	Fault Reset	0: Do not reset faults. 1: Reset active faults. A rising edge (a transition from false to true) on this bit issues a fault reset request.
8	–	Reserved
9	–	Reserved
10	Data Valid	0: Ignore the current incoming process data values, instead use the last processed value when <i>Data Valid</i> bit was true. 1: Use the current incoming process data values.
11	Watchdog	Incoming fieldbus watchdog bit. used for monitoring the fieldbus connection.
12	User-defined	These bits are reserved for application-specific advanced control. Select the value <i>CTW bit x</i> for any input parameter to use this signal for the activation of a selected function. For more information, refer to the <i>Parameter Descriptions</i> chapter in the application guide.
13	User-defined	
14	User-defined	
15	User-defined	

2.5.3 Status Word

Table 13: iC Active Front End Profile Status Word Bits

Bit number	Name	Description
0	Ready to Switch On	0: The unit is not ready to run. 1: The unit is ready to run. This bit indicates that the unit is ready to start the startup sequence, that is, pre-charging and/or MCB closure, if controlled by the application. There are no active faults and the Switch on Enabled bit is active.
1	Converter Ready	0: The unit is not ready to run. 1: The unit is ready to run. When this bit is true, it indicates that the unit can be successfully started with the Start bit (bit 3) of the control word.
2	Running	0: The unit is not running (modulating). 1: The unit is running (modulating).
3	Fault	0: No faults active. 1: One or more faults active.
4	--	Reserved
5	Quick Stop Inverse	0: Quick stop is active. 1: Quick stop not active.
6	--	Reserved
7	Warning	0: No active warnings. 1: One or more warnings are active.
8	--	Reserved
9	Control by PLC	0: Fieldbus is not the active control place. 1: Fieldbus is the active control place.
10	--	Reserved
11	Run Enabled	0: Run enable from a dedicated input signal is missing. 1: Run enable from a dedicated input signal is present. This bit indicates the state of parameter <i>Run Enable Input</i> (103)
12	--	Reserved
13	--	Reserved
14	--	Reserved
15	Watchdog	Outgoing fieldbus watchdog bit, mirroring control word bit Watchdog (bit 11).

2.6 PROFIdrive Application Class 1

2.6.1 Overview

Standard telegram 1 is implemented according to PROFIdrive Application Class 1 profile as defined in the PROFIdrive standard and state machine diagram. It can be used with iC7 series motor applications.

2.6.2 Control Word

Table 14: Control Word Bits in PROFIdrive Standard Telegram 1

Bit number	Name	Description
0	On-Off	0: Off. 1: On.
1	Coast stop	0: Coast stop. 1: No coast stop.
2	Quick stop	0: Quick stop. 1: No quick stop.
3	Operation	0: Disable operation. 1: Enable operation.
4	Ramp generator	0: Reset ramp generator. The output of the RFG is set to 0. The drive decelerates along the current limit or along the voltage limit of the DC link. 1: Enable ramp generator (RFG).
5	Freeze	0: Freeze ramp generator. Freezes the present output frequency (in Hz). 1: Unfreeze ramp generator.
6	Enable setpoint	0: Disable setpoint. 1: Enable setpoint.
7	Fault acknowledge	0: No function. 0 ⇒ 1: Acknowledge faults. ⁽¹⁾
8	Jog 1	0: Jog 1 off. 1: Jog 1 on. Operation is enabled, drive is at standstill, and STW1 bit 4, 5, 6: 0. The drive runs up along the ramp to jogging setpoint 1.
9	Jog 2	0: Jog 2 off. 1: Jog 2 on. Operation is enabled, drive is at standstill, and STW1 bit 4, 5, 6: 0. The drive runs up along the ramp to jogging setpoint 2.
10	Control by PLC	0: Ignores the current process data. This is linked to a submodule where the CTW is present. If signals are to be covered, the CTW/STW profile (for example, the iC Speed Profile) must be part of the signals list. 1: Uses process data (controlled by PLC).
11	–	Reserved
12	User-defined	These bits are reserved for application-specific advanced control. For more information, refer to the <i>Parameter Descriptions</i> chapter in the application guide.
13	User-defined	
14	User-defined	
15	User-defined	

¹⁾ Acknowledging is edge-triggered, when changing from logic 0 to logic 1.

2.6.3 Status Word

Table 15: Status Word Bits in PROFIdrive Standard Telegram 1

Bit number	Name	Description
0	Ready to switch on	0: Not ready to switch on. 1: Ready to switch on.
1	Ready to operate	0: Not ready to operate. 1: Ready to operate.
2	Operation enabled	0: Operation disabled. 1: Operation enabled.
3	Operation fault	0: No fault. 1: Fault present.
4	Coast stop	0: Coast stop activated (OFF2). 1: Coast stop not activated (No OFF2).
5	Quick stop	0: Quick stop activated (OFF3). 1: Quick stop not activated (No OFF3).
6	Switching on inhibited	0: Switching on not inhibited. 1: Switching on inhibited.
7	Warning	0: There are no warnings. 1: A warning has occurred.
8	Speed error within/out of tolerance range	0: The motor runs, but the present speed is more than 1% different from the reference. It could, for example, be the case while the speed ramps up/down during start/stop. 1: The present motor speed matches the present speed reference within 1% of motor nominal speed.
9	Fieldbus control active/inactive	0: The device does not react on commands from fieldbus. ⁽¹⁾ 1: The device is controlled and reacting to I/O and process data.
10	Speed reached/Speed not reached	0: The actual speed is below the comparison value set with parameter Limit Supervision 1 Threshold (5253). 1: The actual speed is above the comparison value set with parameter Limit Supervision 1 Threshold (5253).
11	Reserved	Reserved
12	Reserved	Reserved
13	Reserved	Reserved
14	Reserved	Reserved
15	Reserved	Reserved

1) The reason why the device does not react to commands can be:

- Fieldbus is not the active control place.
- Fieldbus signals are not configured to be part of the Advanced Control Place.

2.6.4 PROFIdrive State Machine

In the PROFIdrive control profile, the control bits perform different functions:

- 0–3 perform the basic startup and power-down functions.
- 4–10 perform application-oriented control.

- 12–15 can be configured for different purposes.

See [Figure 1](#) for the basic state transition diagram, where control bits 0–3 control the transitions and the corresponding status bit indicates the actual state. The black dots indicate the priority of the control signals. Fewer dots indicate lower priority, and more dots indicate higher priority.

The general state diagram is defined in the PROFIdrive standard.

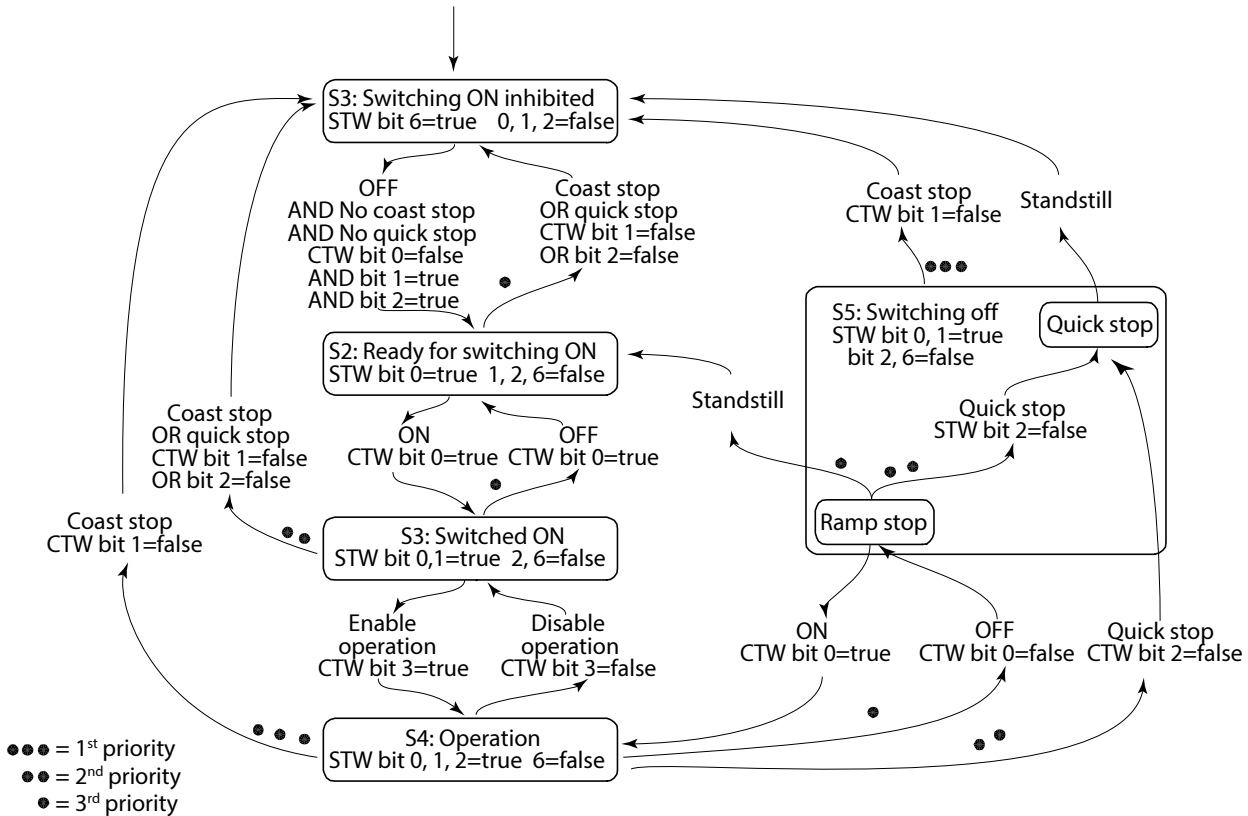

Figure 1: General State Diagram

2.7 Network Topologies

2.7.1 Overview

Communication interface X1/X2 is used for fieldbus connection.

The communication interface in the iC7 drives and power converters has 2 Ethernet ports (X1 and X2) and an embedded switch with 2 Ethernet RJ45 connectors. It has 1 MAC and IP address, and is considered a single device in the network. The communication interface supports 3 network topologies:

- Line topology
- Star topology
- Ring topology

2.7.2 Line Topology

In many applications, line topology enables simpler cabling and the use of fewer Ethernet switches. Observe network performance and the number of devices in a line topology. Too many devices in a line may exceed network update time limits.

NOTICE

When line topology is used, take precautions to avoid timeout in the PLC when more than 8 drives or power converters are installed in series. Each drive or power converter in the network adds a small delay to the communication due to the built-in Ethernet switch. When the update time is too short, the delay can lead to a timeout in the PLC.

- Set the update time as shown in the table. The numbers given are typical values and can vary from installation to installation.

Number of units connected in series	Minimum update time [ms]
<8	2
8–16	4
16–32	8
33–50	16
>50	Not recommended



NOTE: Using tools such as MyDrive® Insight may influence system performance in a line topology.

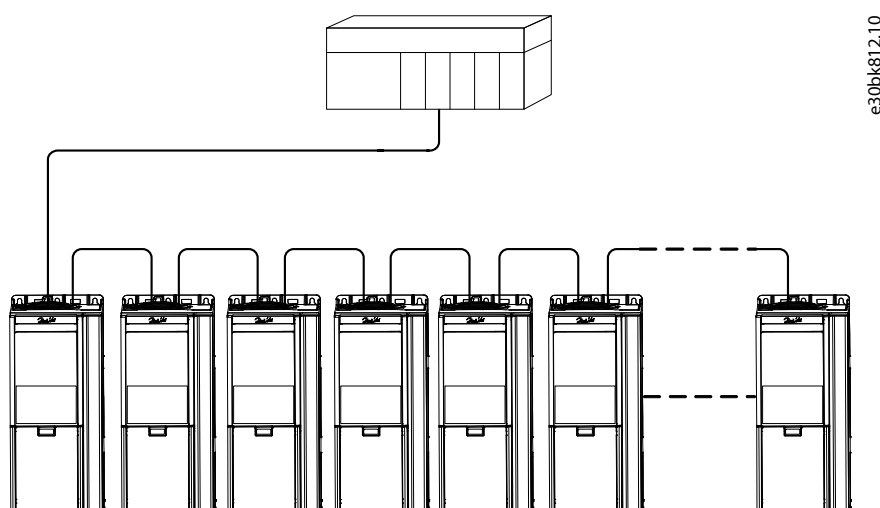

Figure 2: Example of Line Topology

NOTICE

Installing drives or power converters of different current ratings in line topology may result in unwanted fieldbus timeout messages in the event log.

- Mount the drives or power converters with the longest discharge time first in the line topology. In normal operation, the drives or power converters with bigger current ratings have a longer discharge time.

2.7.3 Star Topology

In a star network, all devices are connected to the same switch or switches. Star topology reduces the damage caused by a single cable failure. In a star topology, a single cable failure affects a single device instead of all devices in the network. In many applications, this topology enables simpler cabling depending on the location and distance of the device.

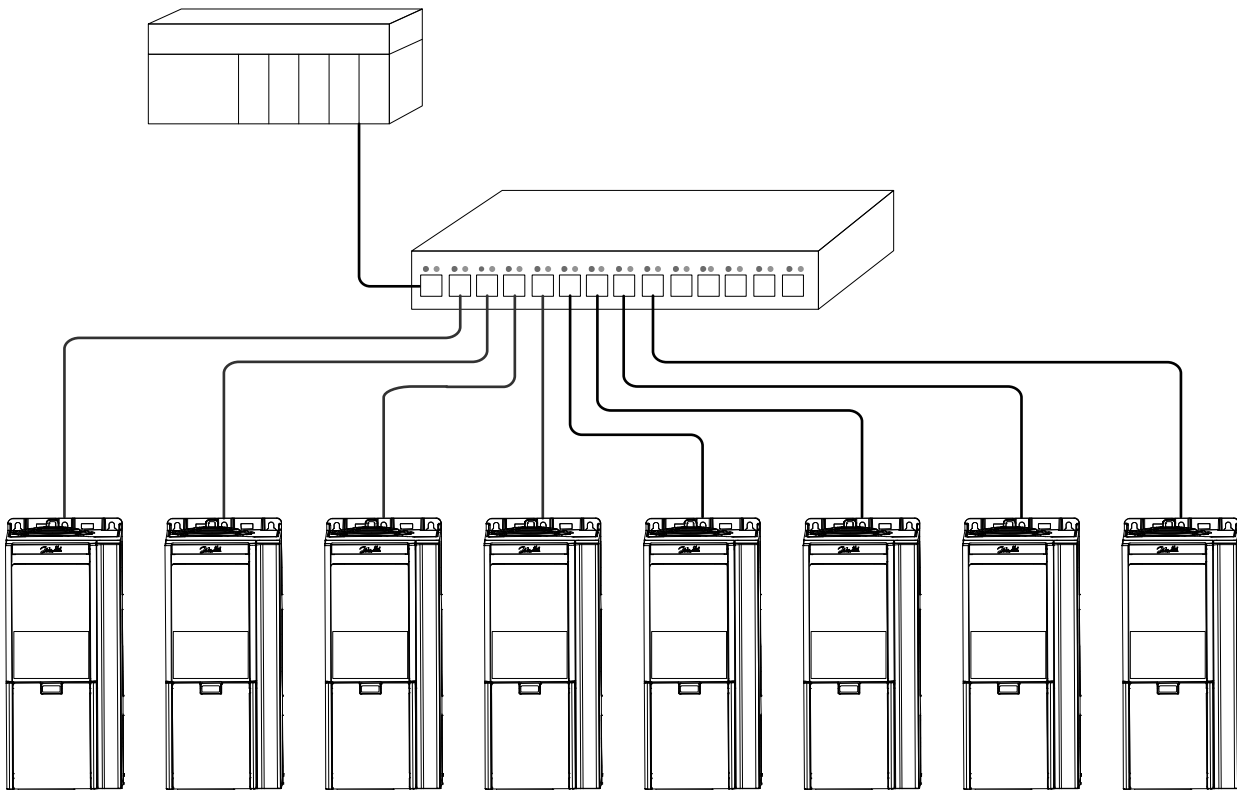

Figure 3: Example of Star Topology

2.7.4 Ring Topology

Ring topology enables the same simpler cabling and reduced cabling costs as line topology, but also reduces the damage caused by a single cable failure in a similar manner as star topology.

NOTICE

When ring topology is used, take precautions to avoid timeout in the PLC when more than 8 drives or power converters are installed in series. Each drive or power converter in the network adds a small delay to the communication due to the built-in Ethernet switch. When the update time is too short, the delay can lead to a timeout in the PLC.

- Set the update time as shown in the table. The numbers given are typical values and can vary from installation to installation.

Number of units connected in series	Minimum update time [ms]
<8	2
8–16	4
16–32	8
33–50	16
>50	Not recommended

The ring topology protocol depends on the protocol in use.

For EtherNet/IP, the device level ring (DLR) is used. A DLR network consists of an active ring supervisor and any number of ring nodes. The iC7 drive acts as a ring node with its 2 Ethernet ports X1/X2. The ring supervisor is typically a PLC and it is responsible for generating a beacon at regular intervals. The DLR protocol contains several fault detection and ring recovery mechanisms. The ring supervisor can block traffic on 1 port to avoid loops, faults are detected when beacon traffic is interrupted, and/or link/ node failure is detected by adjacent nodes. Any DLR-related settings are handled via the ring supervisor.

! IMPORTANT: Do not use non-DLR compliant devices throughout the DLR domain.

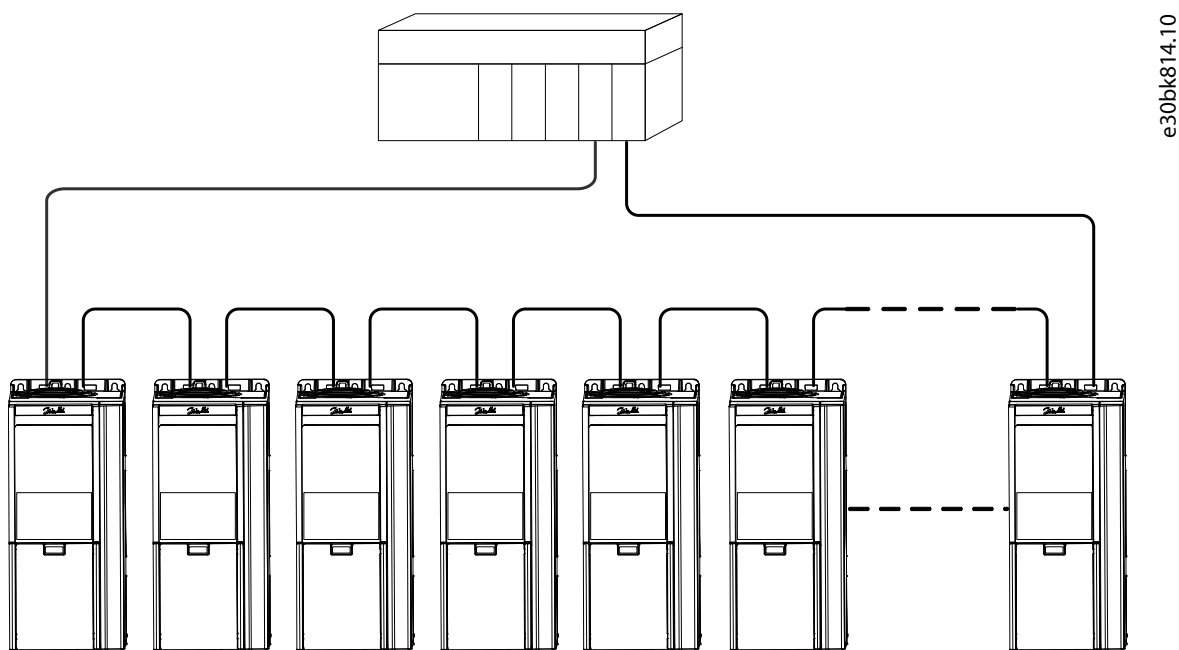

Figure 4: Example of Ring Topology

3 Fieldbus Cable Connections

3.1 Prerequisites for Installation

Communication interfaces are integrated in the control board in iC7 drives and power converters.

The position of the connections differs based on the control board concept and frame, for example. For more information on the location of the connections, cabling, and shielding, refer to the product-specific design guide.

3.2 Installation in Frequency Converters

3.2.1 Communication Interface X1/X2 in Frames FA02–FA12

The communication interface is on the top of the frequency converter as shown in [Figure 5](#). Industrial-grade RJ45 connectors are recommended for optimal connection. A combined shield/fixing plate, the Fieldbus EMC plate, is available as an accessory to strengthen the mechanical fixation of the cables. For information on ordering the EMC plate, refer to the product-specific design guide.

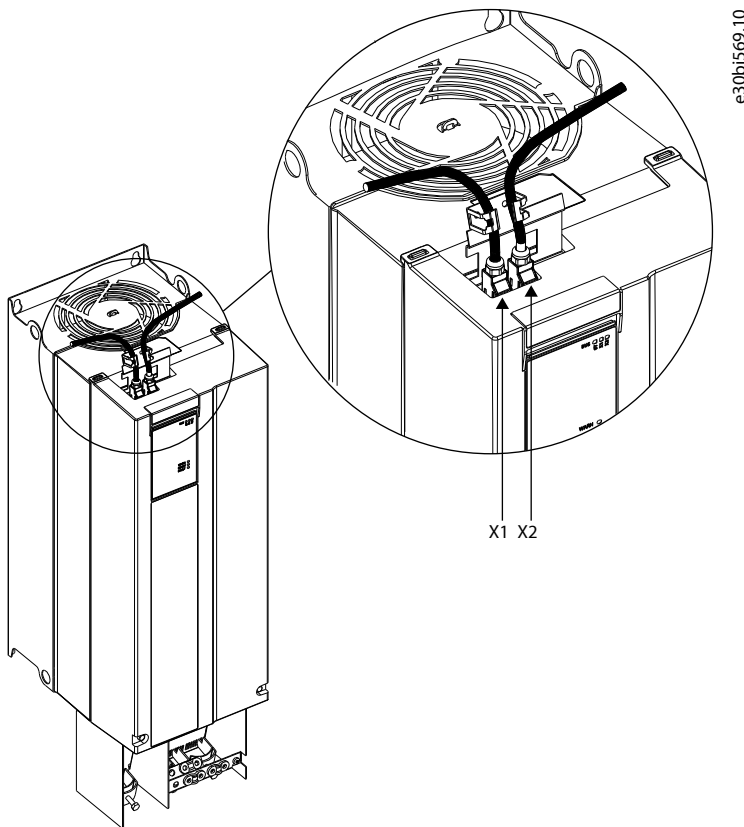

Figure 5: Location of the Communication Interface, X1/X2 in FA02-FA12 Frames (with the Optional EMC Plate)

3.2.2 Communication Interface X1/X2 in Frames FB09–FB12/FK06–FK12

The communication interface ports are located inside the frequency converter. The position of the ports and the recommended wiring path are shown in [Figure 6](#) and [Figure 7](#).

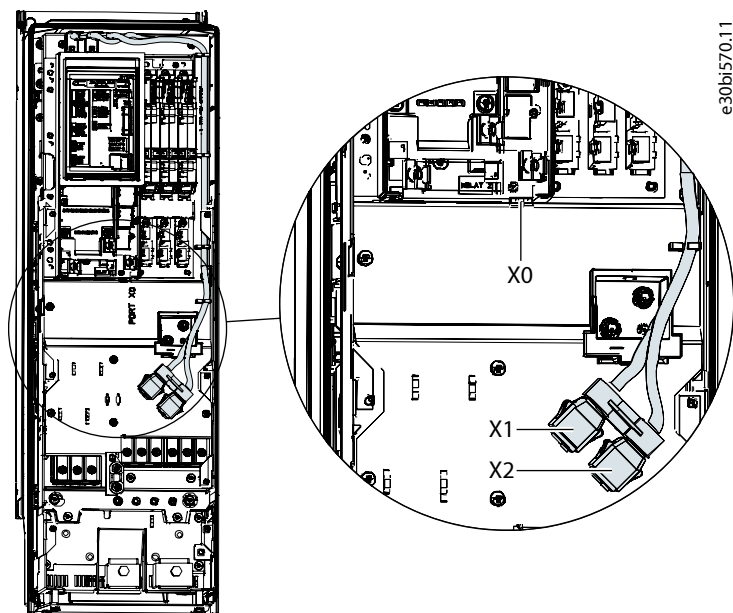

Figure 6: Communication Port X0, X1, and X2 Locations in FK06–FK08 Frames

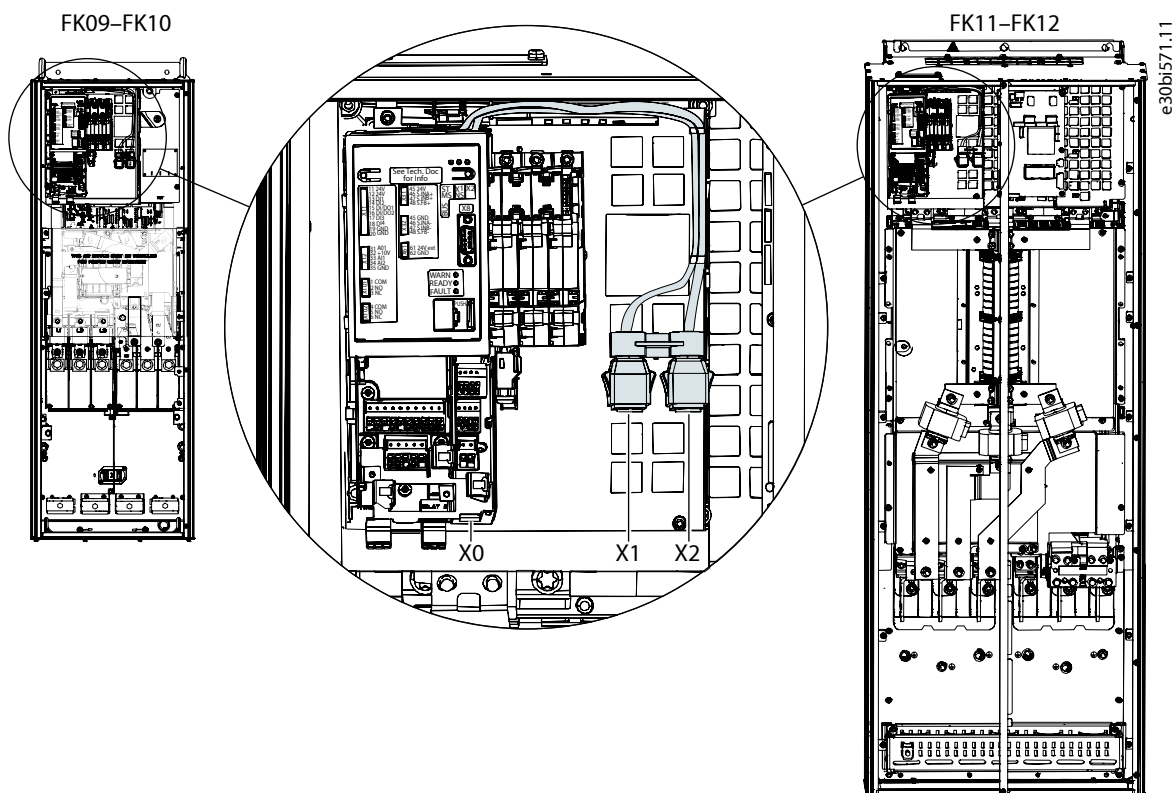

Figure 7: Communication Port X0, X1, and X2 Locations in FB09–FB12/FK09–FK12 Frames

3.3 Installation in System Modules

3.3.1 Communication Interface X1/X2 in System Modules

For systems that use system modules, the communication interface ports are located at the bottom facing side of the modular control unit as shown in [Figure 8](#).

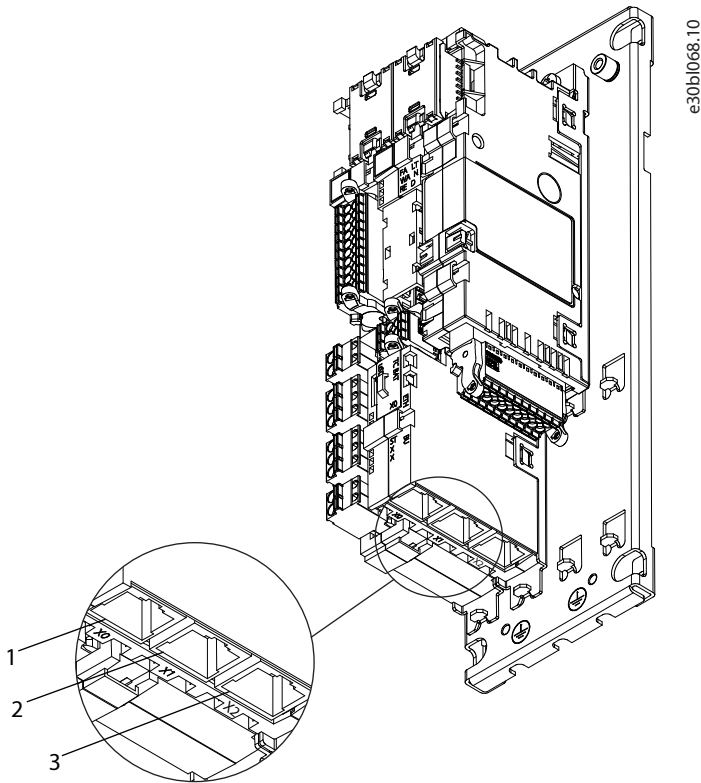

Figure 8: Communication Port X0, X1, and X2 Locations in the Modular Control Unit

1	Ethernet port (X0)	2	Ethernet port (X1)
3	Ethernet port (X2)		

3.4 EMC-compliant Installation

3.4.1 Overview

To obtain an EMC-compliant installation, follow the instructions provided in the product-specific design guide and the installation guide included in the shipment.

3.4.2 Grounding

- Ensure that all stations connected to the fieldbus network are connected to the same ground potential. When distances between the stations in a fieldbus network are long, connect the individual station to the same ground potential. Install equalizing cables between the system components.
- Establish a grounding connection with low HF impedance, for example, by mounting the unit on a conductive backplate.
- Keep the ground wire connections as short as possible.

3.4.3 Cable Routing

For more information on cabling, refer to the product-specific design guide and installation guide included in the shipment.

NOTICE

EMC INTERFERENCE

Failure to isolate fieldbus communication, motor, and brake resistor cables can result in unintended behavior or reduced performance.

- Use shielded cables for motor and control wiring, and separate cables for fieldbus communication, motor wiring, and brake resistor.
- A minimum of 200 mm (7.9 in) clearance between power, motor, and control cables is required. For power sizes above 315 kW (450 hp), increase the minimum distance to 500 mm (20 in).

NOTICE

CABLE ROUTING

- When the fieldbus cable intersects with a motor cable or a brake resistor cable, ensure that the cables intersect at an angle of 90°.

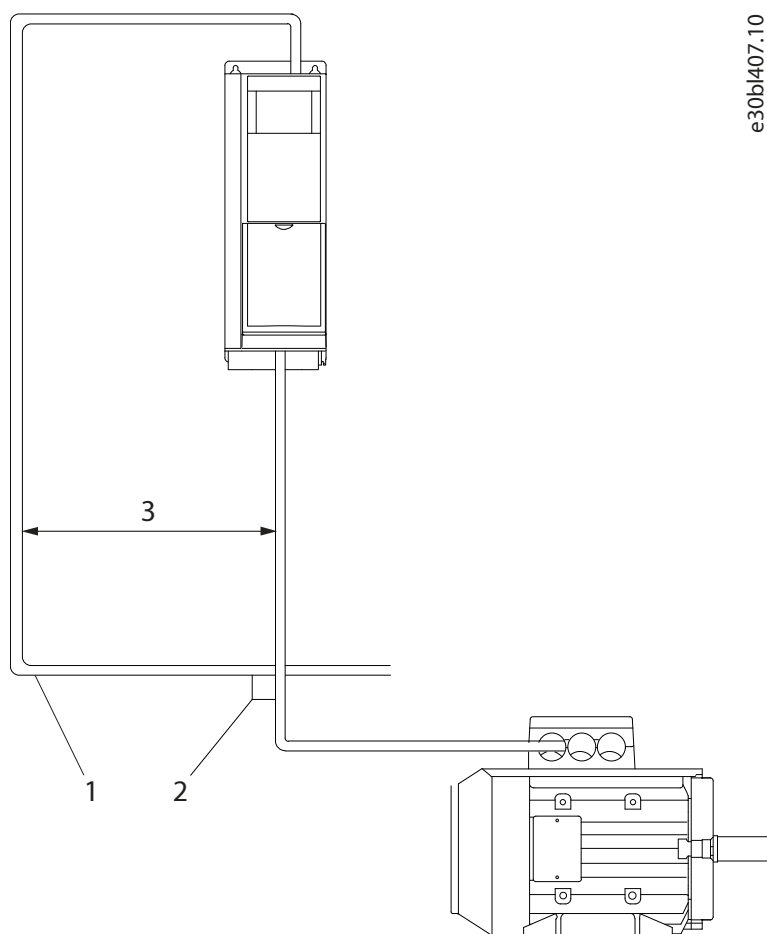

Figure 9: Cable Routing

1	Fieldbus cable	2	90° intersection
3	≥200 mm (7.9 in) (≥ 500 mm (20 in) for power sizes >315 kW (450 hp))		

4 Configuration

4.1 Selecting the Fieldbus Profile

For more information about the available profiles for the application in use, see [Communication Profiles and Objects](#).

1. Navigate to **Parameters > Control Places > Fieldbus Control > Fieldbus Profile**.
2. Select the fieldbus profile.

The selection affects the interpretation of the control word and status word. Selecting a profile may also automatically set specific values for certain parameters or affect control schemes. For details, refer to the application guide.

4.2 Configuring the Ethernet Interface

The X1 and X2 interfaces are internally connected with an Ethernet switch and share the same physical MAC layer, and the same IP settings apply to both interfaces. IPv4 settings are configured in MyDrive® Insight or in the control panel.

1. Configure IPv4 settings.
 - In MyDrive® Insight, go to **Setup and Service > Interface configuration > Interface X1/X2 > IPv4 settings**.
 - In the control panel, navigate to parameter group **Communication Interfaces**.

IMPORTANT: To ensure that outgoing IP packets are routed correctly, configure the IP addresses of the X1/X2 interfaces to a different subnet than the IP address of the X0 interface.

Table 16: IPv4 Settings

Function	Value	Description
Interface X1/X2 MAC address	00:1B:08: xx:xx:xx	The MAC address of interface X1/X2. The value is read-only.
IPv4 addressing method	Disable	Only link-local IP address in the 169.254.xxx.xxx range is active.
	Static IP	A static IP address is entered manually.
	Automatic	IP address is assigned via a DHCP or BOOTP server.
Requested IPv4 address	xxx.xxx.xxx.xxx	If Automatic is selected as the IPv4 addressing method and no DHCP/BOOTP server is present, the X1/X2 interface automatically configures an IP address and subnet mask in the 169.254.xxx.xxx range.
Requested IPv4 subnet mask	xxx.xxx.xxx.xxx	The requested IPv4 subnet mask for the interface.
Requested IPv4 gateway address	xxx.xxx.xxx.xxx	Requested IPv4 gateway address for the interface.
Enable ACD	Enable	Request to enable or disable Address Conflict Detection for the interface. The change does not take effect before a power cycle is performed. If no conflicts are detected, ACD activity shows 0. If an address conflict occurs, the ACD activity shows 1, and the IPv4 interface reverts to an automatically assigned IP address in the 169.254.xxx.xxx range.
	Disable (default)	
DNS server 1, 2	xxx.xxx.xxx.xxx	The user-requested Domain Name Server 1 for the interface (for manual IP addressing mode only).

Table 17: Ethernet Port Configuration (X1/X2)

Parameter name	Parameter number	Selections	Description
<i>Link Configuration X1</i>	7048	<ul style="list-style-type: none"> • Auto negotiation • 10 Mbps full duplex • 10 Mbps half duplex • 100 Mbps full duplex • 100 Mbps half duplex 	Configures the Ethernet link parameter
<i>Link Configuration X2</i>	7049		

4.3 Configuring Fieldbus Protection Settings for the Industry Application

1. Navigate to **Connectivity > Protocols > General Settings**.
2. Configure fieldbus protection settings.

Table 18: Fieldbus Protection Setting Parameters for the Industry Application

Parameter	Parameter number	Value	Description
<i>Fieldbus Fault Response</i>	1303	<ul style="list-style-type: none"> • Info (default) • Warning • Fault, ramp to coast • Fault See Table 19 for descriptions of the events.	Select the behavior when a fieldbus fault, for example loss of I/O connection occurs.
<i>No Fieldbus Connection Response</i>	1327	<ul style="list-style-type: none"> • Info (default) • Warning • Fault, ramp to coast • Fault See Table 19 for descriptions of the events.	Select the response in case there is no fieldbus connection.
<i>Process Data Timeout Time</i>	1340	0.05–18000 s (Default value: 1.00 s)	Set the timeout time. If process data is not received within the time set, a process data timeout is triggered.

Table 18: Fieldbus Protection Setting Parameters for the Industry Application - (continued)

Parameter	Parameter number	Value	Description
Process Data Timeout Response	1341	<ul style="list-style-type: none"> • Info (default) • Warning • Warning - Change Control Place • Warning - Change Control Place - Persistent • Fault, Ramp to Coast • Fault, coast See Table 19 for descriptions of the events.	Select the response to a process data timeout.
Process Data Timeout Control Place	112	<ul style="list-style-type: none"> • Local control • Fieldbus control • I/O control • Advanced control 	Select the alternative control place to be used in case of fieldbus timeout. This is only valid if there is a timeout warning or info.

Table 19: Event Descriptions for the Industry Application

Value	Description
Info	The event is logged in the event log.
Warning	The drive issues a warning. The motor can still be controlled, but with limited performance.
Warning - Change Control Place	The drive issues a warning, and the control place changes to the selected alternative while the timeout warning is active. The control place changes back to the original one when the fieldbus process data returns.
Warning - Change Control Place - Persistent	The drive issues a warning, and the control place changes to the selected alternative while the timeout warning is active. The control place requires a reset command to change back to the original one after the fieldbus process data returns.
Fault, ramp to coast	The drive issues a fault, ramps down, and coasts. Motor control is no longer possible.
Fault	The drive issues a fault and coasts the motor. Motor control is no longer possible.

4.4 Configuring Fieldbus Protection Settings for the Motion Application

1. Navigate to **Connectivity > Protocols > General Settings**.
2. Configure fieldbus protection settings.

Table 20: Fieldbus Protection Setting Parameters for the Motion Application

Parameter	Parameter number	Value	Description
Fieldbus Fault Response	1303	<ul style="list-style-type: none"> • Info (default) • Warning • Fault, ramp to coast • Fault See Table 19 for descriptions of the events.	Select the behavior when a fieldbus fault, for example loss of I/O connection occurs.
No Fieldbus Connection Response	1327	<ul style="list-style-type: none"> • Info (default) • Warning • Fault, ramp to coast • Fault See Table 19 for descriptions of the events.	Select the response in case there is no fieldbus connection.
Process Data Timeout Time	1340	0.05–18000 s (Default value: 1.00 s)	Set the timeout time. If process data is not received within the time set, a process data timeout is triggered.
Process Data Timeout Response	1341	<ul style="list-style-type: none"> • Info (default) • Warning • Warning - Change Control Place • Warning - Change Control Place - Persistent • Fault, Ramp to Coast • Fault, coast See Table 19 for descriptions of the events.	Select the response to a process data timeout.
Process Data Timeout Control Place	112	<ul style="list-style-type: none"> • Local control • Fieldbus control • I/O control • Advanced control 	Select the alternative control place to be used in case of fieldbus timeout. This is only valid if there is a timeout warning or info.

Table 21: Event Descriptions for the Motion Application

Value	Description
Info	The event is logged in the event log.
Warning	The drive issues a warning. The motor can still be controlled, but with limited performance.
Warning - Change Control Place	The drive issues a warning, and the control place changes to the selected alternative while the timeout warning is active. The control place changes back to the original one when the fieldbus process data returns.
Warning - Change Control Place - Persistent	The drive issues a warning, and the control place changes to the selected alternative while the timeout warning is active. The control place requires a reset command to change back to the original one after the fieldbus process data returns.

Table 21: Event Descriptions for the Motion Application - (continued)

Value	Description
Fault, ramp to coast	The drive issues a fault, ramps down, and coasts. Motor control is no longer possible.
Fault	The drive issues a fault and coasts the motor. Motor control is no longer possible.

4.5 Configuring Fieldbus Protection Settings for the Active Front End Application

When using the iC7 series Active Front End application, the fieldbus profile is selected automatically.

1. Navigate to parameter group **Parameters > Protections and Responses > Fieldbus Protections**.
2. Configure fieldbus protection settings.

Table 22: Fieldbus Protection Setting Parameters for the Active Front End Application

Parameter	Parameter number	Value	Description
Fieldbus Fault Response	1304	<ul style="list-style-type: none"> • No response • Info • Warning • Fault (default) • Fault, open MCB See Table 23 for descriptions of the events.	Select the behavior when a fieldbus fault, for example, loss of I/O connection occurs.
No Fieldbus Connection Response	1305	<ul style="list-style-type: none"> • No response (default) • Info • Warning • Fault • Fault, open MCB See Table 23 for descriptions of the events.	Select the response if there is no fieldbus connection.
Process Data Timeout Response	1306	<ul style="list-style-type: none"> • No response • Info (default) • Warning • Fault • Fault, open MCB See Table 23 for descriptions of the events.	Select the response to a process data timeout.
Process Data Timeout Delay	1340	0.05–18000 s (Default value: 1.00 s)	Set a delay for the triggering of the Process Data Timeout event. If process data has not been updated within this delay time the event is triggered.

Table 22: Fieldbus Protection Setting Parameters for the Active Front End Application - (continued)

Parameter	Parameter number	Value	Description
Fieldbus Watchdog Response	5244	<ul style="list-style-type: none"> No response Info Warning (default) Fault Fault, open MCB See Table 23 for descriptions of the events.	Select the converter response for the fieldbus watchdog event.
Fieldbus Watchdog Delay	5245	0.0–3000.0 s (Default value: 5.00 s)	Set a delay for activating the fieldbus watchdog event.
Fieldbus Watchdog Start Delay	5246	0.0–3000.0 s (Default value: 30.00 s)	Set a startup delay time for activating the fieldbus watchdog event. The counter starts when the converter wakes up.

Table 23: Event Descriptions

Value	Description
No response	–
Info	The event is logged in the event log.
Warning	The drive or power converter issues a warning.
Fault	The drive or power converter issues a fault and stops modulation.
Fault, open MCB	The drive or power converter issues a fault, stops modulation, and opens the main circuit breaker.

4.6 Configuring EtherNet/IP Scanner

Danfoss provides an electronic data sheet (EDS), which contains the necessary information for the offline configuration of EtherNet/IP communication.

1. Download the EDS files from www.danfoss.com/en/products/dds/low-voltage-drives/ic7-drives/ic7-automation/#tab-software.

Each iC7 series application requires its own EDS file. Check that the EDS file version is compatible with the firmware version.

2. To configure a drive with EtherNet/IP for operation with a PLC system, install the EDS file.

4.7 Configuring Rockwell Scanner

To configure a Rockwell (Allen-Bradley) scanner to operate with an EtherNet/IP device, the EDS file must be installed using the EDS hardware installation tool. For instructions, see the application guide [iC7 Integration into Rockwell Automation Studio 5000](#).

4.8 Configuring EtherNet/IP Connections

1. Configure I/O connection settings.

For details about the I/O connection settings between the drive and Rockwell Scanner, see the application guide [iC7 Integration into Rockwell Automation Studio 5000](#).

2. Configure Class-1 connection settings.

The class-1 connection is a cyclic I/O connection using TCP transport. The EtherNet/IP interface supports 1 Class-1 connection, but several listen-only connections can be established if multicast is selected as the transport type. The connection is established with a forward open command. See [Table 24](#) for more information.

I/O assembly instances are defined process control objects with defined content comprising control and status information.

Table 24: Assembly Instance Options

Instance	Direction	Size	Data
100	Originator → Target	4 bytes	<ul style="list-style-type: none"> Control word Reference
110 ⁽¹⁾	Originator → Target	6 bytes	<ul style="list-style-type: none"> Control word DC link reference %
130	Originator → Target	80 bytes	Freely selectable
150	Target → Originator	4 bytes	<ul style="list-style-type: none"> Status word Main actual value
160 ⁽¹⁾	Target → Originator	6 bytes	<ul style="list-style-type: none"> Status word DC link actual value %
180	Target → Originator	80 bytes	Freely selectable

1) Available only in the Active Front End application.

Table 25: Supported Connections

Connection point	Type	Description
EO 100/150	Exclusive Owner	The device is controlled by 1 scanner in this assembly.
EO 110/160 ⁽¹⁾		
EO 130/180		
IO 100	Input Only	The scanner receives input data from the device. The data is not sent to the device.
IO 130		
LO 150	Listen Only	A Listen Only connection can be attached to an existing Exclusive Owner or Input Only connection.
LO 180		

1) Available only in the Active Front End application.

Table 26: Supported Transport Types

Direction	Transport type
Originator → Target	Point-to-point
Target → Originator	<ul style="list-style-type: none"> Point-to-point Multicast
Trigger	Cyclic
Packet rate	1 ms minimum supported

3. Configure Class-3 connection settings.

Class-3 Connection is a cyclic connection using UDP transport. The EtherNet/IP interface supports a maximum of 6 Class-3 connections. This type of connection is used for explicit messaging. The connection is established with a forward open-command.

Table 27: Class-3 Connection Parameters

Connection name	Message parameters
Given name for the connection	Service code
	Class
	Instance
	Attribute
	Member
	Request data

4. Configure UCMM settings.

The Unconnected Messages, UCMM is an acyclic connection using TCP transport. This connection is used for explicit messaging. The connection is established on-the-fly and does not require a forward open-command.

Table 28: UCMM Connection Parameters

Connection name	Message parameters
Unconnected messages, UCMM	Service code
	Class
	Instance
	Attribute
	Member
	Request data

For information on accessing CIP objects explicitly, see [6.1.1 Overview](#).

4.9 Reference Handling

4.9.1 Industry and Motion Applications

The speed reference is scaled as a normalized relative value in percent (N2). The value is transmitted in hexadecimal:

- 0% = 0 hex
- 100% = 4000 hex
- -100% = C000 hex

Table 29: Reference Handling Parameters

Parameter	Parameter number	Unit	Range
Nominal Speed	402	[RPM]	0–100000
Positive Speed Limit	1729	[RPM]	0–35400
Negative Speed Limit	1728	[RPM]	-35400–0

For some applications, reversing is not wanted.

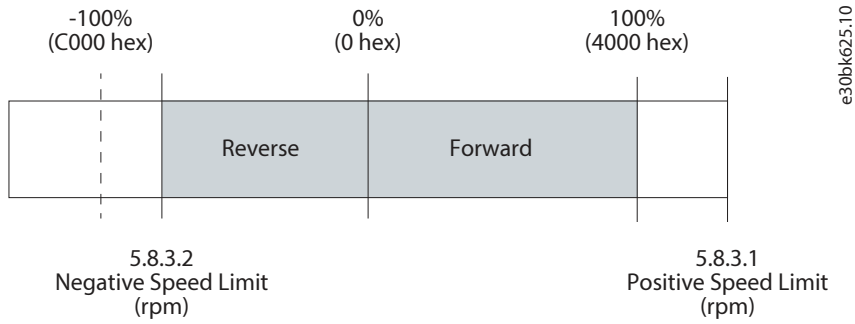

Figure 10: Example of Fieldbus Speed Reference in iC7-Automation

4.9.2 Active Front End Application

For the Active Front End application, the Main Reference [REF] and Main Actual Value [MAV] are tied to the DC-link voltage of the converter. Both of these signals are interfaced as 32-bit floating-point values. They are expressed in % of the **Grid Nominal Voltage** parameter (parameter number **6537**).

5 Troubleshooting

5.1 Configuring Port Mirroring Settings

Enable or disable the port mirroring function for network troubleshooting with a network analyzer tool.

1. In MyDrive® Insight, go to **Setup and Service > Interface Configuration > Port Mirroring Settings**.

Table 30: Port Mirroring Settings

Function	Selections	Description
Source port	<ul style="list-style-type: none"> • X1 • X2 	Frames are mirrored from this port.
Destination port	<ul style="list-style-type: none"> • X1 • X2 	Frames are mirrored to this port.
Block RX from destination port	Enable/Disable	Device does not receive any frames from Destination Port when enabled.
Enable port mirroring	Enable/Disable	Enables the Port Mirroring feature.

5.2 Identifying a Unit

The winking function makes the fieldbus indicator LEDs ST, X1, and X2 flash yellow to make it easy to identify a unit. The function is enabled in MyDrive® Insight.

1. In MyDrive® Insight, click the device name in live mode.
2. Select *Device Status*.
3. To activate or deactivate the feature, click the toggle switch.

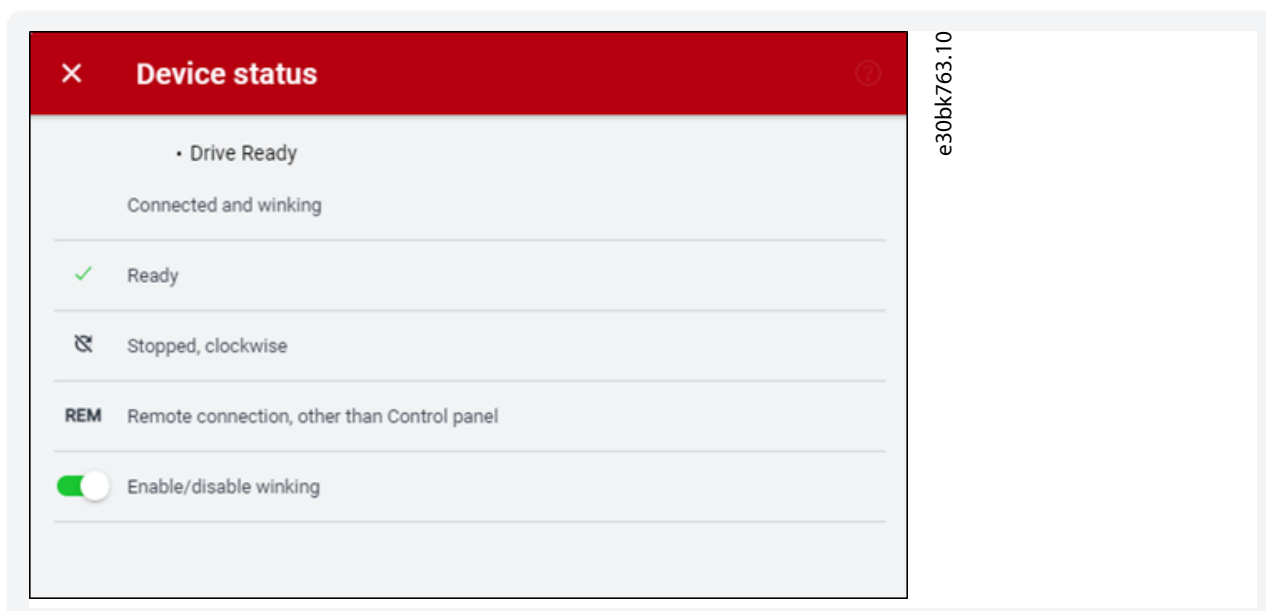

See [5.3 Fieldbus Indicator LEDs](#) for more information on interpreting the LED signals and where the LEDs are located.

5.3 Fieldbus Indicator LEDs

The fieldbus indicator LEDs are in the top right corner of the control panel and the bottom part of the front-facing side of the modular control unit.

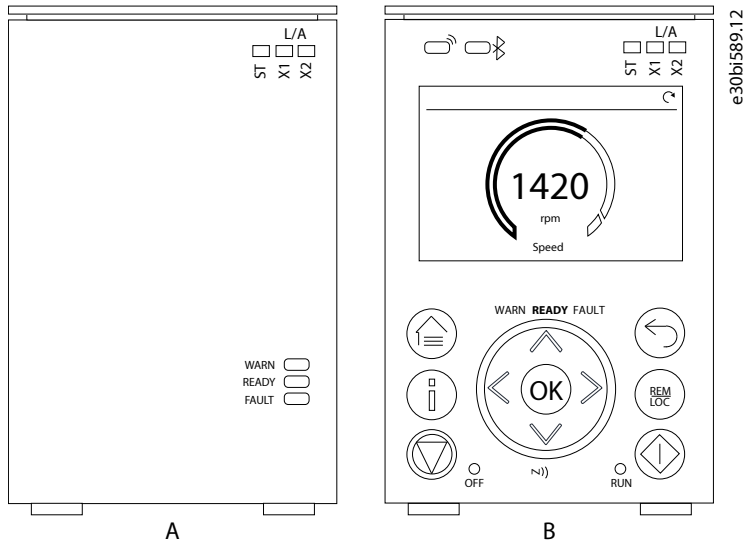

Figure 11: Fieldbus Indicator LEDs on Control Panel

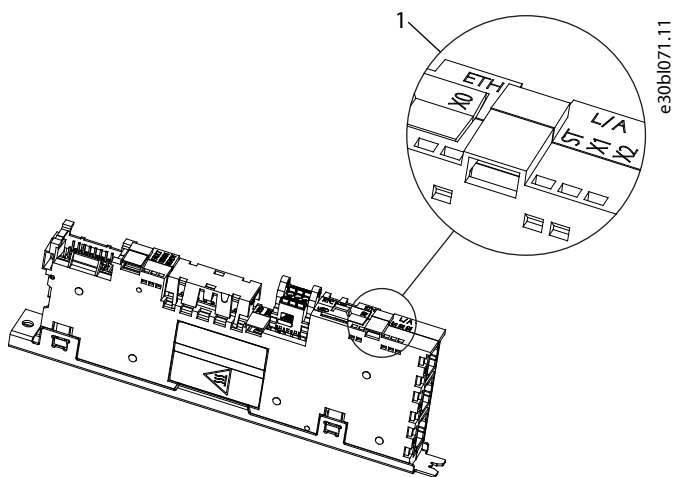

Figure 12: Fieldbus Indicator LEDs on Modular Control Board

1 Fieldbus indicator LEDs (ST, X1, and X2)

- The LED labeled ST shows the module status.
- The LED labeled X1 shows the network status on Ethernet port X1.
- The LED labeled X2 shows the network status on Ethernet port X2.

Table 31: Fieldbus Indicator LED Functions

LED label	Status	LED pattern	Description
ST	Standby	Flashing green	Device needs commissioning.
	Operational	Solid green	Device is operational.
	Recoverable fault	Flashing red	Device has detected a recoverable fault (MAR).
	Unrecoverable fault	Solid red	Device has detected an unrecoverable fault (MAU).
	Flash LED	Flashing red/green	Flash LED service
X1/X2	No link/no IP	LED off	Unknown status
	No connections	Flashing green	No established EtherNet/IP connections
	Connected	Solid green	EtherNet/IP connection
	Connection timeout	Flashing red	One or more EtherNet/IP connection timeouts.
	Duplicate IP	Solid red	IP address assigned to the device is already in use.
	Flash LED	Flashing red/green	Flash LED service

6 EtherNet/IP Features

6.1 Supported CIP Objects

6.1.1 Overview

As in all implementations of CIP, EtherNet/IP shares the common object model. Objects are a common method to describe the specific application implemented in a device.

Data is structured in classes, instances, and attributes:

- A class is a group of objects with the same structure. These groups of objects within a class are called instances.
- Every instance provides the same data elements called attributes.
- Each class provides services to access data or to change the state of an object.

6.1.2 Class ID 0x01 Identity Object

Table 32: Instance Attributes for Class ID 0x01 Identity Object

Attribute	Access	Name	Data type	Description
1	Get	Vendor ID	UINT (97)	Danfoss Drives
2	Get	Device type	UINT (2)	Variable frequency drive
3	Get	Product code	UINT	CIP product code
4	Get	Revision	STRUCT	CIP revision
5	Get	Status	WORD	EtherNet/IP status word
6	Get	Serial number	UDINT	Serial number
7	Get	Product name	STRING	Name of iC7 application
8	Get	State	UINT	0 = N/A 1 = Device self-testing 2 = Standby 3 = Operational 4 = Major recoverable fault 5 = Major unrecoverable fault 6–254 = Reserved 255 = Default for <i>get_attribute_all</i>

6.1.3 Supported Services in Class ID 0x01

Table 33: Supported Services in Class ID 0x01

Service	Value
Reset Service Parameter	0 = Emulated Power Cycle 1 = Factory Reset
Flash LED Service Parameter	Duration in seconds. Flashing red/green/off

6.1.4 Class ID 0x04 Assembly Objects

Table 34: Instance Attributes for Class ID 0x04 Assembly Objects

Instance	Access	Name	Size	Description
100	Set	[CTW], [REF]	4 bytes	Consuming assembly 100
130	Set	[STW], [MAV]	80 bytes	Consuming assembly 130
150	Get	Free configurable	4 bytes	Producing assembly 150
180	Get	Free configurable	80 bytes	Producing assembly 180
768	Set	Configuration	4 bytes	Configuration assembly 768 (for instance 100, 150)
769	Set	Configuration	80 bytes	Configuration assembly 769 (for instance 130, 180)

6.1.5 Class ID 0x06 Connection Manager

Table 35: Instance Attributes for Class ID 0x06 Connection Manager

Attribute	Access	Name	Data type	Description
1	Get	Open requests	UINT	Number of forward open requests received.
2	Get	Open format rejects	UINT	Number of forward open requests rejected due to bad format.
3	Get	Open resource rejects	UINT	Number of forward open requests rejected due to lack of resources.
4	Get	Open other rejects	UINT	Number of forward open requests rejected due to other reasons.
5	Get	Close requests	UINT	Number of forward close requests received.
6	Get	Close format requests	UINT	Number of forward close requests rejected due to bad format.
7	Get	Close other requests	UINT	Number of forward close requests rejected due to other reasons.
8	Get	Connection timeouts	UINT	Number of connection timeouts.

6.1.6 Class ID 0x47 DLR (Device Level Ring)

Table 36: Instance Attributes for Class ID 0x47 DLR (Device Level Ring)

Attribute	Access	Name	Data type	Description
1	Get	Network topology	USINT	Current network topology mode: 0 = Linear 1 = Ring
2	Get	Network status	USINT	Status of network: 0 = Normal 1 = Ring fault 2 = Unexpected loop detected 3 = Partial network fault 4 = Rapid fault/restore cycle
10	Get	Active supervisor address	Struct of:	–
		Supervisor IP address	UDINT	A Value of 0 indicates that no IP Address has been configured for the device.
		Supervisor MAC address	Array of 6 USINTs	Ethernet MAC address
12	Get	Capability flags	DWORD	DLR capabilities of the device. iC7series drives are beacon-based nodes.

6.1.7 Class ID 0x48 Quality of Service Object

Table 37: Instance Attributes for Class ID 0x48 Quality of Service Object

Attribute	Access	Name	Data type	Description
1	Get/Set	802.1Q tag enable	USINT	Enables or disables sending 802.1Q frames on CIP and IEEE 1588 messages. A value of 0 indicates tagged frames disabled. A value of 1 indicates tagged frames enabled.
4	Get/Set	DCSP urgent	USINT	DSCP value for CIP transport class 0/1 urgent priority messages.
5	Get/Set	DCSP scheduled	USINT	DSCP value for CIP transport class 0/1 scheduled priority messages.
6	Get/Set	DCSP high	USINT	DSCP value for CIP transport class 0/1 high priority messages.
7	Get/Set	DCSP low	USINT	DSCP value for CIP transport class 0/1 low-priority messages.
8	Get/Set	DCSP explicit	USINT	DSCP value for CIP explicit messages (transport class 2/3 and UCMM) and all other EtherNet/IP encapsulation messages.

6.1.8 Class ID 0xF5 TCP/IP Interface Object

Table 38: Instance Attributes for Class ID 0xF5 TCP/IP Interface Object

Attribute	Access	Name	Data type	Description
1	Get	Status	DWORD	Interface status
2	Get	Config. capability	DWORD	Interface capability flags
3	Get/Set	Config control	DWORD	Interface control flags
4	Get	Physical link object	Struct of:	–
		Path size	UINT	Size of path
		Path	Padded EPATH	Logical segments identifying the physical link object.
5	Get/Set	Interface config:	Struct of:	TCP/IP network interface configuration
		IP address	UDINT	The device IP address
		Network mask	UDINT	The device network mask
		Gateway address	UDINT	Default gateway address
		Name server	UDINT	Primary name server
		Name server 2	UDINT	Secondary name server
		Domain name	STRING	Default domain name
6	Get/Set	Host name	STRING	Host name
8	Get/Set	TTL value	USINT	Time-to-Live value for IP multicast packets. The default value is 1.
9	Get/Set	Multicast config	Struct of:	–
		Num Mcast	UINT	Number of IP multicast addresses to allocate for EtherNet/IP.
		Multicast start address	UDINT	Starting multicast address from which to begin allocation, A block of Num Mcast addresses is allocated starting with this address.
10	Get/Set	Select ACD	BOOL	Enable ACD: 0 = Disabled (default) 1 = Enabled
11	Get	Last conflict detected	Struct of:	–
		ACD activity	USINT	State of ACD activity when the last conflict was detected.
		Remote MAC	Array of 6 USINT	MAC address of a remote node from the ARP PDU in which a conflict was detected.
		ArpPdu	Array of 28 USINT	Copy of the raw ARP PDU in which a conflict was detected.
13	Get/Set	Encap. inactivity timeout		Number of seconds of inactivity before the TCP connection is closed.

6.1.9 Class ID 0xF6 Link Object

3 instances of the link object are implemented:

- Instance 1 relates to the internal interface of the option after the built-in switch.
- Instance 2 relates to Ethernet port X1.
- Instance 3 relates to Ethernet port X2.

Table 39: Instance Attributes for Class ID 0xF6 Link Object

Attribute	Access	Name	Data type	Description
1	Get	Interface speed	UDINT	Interface speed in Mbps
2	Get	Interface flags	DWORD	Interface status flags
3	Get	Physical address	ARRAY of 6 USINTs	MAC layer address
4	Get	Interface counters	Struct of:	–
		In octets	UDINT	Octets received on the interface.
		In Ucast packets	UDINT	Unicast packets received on the interface.
		In NUcast packets	UDINT	Non-unicast packets received on the interface.
		In discards	UDINT	Inbound packets are received on the interface but discarded.
		In errors	UDINT	Inbound packets that contain errors (does not include In Discards).
		In unknown protos	UDINT	Inbound packets with unknown protocol.
		Out octets	UDINT	Octets sent on the interface.
		Out Ucast packets	UDINT	Unicast packets sent on the interface.
		Out NUcast packets	UDINT	Non-unicast packets sent on the interface.
		Out discards	UDINT	Outbound packets discarded.
Out errors	UDINT	Outbound packets that contain errors.		

Table 39: Instance Attributes for Class ID 0xF6 Link Object - (continued)

Attribute	Access	Name	Data type	Description
5	Get	Media counters	Struct of:	–
		Alignment errors	UDINT	Frames received that are not an integral number of octets in length.
		FCS errors	UDINT	Frames received that do not pass the FCS check.
		Single collisions	UDINT	Successfully transmitted frames which experienced exactly 1 collision.
		Multiple collisions	UDINT	Successfully transmitted frames which experienced more than 1 collision.
		SQE test errors	UDINT	Number of times an SQE test error message is generated.
		Deferred transmissions	UDINT	Frames for which the 1st transmission attempt is delayed because the medium is busy.
		Late collisions	UDINT	Number of times a collision is detected later than 512 bit times into the transmission of a packet.
		Excessive collisions	UDINT	Frames for which transmission fails due to excessive collisions.
		MAC transmit errors	UDINT	Frames for which transmission fails due to an internal MAC sub layer transmit error.
		Carrier sense errors	UDINT	Times that the carrier sense condition was lost or never asserted when attempting to transmit a frame.
		Frame too long	UDINT	Frames received that exceed the maximum allowed frame size.
MAC receive errors	UDINT	Frames for which reception on an interface fails due to an internal MAC sub layer receive error.		
6	Set	Interface control	Struct of:	–
		Control bits	WORD	Interface control bits
		Forces interface speed	UINT	The speed at which the interface is forced to operate (speed in Mbps).
7	Get	Interface type	SHORT_STRING	Type of interface: 1 = internal 2 = twisted pair
8	Get	Interface state	USINT	Current state of the interface: 0 = Unknown state 1 = Operational 2 = Disabled

Table 39: Instance Attributes for Class ID 0xF6 Link Object - (continued)

Attribute	Access	Name	Data type	Description
9	Get/Set	Admin state		Administrative state: 1 = Enable 2 = Disable
10	Get	Interface label	SHORT_STRING	Human readable identification
11	Get	Interface capabilities	Struct of:	Interface speed and Duplex mode



Danfoss A/S
Ulsnaes 1
DK-6300 Graasten
drives.danfoss.com

Any information, including, but not limited to information on selection of product, its application or use, product design, weight, dimensions, capacity or any other technical data in product manuals, catalog descriptions, advertisements, etc. and whether made available in writing, orally, electronically, online or via download, shall be considered informative, and is only binding if and to the extent, explicit reference is made in a quotation or order confirmation. Danfoss cannot accept any responsibility for possible errors in catalogs, brochures, videos and other material. Danfoss reserves the right to alter its products without notice. This also applies to products ordered but not delivered provided that such alterations can be made without changes to form, fit or function of the product. All trademarks in this material are property of Danfoss A/S or Danfoss group companies. Danfoss and the Danfoss logo are trademarks of Danfoss A/S. All rights reserved.

M00423
AQ456329199699en-010201
Danfoss A/S © 2026.05

