

ENGINEERING
TOMORROW

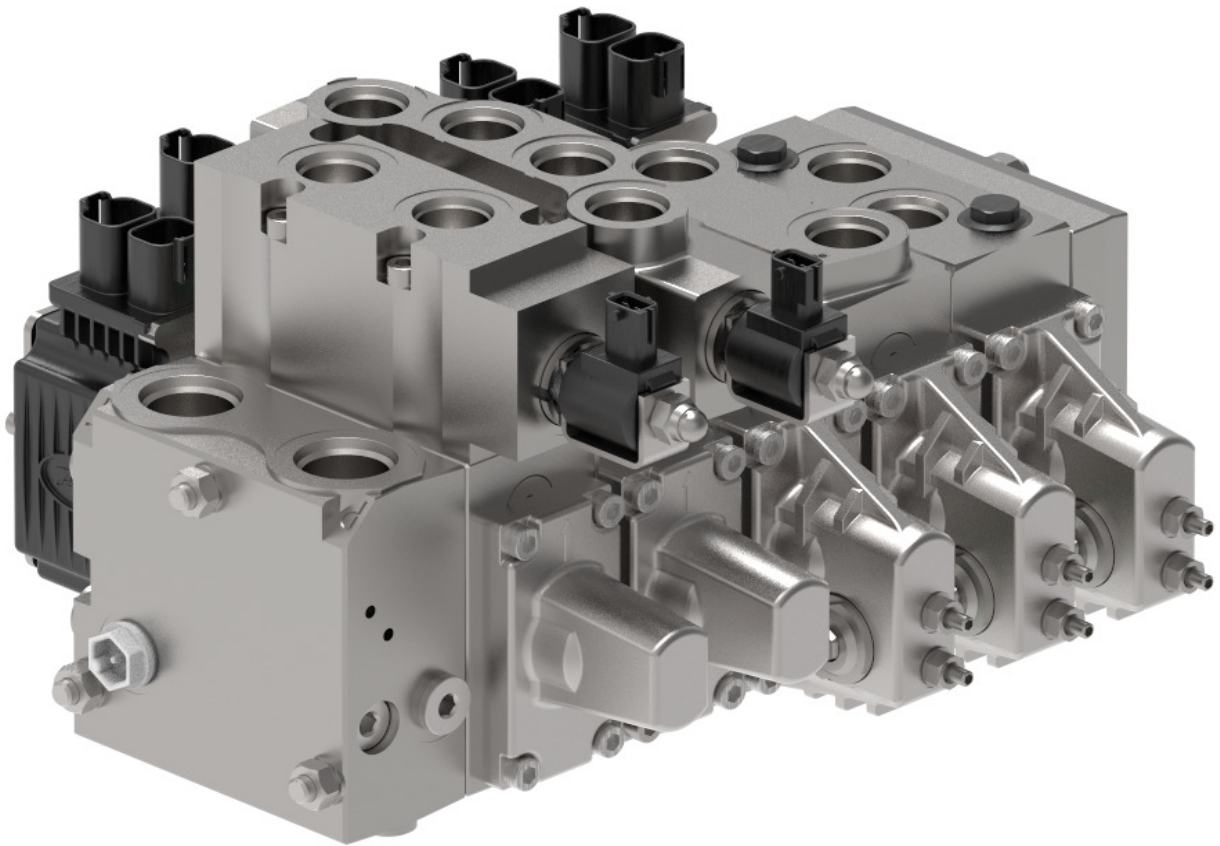

Technical Information

Proportional Valve Group PVG 32 Agriculture



Revision history

Table of revisions

Date	Changed	Rev
Jun 2026	Front page image updated, and minor revisions throughout	0107
Jun 2017	Corrected PVG32 technical parameters table	0106
Feb 2014	Converted to Danfoss layout – DITA CMS	AE
Mar 2012	Layout changes, and change in the table, page 21.	AD
Mar 2010	New back cover	AC

Contents

Literature reference for PVG products

Introduction

Short overview.....	5
Hitch control.....	5
Sectional view.....	6

PVG 32 function

Warning.....	7
--------------	---

Technical data

PVG 32 technical parameters.....	8
----------------------------------	---

PVBZ basic module for EH auxiliary valve functions

PVBD, PVBZ with optional diverter feature

Principle description of PVBD diverter.....	12
---	----

PVG 32 hitch control valves

General introduction.....	13
PVBZ-HS basic module (hitch single-acting).....	13
PVBZ-HD basic module (hitch double-acting).....	14

PVP with integrated HPCO

Modules and code numbers

PVB, inlet basic modules.....	18
PVBZ auxiliary modules.....	19
PVBZ-HS/-HD modules, PVBD diverter, multi-valve (for PVBZ-HD).....	20
PVBS spools.....	21

Activation characteristics

Characteristic of oil flow, spool travel and voltage.....	23
---	----

Pressure drop characteristics

Pressure drop characteristics of float spools.....	24
Single acting spools characteristics for PVBZ-HS	27
Pressure drop characteristic in lower mode position, max. spool travel.....	27
Spools characteristics for PVBZ-HD.....	28

Dimensions and schematics

Drawings for 5-section group.....	30
Drawings for 3-section group.....	32
Drawings for 2-section group.....	34

Literature reference for PVG products

Literature reference

Literature title	Type	Order number
PVG 32 Proportional Valve Group	Technical Information	BC152886483 664
PVG 100 Proportional Valve Group	Technical Information	BC152886483 475
PVG 120 Proportional Valve Group	Technical Information	BC152886483 344
PVG 32 Metric ports	Technical Information	BC152886484 163
PVE Series 7	Technical Information	BC173386484 192
PVE Series 4	Technical Information	BC152886484 010
PVED-CC Electro-hydraulic actuator	Technical Information	520L0665
PVED-CX Electro-hydraulic actuator	Technical Information	BC152886483 682
PVE-CI	Technical Information	BC163786485 206
Basic module for PVBZ	Technical Information	BC152886484 167
PVSK module with integrated diverter valve and P-disconnect function	Technical Information	BC152886484 133
PVPV / PVPM pump side module	Technical Information	BC152886484 316
Combination module PVGI	Technical Information	BC152886483 392
PVSP/M Priority module	Technical Information	BC152886484 066
Hitch Control	System Description	AB152886482 484
	User Manual	11033753
PVBZ	Data Sheet	AI1528864823 57
PVBZ-HS	Data Sheet	AI1528864822 19
PVBZ-HD	Data Sheet	AI1528864821 40
MC024-010 and MC024-012 Controllers	Data Sheet	AI1528864807 85

Introduction

Metric ports

We have developed a range of modules with metric ports. These modules comprise of various inlets, working modules for auxiliary functions, hitch modules, special top mounted modules and endplates. The range of our PVE - Series 7 is used as actuation.

The target application area for this product range is mainly Agriculture – especially complete EH valve solutions for tractors, but also other applications can benefit from the offered features.

Short overview

Besides the inlets suited for fixed as well as for LS-controlled variable piston pumps, you will find a range of valve modules listed. These valves enable you to assemble a valve solution using EH Aux valves and hitch valves for tractors.

The PVE Series 7 generation with either analogue and digital pilot heads offers multiple possibilities of customizing valves for individual needs – ranging from simple analogue versions to fully ISOBUS compliant actuators with numerous variants in between, analogue as well as digital.

PVG 32 parts description

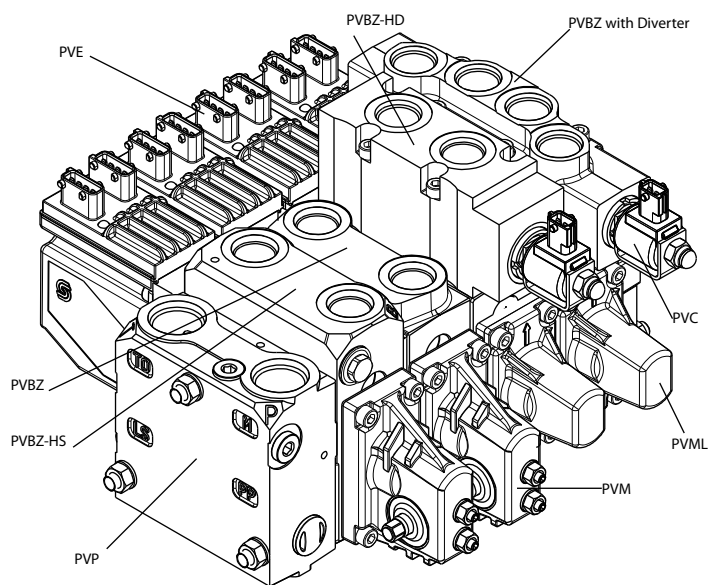

V310070.A

Hitch control

Together with the introduction of this product range, Danfoss has developed a hitch control SW block available in our PLUS+1® GUIDE which on base of a PLUS+1 controller can offer a Hitch control system for tractors.

These components allow for design of hitch systems that incorporate intuitive control as well as a number of innovative new solutions. The components available offer significant advantages in controlling both the single and double acting systems, including easy understanding of both Force and Slip control. In addition to performing state of the art operation of hitch, the software block contains logic that ensures the full potential of the Danfoss hitch valves are exploited.

The technical information references mentioned describes the Danfoss concept behind the operation of a hydraulic hitch system, and the different types of systems and components available from Danfoss.

Introduction

Sectional view

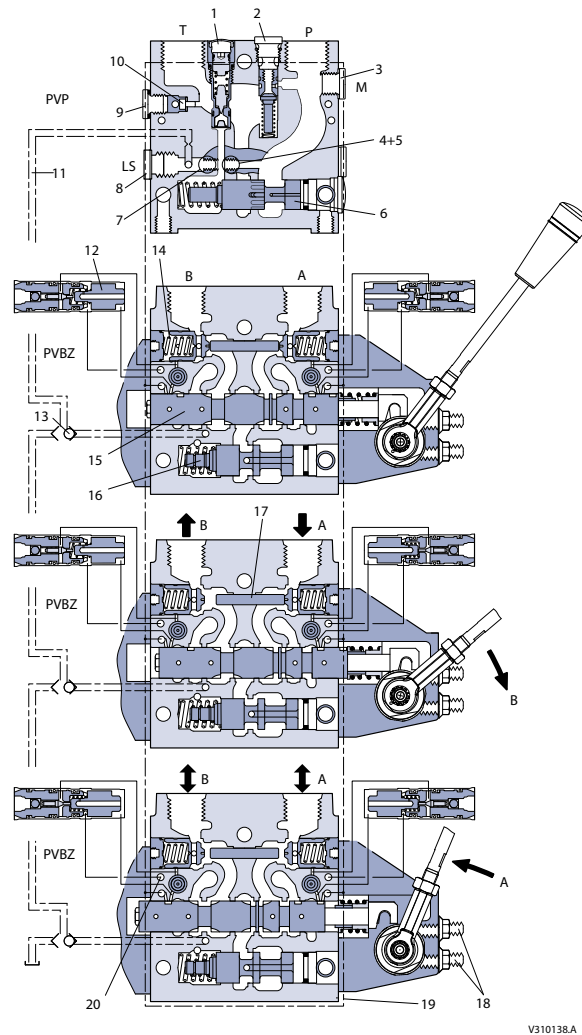

Legend:

- | | |
|--|--|
| 1. Pressure relief valve | 11. LS signal |
| 2. Pressure reduction valve for pilot oil supply | 12. Pilot valve for POC |
| 3. Pressure gauge connection | 13. Shuttle valve |
| 4. Plug, open centre | 14. Pilot operated check valve, POC |
| 5. Orifice, closed centre | 15. Main spool |
| 6. Pressure adjustment spool | 16. Compensator |
| 7. Plug, closed centre | 17. Shuttle pin |
| 8. LS connection | 18. Max. oil adjustment screws for ports A and B |
| 9. T0 connection | 19. Pilot supply for PVE |
| 10. Plug to be removed for internal T0
(157B: 5130, 5131, 5330 and 5331 only) | 20. Separate tank line, (T0) |

PVG 32 function

When main spools (15) are in neutral position, the pilot operated check valves (hereafter PO Check valves) are kept closed by a spring plus the work port load, which is directed to the spring side of the PO Check valves (14) via a small orifice.

If a main spool is actuated to have flow out of the B port, the meter out flow forces the respective PO Check valves valve to open. At the same time, pilot pressure is guided via the main spool to the back side of a small pilot valve (12) on the A port side. This will ensure that the load pressure behind the PO Check valves is released to a separate tank T0 (20) via a seat valve and allow the PO Check valves to open and let return flow pass across the main spool back to tank.

For float function, both PO Check valves are released to tank at the same time as described above.

In some applications with low load pressure, it is necessary to force open the PO Check valves by a pin (17). This pin is actuated by means of pump pressure on the A port side.

PVBZ modules cannot be optionally mounted (PVM on A - Port side only).

The separate tank connection T0 is needed to ensure proper performance of the PO Check valves regardless of the pressure in main tank line T. It is therefore necessary to connect the T0 port in the Inlet VVP direct to the oil reservoir with a separate hose, see dimensional drawing examples.

All the valve modules in this technical information have a T0 gallery.

When using PVP with HPCO function (T port can be pressurised) please make sure to lead return flow from the A and B ports to tank via a separate tank port in the end plate PVST.

Warning

Warning

All makes and all types of directional control valves – inclusive proportional valves – can fail and cause serious damage. It is therefore important to analyse all aspects of the application. Because the proportional valves are used in many different operation conditions and applications, the manufacturer of the application is responsible for making the final selection of the products- and assuring that all performance, safety and warning requirements of the application are met. The process of choosing the control system – and safety level – could e.g. be governed by ISO 13849 (Safety related parts of control system).

Technical data

PVG 32 technical parameters

Max. pressure	Port P continuous		350 bar	[5076 psi]
	Port A/B / without P/O checks		350 bar	[5076 psi]
	Port T, static/dynamic		25 / 40 bar	[362 / 580 psi]
	Port T Hitch Single-Acting Module		25 bar	[362 psi]
Oil flow, rated	Port P		140 l/min	[37.0 US gal/min]
	Port A/B, with press. comp.		100 l/min	[26.4 US gal/min]
Spool travel, standard			± 7 mm	[±0.28 in]
Spool travel, float position spool	Proportional range		± 5.5 mm	[±0.22 in]
	Float position		7.5 mm	[±0.30 in]
Dead band, flow control spool	Standard		± 0.8 mm	[±0.03 in]
Max. internal leakage at 200 bar [2900 psi] and 21 mm²/s [102 SUS]	A/B → T	PVBZ with PO Check valves	1 cm ³ /min	[0.06 in ³ /min]
		PVBZ with PO Check valves and PVL P	6 cm ³ /min	[0.37 in ³ /min]
		PVB with PVL P	25 cm ³ /min	[1.53 in ³ /min]
Oil temperature (inlet temperature)	Recommended		30 → 60°C	[86 → 140°F]
	Min. temperature		-30°C	[-22°F]
	Max. temperature		+90°C	[194°F]
Ambient temperature			-30 → +60°C	[-22 → +140°F]
Oil viscosity	Operating range		12 - 75 mm ² /s	[65 - 347 SUS]
	Min. viscosity		4 mm ² /s	[39 SUS]
	Max. viscosity		460 mm ² /s	[2128 SUS]
Filtration	Max. contamination (ISO 4406)		18/16/13	18/16/13

PVBD, 6/2 diverter valve

Max pressure PVBZ module with mounted diverter PVBD, Port A/B	280 bar [4061 psi]
Oil flow max recommended, rated PVBZ module with mounted diverter PVBD	80 l/min [21.1 US gal/min]

Multi-valve, Single-action / Double-action

Max pressure PVBZ module with mounted multi valve, Port A/B	280 bar [4061 psi]
Oil flow, rated PVBZ module with mounted multi valve, Port A/B	100 l/min [26.4 US gal/min]

PVBZ basic module for EH auxiliary valve functions

The PVBZ valve is a load and pressure compensated valve module with two pilot operated check valves (PO Check valves) in the A- and B-ports. These are limiting the work port leakage to a very low limit, below 1 cm³/min.

PVBZ modules will always have 2 PO Check valves one in each work port.

Besides compensation, the pressure compensator can limit the work port pressure blow up to 4 - 5 bar. The special PVBZ load compensated module was developed for applications that require integrated pilot operated check valves in the work ports that required to limit the port leakage to zero. See [Technical data](#).

The PVBZ basic module can be mixed with basic modules PVB (with additional tank line T0).

Features:

- Integrated pilot operated check valves for limited internal leakage
- Can be mixed with PVB with T0 gallery
- LS a/b shuttle for float spools
- Standard 4/4 float spools
- Integrated thermo relief valve as option (modules with threaded ports only)
- Manifold version for Danfoss designed valves or customer designed quick coupler block
- Compensator with bleed off
- Auxiliary valve on tractors for function control on implements; cylinder positioning and speed control of hydraulic motors.

PVBZ, load and pressure compensated valve module with two PO check valves in A/B-ports

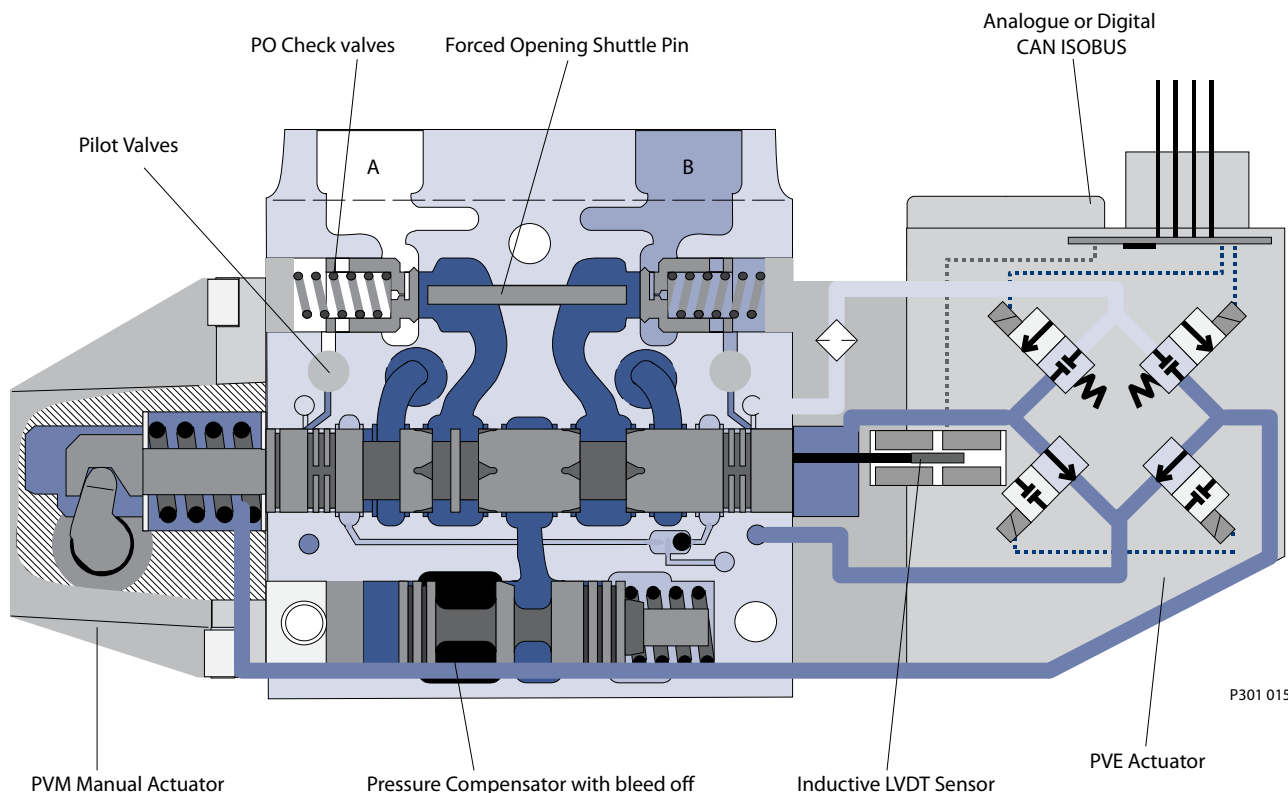

PVBZ parameters

Maximum pressure	Port P continuous	250 bar [3625 psi]
	Port A/B	280 bar [4061 psi]
Oil flow, rated	Port A/B, with press. comp.	100 l/min [26.4 US gal/min]

PVBZ basic module for EH auxiliary valve functions

PVBZ parameters (continued)

Spool travel, standard	Proportional range	± 7 mm [±0.28 in]
Spool travel, float position spool	Proportional range	± 5.5 mm [±0.22 in]
	Float position	7.5 mm [±0.30 in]
Dead band, flow control spool	Standard	± 0.8 mm [±0.03 in]
Max. internal leakage at 150 bar [2175 psi] and 21 mm ² /s [102 SUS]	A/B → T	1 cm ³ /min [0.06 in ³ /min]

PVBD, PVBZ with optional diverter feature

The utilization of a PVBZ module can be further enhanced by adding a diverter valve. Mounted on top of the PVBZ valve slice, a 6/2 PVBD diverter valve can direct valve flow to either of two set of ports (A1/B1 or A2/B2). The PVBD diverter spool (shift spool) is actuated by the PVC solenoid valve by means of pilot pressure.

Features:

- Enlarge the application range (2 functions)
- To be mounted on top of PVBZ modules
- Pilot operated with PVC
- Auxiliary valve on tractors for function control on implements: cylinder positioning when the demand on neutral port leakage is limited.

PVBD, PVBZ with optional diverter feature

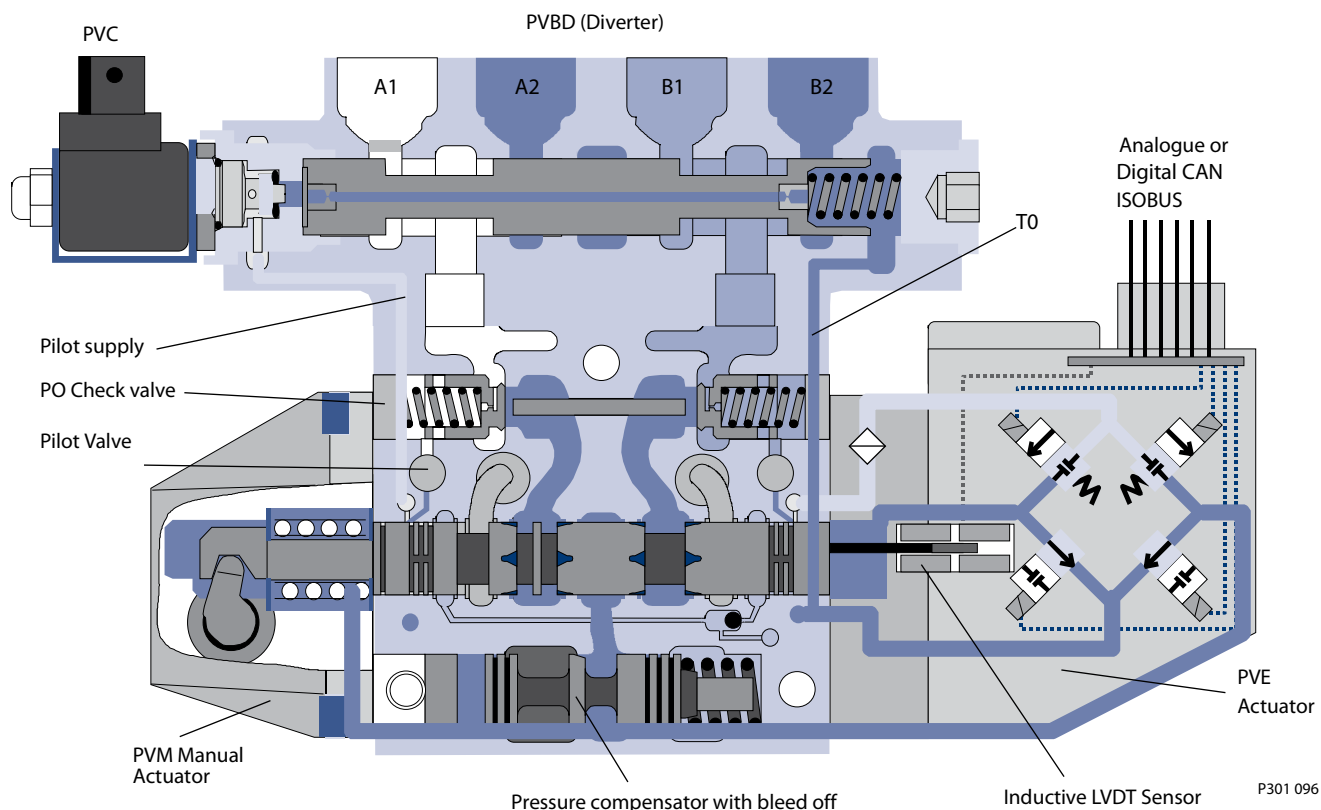

PVBD parameters

Max. pressure, Port A/B		280 bar [4061 psi]
Oil flow rated, max recommended		80 l/min [21.1 US gal/min]
Leakage levels * A1, A2, B1, B2 port		10 ml/min @ 70 bar 30 ml/min @ 210 bar
Pressure drop* A/B to A1/B1 or A2/B2 or vice versa		0.5 bar @ 40 l/min [7.3 psi @ 10.6 US gal/min] 2 bar @ 80 l/min [29 psi @ 21.1 US gal/min]
Pilot oil consumption	PVC off / PVC on	0 / 0.3 l/min
Environmental specifications	Temperature Oil viscosity, etc.	See PVBZ basic module for EH auxiliary valve functions on page 9
PVC solenoid (NC) connector	Zener diode included	AMP JPT 2 Pin
Safety recommendations		Shift of the diverter should only be possible when the main spool is in neutral.

PVBD, PVBZ with optional diverter feature

Principle description of PVBD diverter:

- PVC off: The shift spool is held in position (flow to A1/B1) by the spring in the right hand side (opposite the PVC). The spring chamber is always connected to the T0 gallery in the PVBZ body.
- PVC on: Pilot pressure is led into the chamber next to the PVC. A limited flow is passing through the shift spool and the two orifices and into the spring chamber connected to T0. Pressure-drop across the orifices creates the shift force moving the shift spool towards the spring. As a result, port A2/B2 becomes active.

Leakage (along the spool clearance) from pressurized work ports A1/B1 or A2/B2 will always be drained to T0 either directly in the spring chamber or through the shift spool. This secures safe positioning of the shift spool as leakage never will build up pressure up in the control chambers.

Safety recommendation: Shift of the diverter should only be possible when the main spool is in neutral. This has to be ensured through a proper set-up in the controller/MMI hardware.

PVG 32 hitch control valves

General introduction

Two types of hitch valves are available for hitch or similar applications. The two valve options offered are the PVBZ-HS, single acting and the PVBZ-HD, double acting.

The PVBZ-HS matches the market standard whereby implements are raised hydraulically and lowered only by the pull of gravity. The PVBZ-HD has the unique ability to raise and lower either as single- or double-acting.

The benefits of the PVBZ-HD reflect a departure from old hitch norms - increased comfort when attaching implements due to the same speed up and down and safer detachment of heavy implements from the driver's seat.

The full benefit of the possibilities with the PVBZ-HD is easily obtained by use of the PLUS+1® hitch core application block. The core application block shifts the valve between single- and double-acting hitch according to the most suitable operation.

The operator will not have to select the operation but will notice the benefits during normal operation of the hitch. Work-modes are single-acting as it is standard today, but manual operation up and down are double-acting to increase comfort, functionality and safety.

For further info and more details please see the Danfoss *Hitch control System description*, see [Literature reference](#).

PVBZ-HS basic module (hitch single-acting)

Single acting PVBZ-HS slice for standard hitch application.

It has its own tank port to direct the return flow directly into the tank with a minimum of back pressure. This prevents tank-line pressure influence, especially when lowering the un-loaded (empty) hitch under cold conditions (high oil viscosity).

Similar to the auxiliary slice, the single acting PVBZ-HS slice is a pressure-compensated valve slice with one P/O check valve on B-port only. The same technology as in the PVBZ module is used.

Besides the flow paths, the spool is directing the pilot pressure to the pilot valve for P/O check valve pressure release as well as to the shuttle pin in order to force the P/O popped to open under low load conditions. This ensures a fully open flow path in lower mode.

The B-port is normally equipped with a PVLP shock valve.

PVBZ-HS incorporates a compensator with bleed-off to prevent pressure building up between the pump gallery and the work ports.

A special 3/3 spool with optimized flow characteristics, both in meter-out as well as in meter-in direction, has to be controlled by a high performance actuator.

Features:

- Low leakage work port
- Separated tank port
- Integrated PVLP shock/anti cavitation valves
- Can be mixed with PVB/ PVBZ with T0 gallery
- Compensator with bleed off
- Rear-Hitch on tractors
- Header control on combines and harvesters

PVG 32 hitch control valves

Hitch single-acting valve module

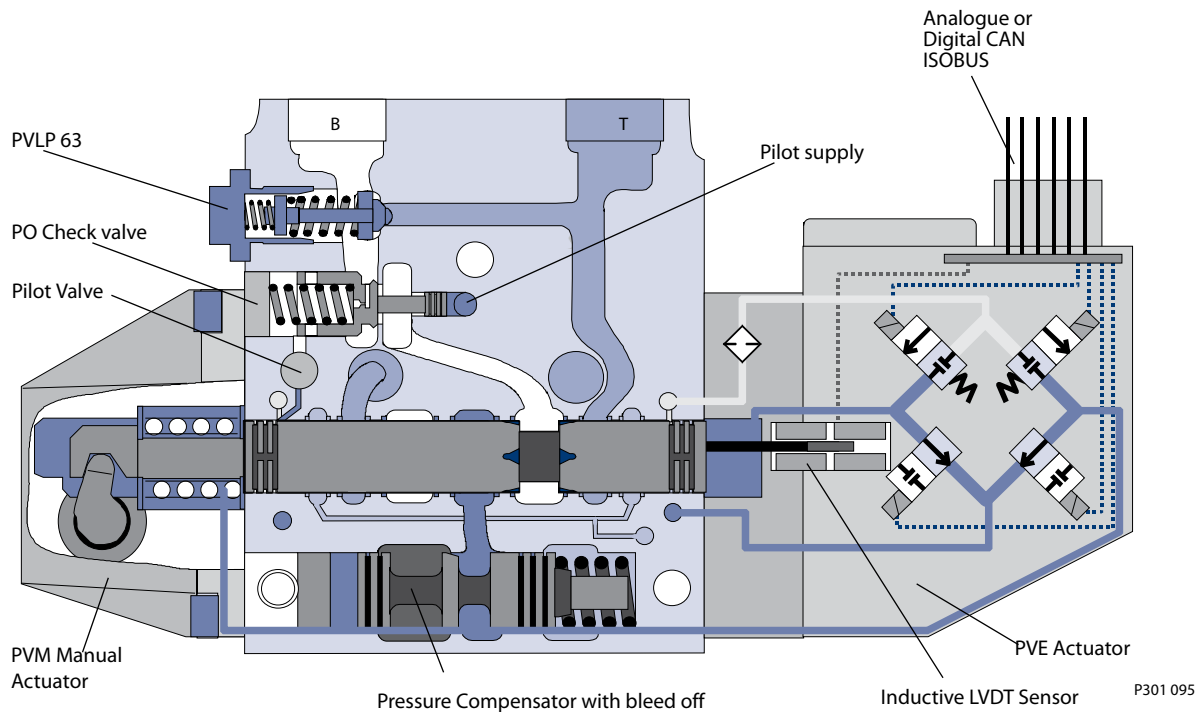

PVBZ-HS parameters

Maximum pressure	Port P continuous	250 bar [3625 psi]
	Port B	280 bar [4061 psi]
	Port T, static/dynamic	25 bar/40 bar [365/580 psi]
Oil flow, rated, Port B, with press. comp.		100 l/min [26.4 US gal/min]
Spool travel, standard		± 7 mm [±0.28 in]
Dead band, flow control spool, standard		± 0.8 mm [±0.03 in]
Max. internal leakage at 150 bar [2175 psi] and 21 mm ² /s [102 SUS]	B → T, with PVLP	6.0 cm ³ /min [0.37 in ³ /min]

Safety recommendations for the OEM and user.

To avoid unintended raise of the empty hitch the tank port on PVBZ-HS always has to be connected direct to tank without any restriction or pressure build up possibilities.

This also ensures lowering in lower mode under cold conditions (high viscosity oil).

In case of manual actuation of the Hitch function (limp home mode) the power supply to the PVE has to be disabled before the PVM (hexagon) can be actuated.

The OEM /end user needs to be aware of the dangerous operation when performing manual raise/lowering of the hitch and be close to the hitch arms.

PVBZ-HD basic module (hitch double-acting)

The double-acting hitch slice consists of the PVBZ valve-section with a flanged-on single/double-acting selector (multi-valve) actuated by a PVC valve.

By energizing or de-energizing the PVC, the multi-valve shifts the slice between single- or double-acting work-modes. This is of great benefit in hitch applications both for rear and front hitches. When the slice is operating as single-acting, the A-port is connected to tank in the PVBZ body.

PVG 32 hitch control valves

The PVBZ base of the PVBZ-HD has similar features as the PVBZ valve-slice. That is PO Check valves for low leakage as well as compensator with bleed-off to eliminate pressure build-up between compensator and work-ports.

The flanged on multi-valve contains the shifting spool to switch port A between T and port A of the PVBZ. It also contains a PVLP shock/suction valve on port B.

The change between single- and double-acting modes is operated independently of valve-flow command.

Features:

- Low leakage work port (B-port)
- Standard 4/4 float spools to be used
- Electrical mode shift into pure 3/3 single acting functionality of double acting cylinder
- Integrated PVLP shock/anti cavitation valves (B-port)
- Single and Double Acting (see Hitch Control System Description for detailed set-up and benefits)
- Compensator with bleed off
- Rear and front hitch linkages on medium and higher performance tractors.
- Header control on combines and harvesters.

Hitch double-acting valve module

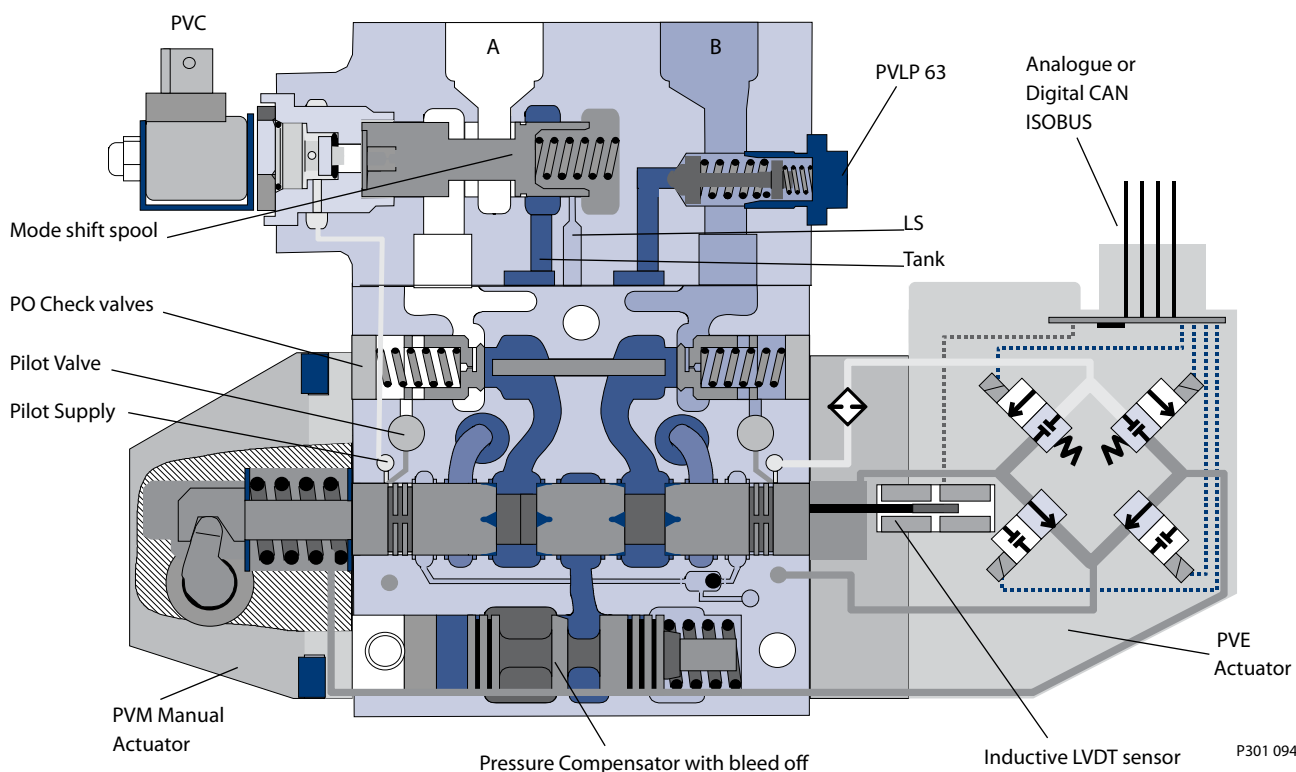

PVBZ-HD parameters

Maximum pressure	Port P continuous	250 bar [3625 psi]
	Port A/B	280 bar [4061 psi]
Oil flow, rated	Port A/B, with press. comp.	100 l/min [26.4 US gal/min]
Pilot oil consumption	PVC off / PVC on	0 / 0.3 l/min

PVG 32 hitch control valves

PVBZ-HD parameters (continued)

Environmental specifications	Temperature oil viscosity etc.	See PVBZ basic module for EH auxiliary valve functions on page 9
PVC solenoid (NC)	Connector type Zener diode included	AMP JPT 2 Pin

PVP with integrated HPCO

Together with the introduction of PVBZ (and PVB with separate tank line T0), Danfoss can now also supply PVG 32 valves with integrated HPCO functionality (High Pressure Carry Over).

The HPCO function will guide the pump flow not used in the PVG 32 valve group via the HPCO port to for example a directional valve. The PVP pump side module with integrated HPCO function can only be mixed with PVB, PVBZ and PVST.

Features:

- HPCO functionality
- Prioritized flow for PVG 32
- Reduced plumbing

Modules and code numbers

PVP, inlet basic modules

PVP, inlet basic modules

Symbol	Descriptions: PVP / PVPV	Ports	Code number
<p>P301 032</p>	<p>PVP, Open centre pump side module for pumps with fixed displacement. External T0. With pilot supply for electrical actuation.</p>	<p>P: M27x2 T: M27x2 M: M14x1.5 LS: M14x1.5 T0: M14x1.5</p>	<p>11072195 (ISO 6149)</p>
<p>P301 033</p>	<p>PVP, Open centre pump side module for pumps with fixed displacement. External T0. With pilot supply for electrical actuation. Prepared for HPCO - use Tport. PVG group requires PVST (end plate with T port).</p>	<p>P: M27x2 T: M27x2 (HPCO) M: M14x1.5 LS: M14x1.5 T0: M14x1.5</p>	<p>157B5961 (ISO 6149)</p>
<p>P301 034</p>	<p>PVP, Open centre pump side module for pumps with fixed displacement External T0 With pilot supply for electrical actuation. Measure port for pilot supply.</p>	<p>P: M22x1.5 P2: M16x1.5 T: M22x1.5 M: M10x1 LS: M12x1.5 T0: M16x1.5 Ppilot: M10x1</p>	<p>157B5964 (DIN 3851)</p>
<p>P301 035</p> <p>Inlet PVP 157B5965 w. HPCO</p>	<p>PVP, Open centre pump side module for pumps with fixed displacement. External T0. With pilot supply for electrical actuation. Prepared for HPCO - use Tport. PVG group requires PVST (end plate with T port).</p>	<p>P: M22x1.5 P2: M16x1.5 T: M22x1.5 (HPCO) M: M10x1 LS: M12x1.5 T0: M16x1.5 Ppilot: M10x1</p>	<p>157B5965 (DIN 3851)</p>
<p>P301 036</p>	<p>PVPV, Closed centre pump side module for pumps with variable displacement. External T0. With pilot supply for electrical actuation. Prepared for PVLP.</p>	<p>P: M33x2 T: M33x2 T2: M14x1.5 M: M14x1.5 LS: M14x1.5 T0: M16x1.5</p>	<p>157B5969 (ISO 6149)</p>
<p>P301 037</p>	<p>PVPV, Closed centre pump side module for pumps with variable displacement. External T0. With pilot supply for electrical actuation.</p>	<p>P, T: M27x2 P2, T2: M14x1.5 LS: M14x1.5 T0, T02: M14x1.5</p>	<p>11003806 (ISO 6149)</p>
<p>V310061.A</p>	<p>PVPV, Closed centre pump side module for pumps with variable displacement. External T0 without pilot supply.</p>	<p>P: M27x2 P2: M14x1.5 T: M27x2 T2: M14x1.5 LS: M14x1.5 T0: M16x1.5 T02: M14x1.5</p>	<p>11055758 (ISO 6149)</p>

Modules and code numbers

PVB, work basic modules

Symbol	Descriptions: PVB	Ports	Code number
<p>P301 038</p>	<p>PVB, With compensator, without thermal relief valve T0 facility LS a/b shuttle valve Prepared for PVLP shock valves</p>	M22 x 1.5	157B6850 (ISO 6149)
<p>P301 039</p>	<p>PVB, With compensator T0 facility LS a/b shuttle valve Prepared for manifold PVBD</p>	Manifold PVBD	157B6969

PVBZ auxiliary modules

PVBZ auxiliary modules

Symbol	Description PVB / PVBZ	Port	Code number
<p>P301 040</p>	<p>PVBZ as PVB Compensator w. bleed off and check valve T0 facility LS a/b shuttle valve Without thermal relief valve</p>	M22 x 1.5	157B6955 (ISO 6149)
<p>P301 041</p>	<p>PVBZ 2 PO check valves Compensator w. bleed off and check valve T0 facility LS a/b shuttle valve. Shuttle pin. Without thermal relief valve</p>	M22 x 1.5	157B6957 (ISO 6149)
<p>P301 042</p>	<p>PVBZ 2 PO check valves. Compensator w. bleed off and check valve T0 facility LS a/b shuttle valve. Shuttle pin. Without thermal relief valve</p>	M22 x 1.5	11024817 (DIN 3851)
<p>P301 043</p>	<p>PVBZ 2 PO check valves. Compensator w. bleed off and check valve T0 facility LS a/b shuttle valve. Shuttle pin. With thermal relief valve</p>	M22 x 1.5	157B6954 (ISO 6149)

Modules and code numbers

PVBZ auxiliary modules (continued)

Symbol	Description PVB / PVBZ	Port	Code number
<p>P301 044</p>	PVBZ 2 PO check valves. Shuttle pin. Compensator w. bleed off and check valve T0 facility LS a/b shuttle valve, LS return With thermal relief valve	Manifold PVBZ	157B6958
<p>P301 045</p>	PVBZ 2 PO check valves. Shuttle pin. Compensator w. bleed off and check valve T0 facility LS a/b shuttle valve, LS return Quick coupler block manifold	Manifold Special interface	11005475

PVBZ-HS/-HD modules, PVBZ diverter, multi-valve (for PVBZ-HD)

PVBZ-HS/-HD modules

Symbol	Description PVBZ	Port	Code number
<p>P301 046</p>	PVBZ-HS with PO Check valve in B port. Compensator w. bleed off and check valve T0 facility Valve for 3/3 spool - single acting only! B-port prepared for PVLP Own T port - enables lowering of no loaded actuator.	M22 x 1.5	157B6968 (ISO 6149)
<p>P301 047</p>	PVBZ with PO check valves. Compensator w. bleed off and check valve T0 facility LS a/b shuttle valve; LS return; Shuttle pin manifold for multi-valve for PVBZ-HD	manifold for multi-valve	11032961

Modules and code numbers

PVBD diverter, multi-valve (for PVBZ-HD)

Symbol	Description	Port	Code Number
	<p>PVBD 6/2 shift valve. Valve shifts between A1 & B1 / A2 & B2. Actuated with included PVC solenoid; PVC NC; 12 V_{DC}; 14 bar. Port max. pressure: 280 bar Connector type: AMP JPT 2 PIN</p>	M22 x 1.5	157B1501 (ISO 6149)
	<p>Multi-valve for PVBZ 11032961 Valve shifts A-port between PVBZ A or tank gallery, i.e. shifts between single and double acting actuation. B-port prepared for PVLV Actuated with included PVC solenoid; PVC NC; 12 V_{DC}; 14 bar. Port max. pressure: 280 bar Connector type: AMP JPT 2 PIN</p>	M22 x 1.5	11027604 (ISO 6149)

PVBS spools

PVBS spools

Symbol	Description PVBS	Pressure compensated flow l/min					
		5 [1.32]	10 [2.64]	25 [6.6]	40 [10.57]	65 [17.17]	100 [22]
	<p>Standard FC-spools for PVBZ (Electrical and Mechanical actuation) Tension bar for PVM Check valves in spool 4-way, 3-position Deadband: 0,8 mm For PVBZ with LS A/B shuttle</p>	11051945	11019630	11019631	11019633	11019634	11019635
	<p>Standard FC-spools for PVBZ and PVBZ-HD (Electrical and Mechanical actuation) Tension bar for PVM Check valve in spool 4-way, 4-position Float >A>F Deadband: 0,8 mm For PVBZ with LS A/B shuttle</p>	157B9415	157B9410	157B9411	157B9412	157B9413	157B9414

Modules and code numbers

PVBS spools (continued)

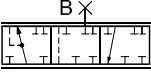
Symbol	Description PVBS	Pressure compensated flow l/min					
		5 [1.32]	10 [2.64]	25 [6.6]	40 [10.57]	65 [17.17]	100 [22]
 157-635.11	Standard FC float spools for PVBZ (Electrical actuation) Tension bar for PVML Check valve in spool 4-way, 4-position Float >A>F Deadband: 0,8 mm For PVBZ with LS A/B shuttle						157B9434
P -> B / B -> T					50/30	75/50	100/65
 B X T P T 157-29.10	Standard FC spools for PVBZ-HS (Electrical and Mechanical actuation) Tension bar for PVM 3-way, 3-position Deadband: 0,8 mm				11023550	11023551	11023552

Activation characteristics

Characteristic of oil flow, spool travel and voltage

- The spools have 5.5 mm spool travel in direction B and 7.5 mm travel in direction A:
- 5.5 mm spool displacement in direction A gives max. oil flow to port A
- 5.5 mm spool displacement in direction B gives max. oil flow to port B
- 7.5 mm spool displacement in direction A gives completely open float position A/B → T

Characteristic of oil flow, spool travel and voltage

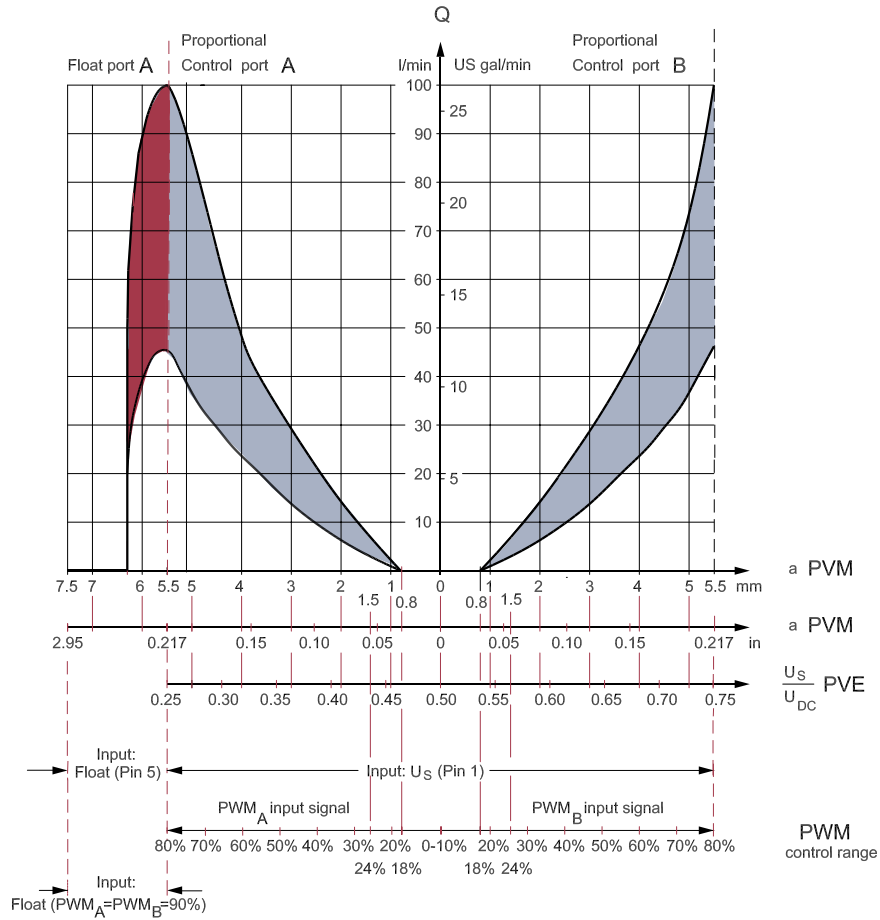

a PVM

a PVM

$\frac{U_S}{U_{DC}}$ PVE

PWM control range

157-532.12

Pressure drop characteristics

Pressure drop characteristics of float spools

A/B → T at max. spool travel 5.5 mm (A or B) or 7.5 mm float position. Shown curves are typical average values of return pressure drops on 1. Position in a PVBZ module (157B5957) to the T-port (M27) on a PVPV inlet.

Pressure drop A/B → T characteristic for PVBS: 157B9414 and 157B9434

Pressure drop A/B to T : PVBS 157B9414 & 157B9434

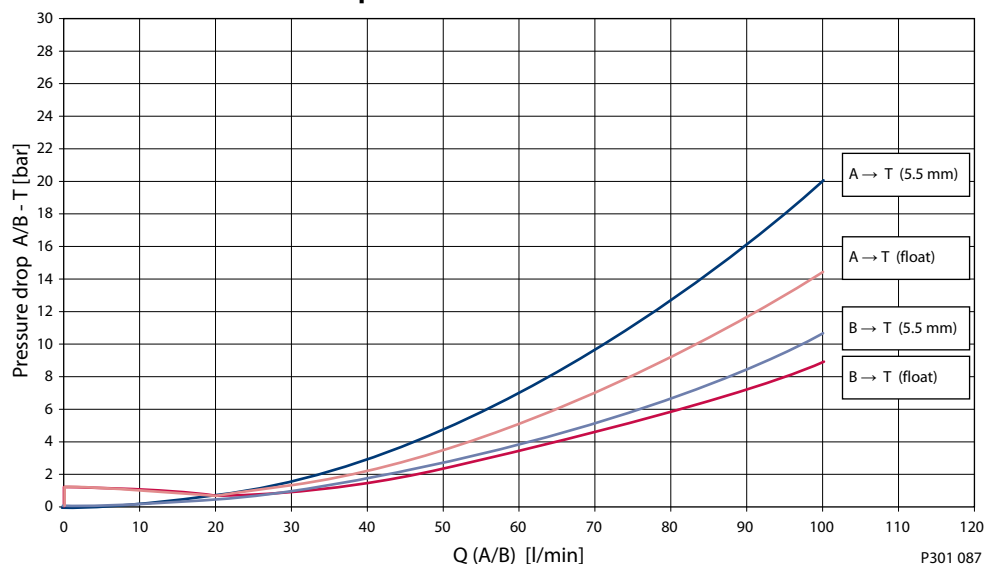

Pressure drop A/B → T characteristic for PVBS: 157B9413

Pressure drop A/B to T : PVBS 157B9413

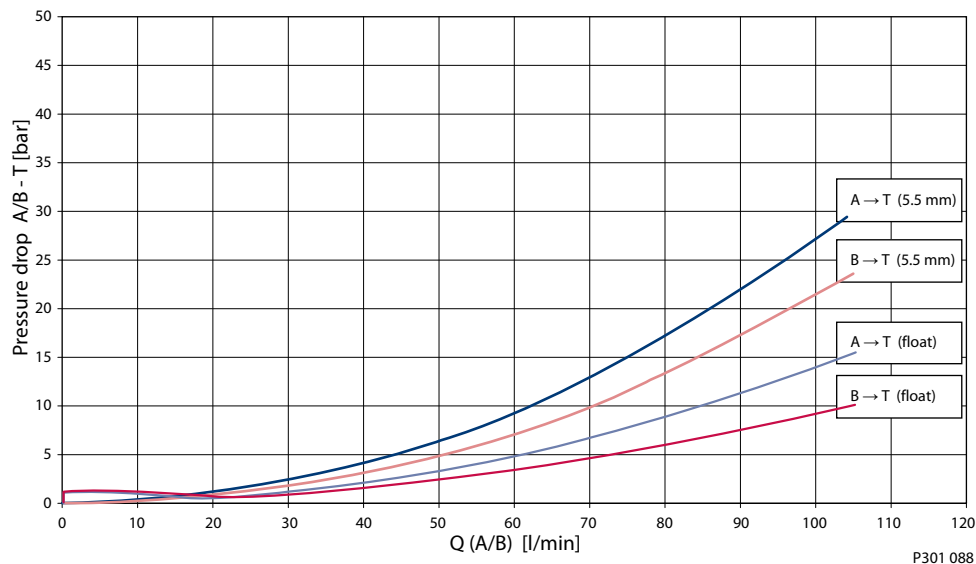

Pressure drop characteristics

Pressure drop A/B → T characteristic for PVBS: 157B9642

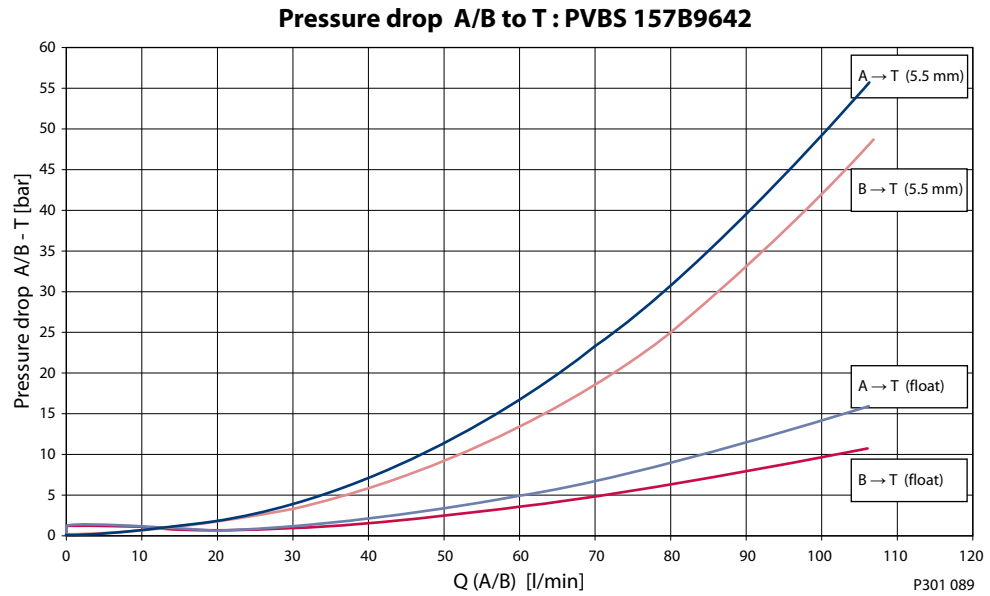

Pressure drop A/B → T characteristic for PVBS: 157B9411

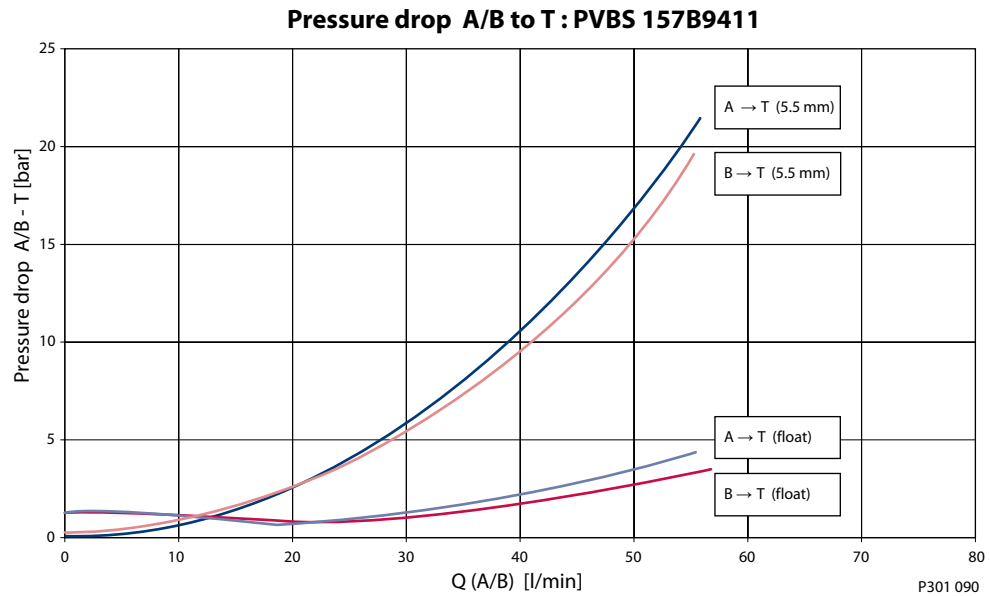

Pressure drop characteristics

Pressure drop A/B → T characteristic for PVBS: 157B9410

Pressure drop A/B to T : PVBS 157B9410

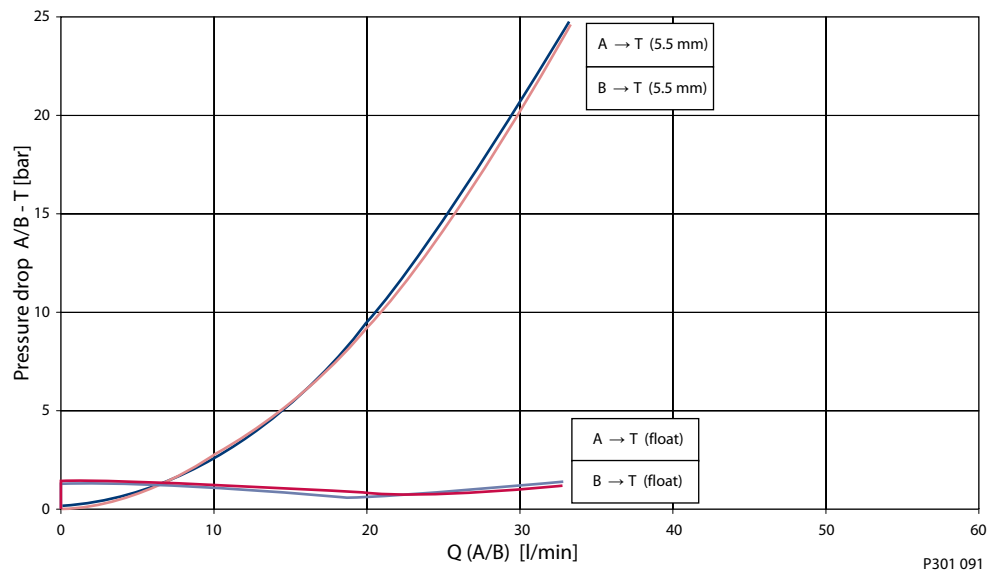

P301 091

Pressure drop A/B → T characteristic for PVBS: 157B9415

Pressure drop A/B to T : PVBS 157B9415

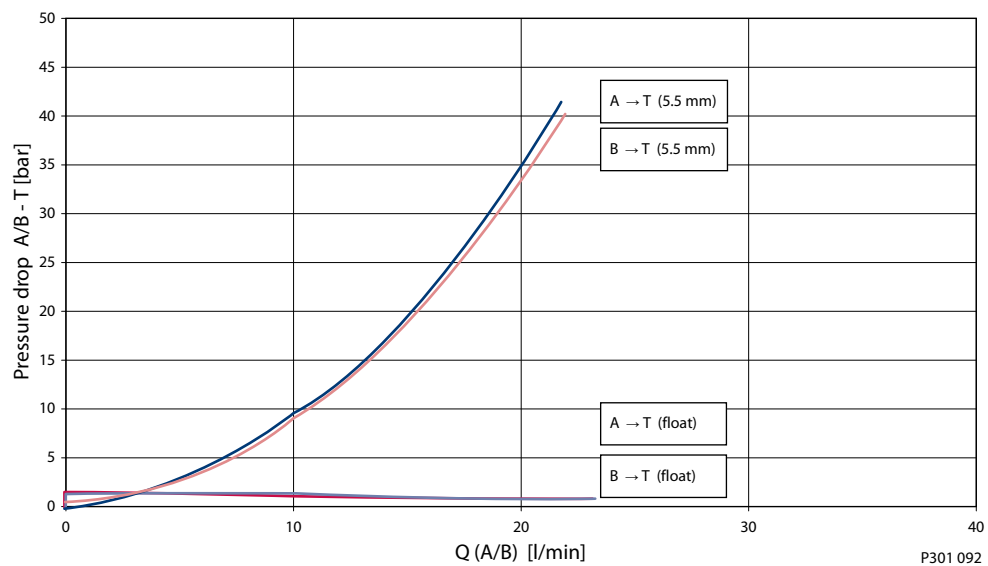

P301 092

Pressure drop characteristics

Single acting spools characteristics for PVBZ-HS

3/3 spools characteristic for PVBZ-HS 157B9411 Oil flow, spool travel and voltage

**3/3 spools for PVBZ-HS
 Characteristics; Oil flow, spool travel and voltage**

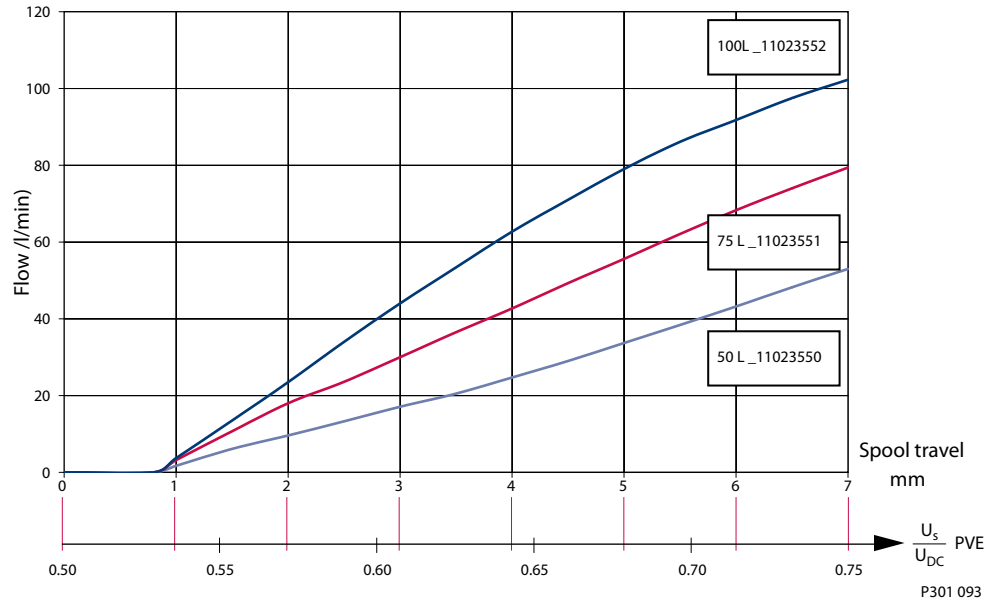

B → T at max. spool travel 7.0 mm. Shown curves are typical average values of return pressure drops on 1. Position in a PVBZ_HS module to the T-port (M27) on a PVPV inlet.

Pressure drop characteristic in lower mode position, max. spool travel

Pressure drop B → T characteristic for PVBS 11023550, 11023551 and 11023552

Pressure drop B to T: PVBS 11023550, 11023551 & 11023552

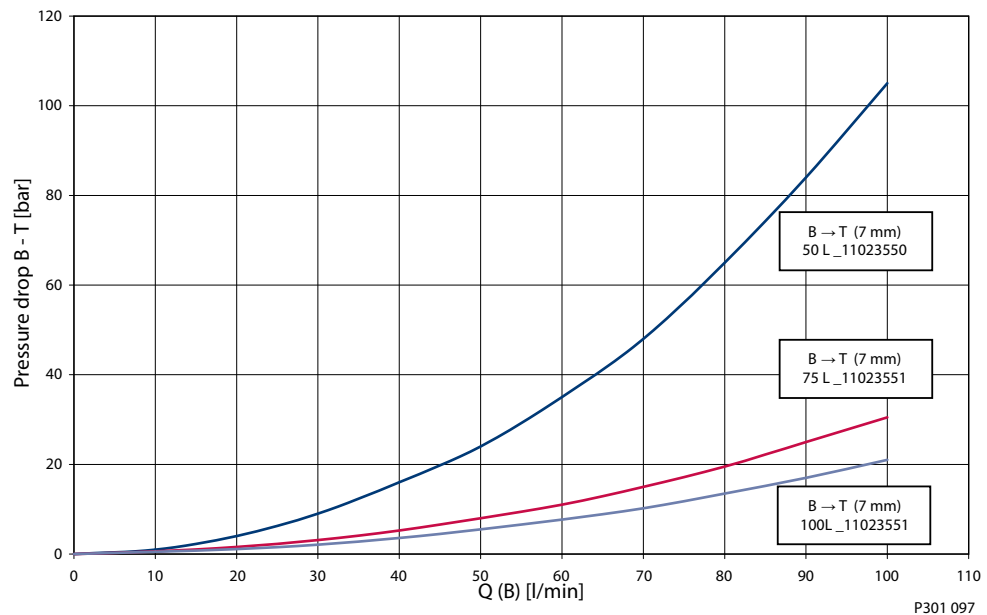

Pressure drop characteristics

Spools characteristics for PVBZ-HD

Normally float spools as for PVBZ basic modules are recommended for the PVBZ-HD solution. See Activation characteristics.

Pressure drop characteristics for the PVBZ-HD valve are shown in the following example using a 100l float spool code no.: 157B9414 at the respective spool travel and multi-valve mode position.

Shown curves are typical average values of return pressure drops on 1. Position in a PVBZ-HD module to the T-port (M27) on a PVPV inlet.

Pressure drop B → T characteristic for PVBS 157B9414; PVBZ-HD double acting mode

Pressure drop B to T - PVBS 157B9414 PVBZ-HD Double acting mode

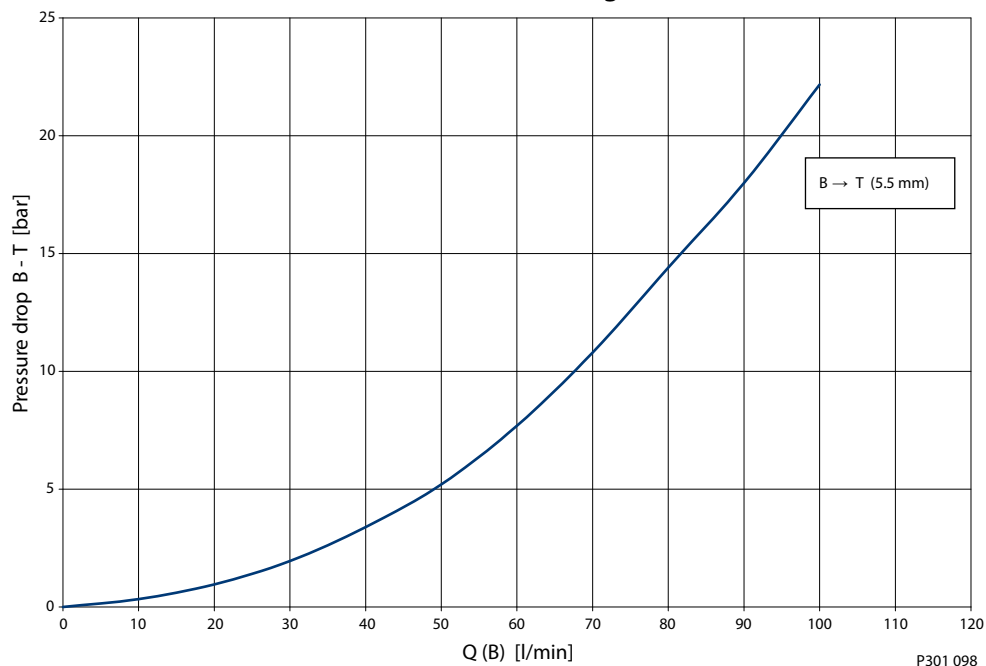

Pressure drop characteristics

Pressure drop A → T characteristic for PVBS 157B9414; PVBZ-HD double acting mode

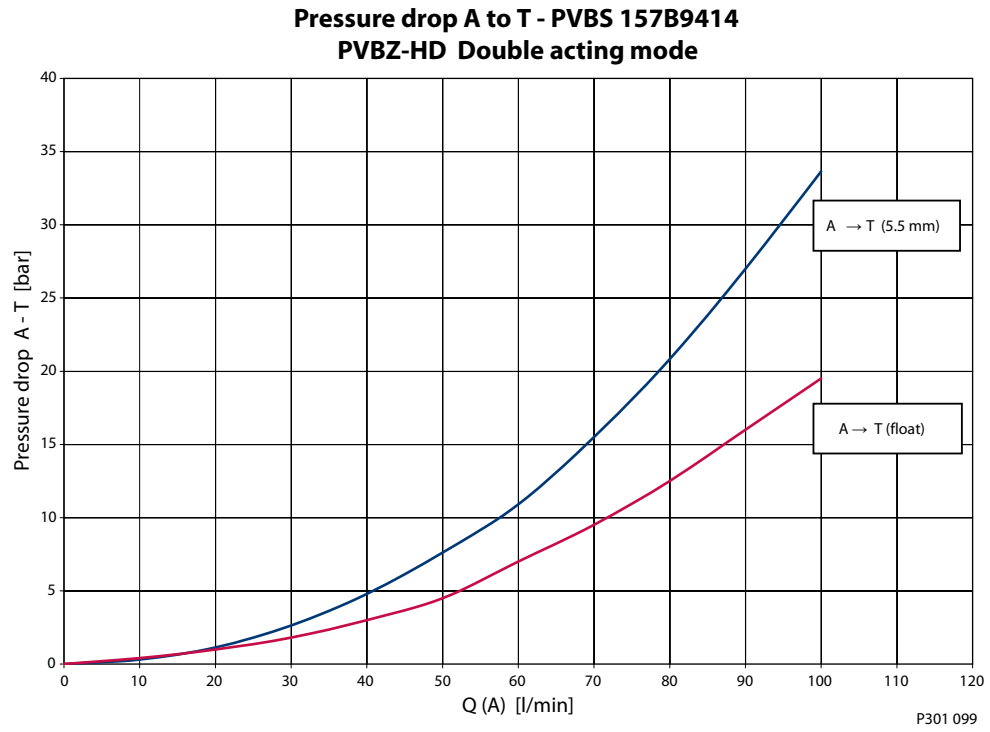

Pressure drop A → T characteristic; PVBZ-HD single acting mode

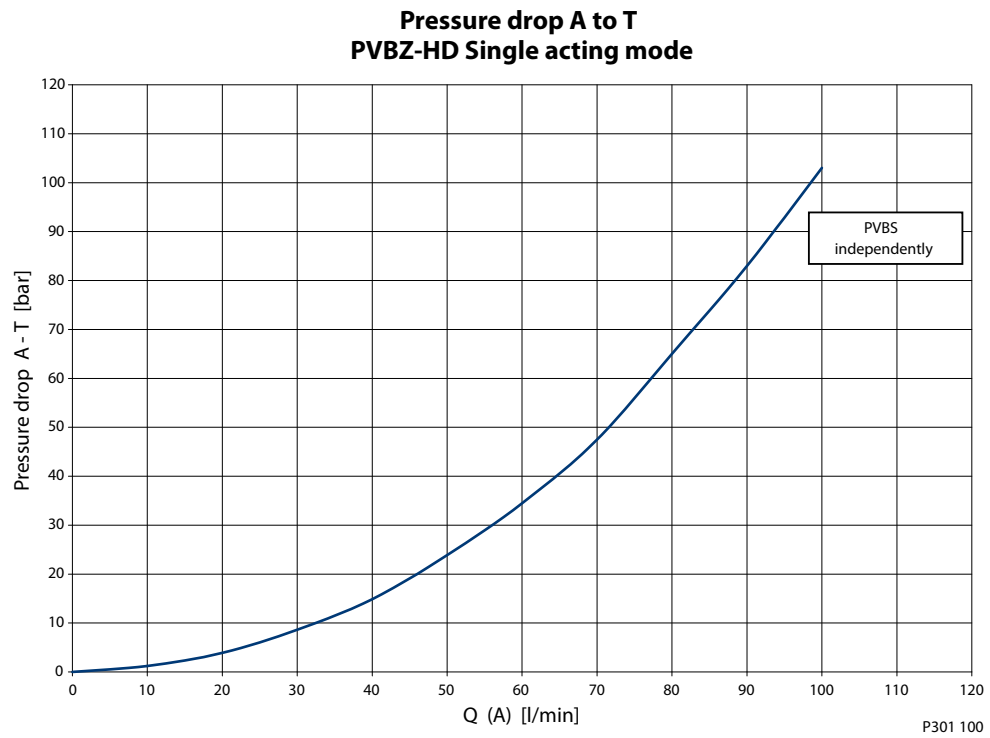

Dimensions and schematics

Drawings for 5-section group

- Example of PVG 32: 5 sections valve group with 1 double acting hitch (PVBZ-HD), with 1 aux. valve PVBZ with PVBD diverter valve slice, 2 aux. valves PVBZ and 1 aux. valve PVB.
- To be supplied with LS variable piston pump.
- PVED-CC with APM-JPT connector.

Example of PVG 32: 5 sections valve group with 1 double acting hitch (PVBZ-HD), with 1 PVBZ with PVBD diverter, 2 PVBZ, 1 PVB

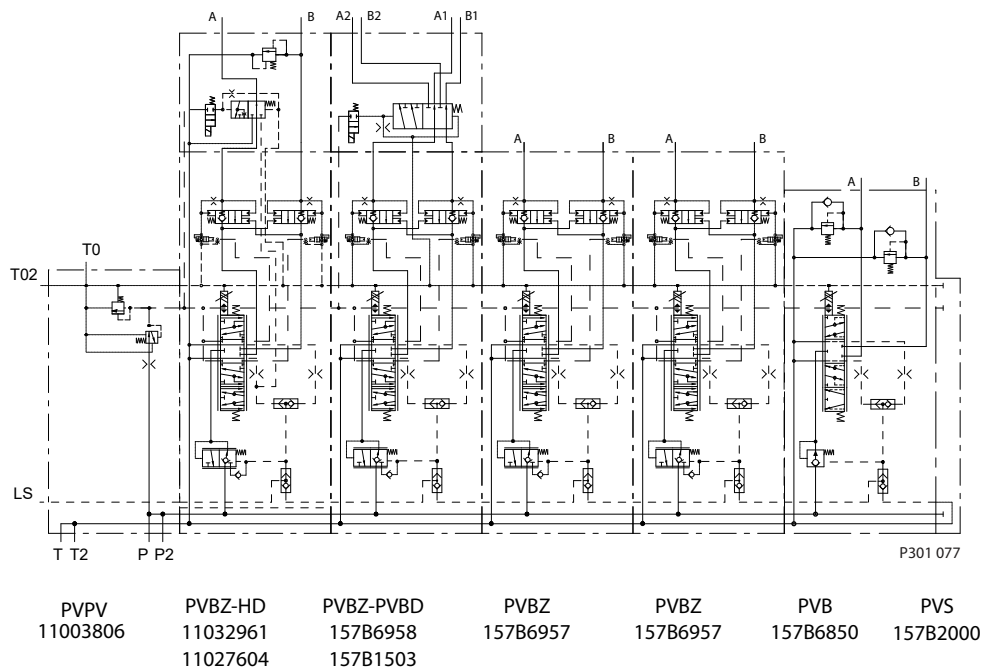

Dimensions and schematics

Drawing for 5-section valve group

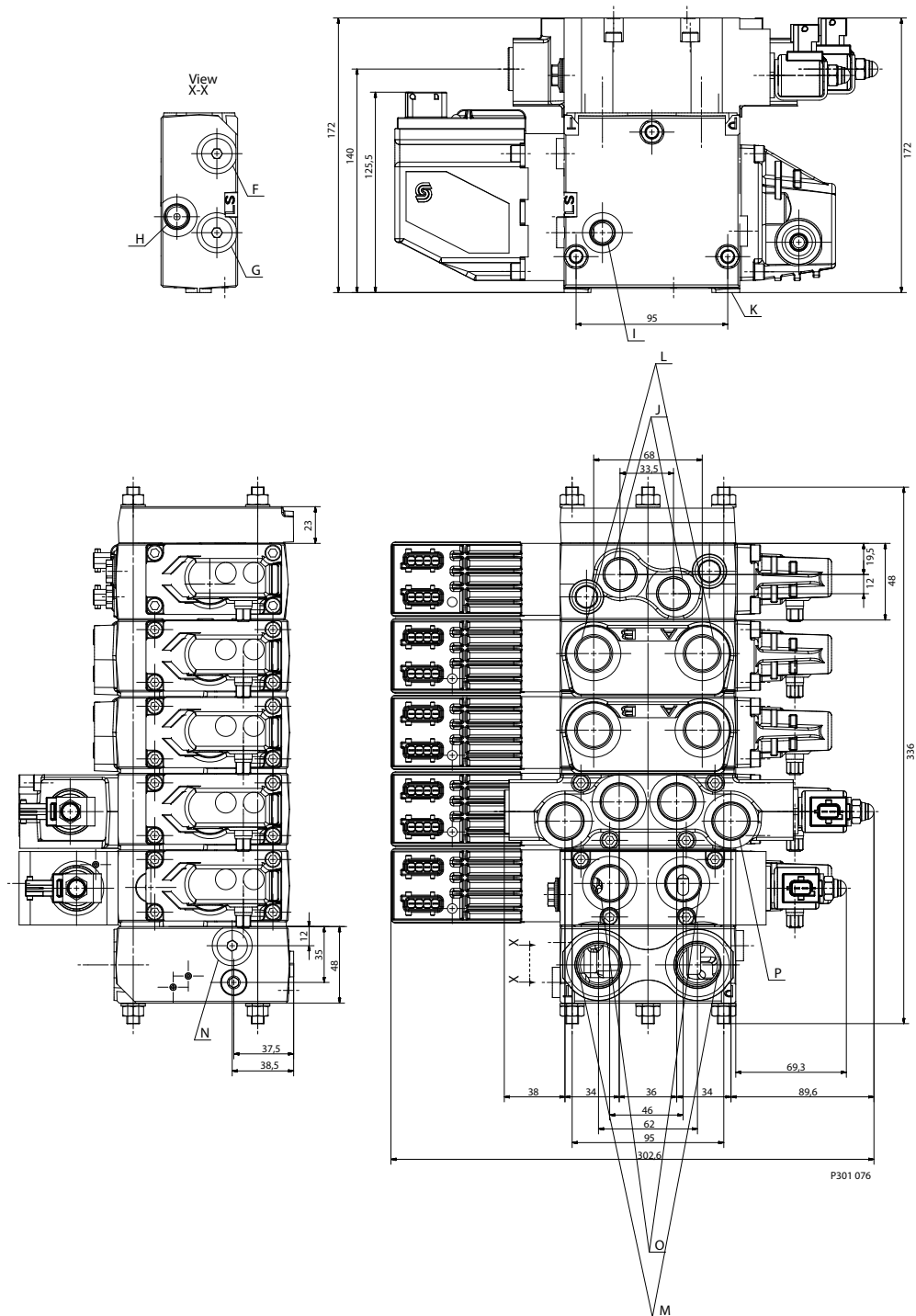

F: Port T2; M14 x 1.5
 G: Port T0; M14 x 1.5
 H: Port LS; M14 x 1.5
 I: Port T02; M14 x 1.5
 J: PVB A and B port; M22 x 1.5
 K: Fixing holes; M8 x min. 10

L: PVBZ A and B port; M22 x 1.5
 M: Port P and T; M27 x 2.0
 N: Port P2; M14 x 1.5
 O: PVBZ-HD work port; M22 x 1.5
 P: PVBD work port; 4 x M22 x 1.5

Dimensions and schematics

Drawings for 3-section group

- Example of PVG 32: 3 section valve group, with 1 hitch single acting (PVBZ-HS) and 2 aux. valve slices.
- To be supplied with LS variable piston pump.
- PVED-CC with Deutsch DT connector.

Example of PVG 32: 3 sections valve group with 1 single acting hitch (PVBZ-HS) and 2 aux. valve slices.

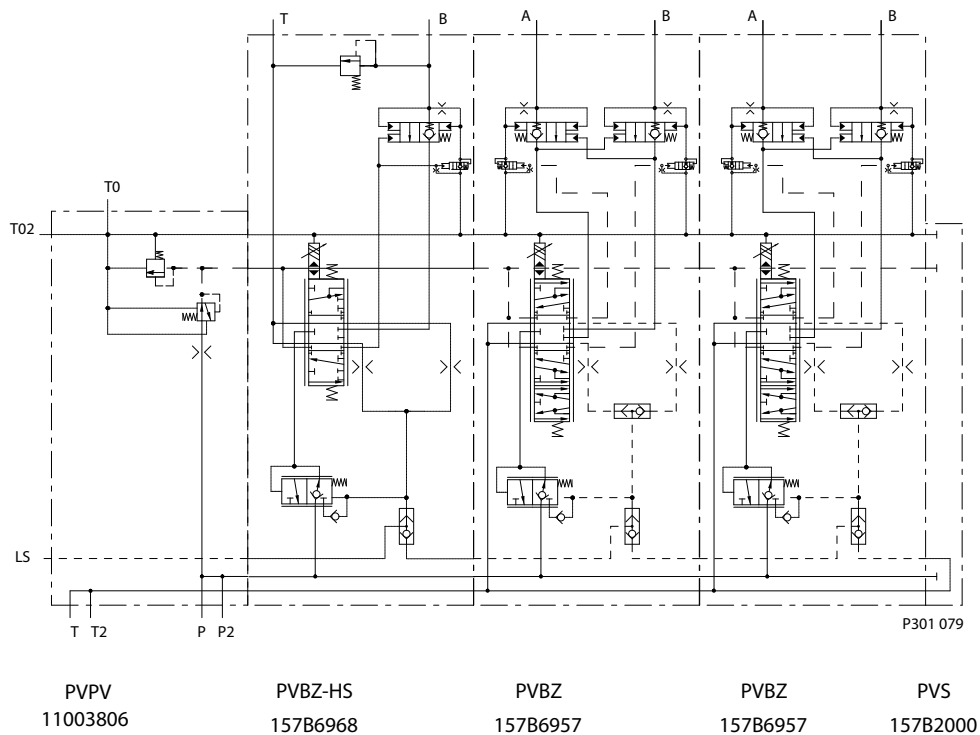

Dimensions and schematics

Drawing for 3-section valve group

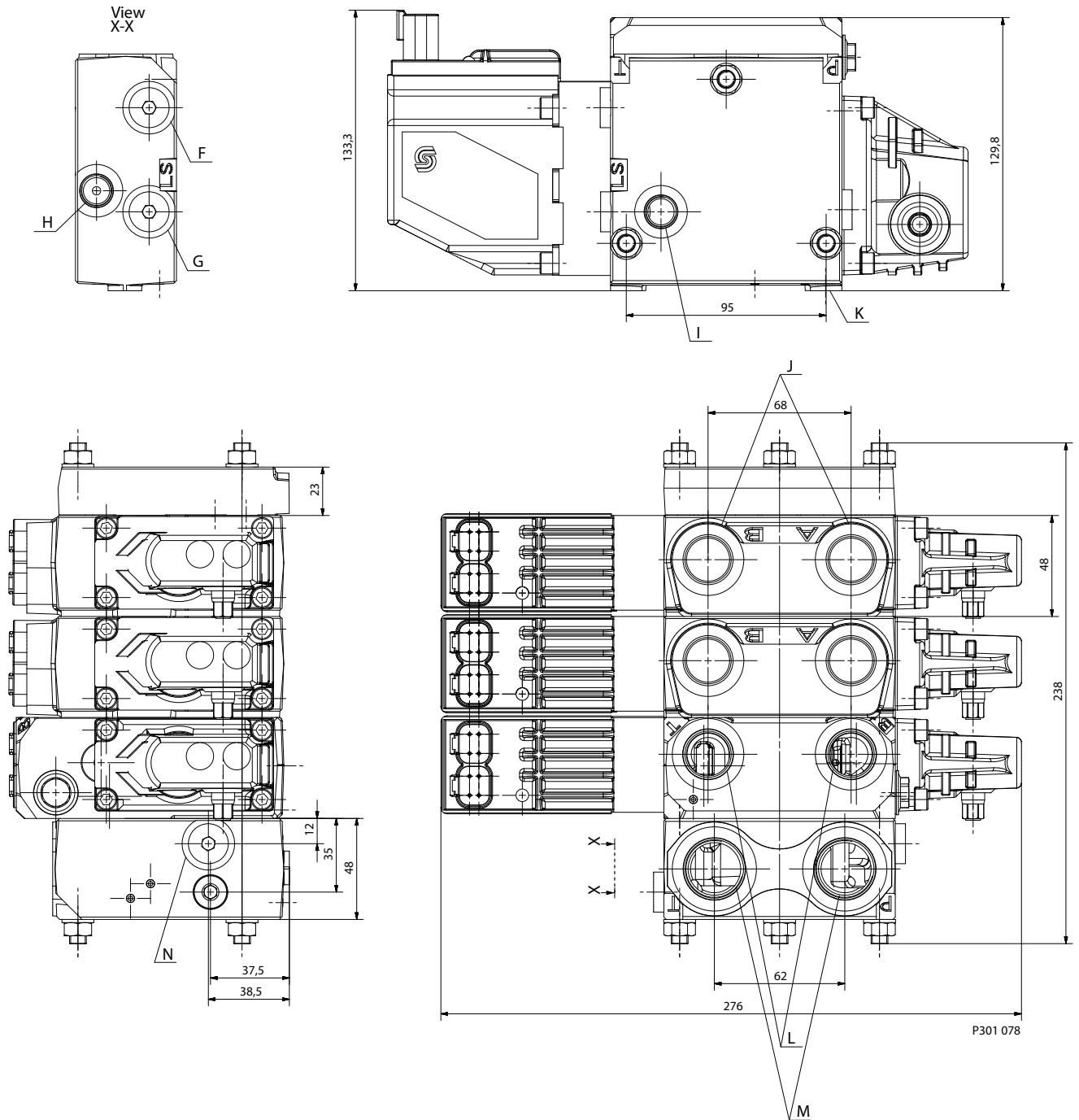

P301 078

- F: Port T2; M14 x 1.5
- G: Port T0; M14 x 1.5
- H: Port LS; M14 x 1.5
- I: Port T02; M14 x 1.5
- J: PVB A and B port; M22 x 1.5

- K: Fixing holes; M8 x min. 10
- L: PVBZ-HS work port B and T; M22 x 1.5
- M: Port P and T; M27 x 2.0
- N: Port P2; M14 x 1.5

Dimensions and schematics

Drawings for 2-section group

- PVG 32: 2 section valve group, typical example for Loader application for tractors.
- To be supplied with fixed pump.
- The PVP inlet has HPCO feature, consequently the PVT has tank port.
- PVED-CC with APM-JPT connector.

Example of PVG 32: 2 section valve group, typical example for Loader application for tractors.

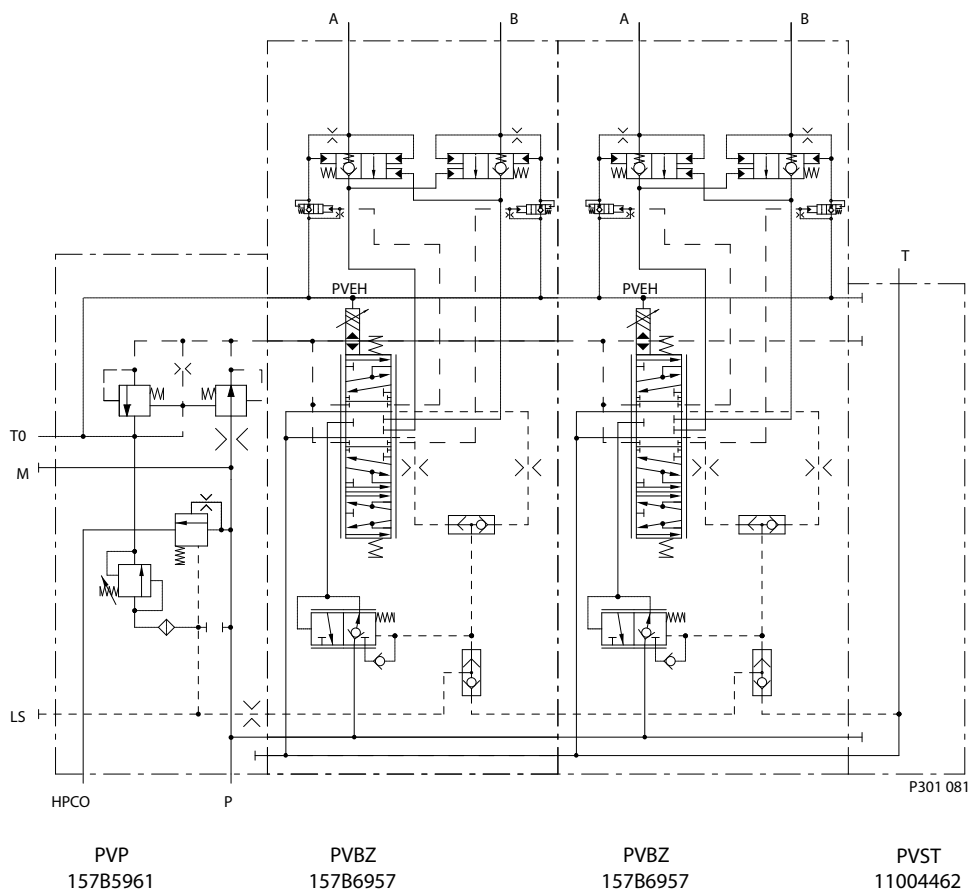

Dimensions and schematics

Drawing for 2-section valve group

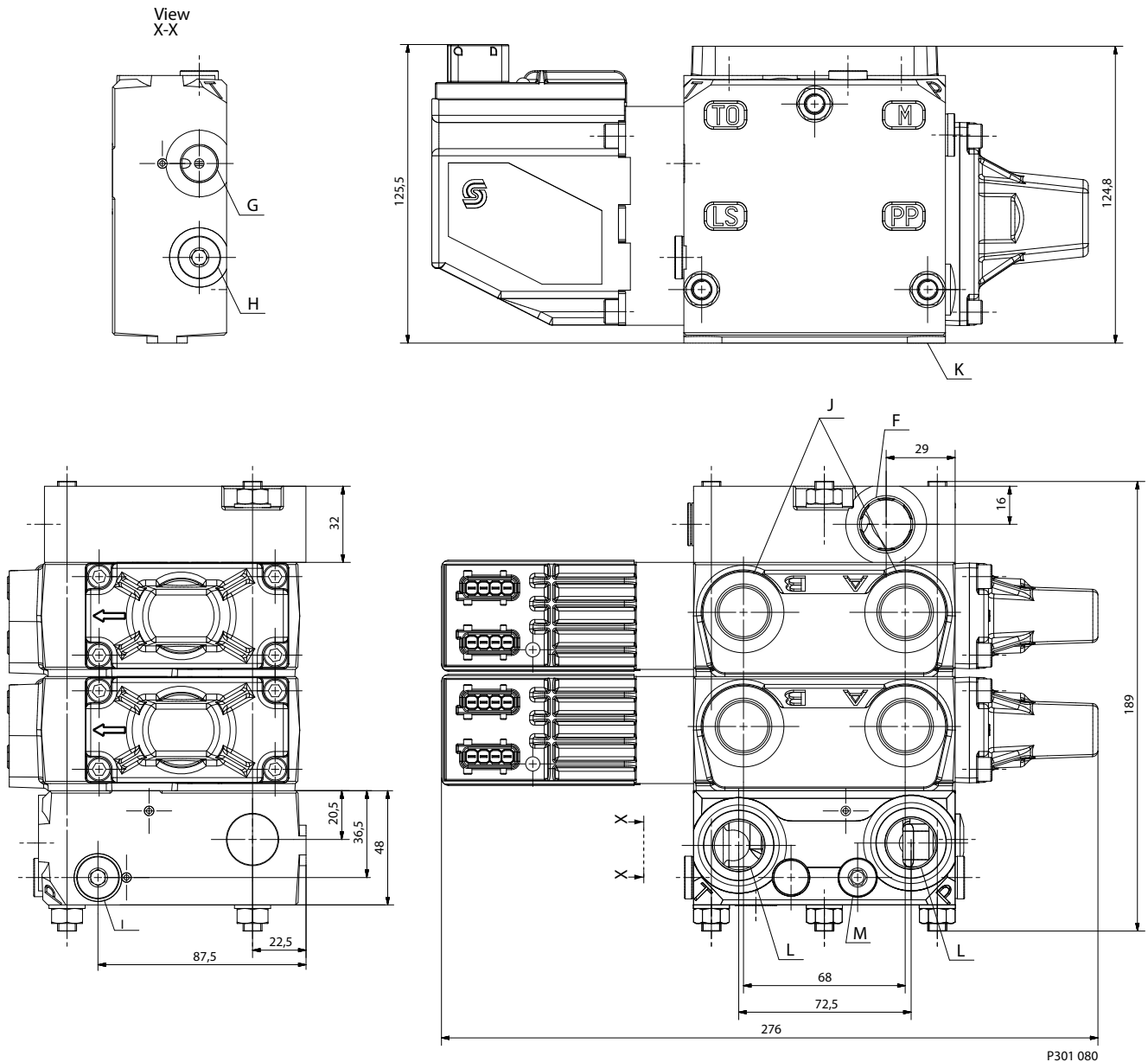

F: Port T; M22 x 1.5
 G: Port T0; M14 x 1.5
 H: Port LS; M14 x 1.5
 I: Port M gauge; M14 x 1.5

J: Port A and B; M22 x 1.5
 K: Fixing holes; M8 x min. 10
 L: Port P & HPCO; M27 x 2.0
 M: Pressure relief valve

Products we offer:

- Cylinders
- Electric converters, machines, and systems
- Electronic controls, HMI, and IoT
- Hoses and fittings
- Hydraulic power units and packaged systems
- Hydraulic valves
- Industrial clutches and brakes
- Motors
- PLUS+1® software
- Pumps
- Steering
- Transmissions

Danfoss Power Solutions designs and manufactures a complete range of engineered components and systems. From hydraulics and electrification to fluid conveyance, electronic controls, and software, our solutions are engineered with an uncompromising focus on quality, reliability, and safety.

Our innovative products makes increased productivity and reduced emissions a possibility, but it's our people who turn those possibilities into reality. Leveraging our unsurpassed application know-how, we partner with customers around the world to solve their greatest machine challenges. Our aspiration is to help our customers achieve their vision — and to earn our place as their preferred and trusted partner.

Go to www.danfoss.com or scan the QR code for further product information.

**Hydro-Gear**

www.hydro-gear.com

Daikin-Sauer-Danfoss

www.daikin-sauer-danfoss.com

**Danfoss
Power Solutions (US) Company**
2800 East 13th Street
Ames, IA 50010, USA
Phone: +1 515 239 6000

**Danfoss
Power Solutions GmbH & Co. OHG**
Krokamp 35
D-24539 Neumünster, Germany
Phone: +49 4321 871 0

**Danfoss
Power Solutions ApS**
Nordborgvej 81
DK-6430 Nordborg, Denmark
Phone: +45 7488 2222

**Danfoss
Power Solutions Trading
(Shanghai) Co., Ltd.**
Building #22, No. 1000 Jin Hai Rd
Jin Qiao, Pudong New District
Shanghai, China 201206
Phone: +86 21 2080 6201

Danfoss can accept no responsibility for possible errors in catalogues, brochures and other printed material. Danfoss reserves the right to alter its products without notice. This also applies to products already on order provided that such alterations can be made without subsequent changes being necessary in specifications already agreed. All trademarks in this material are property of the respective companies. Danfoss and the Danfoss logotype are trademarks of Danfoss A/S. All rights reserved.