



# Effective and cost-efficient hot gas defrost methods

**Author:**

Niels P Vestergaard, Global Application  
Expert, Industrial Refrigeration,  
Danfoss A/S



## Contents

|           |  |    |
|-----------|--|----|
| <b>01</b> | Introduction .....   | 3  |
| <b>02</b> | Various defrosting methods .....   | 4  |
| 2.1       | Introduction .....   | 4  |
| 2.2       | Defrost methods .....  | 5  |
| 2.3       | Hot gas defrost method .....   | 6  |
| 2.3.1     | Pressure control and Liquid drain defrost systems .....                                    | 6  |
| <b>03</b> | Laboratory and field tests with Pressure control<br>and Liquid drain defrost systems ..... | 8  |
| 3.1       | Laboratory and field tests – Key conclusions .....   | 9  |
| <b>04</b> | Simulation model .....   | 11 |
| 4.1       | Simulation results .....   | 11 |
| <b>05</b> | Danfoss ICFD Defrost Module based on the Liquid drain method .....                         | 14 |
| <b>06</b> | Design requirements .....  | 15 |
| <b>07</b> | Field test .....   | 18 |
| <b>08</b> | Dimensioning mass flow in hot gas defrost lines .....                                      | 19 |
| 8.1       | Dimensioning capacity .....  | 19 |
| 8.2       | Dimensioning quality .....   | 20 |
| 8.2.1     | Liquid drain method .....  | 20 |
| 8.2.2     | Pressure control method .....  | 20 |
| 8.3       | Default dimensioning values .....  | 21 |
| 8.4       | Sizing defrost system – hot gas lines .....  | 21 |
| <b>09</b> | Safety considerations .....  | 22 |
| 9.1       | Design safety considerations .....   | 22 |
| 9.1.1     | Hot gas injection .....  | 22 |
| 9.1.2     | Regulated hot gas pressure .....   | 23 |
| 9.1.3     | Soft opening solenoids for hot gas injection .....   | 23 |
| 9.1.4     | Soft opening solenoids for pressure equalizing<br>at end of defrosting .....               | 24 |
| 9.1.5     | Draining condensate from hot gas lines .....   | 25 |
| <b>10</b> | Bibliography .....   | 26 |
| <b>11</b> | ANNEX: Additional safety considerations .....  | 27 |
| 11.1      | Operation safety considerations .....  | 27 |
| 11.2      | Minimize risk of liquid hammer .....   | 27 |
| 11.3      | Pressure impact caused by Vapour – propelled liquid slug .....                             | 28 |
| 11.4      | Pressure impact caused by Condensation – induced shock .....                               | 29 |

## 01

# Introduction

This White paper describes hot gas defrosting methods for evaporators in industrial systems. The focus in this document is defrosting methods for ammonia air coolers in overfeed systems, especially concentrating on Liquid drain method and its benefits compared to Pressure control method. It also introduces a new defrost solution from Danfoss, leveraging the benefits of the Liquid drain method. Recommendations are provided on how to achieve effective and cost-efficient defrost systems, taking into account key design requirements and safety considerations, ensuring the optimal defrost solution for the industry.



# 02

## Various defrosting methods

### 2.1

#### Introduction

Over time, air coolers in refrigeration systems are covered with ice / rime if they are operating below the freezing point. To ensure that the system is operating efficiently, the evaporator needs to be defrosted.

An effective defrost is a key feature of the system to ensure the overall efficiency of the plant and the product quality. It is also an essential parameter in the total cost of ownership (TCO) of the complete defrost system. For an ideal defrost, all the heat added to defrosting process would be used to melt the ice on the air cooler surface with minimum heating of the coil and its surroundings.

Several elements should be considered, when evaluating the effectiveness of a defrost:

- Ability to remove all ice/rime from the air cooler surface with minimum energy consumption
- Minimum heat transfer into the refrigerated space
- Minimum transfer of moisture from the surface of the air cooler into the refrigerated space
- Minimum flash gas and non-condensed hot gas bypassing (gas blow-by) through the evaporator (gas will flow directly to the compressor for re-compression).
- Electrical energy used in the defrost process
- Defrost cycle duration
- Reliable and safe defrost process



## 2.2 Defrost methods

There is a variety of defrost methods used in industrial refrigeration, but by far the most common one is hot gas defrost. Other methods like electrical defrost and water defrost are also used, but not often (Figure 1). Each have their pros and cons when evaluating the effectiveness and cost.

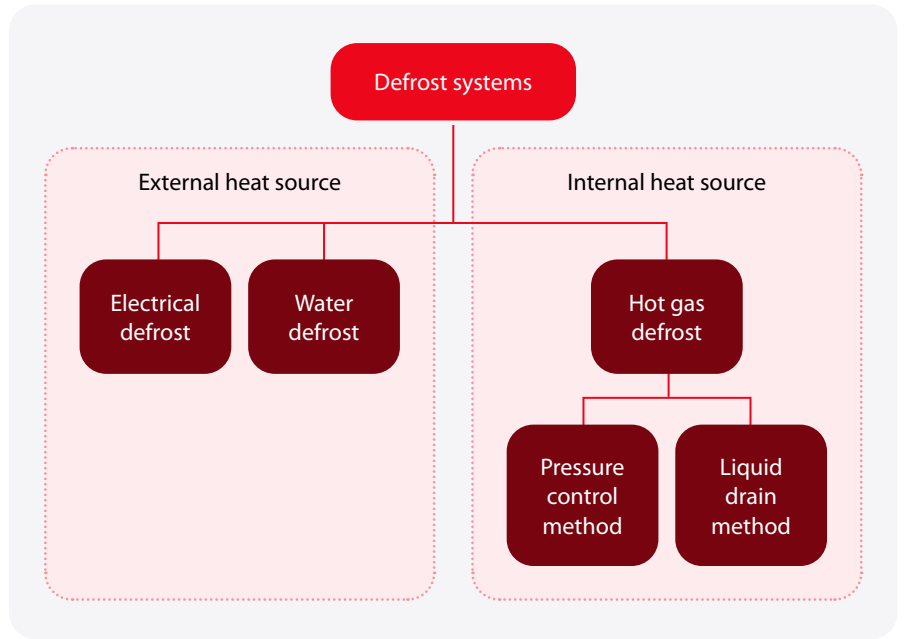

Figure 1: → Common defrost systems

Electrical defrost is the most common defrost method with “external” heat source. From an application point of view, electrical defrost is an easy and attractive solution, but from an operational costs cost point of view it is very expensive – especially for low temperature systems.



## 2.3 Hot gas defrost method

In hot gas defrost the heat is taken from within the refrigeration system as “free energy”. It is important though to select the right method to control the hot gas supply to the evaporator to ensure that energy losses are minimized. Losses are typically coming from flash gas and non-condensed hot gas passing through the evaporator.

### 2.3.1 Pressure control and Liquid drain defrost method

Traditionally, one of the following two methods is used for controlling the hot gas supply to the evaporator:

|  |   |
|--|---|
| <p style="text-align: center;"><b>01</b></p> <h3 style="text-align: center;">Pressure control method</h3> <p>The pressure in the evaporator during defrost is controlled using a valve in the defrost drain line. The Pressure control method is the most commonly used method in the industry, mainly due to the simple design, but the energy loss is a challenge.</p> | <p style="text-align: center;"><b>02</b></p> <h3 style="text-align: center;">Liquid drain method</h3> <p>The condensed liquid is drained from the evaporator using a float valve in the defrost drain line. The Liquid drain method ensures that only liquid refrigerant is drained from the evaporator during the defrost, thereby minimizing noncondensed hot gas flow.</p> |
|--|---|

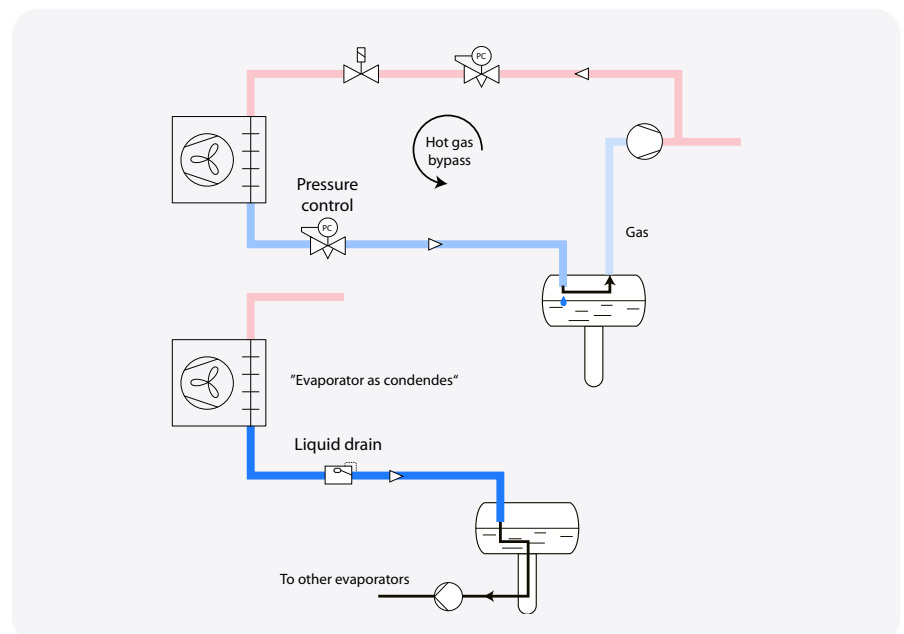

Figure 2: → Pressure control and liquid drain

Comparing the two methods, there is a significant difference in the hot gas consumption. After start-up, the pressure stabilizes to approximately the same pressure for the two methods. However, when using the liquid drain method, only condensate is drained, which means that the mass flow is decreased when the evaporator is heated up, and less hot gas can be condensed. Figure 3 shows the energy distribution of the two control methods:

- +**

Net effective hot gas energy is the amount of energy that is used to heat-up the evaporator and melt the ice from the surface (blue area).
- +**

The convection loss is the amount of energy that is transferred into the surroundings (red area).
- +**

Additional hot gas energy (yellow area).

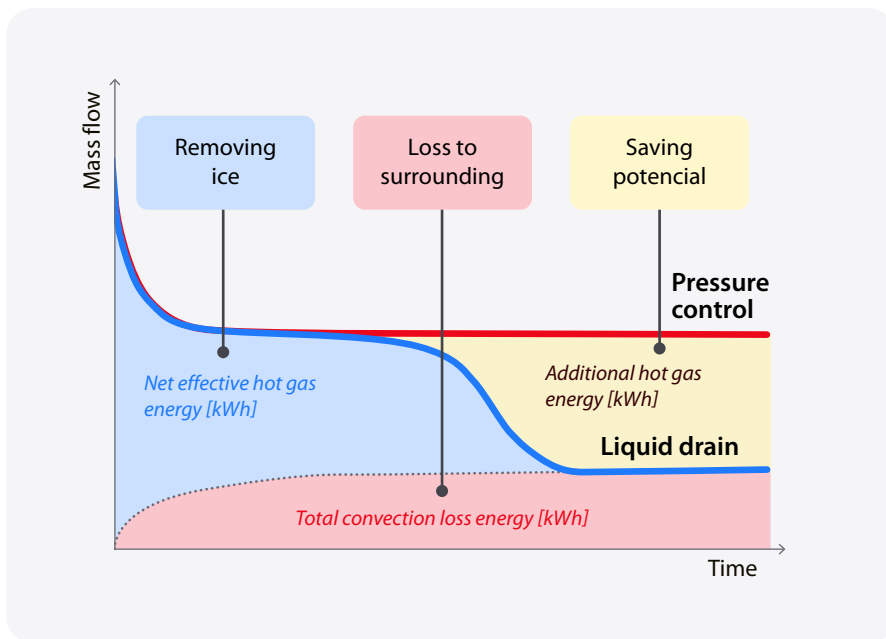

← Figure 3: Example of energy distribution in Pressure control method vs. Liquid drain method

The yellow area in Figure 3 is the additional energy required to recompress non-condensed hot gas passing through the evaporator when using Pressure control method. Using the Liquid drain method, the yellow area represents the energy saving potential. Regardless of which method used, there will be a certain convection loss to the surroundings.

# 03 Laboratory and field tests with Pressure control and Liquid drain methods

Danfoss A/S has participated in a major research project and conducted intensive laboratory and field tests with Pressure control and Liquid drain methods. This includes a series of advanced laboratory tests on an Ammonia pump circulated industrial refrigeration system working under controlled conditions. In the laboratory test it was possible to measure pressure, temperature, mass flow of both refrigerant and water/ice as well as monitoring the defrosting process.

In addition to the laboratory test, three different types of evaporators have been tested using both the Pressure control and the Liquid drain method to control the hot gas supply during defrost. The three evaporator types represent the most common configurations used in the industry: The bottom-

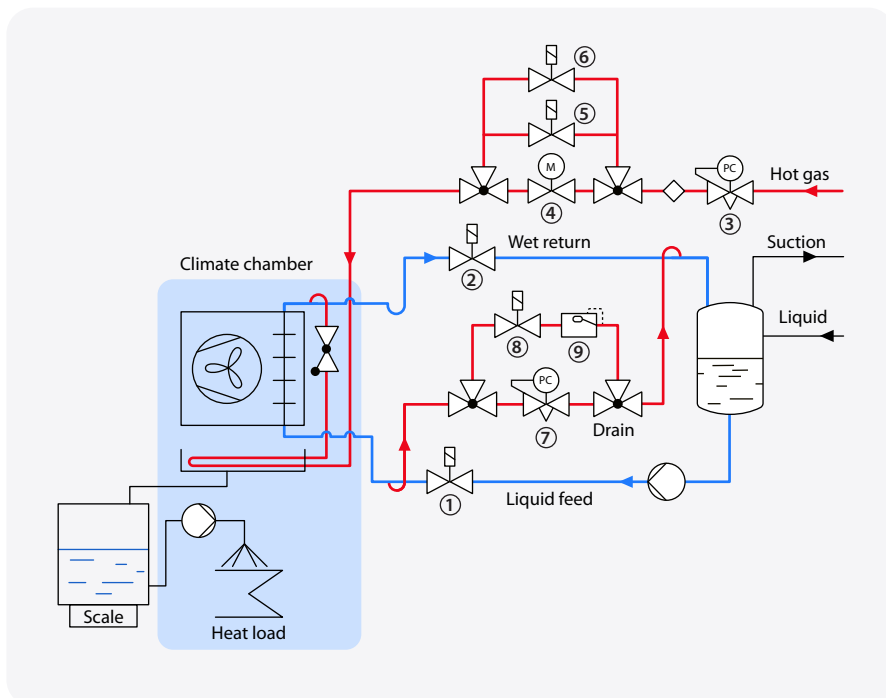

← Figure 4: Principle PI diagram showing of test system

feed evaporators without distribution orifices are very common in Europe, whereas top-feed and side-feed are the most common types in USA. Top-feed evaporators usually have distributions orifices at the inlet, which means that hot gas is injected through the orifices creating additional pressure drop. Side/bottom feed evaporators have distribution orifices in the liquid inlet/condensate drain outlet, which means that Liquid drain during defrost must pass the orifices creating additional flash gas before the drain valve.

↓ Figure 5: Tested evaporator types

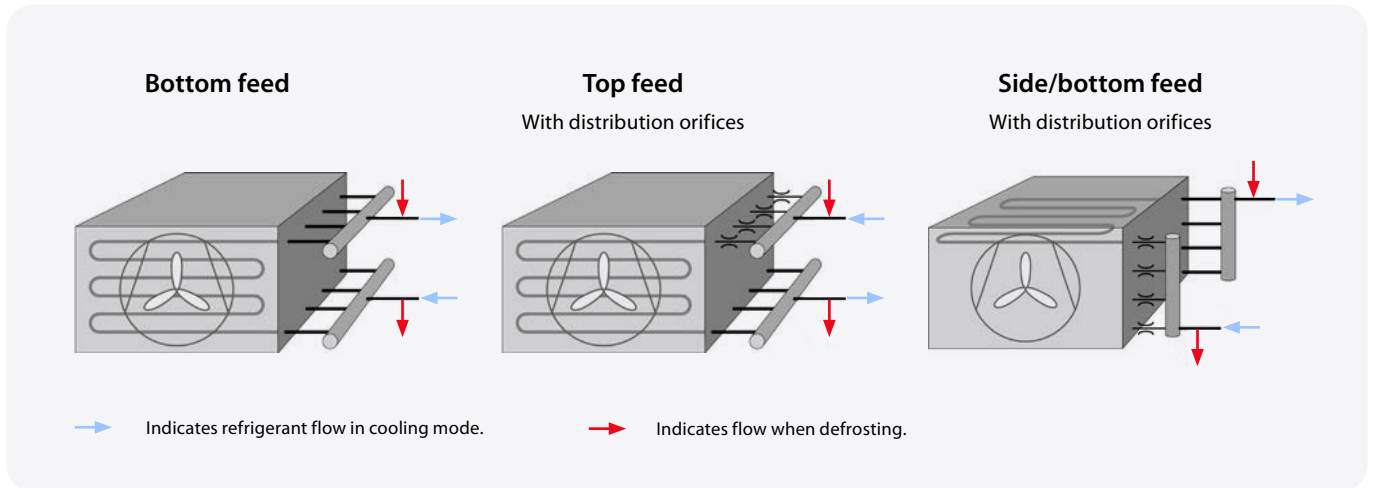

### 3.1 Laboratory and field tests – Key conclusions

All test results clearly demonstrate the advantages of the Liquid drain method over the Pressure control method:

- The Liquid drain method ensures that liquid condensate is drained at the lowest possible pressure, whereas the Pressure control method only drains at pre-set defrost pressure.
- The Liquid drain method guarantees that only liquid condensate is drained. When the hot gas capacity becomes bigger than the required defrost capacity, the Pressure control method will “release” the pressure (liquid and vapour), whereas the Liquid drain method will only drain the condensate.
- The Liquid drain method requires less hot gas to defrost an evaporator, compared with the Pressure control method. This phenomenon is particularly visible if the defrost cycle is longer than needed to remove the ice, illustrated in Figure 3.

→ The three different types of evaporators - bottom-feed, top-feed and side/bottom feed evaporators were defrosted effectively with only minor differences. For bottom-feed and top-feed, the defrost was fast with a uniformed removal of ice from the surface. However, for side/bottom feed evaporators, the ice melting was slightly uneven with minor re-freezing (pieces of ice formed by the freezing of dripping water).

**Important to note:**

All evaporators installed with liquid condensate drain, **must** have bottom mounted drain connection.

Figure 6 shows the measured hot gas mass flow and the accumulated water condensate for the Pressure control and Liquid drain methods respectively for bottom-feed evaporator.

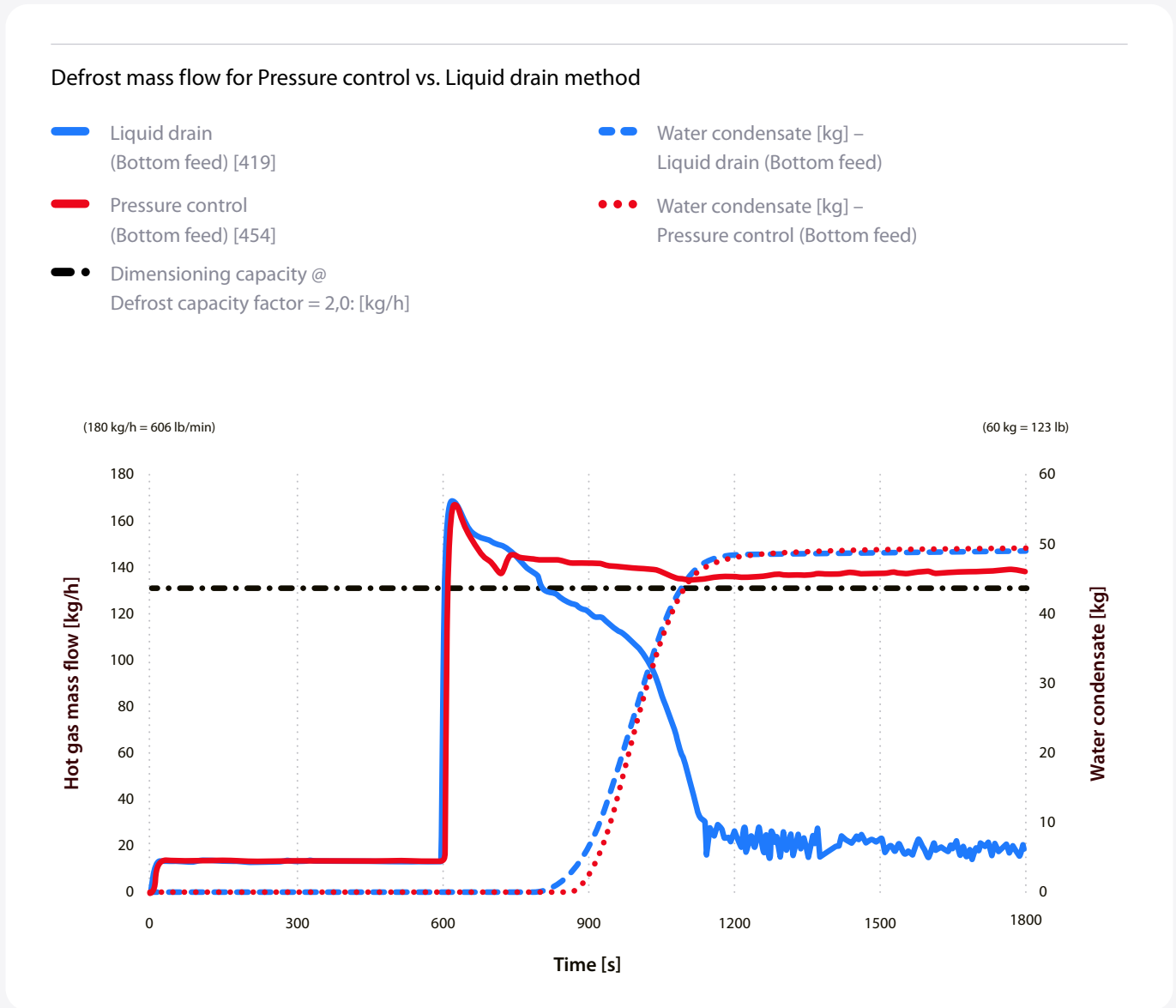

↑ Figure 6: Defrost mass flow for Pressure control vs. Liquid drain method measured in laboratory

# 04 Simulation model

Parallel with the laboratory and field tests described above, a simulation model has been developed and validated against the measurements.

The simulation model has been used to investigate the influence of varying the operating conditions, as well as quantifying some of the parameters, which can be difficult to measure (i.e. for example the mass of refrigerant in the evaporator during defrost, and the size of the convection losses from the evaporator to the surroundings (i.e. how much the defrost process heats up the cold room)).

The findings and experiences gained have been collected in a series of design recommendations for hot gas defrost systems including practical challenges such as piping arrangements, and recommendations for sizing valves and line components. The design recommendations have then been used to develop a new hot gas application in Danfoss Coolselector®2.

## 4.1 Simulation results

In figure 7 the defrost energy has been analyzed for Pressure control vs. Liquid drain method. The simulation supported by laboratory test shows that all ice has been removed after 17 minutes. At this stage, the non-condensed hot gas passing through the evaporator (blow-by gas) represents 24% of the injected hot gas for Pressure control system, whereas for the Liquid drain method it only represents 3%. If the defrost process is not terminated after 17 minutes, the losses will increase further. For the Pressure control system, the non-condensed hot gas amount will increase from 24% to 38%, whereas for the Liquid drain methods it will increase from 3% to 5%.



### Conclusion

- Losses (gas blow-by) using the Pressure control method is significantly higher than for the Liquid drain method.
- In a hot gas defrost system controlled with Liquid drain method, the defrost cycle termination only has a minor impact on the energy efficiency.

### Simulated hot gas mass flow Pressure control vs. Liquid drain method

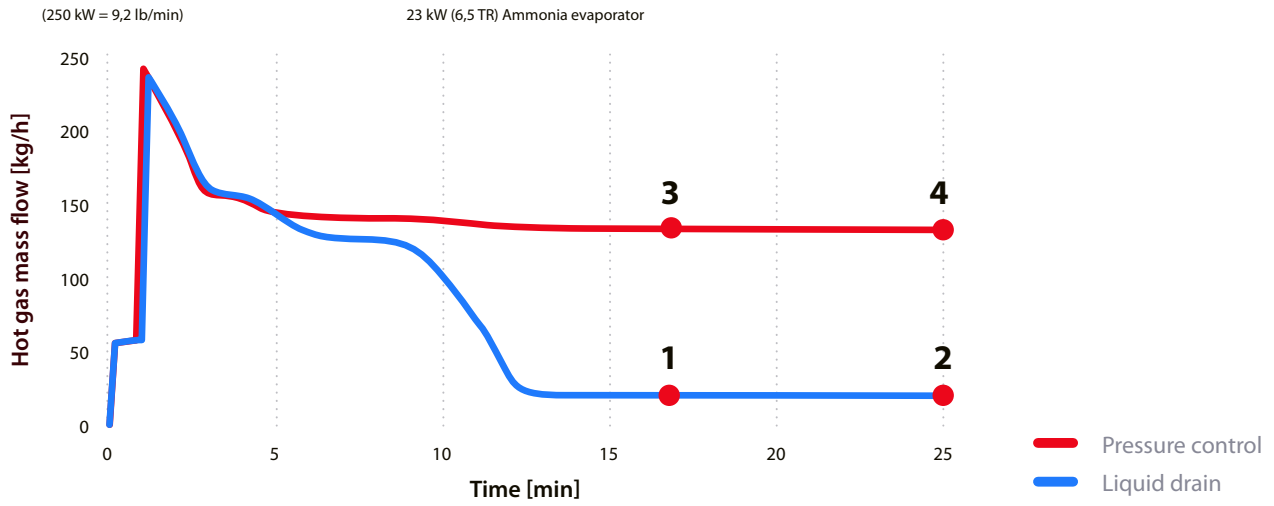

Time: 17 min

Time: 25 min

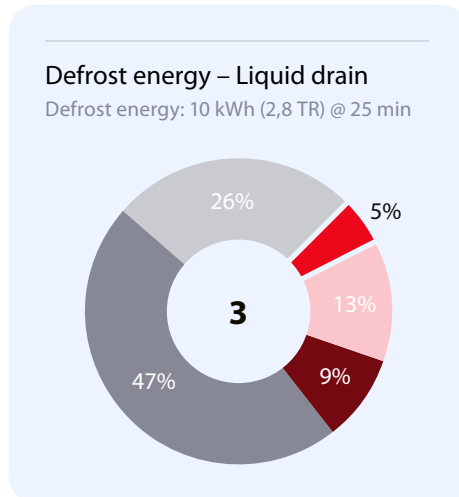
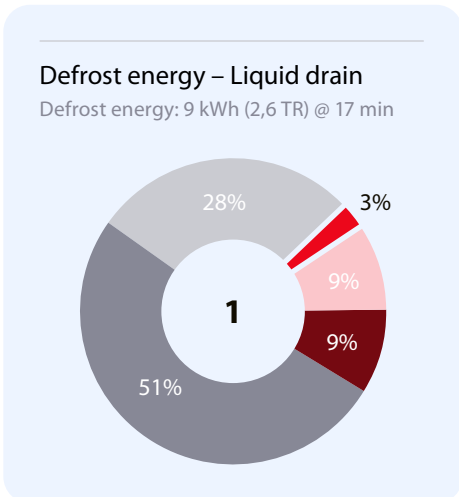
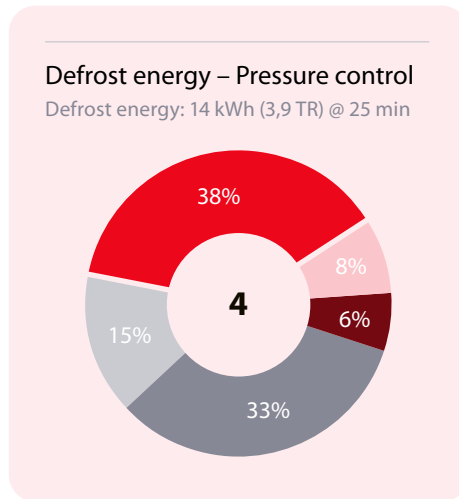
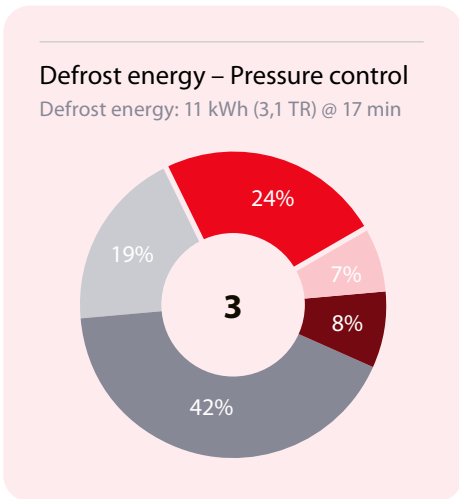

- Blow-by (re-comp.)
- Convection loss
- Ice heating
- Ice melting
- Coil heating

↑ Figure 7: Defrost energy – Pressure control vs. Liquid drain method

### Compressor work during defrost Pressure control vs. Liquid drain method

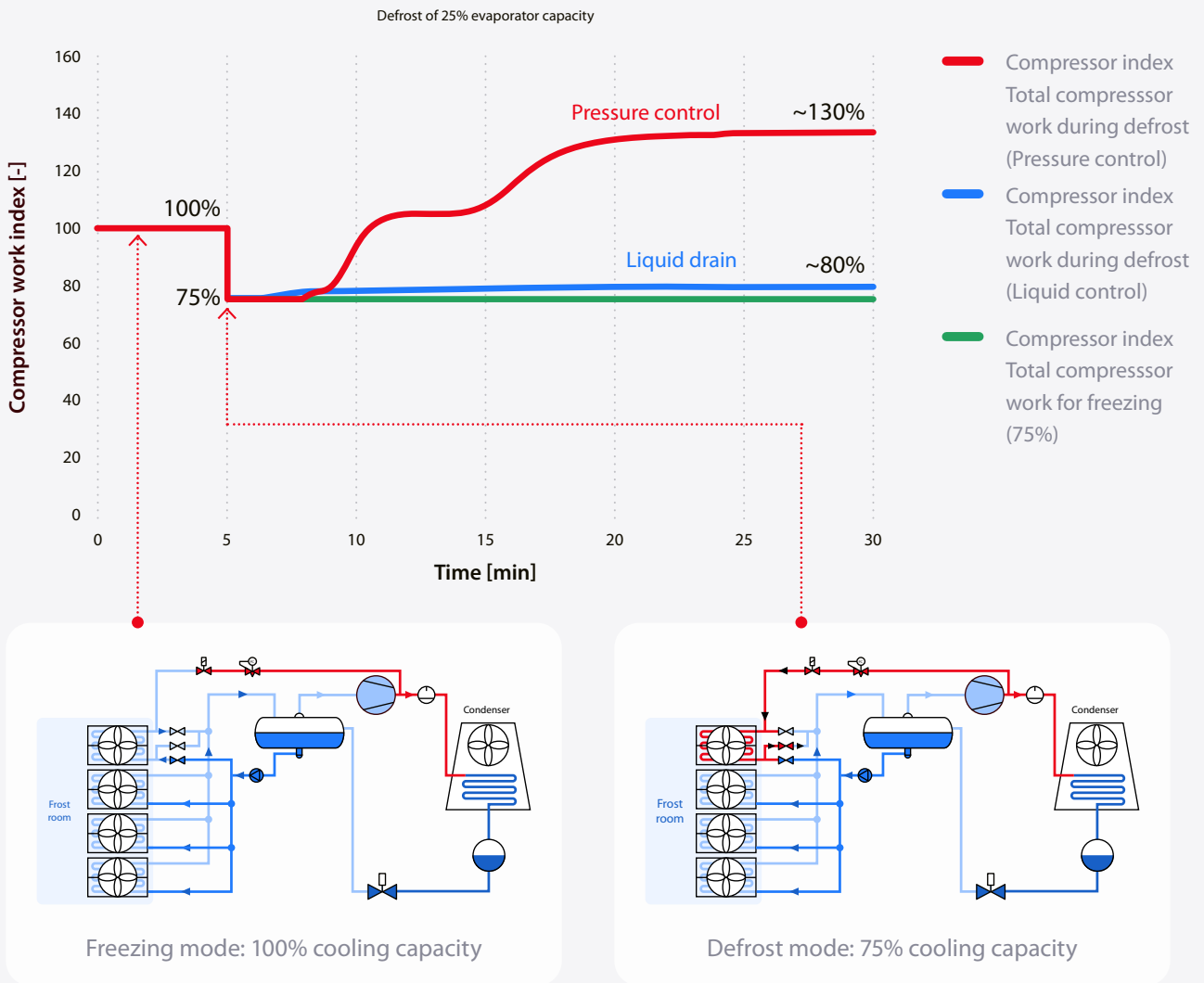

↑ Figure 8: Compressor work during defrost – Pressure control vs. Liquid drain method

In Figure 8 the compressor work during defrost has been analyzed for Pressure control vs. Liquid drain method. The example has four (4) evaporators (100%). When one of the evaporators is being defrosted, the cooling load and the required compressor work is reduced to 75%. By analyzing the two defrosting methods, the compressor work required is significantly different: The Liquid drain method requires ~80% compressor work at the end of the defrost process, whereas the Pressure control method requires 130%, which is more than during the normal cooling mode operation of the system.

## Conclusion

- Losses (gas blow-by) using the Pressure control method is significantly higher than for the Liquid drain method, and the Pressure control method has an impact on the requirements for compressor capacity in the refrigeration system.

# 05

## Danfoss ICFD Defrost Module based on the Liquid drain method

The newly developed ICFD Defrost Module (type ICFD 20) is based on the Liquid drain method and packaged into the widely acknowledged Danfoss ICF Valve Station. By combining the Liquid drain method with the ICF technology, Danfoss is bringing two great approaches into a highly efficient and compact solution. The solution makes it possible to equip an evaporator with ICF Valve Stations across the wet suction, liquid, hot gas, and defrost drain lines and provides an impressive range of benefits in respect of improved operational efficiency, easy installation, and energy savings.

The design is based on a mechanical float, and the operational mechanism is developed to operate at a very high pressure differential. It only allows liquid to pass through – no blow-by gas can bypass. The ICFD Defrost module has a very high capacity compared to its size due to its unique pressure balanced design. It has a wide application range, spanning evaporators up to 200kW (58 TR) evaporator capacity, and is fully compatible with the ICF 15-4, ICF 20-4, and ICF 20-6 range. It also provides an automatic capacity adjustment during operation with proportional opening for the necessary amount of liquid, which means that no settings are required. Finally, the design makes it possible to manage a liquid lift without any additional bypass valves thanks to a built-in bleed function. For more information on the ICFD Defrost solution please contact Danfoss or visit [www.icfdefrost.danfoss.com](http://www.icfdefrost.danfoss.com).

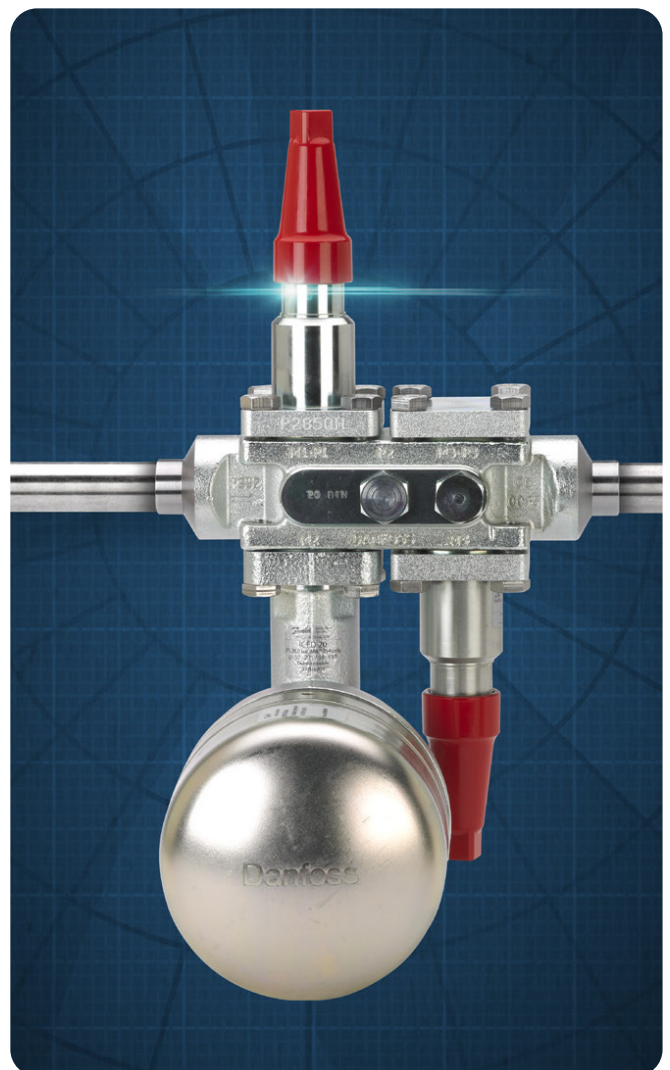

## 06

## Design requirements

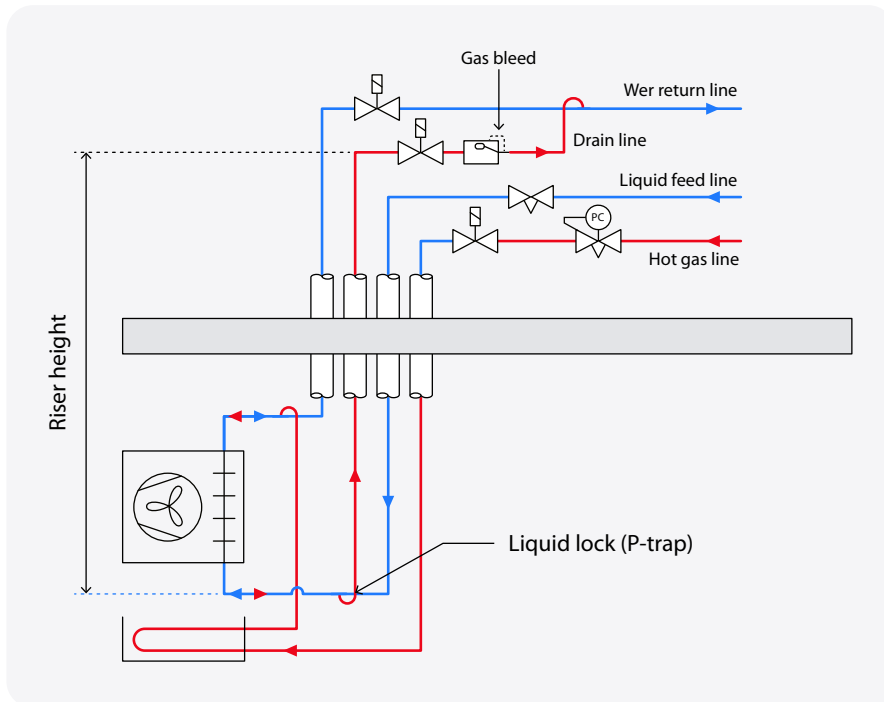

← Figure 9: Roof mounted valve station with Liquid drain method

In figure 9 a roof mounted valve station using the Liquid drain method is shown. The Liquid drain method is effective, but it requires that the system is designed properly. The riser shown in the evaporator valve station is a “liquid riser”. The challenges with this type of riser is to separate liquid and vapor at the inlet of the riser to have an effective defrost system.

When the defrost is started, the riser may be partly or fully filled with gas. As the liquid in the evaporator outlet is at saturated condition, a part of the liquid will evaporate due to the pressure difference required to lift the liquid through the riser.

The Liquid drain valve must be equipped with a bleed orifice sized to remove the above-mentioned gas initially standing in the riser and/or any flash gas produced during the defrost process. A gas by-pass orifice with a flow coefficient of approximately 5-7% of the Kv-value of the expansion device (float valve), is normally sufficient. The gas by-pass is a loss, but the mass flow for the gas is typically around 1/10 of the liquid mass flow, which means that the loss is minor, around  $\approx 0,5\%$ .

**Note:**

The Danfoss ICFD Defrost solution based on the Liquid drain method has a built-in gas by-pass orifice that matches the capacity of the drain valve, and the recommended riser heights.

### ICF-Liquid drain

Capacity reduction due to riser

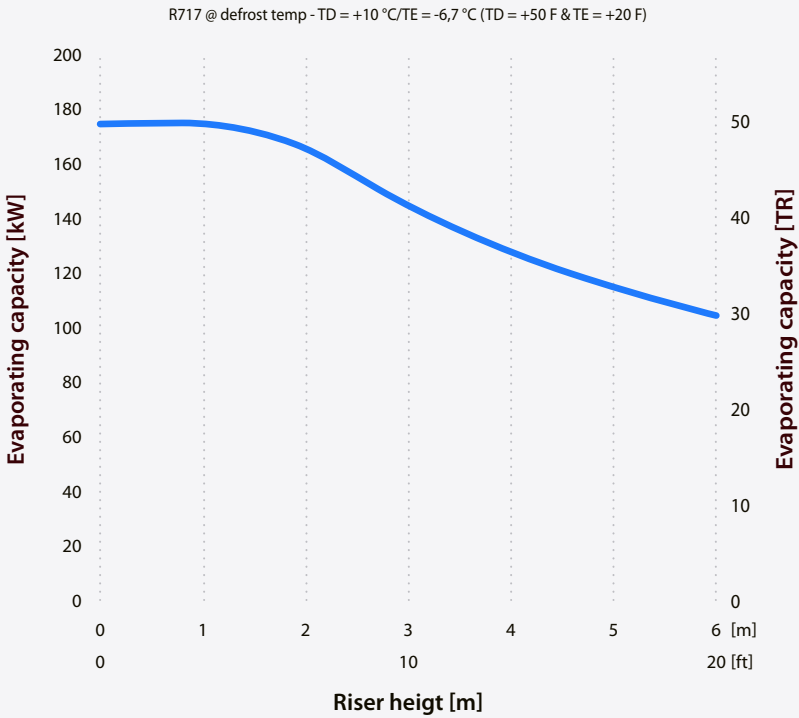

### Important

When sizing hot gas systems, it is important to take the actual riser height into account, because the pressure difference caused by the liquid height of the riser will reduce the capacity (see Figure 10). For the Danfoss ICFD Defrost solution the maximum recommended riser height is 5 m (16 ft). A liquid-lock (P-trap) is an effective way to ensure the gas is not unintendedly transferred to liquid riser and reducing the capacity of the drain valve.

← Figure 10: Capacity reduction due to riser height

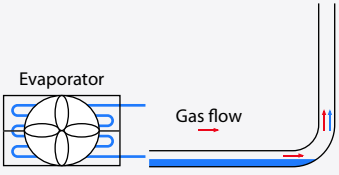
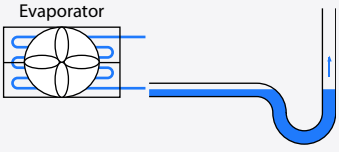
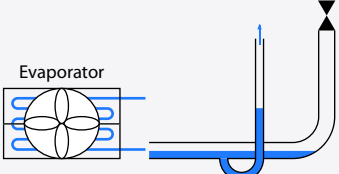

| Riser design  | Feature  |
|---|--|
|  | <p>☹️</p> <p><b>Codensate drain line with riser <b>without P-trap</b></b></p> <ul style="list-style-type: none"> <li>• No P-trap increase risk of gas "blow-by" (increased gas re-compression and increased defrost duration)</li> </ul>               |
|  | <p>☺️</p> <p><b>Common Liquid feed / condensate drain line with riser <b>with P-trap</b></b></p> <ul style="list-style-type: none"> <li>• P-trap minimize gas "blow-by" (loss) in liquid drainer</li> </ul>  |
|  | <p>☺️</p> <p><b>Separate riser with P-trap in condensate drain line</b></p> <ul style="list-style-type: none"> <li>• Separate riser enable optimizing riser pipe diameter</li> <li>• P-trap minimize gas "blow-by" (loss) in liquid drainer</li> </ul> |

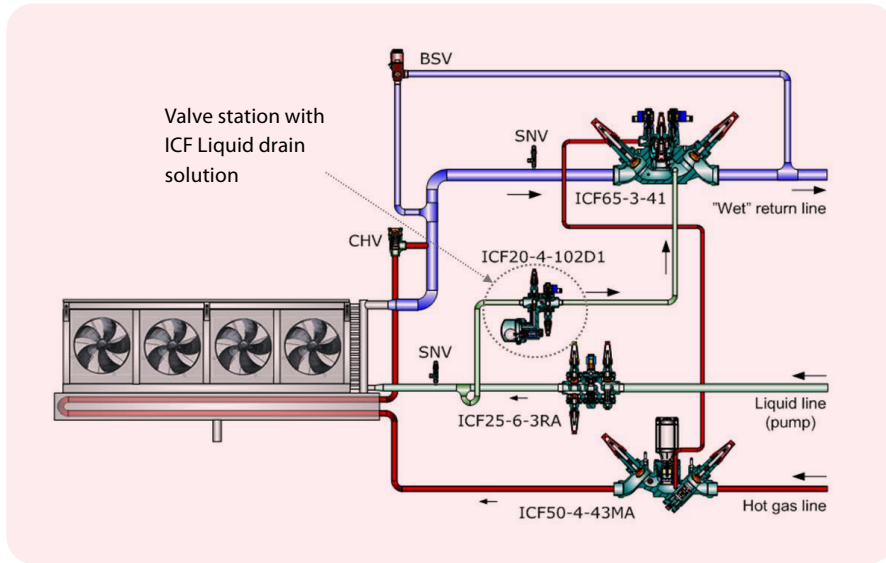

↑ Figure 11: Liquid riser in systems with Liquid drain systems

← Figure 12: Example of a complete evaporator valve station including the Danfoss ICFD Defrost solution based on the Liquid drain method

Figure 11 shows an evaporator with different riser connections. Riser with liquid-lock (P-trap) is an effective way to ensure the gas is not unintentionally transferred to liquid riser.

Figure 12 shows a complete evaporator valve station equipped with Danfoss ICF valve stations in Liquid- Wet return- Hot gas and Liquid drain line. With this compact solution, the complete evaporator solution becomes very easy and fast to install, and reduce space requirements. It may also provide a cost attractive solution compared to using individual valve components.

# 07 Field test

Several field tests have been conducted with the newly developed Danfoss ICFD Defrost Module. In all tests, the results clearly show the benefits of the Liquid drain method. In the example below, two evaporators in a cold store facility were equipped with extensive measurement equipment, being able to document the benefits in detail.

Figure 13 displays the test results from one evaporator tested over two (2) weeks – one week with the Pressure control method and one week with the Liquid drain method.

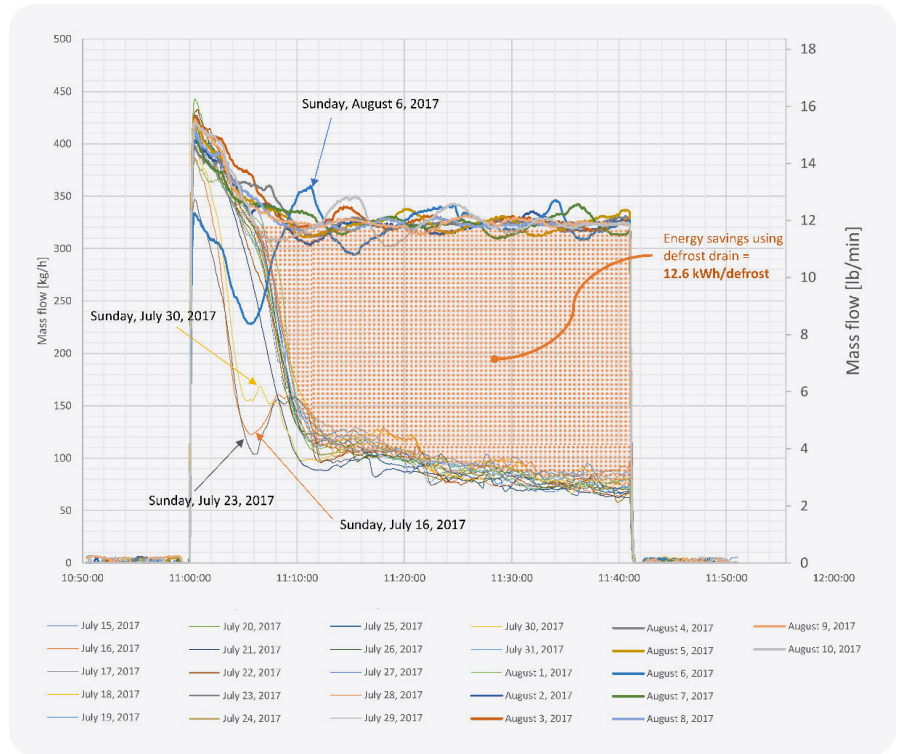

### Conditions & results:

- Evaporator: 41 kW @ -25 °C (12 TR @ -13 °F)
- Defrost: 40 minutes, once a day
- Savings: 12.6 kWh per defrost
- Saving potential, 1 evaporator/year: 635 EUR (≈754 USD)
  - Calculation: (12.6 kWh x 0.14 EUR/kWh) x 360 days = 635 EUR



### Note:

Electricity rate based on EuroStat Statistics, Energy Database: Electricity prices for industrial consumers: EU 28 countries 2016 (taxes and levies included): 0.14 EUR / kWh.

Source: <http://appsso.eurostat.ec.europa.eu/nui/submitViewTableAction.do>

↑ Figure 13: Field test results from a European customer test site: Hot gas mass flow from old Pressure control system vs. the new Danfoss ICFD Defrost Module based on the Liquid drain method.



### Conclusion

The conducted field tests document that the saving potential obtained in the laboratory test, and further quantified using the simulation tool, can also be obtained on a “real” operating system.

# 08

## Dimensioning mass flow in hot gas defrost lines

Energy efficient hot gas defrost systems is not just a question about an effective defrost control. The tests conducted also document that the complete defrost system should be designed appropriately to ensure high efficiency and fast defrost. In this section, the most important design criteria are described so that the correct valves and pipe sizes can be selected.

### 8.1

#### Dimensioning capacity

Determining the hot gas capacity in the defrost lines is a question of defining the necessary hot gas mass flow in the selected line. Typically, some rules of thumb are used, which relate to the dimensioning cooling capacity of the evaporator(s) the selected hot gas line connects to:

$$\dot{m}_{hot\ gas} = Defrost\ capacity\ factor \cdot \frac{Dimensioning\ cooling\ capacity}{Defrost\ enthalpy\ difference}$$

(Eq. 1)

The dimensioning cooling capacity is the cooling capacity of the evaporator(s) being defrosted. This value indirectly tells the size of the evaporator.

The defrost enthalpy difference equals the energy content of the hot gas – it is equal to the enthalpy difference between point C and D\* in Figure 14.

The defrost capacity factor is a value selected based on experience, and it is important for sizing hot gas lines, hot gas solenoids, drain valves and drain lines in a proper defrost system, but it is **not** intended for calculating exact defrost mass flow in the system. A defrost capacity factor of 2 is common practice and shows good correlation with the tests. Normally, the value is selected between 1 and 3 – depending on the actual operating conditions.

## 8.2 Dimensioning quality

The dimensioning quality  $X$  is used to determine the position of point D at the inlet to the defrost drain line. The term “quality” is a measure of the mass flow of gas compared to the total mass flow of refrigerant. The dimensioning quality will be quite different based on the drain control method selected.

### 8.2.1 Liquid drain method

For the Liquid drain method, the dimensioning quality should always be 0.0 – i.e. the refrigerant in point D is saturated liquid (Figure 14). The function – or the purpose – of a float valve in the defrost drain line is exactly to avoid (as far as possible) gas to pass through the float valve, but only let liquid pass through.

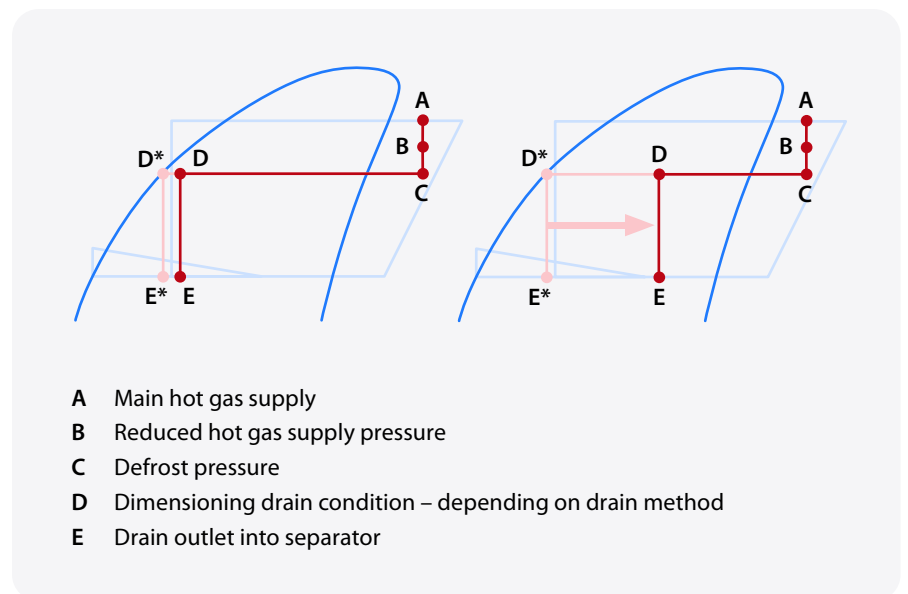

Figure 14: → Defrost principle in log(p)-h diagram

### 8.2.2 Pressure control method

For the Pressure control method, the defrost process will be quite different. Initially, all hot gas supplied to the evaporator will condense, and the valve will see liquid at the outlet of the evaporator. Later in the process, some gas will not condense in the evaporator, and the valve will see a mixture of liquid and gas. This process is illustrated in Figure 14 (from D\* to D). Selecting the right dimensioning quality for pressure controlled drain is very important for selecting the right valve size. If a dimensioning quality of 0.0 is selected (saturated liquid), then the resulting valve will be relatively small, which could mean that defrost will be prolonged at the end of the defrost cycle as gas cannot be passed through the valve efficiently. If a dimensioning quality of 1.0 is selected (saturated gas), then the resulting valve will be relatively large, meaning that a lot of gas will be bypassed (equals larger energy consumption) and the valve can become unstable when pure liquid enters the valve in the beginning of the defrost cycle. Using a relatively low dimensioning quality equal to 0,05 ensures that the valve is stable when liquid enters it, and that the amount of bypassed gas is minimized.

### 8.3 Default dimensioning values

The values of the defrost capacity factor and the dimensioning quality are selected based on experience, and it is important for designing a proper defrost system, as are defrost temperature and the design pressure drop in the hot gas line.

Commonly used values:

- Defrost capacity factor = 2
- Dimensioning quality:
  - = 0.00 for Liquid drain method
  - = 0.05 for Pressure control method
- Defrost design temperature = +10 °C (50 °F)
- Hot gas velocity ≈ 25 m/s (82 ft./s)
- Pressure drop ≈ 1 bar [≈ 5 K for ammonia] (14,5 psi [≈ 9 °F]) in the complete hot gas line, would normally lead to an acceptable choice of pipe size and valve capacity

### 8.4 Sizing defrost system – hot gas lines

The defrost design mass flow for one evaporator can be calculated using Equation (1). The total mass flow in the main hot gas defrost line is calculated as the sum of the required mass flow for all evaporators defrosted at the same time in the system.

Figure 15: Hot gas defrost principle in an industrial overfeed system →

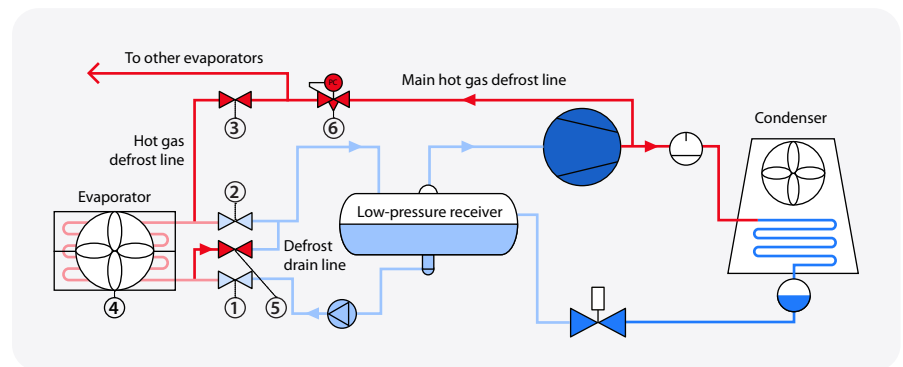

It is often assumed that the pressure drop in the hot gas defrost line is less important, but it is strongly recommended to calculate it as precisely as possible, especially for systems with floating condensing pressure, where low condensing pressure may appear (which again means low driving pressure differential across the defrost valve (3)).

When the total pressure drop in the hot gas line is calculated, the minimum supply pressure can be calculated with the pre-conditions given in chapter 8.3. If the maximum supply pressure (condensing pressure) is significantly higher than needed, it is good practice to consider an outlet pressure regulator in the main hot gas supply line (regulated hot gas) to reduce the pressure. Too high supply pressure may lead to an increased pressure in the evaporator, and significantly increased gas “blow-by” in Pressure controlled defrost systems. For large evaporators, regulated hot gas is always recommended for safety reasons.

# 09

## Safety considerations

Hot gas defrost is a very common and effective method. However, experience shows that defrost systems must to be designed and operated according to sound practice to ensure safe operation.

### 9.1

#### Design safety considerations

Historically, hot gas defrost systems have been designed in different ways, and it is important to notice that some of these systems can create a safety risk if the conditions are changed slightly. The purpose of this section is to highlight good design practice, and stress design features that need to be considered carefully to avoid safety risks. Further information can for example be found in IAR's guidelines.

##### 9.1.1 Hot gas injection

All examples in this document are shown with hot gas injection into evaporators in the top of the evaporator. This method is generally seen as a safe solution with a **very low risk** for "liquid hammer". Other hot gas injection methods can be used safely, but as a rule they will require more detailed description to document and ensure safe operation.



### 9.1.2 Regulated hot gas pressure

The hot gas supply needs to be able to build up the pressure in the evaporator to approximately +10 °C (50 °F). The required hot gas supply pressure depends on the pressure drop in the supply system. Defrosting systems designed with the Liquid drain method need to be equipped with a back-pressure control valve if the hot gas supply pressure is higher than accepted for the evaporator. For safety reasons, it is good design practice always to design the hot gas system with a back-pressure control valve to ensure that the pressure is not too high.

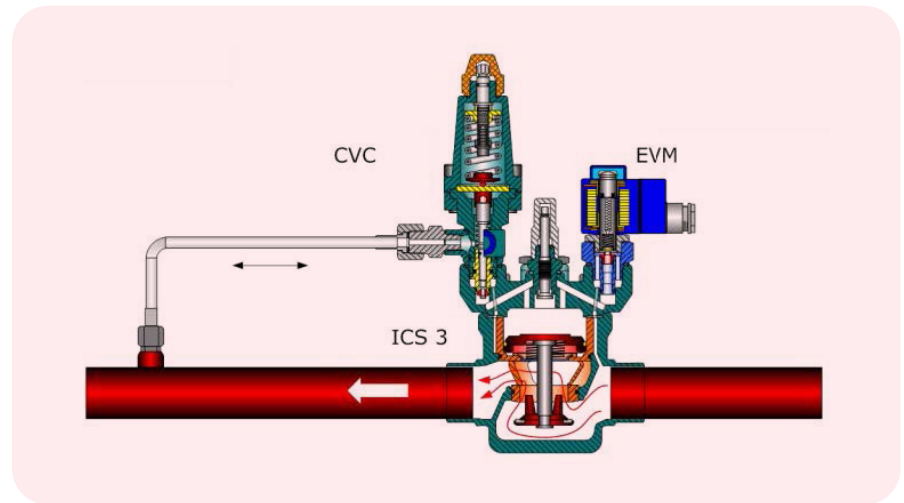

Figure 16: Example of "Regulated hot gas pressure" (back pressure regulator) →

### 9.1.3 Soft opening solenoids for hot gas injection

Opening a large hot gas solenoid valve with a large differential pressure can create a big pressure impact on the refrigeration system. It is good design practice to install a "soft opening solenoid" in the hot gas line when large valves are installed. Common practice shows, that the pressure impact is generally acceptable for direct opening valves ≤ DN25 (1 in).

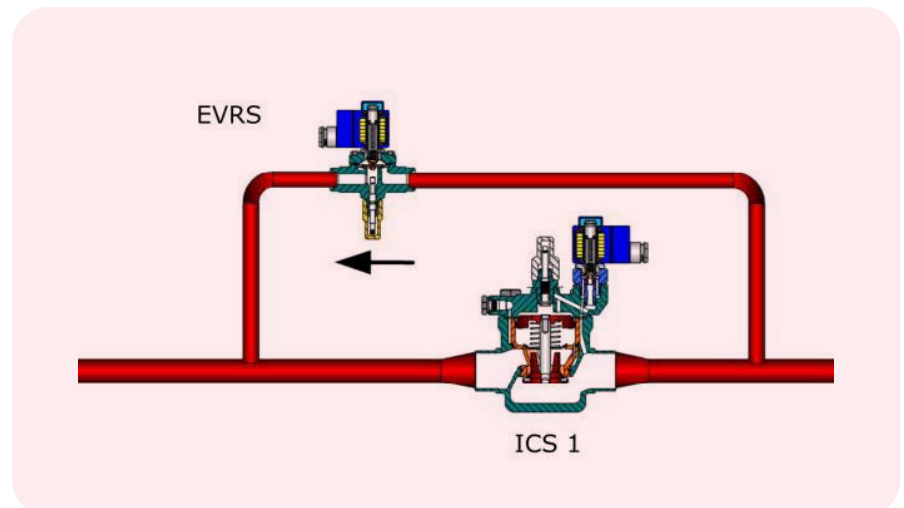
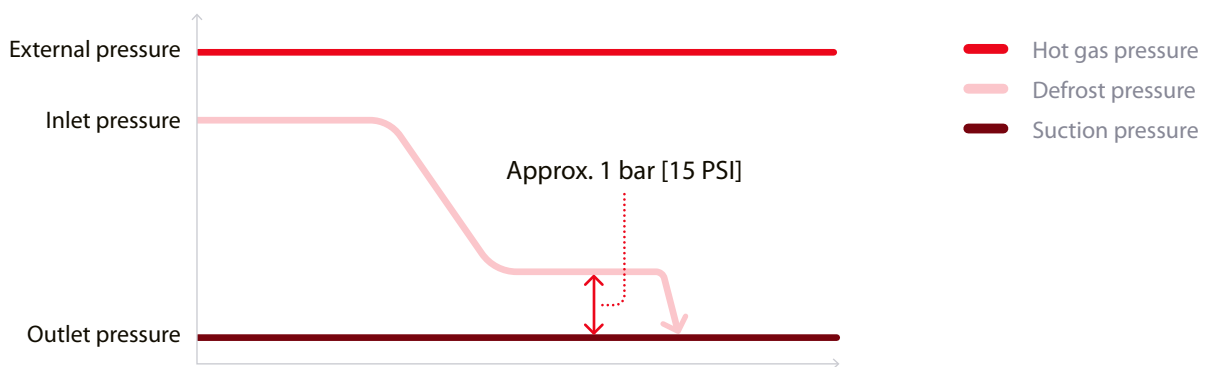
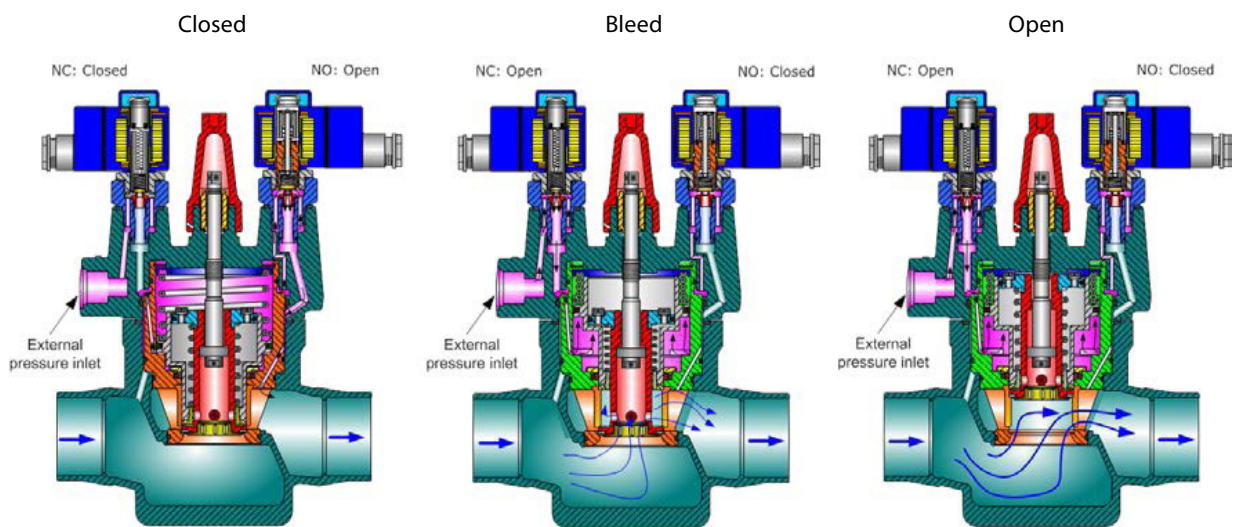

Figure 17: Example of "Soft opening solenoid solution" →

### 9.1.4 Soft opening solenoids for pressure equalizing at end of defrosting

When the defrost process is completed, the evaporator pressure is equal to defrost pressure. The pressure in the evaporator is 6 to 7 bar (87 to 102 psi), and the pressure in the wet return line is 0,5 to 1 bar (7 to 14 psi) which create a differential pressure of  $\approx 5,5$  bar (80 psi). To avoid pressure shocks in the system, when a system is returned into freezing mode, it is recommended to install a "soft opening" solenoid valve (2-step valve) in the wet return line.



↑ Figure 18: Example of 2-step solenoid valve ("Soft opening solenoid valve")

### 9.1.5 Draining condensate from hot gas lines

When a hot gas line is not in operation, any remaining gases easily condense. It is good practise to install the hot gas lines with a slope, and install drain facilities at the lowest point.

↓ Figure 19: Example of draining condensate from hot gas lines

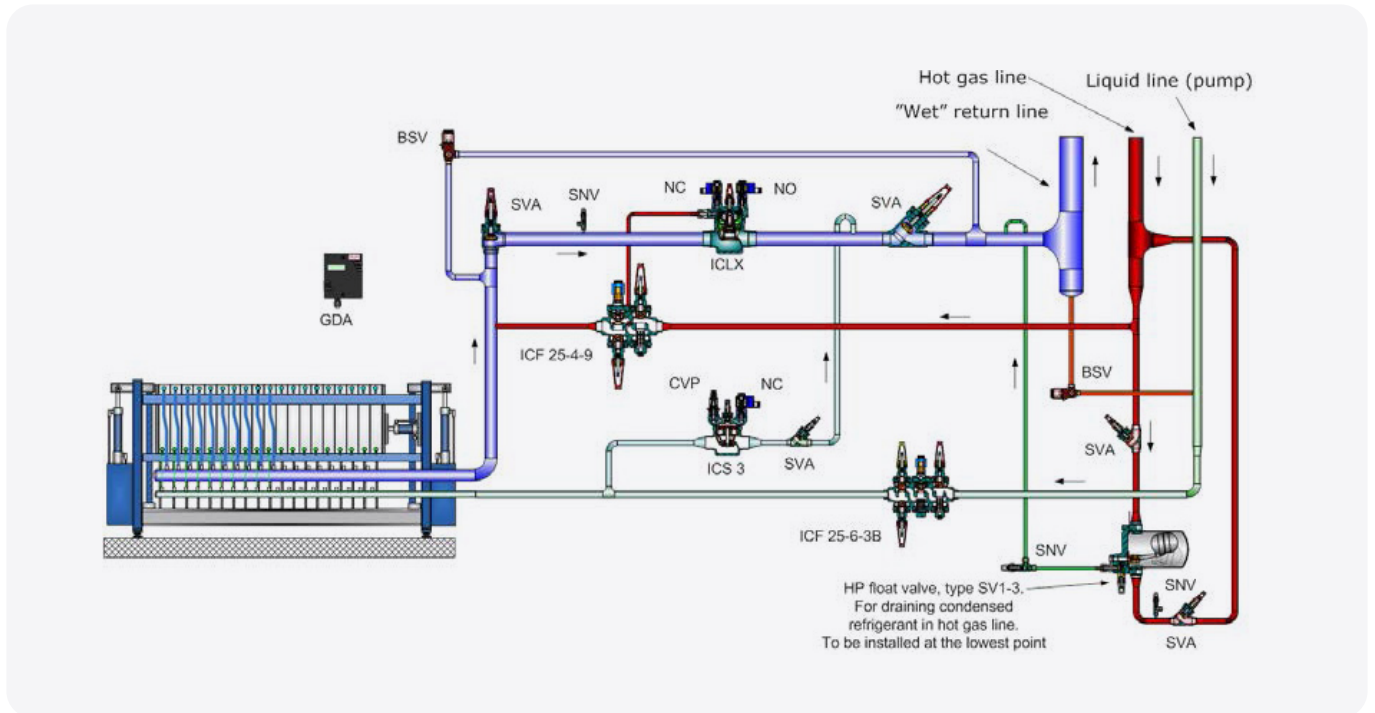

# 10

## Bibliography

- [1] Aljuwayhel, N.F., 2006. Numerical and Experimental Study of the Influence of Frost Formation and Defrosting on the Performance of Industrial Evaporator Coils.
- [2] CPI, 2008. Cold Front, 2008 Vol. 8 No. 3 Defrost (<https://www.irc.wisc.edu/?/newsletter>).
- [3] CPI, 2009. Cold Front 2009 Vol. 9 No. 1. Understanding Hydraulic shocks (<https://www.irc.wisc.edu/?/newsletter>).
- [4] CSB-Safety-Bulletin, 2015. Key Lessons for Preventing Hydraulic Shock in Industrial Refrigeration Systems Anhydrous Ammonia Release at Millard Refrigerated Services, Inc.U.S. Chemical Safety and Hazard Investigation Board.
- [5] Hoffenbecker, N., 2008. Investigation of Alternative Defrost Strategies; Master Thesis University of Wisconsin – Madison.
- [6] IIR, 1992. Bulletin No. 116: Avoiding Component Failure in Industrial Refrigeration Systems Caused by Abnormal Pressure or Shock.
- [7] Martin, S.C., 2009. Condensation-induced water hammer in a horizontal pipe, 3rd IAHR International Meeting Brno, Czech Republic.
- [8] Person , A., 2008. Hot Gas Defrost on Recirculated Air Units, IIR Technical paper 2008.
- [9] Stoecker, W.F., Lux , J.J. & Kooy, R.J., 1983. Energy considerations in hot-gas defrosting of industrial refrigeration coils.
- [10] Welch, J., 2012. Hot Gas Defrost on Recirculated Air Units, IIR Technical paper 2012.
- [11] Skovrup M. J. et. al. 2017, Energy savings comparing pressure controlled and liquid drain controlled hot gas defrost. IIR – 7th Conference on Ammonia and CO2 Refrigeration Technologies, Ohrid, Macedonia, May 2017.
- [12] Vestergaard N. P. et. al. 2016, Analysis of various ammonia defrosting systems 12th IIR Gustav Lorentzen Natural Refrigerants Conference, Edinburg, Scotland 21-24, August 2016.
- [13] Vestergaard N. P. et. al. 2017, Design requirements for effective ammonia defrost systems. IIR – 7th Conference on Ammonia and CO2 Refrigeration Technologies, Ohrid, Macedonia, May 2017.

# 11

## ANNEX: Additional safety considerations

### 11.1

#### Operation safety considerations

Experience over the past decades shows that it is important to implement a proper defrost procedure to eliminate critical situations. Defrosting can be conducted safely, manually operating the valve in the right sequence, however historically experience shows that it requires experienced operators and good procedures. Unfortunately, the history also shows that if procedures are not followed, serious accidents can happen. It is strongly recommended always to use automated systems with well-defined and safe defrosting sequences, to eliminate human mistakes.

### 11.2

#### Minimize risk of liquid hammer

Liquid hammer is the phenomena that is often mentioned in connection with abnormal defrost procedures. Liquid hammer is the “nick name” of various phenomena that result in high pressure impact in the system. Typically, two phenomena are important when designing and operating hot gas defrost systems:

01

Pressure impact caused by Vapour-propelled liquid slug

02

Pressure impact caused by Condensation-induced shock

### 11.3

## Pressure impact caused by Vapour-propelled liquid slug

Vapour-propelled liquid slug should be considered in hot gas lines and wet return lines.



### Hot gas lines

If a hot gas system is designed with “pockets” that can collect condensed liquid, there is a risk of vapour-propelled liquid slug, when hot gas valves are opened. The mitigation action is to eliminate liquid “pockets”, e.g. as described in chapter 9.1.5. A soft opening hot gas valve (9.1.3) may also reduce the impact.



### Wet return lines

When the defrost process is completed, the evaporator pressure is equal to defrosting pressure. Before the evaporator can be put into normal operation, the pressure must be equalized to the evaporating pressure. If the equalizing is done too fast, the gas-liquid slug can be accelerated and create high impact on the system. The correcting action is to eliminate pressure impact by slowly equalizing the pressure.

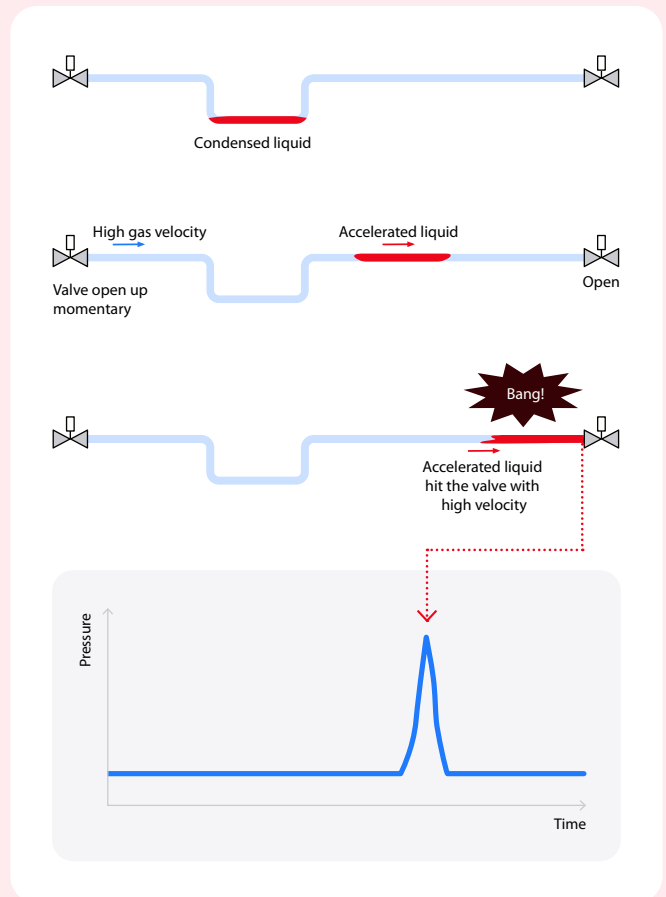

↑ Figure 20: Example on pressure impact caused by Vapour-propelled liquid slug

## 11.4 Pressure impact caused by Condensation-induced shock

Pressure impact caused by Condensation-induced shock is a phenomenon that has been reported to have caused serious accidents in ammonia refrigeration systems.

From a general point of view, the risk of creating “liquid hammer” occurs when hot gas is injected into cold liquids.

Tests conclude that the risk for Condensation-induced shock increases:

- When the velocity of injected hot gas is high
- When the degree of sub cooling of liquid is large
- When the liquid temperature is low
- When the liquid level (amount of liquid) in the pipes / evaporator coil /headers is high
- When the pipe diameter is large

On a typical evaporator design this means:

- Remove liquid from evaporator before defrost if possible.
- Use soft opening solenoids for large size hot gas lines.
- Reduce hot gas supply pressure if it is significantly higher than required

Large pipe diameters are more critical than small diameters (e.g. headers or “dead pipe ends”).

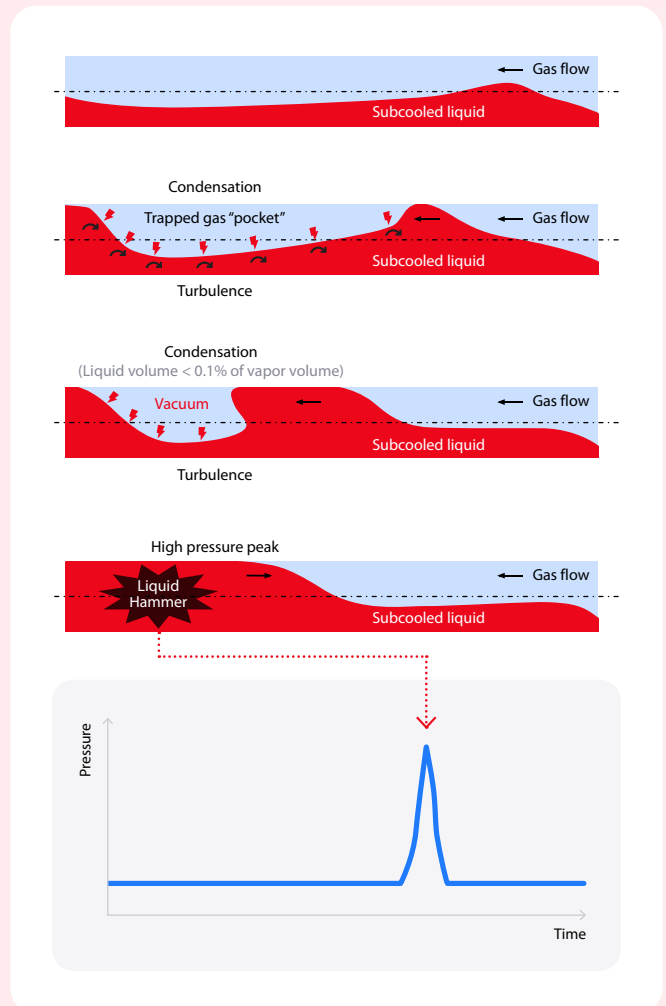

↑ Figure 21: Example on pressure impact caused by Condensation-induced shock

Explore our solutions  
danfoss.com

The Danfoss logo is a red rounded rectangle containing the word "Danfoss" in a white, elegant, cursive script font.

**Danfoss A/S**  
Nordborgvej 81  
6430 Nordborg  
Denmark  
danfoss@danfoss.com  
CVR reg. no. 20165715

© Danfoss 2026

---

Any information, including, but not limited to information on selection of product, its application or use, product design, weight, dimensions, capacity or any other technical data in product manuals, catalogues descriptions, advertisements, etc. and whether made available in writing, orally, electronically, online or via download, shall be considered informative, and is only binding if and to the extent, explicit reference is made in a quotation or order confirmation. Danfoss cannot accept any responsibility for possible errors in catalogues, brochures, videos and other material. Danfoss reserves the right to alter its products without notice. This also applies to products ordered but not delivered provided that such alterations can be made without changes to form, fit or function of the product. All trademarks in this material are property of Danfoss A/S or Danfoss group companies. Danfoss and the Danfoss logo are trademarks of Danfoss A/S. All rights reserved.

---