



iC7-Marine PROFINET

PROFINET RT



Contents

1 Introduction and Safety

1.1 Purpose of the Operating Guide	5
1.2 Additional Resources	5
1.3 Safety Symbols	5
1.4 Qualified Personnel	6
1.5 Safety Precautions	6
1.6 Abbreviations	7
1.7 Trademarks	8
1.8 Version History	8

2 Product Overview

2.1 PROFINET Features and Technical Data	10
2.2 Communication Profiles and Objects	10
2.2.1 Overview	10
2.2.2 iC Speed Profile	11
2.2.3 iC Generic	13
2.2.4 PROFIdrive - Standard Telegram 1	15
2.2.5 iC Active Front End	18
2.3 Submodules	20
2.4 Functional Extension Options	21
2.5 Network Topologies	22

3 Fieldbus Cable Connections

3.1 Prerequisites for Installation	25
3.2 Installation in Frequency Converters	25
3.3 Installation in System Modules	26
3.4 EMC-compliant Installation	27

4 Configuration

4.1 Selecting the Fieldbus Profile	29
4.2 Configuring Fieldbus Protection Settings for the Propulsion & Machinery Application	29
4.3 Configuring Fieldbus Protection Settings for the Active Front End Application	30
4.4 Configuring the Ethernet Interface	32

4.5 Configuring Name of Station	33
4.6 GSDML File (Device Description File)	33
4.7 Reference and Main Actual Handling	33
5 Parameter Access	
5.1 Overview	35
5.2 PROFIdrive Parameter Numbers	35
6 Troubleshooting	
6.1 Diagnostics	36
6.2 PROFINET Report	36
6.3 Configuring Port Mirroring Settings	37
6.4 Identifying a Unit	37
6.5 Fieldbus Indicator LEDs	37

1 Introduction and Safety

1.1 Purpose of the Operating Guide

This operating guide provides information about configuring the system, controlling the drive or power converter, accessing parameters, programming, troubleshooting, and some typical application examples.

The operating guide is intended for use by qualified personnel, who are familiar with the iC7 drives and power converters, PROFINET technology, and the PC or PLC that is used as a master in the system.

Read the instructions before configuring PROFINET, and follow the procedures in this guide.

1.2 Additional Resources

Additional resources are available to help understand the features, and safely install and operate the iC7 series products:

- Safety guides, which provide important safety information related to installing iC7 series drives and power converters.
- Installation guides, which cover the mechanical and electrical installation of drives, power converters, or functional extension options.
- Design guides, which provide technical information to understand the capabilities of the iC7 series drives or power converters for integration into motor control and monitoring systems.
- Operating guides, which include instructions for control options, and other components for the drive.
- Application guides, which provide instructions on setting up the drive or power converter for a specific end use. Application guides for application software packages also provide an overview of the parameters and value ranges for operating the drives or power converters, configuration examples with recommended parameter settings, and troubleshooting steps.
- *Facts Worth Knowing about AC Drives*, available for download on www.danfoss.com.
- Other supplemental publications, drawings, and guides are available at www.danfoss.com.

Latest versions of Danfoss product guides are available for download at <https://www.danfoss.com/en/service-and-support/documentation/>.

1.3 Safety Symbols

The following symbols are used in Danfoss documentation and products.



DANGER

Indicates a hazardous situation which, if not avoided, will result in death or serious injury.



WARNING

Indicates a hazardous situation which, if not avoided, could result in death or serious injury.



CAUTION

Indicates a hazardous situation which, if not avoided, could result in minor or moderate injury.

NOTICE

Indicates information considered important, but not hazard-related (for example, messages relating to property damage).

	ISO warning symbol for general warnings
	ISO warning symbol for hot surfaces and burn hazard
	ISO warning symbol for high voltage and electric shock
	Symbol for indicating the required discharge time of the capacitors in the product.
	ISO action symbol for referring to the instructions

1.4 Qualified Personnel

Correct and reliable transport, storage, installation, operation, and maintenance are required for the trouble-free and safe operation of the product. Only qualified personnel are allowed to install and operate this equipment.

Qualified personnel are defined as trained staff, who are authorized to install, commission, and maintain equipment, systems, and circuits in accordance with pertinent laws and regulations. Also, the qualified personnel must be familiar with the instructions and safety measures described in this guide.

1.5 Safety Precautions

DANGER



HIGH VOLTAGE

Drives and power converters contain high voltage when connected to AC mains input, DC supply, or load sharing. Failure to perform installation, startup, and maintenance by qualified personnel can result in death or serious injury.

- Only qualified personnel are allowed to perform installation, startup, and maintenance.

WARNING

UNINTENDED START

When the drive or power converter is connected to the AC mains or connected on the DC terminals, the motor may start at any time, causing risk of death, serious injury, and equipment or property damage.

- Stop the drive or power converter before configuring parameters.
- Make sure that the drive or power converter cannot be started by an external switch, a fieldbus command, an input reference signal from the control panel, or after a cleared fault condition.
- Disconnect the drive or power converter from the mains whenever safety considerations make it necessary to avoid an unintended motor start.
- Check that the drive or power converter and any driven equipment are in operational readiness.

WARNING

DISCHARGE TIME

The drive or power converter contains DC-link capacitors, which can remain charged even when the drive or power converter is not powered. High voltage can be present even when the warning indicator lights are off. Failure to wait the specified time after power has been removed before performing service or repair work can result in death or serious injury.

- Stop the motor.
- Disconnect all power sources, including permanent magnet type motors.
- Wait for capacitors to discharge fully. The discharge time is specified on the drive or power converter product label.
- Measure the voltage level to verify full discharge.

WARNING
LEAKAGE CURRENT HAZARD

Leakage currents exceed 3.5 mA. Failure to ground the drive or power converter properly can result in death or serious injury.

- Ensure that the minimum size of the ground conductor complies with the local safety regulations for high touch current equipment.

WARNING
EQUIPMENT HAZARD

Contact with rotating shafts and electrical equipment can result in death or serious injury.

- Ensure that only trained and qualified personnel perform installation, start-up, and maintenance.
- Ensure that electrical work conforms to national and local electrical regulations.
- Follow the procedures in this guide.

CAUTION
INTERNAL FAILURE HAZARD

An internal failure in the drive or power converter can result in serious injury when the drive or power converter is not properly closed.

- Ensure that all safety covers are in place and securely fastened before applying power.

1.6 Abbreviations

Table 1: Abbreviations

Abbreviation	Definition
AR	Application relations
BMPA	Base mode parameter access
CAN	Controller area network
CiA	CAN in Automation
CTW	Control word
DAP	Device access point

Table 1: Abbreviations - (continued)

Abbreviation	Definition
DCP	Discovery and configuration protocol
DHCP	Dynamic host configuration protocol
DO	Drive object
DU	Drive unit
EMC	Electromagnetic compatibility
I/O	Input/Output
IP	Internet protocol
IRT	Isochronous real time
LED	Light-emitting diode
LLDP	Link layer discovery protocol
LSB	Least significant bit
MAP	Module access point
MAV	Main actual value
MRC	Media redundancy client
MRM	Media redundancy manager
MRP	Media redundancy protocol
MRV	Main reference value
MSB	Most significant bit
NAP	Network access point
PAP	Parameter access point
PC	Personal computer
PCD	Process channel data
PDEV	P-Device
PLC	Programmable logic controller
PNU	Parameter number
PPO	Process parameter object
REF	Reference
RFG	Ramp frequency generator
RT	Real time
STW	Status word

1.7 Trademarks

PROFIBUS® and PROFINET® are registered trademarks of PROFIBUS and PROFINET International (PI).

PROFIdrive® is a registered trademark licensed by PROFIBUS and PROFINET International (PI).

1.8 Version History

This guide is regularly reviewed and updated. All suggestions for improvement are welcome.

The original language of this guide is English.

Table 2: Version History

Version	Remarks
AQ481922043454, version 0201	GSDML version information and configuration instructions updated.
AQ481922043454, version 0101	First release.

2 Product Overview

2.1 PROFINET Features and Technical Data

Fieldbus options for iC7 series drives and power converters are integrated in the control board. Fieldbuses are enabled on communication interfaces X1 and X2 only. Modbus TCP is offered as standard, and other protocols such as PROFINET RT can be selected in the configurator when ordering a drive or power converter, or alternatively, they can be activated later by a proof-of-purchase token.

Table 3: PROFINET Model Codes

Model code	Description
+BAPR	PROFINET RT OS7PR

PROFINET is the Ethernet-based automation standard of PROFIBUS and PROFINET International (PI) for the implementation of an integrated and consistent automation solution based on Industrial Ethernet. PROFINET supports the integration of distributed field devices and time-critical applications in switched Ethernet networks. It also supports the integration of component-based distributed automation systems for vertical and horizontal integration of networks.

Table 4: PROFINET Features

Feature	Technical data
Cyclic response	1 ms update cycle
	PROFINET RT Conformance Class B (CC-B)
	Data consistency with submodule
Diagnostics	PROFINET Extended Diagnostics
	PROFINET Diagnostics (ALARM CR)
Connection	MRP (Media Redundancy Protocol)
	LLDP/SNMP
	Netload Class III, Advanced robustness against net load
	IPv4
	Addressing mode: DCP, STATIC, DHCP/BOOTP
System integration	GSDML files for iC7-Marine application software are available at https://www.danfoss.com/en/products/dds/system-modules/ic7-system-modules/ic7-marine/#tab-software . For information regarding the integration into 3rd party PROFINET-IO controller systems, see the application guides on https://www.danfoss.com .
PROFIenergy	Version 1.3

2.2 Communication Profiles and Objects

2.2.1 Overview

The iC7 series complies with PROFINET and PROFIdrive standards, mandatory PNU objects, PROFINET Extended Diagnostics, and a range of vendor-specific profiles for product-specific applications.

Communication profiles are selected in parameter **Fieldbus Profile** (1301).

Table 5: Communication Profiles and Supported Applications

Profile	Propulsion & Machinery	Active Front End
iC Generic	X	–
iC Speed	X	–
PROFIdrive Application Class 1	X	–
PROFIdrive version 1.3	X	X
PROFIdrive standard PNU's	X	X
iC Active Front End Profile	–	X

2.2.2 iC Speed Profile

2.2.2.1 Overview

The iC Speed profile is used with the iC7 series motor applications. The iC Speed profile differs from the PROFIdrive profile, because it does not have a state machine. It is only controlled by the actual state 1/0 of the control bits, not the sequence in which they are manipulated.

2.2.2.2 Control Word

Table 6: iC Speed Profile Control Word Bits

Bit number	Name	Description
0+1	Preset reference selector	00: Preset reference 1 01: Preset reference 2 10: Preset reference 3 11: Preset reference 4
2	Reserved	Reserved for future use. Any control words sent to the device should keep this bit at 0 to ensure compatibility with future extensions of the control word.
3	No coast/Coast	0: Causes the drive to immediately coast the motor. 1: No function.
4	No quick stop/Quick stop	0: Quick stops the drive and ramps down the motor speed to stop as defined with the quick stop ramp parameter. 1: No function.
5	No hold/Hold output frequency	0: Hold the present output frequency (in Hz). 1: No function.
6	Start/No start	0: Stops the drive and ramps down the motor speed as defined with the ramp-down parameter. 1: If the other starting conditions are fulfilled, this selection allows the drive to start the motor.
7	Reset	0: No function. 0 ⇒ 1: Reset faults. ⁽¹⁾
8	Jog/No jog	0: No function. 1: Sets the output frequency to the jog speed defined with the jog speed parameter.

Table 6: iC Speed Profile Control Word Bits - (continued)

Bit number	Name	Description
9	Ramp select	0: Ramp 1 is active. 1: Ramp 2 is active.
10	Data valid	0: Ignore the current process data. This is linked to the submodule where the CTW is present. If signals are to be covered, the CTW/STW profile (for example, the iC Speed profile) must be part of the signals list. 1: Use process data (controlled by PLC). Use the previously processed data when the data valid bit was true (no control by PLC).
11	Reserved	Reserved for future use.
12	User-defined	These bits are reserved for application-specific advanced control. Select the value CTW bit x for any input parameter to use this signal for the activation of a selected function. For more information, refer to the <i>Parameter Descriptions</i> chapter in the application guide.
13	User-defined	
14	User-defined	
15	User-defined	

1) Edge-triggered from 0 to 1 to reset the fault.

2.2.2.3 Status Word

Table 7: iC Speed Profile Status Word Bits

Bit number	Name	Description
0	Control Ready	0: The device controls are not ready and do not react to process data. 1: The device controls are ready and react to process data.
1	Drive Ready	0: The drive is not ready for operation. 1: The drive is ready for operation.
2	Coast	0: There is an active coast stop command and the drive is in a coast stop state. 1: There are no active coast signals. The drive can be started.
3	Fault	0: There are no active faults. 1: There is at least 1 active fault. The drive cannot be started before the fault condition is cleared and the fault is reset.
4	–	Reserved
5	–	Reserved
6	–	Reserved
7	Warning	0: There are no active warnings. 1: There is at least 1 active warning. The cause of the warning should be investigated and mitigated.
8	Speed Reference	0: Speed not at reference. The motor speed differs from the given speed reference, for example, due to ramping. 1: Speed at reference. The motor speed matches the given speed reference.

Table 7: iC Speed Profile Status Word Bits - (continued)

Bit number	Name	Description
9	Fieldbus Control	0: Fieldbus control inactive. None of the basic command functions of the drive are affected by fieldbus commands. 1: Fieldbus control active. Fieldbus is the active control place, or configured as part of the advanced control place.
10	Limiter	0: Limiter inactive. All limiters (regulators) are inactive. 1: Limiter active. One or more limiters (regulator) are actively limiting the drive current, torque, and so on. See parameter <i>Motor Regulator Status Word</i> (1715) for further details.
11	Operation	0: The drive is not modulating (operating). 1: The drive is modulating (operating).
12	–	Reserved
13	–	Reserved
14	–	Reserved
15	–	Reserved

2.2.3 iC Generic

2.2.3.1 Overview

The iC Generic profile is used for motor control operation with iC7 application software.

2.2.3.2 Control Word

Table 8: iC Generic Profile Control Word Bits

Bit	Name	Description
0	Ramp Stop	0: The ramp stop request is inactive. The drive can be started. 1: The drive is ready to operate.
1	Coast Stop	0: A running drive coasts to a stop (modulation stops). 1: The coast request is inactive. The drive can be started.
2	Quick Stop	0: The drive stops with the Quick Stop function. 1: The Quick Stop request is inactive. The drive can be started.
3	Start	0: The drive stops operating with the method determined by the parameter <i>Missing Start Response</i> (4717). 1: The drive starts to operate on the rising edge of this signal.
4	–	Reserved
5	–	Reserved
6	–	Reserved
7	Event Reset	0: Event Reset Inactive. 1: Event Reset Active. A rising edge of this signal resets events (warnings, faults, and so on), which do not have active triggering conditions. After a fault the drive goes to a Switching On Inhibited state, which must be acknowledged with bit 0.

Table 8: iC Generic Profile Control Word Bits - (continued)

Bit	Name	Description
8	Reference Reverse	0: The speed reference remains normal. 1: The speed reference is reversed. The reference can also be reversed with a negative setpoint. Double negatives result in a forward reference.
9	–	Reserved
10	Data Valid	0: Ignores the current process data. Uses the previously processed data when the Data Valid bit was previously true. 1: Reads the current process data. For most of the control word commands to be acknowledged by the drive, fieldbus must be the commanding control place. See options in parameter group Control Places in parameter group 2 Parameters .
11	Watchdog	0: Watchdog low. 1: Watchdog high. Continuous toggling 0–1 can be used as a sign of life between the drive and the fieldbus master. The value of this bit is also passed through the fieldbus status word as is.
12	Fieldbus Digital Input 1	0: Fieldbus Digital Input 1 inactive. 1: Fieldbus Digital Input 1 active. Select the value CTW B12 for any input parameter to use this signal for the activation of a selected function.
13	Fieldbus Digital Input 2	0: Fieldbus Digital Input 2 inactive. 1: Fieldbus Digital Input 2 active. Select the value CTW B13 for any input parameter to use this signal for the activation of a selected function.
14	Fieldbus Digital Input 3	0: Fieldbus Digital Input 3 inactive. 1: Fieldbus Digital Input 3 active. Select the value CTW B14 for any input parameter to use this signal for the activation of a selected function.
15	Fieldbus Digital Input 4	0: Fieldbus Digital Input 4 inactive. 1: Fieldbus Digital Input 4 active. Select the value CTW B15 for any input parameter to use this signal for the activation of a selected function

2.2.3.3 Status Word

Table 9: iC Generic Profile Status Word Bits

Bit	Name	Description
0	Ready To Switch On	0: The drive is not ready to receive a start command because of at least 1 of the following conditions is true: Fault Active, Ramp Stop Active, Coast Stop Active, or Quick Stop Active. 1: The drive is ready to accept a start command.
1	Power Unit Ready	0: The drive cannot be set running because the ready conditions of the power unit are not met. Check parameter Motor Control Start Ready Status Word (6207) for any conditions that are not met. 1: All power unit ready conditions are met.
2	Drive Running	0: The drive is not running. 1: The drive is running.
3	Fault Active	0: No active drive faults. 1: One or more drive faults are active. Switching on is inhibited.
4	–	Reserved
5	Quick Stop Active	0: The quick stop command is inactive. A new start command is required. 1: The quick stop command is active. This command can also be given from another control source than fieldbus.
6	–	Reserved
7	Warning Active	0: All drive warnings are inactive. 1: One or more drive warnings are active.
8	–	Reserved
9	Fieldbus Control Active	0: Fieldbus is not the active control place. 1: Fieldbus is the active control place.
10	–	Reserved
11	Run Enabled	0: The digital input signal Run Enable Input (103) is inactive, and modulation is disabled. 1: The digital input signal Run Enable Input (103) is active, and modulation is enabled.
12	–	Reserved
13	–	Reserved
14	–	Reserved
15	Watchdog Feedback	0: The watchdog signal that the drive has received is low. 1: The watchdog signal that the drive has received is high.

2.2.4 PROFIdrive - Standard Telegram 1

2.2.4.1 Overview

Standard telegram 1 is implemented according to PROFIdrive Application Class 1 profile as defined in the PROFIdrive standard and state machine diagram. It can be used with iC7 series motor applications.

2.2.4.2 Control Word

Table 10: Control Word Bits in PROFIdrive Standard Telegram 1

Bit number	Name	Description
0	On-Off	0: Off. 1: On.
1	Coast stop	0: Coast stop. 1: No coast stop.
2	Quick stop	0: Quick stop. 1: No quick stop.
3	Operation	0: Disable operation. 1: Enable operation.
4	Ramp generator	0: Reset ramp generator. The output of the RFG is set to 0. The drive decelerates along the current limit or along the voltage limit of the DC link. 1: Enable ramp generator (RFG).
5	Freeze	0: Freeze ramp generator. Freezes the present output frequency (in Hz). 1: Unfreeze ramp generator.
6	Enable setpoint	0: Disable setpoint. 1: Enable setpoint.
7	Fault acknowledge	0: No function. 0 ⇒ 1: Acknowledge faults. ⁽¹⁾
8	Jog 1	0: Jog 1 off. 1: Jog 1 on. Operation is enabled, drive is at standstill, and STW1 bit 4, 5, 6: 0. The drive runs up along the ramp to jogging setpoint 1.
9	Jog 2	0: Jog 2 off. 1: Jog 2 on. Operation is enabled, drive is at standstill, and STW1 bit 4, 5, 6: 0. The drive runs up along the ramp to jogging setpoint 2.
10	Control by PLC	0: Ignores the current process data. This is linked to a submodule where the CTW is present. If signals are to be covered, the CTW/STW profile (for example, the iC Speed Profile) must be part of the signals list. 1: Uses process data (controlled by PLC).
11	–	Reserved
12	User-defined	These bits are reserved for application-specific advanced control. For more information, refer to the <i>Parameter Descriptions</i> chapter in the application guide.
13	User-defined	
14	User-defined	
15	User-defined	

1) Acknowledging is edge-triggered, when changing from logic 0 to logic 1.

2.2.4.3 Status Word

Table 11: Status Word Bits in PROFIdrive Standard Telegram 1

Bit number	Name	Description
0	Ready to switch on	0: Not ready to switch on. 1: Ready to switch on.
1	Ready to operate	0: Not ready to operate. 1: Ready to operate.
2	Operation enabled	0: Operation disabled. 1: Operation enabled.
3	Operation fault	0: No fault. 1: Fault present.
4	Coast stop	0: Coast stop activated (OFF2). 1: Coast stop not activated (No OFF2).
5	Quick stop	0: Quick stop activated (OFF3). 1: Quick stop not activated (No OFF3).
6	Switching on inhibited	0: Switching on not inhibited. 1: Switching on inhibited.
7	Warning	0: There are no warnings. 1: A warning has occurred.
8	Speed error within/out of tolerance range	0: The motor runs, but the present speed is more than 1% different from the reference. It could, for example, be the case while the speed ramps up/down during start/stop. 1: The present motor speed matches the present speed reference within 1% of motor nominal speed.
9	Fieldbus control active/inactive	0: The device does not react on commands from fieldbus. ⁽¹⁾ 1: The device is controlled and reacting to I/O and process data.
10	Speed reached/Speed not reached	0: The actual speed is below the comparison value set with parameter Limit Supervision 1 Threshold (5253). 1: The actual speed is above the comparison value set with parameter Limit Supervision 1 Threshold (5253).
11	Reserved	Reserved
12	Reserved	Reserved
13	Reserved	Reserved
14	Reserved	Reserved
15	Reserved	Reserved

1) The reason why the device does not react to commands can be:

- Fieldbus is not the active control place.
- Fieldbus signals are not configured to be part of the Advanced Control Place.

2.2.4.4 PROFIdrive State Machine

In the PROFIdrive control profile, the control bits perform different functions:

- 0–3 perform the basic startup and power-down functions.
- 4–10 perform application-oriented control.

- 12–15 can be configured for different purposes.

See [Figure 1](#) for the basic state transition diagram, where control bits 0–3 control the transitions and the corresponding status bit indicates the actual state. The black dots indicate the priority of the control signals. Fewer dots indicate lower priority, and more dots indicate higher priority.

The general state diagram is defined in the PROFIdrive standard.

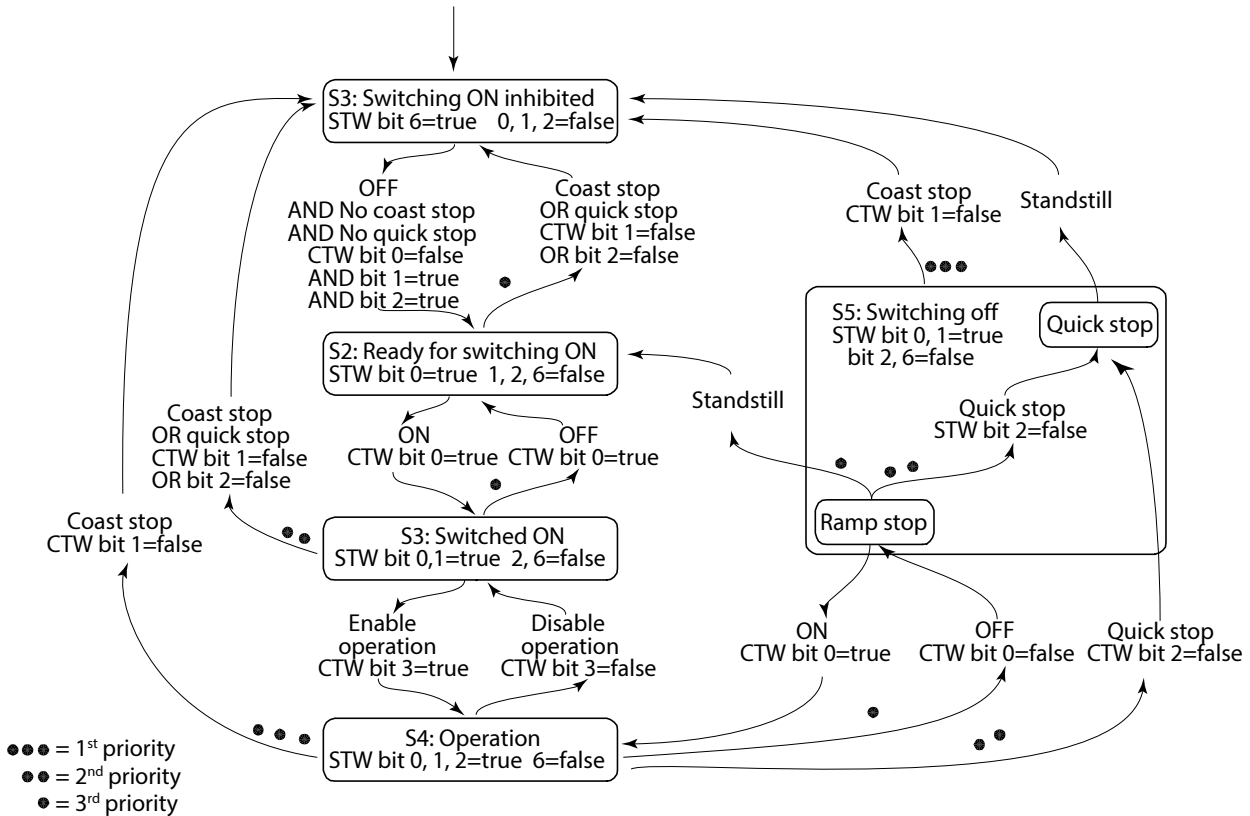

Figure 1: General State Diagram

2.2.5 iC Active Front End

2.2.5.1 Overview

The iC Active Front End profile is used in the iC7 series with the Active Front End application.

2.2.5.2 Control Word

Table 12: iC Active Front End Profile Control Word Bits

Bit number	Name	Description
0	Switch On Enabled	0: DC-link pre-charging, MCB closure, and running are prevented/interrupted. MCB is opened if closed. 1: DC-link pre-charging, MCB closure, and running are not prevented/interrupted. MCB is not opened if closed.
1	MCB Close Enabled	0: If pre-charging is completed, the MCB is not allowed to close. Running is also prevented or interrupted. MCB is opened if closed. 1: If pre-charging is completed, the MCB is allowed to close.
2	Quick Stop Inverse	0: Initiate quick stop. 1: Do not initiate quick stop.

Table 12: iC Active Front End Profile Control Word Bits - (continued)

Bit number	Name	Description
3	Start	<p>0: Stop the unit if it is running, or stop the pre-charging sequence if it is not completed.</p> <p>1: Start running if already precharged. Otherwise initiate pre-charging and then start running.</p> <p>Use the parameter <i>Fieldbus Start Mode</i> (5114) to configure whether a new start command is required after the unit has been stopped, or whether the unit starts running immediately after all stopping conditions (quick stop, faults, and so on) are cleared.</p>
4	Pre-charge	<p>0: Stop the DC-link pre-charging, if ongoing.</p> <p>1: Start/continue the DC-link pre-charging.</p> <p>Only used when the DC-link pre-charging is not controlled externally.</p>
5	–	Reserved
6	–	Reserved
7	Fault Reset	<p>0: Do not reset faults.</p> <p>1: Reset active faults.</p> <p>A rising edge (a transition from false to true) on this bit issues a fault reset request.</p>
8	–	Reserved
9	–	Reserved
10	Data Valid	<p>0: Ignore the current incoming process data values, instead use the last processed value when <i>Data Valid</i> bit was true.</p> <p>1: Use the current incoming process data values.</p>
11	Watchdog	Incoming fieldbus watchdog bit. used for monitoring the fieldbus connection.
12	User-defined	<p>These bits are reserved for application-specific advanced control. Select the value <i>CTW bit x</i> for any input parameter to use this signal for the activation of a selected function. For more information, refer to the <i>Parameter Descriptions</i> chapter in the application guide.</p>
13	User-defined	
14	User-defined	
15	User-defined	

2.2.5.3 Status Word

Table 13: iC Active Front End Profile Status Word Bits

Bit number	Name	Description
0	Ready to Switch On	<p>0: The unit is not ready to run.</p> <p>1: The unit is ready to run.</p> <p>This bit indicates that the unit is ready to start the startup sequence, that is, pre-charging and/or MCB closure, if controlled by the application. There are no active faults and the Switch on Enabled bit is active.</p>
1	Converter Ready	<p>0: The unit is not ready to run.</p> <p>1: The unit is ready to run.</p> <p>When this bit is true, it indicates that the unit can be successfully started with the Start bit (bit 3) of the control word.</p>

Table 13: iC Active Front End Profile Status Word Bits - (continued)

Bit number	Name	Description
2	Running	0: The unit is not running (modulating). 1: The unit is running (modulating).
3	Fault	0: No faults active. 1: One or more faults active.
4	--	Reserved
5	Quick Stop Inverse	0: Quick stop is active. 1: Quick stop not active.
6	--	Reserved
7	Warning	0: No active warnings. 1: One or more warnings are active.
8	--	Reserved
9	Control by PLC	0: Fieldbus is not the active control place. 1: Fieldbus is the active control place.
10	--	Reserved
11	Run Enabled	0: Run enable from a dedicated input signal is missing. 1: Run enable from a dedicated input signal is present. This bit indicates the state of parameter <i>Run Enable Input</i> (103)
12	--	Reserved
13	--	Reserved
14	--	Reserved
15	Watchdog	Outgoing fieldbus watchdog bit, mirroring control word bit Watchdog (bit 11).

2.3 Submodules

In the iC7 series, the exchange of process data values is done through submodules:

- Profile signals
- Process data input and output signals. The available signal content can be browsed in the iC7-Marine device description files (see [4.6 GSDML File \(Device Description File\)](#) for further information).

Table 14: Submodule Sizes

Application	Cyclic input data	Cyclic output data
iC Generic	[STW] [MAV]	[CTW] [REF]
PROFIdrive Standard telegram 1	[STW] [MAV]	[CTW] [REF]
iC Speed Profile	[STW] [MAV]	[CTW] [REF]
CTW2/STW2	[STW2]	[CTW2]
iC Active Front End Profile	[STW] [MAV]	[CTW] [REF]

Table 15: Signal Module Sizes

Application	Cyclic input data	Cyclic output data
Propulsion & Machinery	4 signals (16 bytes)	4 signals (16 bytes)
	8 signals (32 bytes)	8 signals (32 bytes)
	12 signals (48 bytes)	12 signals (48 bytes)
	16 signals (64 bytes)	16 signals (64 bytes)
	20 signals (80 bytes)	20 signals (80 bytes)
Active Front End	4 signals (16 bytes)	–
	8 signals (32 bytes)	
	12 signals (48 bytes)	
	16 signals (64 bytes)	
	20 signals (80 bytes)	

Each of the selections in a signal module can comprise the following data types:

- Boolean
- Unsigned 8/16/32
- Signed 8/16/32
- Float32

The buffer size adapts to the data type of the selected signals. If a Boolean type is mapped, only bit 0 is used in the selected signal address, and the remaining 7 bits are not used.

The actual interpretation of the value that is read or written depends on the data type and representation. For example, motor current is a real-type 32-bit value that is represented as float, and publishing the motor current as an actual value does not need any scaling and factoring.

2.4 Functional Extension Options

Each functional extension option is defined by its own PROFINET device model with a module and submodule(s).

Slot 1 contains the application and the subsequent slots contain the installed options. Each option supports a module access point (MAP), and other submodules contain the process data.

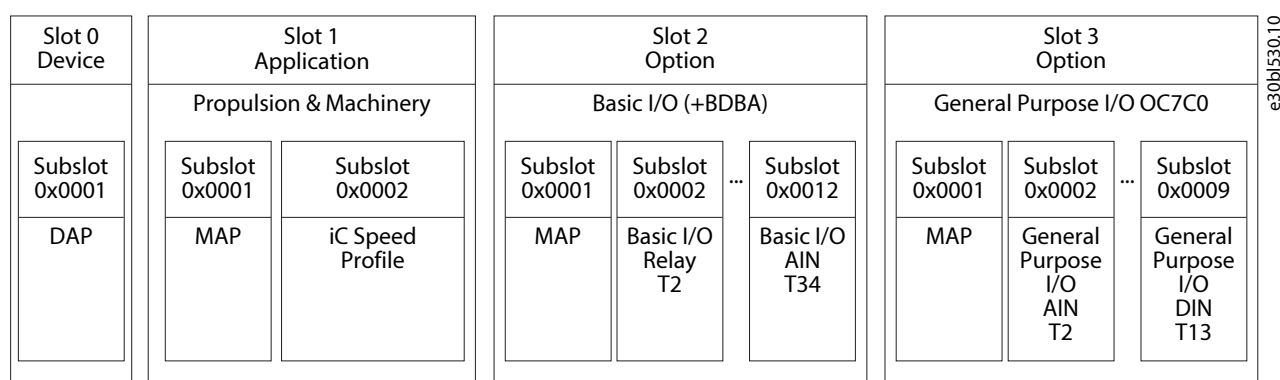

Figure 2: Example of a PROFINET Device Model with Functional Extension Options Installed in an iC7-Marine Drive

2.5 Network Topologies

2.5.1 Overview

Communication interface X1/X2 is used for fieldbus connection.

The communication interface in the iC7 drives and power converters has 2 Ethernet ports (X1 and X2) and an embedded switch with 2 Ethernet RJ45 connectors. It has 1 MAC and IP address, and is considered a single device in the network. The communication interface supports 3 network topologies:

- Line topology
- Star topology
- Ring topology

2.5.2 Line Topology

In many applications, line topology enables simpler cabling and the use of fewer Ethernet switches. Observe network performance and the number of devices in a line topology. Too many devices in a line may exceed network update time limits.

NOTICE

When line topology is used, take precautions to avoid timeout in the PLC when more than 8 drives or power converters are installed in series. Each drive or power converter in the network adds a small delay to the communication due to the built-in Ethernet switch. When the update time is too short, the delay can lead to a timeout in the PLC.

- Set the update time as shown in the table. The numbers given are typical values and can vary from installation to installation.

Number of units connected in series	Minimum update time [ms]
<8	2
8–16	4
16–32	8
33–50	16
>50	Not recommended



NOTE: Using tools such as MyDrive® Insight may influence system performance in a line topology.

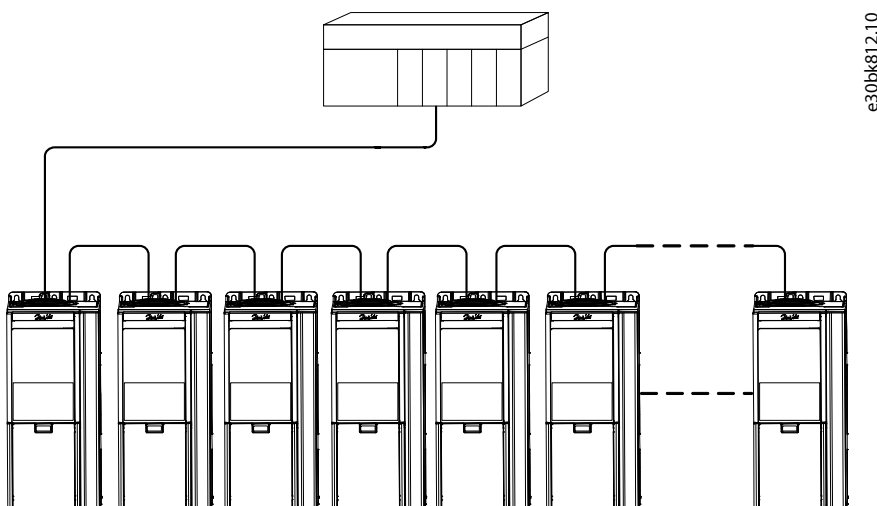

e30bk812.10

Figure 3: Example of Line Topology

NOTICE

Installing drives or power converters of different current ratings in line topology may result in unwanted fieldbus timeout messages in the event log.

- Mount the drives or power converters with the longest discharge time first in the line topology. In normal operation, the drives or power converters with bigger current ratings have a longer discharge time.

2.5.3 Star Topology

In a star network, all devices are connected to the same switch or switches. Star topology reduces the damage caused by a single cable failure. In a star topology, a single cable failure affects a single device instead of all devices in the network. In many applications, this topology enables simpler cabling depending on the location and distance of the device.

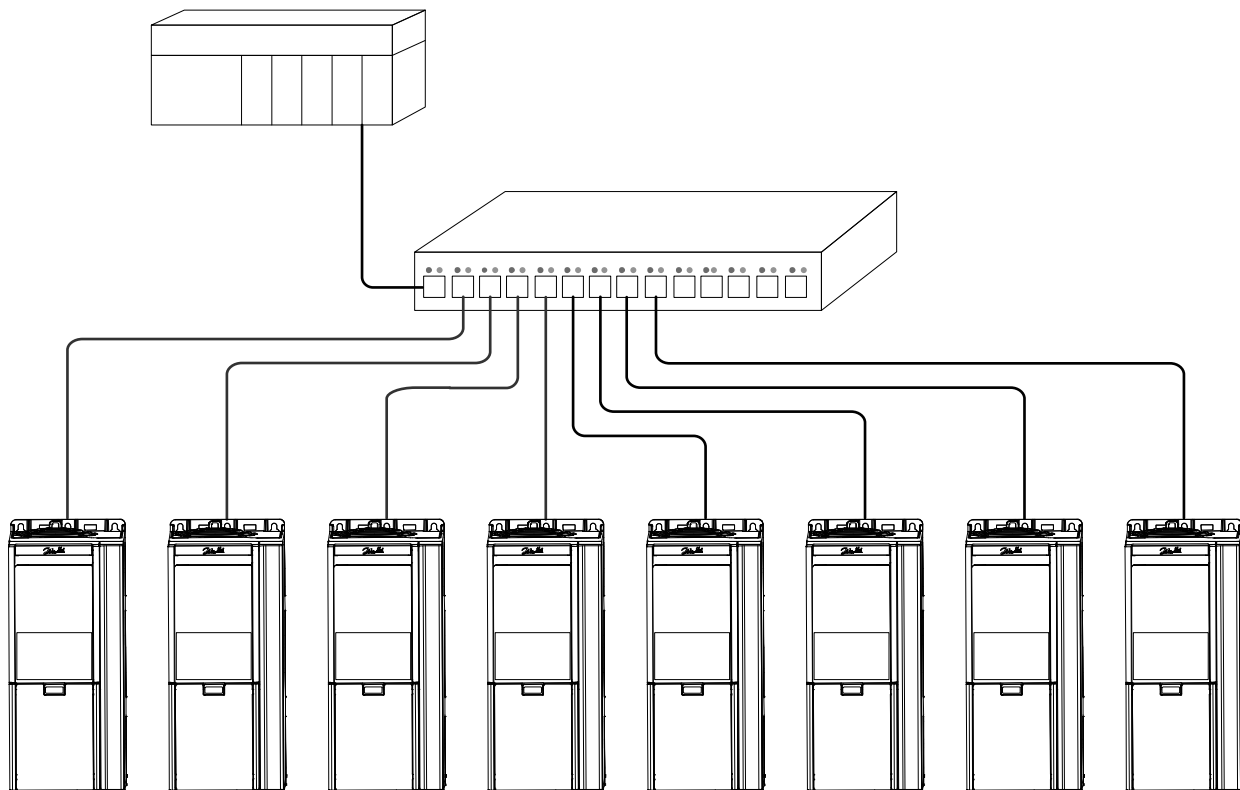

e30bk813.10

Figure 4: Example of Star Topology

2.5.4 Ring Topology

Ring topology enables the same simpler cabling and reduced cabling costs as line topology, but also reduces the damage caused by a single cable failure in a similar manner as star topology.

NOTICE

When ring topology is used, take precautions to avoid timeout in the PLC when more than 8 drives or power converters are installed in series. Each drive or power converter in the network adds a small delay to the communication due to the built-in Ethernet switch. When the update time is too short, the delay can lead to a timeout in the PLC.

- Set the update time as shown in the table. The numbers given are typical values and can vary from installation to installation.

Number of units connected in series	Minimum update time [ms]
<8	2
8–16	4
16–32	8
33–50	16
>50	Not recommended

The ring topology protocol depends on the protocol in use.

For PROFINET, the Media Redundancy Protocol (MRP) is used. The MRP is designed to react deterministically on a cable failure. One of the nodes in the network has the role of Media Redundancy Manager (MRM), which observes and controls the ring topology to react to network faults. Usually this device is a PLC or network switch.

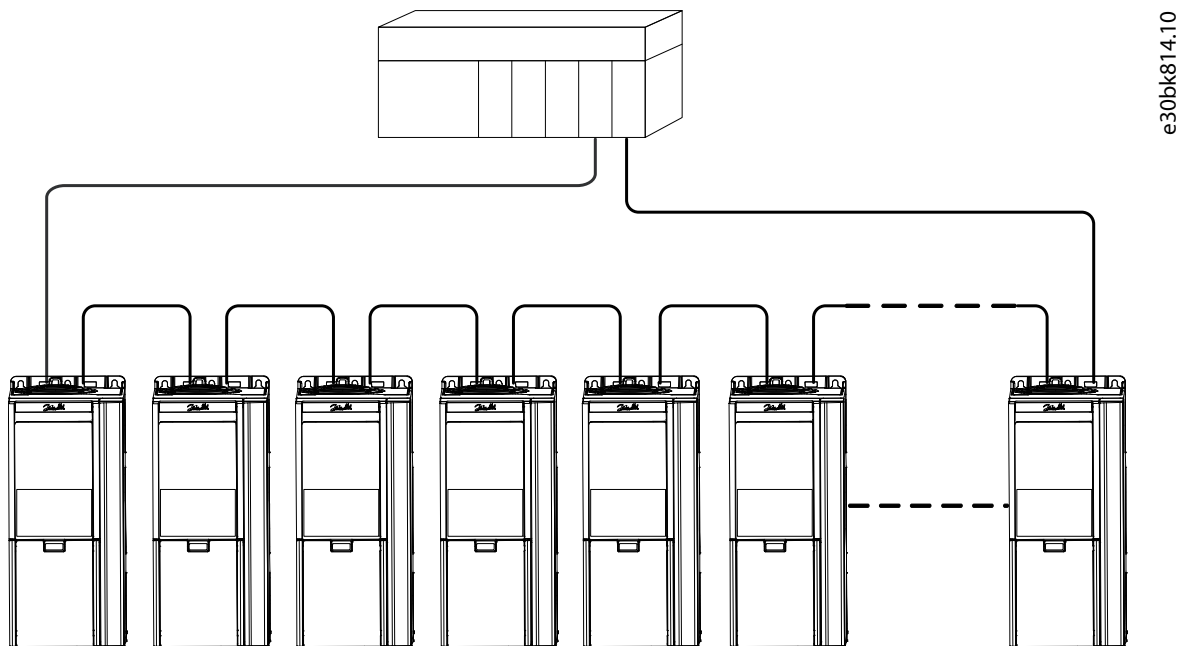

Figure 5: Example of Ring Topology

3 Fieldbus Cable Connections

3.1 Prerequisites for Installation

Communication interfaces are integrated in the control board in iC7 drives and power converters.

The position of the connections differs based on the control board concept and frame, for example. For more information on the location of the connections, cabling, and shielding, refer to the product-specific design guide.

3.2 Installation in Frequency Converters

3.2.1 Communication Interface X1/X2 in Frames FA02–FA12

The communication interface is on the top of the frequency converter as shown in [Figure 6](#). Industrial-grade RJ45 connectors are recommended for optimal connection. A combined shield/fixing plate, the Fieldbus EMC plate, is available as an accessory to strengthen the mechanical fixation of the cables. For information on ordering the EMC plate, refer to the product-specific design guide.

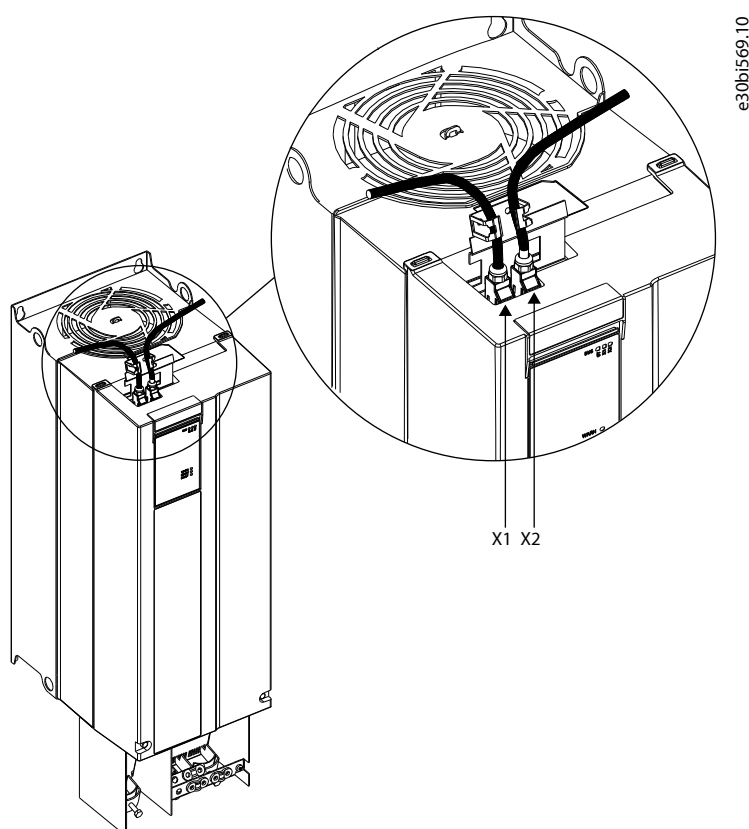

Figure 6: Location of the Communication Interface, X1/X2 in FA02-FA12 Frames (with the Optional EMC Plate)

3.2.2 Communication Interface X1/X2 in Frames FB09–FB12/FK06–FK12

The communication interface ports are located inside the frequency converter. The position of the ports and the recommended wiring path are shown in [Figure 7](#) and [Figure 8](#).

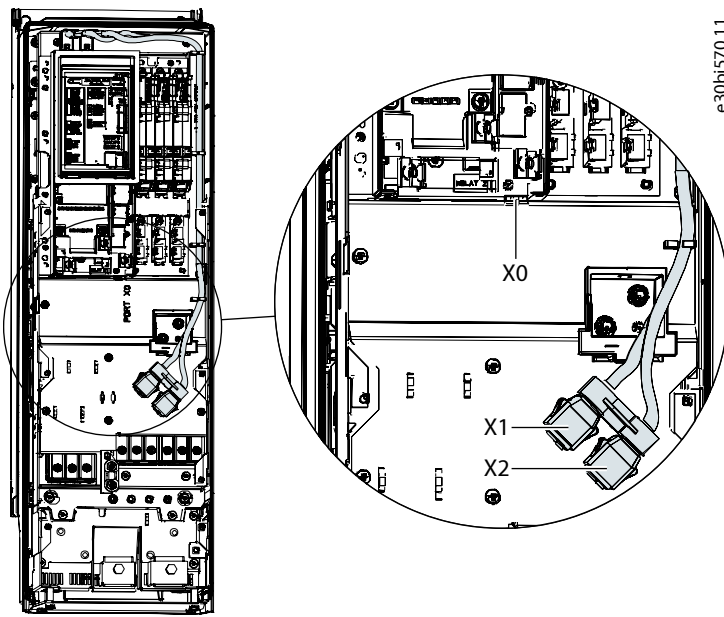

Figure 7: Communication Port X0, X1, and X2 Locations in FK06–FK08 Frames

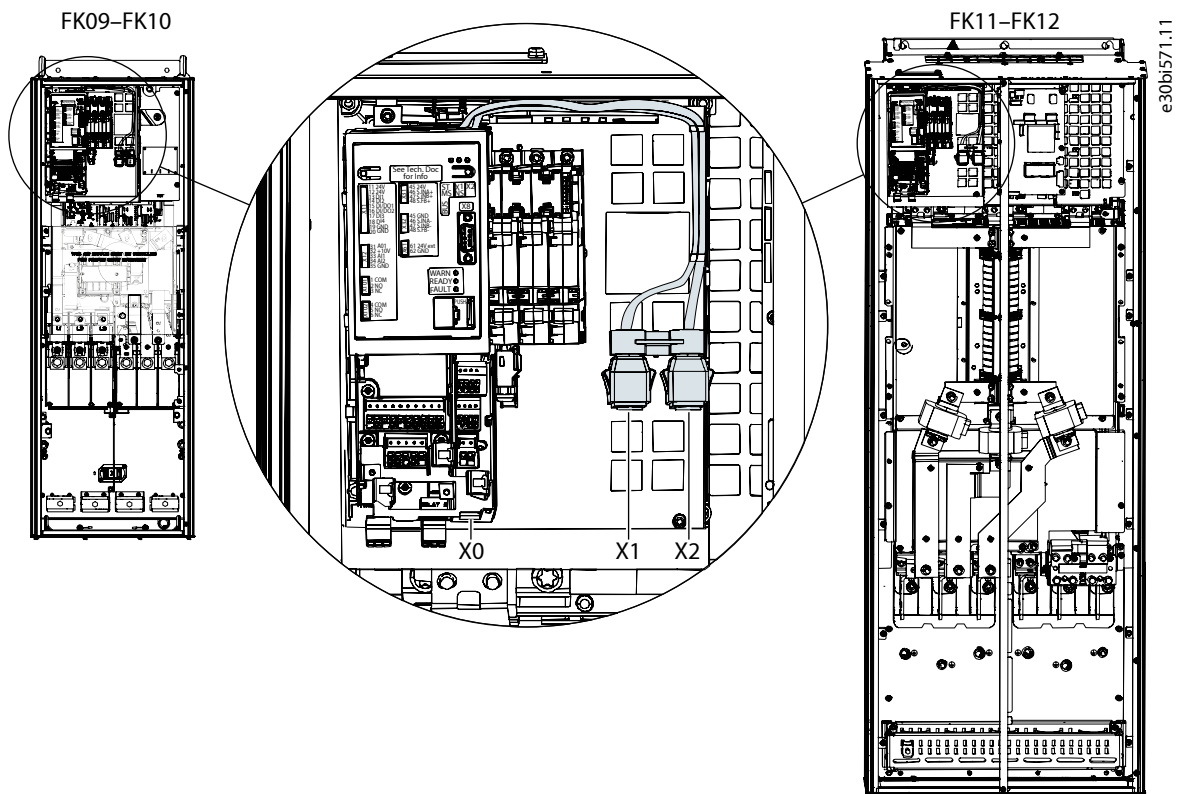

Figure 8: Communication Port X0, X1, and X2 Locations in FB09–FB12/FK09–FK12 Frames

3.3 Installation in System Modules

3.3.1 Communication Interface X1/X2 in System Modules

For systems that use system modules, the communication interface ports are located at the bottom facing side of the modular control unit as shown in [Figure 9](#).

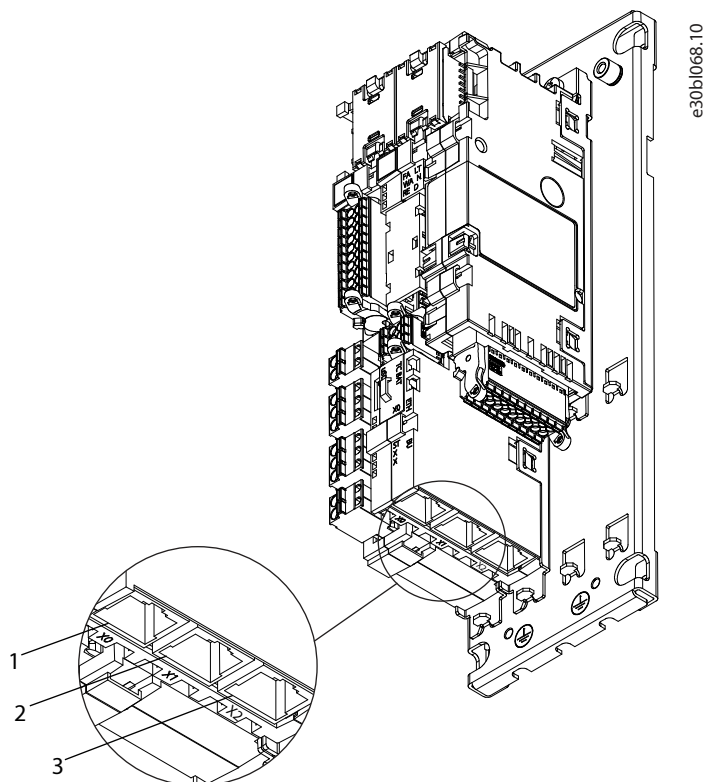

Figure 9: Communication Port X0, X1, and X2 Locations in the Modular Control Unit

1	Ethernet port (X0)	2	Ethernet port (X1)
3	Ethernet port (X2)		

3.4 EMC-compliant Installation

3.4.1 Overview

To obtain an EMC-compliant installation, follow the instructions provided in the product-specific design guide and the installation guide included in the shipment.

3.4.2 Grounding

- Ensure that all stations connected to the fieldbus network are connected to the same ground potential. When distances between the stations in a fieldbus network are long, connect the individual station to the same ground potential. Install equalizing cables between the system components.
- Establish a grounding connection with low HF impedance, for example, by mounting the unit on a conductive backplate.
- Keep the ground wire connections as short as possible.

3.4.3 Cable Routing

For more information on cabling, refer to the product-specific design guide and installation guide included in the shipment.

NOTICE

EMC INTERFERENCE

Failure to isolate fieldbus communication, motor, and brake resistor cables can result in unintended behavior or reduced performance.

- Use shielded cables for motor and control wiring, and separate cables for fieldbus communication, motor wiring, and brake resistor.
- A minimum of 200 mm (7.9 in) clearance between power, motor, and control cables is required. For power sizes above 315 kW (450 hp), increase the minimum distance to 500 mm (20 in).

NOTICE

CABLE ROUTING

- When the fieldbus cable intersects with a motor cable or a brake resistor cable, ensure that the cables intersect at an angle of 90°.

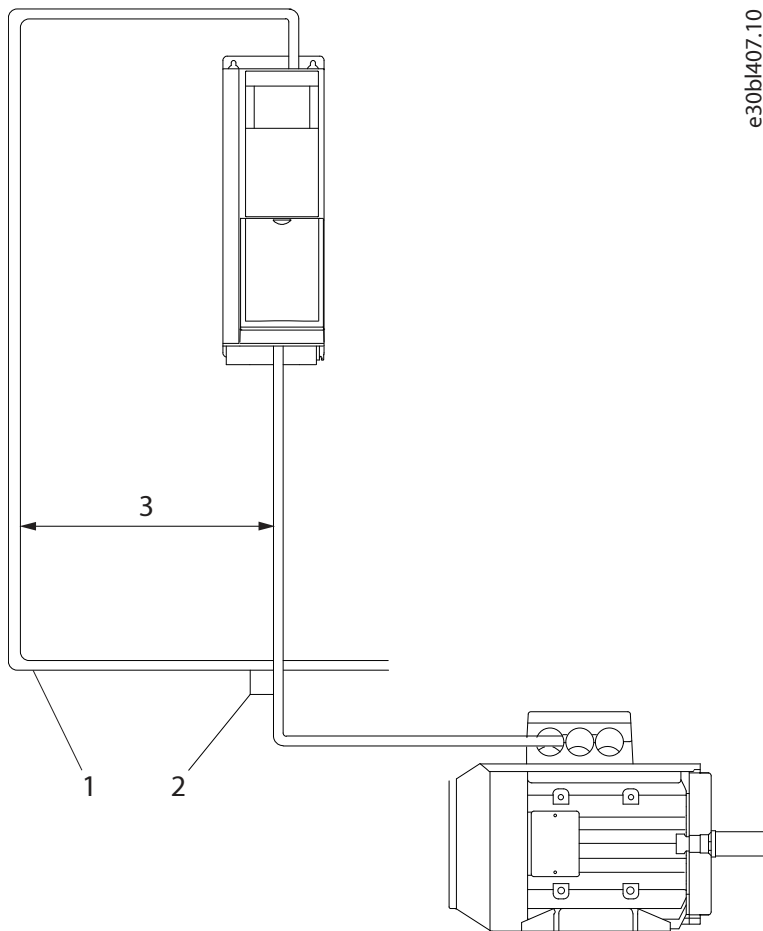

Figure 10: Cable Routing

1	Fieldbus cable	2	90° intersection
3	≥200 mm (7.9 in) (≥ 500 mm (20 in) for power sizes >315 kW (450 hp))		

4 Configuration

4.1 Selecting the Fieldbus Profile

For more information about the available profiles for the application in use, see [Communication Profiles and Objects](#).

1. Navigate to *Parameters > Control Places > Fieldbus Control > Fieldbus Profile*.
2. Select the fieldbus profile.

The selection affects the interpretation of the control word and status word. Selecting a profile may also automatically set specific values for certain parameters or affect control schemes. For details, refer to the application guide.

4.2 Configuring Fieldbus Protection Settings for the Propulsion & Machinery Application

1. Navigate to parameter group *Parameters > Protections and Responses > Fieldbus Protections*.
2. Configure fieldbus protection settings.

Table 16: Fieldbus Protection Setting Parameters for the Propulsion & Machinery Application

Parameter	Parameter number	Value	Description
<i>Fieldbus Fault Response</i>	1303	<ul style="list-style-type: none"> • No response • Info (default) • Warning • Fault, ramp to coast • Fault, coast See Table 17 for descriptions of the events.	Select the behavior when a fieldbus fault, for example, loss of I/O connection occurs.
<i>Process Data Timeout Response</i>	5291	<ul style="list-style-type: none"> • No response • Info (default) • Warning • Fault, ramp to coast • Fault, coast See Table 17 for descriptions of the events.	Select the response to a process data timeout.
<i>Process Data Timeout Delay</i>	1340	0.05–18000 s (Default value: 1.00 s)	Set a delay for the triggering of the Process Data Timeout event. If process data has not been updated within this delay time, the event is triggered.
<i>Fieldbus Watchdog Response</i>	5244	<ul style="list-style-type: none"> • No response (default) • Info • Warning • Fault, ramp to coast • Fault, coast See Table 17 for descriptions of the events.	Select the drive response for the fieldbus watchdog event.

Table 16: Fieldbus Protection Setting Parameters for the Propulsion & Machinery Application - (continued)

Parameter	Parameter number	Value	Description
<i>Fieldbus Watchdog Delay</i>	5245	0.0–3000.0 s (Default value: 5.00 s)	Set a delay for activating the fieldbus watchdog event.
<i>Fieldbus Watchdog Start Delay</i>	5246	0.0–3000.0 s (Default value: 30.00 s)	Set the startup delay time for activating the fieldbus watchdog event. The counter starts when drive wakes up.
<i>FB Monitoring Control Place Dependency</i>	1338	<ul style="list-style-type: none"> Disabled Enabled (default) 	Set the control place dependency for fieldbus monitoring functions (Fieldbus Fault, Process Data Timeout, and Fieldbus Watchdog). When enabled, the monitoring functions are active only in the fieldbus control place. When disabled, the functions are active regardless of the control place.

Table 17: Event Descriptions in the Propulsion & Machinery Application

Value	Description
No response	–
Info	The event is logged in the event log.
Warning	The drive or power converter issues a warning.
Fault, ramp to coast	The drive or power converter issues a fault, and ramps the motor speed to zero before stopping modulation.
Fault, coast	The drive or power converter issues a fault and stops modulation immediately.

4.3 Configuring Fieldbus Protection Settings for the Active Front End Application

When using the iC7 series Active Front End application, the fieldbus profile is selected automatically.

1. Navigate to parameter group *Parameters > Protections and Responses > Fieldbus Protections*.
2. Configure fieldbus protection settings.

Table 18: Fieldbus Protection Setting Parameters for the Active Front End Application

Parameter	Parameter number	Value	Description
Fieldbus Fault Response	1304	<ul style="list-style-type: none"> No response Info Warning Fault (default) Fault, open MCB See Table 19 for descriptions of the events.	Select the behavior when a fieldbus fault, for example, loss of I/O connection occurs.
No Fieldbus Connection Response	1305	<ul style="list-style-type: none"> No response (default) Info Warning Fault Fault, open MCB See Table 19 for descriptions of the events.	Select the response if there is no fieldbus connection.
Process Data Timeout Response	1306	<ul style="list-style-type: none"> No response Info (default) Warning Fault Fault, open MCB See Table 19 for descriptions of the events.	Select the response to a process data timeout.
Process Data Timeout Delay	1340	0.05–18000 s (Default value: 1.00 s)	Set a delay for the triggering of the Process Data Timeout event. If process data has not been updated within this delay time the event is triggered.
Fieldbus Watchdog Response	5244	<ul style="list-style-type: none"> No response Info Warning (default) Fault Fault, open MCB See Table 19 for descriptions of the events.	Select the converter response for the fieldbus watchdog event.
Fieldbus Watchdog Delay	5245	0.0–3000.0 s (Default value: 5.00 s)	Set a delay for activating the fieldbus watchdog event.
Fieldbus Watchdog Start Delay	5246	0.0–3000.0 s (Default value: 30.00 s)	Set a startup delay time for activating the fieldbus watchdog event. The counter starts when the converter wakes up.

Table 19: Event Descriptions

Value	Description
No response	–
Info	The event is logged in the event log.
Warning	The drive or power converter issues a warning.
Fault	The drive or power converter issues a fault and stops modulation.
Fault, open MCB	The drive or power converter issues a fault, stops modulation, and opens the main circuit breaker.

4.4 Configuring the Ethernet Interface

The X1 and X2 interfaces are internally connected with an Ethernet switch and share the same physical MAC layer, and the same IP settings apply to both interfaces. IPv4 settings are configured in MyDrive® Insight or in the control panel.

1. Configure IPv4 settings.
 - In MyDrive® Insight, go to **Setup and Service > Interface configuration > Interface X1/X2 > IPv4 settings**.
 - In the control panel, navigate to parameter group **Communication Interfaces**.

Table 20: IPv4 Settings

Function	Value	Description
Interface X1/X2 MAC address	00:1B:08:xx:xx:xx	The MAC address of interface X1/X2. The value is read-only.
IPv4 addressing method	Disable	Only link-local IP address in the 169.254.xxx.xxx range is active.
	Static IP	A static IP address is entered manually.
	Automatic	IP address is assigned via a DHCP or BOOTP server.
	DCP (default)	DCP is used with PROFINET where a PLC assigns the IP address, subnet mask, and other relevant parameters.
Requested IPv4 address	xxx.xxx.xxx.xxx	If Automatic is selected as the IPv4 addressing method and no DHCP/BOOTP server is present, the X1/X2 interface automatically configures an IP address and subnet mask in the 169.254.xxx.xxx range.
Requested IPv4 subnet mask	xxx.xxx.xxx.xxx	The requested IPv4 subnet mask for the interface.
Requested IPv4 gateway address	xxx.xxx.xxx.xxx	Requested IPv4 gateway address for the interface.
Enable ACD	Enable	Request to enable or disable Address Conflict Detection for the interface.
	Disable (default)	The change does not take effect before a power cycle is performed. If no conflicts are detected, ACD activity shows 0. If an address conflict occurs, the ACD activity shows 1, and the IPv4 interface reverts to an automatically assigned IP address in the 169.254.xxx.xxx range. The recommended setting for PROFINET is Disable .
DNS server 1, 2	xxx.xxx.xxx.xxx	The user-requested Domain Name Server 1 for the interface (for manual IP addressing mode only).

4.5 Configuring Name of Station

1. Navigate to parameter **Name of Station** (7080).

Parameter name	Parameter number	Value	Additional information
Name of Station	7080	Accepted characters: <ul style="list-style-type: none"> • Lower case letters (a–z) • Numbers (0–9) • Special characters: dash (–), full stop (.) The value can be up to 127 characters or digits in total. The maximum length for each component separated by a full stop or dash is 63 characters or digits. Spaces are not allowed.	Each PROFINET device has a unique Name of Station.

4.6 GSDML File (Device Description File)

To configure a PROFINET controller, the configuration tool needs a GSDML file for each type of device in the network. The GSDML file is a PROFINET xml file containing the necessary communication setup data for a device. Each product in the iC7 series has a unique GSDML file.

Download the GSDML files for the iC7 series from <https://www.danfoss.com/en/service-and-support/downloads/dds/fieldbus-configuration-files/>. Check that the GSDML file version is compatible with the firmware version.

4.7 Reference and Main Actual Handling

4.7.1 Propulsion & Machinery Application

In the Propulsion & Machinery application, the Main Reference [REF] and the Main Actual Value [MAV] are tied to the motor speed. These variables are interfaced as signed 16-bit integer values and are both scaled linearly based on the signal and scale parameter pairs given in [Table 21](#).

Table 21: Reference Scaling Parameters

Parameter	Parameter number	Unit	Range	Data type
Fieldbus Speed Signal Max	6312	–	-32768–32767	Signed 16
Fieldbus Speed Signal Min	6313	–	-32768–32767	Signed 16
Fieldbus Speed Scale Max	6310	[Hz]	-1000–1000	Float 32
Fieldbus Speed Scale Min	6311	[Hz]	-1000–1000	Float 32

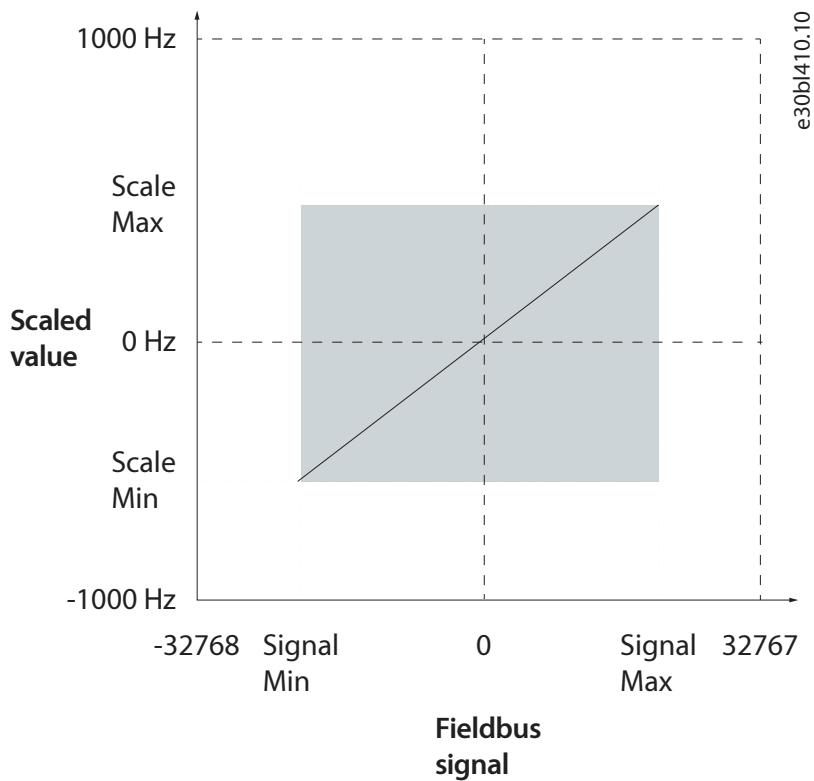

Figure 11: Example of Fieldbus Speed Reference

When the PROFIdrive Standard Telegram 1 profile is selected (parameter number 1301), these parameters are automatically set so that the following reference handling scheme is implemented:

- Signal Max = +32767 = 0x7FFF ↔ Scale Max = +199.99% of motor nominal speed (parameter number 402).
- Signal Min = -32768 = 0x8000 ↔ Scale Min = -200.00% of motor nominal speed (parameter number 402).

4.7.2 Active Front End Application

For the Active Front End application, the Main Reference [REF] and Main Actual Value [MAV] are tied to the DC-link voltage of the converter. Both of these signals are interfaced as 32-bit floating-point values. They are expressed in % of the **Grid Nominal Voltage** parameter (parameter number 6537).

5 Parameter Access

5.1 Overview

iC7 series supports access to parameters via Base Mode Parameter Access. The data mechanism transmits requests and replies acyclically. The requests and replies are transmitted by the Acyclic Data Exchange mechanism.

For detailed instructions on how to access parameters, refer to the documentation provided by the PLC manufacturer.

5.2 PROFIdrive Parameter Numbers

PROFIdrive specifies a list of standard PNUs and maps them to the areas defined in [Table 22](#). For more details on PROFIdrive PNUs, refer to the latest version of the PROFIdrive standard.

The iC7 series supports all mandatory PNU objects and some optional and the device-specific parameter access range. The PROFIdrive parameters are not accessible via MyDrive® Insight or the control panel.

Table 22: Supported PNUs

PNU	Description
922	Telegram selection
923	List of all parameters for signals
944	Fault message counter
947	Fault number
950	Scaling of the fault buffer
964	Drive unit identification
965	Profile identification number
972	Drive reset
974	Base mode parameter access service identification
975	Drive object identification
976	Load device parameter set
977	Transfer in non-volatile memory (global)
980–989	Number list of defined parameters
60000	Velocity reference value
61000	NameOfStation (read only)
61001	IpOfStation (read only)
61002	MacOfStation (read only)
61003	DefaultGatewayOfStation (read only)
61004	SubnetMaskOfStation (read only)

6 Troubleshooting

6.1 Diagnostics

The iC7 series supports diagnostic event messaging for control systems by using faults and warnings. The faults and warnings are enabled by default. Whenever one occurs, it is indicated on the display of a control system. If diagnosis interrupt is used by the control system, it is possible to read out the fault or warning event within the PLC program and to react accordingly.

Table 23: Diagnostics Parameters

Parameter name	Parameter number	Value	Description
Diagnostics Fault	7081	<ul style="list-style-type: none"> Enabled (default) Disabled 	Enables diagnostic fault. When disabled, the device does not send any PROFINET diagnosis message with severity Fault when a fault is present on the device.
Diagnostics Warning	7083	<ul style="list-style-type: none"> Enabled (default) Disabled 	Enables diagnostic warning. When disabled, the device does not send any PROFINET diagnosis message with severity Maintenance required when a warning is present on the device.

6.2 PROFINET Report

The PROFINET report is available in MyDrive® Insight. The report shows:

- Connections
- Configuration
- Mapped signals and their values

The report is a snapshot of the values from the time the report was created. It is not possible to see live data in the report.

PROFINET Status

Name: ic7
IP: 192.168.3.2

Connections

AR	State	Type	Count	Controller	Controller IP
1	Connected	Single	8	pn-io-simu-20	192.168.3.99
2	Not connected	-	0	0.0.0.0	
3	Not connected	-	0	0.0.0.0	
4	Not connected	-	0	0.0.0.0	

Module Configuration

Slot	Module	Subslot	Submodule	IOPS	IOCS
1	Industry Application	1	Module Access Point	GOOD	GOOD
1	Industry Application	2	IC speed profile	GOOD	GOOD
2	Basic I/O	1	Module Access Point	GOOD	GOOD
2	Basic I/O	2	Basic I/O Relay Terminal 2	-	-
2	Basic I/O	3	Basic I/O Relay Terminal 5	-	-
2	Basic I/O	4	Basic I/O Digital Input Status Word	GOOD	GOOD
2	Basic I/O	11	Basic I/O Analog Input Terminal 33 Voltage	GOOD	GOOD
3	General Purpose I/O OC7C0	1	Module Access Point	GOOD	GOOD
3	General Purpose I/O OC7C0	5	General Purpose I/O Digital Output T7	GOOD	GOOD
3	General Purpose I/O OC7C0	6	General Purpose I/O Digital Output T8	GOOD	GOOD
4	Relay OC7R0	1	Module Access Point	GOOD	GOOD
4	Relay OC7R0	2	Relay Terminal 2	GOOD	GOOD
4	Relay OC7R0	3	Relay Terminal 5	GOOD	GOOD
4	Relay OC7R0	4	Relay Terminal 8	GOOD	GOOD
5	Temperature Measurement OC7T0	1	Module Access Point	-	-
5	Temperature Measurement OC7T0	2	Temperature Input T4	-	-
0	Device Access Point	1	Device Access Point	GOOD	GOOD
0	Device Access Point	32768	Interface X1/X2	GOOD	GOOD
0	Device Access Point	32769	Port X1	GOOD	GOOD
0	Device Access Point	32770	Port X2	GOOD	GOOD

AR 1

Industry Application/IC speed profile Outputs

Signal	Name	Unit	Value	Value as hex
1335	Fieldbus Control Word	-	0x047C	0x047C
1339	Fieldbus Speed Reference 1	-	8192	0x2000

Industry Application/IC speed profile Inputs

Signal	Name	Unit	Value	Value as hex
1307	Fieldbus Status Word	-	0x0E07	0x0E07
1308	Fieldbus Speed Main Actual Value	-	7826	0x1E92

Basic I/O/Basic I/O Digital Input Status Word Inputs

Signal	Name	Unit	Value	Value as hex
1614	Digital Input Status	-	0x0002	0x0002

Basic I/O/Basic I/O Analog Input Terminal 33 Voltage Inputs

Signal	Name	Unit	Value	Value as hex
16110	Basic I/O T33	-	0	0x0000

General Purpose I/O OC7C0/General Purpose I/O Digital Output T7 Outputs

Signal	Name	Unit	Value	Value as hex
16124	General Purpose I/O T7	-	false	0x00

General Purpose I/O OC7C0/General Purpose I/O Digital Output T8 Outputs

Signal	Name	Unit	Value	Value as hex
16125	General Purpose I/O T8	-	false	0x00

Relay OC7R0/Relay Terminal 2 Outputs

Signal	Name	Unit	Value	Value as hex
16100	Relay T2	-	false	0x00

Relay OC7R0/Relay Terminal 5 Outputs

Signal	Name	Unit	Value	Value as hex
16101	Relay T5	-	false	0x00

Relay OC7R0/Relay Terminal 8 Outputs

Signal	Name	Unit	Value	Value as hex
16102	Relay T8	-	false	0x00

e30bk437.10

Figure 12: Example of a PROFINET Report

6.3 Configuring Port Mirroring Settings

Enable or disable the port mirroring function for network troubleshooting with a network analyzer tool.

1. In MyDrive® Insight, go to **Setup and Service > Interface Configuration > Port Mirroring Settings**.

Table 24: Port Mirroring Settings

Function	Selections	Description
Source port	<ul style="list-style-type: none"> • X1 • X2 	Frames are mirrored from this port.
Destination port	<ul style="list-style-type: none"> • X1 • X2 	Frames are mirrored to this port.
Block RX from destination port	Enable/Disable	Device does not receive any frames from Destination Port when enabled.
Enable port mirroring	Enable/Disable	Enables the Port Mirroring feature.

6.4 Identifying a Unit

The winking function makes the fieldbus indicator LEDs ST, X1, and X2 flash yellow to make it easy to identify a unit. The function is enabled in MyDrive® Insight.

1. In MyDrive® Insight, click the device name in live mode.
2. Select *Device Status*.
3. To activate or deactivate the feature, click the toggle switch.

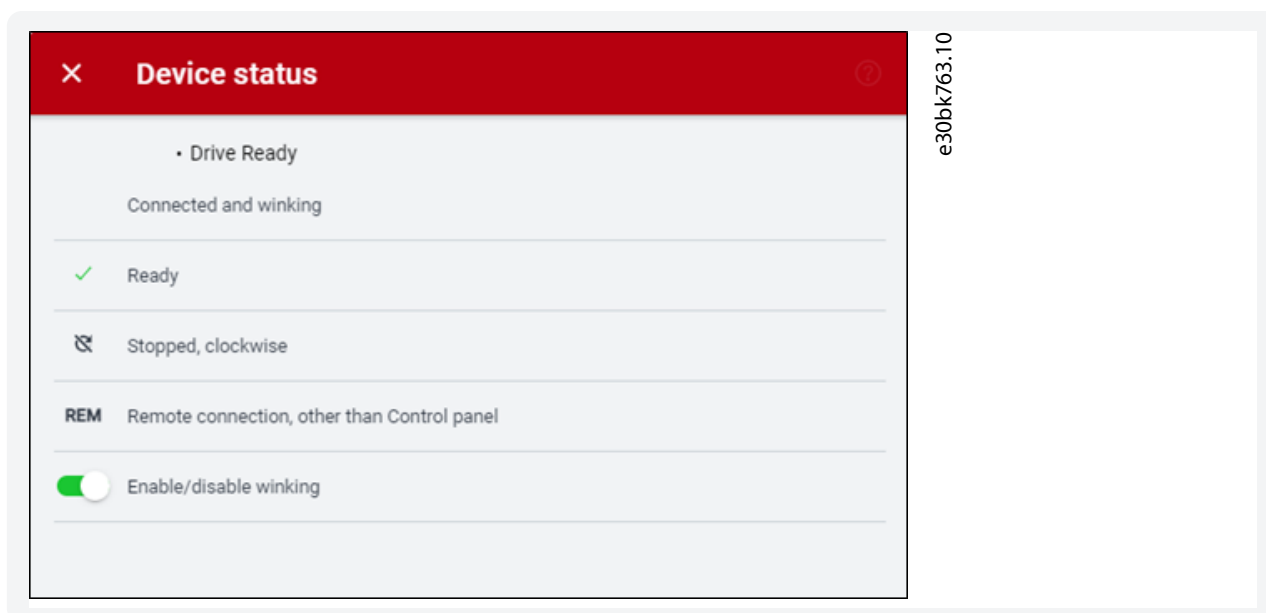

See [6.5 Fieldbus Indicator LEDs](#) for more information on interpreting the LED signals and where the LEDs are located.

6.5 Fieldbus Indicator LEDs

The fieldbus indicator LEDs are in the top right corner of the control panel and the bottom part of the front-facing side of the modular control unit.

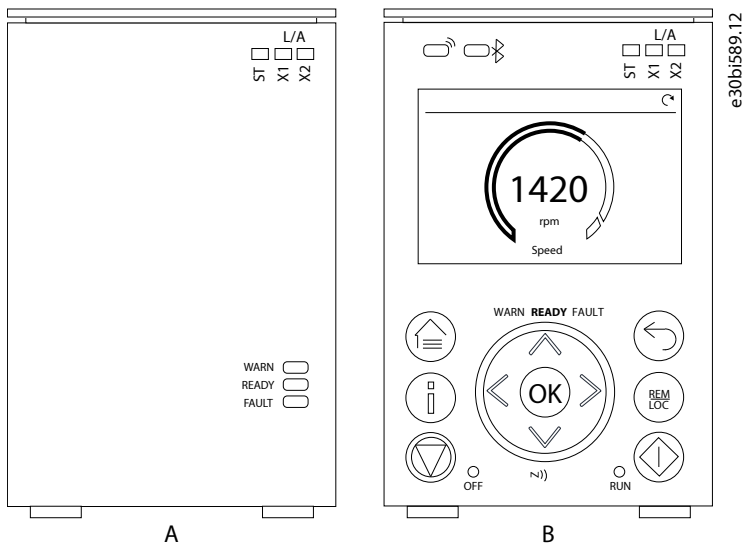

Figure 13: Fieldbus Indicator LEDs on Control Panel

A	Blind Panel	B	Control Panel 2.8
---	-------------	---	-------------------

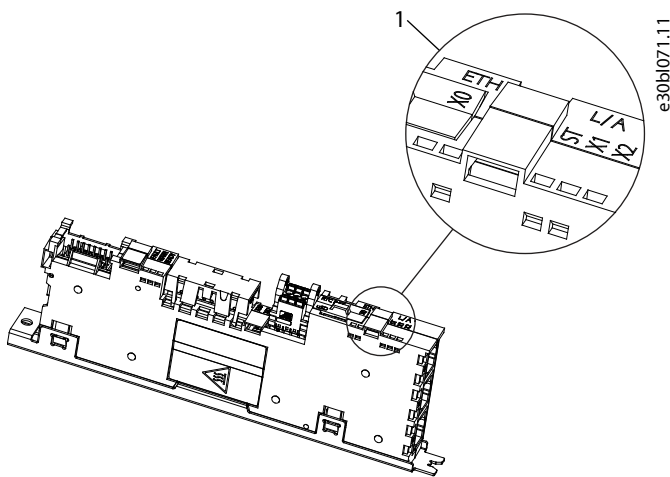

Figure 14: Fieldbus Indicator LEDs on Modular Control Board

1	Fieldbus indicator LEDs (ST, X1, and X2)
---	--

- The LED labeled ST shows the module status.
- The LED labeled X1 shows the network status on Ethernet port X1.
- The LED labeled X2 shows the network status on Ethernet port X2.

Table 25: Fieldbus Indicator LED Functions

LED label	Status	LED pattern	Description
ST	DCP blink	Flashing yellow	PROFINET discovery protocol active, 3 s flashing.
	Not configured	Off	PROFINET not configured.
	I/O connection faulted	Steady red	A PROFINET I/O connection has faulted.
	Configuration mismatch	Flashing red	PROFINET configuration mismatch.
	Configured/No I/O connection	Flashing green	Device is configured from PLC master but no I/O connection has been established.
	All I/O connections OK	Solid green	PROFINET I/O connection to device established.
X1/X2	DCP blink	Flashing yellow	PROFINET discovery protocol active, 3 s flashing.
	Link down	Off	–
	Invalid configuration/Duplicated IP address	Solid red	IP configuration error
	Link up	Solid green	The Ethernet link is active.



Danfoss Drives Oy
Runsorintie 7
FIN-65380 Vaasa
drives.danfoss.com

Any information, including, but not limited to information on selection of product, its application or use, product design, weight, dimensions, capacity or any other technical data in product manuals, catalog descriptions, advertisements, etc. and whether made available in writing, orally, electronically, online or via download, shall be considered informative, and is only binding if and to the extent, explicit reference is made in a quotation or order confirmation. Danfoss cannot accept any responsibility for possible errors in catalogs, brochures, videos and other material. Danfoss reserves the right to alter its products without notice. This also applies to products ordered but not delivered provided that such alterations can be made without changes to form, fit or function of the product. All trademarks in this material are property of Danfoss A/S or Danfoss group companies. Danfoss and the Danfoss logo are trademarks of Danfoss A/S. All rights reserved.

172K4282B
AQ481922043454en-010201
Danfoss Drives Oy © 2026.06



1 7 2 K 4 2 8 2 B