



iC7 Series Liquid-cooled System Modules

Active Front-End, Grid Converter, Inverter, Brake Chopper Unit, and DC/DC Converter Modules



Contents

1 Introduction

1.1 Purpose of this Design Guide	13
1.2 Additional Resources	13
1.3 Planning and Design Support Materials	13
1.3.1 Overview	13
1.3.2 Locating Support Information	14
1.4 Version History	14
1.5 Abbreviations	14
1.6 Recommended Disposal	15

2 Safety

2.1 Safety	17
2.2 Safety Symbols	17
2.3 General Safety Considerations	17
2.4 Target Group and Necessary Qualifications	18

3 Danfoss iC7 Series

3.1 Overview of iC7 Series	19
----------------------------	----

4 Overview of the iC7 Series Liquid-cooled System Modules

4.1 System Modules	20
4.2 Control System of the System Modules	24
4.3 Contents of the Delivery	24
4.4 Description of the Frame Designation	24
4.5 Weights	25
4.6 Common DC-bus Drive System	27
4.7 Description of the Model Code	27
4.8 Options	29
4.9 Labels on the Products	31
4.9.1 Labels on the System Module	31
4.9.2 Labels on other Components	32
4.9.3 Product Label	34
4.10 Lifting the Product	35

4.10.1 Lifting the System Modules	35
4.10.2 Lifting the System Modules with Integration Unit	36
4.10.3 Lifting the Filters	37

5 Mechanical Installation Considerations

5.1 Storing the System Module	38
5.2 Requirements for the Cabinet	38
5.3 Mechanical Installation	38
5.3.1 Installation Requirements	38
5.3.2 Installation Directions	38
5.3.3 Installing System Modules	38
5.3.3.1 Installing System Modules into a Cabinet Vertically	38
5.3.3.2 Installing System Modules into a Cabinet Horizontally	40
5.3.3.3 Installing System Modules into a Cabinet on their Backsides	40
5.3.4 Installing System Modules with Integration Units	41
5.3.4.1 Installing System Modules with Integration Units into a Cabinet Vertically	41
5.3.4.2 Installing System Modules with Integration Units into a Cabinet Horizontally	43
5.3.4.3 Installing System Modules with Integration Units into a Cabinet on their Backsides	45
5.3.5 Installing Filters	46
5.3.5.1 Installing L Filter into a Cabinet, 400 A and 1000 A	46
5.3.5.2 Installing L Filter into a Cabinet, 1640 A and 2300 A	48
5.3.5.3 Installing the SISO Filter Feedback Capacitors into a Cabinet	49

6 Cooling Requirements

6.1 Safety in Liquid-cooling	50
6.2 General Information on Cooling	50
6.3 Coolant	51
6.3.1 Quality Requirements for Cooling Water	51
6.3.2 Purified Water as Coolant	52
6.3.3 Antifreeze Mix as Coolant	52
6.3.4 Requirements for the Coolant over the Entire Service Life	52
6.3.5 Temperature of the Coolant	53
6.4 Cooling System	53
6.4.1 Cooling Connection of the L Filter	53
6.4.2 Materials	54
6.4.3 Heat Exchanger	54

6.4.4	Flow Rate of the Coolant	54
6.4.4.1	Flow Rates in Parallel Power Units	56
6.4.5	Volume of the Pipe	58
6.4.6	Pressure Drop	59
6.4.6.1	Pressure Drop and Correction Factors	59
6.4.6.2	Pressure Drop of IM10L, IM12L, AM10L, AM12L, DM10L, DM12L, BM 10L and BM12L	60
6.4.6.3	Pressure Drop of AR10L, IR10L, and Filters	61
6.4.6.4	Pressure Drop of AR12L, IR12L, and Filters	65
6.4.6.5	Pressure Drop of the Grid-side L Filter	70
6.4.6.6	Pressure Drop of DR10L, DR12L, and Filters	73
6.4.7	Cooling Circuit Connectors	74
6.4.7.1	Pipe Ferrules	75
6.4.7.2	Insertion of Pipes into Cooling Circuit Connectors	75
6.4.7.3	Inlet and Outlet Connectors of System Modules	75
6.4.7.4	Inlet and Outlet Connectors of System Modules with Integration Units	76
6.4.7.5	Inlet and Outlet Connectors of System Modules with Short Integration Units	77
6.4.7.6	Inlet and Outlet Connectors of the L Filter	78
6.4.7.7	Inlet and Outlet Connectors of the Reactor	78
6.4.8	Cooling Circuit Pipes	79
6.4.8.1	Bending Pipes in the Air	79
6.4.8.2	Bending Pipes with a Bending Jig	80
6.4.9	Filling the Cooling System	81
6.5	Condensation	84
6.6	Air Cooling Requirements	85
7	Electrical Installation	
7.1	Fuses of the Drive System	87
7.2	Guidelines for DC Connections of System Modules	87
7.3	Grounding Principles	90
7.4	Grounding the Products	90
7.5	Cable Requirements	92
7.5.1	Cable Requirements for Mains and Motor Cables	92
7.5.2	Requirements for DC-source Cables of DC/DC Converters	94
7.5.3	Cable Requirements for SISO Filter	94
7.6	Prerequisites for Cable Installation	95
7.7	Recommended Installation of Motor Cables	96

7.8 AFE and Grid Converter Field Cabling Installation	97
7.9 Installation of Cables with the Power Terminal Adapter	97
7.10 Installing the DC Fuses to the DC Terminals	98
7.11 Auxiliary Power Connection	100
7.11.1 Indicator Light Definitions	101
7.12 Installation in an IT System	101
7.12.1 Changing the EMC Protection Level, AR10L	103
7.12.2 Changing the EMC Protection Level, AR12L (+AEZ1/+AEZ3)	104
7.12.3 Changing the EMC Protection Level, LC Filter, OF7Z1, OF7SI2, OF7SI4, Size LC10L	105
7.12.4 Changing the EMC Protection Level, LC Filter, OF7Z1, OF7SI2, OF7SI4, Size LC12L	106
7.13 Filters	107
7.13.1 dU/dt Filter	107
7.13.2 Common-mode Filter	116
7.13.3 LC Filter	119
7.13.4 Sine-wave Filter	119
7.13.5 DC Filter	120
7.13.6 SISO Filter	120
7.14 AuxBus Communication	121
7.14.1 Usage of AuxBus	121
7.14.2 AuxBus Cable Requirements	124
7.14.3 AuxBus Grounding Principles	125
7.15 The Pre-charging Unit	125
7.16 Derating	126
7.16.1 Derating of Switching Frequency INU, Voltage Class A5	126
7.16.2 Derating of Switching Frequency INU, Voltage Class B5 and 07	127
7.16.3 Derating of Coolant Temperature, Voltage Class A5	127
7.16.4 Derating of Coolant Temperature, Voltage Class B5 and 07	128
7.16.5 Derating of DC-bus Voltage, Voltage Class A5	128
7.16.6 Derating of DC-bus Voltage	129
7.16.7 Derating of Output Frequency, Voltage Class A5, B5, and 07	129
7.16.8 Derating of Switching Frequency DC/DC, Voltage Class B5 and 07	130
7.16.9 Derating of Voltage Imbalance, AFE/GC	130
7.17 Modulator Types	131

8 Control Unit

8.1 Modular Control Unit	132
8.2 Control Board	133
8.3 Definitions of the Indicator Lights on the Control Board	134
8.4 Control Board Connections	135
8.5 Star Coupler Board	136
8.6 Definitions of the Indicator Lights on the Star Coupler Board	140
8.7 Star Coupler Board Connections	140
8.8 I/O and Relay Option (OC7C1) Connections	141
8.9 I/O and Relay Option Interface	143
8.9.1 Analog Inputs	143
8.9.2 Analog Outputs	144
8.9.3 Digital Inputs	145
8.9.4 Digital Outputs	145
8.9.5 Relay Outputs	145
8.9.6 Analog Reference Voltage Output	146
8.9.7 24 V DC Voltage Output	146
8.9.8 Thermistor Input	147
8.10 Assembling the Control Unit Mounting Plates	147
8.11 Attaching the Control Unit Mounting Plates	147
8.12 Installing the Control Unit	148
8.13 Installing Boards to the Modular Control Unit	148
8.14 Connecting the Fieldbus Cable and the Fiber Cables	149
8.15 Installing the Control Cables into the Control Terminals	150
8.16 Connecting the Control Panel	151
8.17 Fiber Cable Requirements	151

9 Maintenance

9.1 Preventive Maintenance Recommendations	152
9.2 Maintenance Log for Cooling System	154
9.3 Using the Product Modified Label	155
9.4 Replacing the RTC Battery	155
9.5 Removing the System Module from the Integration Unit	156
9.6 Installing the System Module in the Integration Unit	160

9.7 Draining the System Modules	161
9.7.1 Draining the System Modules, System Modules with Integration Units, and Filters	161
9.7.2 Draining the Power Units for xR10L and xR12L	163
10 Specifications	
10.1 Tightening Torques	165
10.2 Dimensions	166
10.2.1 Dimensions of the Inverter Module, IM10L, AFE/GC Module, AM10L, DC/DC Converter Module, DM10L, and, BCU, BR10L	166
10.2.2 Dimensions of the System Modules with Short Integration Units (+AE01) IR10/AR10L/DR10L/BR10L	167
10.2.3 Dimensions of the Inverter Module, IR10L	168
10.2.4 Dimensions of the Active Front-end Module/Grid Converter, AR10L	169
10.2.5 Dimensions of the DC/DC Converter, DR10L	170
10.2.6 Dimensions of the Inverter Module, IM12L, AFE/GC Module, AM12L, DC/DC Converter Module, DM12L and, BCU, BR12L	171
10.2.7 Dimensions of the System Modules with Short Integration Units (+AE01) IR12/AR12L/DR12L/BR12L	172
10.2.8 Dimensions of the Inverter Module, IR12L	173
10.2.9 Dimensions of Active Front-end Module/Grid Converter, AR12L	174
10.2.10 Dimensions of the DC/DC Converter, DR12L	175
10.2.11 Dimensions of the LC filter for AM10L	176
10.2.12 Dimensions of the LC Filter for AM12L	177
10.2.13 Dimensions of the L Filter, 400 A	178
10.2.14 Dimensions of the L Filter, 1000 A	179
10.2.15 Dimensions of the L Filter, 1640 A	180
10.2.16 Dimensions of the L Filter, 2300 A	181
10.2.17 Dimensions of the Reactor, 450 A	182
10.2.18 Dimensions of the Reactor, 900 A	183
10.2.19 Dimensions of the Reactor, 1750 A	184
10.2.20 Dimensions of the Feedback Capacitors	185
10.2.21 Dimensions of the Fuse Holder for Feedback DC Fuses	186
10.2.22 Dimensions of the dU/dt Filter and the Common-mode Filter for IM10L	187
10.2.23 Dimensions of the dU/dt Filter for IM12L	188
10.2.24 Dimensions of the DC Filter for DM10L	189
10.2.25 Dimensions of the DC Filter for DM12L	190
10.2.26 Dimensions of the Sine-wave Filter	191
10.2.27 Dimensions of the Control Unit	192

10.2.28	Dimensions of the Control Unit Mounting Plate	193
10.2.29	Dimensions of the Option Connector	194
10.2.30	Dimensions of the Control Board	195
10.2.31	Dimensions of the I/O and Relay Option	196
10.2.32	Dimensions of an Option Board	197
10.2.33	Dimensions of the 4-port Star Coupler Board	198
10.2.34	Dimensions of the 8-port Star Coupler Board	199
10.2.35	Dimensions of the 16-port Star Coupler Board	200
10.2.36	Dimensions of the Pre-charging Unit, IEC	201
10.2.37	Dimensions of the Pre-charging Unit, UL	202
10.2.38	Dimensions of the DC Fuses, xx10L	202
10.2.39	Dimensions of the DC Fuses, xx12L	203
10.2.40	Dimensions for the Control Panel Flush Mounting Kit	204
10.2.41	Dimensions for the Control Panel Surface Mounting Kit	205
10.3	Wiring Diagrams	206
10.3.1	Wiring Diagram, AFE/GC, AR10L and INU +AEZ1, IR10L	206
10.3.2	Wiring Diagram, AFE/GC, AR12L and INU +AEZ1, IR12L	206
10.3.3	Extended Wiring Diagram for Energy Storage Applications, GC, AR12L, Voltage Class G7	207
10.3.4	Wiring Diagram, INU, IR10L	208
10.3.5	Wiring Diagram, INU, IR12L	209
10.3.6	Wiring Diagram, INU IR12L with Sine-wave Filter	209
10.3.7	Wiring Diagram, DC/DC Converter, DR10L	210
10.3.8	Wiring Diagram, DC/DC Converter, DR12L	210
10.3.9	Wiring Diagram, BCU, BM10L/BR10L	211
10.3.10	Wiring Diagram, BCU, BM12L/BR12L	211
10.3.11	Wiring Diagram, SISO Filters, +AEZ2/+AEZ4, +AES2	212
10.3.12	Pre-charging Circuit, AR10L	216
10.3.13	Pre-charging Circuit, AR12L	217
10.3.14	Pre-charging Control Circuit Diagrams	218
10.3.15	The Pre-charging Function	219
10.3.16	Wiring Diagrams of the +24 V Supply for the Control Unit	220
10.3.17	Wiring Diagram for Connecting Surge Protection Device Monitoring and Circuit Breaker Control to I/O and Relay Option, Grid Converter, Voltage Class G7	222
10.4	Cable Sizes	222
10.4.1	General Information on the Cable Tables	222
10.4.2	Field Cable Sizes for AFE and GC Modules, 380–500 V AC	223

10.4.3	Field Cable Sizes for AFE and GC Modules, 525–690 V AC	224
10.4.4	Field Cable Sizes for GC Modules, 380–690 V AC	226
10.4.5	Bolt Sizes for the Internal AC Busbars/Cables for AFE and GC Modules, 380–690 V AC	226
10.4.6	Cable Sizes for the Internal AC Cables for AFE and GC Modules, 380–690 V AC	226
10.4.7	Internal AC Busbar Sizing within the Enclosure of the AFE/GC Modules	227
10.4.8	Field Cable Sizes for INU Module, 380–500 V AC	228
10.4.9	Field Cable Sizes for INU Module, 525–690 V AC	229
10.4.10	Source Cable Sizes for DC/DC Converter Modules, 640–1100 V DC	230
10.4.11	Marine Cable Sizes for AFE or GC Modules 380–500 V AC	231
10.4.12	Marine Cable Sizes for AFE or GC Modules 525–690 V AC	232
10.4.13	Marine Cable Sizes for INU Modules 380–500 V AC	234
10.4.14	Marine Cable Sizes for INU Modules 525–690 V AC	234
10.4.14.1	Cable Sizes for DC-filter Capacitors	236
10.4.15	UL-Rated Cables	236
10.4.15.1	Mains Cable Sizes for AFE or GC Modules, UL 480 V	236
10.4.15.2	Mains Cable Sizes for AFE or GC Modules, UL 600 V	237
10.4.15.3	Motor Cable Sizes for Inverter Modules, UL 460 V	238
10.4.15.4	Motor Cable Sizes for Inverter Modules, UL 575 V	239
10.4.16	Brake Cable Sizes for BCU, 525–690 V AC	241
10.4.17	Internal DC Cable Sizes for SISO Filters	241
10.5	Fuses	242
10.5.1	General Information on the Fuse Tables	242
10.5.2	AC Fuses for AFE or GC 380–500 V AC, IP00/Open Type	243
10.5.3	AC Fuses for AFE or GC 525–690 V AC, IP00/Open Type	245
10.5.4	DC Fuses for AFE or GC 450–830 V DC, IP00/Open Type	248
10.5.5	DC Fuses for AFE or GC 640–1100 V DC, IP00/Open Type	250
10.5.6	AC Fuses for GC 380–690 V AC, Voltage Class G7, IP00/Open Type	252
10.5.7	DC Fuses for GC 380–690 V AC (500–1500 V DC), Voltage Class G7, IP00/Open Type	253
10.5.8	DC Fuses for INU 450–830 V DC, IP00/Open Type	254
10.5.9	DC Fuses for INU 640–1100 V DC, IP00/Open Type	255
10.5.10	AC Fuses for INU, IP00/Open Type in Generator Use	258
10.5.11	DC-bus Fuses for DC/DC Converter, IP00/Open Type	264
10.5.12	Source DC+ Fuses for DC/DC Converter, IP00/Open Type	265
10.5.13	Source DC- Fuses for DC/DC Converter, IP00/Open Type	266
10.5.14	DC Fuses for BCU, Voltage Class B5 and 07, IP00/Open Type	266
10.5.15	AC Fuses and Circuit Breakers for L Filter, Voltage Class A5	267

10.5.16 AC Fuses and Circuit Breakers for L Filter, Voltage Class B5 and 07	269
10.5.17 AC Fuses and Circuit Breakers for L Filter, Voltage Class G7	272
10.5.18 DC Fuses for SISO Filters 640–1100 V DC, IP00/Open Type	273
10.6 Current Ratings	274
10.6.1 General Information on the Current Rating Tables	274
10.6.2 Current Ratings for AFE 380–440 V AC (425–650 V DC)	275
10.6.3 Current Ratings for AFE 440–500 V AC (425–830 V DC)	276
10.6.4 Current Ratings for AFE 380–500 V AC (425–830 V DC)	277
10.6.5 Current Ratings for AFE 525–690 V AC (640–1100 V DC)	278
10.6.6 Current Ratings for GC 380–440 V AC (425–650 V DC)	279
10.6.7 Current Ratings for GC 440–500 V AC (650–830 V DC)	280
10.6.8 Current Ratings for GC 380–500 V AC (425–830 V DC)	281
10.6.9 Current Ratings for GC 525–690 V AC (640–1100 V DC)	282
10.6.10 Current Ratings for GC 380–690 V AC (500–1500 V DC)	283
10.6.11 Current Ratings for INU 380–440 V AC (425–650 V DC)	284
10.6.12 Current Ratings for INU 440–500 V AC (650–830 V DC)	285
10.6.13 Current Ratings for INU 380–500 V AC (425–830 V DC)	286
10.6.14 Current Ratings for INU 525–690 V AC (640–1100 V DC)	287
10.6.15 Current Ratings for DC/DC Converter 425–830 V DC	288
10.6.16 Current Ratings for DC/DC Converter 640–1100 V DC	289
10.6.17 Current Ratings for BCU 380–500 V AC (425–830 V DC), Voltage Class A5	290
10.6.18 Current Ratings for BCU 380–500 V AC (425–830 V DC), Voltage Class B5	290
10.6.19 Current Ratings for BCU 525–690 V AC (640–1100 V DC), Voltage Class 07	291
10.6.20 Current Ratings for the INU with Sine-wave Filter (+AES1) (+AES2) and LC-filter (+AEZ1), 380–500 V AC	292
10.6.21 Current Ratings for the INU with Sine-wave Filter (+AES1) (+AES2) and LC-filter (+AEZ), 600–690 V AC	293
10.7 Power Losses	295
10.7.1 List of Power Loss Information	295
10.7.2 Power Losses of AFE and GC Modules 400 V AC, 594 V DC (425–830 V DC)	295
10.7.3 Power Losses of AFE and GC Modules 400 V AC, 594 V DC (425–830 V DC) with options +AEZ1 and +AEZ3	297
10.7.4 Power Losses of AFE and GC Modules 500 V AC, 742 V DC (425–830 V DC)	298
10.7.5 Power Losses of AFE and GC Modules 500 V AC, 742 V DC (425–830 V DC) with options +AEZ1 and +AEZ3	299
10.7.6 Power Losses of AFE and GC Modules, Voltage Class 07	301
10.7.7 Power Losses of AFE and GC Modules, Voltage Class 07, with +AEZ1 and +AEZ3	302
10.7.8 Power Losses of AFE and GC Modules, Voltage Class B5	303
10.7.9 Power Losses of AFE and GC Modules, Voltage Class B5, with +AEZ1 and +AEZ3	304

10.7.10 Power Losses of GC Modules, Voltage Class G7, with +AEZ1 and +AEZ3	305
10.7.11 Power Losses of GC Modules, Voltage Class G7, with +AEZ1	306
10.7.12 Power Losses of INU Modules with +AEU1, Voltage Class 07, Motor Cable Maximum Length 150 m (492 ft)	307
10.7.13 Power Losses of INU Modules with +AEU1, Voltage Class 07, Motor Cable Maximum Length 50 m (164 ft)	308
10.7.14 Power Losses of INU modules 400 V AC (594 V DC), Voltage class A5, Modulator Type 1	310
10.7.15 Power Losses of INU modules 400 V AC (594 V DC), Voltage class A5, Modulator Type 2	312
10.7.16 Power Losses of INU modules 500 V AC (460–800 V DC), Voltage class A5, Modulator Type 1	315
10.7.17 Power Losses of INU modules 500 V AC (460–800 V DC), Voltage class A5, Modulator Type 2	317
10.7.18 Power Losses of INU Modules without Options, Voltage Class 07, Modulator Type 1 – SVPWM	320
10.7.19 Power Losses of INU Modules without Options, Voltage Class 07, Modulator Type 6 – Optimized	321
10.7.20 Power Losses of INU Modules with +AEU1, Voltage Class B5, Motor Cable Maximum Length 150 m (492 ft)	323
10.7.21 Power Losses of INU Modules with +AEU1, Voltage Class B5, Motor Cable Maximum Length 50 m (164 ft)	324
10.7.22 Power Losses of INU Modules without Options, Voltage Class B5, Modulator Type 1 – SVPWM	325
10.7.23 Power Losses of INU Modules without Options, Voltage Class B5, Modulator Type 6 – Optimized	326
10.7.24 Power Losses of INU Modules with +AES1, Voltage Class 07	327
10.7.25 Power Losses of INU Modules with +AES1, Voltage Class B5	328
10.7.26 Power Losses of DC/DC Converter Modules, Voltage Class 07	329
10.7.27 Power Losses of DC/DC Converter Modules, Voltage Class B5	330
10.7.28 Power Losses of BCU Modules, Voltage Class B5, 500 V AC, 800 V DC	331
10.7.29 Power Losses of BCU Modules, Voltage Class 07, 690 V AC, 1100 V DC	332
10.8 Technical Data	332

1 Introduction

1.1 Purpose of this Design Guide

This design guide is intended for qualified personnel, such as:

- Project and systems engineers.
- Design consultants.
- Application and product specialists.

The design guide provides technical information to understand the capabilities of the iC7 drives for integration into motor control and monitoring systems. Its purpose is to provide design considerations and planning data for integration of the drive into a system. It caters for selection of drives and options for a diversity of applications and installations. Reviewing the detailed product information in the design stage enables developing a well-conceived system with optimal functionality and efficiency.

This guide is targeted at a worldwide audience. Therefore, wherever occurring, both SI and imperial units are shown.

1.2 Additional Resources

Additional resources are available to help understand the features, and safely install and operate the iC7 products:

- Safety guides, which provide important safety information related to installing iC7 drives.
- Installation guides, which cover the mechanical and electrical installation of drives, or functional extension options.
- Operating guides, which include instructions for control options and other components for the drive.
- Application guides, which provide instructions on setting up the drive for a specific end use. Application guides for application software packages also provide an overview of the parameters and value ranges for operating the drives, configuration examples with recommended parameter settings, and troubleshooting steps.
- *Facts Worth Knowing about AC Drives*, available for download on www.danfoss.com.
- Other supplemental publications, drawings, and guides are available at www.danfoss.com.

Latest versions of Danfoss product guides are available for download at www.danfoss.com/en/service-and-support/documentation/.

1.3 Planning and Design Support Materials

1.3.1 Overview

Danfoss provides access to comprehensive product information that supports throughout the product lifecycle.

All iC7 series design guides, installation guides, safety guides, operating guides, and application guides are available for download at www.danfoss.com. It is also possible to order printed guides.

For each iC7 drive or power converter, 2D and 3D drawings, and wiring diagrams are available in standard file formats. EPLAN files with macros, technical data, and 3D models are also provided to support in the system design.

EPLAN files with macros are available for download from the EPLAN Data Portal at www.eplandataportal.com. The configurator in EPLAN Electric P8 provides access to Danfoss drive data, optimizes system design by automating the EDZ file generation, and ensures precise specifications.

Configuration files for drives or power converters are also available. MyDrive® Suite provides tools that support the entire lifecycle of the product, from system design to service. MyDrive® Suite is available at <https://suite.mydrive.danfoss.com/>.

The Danfoss product configurator (available at <https://store.danfoss.com>) helps in the product selection, and when the process has been completed, the tool provides a list of relevant documentation and accessories.

Detailed product information can also be accessed by reading the 2D code on the product label.

1.3.2 Locating Support Information

Additional information is available on the company website.

1. Go to www.danfoss.com.
2. Select *Products*.
3. Select *Drives*.
4. Select the product series, for example *Low-voltage drives* or *System modules*.
5. Select the product series (for example, iC7).

 The browser opens the product page, which provides links to documents, drawings, and software of the product.

1.4 Version History

This guide is regularly reviewed and updated. All suggestions for improvement are welcome.

The original language of this guide is English.

Table 1: Version History

Version	Remarks
172K2848A	Design Guide created based on the previous Operating Guide 139Z5997C.
172K2848B	Changes throughout the guide. Sine-wave filter data added.
172K2848C	A new L filter variant 2300 A added. New AC fuse data added. Small changes throughout the guide.
172K2848D	Current rating data for L filter variant 2300 A added. Small changes throughout the guide.
172K2848E	Information on 2 new voltage classes added, G7 and A5.
172K2848F	Small changes in SISO filter data.

1.5 Abbreviations

Table 2: Abbreviations, Acronyms, and Symbols

Term	Definition
AC	Alternating current
AFE	Active front-end
AI	Analog input
AO	Analog output
BCU	Brake chopper
DC	Direct current
DI	Digital input
DO	Digital output
EMC	Electromagnetic compatibility
EN	European standards
ESD	Electrostatic discharge

Table 2: Abbreviations, Acronyms, and Symbols - (continued)

Term	Definition
GC	Grid converter
GND	Ground
I	Current
IEC	International Electrotechnical Commission
INU	Inverter
I/O	Input/output
IP	Ingress protection
IT	Isolé terre
LC	Inductor-capacitor
LED	Light-emitting diode
L/R	Time constant for a DC circuit
NC	Normally closed
NEMA	National Electrical Manufacturers Association
NFE	Non-regenerative front end
NO	Normally open
PCB	Printed circuit board
PE	Protective earth
RMS	Root mean square
RTC	Real-time clock
SPD	Surge-protection device
STO	Safe torque off
U	Voltage

1.6 Recommended Disposal

When the product reaches the end of its service life, its primary components can be recycled.

Before the materials can be removed, the product must be disassembled. Product parts and materials can be dismantled and separated. Generally, all metals, such as steel, aluminum, copper and its alloys, and precious metals can be recycled as material. Plastics, rubber, and cardboard can be used in energy recovery. Printed circuit boards and large electrolytic capacitors with a diameter of over 2.5 cm (1 in) need further treatment according to IEC 62635 guidelines. To ease recycling, plastic parts are marked with an appropriate identification code.

Contact the local Danfoss office for further information on environmental aspects and recycling instructions for professional recyclers. End-of-life treatment must follow international and local regulations.

All products are designed and manufactured in accordance with Danfoss company guidelines on prohibited and restricted substances. A list of these substances is available at www.danfoss.com.



This symbol on the product indicates that it must not be disposed of as household waste. Do not dispose of equipment containing electrical components together with domestic waste.

It must be handed over to the applicable take-back scheme for the recycling of electrical and electronic equipment.

- Dispose of the product through channels provided for this purpose.
 - Comply with all local and currently applicable laws and regulations.
-

2 Safety

2.1 Safety

When designing variable frequency drives, some residual dangers cannot be avoided. One example is the discharge time, which must be observed to avoid potential death or serious injury. The discharge time is shown on the danger label on the drive.

For further information on safety precautions related to the installation, operation, or maintenance of products, refer to the product-specific installation, safety, and operating guides.

2.2 Safety Symbols

The following symbols are used in Danfoss documentation and products.

DANGER
Indicates a hazardous situation which, if not avoided, will result in death or serious injury.

WARNING
Indicates a hazardous situation which, if not avoided, could result in death or serious injury.

CAUTION
Indicates a hazardous situation which, if not avoided, could result in minor or moderate injury.

NOTICE
Indicates information considered important, but not hazard-related (for example, messages relating to property damage).

	ISO warning symbol for general warnings
	ISO warning symbol for hot surfaces and burn hazard
	ISO warning symbol for high voltage and electric shock
	Symbol for indicating the required discharge time of the capacitors in the product.
	ISO action symbol for referring to the instructions

2.3 General Safety Considerations

WARNING	
	<p>LACK OF SAFETY AWARENESS</p> <p>This guide provides important information on preventing injury and damage to the equipment or the system. Ignoring this information can lead to death, serious injury, or severe damage to the equipment.</p> <ul style="list-style-type: none"> • Make sure to fully understand the dangers and safety measures present in the application.

DANGER

DISCHARGE TIME

The drive contains capacitors, which can remain charged even when the drive is not powered. High voltage can be present even when the warning indicator lights are off.

Failure to wait the specified time after power has been removed before performing service or repair work could result in death or serious injury.

- Stop the drive.
- Disconnect all input and output power sources of the drive (for example permanent magnet type motors, batteries, or DC-link connections to other drives).
- Wait for the capacitors to discharge fully before performing any service on the equipment. The discharge time is 5 minutes. If the device is broken or fuses have tripped, the discharge time is longer.
- Use a measuring device to make sure that there is no voltage, before opening the drive or performing any work on the cables.

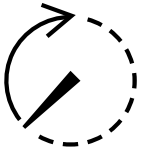
DANGER

ELECTRIC SHOCK

The drive contains hazardous voltage when a power source is connected to the AC or DC terminals. Failure to disconnect all power sources can result in death or serious injury.

- Before performing any electrical work on the drive, disconnect, lock out, and tag out all power sources to the drive.
- There is more than 1 live circuit. See the relevant wiring diagrams in the product guide and the diagrams delivered with the product.

WARNING
UNINTENDED START

When the drive is connected to a power source, the system may start at any time, causing risk of death, serious injury, and equipment or property damage.

- Stop the drive and motor before configuring parameters.
- Make sure that the drive cannot be started by an external switch, a fieldbus command, an input reference signal from the control panel, or after a cleared fault condition.
- Disconnect the drive from the power source whenever safety considerations make it necessary to avoid unintended start.
- Check that the drive, motor, and any driven equipment are in operational readiness.

2.4 Target Group and Necessary Qualifications

Correct and reliable transport, storage, installation, operation, and maintenance are required for the trouble-free and safe operation of the products. Only qualified personnel are allowed to perform all related activities for these tasks. Qualified personnel are defined as properly trained staff, who are familiar with and authorized to install, commission, and maintain the equipment/systems and circuits in accordance with pertinent laws and regulations. Also, the qualified personnel must be familiar with the instructions and safety measures described in this guide and other relevant guides. Non-qualified electricians are not allowed to perform any electrical installation or troubleshooting activities.

Specialized training is required for repair. Only Danfoss authorized, qualified personnel are allowed to repair this equipment.

3 Danfoss iC7 Series

3.1 Overview of iC7 Series

The Danfoss iC7 series comprises 3 products that combine hardware and software:

- iC7-Automation
- iC7-Hybrid
- iC7-Marine

The series consists of 3 hardware variants:

- System modules
- Enclosed drives
- Frequency converters

Additional application software can be purchased and some application software are only available for a specific hardware variant and product.

The following application software packages are available for the system modules.

- iC7-Automation: Industry, AFE, Motion
- iC7-Marine: Propulsion & Machinery, AFE, BCU
- iC7-Hybrid: Grid Converter, DC/DC Converter, Generator Inverter

There are application guides available for all the application software packages.

4 Overview of the iC7 Series Liquid-cooled System Modules

4.1 System Modules

The liquid-cooled system modules have 2 product categories:

- The **system modules** are ideal for installation with low height clearance. Needed filters are installed externally.
- The **system modules with integration units** have integrated filters in a compact design, easy cabinet installation, and easy serviceability.

The protection rating of the power units is IP00, therefore the product must be installed in a cabinet or another enclosure after delivery.

The liquid-cooled system modules are available with different functions:

- Inverter
- Active front-end
- Grid converter
- Brake chopper unit
- DC/DC converter modules

The modules can be installed in parallel for higher power ratings.

The control unit of the system modules is installed separately. The control unit and the system modules are connected via fiber optics.

Inverter

The inverter (INU) module is intended for the regulation of motor speed in response to system feedback or to remote commands from external controllers. The inverter module requires a DC power source such as AFE or NFE to form a motor drive system. A drive system consists of the system modules, the motor, and equipment driven by the motor. The inverter module can be used for power generation applications, but it is also intended for system and motor status surveillance.

Active front-end

The active front-end (AFE) module is used to transfer power between the AC input and the intermediate DC bus. The main functionality of the AFE module is to maintain a stable DC-bus voltage reference and supply power for motor drives (INU). When there is load in the DC bus, the AFE module rectifies the alternating current and voltage and transfers power from the AC input to the DC bus. When there is excess energy in the DC bus, such as braking power of motors, the AFE module inverts the direct current and voltage, and transfers power from the DC bus to the AC input.

The AFE can boost the DC-bus voltage within the voltage window of the converter hardware. The advantage is that the DC voltage available for the inverters is not limited even under unideal grid conditions or if the grid voltage is lower in some regions.

The power quality of the AFE is superior to diode or thyristor rectifiers, since it does not draw reactive current from the grid and the harmonic distortion is low (<5%). The advantage is that the incoming transformer does not need to be oversized, transformer losses are lower, and the unit can meet the most stringent harmonic requirements. The DC-bus voltage is also much smoother and AFE can also produce reactive current to compensate for other low power factor equipment.

Grid converter

The grid converter (GC) module is a dedicated inverter for advanced grid-forming and bi-directional AC/DC power conversion. The GC can invert the DC voltage and rectify the AC voltage just like an AFE, but the power conversion control features are more advanced. The grid converter supports both open-loop and closed-loop AC voltage and frequency control.

The grid converter can create a microgrid and operate as the only power supply (island mode). The GC module can also be connected in parallel to other generating units with the frequency drooping function (μ Grid mode), and maintain the grid on its own if the other power generation is stopped. The grid converter can also inject high short-circuit current to ensure selectivity in the microgrid. Alternatively, the GC can be used to control active and reactive AC power or current, and DC power, current, or voltage.

Typical use cases for grid converters are AC-coupled energy storage, DC power supply for hydrogen electrolysis, micro grid-forming, shore power, shaft generator, and other marine energy management applications. The 1500 V DC (voltage class G7) grid converters can be used in applications that require grid code compliance.

DC/DC converter

The DC/DC converter is a bi-directional power converter, which enables the interconnection of 2 DC systems with different voltage levels. The DC/DC converter can boost the voltage from a lower voltage source to a higher DC-bus voltage, and step down the voltage of a DC bus to feed the source/load. The DC/DC converter can either control the DC-source voltage, DC-source current, or DC-bus voltage.

The DC/DC converter is often needed due to a mismatch between the voltage of the energy source and the DC voltage of the system. DC/DC converters can also be used as an adjustable DC voltage or current source and sink. A typical use case for the DC/DC converter is to connect an energy source to a DC grid or DC bus of a drive system for backup power, peak shaving, or fully electric applications.

Brake chopper unit

The brake chopper unit (BCU) is a unidirectional power converter for the supply of excessive energy from a common DC bus drive line-up. The energy is supplied to resistors where it is dissipated as heat. External resistors are required. The BCU improves the DC-link voltage controllability and enhances the motor drives performance in dynamic applications.

IM10L/AM10L/BM10L/DM10L

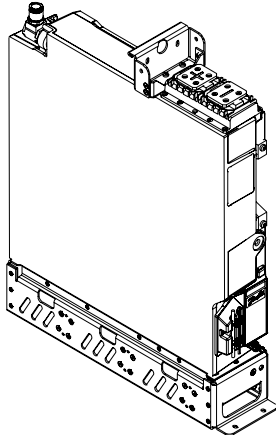

IM12L/AM12L/BM12L/DM12L

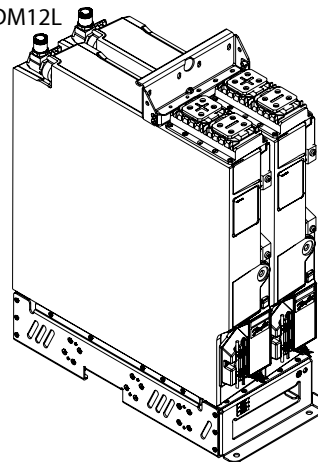

e30bh982.12

Figure 1: System Modules: IM10L/AM10L/BM10L/DM10L and IM12L/AM12L/BM12L/DM12L

IR10L/BR10L

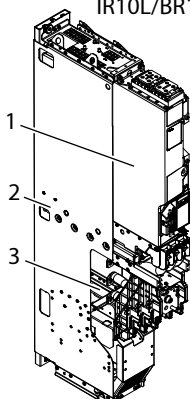

AR10L

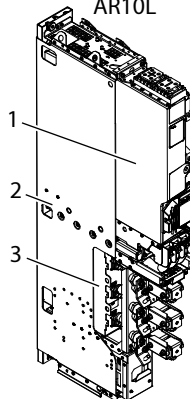

DR10L

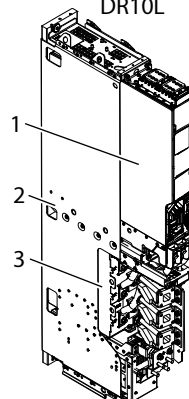

e30bn523.10

Figure 2: System Modules with Integration Units (+AE10): IR10L/BR10L/AR10L/DR10L

1	System module	2	Integration unit
3	Integrated filters (optional)		

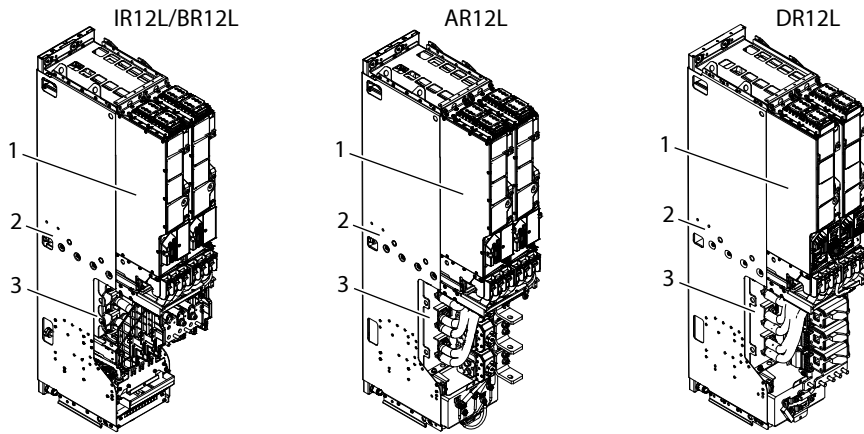

e-30bn524.10

Figure 3: System Modules with Integration Units (+AE10): IR12L/BR12L/AR12L/DR12L

- | | | | |
|---|-------------------------------|---|------------------|
| 1 | System module | 2 | Integration unit |
| 3 | Integrated filters (optional) | | |

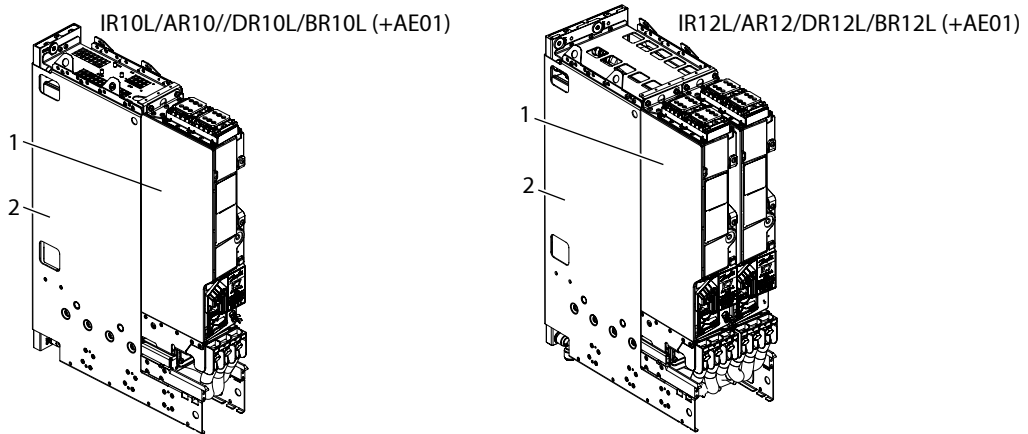

e-30bn538.10

Figure 4: System Modules with Short Integration Units (+AE01): IR10L/AR10L/DR10L/BR10L/IR12L/AR12L/DR12L/BR12L

- | | | | |
|---|---------------|---|------------------|
| 1 | System module | 2 | Integration unit |
|---|---------------|---|------------------|

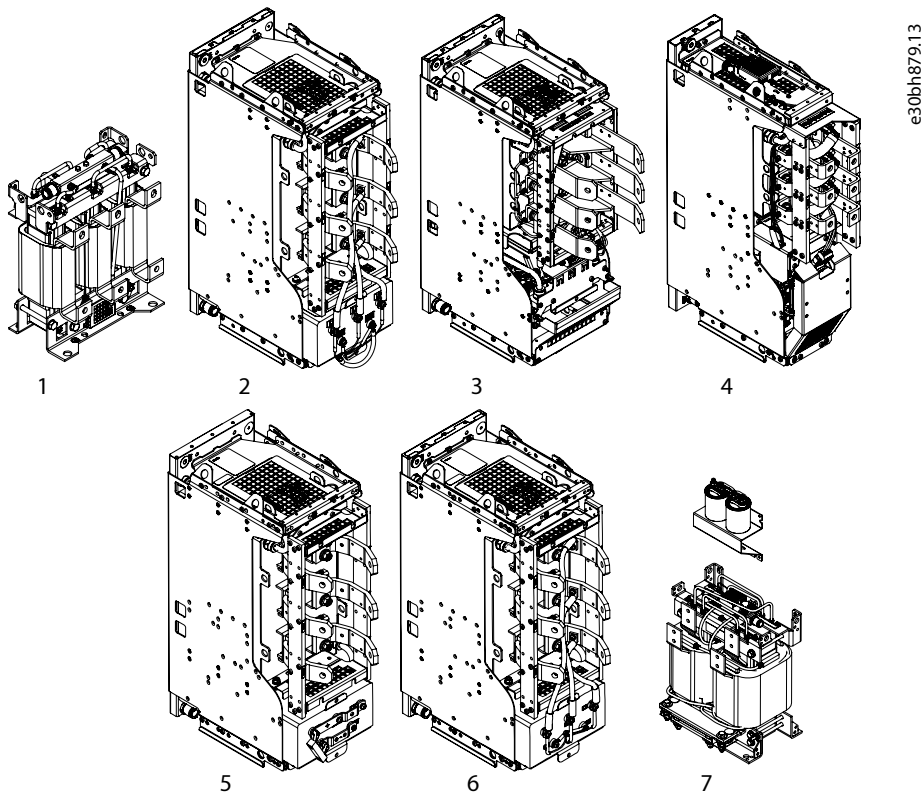

Figure 5: Liquid-cooled Filter Modules

1	Input L filter (part of LCL Filter)	2	LC Filter
3	dU/dt Filter	4	dU/dt and Common-mode Filter
5	DC Filter	6	Sine-wave filter
7	Reactor and feedback capacitors (part of SISO filter)		

4.2 Control System of the System Modules

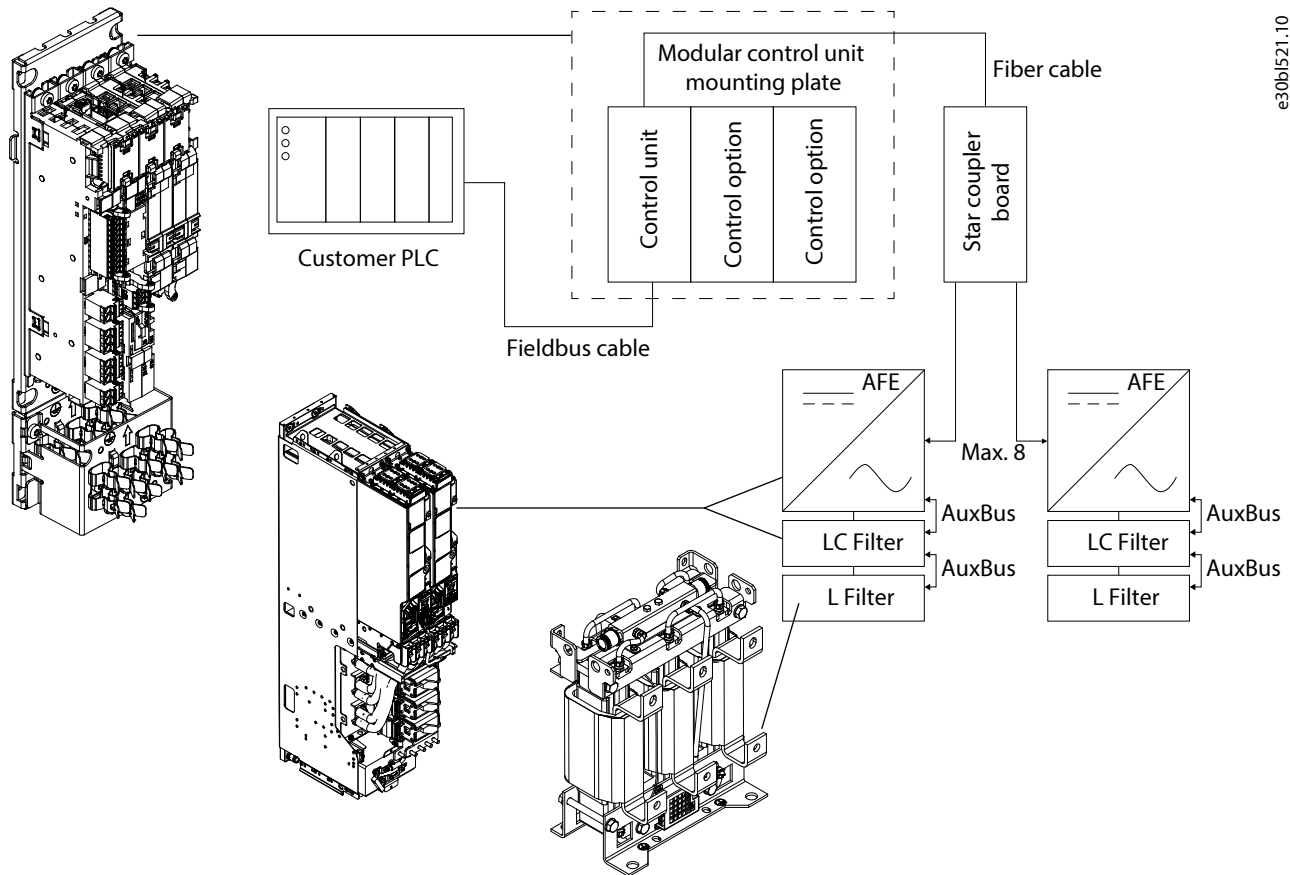

Figure 6: Example of a Control System of an AFE Module

4.3 Contents of the Delivery

The contents of the shipment of system modules

- Control unit with ordered control options
- Star coupler board for frames IM12L, AM12L, BM12L, BR12L, DM12L, IR12L, AR12L, and DR12L when the product consists of 2–16 power units
- Power unit
- Optical fiber cable
- 1 or 2 accessories bags for each power unit
- Other parts based on selected options
- Safety instructions

4.4 Description of the Frame Designation

A frame designation is used to refer to different types of iC7 Series system modules. The frame designation describes the function, mechanical variant, size, and cooling method of the system module.

The frame designation can have this format, for example:

IM10L

Table 3: Description of the Frame Designation

Code	Description
I	Function I = Inverter A = Active front-end/Grid converter D = DC/DC converter B= Brake
M	Mechanical variant M = System module R = System module with integration unit
10	Size 10 or 12
L	Cooling method L = Liquid-cooled

4.5 Weights

The weights in [Table 5](#) include the system module, the integration unit, and the filters.

Table 4: Description of the Frame Designation

Code	Description
I	Function: <ul style="list-style-type: none"> • I = Inverter • A = Active front-end/grid converter • D = DC/DC converter • B = Brake
M	Mechanical variant: <ul style="list-style-type: none"> • M = System module • R = System module with integration unit
10	Size: <ul style="list-style-type: none"> • 10 • 12
L	Cooling method: <ul style="list-style-type: none"> • L = Liquid-cooled

Table 5: Weights of the Liquid-cooled System Modules

Product	Weight [kg]	Weight [lb]
Inverter/brake module, AFE/GC module, or DC/DC converter module, IM10L, AM10L, DM10L, BM10L	41	90
Inverter/brake module + integration unit (no filter +AE10), IR10L, BR10L	73	161
Inverter module + integration unit (dU/dt Filter +AEU1), IR10L	106	234
Inverter module + integration unit (dU/dt+CM Filter +AEU2), IR10L	115	254
AFE/GC module + integration unit + LC Filter (+AEZ1), AR10L	138	304
AFE/GC module + integration unit + SISO-LC Filter (+AEZ2), AR10L	211	465
AFE/GC module + integration unit + LCL Filter (+AEZ3), AR10L	174	384

Table 5: Weights of the Liquid-cooled System Modules - (continued)

Product	Weight [kg]	Weight [lb]
DC/DC converter module + integration unit (DC Filter +AED1), DR10L	130	287
2 inverter/brake modules, 2 AFE modules, or 2 DC/DC converter modules, IM12L, AM12L, DM12L, BM12L	80	176
2 inverter/brake modules + integration units (no filter +AE10), IR12L, BR12L	125	276
2 inverter modules + integration units (dU/dt Filter +AEU1), IR12L	178	392
2 inverter modules + integration units (Sine-wave Filter +AES1), IR12L	222	489
2 inverter modules + integration units + SISO-Sine-wave Filter (+AES2), IR12L	322	710
4 inverter modules + integration units + SISO-Sine-wave Filter (+AES2), 2 x IR12L	577	1273
2 AFE/GC/inverter modules + integration units + LC Filter (+AEZ1), AR12L, IR12L	230	507
2 AFE/GC/inverter modules + integration units+ SISO-LC Filter (+AEZ2), AR12L, IR12L	330	728
4 AFE/GC/inverter modules + integration units+ SISO-LC Filter (+AEZ2), 2 x AR12L, 2 x IR12L	593	1308
2 AFE/GC modules + integration units + LCL Filter (+AEZ3), AR12L	230 + OF7Z5 ⁽¹⁾	507 + OF7Z5 ⁽¹⁾
AFE/GC module + integration unit + SISO-LCL Filter (+AEZ4), AR10L	247	545
2 AFE/GC modules + integration units + SISO-LCL Filter(+AEZ4), AR12L	404	891
4 AFE/GC modules + integration units + L Filter + CM Filter (+AEZ4), 2 x AR12L	718	1584
2 DC/DC converter modules + integration units (DC Filter +AED1), DR12L	230	507
Short integration unit (xR10L) +AE01	61	134
Short integration unit (xR12L) +AE01	110	243

1) The size of the external L Filter OF7Z5 and number of filters depend on the number of parallel AR12L modules. See the weights for OF7Z5 in [Table 6](#).

When a system module is ordered without an integration unit, the weights of the filters alone can be seen in [Table 6](#).

Table 6: Weights of the Liquid-cooled Filters

Product	Weight [kg]	Weight [lb]
dU/dt Filter for IM10L, OF7U1	52	115
dU/dt + Common-mode Filter for IM10L, OF7U2	62	137
dU/dt Filter for IM12L, OF7U1	130	287
LC Filter for AM10L, OF7Z1	70	154
LC Filter for AM12L, OF7Z1	130	287
Sine-wave Filter for IR12L, OF7S1SM	130	287
L filter (input side) for AM10L/AR10L, 400 A, OF7Z5	36	80
L filter (input side) for AM12L/AR12L, 1000 A, OF7Z5	74	163
L filter (input side) for AM12L/AR12L, 1640 A, OF7Z5	125	276
L filter (input side) for AM12L/AR12L, 2300 A, OF7Z5	142	313
DC filter for DM10L, OF7D1	70	154
DC filter for DM12L, OF7D1	130	287
SISO-LC Filter, OF7SI2, SILC10L	145	320
SISO-LC Filter, OF7SI2, SILC12L	230	507

Table 6: Weights of the Liquid-cooled Filters - (continued)

Product	Weight [kg]	Weight [lb]
SISO-LC Filter, OF7SI2, SILC14L	400	882
SISO-LCL Filter, OF7SI4, SILCL10L	180	397
SISO-LCL Filter, OF7SI4, SILCL12L	310	683
SISO-LCL Filter, OF7SI4, SILCL14L	515	1135
SISO-Sine-wave Filter, OF7SO2, SOSIN12L	230	507
SISO-Sine-wave Filter, OF7SO2, SOSIN14L	400	882

4.6 Common DC-bus Drive System

A common DC-bus drive system consists of 1 or more front-end modules (AFE, GC, or NFE) that convert the mains AC voltage into DC voltage and current, providing power to the common DC bus. A grid converter can also be used to form a local AC grid.

The common DC bus transfers the power to the inverter modules. The regenerative braking energy of an inverter can be used by the other inverters.

A common DC-bus drive system can also include a brake chopper unit or a DC/DC converter and an energy storage.

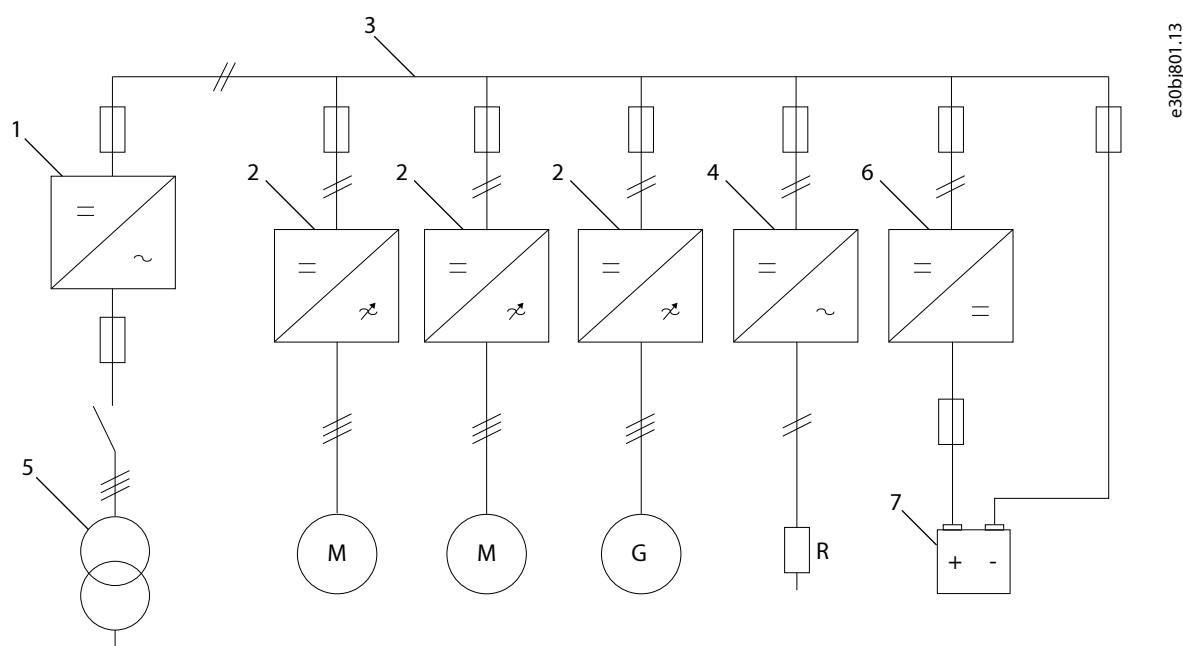

Figure 7: An Example of a Common DC-bus Drive System

1	AFE, GC, or NFE	2	Inverter module
3	DC bus	4	Brake chopper
5	Mains transformer	6	DC/DC converter
7	Energy storage		

4.7 Description of the Model Code

The model code defines the specifications of the product included in the delivery. It is shown on the package label. The model code is made of standard codes and plus codes. Each part of the model code corresponds to the data in the order.

The model code can have this format, for example:

iC7-60SLIN07-300AE00F4+XXXX(+XXXX)

Table 7: Description of the Model Code

Code	Description
iC7-60	Product group
SL	Product category SL = System module, liquid-cooled
IN	Product type 3A = 3-phase active front-end, AFE GC = Grid converter module, GC IN = Inverter module, INU DC = DC/DC converter, DC BR = Brake chopper unit, BR
07	Voltage rating 07 = 525–690 V AC (640–1100 V DC) G7 = 380–690 V AC (500–1500 V DC) B5 = 380–500 V AC (425–830 V DC) A5 = 380–500 V AC (425–830 V DC)
-300A	Current rating ($I_{L(1/5)}$) -03A0 = 3 A -300A = 300 A -3000 = 3000 A
E00	Protection rating E00 = IP00/Open type
F4	EMC level F3 = C3 industry environment F4 = C4 system component
+XXXX	Options See separate list.

4.8 Options

Table 8: Options for the System Modules

Option group	Plus code	Description
Extension, integration unit	+AEXX	None
	+AE01	Short integration unit
	+AE10	Standard, no filter
	+AEZ1	Standard, with LC filter
	+AEZ2	Standard, with SISO LC filter
	+AEZ3	Standard, with LCL filter
	+AEZ4	Standard, with SISO LCL filter
	+AEU1	Standard, with dU/dt filter
	+AEU2	Standard, with dU/dt + CM filter
	+AES1	Standard, with sine-wave filter
	+AES2	Standard, with SISO sine-wave filter
	+AED1	Standard, with DC/DC filter
Marine construction	+AFXX	None
	+AFMC	Power terminal adapter
Mains input device	+AJXX	None
	+AJFX	AC fuses
DC fuses & devices	+AKXX	None
	+AKFX	DC-bus fuses
	+AKFE	DC source and DC-fuses
	+AKFF	DC-bus fuses and source fuses
Cooling circuit connector type	+ANNC	Threaded connection, BSP G1/2" (ISO 228-1)
	+ANN1	Push-in connection
Cooling circuit hose length	+AONH	None
	+AO20	2.0 m (6 ft)
Communication interface, X1/X2	+BAEC	EtherCAT
	+BAEL	Ethernet port, no protocol
	+BAIP	EtherNet/IP
	+BAPR	PROFINET RT OS7PR
	+BAMT	Modbus TCP OS7MT
Communication interface, X0	+BBEL	Ethernet port, no protocol
Standard I/O	+BDXX	None
	+BDC1	I/O and Relay Option OC7C1
	+BD00	None, without mounting plate
Functional Safety	+BEXX	None, not upgradable
	+BEF2	STO, SS1-t

Table 8: Options for the System Modules - (continued)

Option group	Plus code	Description
Control panel	+BFXX	None
	+BF20	Control Panel 2.8 OPX20
Control panel mounting type	+BGXX	None
	+BGK1	Flush mount
Control panel cable length	+BHXX	None
	+BH15	1.5 m (5 ft)
	+BH25	2.5 m (8 ft)
	+BH50	5.0 m (16 ft)
	+BHA0	10.0 m (32 ft)
Control unit cable length	+BKXX	None
	+BK03	0.3 m (1 ft), fiber
	+BK05	0.5 m (1 ft), fiber
	+BK15	1.5 m (5 ft), fiber
	+BK25	2.5 m (8 ft), fiber
	+BK50	5.0 m (16 ft), fiber
	+BK75	7.5 m (24 ft), fiber
	+BKA0	10.0 m (32 ft), fiber
Star coupler board cable length	+BLXX	None
	+BL15	1.5 m (5 ft), fiber
	+BL25	2.5 m (8 ft), fiber
	+BL50	5.0 m (16 ft), fiber
	+BL75	7.5 m (24 ft), fiber
	+BLA0	10.0 m (32 ft), fiber
	+BLA5	15.0 m (50 ft), fiber
Control options	+C_XX	None, without mounting plate
	+C_X0	None
	+C_C0	General Purpose I/O OC7C0
	+C_C1	I/O and Relay Option OC7C1
	+C_R0	Relay Option OC7R0
	+C_M0	Encoder/Resolver Option OC7M0
	+C_T0	Temperature Measurement OC7T0
Technical documentation	+EGXX	None
	+EGIN	Installation guide
Documentation language	+EHXX	Multi-language
	+EHEN	English

Table 8: Options for the System Modules - (continued)

Option group	Plus code	Description
Language pack	+EL01	Global
Shipping package	+TACB	Cardboard box package
	+TASE	Sea container package
Product-specific marine certification	+VBXX	None
	+VBAB	American Bureau of Shipping
	+VBBV	Bureau Veritas
	+VBDN	DNV
	+VBIN	Registro Italiano Navale
	+VBCN	China Classification Society
	+VBNP	ClassNK

4.9 Labels on the Products

4.9.1 Labels on the System Module

To provide information about the product and the system modules, several labels are placed in the front of the modules.

- Product label
 - Includes the model code and other information about the product. See [4.7 Description of the Model Code](#).
 - See [4.9.3 Product Label](#).
 - When the product includes several system modules, the product label is only placed on the 1st module on the left-hand side of the lineup.
 - The product label is on a detachable plate. If the module is replaced, remove the label plate and mount it on the new module.
- Power unit label
 - Includes information about the system module.
 - The information on the label is specific to each system module.
 - Includes the serial number of the product to which the system module belongs.
- Marine approvals label
 - List of approvals for the product.
- Product modified label
 - List of changes done to the module.
 - See [9.3 Using the Product Modified Label](#).
- Power module label
 - Label for identifying the power module.

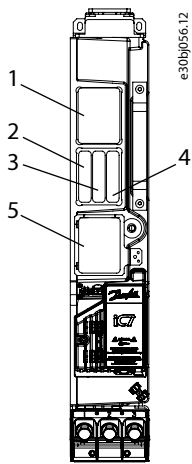

Figure 8: Locations of the Labels on the System Module

1	Power unit label	2	Marine approvals label
3	Product modified label	4	Power module label
5	Product label		

4.9.2 Labels on other Components

There is an identification label on the components to provide information about the part, and about which product and system modules the component belongs. It is important to match the components with the correct product and system modules.

The identification label on control units and star coupler boards includes:

- Name of the component and information on which system modules the component belongs to, for example, "Control for 4xAR12L" or "Star for 3xIR10L".
- The serial number (S/N) of the product to which the component belongs, for example, DC1234XZ. This code is also shown in a small QR code.
- Code for the component, for example, 137G2222.
- QR code, which shows the model code of the product to which this component belongs.

There are similar identification labels on the integration units, filters, subassemblies, and other components. For example, the label on L Filters includes:

- Information about the filter.
- The serial number (S/N) of the product to which the filter belongs.

The control board, star coupler board, and option boards also have a product label on the side of the board. The product labels include:

- The name of the board
- Product code, serial number, and reference number
- For control boards and star coupler boards: Ethernet port MAC address information
- For option boards: Information about terminals (for details, see the guide of the option board)

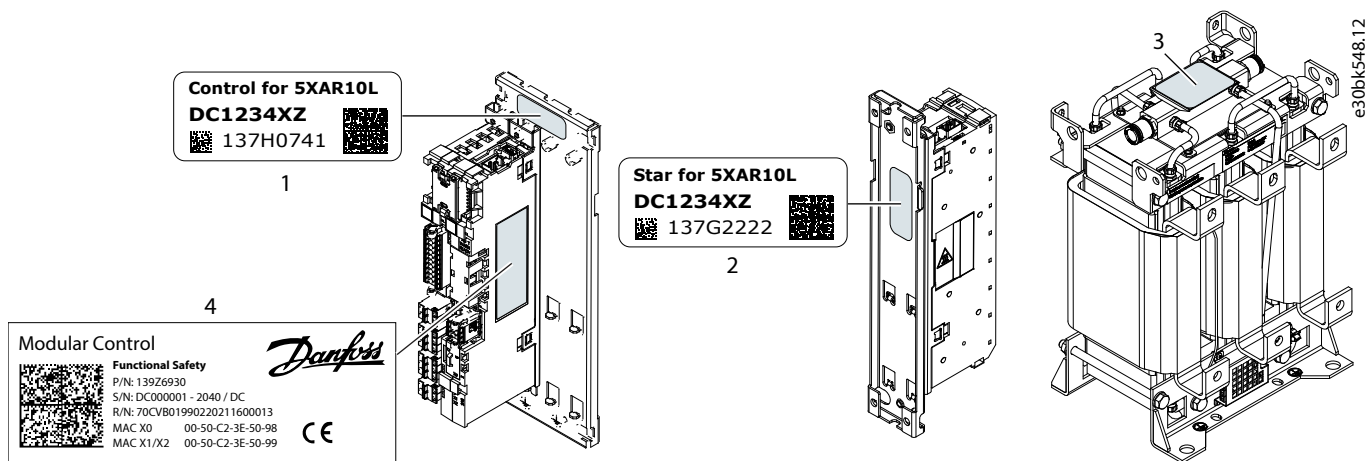
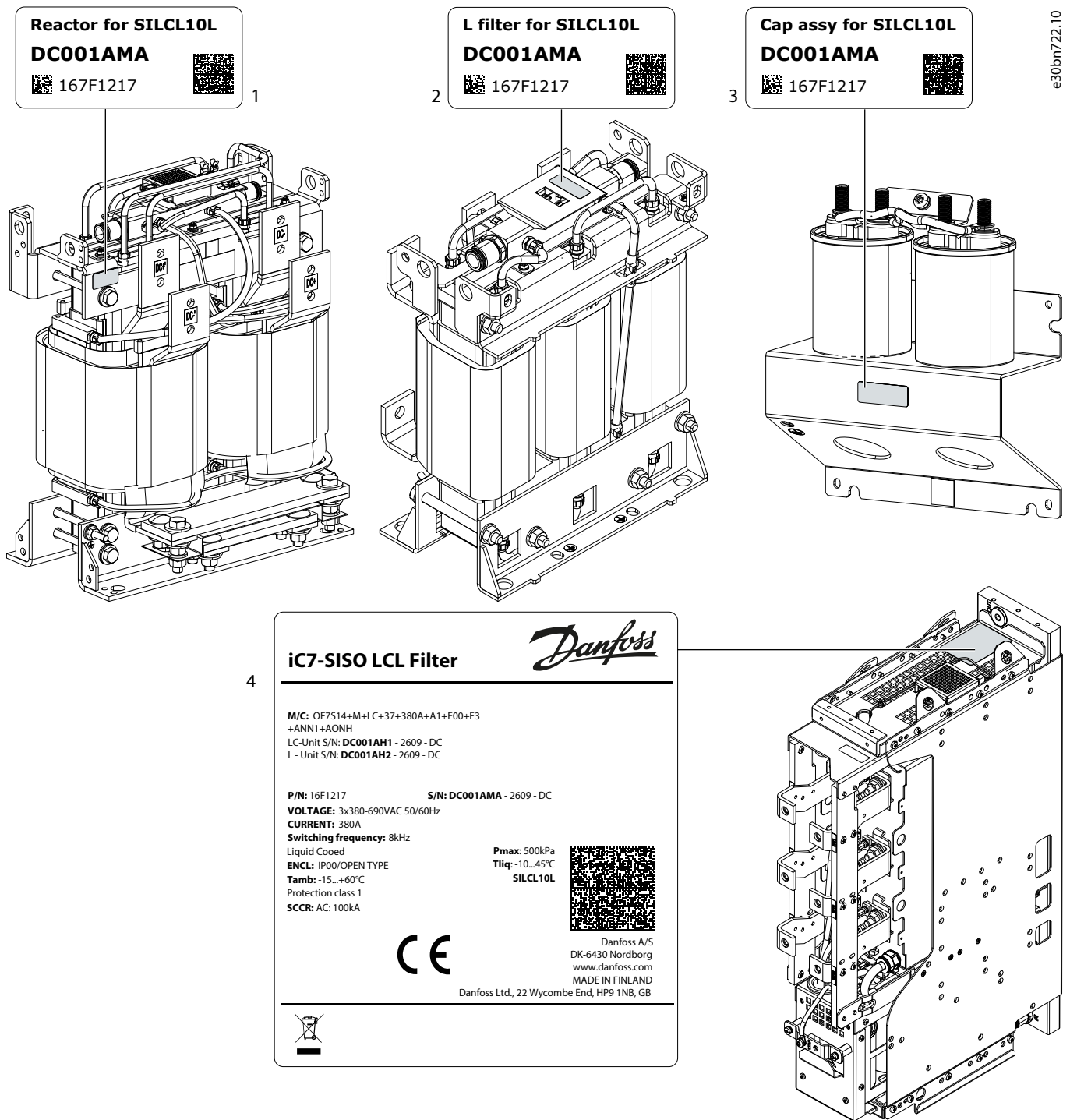

Figure 9: Locations of Labels on the Components

1	Identification label on the control unit	2	Identification label on the star coupler board
3	Label on the L Filter	4	Product label on the control board



e30bn722.10

Figure 10: Location of Labels on the Components, SISO Filter

- | | | | |
|---|---|---|--------------------------------------|
| 1 | Identification label on the reactor | 2 | Identification label on the L-filter |
| 3 | Identification label on the feedback capacitors | 4 | Product label LCL filter |

4.9.3 Product Label

The product label gives information about the product.

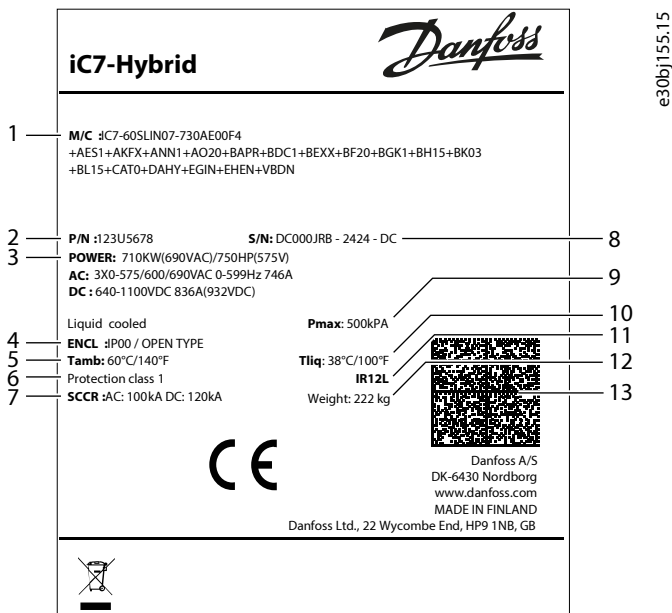

Figure 11: Product Label for iC7 Series Liquid-cooled System Modules

1	Model code of the product	2	Code number
3	Power, input, and output ratings	4	Protection rating
5	Temperature rating for ambient air	6	Protection rating
7	Short-circuit current rating	8	Serial number
9	Maximum continuous coolant pressure	10	Temperature rating for coolant
11	Frame designation	12	Weight
13	2D code accessible with a Datamatrix ECC 200 compatible barcode reader		

4.10 Lifting the Product

4.10.1 Lifting the System Modules

1. Attach the lifting device in the hole on the top of the system module.
2. If necessary, lift the system module into a vertical position.

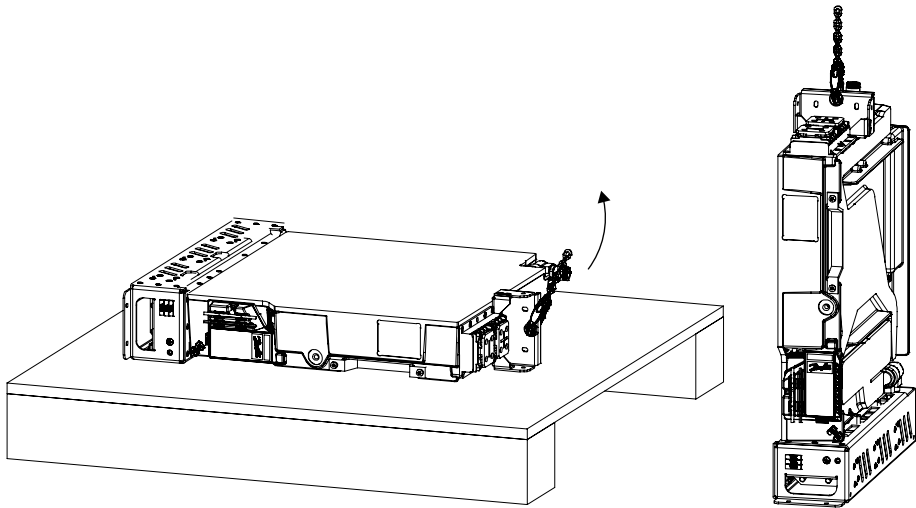

e30bh498.11

Figure 12: Lifting the System Module

3. Lift the system module to the required location.

4.10.2 Lifting the System Modules with Integration Unit

1. Place the lifting hooks in 4 holes at the top of the system module.

A product with a short integration unit has the same lifting holes.

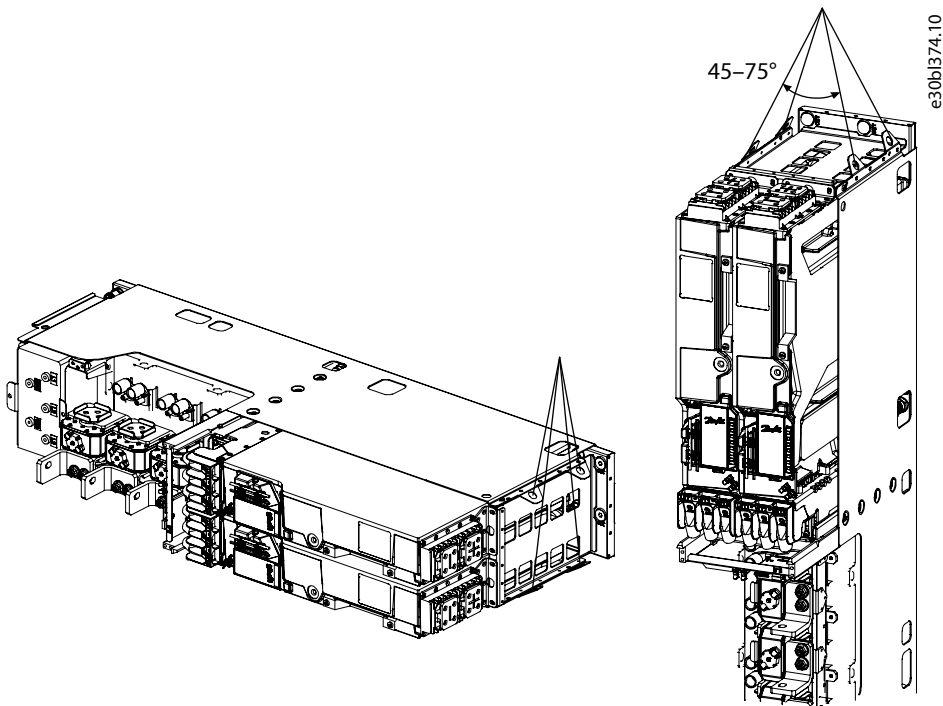

e30b1374.10

Figure 13: Lifting the System Module with Integration Unit

2. If necessary, lift the system module into a vertical position.

The recommended lifting angle is $60^\circ \pm 15^\circ$.

3. Lift the system module to the required location.

4.10.3 Lifting the Filters

Use these instructions to lift the L Filter, the LC Filter, the dU/dt Filter, the dU/dt and Common-mode Filter, and the DC/DC Filter.

1. Place the lifting hooks in 4 holes at the top of the filter.
2. If necessary, lift the filter into a vertical position.

The recommended lifting angle is $60^\circ \pm 15^\circ$.

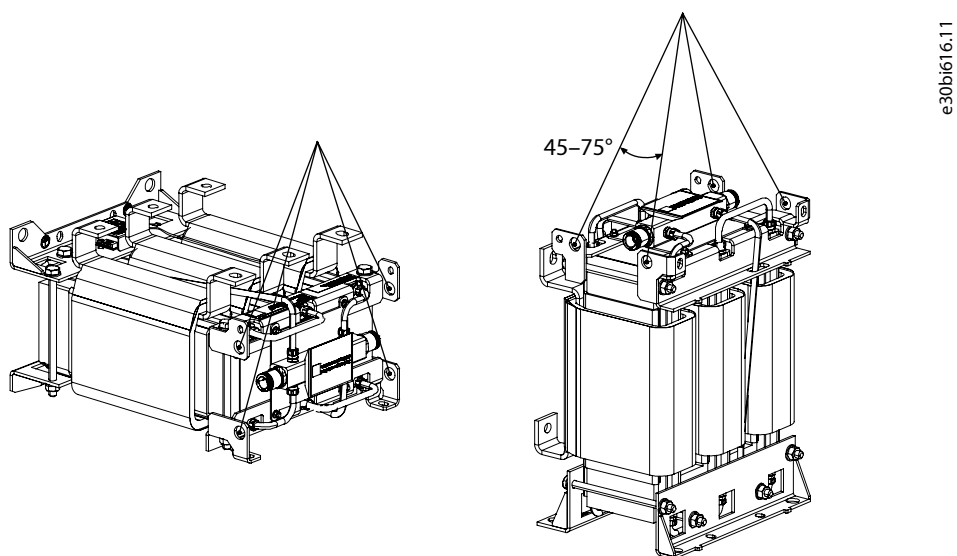

Figure 14: Example: Lifting the L Filter

3. Lift the filter to the required location.

5 Mechanical Installation Considerations

5.1 Storing the System Module

If it is necessary to store the product before installing it, follow these instructions. Keep the equipment sealed in its packaging until installation.

1. Make sure that the ambient conditions correspond to these:
 - o Temperature: -40...+70 °C (-40...+158 °F)
 - o Humidity: 0...95%, condensation must be avoided
2. If the package is kept in storage for more than 2 months, keep it in controlled conditions.
 - a. Make sure that the temperature variation is small.
 - b. To avoid corrosion, make sure that the humidity is less than 50%.

5.2 Requirements for the Cabinet

The products that are described in this guide have the protection rating IP00/Open Type and do not have an enclosure. They must be installed in a cabinet or other enclosure that has a correct level of protection against the ambient conditions in the installation area. Make sure that the cabinet gives protection against water, humidity, dust, and other contaminations.

The mounting surface of the cabinet must be non-combustible.

The cabinet must also be sufficiently strong to carry the weight of the system module and other devices. It is recommended to use a free-standing, floor-mounted cabinet made of sheet metal.

The maximum temperature of the air inside the cabinet is +60 °C (+140 °F).

The protection rating of the cabinet must be at least IP21/UL Type 1. When preparing the installation, obey the local regulations.

5.3 Mechanical Installation

5.3.1 Installation Requirements

The system modules that are described in this guide have the protection rating IP00/Open Type. Install them in a cabinet or other enclosure that has a correct level of protection against the ambient conditions in the installation area.

The installation procedure varies between product categories and mechanical variants depending on selected options.

Reserve enough space around the system module to ensure sufficient cooling. The mounting plane must be relatively even.

5.3.2 Installation Directions

NOTICE

Do not install the system module upside down or the front side facing down.

The system module can be installed vertically, horizontally, and on its backside.

5.3.3 Installing System Modules

5.3.3.1 Installing System Modules into a Cabinet Vertically

1. Install the system module into the cabinet in a vertical position.
2. Use mounting holes to attach the system module into the cabinet.
 - a. Use M6 grade 8.8 screws.
 - b. For an AM12L or IM12L, use M8 grade 8.8 screws for the lower parts.

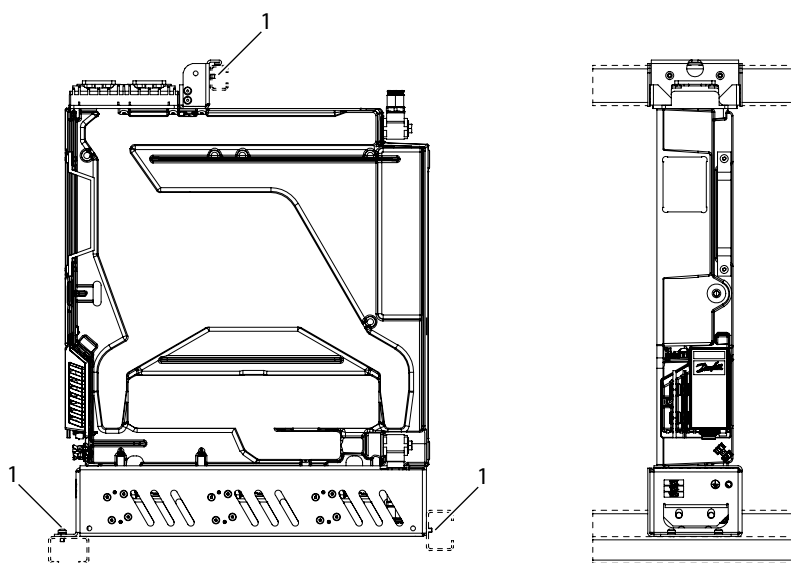

e30bh576.11

Figure 15: Mounting Holes of the System Module in Vertical Position

1 Mounting holes

3. Attach the system module to the mounting brackets of the cabinet.

The mounting brackets are not included in the delivery.

a. To ease the removal of the system module from the cabinet for service, use support bars under the system module.

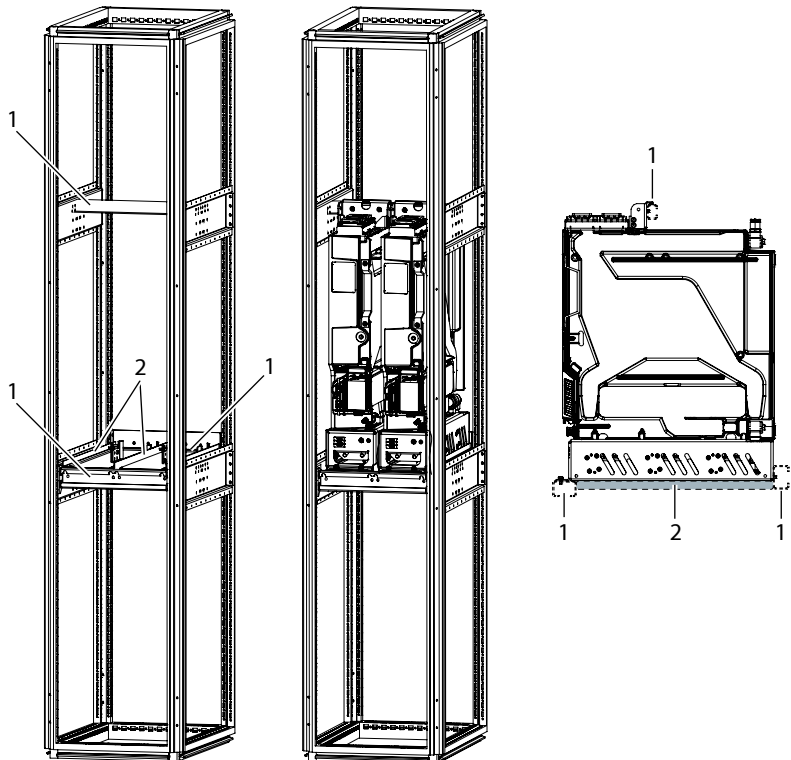

e30bh511.12

Figure 16: The Mounting Brackets and the Installation of System Modules into the Cabinet

1 Mounting brackets

2 Support bars

5.3.3.2 Installing System Modules into a Cabinet Horizontally

1. Install the system module into the cabinet in a horizontal position on its side.

Make sure that the cover plate is pointing up. See [Figure 17](#).

2. Use mounting holes to attach the system module into the cabinet.
 - a. Use M6 grade 8.8 screws.
 - b. For an AM12L or IM12L, use M8 grade 8.8 screws for the lower parts.

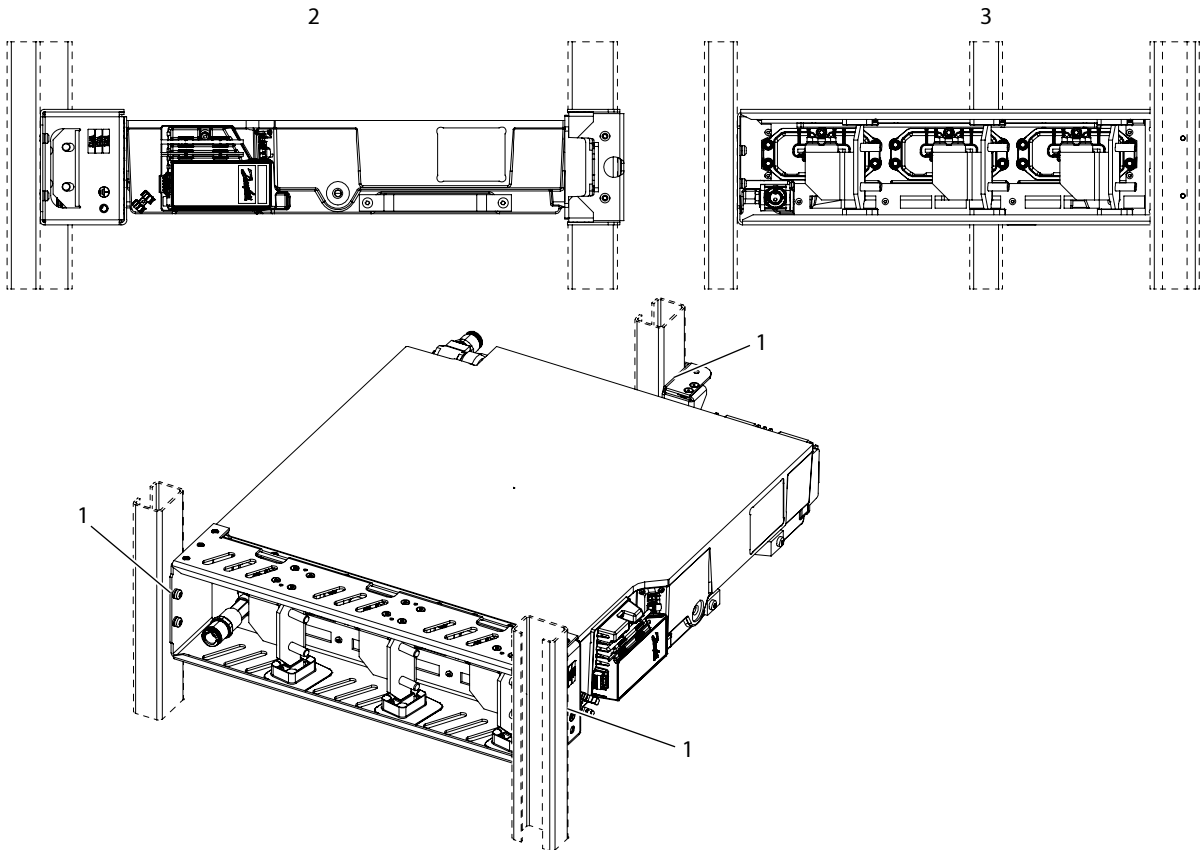

e30bh577.11

Figure 17: Mounting Holes of the System Module in Horizontal Position

1	Mounting holes	2	View from the front
3	View from the bottom		

3. Attach the system module to the mounting brackets of the cabinet.

The mounting brackets are not included in the delivery.

5.3.3.3 Installing System Modules into a Cabinet on their Backsides

1. Install the system module into the cabinet on its backside.
2. Use mounting holes to attach the system module into the cabinet.
 - a. Use M6 grade 8.8 screws.
 - b. For an AM12L or IM12L, use M8 grade 8.8 screws for the lower parts.

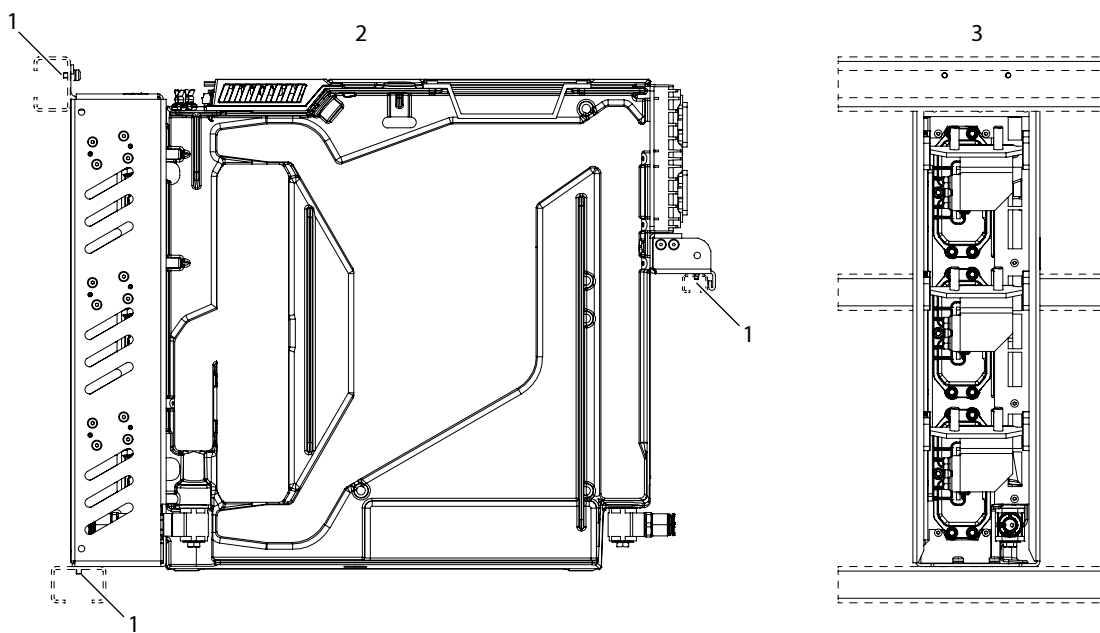

e30bh578.11

Figure 18: Mounting Holes of the System Module on its Backside

1	Mounting holes	2	View from the side
3	View from the bottom		

3. Attach the system module to the mounting brackets of the cabinet.

The mounting brackets are not included in the delivery.

5.3.4 Installing System Modules with Integration Units

5.3.4.1 Installing System Modules with Integration Units into a Cabinet Vertically

1. Install the system module into the cabinet in a vertical position.
2. Use mounting holes to attach the system module into the cabinet.
 - a. For aluminum parts, use M6 grade 8.8 screws with a thread depth of 6–14 mm (0.24–0.55 in), and a tightening torque of 6–8 Nm (53–71 in-lb).
 - b. For sheet metal parts, use M5 (DIN 7500) thread-forming screws with a maximum thread depth of 20 mm (0.78 in), and a tightening torque of 3–4 Nm (27–35 in-lb).

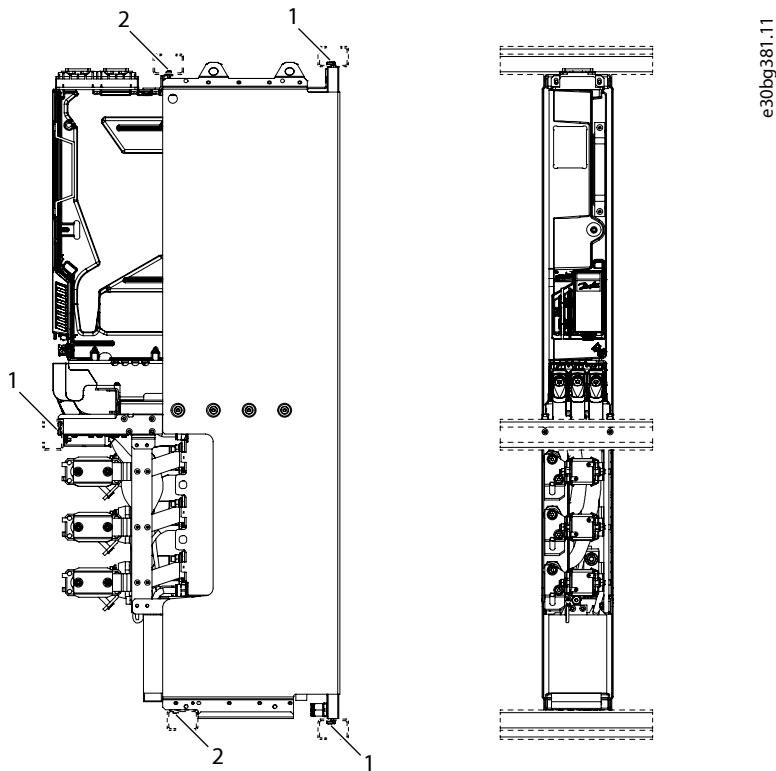

Figure 19: Mounting Holes of the System Module, AFE with the Integration Unit

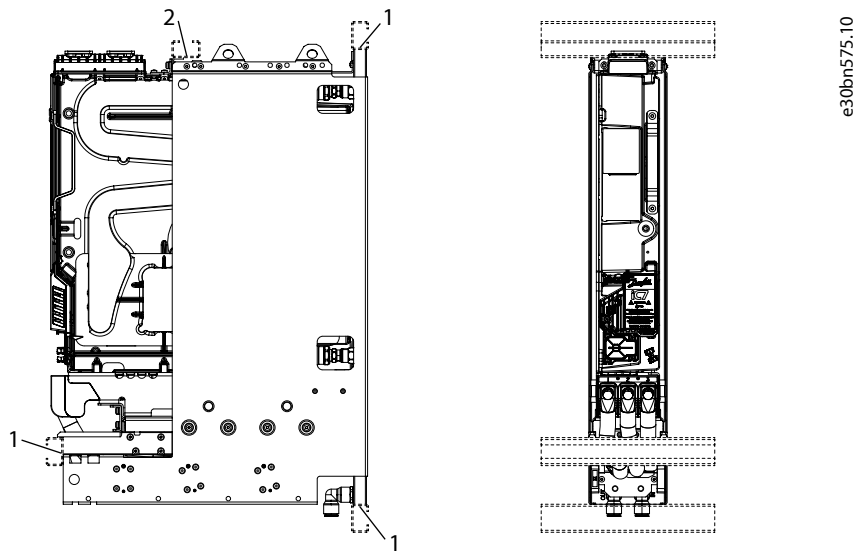

Figure 20: Mounting Holes of the System Module with Short Integration Unit (+AE01)

- | | |
|--|---|
| 1 Mounting holes in aluminum parts | 2 Mounting holes in sheet metal parts |
|--|---|

3. Attach the system module to the mounting brackets of the cabinet.

The mounting brackets are not included in the delivery.

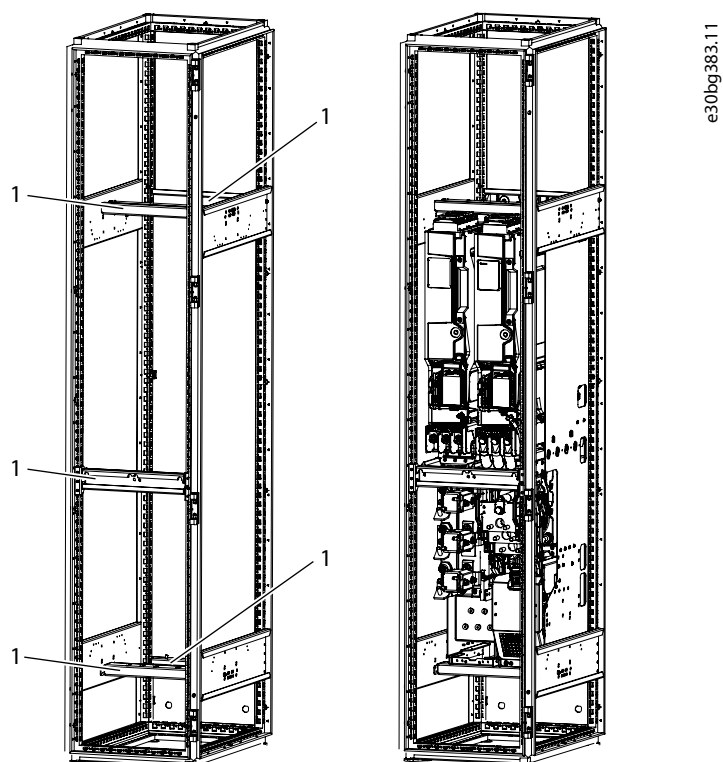

Figure 21: The Mounting Brackets and the Installation of System Modules with the Integration Unit into the Cabinet

-
- 1 Mounting brackets
-

5.3.4.2 Installing System Modules with Integration Units into a Cabinet Horizontally

1. Install the system module into the cabinet in a horizontal position on its side.

Make sure that the cover plate is pointing up. See [Figure 22](#).

2. Use mounting holes to attach the system module into the cabinet.
 - a. For aluminum parts, use M8 grade 8.8 screws with a thread depth of 6–14 mm (0.24–0.55 in), and a tightening torque of 6–8 Nm (53–71 in-lb).
 - b. For sheet metal parts, use M5 (DIN 7500) thread-forming screws with a maximum thread depth of 20 mm (0.78 in), and a tightening torque of 3–4 Nm (27–35 in-lb).

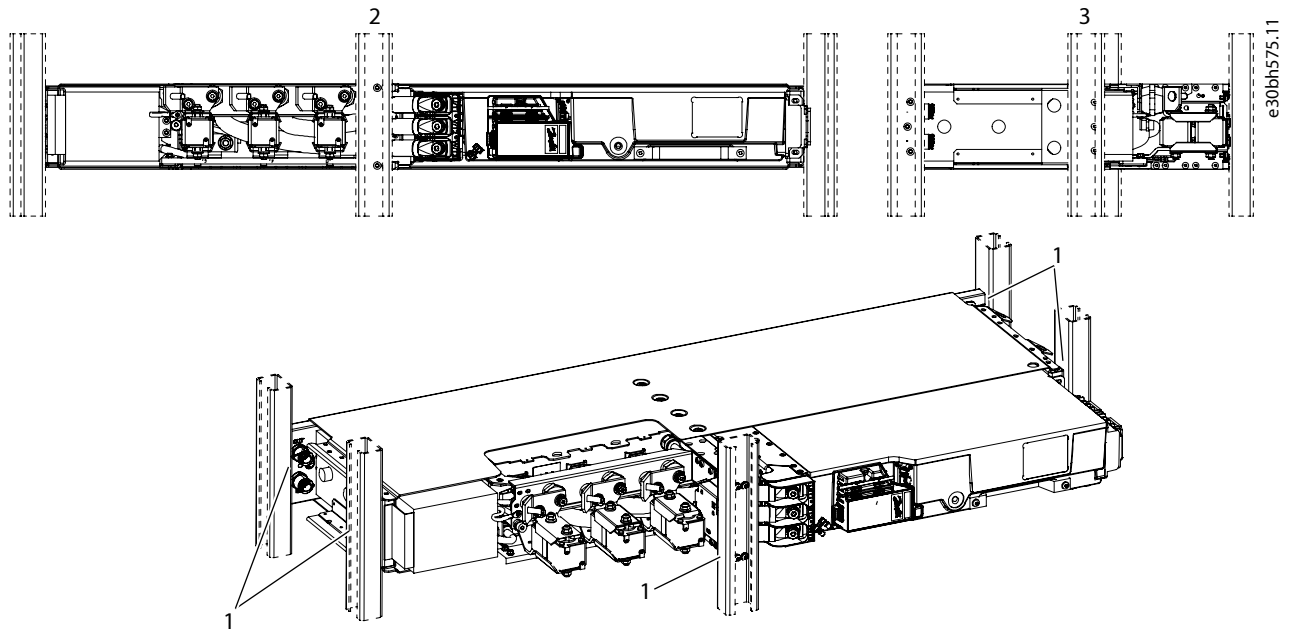
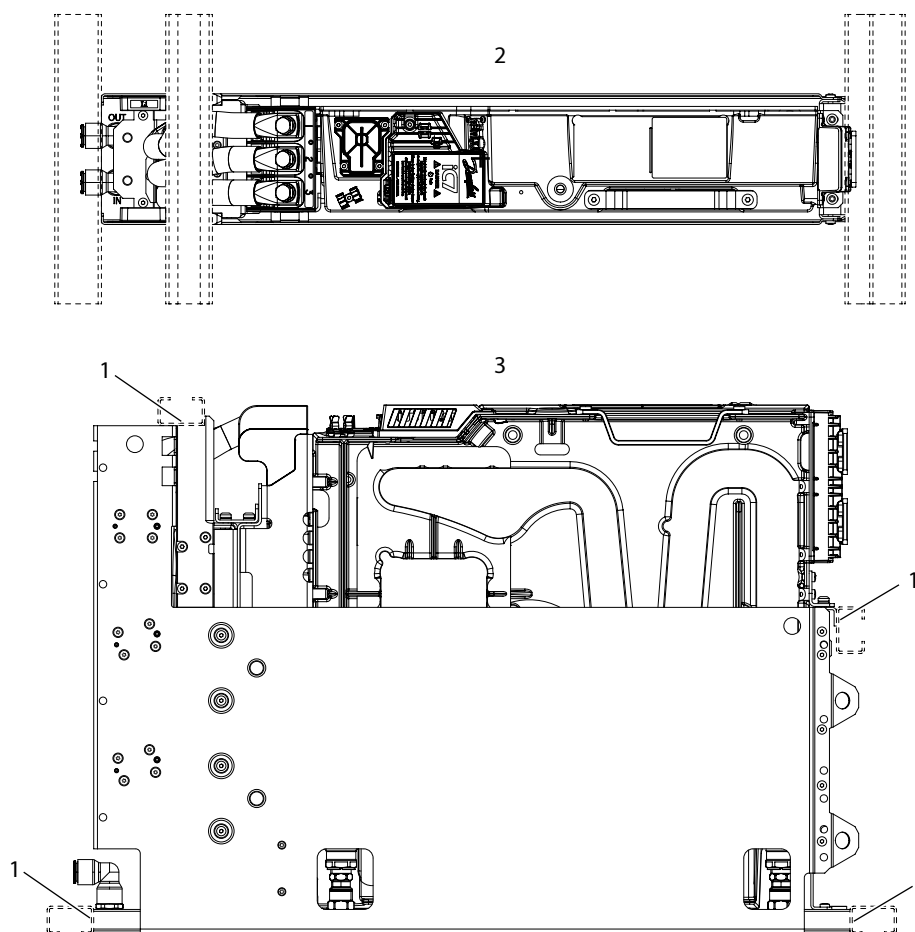

Figure 22: Mounting Holes of the System Module with the Integration Unit in Horizontal Position

- | | | | |
|---|----------------------|---|---------------------|
| 1 | Mounting holes | 2 | View from the front |
| 3 | View from the bottom | | |



e30bn655.10

Figure 23: Mounting Holes of the System Module with Short Integration Unit (+AE01) in Horizontal Position

1	Mounting holes	2	View from the front
3	View from below		

3. Attach the system module to the mounting brackets of the cabinet.

The mounting brackets are not included in the delivery.

5.3.4.3 Installing System Modules with Integration Units into a Cabinet on their Backsides

1. Install the system module into the cabinet on its backside.
2. Use mounting holes to attach the system module into the cabinet.
 - a. For aluminum parts, use M6 grade 8.8 screws with a thread depth of 6–14 mm (0.24–0.55 in), and a tightening torque of 6–8 Nm (53–71 in-lb).
 - b. For sheet metal parts, use M5 (DIN 7500) thread-forming screws with a maximum thread depth of 20 mm (0.78 in), and a tightening torque of 3–4 Nm (27–35 in-lb).

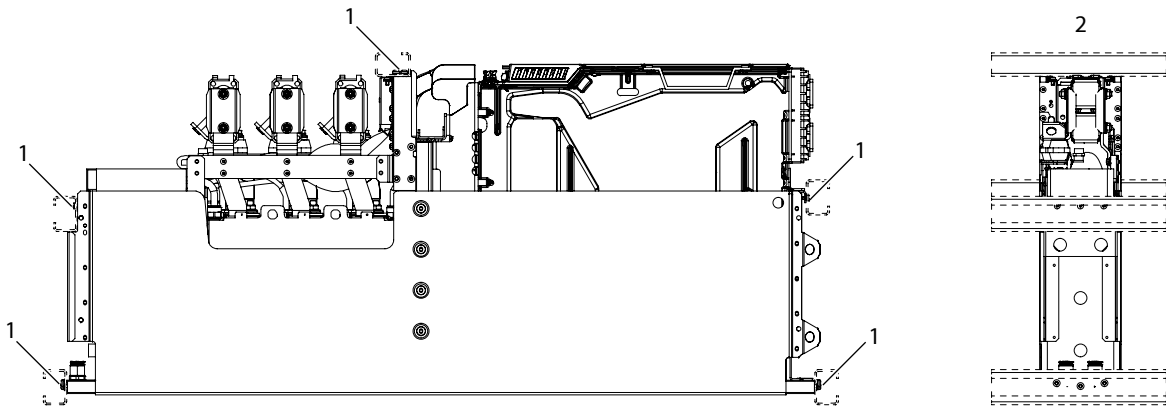

e30bh512.11

Figure 24: Mounting Holes of the System Module with the Integration Unit on its Backside

- | | | | |
|---|----------------|---|------------------------------------|
| 1 | Mounting holes | 2 | View from the bottom of the module |
|---|----------------|---|------------------------------------|

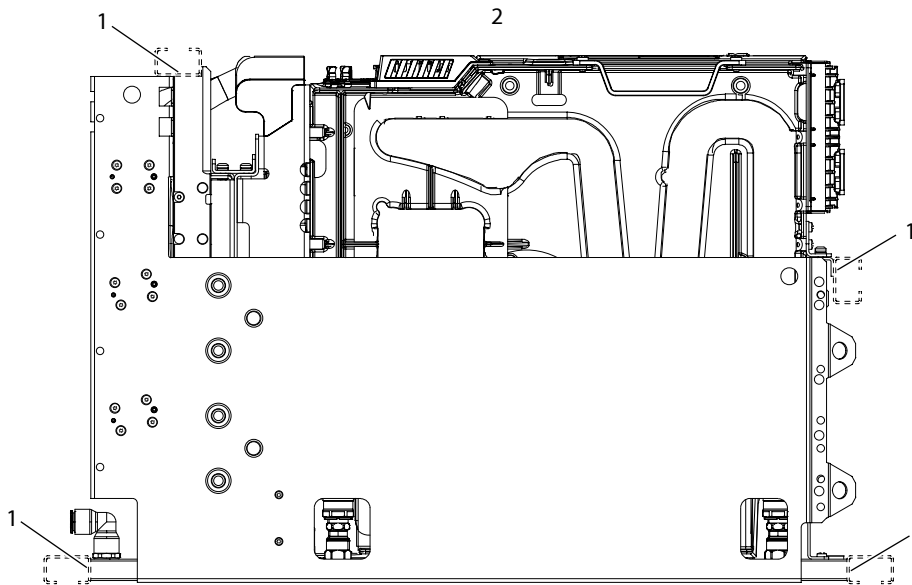

e30bn658.10

Figure 25: Mounting Holes of the System Module with Short Integration Unit (+AE01) on its Backside

- | | | | |
|---|----------------|---|--------------------|
| 1 | Mounting holes | 2 | View from the side |
|---|----------------|---|--------------------|

- Attach the system module to the mounting brackets of the cabinet.

The mounting brackets are not included in the delivery.

5.3.5 Installing Filters

5.3.5.1 Installing L Filter into a Cabinet, 400 A and 1000 A

- Install the filter into the cabinet in a vertical position.
- Align the filter so that the pins of the filter fit into the square holes at the back wall of the cabinet.

Check the precise location of the pins in the dimensional drawing of the filter.

- [10.2.13 Dimensions of the L Filter, 400 A](#)
- [10.2.14 Dimensions of the L Filter, 1000 A](#)

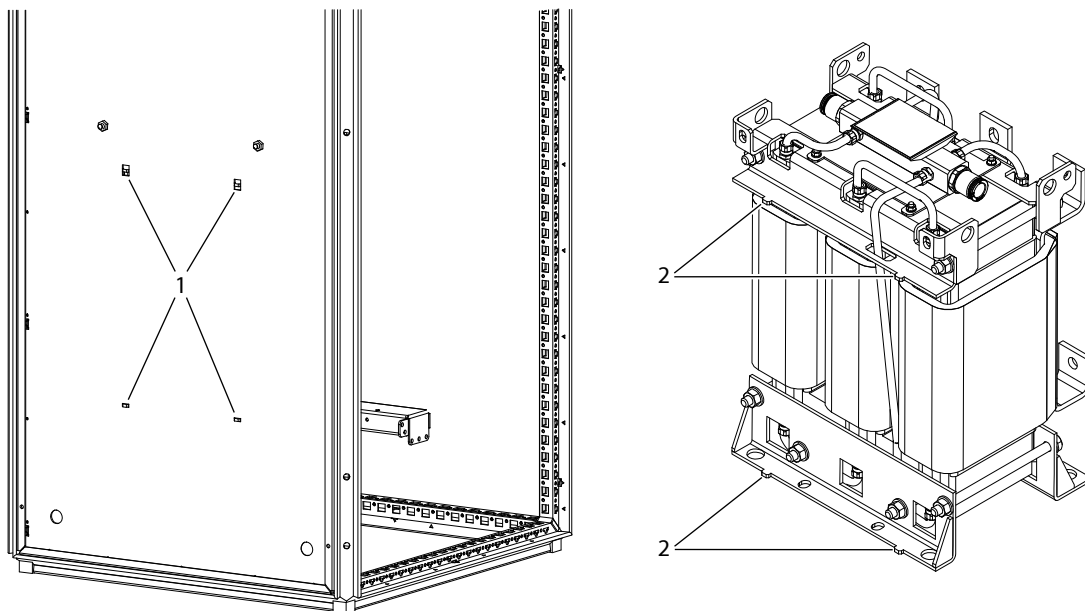

e30bm625.10

Figure 26: Aligning the Filter Pins with the Back Wall

- | | | | |
|---|-----------------------|---|------|
| 1 | Square mounting holes | 2 | Pins |
|---|-----------------------|---|------|

- Use the mounting holes to attach the filter. Attach the filter from all these corners: top back, bottom front, and bottom back.

Check the precise location of the mounting holes in the dimensional drawing of the filter.

- [10.2.13 Dimensions of the L Filter, 400 A](#)
- [10.2.14 Dimensions of the L Filter, 1000 A](#)

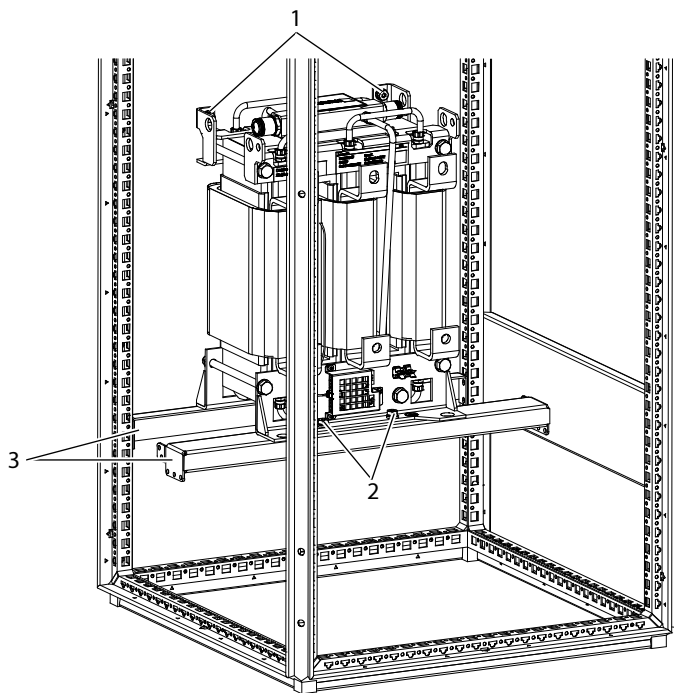

e30bl375.11

Figure 27: Installing the L Filter into a Cabinet (400 A, 1000 A)

- | | |
|--|---|
| <p>1 The mounting holes at the top</p> <p>3 Brackets</p> | <p>2 The mounting holes at the bottom</p> |
|--|---|

4. Use brackets to attach the filter from below.

The mounting brackets are not included in the delivery.

5.3.5.2 Installing L Filter into a Cabinet, 1640 A and 2300 A

1. Install the filter into the cabinet in a vertical position.

The filter can also be installed upside down.

2. Use the mounting holes to attach the filter.

- a. Attach the filter from all the corners: top front, top back, bottom front, and bottom back.

Check the precise location of the mounting holes in the dimensional drawing of the filter.

- o [10.2.15 Dimensions of the L Filter, 1640 A](#)
- o [10.2.16 Dimensions of the L Filter, 2300 A](#)

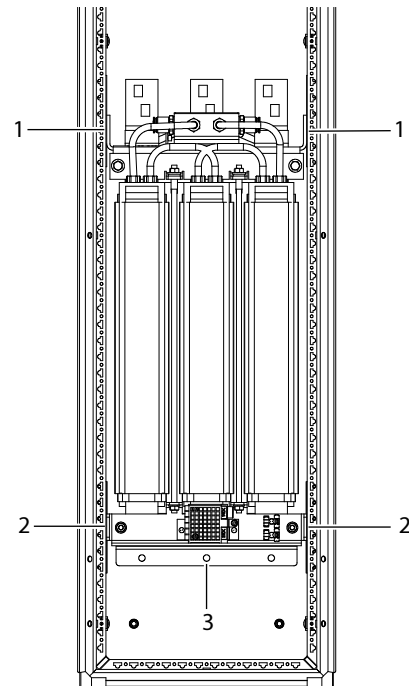
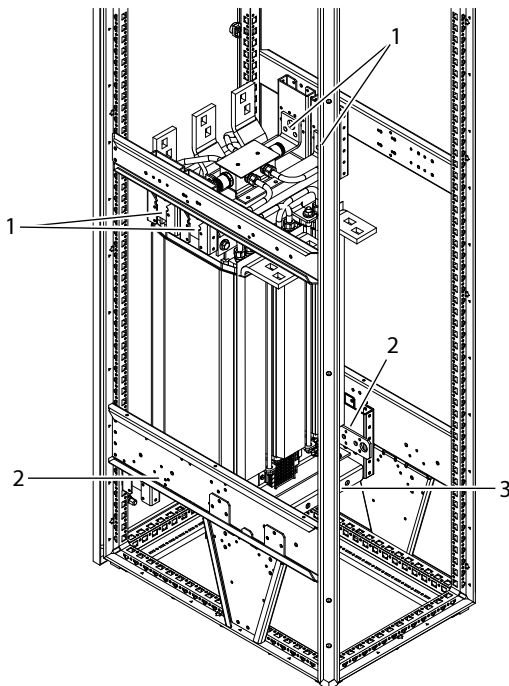

e30bm610.10

Figure 28: Installing the L Filter into a Cabinet (1640 A, 2300 A)

- | | |
|---|---------------------------------------|
| <p>1 Mounting holes at the top</p> <p>3 Brackets below the filter</p> | <p>2 Mounting holes at the bottom</p> |
|---|---------------------------------------|

3. Use brackets to attach the filter from below.

The mounting brackets are not included in the delivery.

 **IMPORTANT:** To make a stable installation, it is important to use brackets.

5.3.5.3 Installing the SISO Filter Feedback Capacitors into a Cabinet

1. Install the capacitors with the terminals upright.

If another mounting orientation is required, make sure that the capacitor bank is properly supported. If necessary, contact Danfoss for instructions.

2. Make sure that the inductors or other components do not heat up the capacitors. For example, install the capacitors and inductors in separate sections.

When selecting the installation location, consider the maximum cable lengths, see [7.5.3 Cable Requirements for SISO Filter](#).

3. Mount the capacitor bank with 4 screws.

For mechanical dimensions and the positions of the mounting holes, see [10.2.20 Dimensions of the Feedback Capacitors](#).

4. Install the fuse holder for the feedback DC fuses on a DIN rail.

6 Cooling Requirements

6.1 Safety in Liquid-cooling

WARNING

POISONOUS COOLANTS

Glycols and inhibitors are poisonous. If touched or consumed, they can cause injury.

- Prevent the coolant from getting into the eyes. Do not drink the coolant.

CAUTION



HOT COOLANT

Hot coolant can cause burns.

- Avoid contact with the hot coolant.

CAUTION

PRESSURIZED COOLING SYSTEM

Sudden release of pressure from the cooling system can cause injury.

- Be careful when operating the cooling system.

NOTICE

INSUFFICIENT COOLING CAPACITY

Insufficient cooling can cause the product to become too hot and thus become damaged.

- To make sure that the cooling capacity of the cooling system stays sufficient, make sure that the cooling system is vented and that the coolant circulates properly even before applying mains power.

NOTICE

DAMAGE TO COOLING SYSTEM

If the coolant circulation is stopped too soon, high-temperature components can cause rapid local increase in the coolant temperature, which can damage the cooling system.

- Do not stop the cooling system when stopping the drive. Keep the coolant circulation flowing for 2 minutes after the drive has been stopped.

6.2 General Information on Cooling

NOTICE

The maximum pressure in the cooling system cannot exceed 5 bar (72.5 psi).

- Equip the cooling system with a relief valve.

The product is cooled with liquid. The liquid circulation of the drive is usually connected to a heat exchanger (liquid-to-liquid or liquid-to-air) that cools down the liquid circulating in the cooling elements of the drive. The cooling elements are made of aluminum. That is why the coolants allowed to be used are demineralized (or deionized, or distilled) water with corrosion inhibitors, or a mixture of this type of water and glycol with corrosion inhibitors.

There are 2 types of circulation system: open systems and closed systems.

Always use a closed system with liquid-cooled drives.

An open system only has the hydrostatic and pumping pressure. It allows free contact between the coolant and air. Air is continuously dissolved into the coolant, which corrodes and damages the components.

In a closed system, the piping is air-tight and there is a preset pressure inside the pipes. The pipes must be made of metal, or a specific plastic or rubber that includes an oxygen barrier that limits the diffusion of oxygen. Minimizing of oxygen content in the coolant decreases the risk of corrosion of the metal parts. Closed systems usually have an expansion tank that allows for a safe change of volume of the coolant due to temperature changes.

The electrical resistance of the plastic and rubber pipes must be $>10^9 \Omega$.

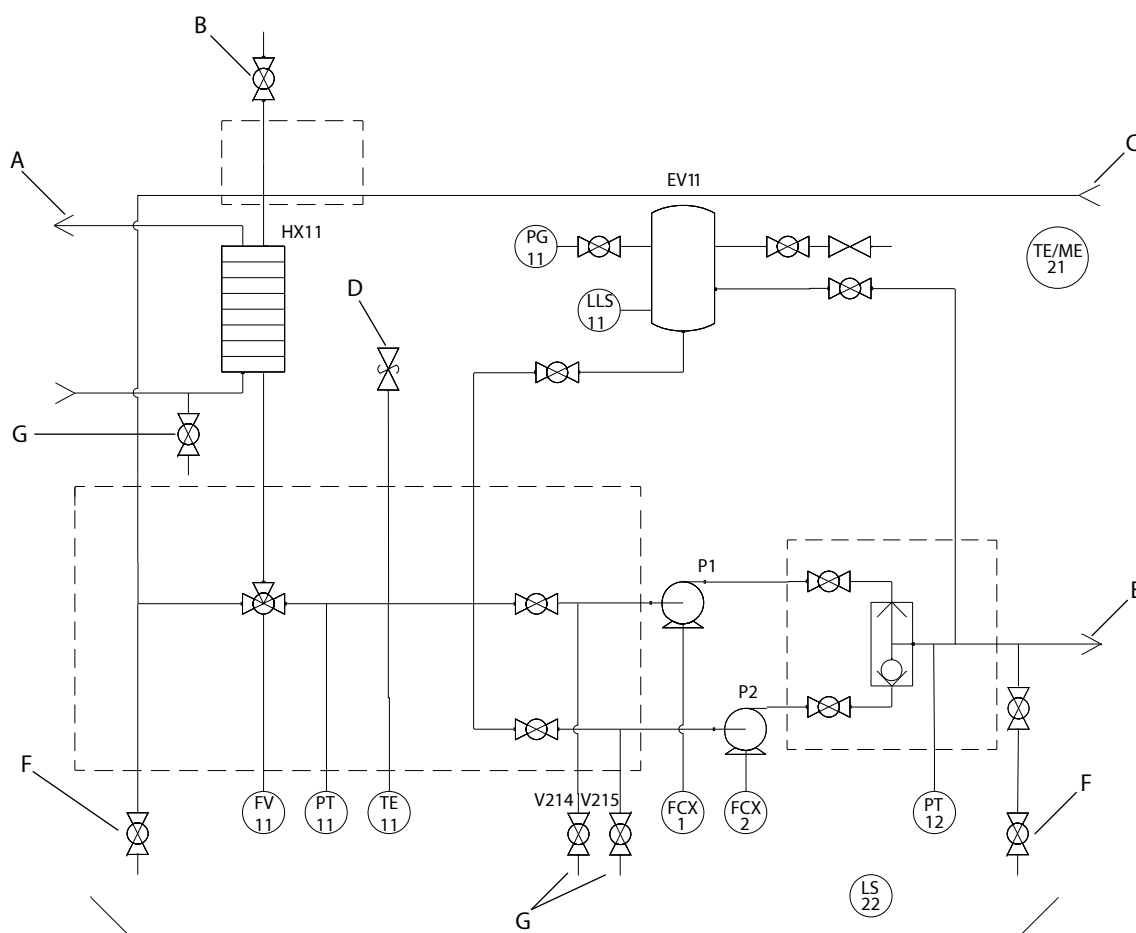

e30bi285.11

Figure 29: Example PID Diagram of the Cooling Circuit

A	Customer cooling circuit	B	De-airing valve
C	Coolant from the drives	D	Relief valve
E	Coolant to the drives	F	Filling and draining
G	Draining		

6.3 Coolant

6.3.1 Quality Requirements for Cooling Water

Use only technical cooling water such as battery water, distilled water, demineralized water, or deionized water.

Incorrect coolant, such as tap water, can cause blockages and corrosion.

NOTICE

DAMAGE TO SYSTEM FROM THE USE OF HYDROCARBONS

Hydrocarbons damage the rubber seals of the cooling system.

- Do not use hydrocarbons (for example mineral oil) as coolant or as a lubricant when installing pipes.
- Do not mix hydrocarbons to the coolant.

Table 9: Requirements for the Cooling Water

Property	Required value
pH	5–8
Electrical conductivity	≤ 10 μS/cm

6.3.2 Purified Water as Coolant

Purified water can be used as coolant if there is no risk of freezing. Freezing water permanently damages the cooling system. Purified water is demineralized, deionized, or distilled water.

Always use an inhibitor Cortec VpCI-649 with 1.0% of volume with purified water.

NOTICE

CORROSION HAZARD WITH DRINKING WATER

Some components are made of aluminum, which has limited corrosion resistance against high chloride concentrations. Drinking water can have a chloride concentration of 250 ppm, which increases the aluminum corrosion rate. High chloride concentration exposes aluminum especially to pitting corrosion which can damage the system relatively quickly.

- Use purified (demineralized, deionized, or distilled) water with corrosion inhibitors.

6.3.3 Antifreeze Mix as Coolant

The following antifreeze products are a good general solution for liquid cooling since they provide freeze protection and corrosion protection.

The allowed antifreeze coolants are the following ethylene glycols and propylene glycols.

Ethylene glycols

- DOWCAL 100
- Clariant Antifrogen N

Propylene glycols

- DOWCAL 200
- Clariant Antifrogen L

These glycols already include corrosion inhibitors. Do not add any other inhibitor. Do not mix different glycol qualities because there can be harmful chemical interactions.

The glycol concentration of the coolant must be 25–55% by volume, according to the specified ambient temperature. Higher concentration reduces cooling capacity. Lower concentration results in biological growth and inadequate amount of corrosion inhibitors. Antifreeze must be mixed with purified water according to [6.3.1 Quality Requirements for Cooling Water](#).

6.3.4 Requirements for the Coolant over the Entire Service Life

The coolant must meet the following requirements over its entire service life.

Table 10: Requirements for the Coolant

Property	Required value
Chlorides	< 25 ppm
Sulfates	< 25 ppm
Total Hardness (CaCO ₃)	< 4.5 dH
Hydrogen Carbonate	< 50 ppm
Maximum particle size	≤ 50 μm

6.3.5 Temperature of the Coolant

To gain full performance of the product, the temperature of the coolant entering the system module must be a maximum of 45 °C (113 °F). While circulating inside the cooling element, the liquid transfers the heat produced by the power semiconductors and other components. The temperature rise of the coolant during the circulation is typically less than 7 °C (13 °F) for INU modules and less than 10 °C (18 °F) for AFE modules. Typically, 95% of the power losses are dissipated in the coolant. It is recommended to equip the cooling circulation with temperature supervision.

6.4 Cooling System

6.4.1 Cooling Connection of the L Filter

Do not connect the system modules in series. Connecting in series requires high flow rates and high pressure because of the temperature rise of the coolant in the system modules.

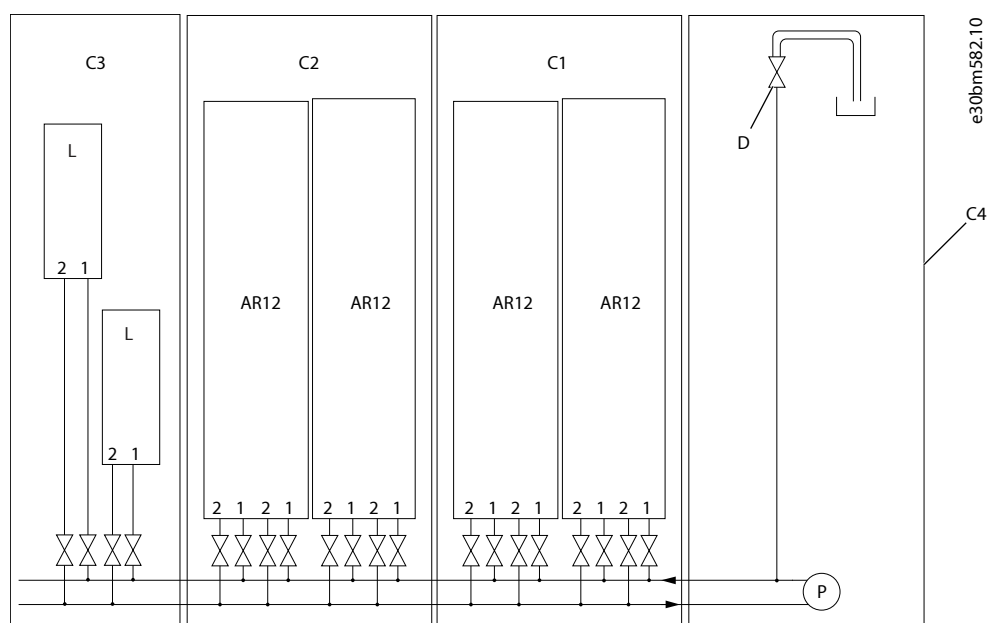
Figure 30: L Filter Cooling Connection Example, 4 x AR12L and 2 x L Filter 1640 A

1	Inlet	2	Outlet
C1	First cabinet section	C2	Second cabinet section
C3	Third cabinet section	C4	Cooling module
L	L filter	D	De-airing valve
P	Pump		

6.4.2 Materials

NOTICE

DAMAGE TO THE SYSTEM FROM INCORRECT MATERIALS

Using steel, copper, or copper alloy pipes or parts in contact with the coolant damages the system.

- Do not use pipes or parts made of steel, copper, or alloys that include copper. If metallic pipes are used in the cooling system, use aluminum or stainless steel pipes. Use AISI316 for steel, and, for example, EN-AW6060, EN-AW6063, or EN-AW6082 for aluminum.

Allowed materials in the cooling system

If they are compatible with the coolant, these materials are allowed in the cooling system:

- Aluminum
- Stainless steel AISI 304/316
- Plastic*
- Elastomers (EPDM, NBR, FDM)*

* If plastic or elastomers are used, check material compatibility within the temperature range of the coolant. See [10.8 Technical Data](#).

Do not use PVC, copper, brass, steel, or other materials not compatible with the heat sink material or coolant.

Recommended material for plastic pipes

- PA11
- PA12
- PEX with oxygen barrier
- PEX-AL-PEX

6.4.3 Heat Exchanger

The heat exchanging equipment can be located outside the electrical room in which the drives are. The connections between these 2 are made on site. To minimize the pressure drops, the piping must be made as short and straight as possible. It is also recommended to install a regulating valve that is equipped with a flow rate measurement point. This makes it possible to measure and regulate the coolant circulation in the commissioning phase.

The highest point of the piping must be equipped with either an automatic or a manual venting device. The material of the piping must comply with at least AISI 304 (and AISI 316 is recommended). Before connecting the pipes, clean the bores thoroughly. If cleaning with water is not possible, use pressured air to remove all loose particles and dust.

6.4.4 Flow Rate of the Coolant

Table 11: Flow Rate Definitions

Flow rate	Definition
Minimum flow rate [l/min]	The minimum flow rate to ensure the complete venting of the cooling system
Nominal flow rate with water [l/min]	The flow rate at nominal power with the coolant temperature of 45 °C (113 °F)
Maximum flow rate [l/min]	If the flow rate exceeds this value, the risk of the cooling system erosion increases.

The coolant flow rates with water are listed in the following tables. To calculate the coolant flow for water-glycol mixture, check the flow rate with water and multiply it with the water-glycol mixture correction factor from [Table 15](#).

Table 12: Flow Rate in Liquid-cooled System Modules and Integrated Filters with Water

Product type	Frame	Minimum flow rate	Flow rate 35 °C (95 °F)	Flow rate 40 °C (104 °F)	Nominal flow rate 45 °C (113 °F)	Maximum flow rate	Liquid volume per element
		[l/min]	[l/min]	[l/min]	[l/min]	[l/min]	[l]
GC/AFE/INU/BCU module	IM10L	7.7	7.7	9.5	11	18	0.55
GC/AFE/INU/BCU module	IM12L	15.4	15.4	18.7	22	36	1.10
AFE/GC with LC Filter (+AEZ1)	AR10L	13	13	16	19	30.4	1.70
AFE/GC with LC Filter (+AEZ1)	AR12L	24	24	29	34	54.4	3.25
INU with dU/dt Filter (+AEU1)	IR10L	18	18	22	25.5	40.8	1.68
INU with dU/dt and CM Filter (+AEU1, +AEU2)	IR10L	18	18	22	25.5	40.8	1.68
INU without filters (+AE10, +AE01)	IR10L	8.5	8.5	10.3	12.2	19.5	1.50
INU with dU/dt Filter (+AEU1)	IR12L	26	26	32	37	59.2	3.34
INU without filters (+AE10)	IR12L	18	18	21	25	40	3.00
INU with sine-wave filter (+AES1)	IR12L	24	24	29	34	54.4	3.25
DC/DC converter with DC Filter (+AED1)	DR10L	12.5	12.5	15	17.7	28.3	1.70
DC/DC converter with DC Filter (+AED1)	DR12L	24	24	29	34	54.4	3.25

Table 13: Flow Rate in Liquid-cooled Input and Output Filters with Water

Product type	Current at 690 V AC	Minimum flow rate	Flow rate 35 °C (95 °F)	Flow rate 40 °C (104 °F)	Nominal flow rate 45 °C (113 °F)	Maximum flow rate	Liquid volume per element
	[A]	[l/min]	[l/min]	[l/min]	[l/min]	[l/min]	[l]
LC Filter for AFE/GC OF7Z1	380	5.5	5.5	6.7	8.0	12.8	0.70
LC Filter for AFE/GC OF7Z1	760	8.0	8.0	9.5	11	17.6	1.25
LCL Filter for AFE/GC OF7Z3	400	10.5	10.5	13	15.5	24.8	0.90
LCL Filter for AFE/GC OF7Z3	800	13	13	15.8	18.5	29.6	1.25
L Filter OF7Z5	400	5.0	5.0	6.3	7.5	12	0.20
L Filter OF7Z5	1000	5.0	5.0	6.3	7.5	12	0.20
L Filter OF7Z5	1640	5.5	5.5	7.0	8.5	13.6	0.60
L Filter OF7Z5	2300	10	10	13	15	25	0.65
dU/dt Filter OF7U1	416	13	13	16	18.5	29.6	0.68

Table 13: Flow Rate in Liquid-cooled Input and Output Filters with Water - (continued)

Product type	Current at 690 V AC	Minimum flow rate	Flow rate 35 °C (95 °F)	Flow rate 40 °C (104 °F)	Nominal flow rate 45 °C (113 °F)	Maximum flow rate	Liquid volume per element
	[A]	[l/min]	[l/min]	[l/min]	[l/min]	[l/min]	[l]
dU/dt Filter OF7U1	820	14	14	17.5	20.5	32.8	1.34
dU/dt and CM Filter OF7U2	416	13	13	16	18.5	29.6	0.68
Sine-wave Filter OF7S1SM	800	8.0	8.0	9.5	11	17.6	1.25
DC Filter OF7D1	570	5.5	5.5	6.7	6.7	10.7	0.70
DC Filter OF7D1	1200	8.0	8.0	9.5	11	17.6	1.25

Table 14: Flow Rates in the Filter Components (SISO Filter)

Product type	Current at 690 V AC	Minimum flow rate	Flow rate 35 °C (95 °F)	Flow rate 40 °C (104 °F)	Nominal flow rate 45 °C (113 °F)	Maximum flow rate	Liquid volume per element
	[A]	[l/min]	[l/min]	[l/min]	[l/min]	[l/min]	[l]
LC filter for OF7SI2/OF7SI4	380	5.5	5.5	6.7	8.0	12.8	0.70
LC filter for OF7SI2/OF7SI4	760	8.0	8.0	9.5	11	17.6	1.25
L filter for OF7SI4	400	5.0	5.0	6.3	7.5	12	0.20
L filter for OF7SI4	1000	5.0	5.0	6.3	7.5	12	0.20
L filter for OF7SI4	1640	5.5	5.5	7.0	8.5	13.6	0.60
Sine-wave filter for OF7SO2	800	8.0	8.0	9.5	11	17.6	1.25
Reactor for OF7SI2/OF7SI4/OF7SO2	380	4.0	5.0	5.0	6.0	12.8	0.43
Reactor for OF7SI2/OF7SI4/OF7SO2	760	4.0	5.0	5.0	6.0	12.8	0.45
Reactor for OF7SI2/OF7SI4/OF7SO2	1500	4.0	5.0	5.0	6.0	12.8	0.53

Table 15: Correction Factors when Using a Water-glycol Mixture

Mixture	Correction factor
30% water-glycol mixture	1.18
50% water-glycol mixture	1.3

6.4.4.1 Flow Rates in Parallel Power Units

In system modules with 2 parallel power units and a filter (IR12L/AR12L/DR12L), the flow rate of the coolant is not divided equally between cooling channels 1 and 2. The difference in flow rate between the cooling channels is significant, but normal behavior. There is a difference in flow rate, because the filter is connected to the inlet of channel 2 and outlet of channel 1.

The following tables show coolant flow rates measured from the inlet channels of IR12L and AR12L modules.

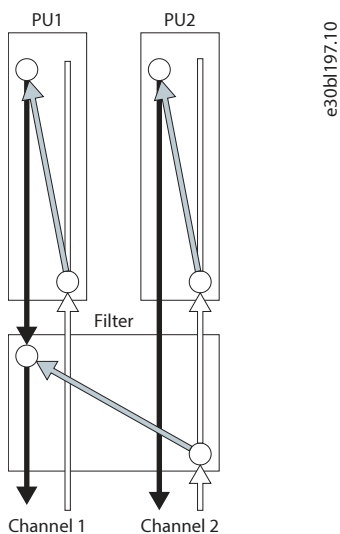

Figure 31: Coolant Flow in Parallel Power Units

Table 16: Examples of Measured Coolant Flow Rates of IR12L

Channel 1 flow rate (l/min)	Channel 2 flow rate (l/min)	Total flow rate (l/min)
11.6	25.2	36.8
14.7	32.4	47.1
17.4	38.3	55.7
18.2	40.2	58.4

Table 17: Examples of Measured Coolant Flow Rates of AR12L

Channel 1 flow rate (l/min)	Channel 2 flow rate (l/min)	Total flow rate (l/min)
12.8	21	33.8
16.4	26.8	43.2
19.3	31.7	51
20.2	33.1	53.3

6.4.5 Volume of the Pipe

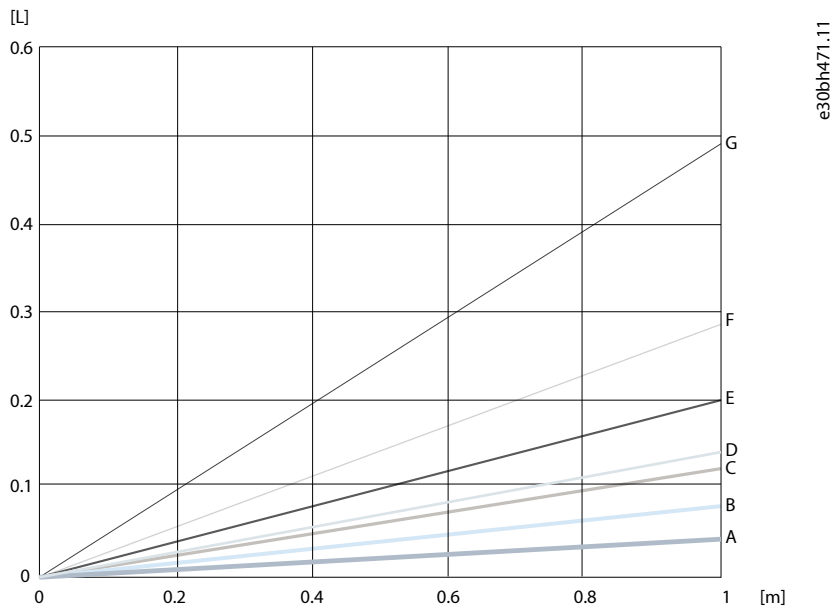

e30bh471.11

A	8 mm	B	10 mm
C	12 mm	D	13 mm
E	16 mm	F	19 mm
G	25 mm		

Figure 32: Volume of the Pipe with Different Inside Diameters, 8–25 mm

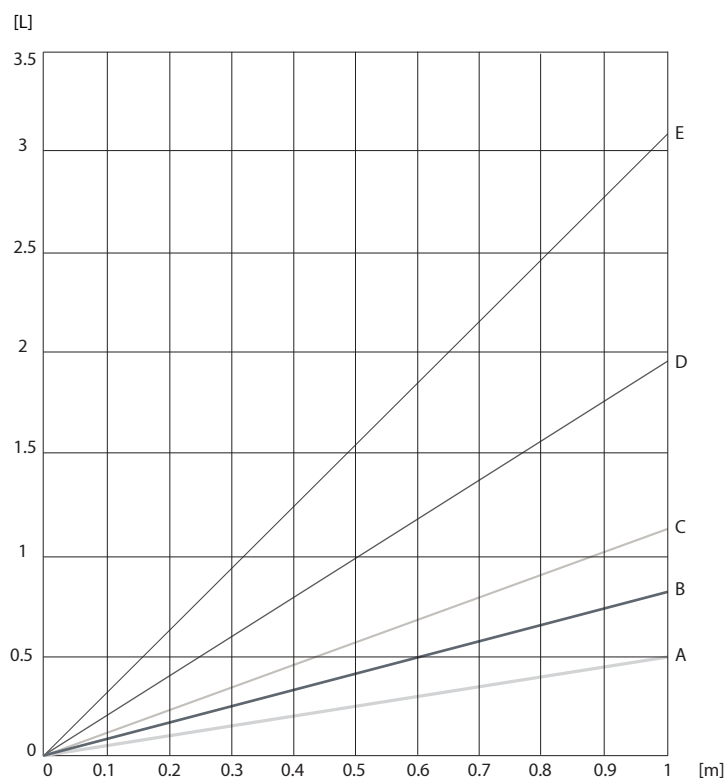

e30bh472.11

A	25 mm	B	32 mm
C	38 mm	D	50 mm
E	63 mm		

Figure 33: Volume of the Pipe with Different Inside Diameters, 25–63 mm

6.4.6 Pressure Drop

6.4.6.1 Pressure Drop and Correction Factors

The pressure drop with 20 °C (68 °F) water was calculated with a 13 mm (0.5 in) pipe of 1 m (3.3 ft) length at inlet and outlet.

The pressure drop with 48 °C (118 °F) antifreeze can be calculated with the help of the graphs by multiplying them by correction factors.

Table 18: Corrections Factors for Pressure Drop with Antifreeze

Antifreeze	Correction factor
Ethylene glycol 10%	1.0
Ethylene glycol 20%	1.0
Ethylene glycol 30%	1.0
Ethylene glycol 40%	1.05
Ethylene glycol 50%	1.1
Propylene glycol 10%	1.0
Propylene glycol 20%	1.0
Propylene glycol 30%	1.05
Propylene glycol 40%	1.1
Propylene glycol 50%	1.2

6.4.6.2 Pressure Drop of IM10L, IM12L, AM10L, AM12L, DM10L, DM12L, BM 10L and BM12L

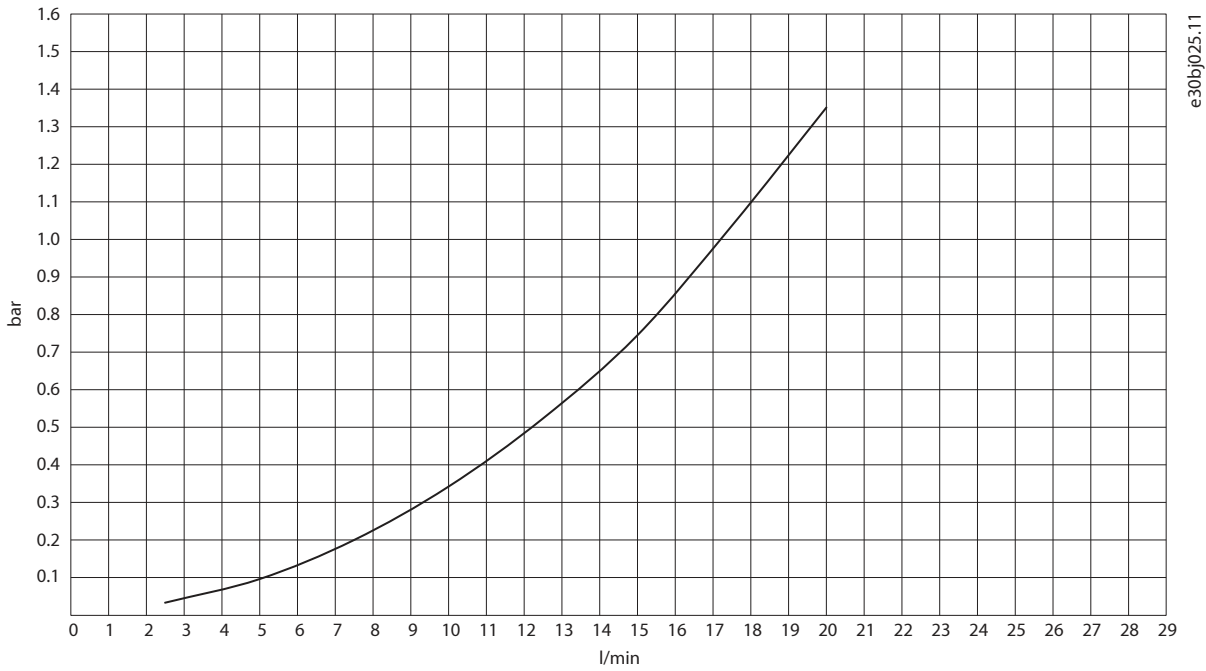

e30bj025.11

Figure 34: Unit Pressure Drop with Water, IM10L/AM10L/DM10L/BM10L

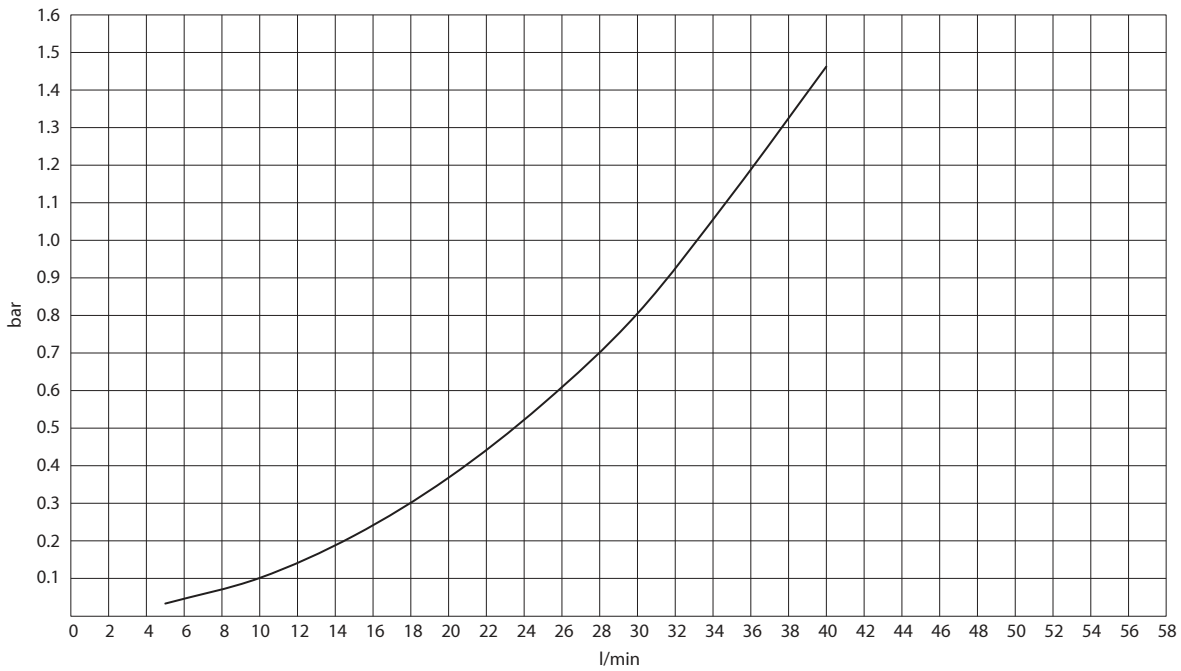

e30bj026.11

Figure 35: Unit Pressure Drop with Water, IM12L/AM12L/DM12L/BM12L

6.4.6.3 Pressure Drop of AR10L, IR10L, and Filters

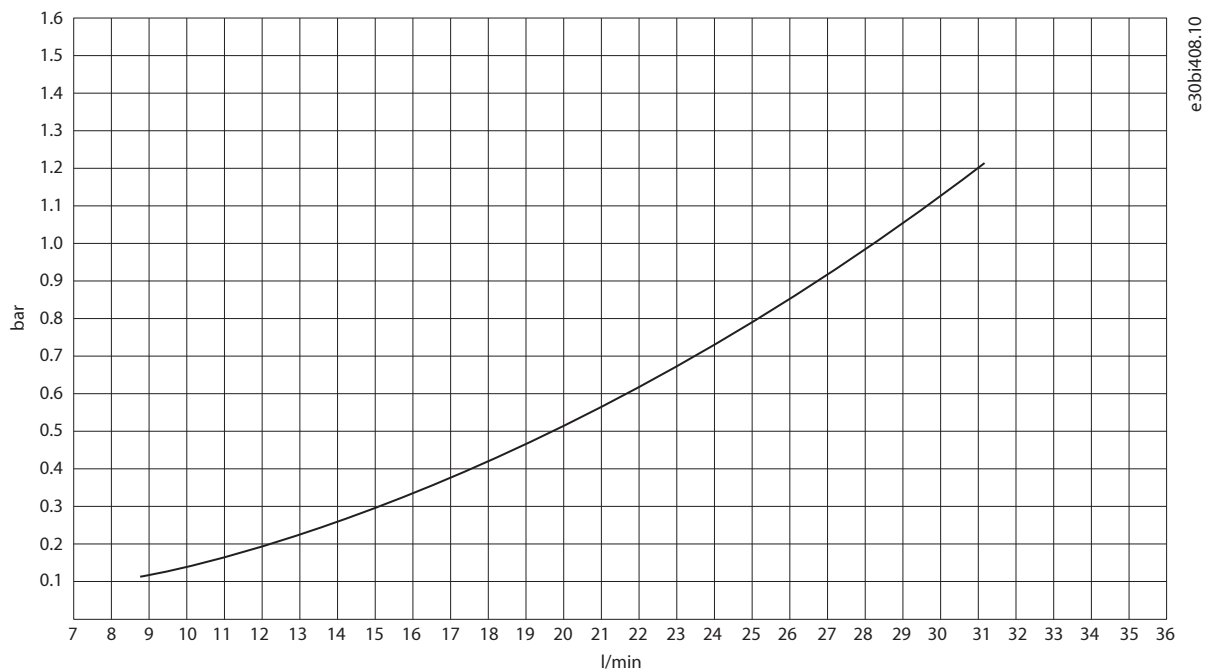

Figure 36: Unit Pressure Drop with Water, AFE AR10L

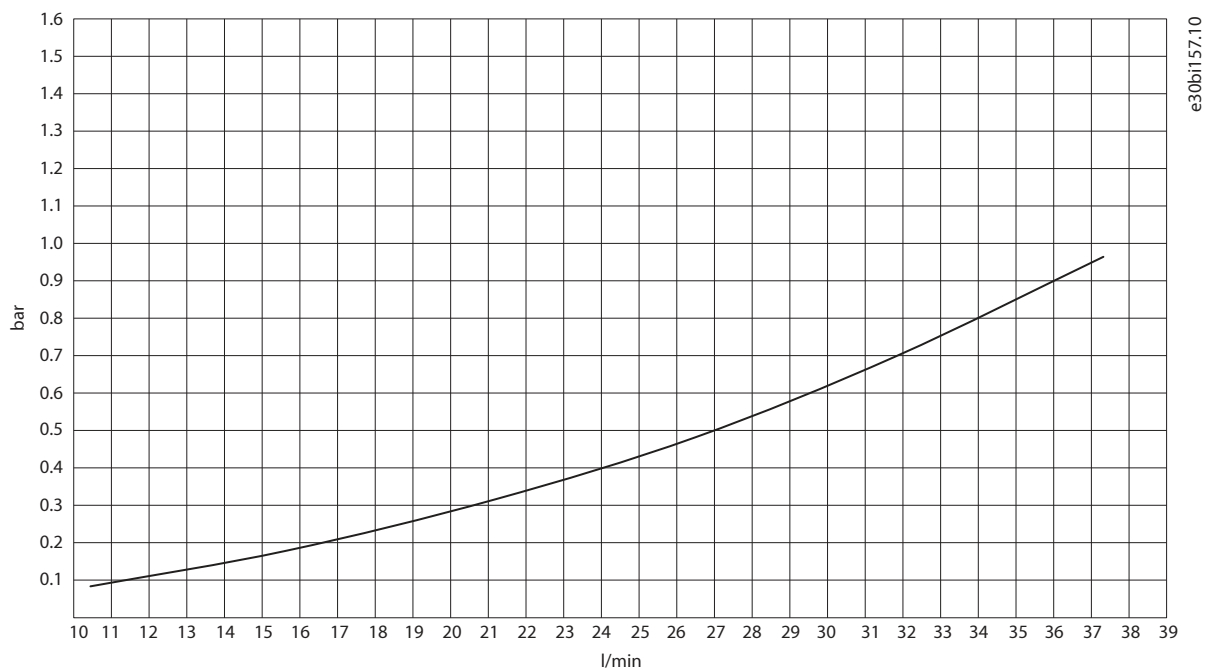

Figure 37: Unit Pressure Drop with Water, IR10L with dU/dt and Common-mode Filter (+AEU1, +AEU2)

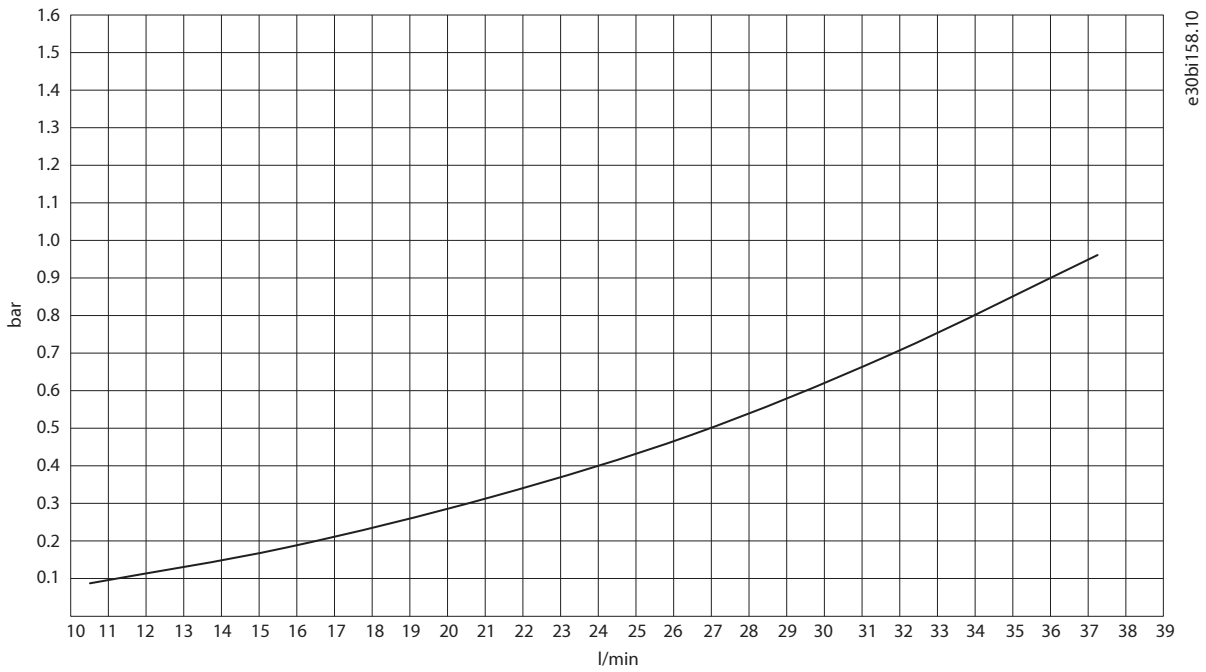

Figure 38: Unit Pressure Drop with Water, IR10L with dU/dt Filter (+AEU1)

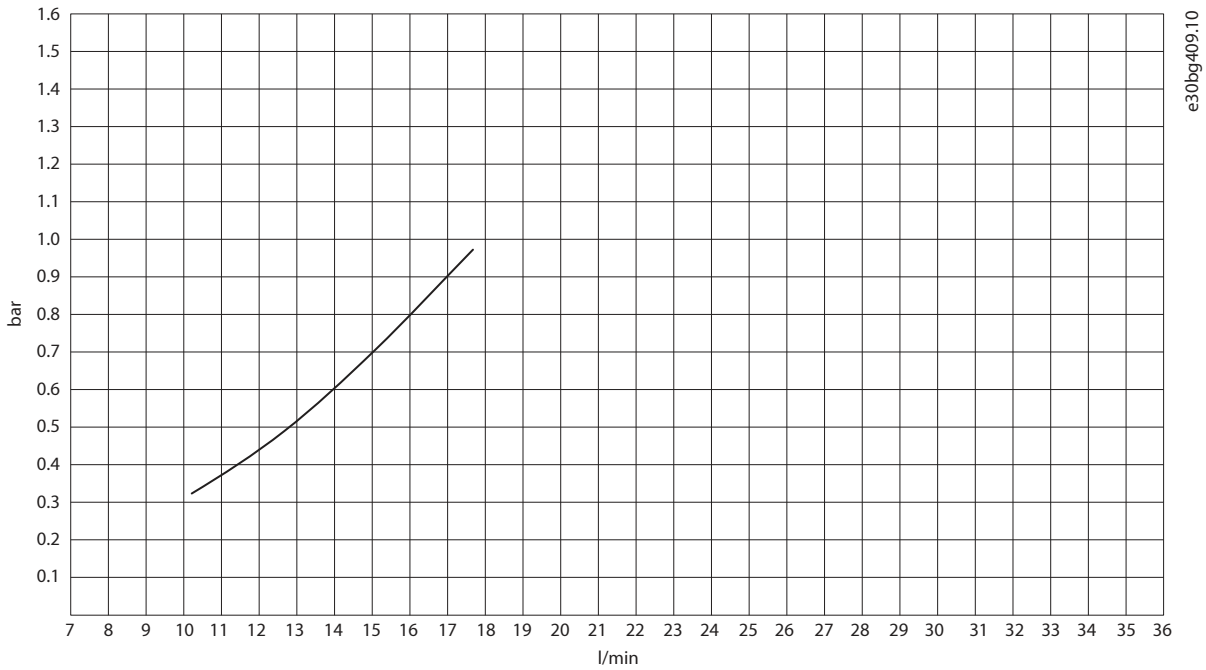

Figure 39: Unit Pressure Drop with Water, INU IR10L without Filters (+AE10)

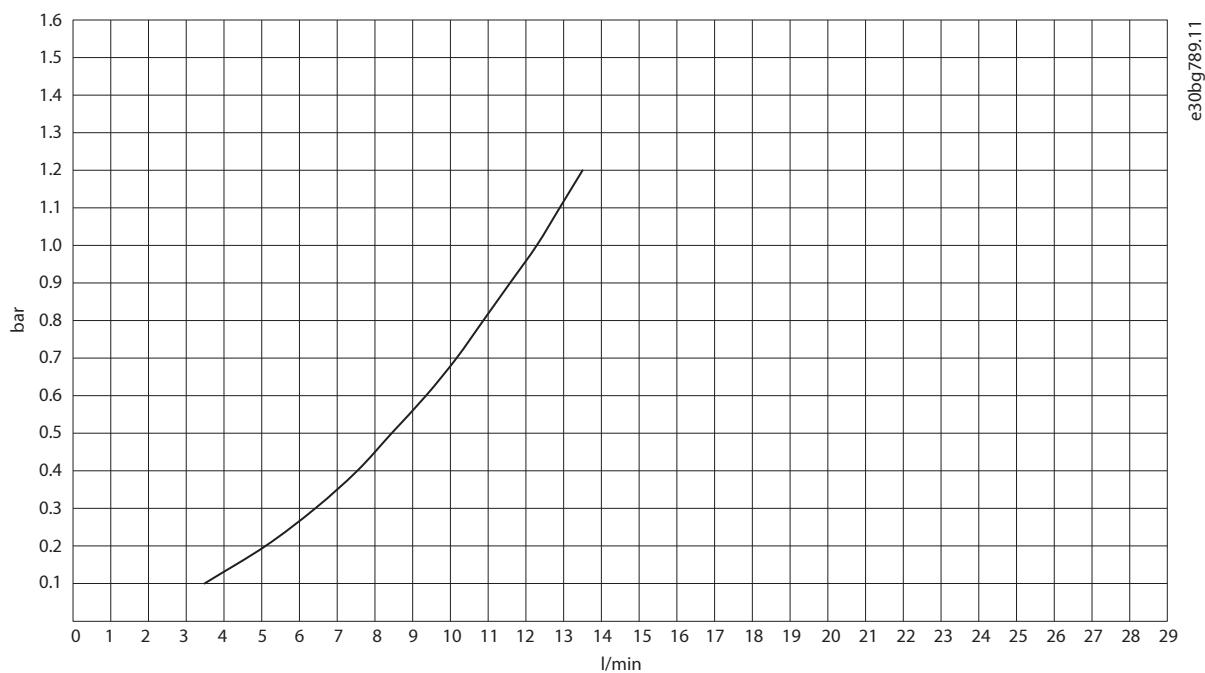

Figure 40: Pressure Drop with Water, LC Filter for AFE OF7Z1 (+AEZ1), 380 A

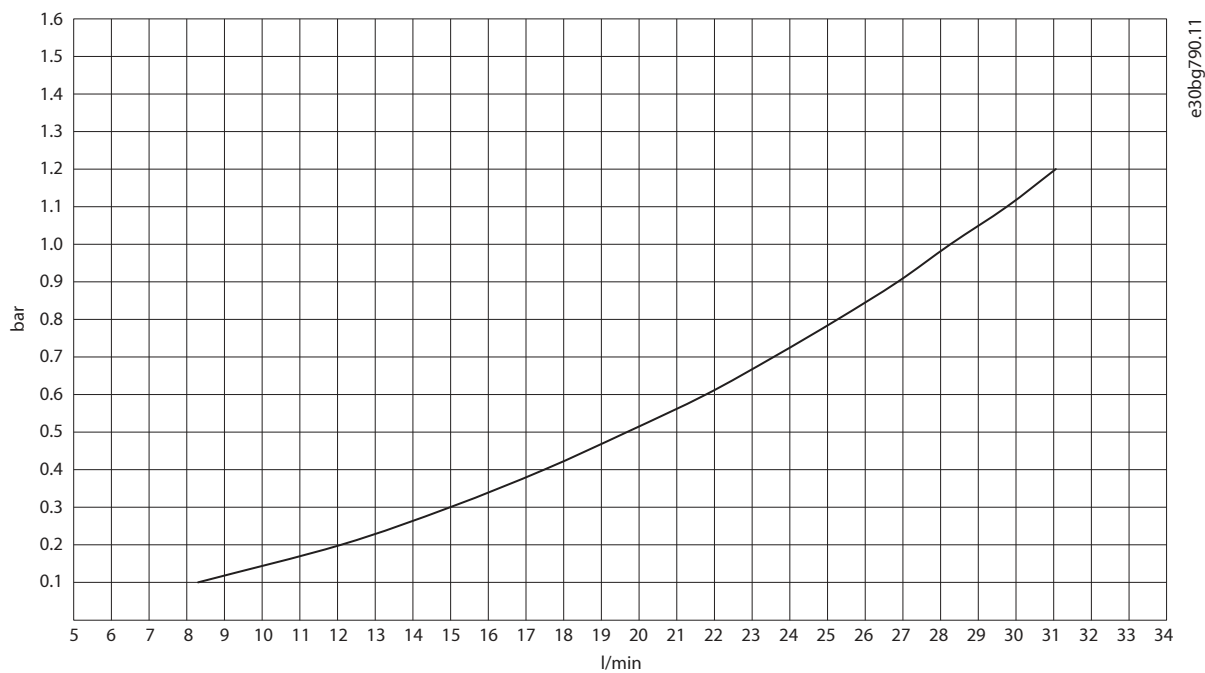
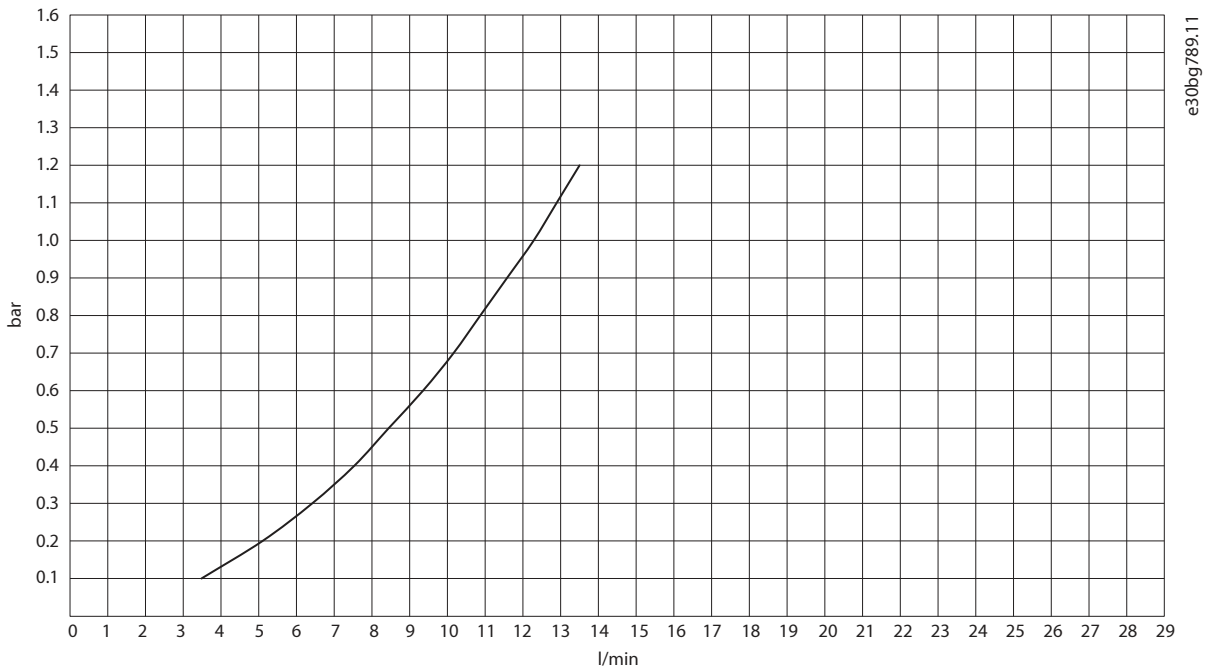
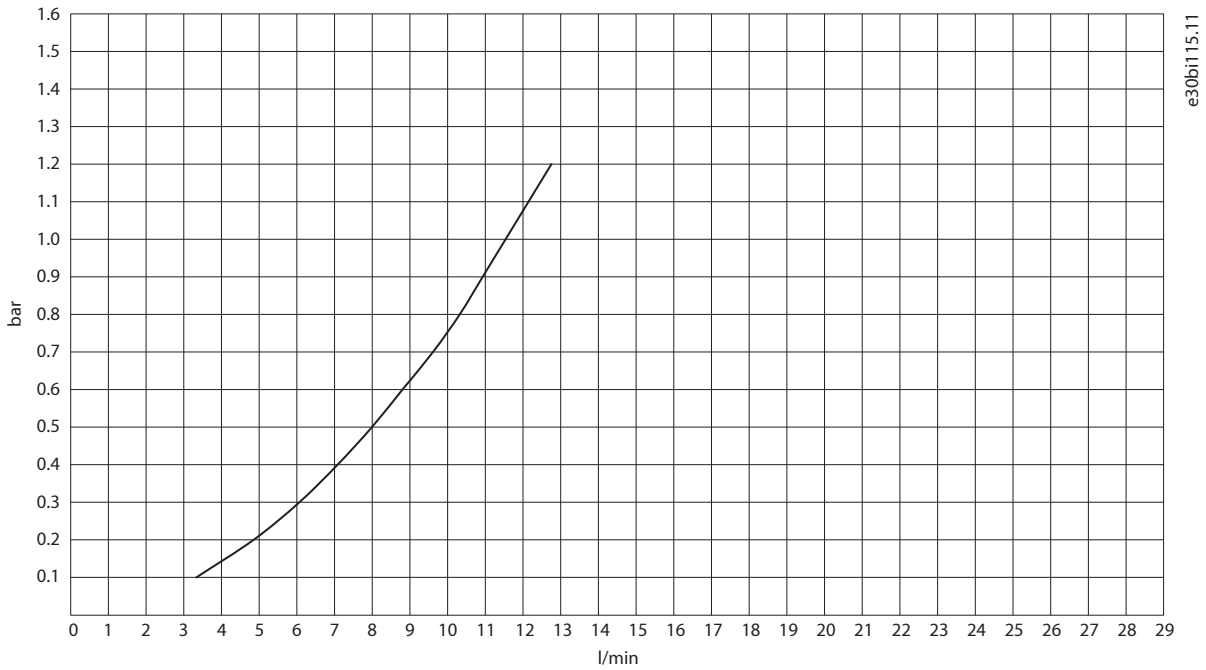

Figure 41: Pressure Drop with Water, dU/dt Filter OF7U1 (+AEU1), 416 A, and dU/dt and CM Filter OF7U2 (+AEU2), 416 A



e30bg789.11

Figure 42: Pressure Drop with Water, LC10L (SISO Filter 10L)



e30bi115.11

Figure 43: Pressure Drop, L Filter 400 A (SISO Filter 10L)

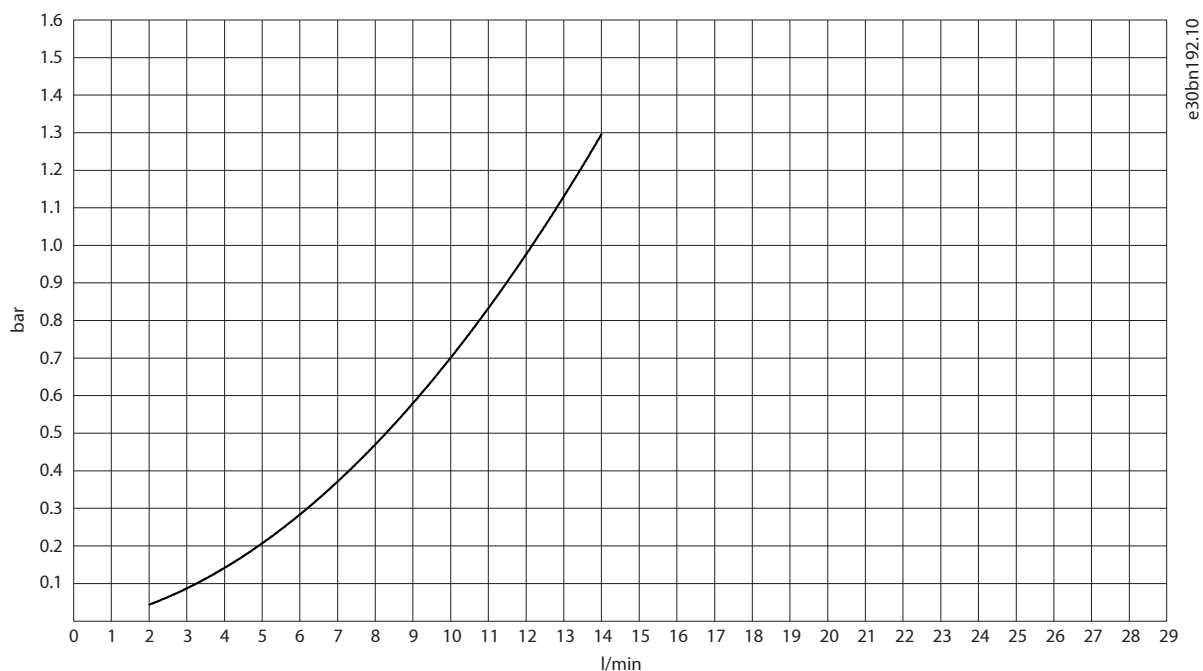

Figure 44: Pressure Drop, Reactor 450/900/1750 A (SISO Filter 10L)

6.4.6.4 Pressure Drop of AR12L, IR12L, and Filters

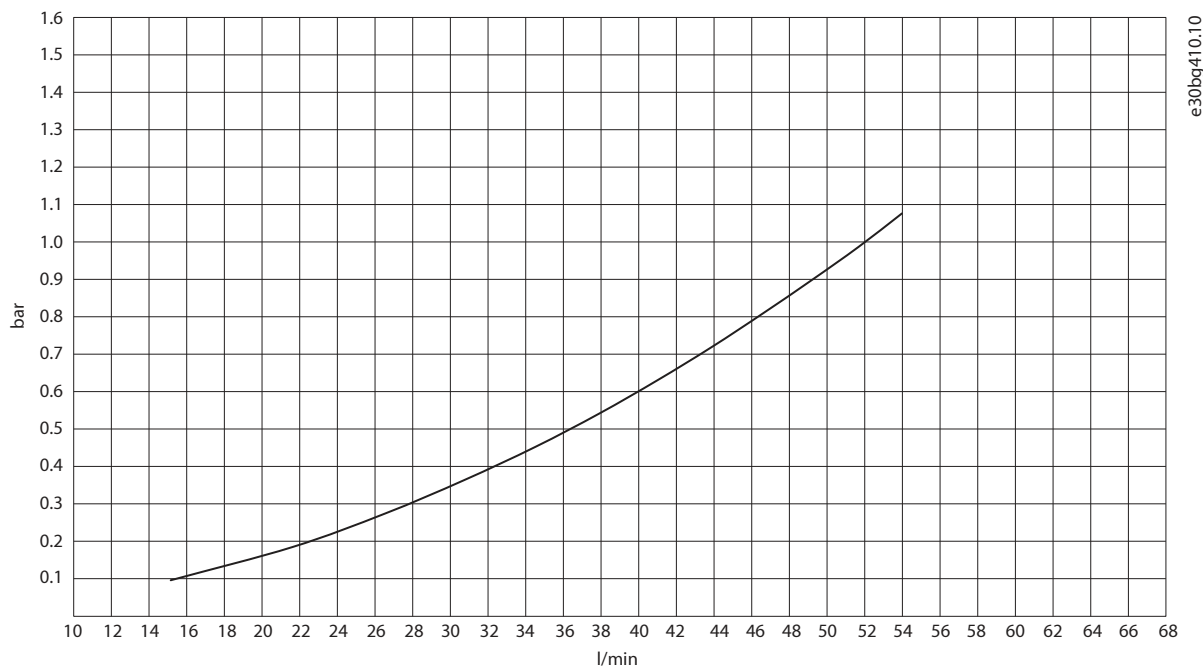

Figure 45: Unit Pressure Drop with Water, AFE AR12L (+AEZ1) and INU IR12L with Sine-wave Filter (+AES1, +AEZ1)

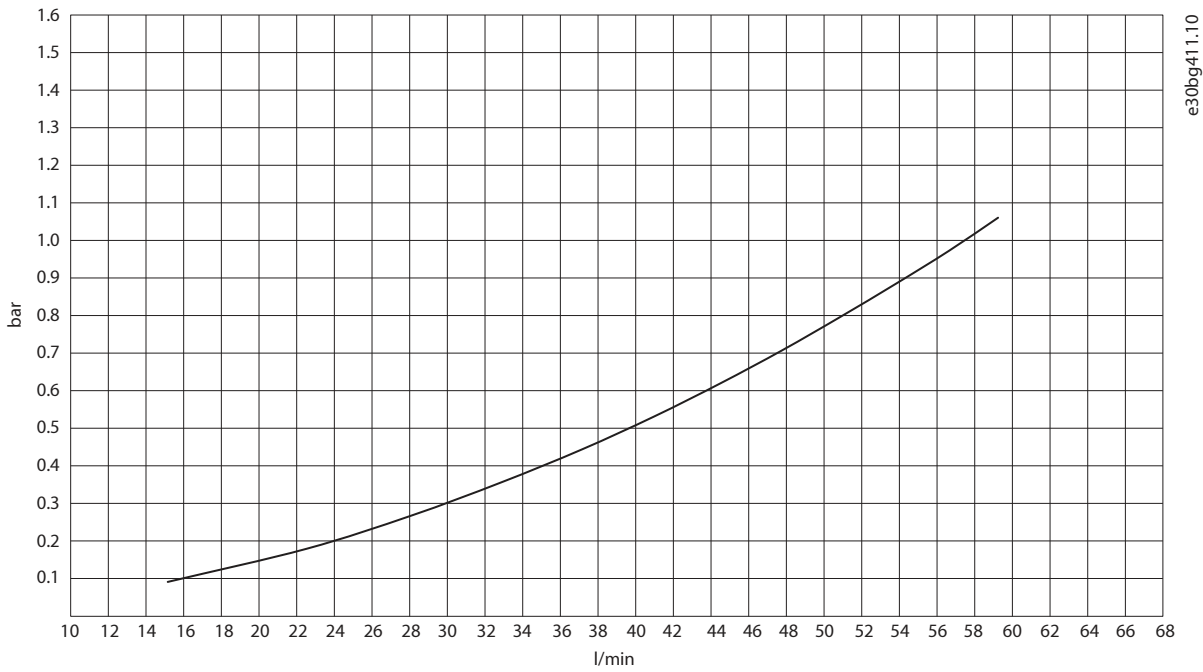

Figure 46: Unit Pressure Drop with Water, INU IR12L with dU/dt Filter (+AEU1)

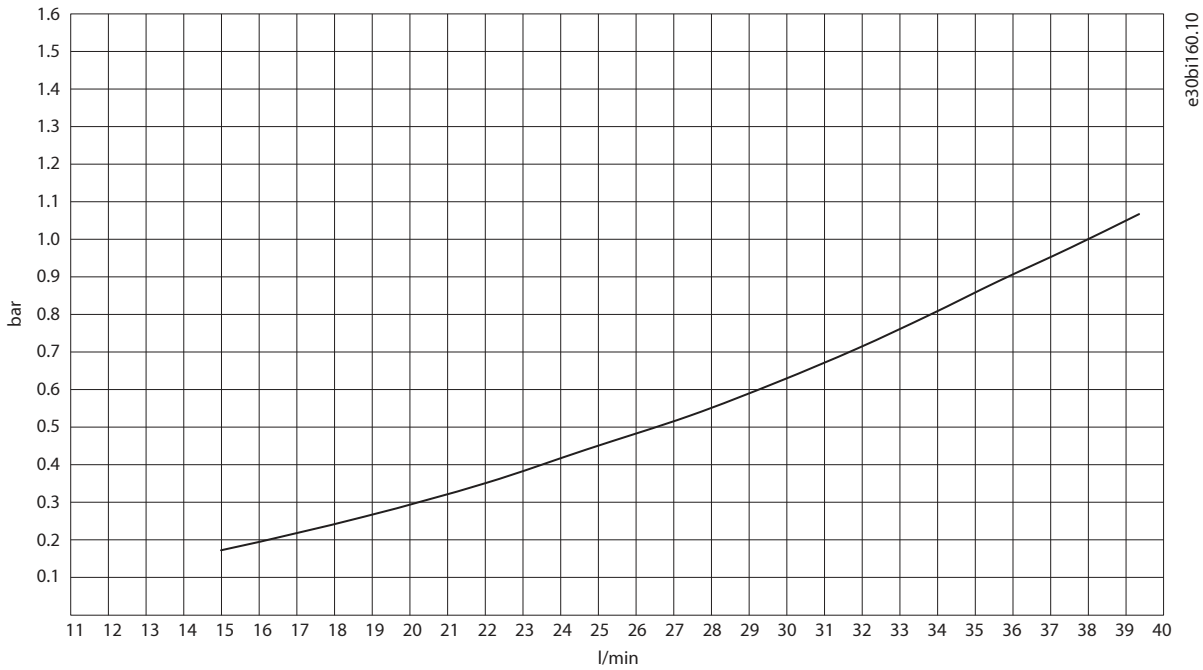

Figure 47: Unit Pressure Drop with Water, INU IR12L without Filters (+AE10)

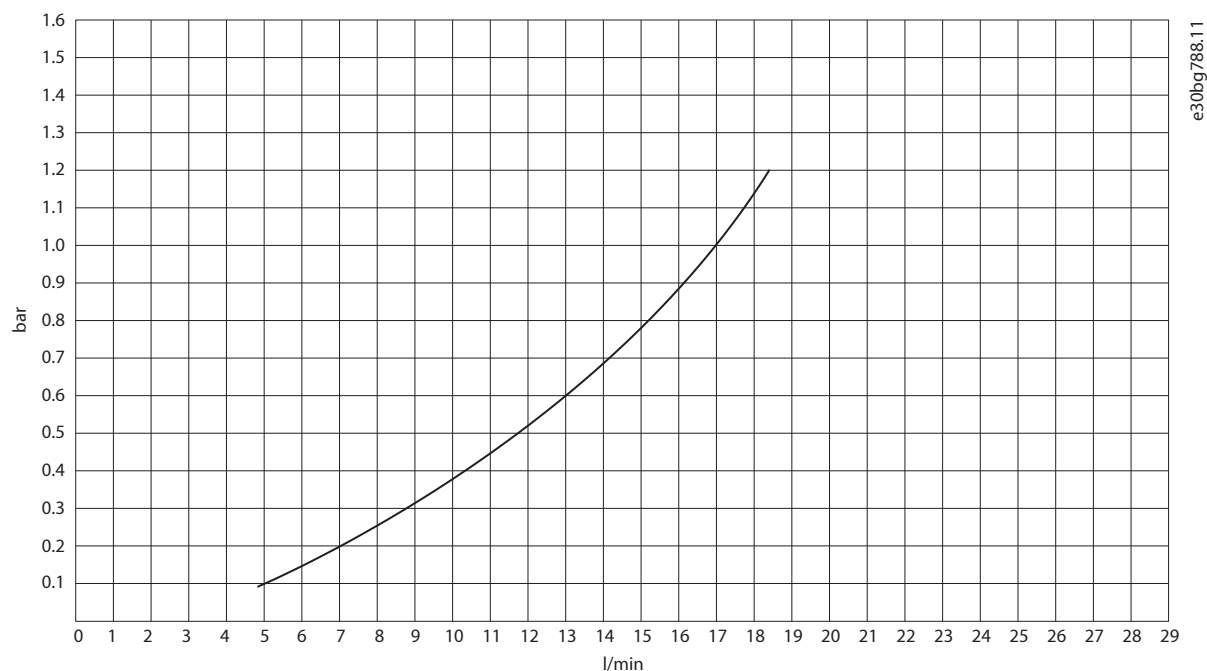

Figure 48: Pressure Drop with Water, LC Filter for AFE OF7Z1 (+AEZ1), 760 A

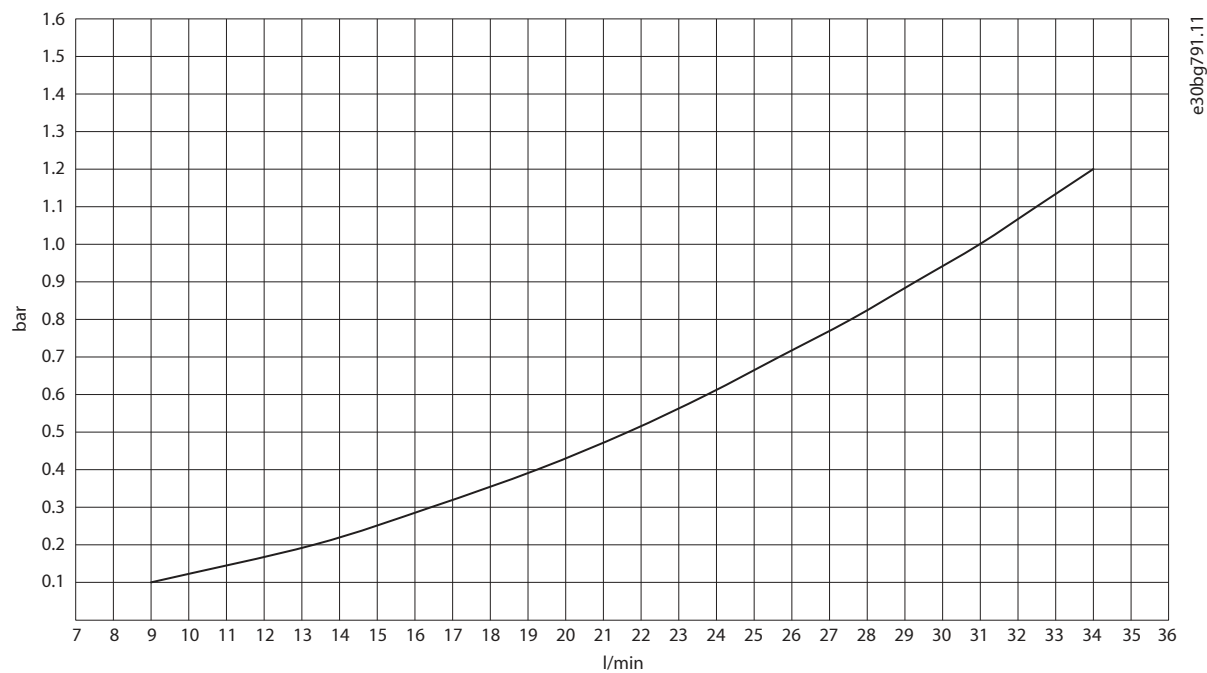

Figure 49: Pressure Drop with Water, dU/dt Filter OF7U1 (+AEU1), 820 A

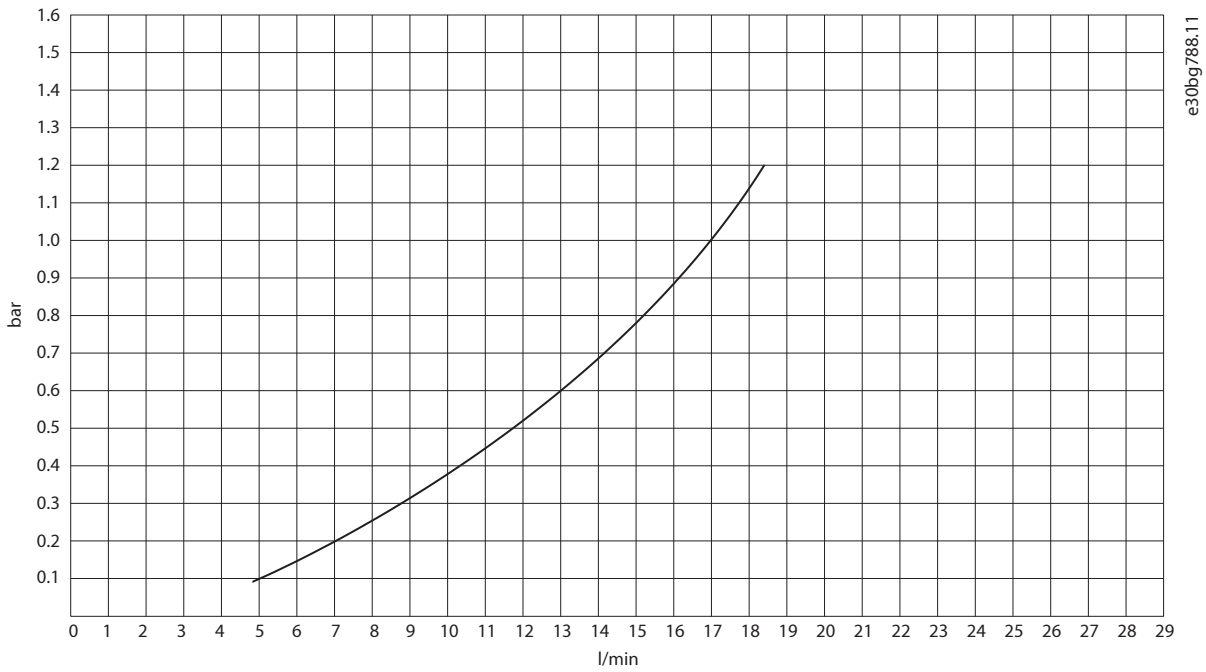

Figure 50: Pressure Drop with Water, Sine-wave Filter OF7S1SM (+AES1), 800 A

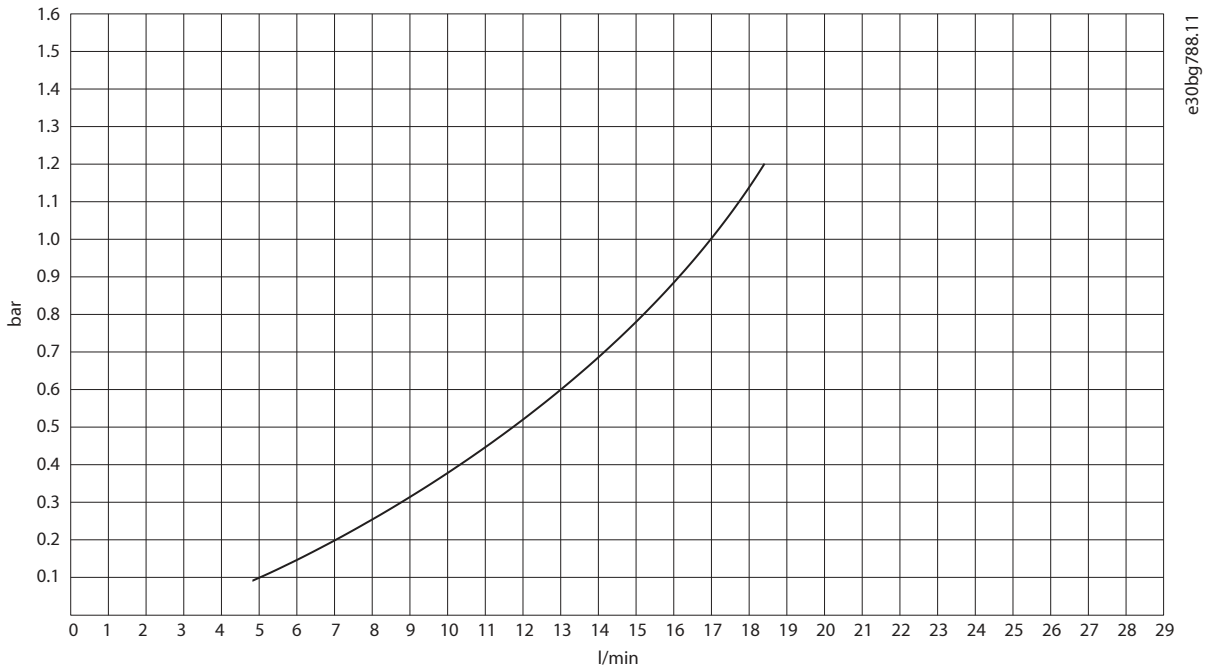

Figure 51: Pressure Drop with Water, LC12L and SIN12L (SISO Filter 12L)

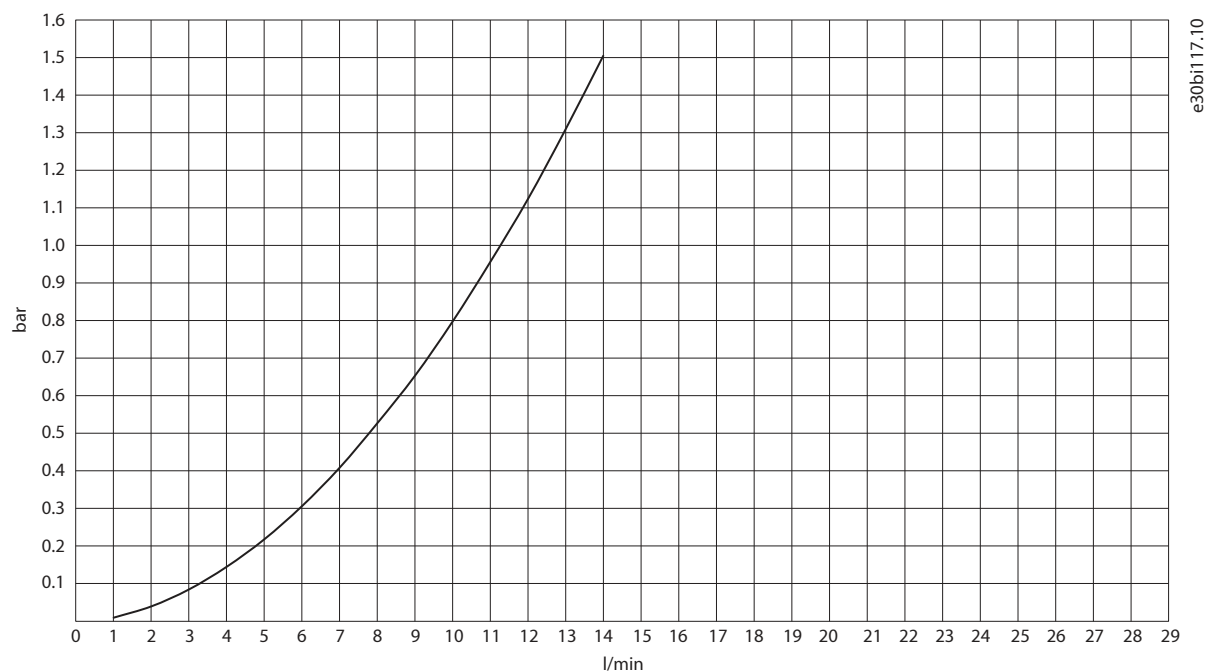

Figure 52: Pressure Drop, L Filter 1000 A (SISO Filter 12L)

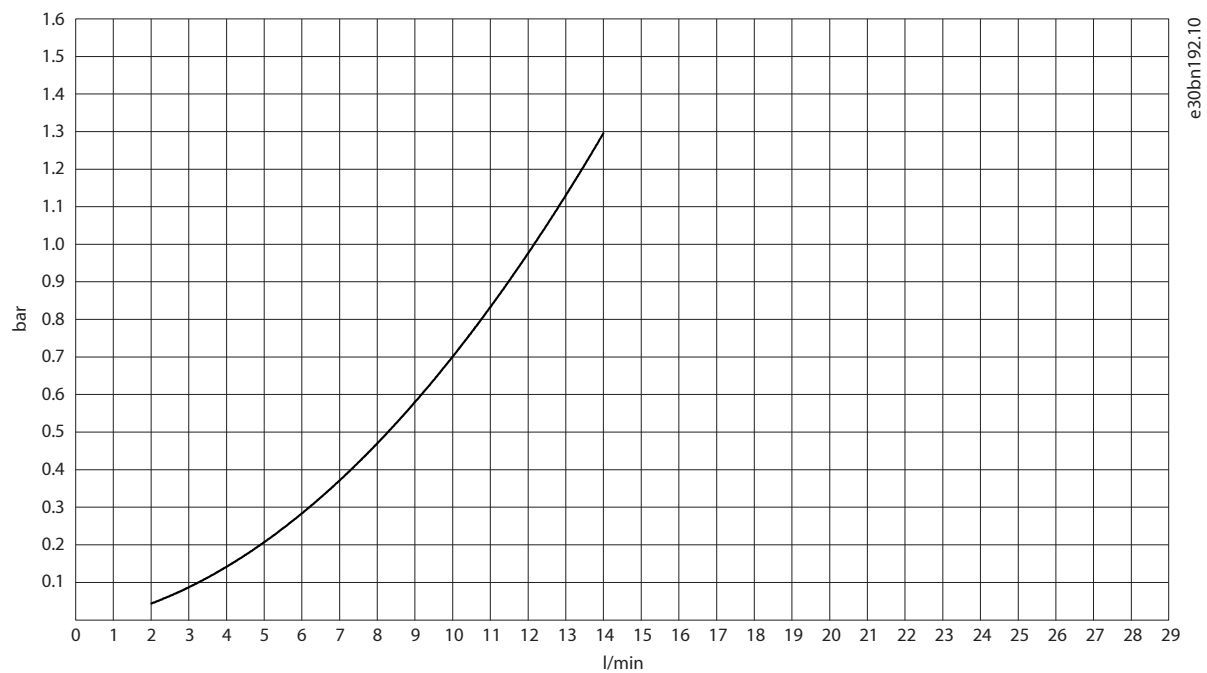

Figure 53: Pressure Drop, Reactor 450/900/1750 A (SISO Filter 12L)

6.4.6.5 Pressure Drop of the Grid-side L Filter

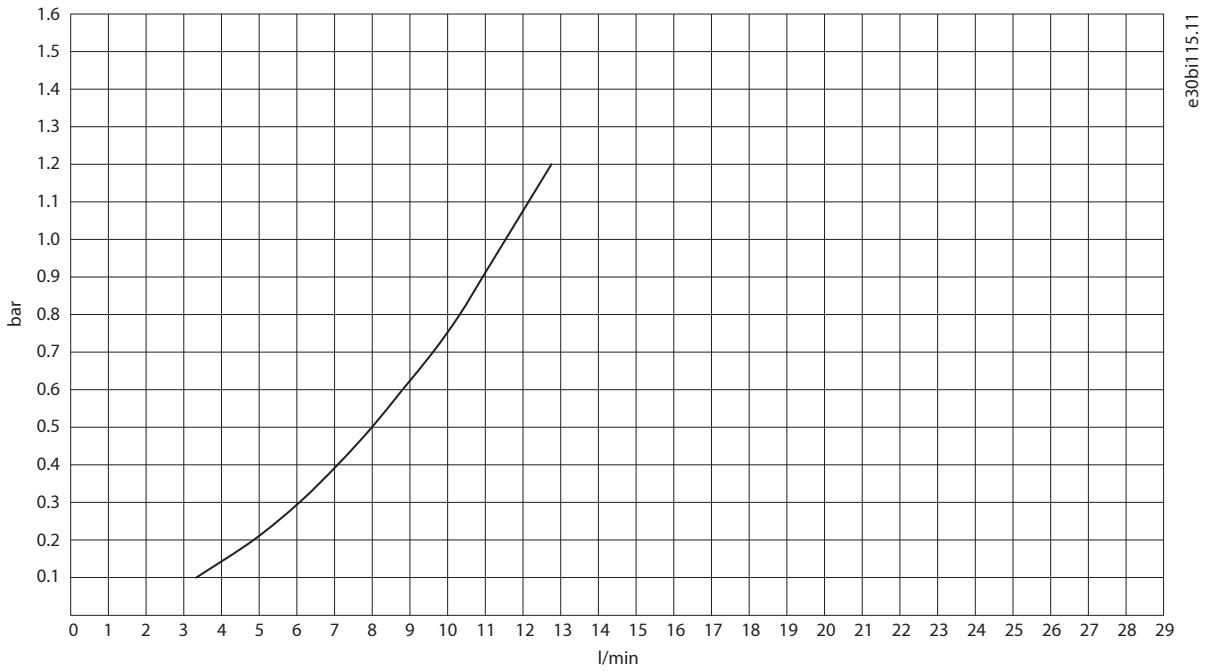

Figure 54: Pressure Drop, Grid-side L Filter OF7Z5, 690 V/400 A

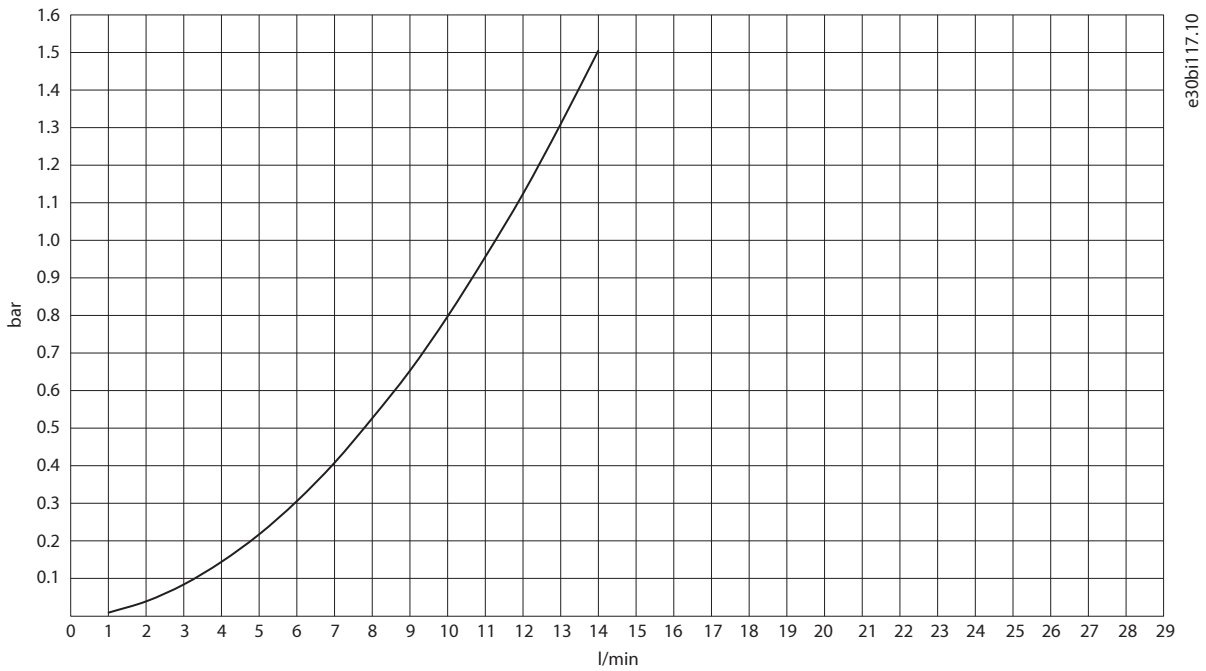

Figure 55: Pressure Drop, Grid-side L Filter OF7Z5, 690 V/1000 A

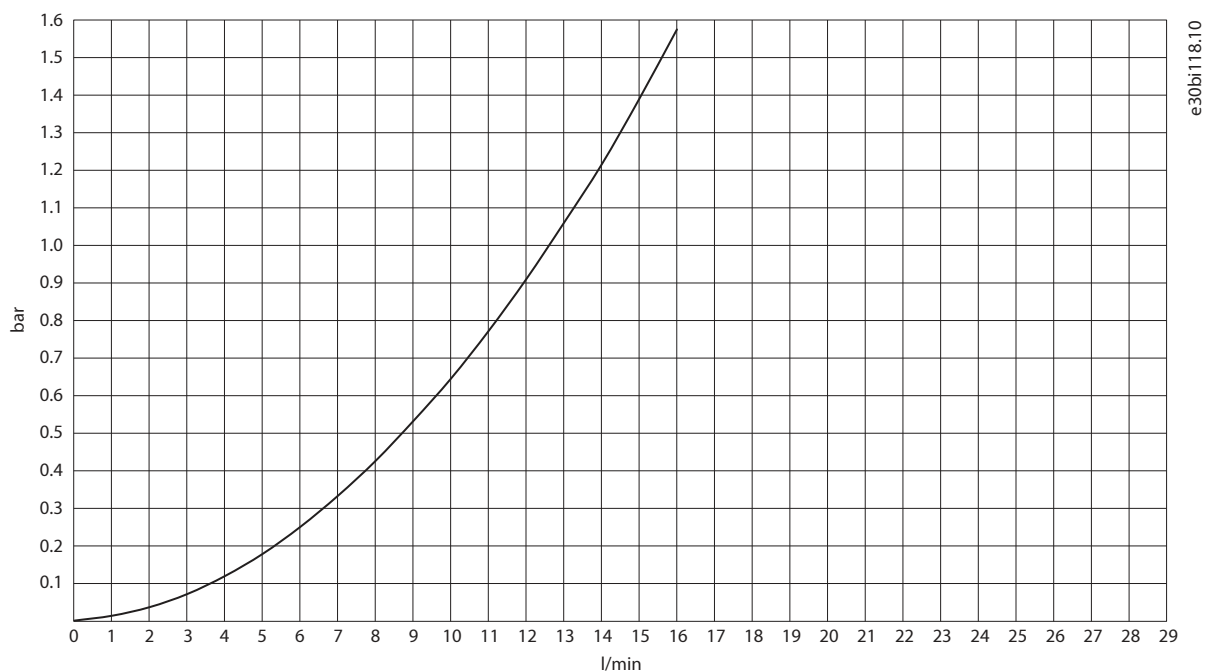

Figure 56: Pressure Drop, Grid-side L Filter OF7Z5, 690 V/1640 A

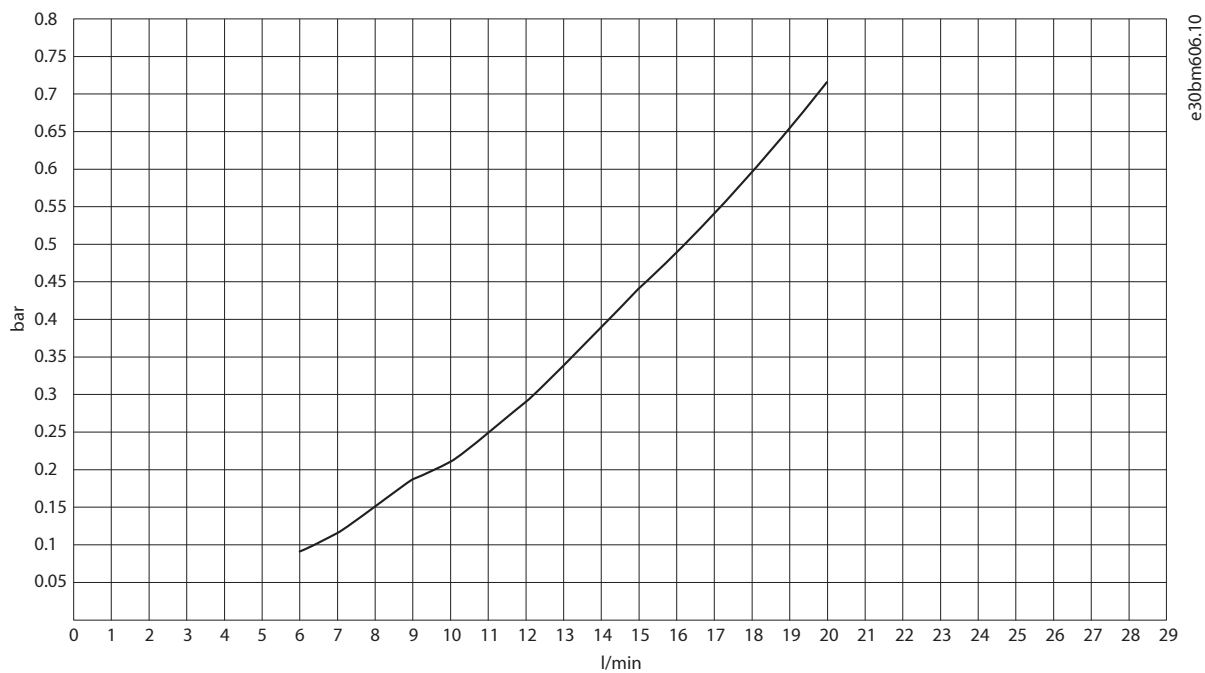

Figure 57: Pressure Drop, Grid-side L Filter OF7Z5, 690 V/2300 A

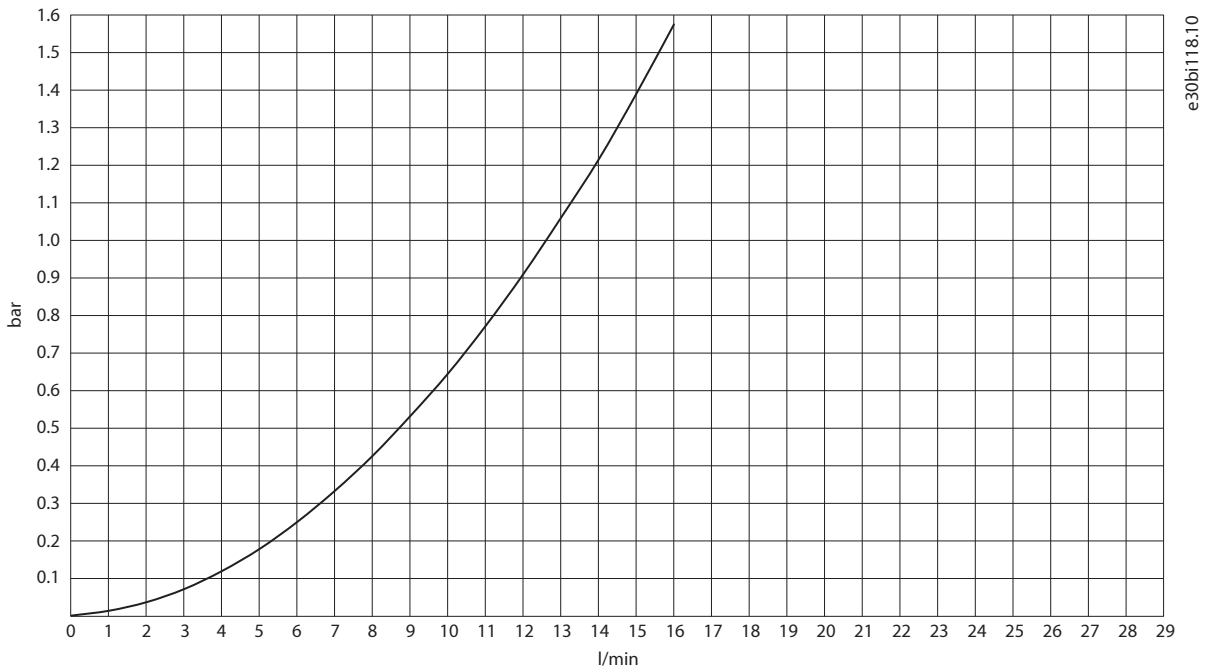

Figure 58: Pressure Drop, L Filter 1640 A (SISO Filter 14L)

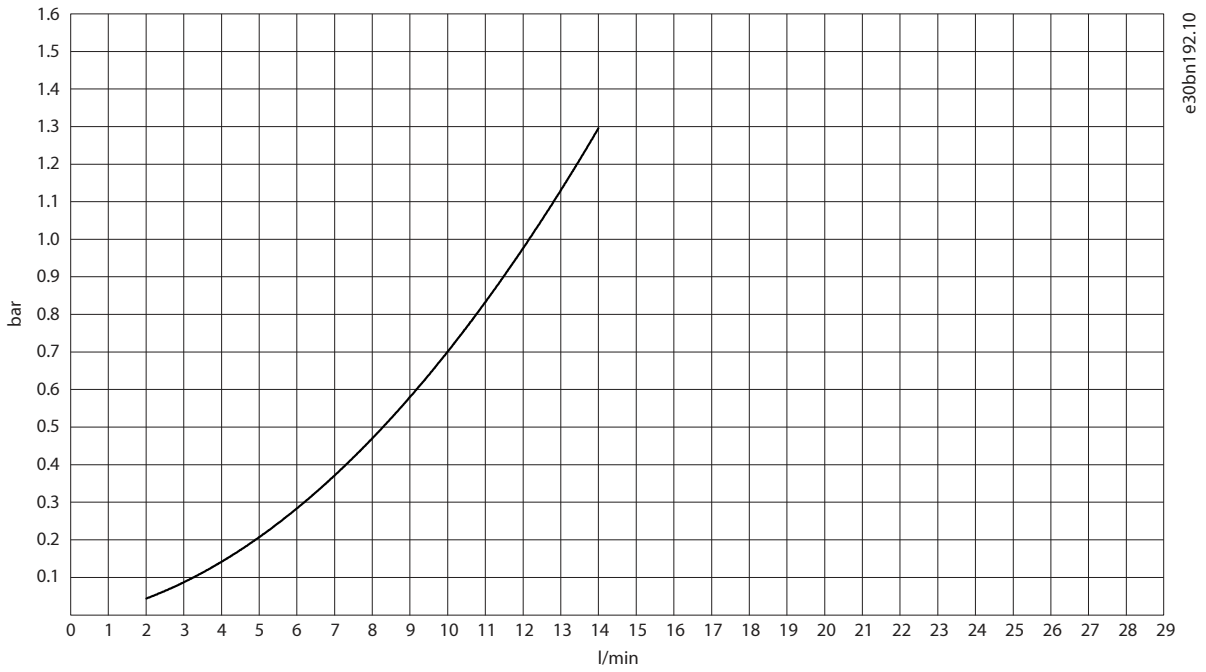

Figure 59: Pressure Drop, Reactor 450/900/1750 A (SISO Filter 14L)

6.4.6.6 Pressure Drop of DR10L, DR12L, and Filters

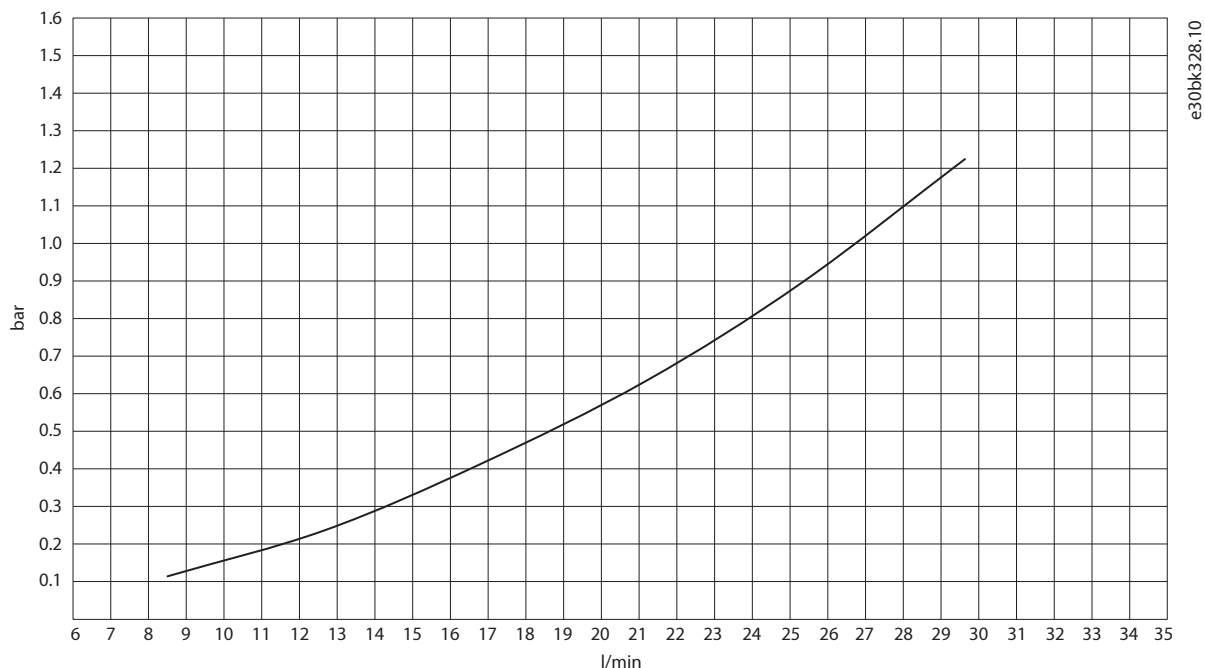

Figure 60: Unit Pressure Drop with Water, DC/DC Converter DR10L with DC Filter (+AED1)

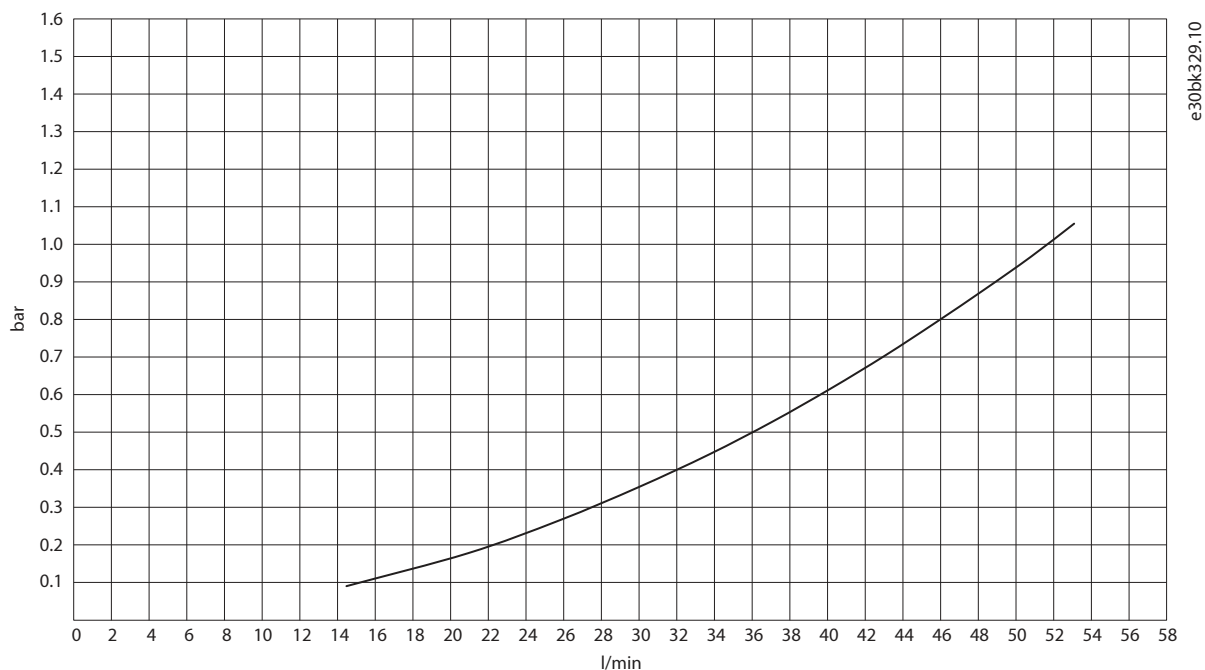

Figure 61: Unit Pressure Drop with Water, DC/DC Converter DR12L with DC Filter (+AED1)

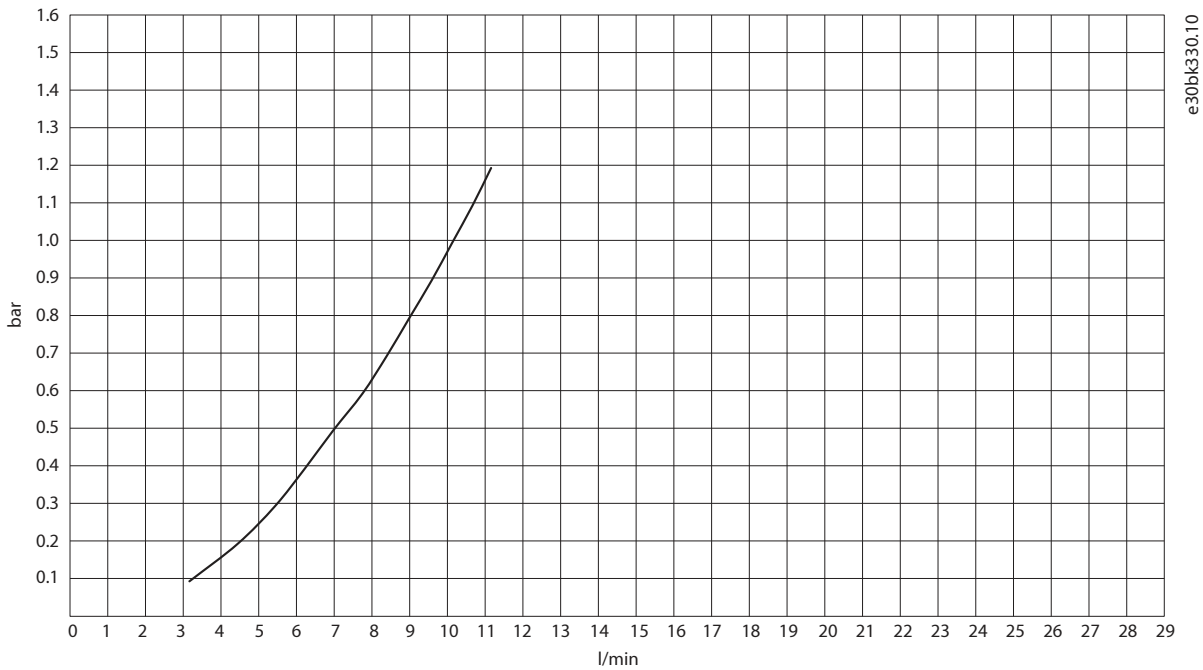

Figure 62: Pressure Drop with Water, DC Filter for DC/DC Converter OF7D1, 570 A

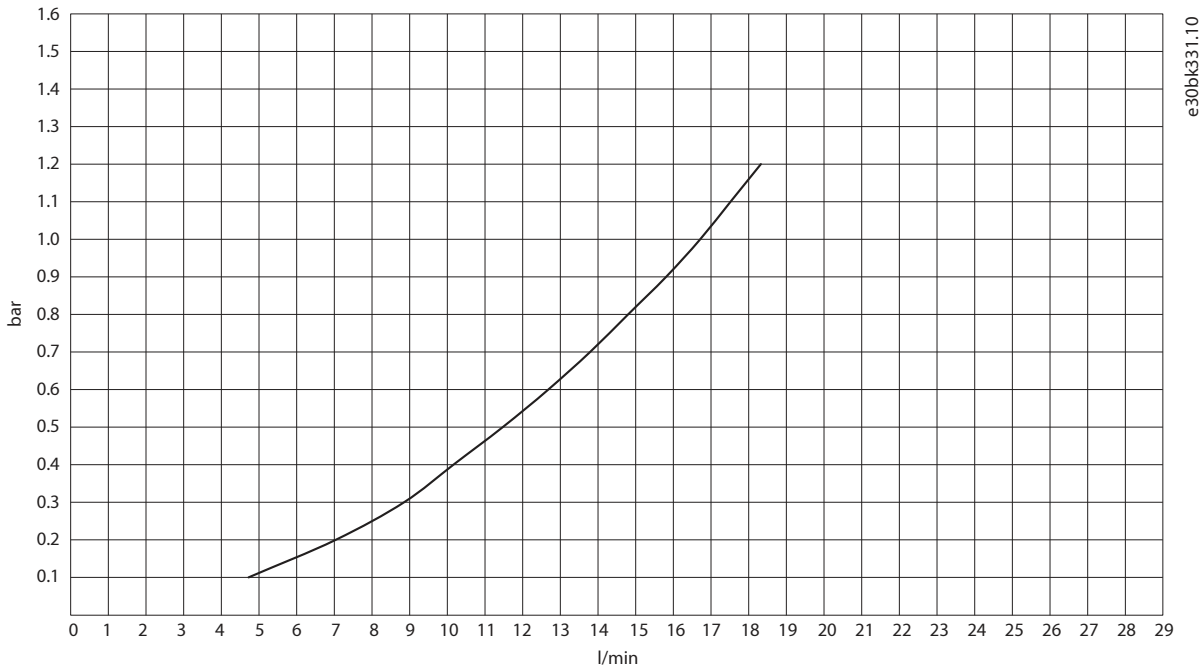

Figure 63: Pressure Drop with Water, DC Filter for DC/DC Converter OF7D1, 1200 A

6.4.7 Cooling Circuit Connectors

The cooling system has cooling circuit connectors located in the manifold plate. The internal thread size of the cooling circuit connectors is G1/2. The depth of the threads is 13 mm (0.5 in). The maximum tightening torque is 30 Nm (266 in-lb). The push-in connectors are available as an option.

The inlet connectors are at the bottom of the system module. The outlet connectors can be at the top or at the bottom.

If the optional outlet connectors at the top are used, the outlet connectors at the bottom must be closed with a plug.

Table 19: Recommended Connectors

Connector	Tightening torque [Nm (in-lb)]	Pipe	Pipe ferrule
Parker 69111621 MALE STUD 1/2"BSPP SS STEEL 31 6L D16 EPDM SEAL	20–30 (177–266)	PA 16/13 pipe	Parker 1827-16-13

6.4.7.1 Pipe Ferrules

⚠ CAUTION

LEAKAGE HAZARD

When the product is used in an ambient temperature of below 0 °C (32 °F), the plastic pipe shrinks more than the metallic connector, and can cause the coolant to leak.

- In freezing ambient temperatures, use stainless steel pipe ferrules.

To make sure that the ends of the pipes stay straight, it is possible to use pipe ferrules. The pipe ferrules must be round. The pipe ferrules cannot be made of red brass or steel because of corrosion. Allowed material for the pipe ferrules is stainless steel. See [6.4.2 Materials](#).

Insert the pipe ferrule fully into the pipe.

6.4.7.2 Insertion of Pipes into Cooling Circuit Connectors

The insertion length of a Ø16 mm (0.63 in) pipe is 29 mm (1.14 in). Make a mark on the pipe where it can be checked that the pipe is correctly inserted into the cooling circuit connector.

To remove the pipe from the connector, push the release sleeve towards the connector and pull out the pipe.

For cold PA11 plastic pipes, the minimum bending radius is 138 mm (5.43 in). A smaller bending radius requires heating of the pipe. See [6.4.8 Cooling Circuit Pipes](#).

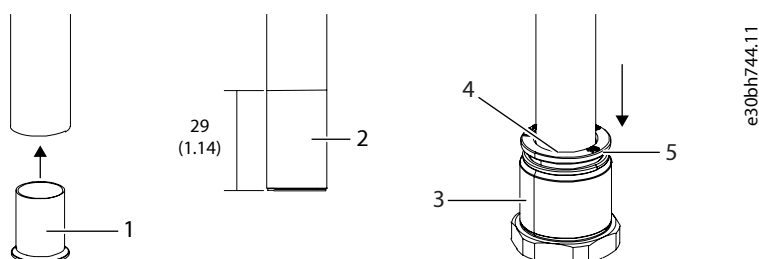

Figure 64: Inserting a Pipe into the Cooling Circuit Connector, mm (in)

1	The pipe ferrule	2	The pipe ferrule inside the pipe
3	A cooling circuit connector (available as option)	4	The mark in the pipe
5	The release sleeve		

6.4.7.3 Inlet and Outlet Connectors of System Modules

NOTICE

INCORRECT INLET AND OUTLET CONNECTIONS IN THE COOLING SYSTEM

If inlet and outlet connectors are connected incorrectly, the cooling does not work as expected. Incorrect cooling can damage the product.

- Make the connections carefully.

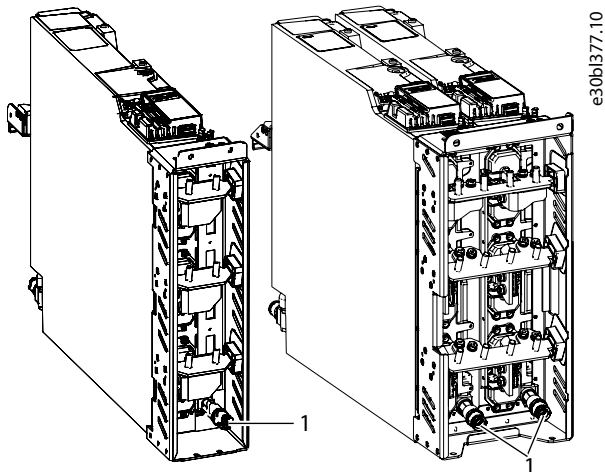

Figure 65: Inlet Connectors of IM10L (left) and IM12L (right)

1 Inlet connectors

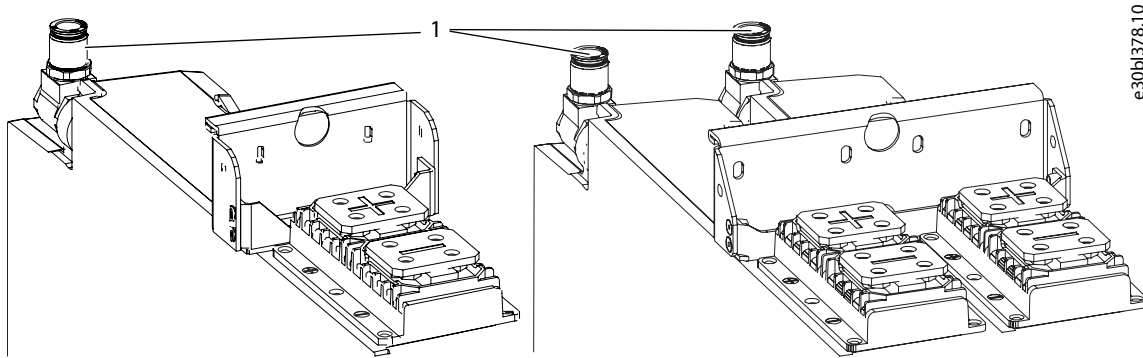

Figure 66: Outlet Connectors of IM10L (left) and IM12L (right)

1 Outlet connectors

6.4.7.4 Inlet and Outlet Connectors of System Modules with Integration Units

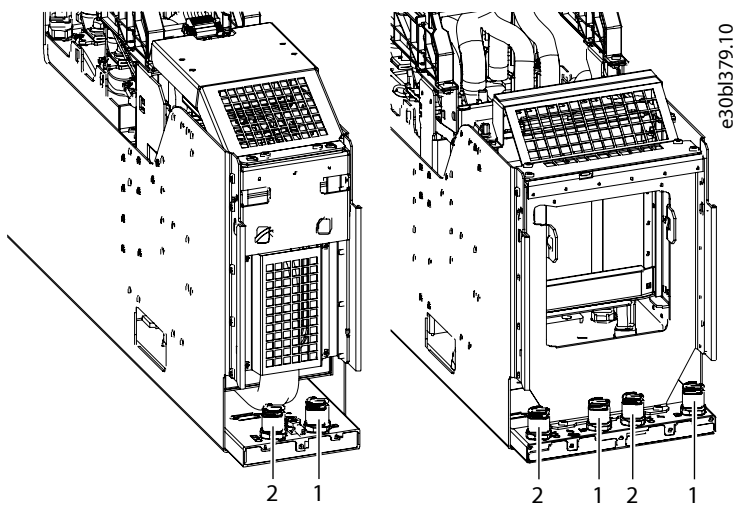

Figure 67: Inlet and Outlet Connectors of IR10L (left) and IR12L (right)

1 Inlet connector

2 Outlet connector

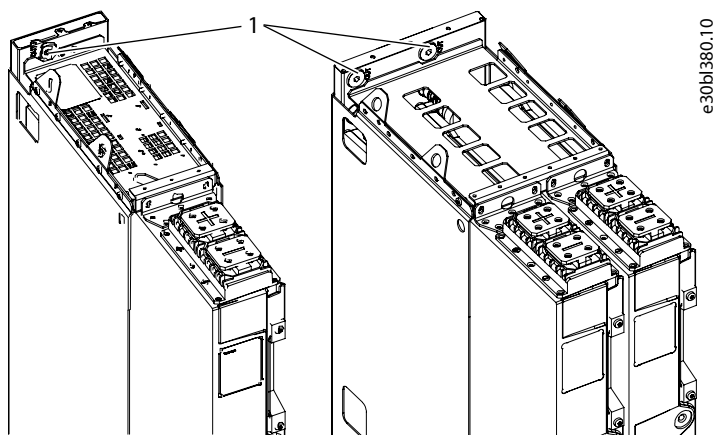

Figure 68: Optional Outlet Connectors of IR10L (left) and IR12L (right)

1 Optional outlet connector

6.4.7.5 Inlet and Outlet Connectors of System Modules with Short Integration Units

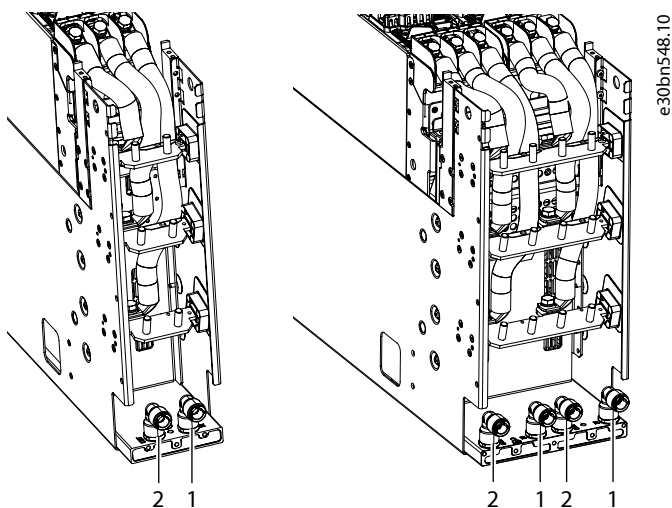

Figure 69: Inlet and Outlet Connectors of IR10/AR10/DR10/BR10 (+AE01) (left) and IR12L/AR12/DR12L/BR12L (+AE01) (right)

1 Inlet connector

2 Outlet connector

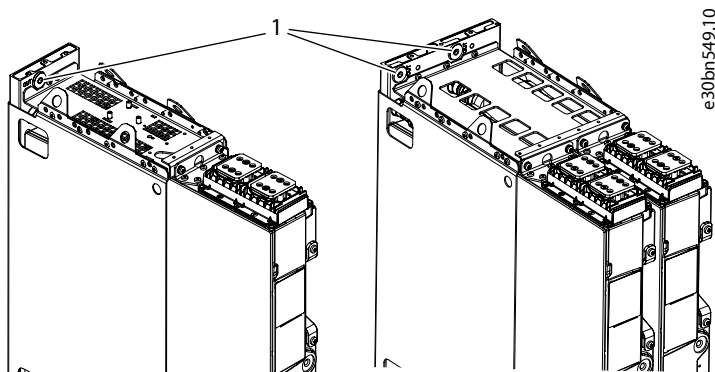
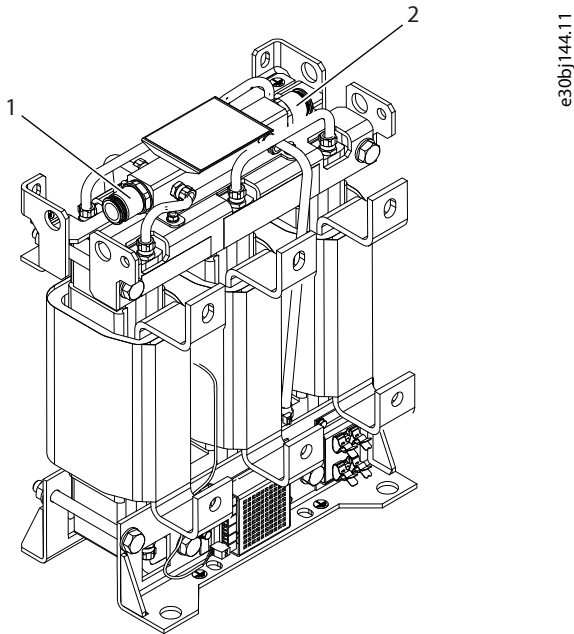

Figure 70: Optional Outlet Connectors of IR10/AR10/DR10/BR10 (+AE01) (left) and IR12L/AR12/DR12L/BR12L (+AE01) (right)

1 Optional outlet connector

6.4.7.6 Inlet and Outlet Connectors of the L Filter



e30bj144.1 1

Figure 71: Inlet and Outlet Connectors of the L Filter

1	Inlet/outlet connector	2	Inlet/outlet connector
---	------------------------	---	------------------------

6.4.7.7 Inlet and Outlet Connectors of the Reactor

The reactor has cooling circuit connectors at the top of the filter. Each connector can be used for coolant input or output.

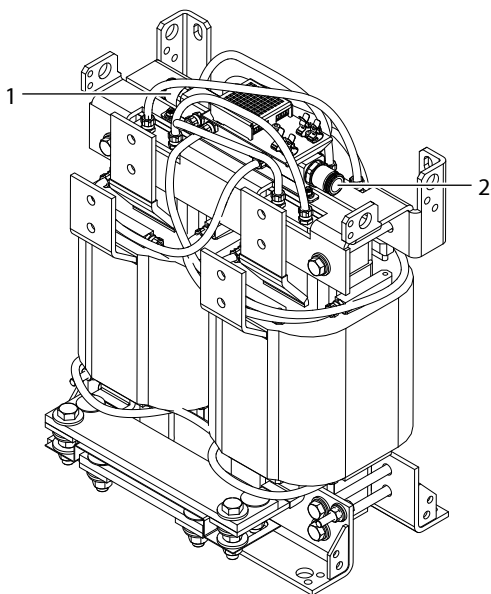

e30bn715.10

Figure 72: Inlet and Outlet Connectors of the Reactor (SISO Filter)

1	Inlet/outlet connector	2	Inlet/outlet connector
---	------------------------	---	------------------------

6.4.8 Cooling Circuit Pipes

The pipes used in the cooling circuit are PA11 plastic pipes with a diameter of Ø16/13 mm (0.63/0.51 in) (Rilsan model code BESNOP40TL).

There are 2 ways to make permanent bends to the pipes.

- The quickest and easiest way is to make the bend in the air by bending it by hand. Do this if only 1 bend is needed and the dimensions do not matter, or the dimension can be adjusted by cutting the pipe after bending.
- If multiple precise pipes with several bends are needed, it is recommended to use a bending jig. There are commercial jigs on the market (for example, Eiskoffer Bending Kit from Alphacool), but the jig can be also self-made from plywood or some other easy-to-work material. But the material must be able to withstand at least 200 °C (392 °F).

Required tools for bending the pipes:

- Gloves
- Adjustable heat gun
- Round silicone rubber cord
 - Ø12–12.5 mm (0.47–0.49 in)
 - Solid
 - Hardness: minimum 60 Shore A, recommended >70 Shore A

Recommended tools for bending the pipes:

- Water bucket or sink
- Distilled water
- Bending jig

NOTICE

OVERHEATING OF THE PIPES

If the pipe is overheated, the wall thickness and pressure resistance change, and the shape of the pipe collapses easily.

- Do not heat the pipes above 180 °C (356 °F).

NOTICE

UNEVEN HEATING OF THE PIPES

If the pipe is heated unevenly or over a too small area, it wrinkles easily when the pipe is bent. The wall strength and pressure resistance at the wrinkled point is uncertain.

- Before bending the pipes, heat the pipes evenly and over the whole bending area.

6.4.8.1 Bending Pipes in the Air

1. Insert the silicon cord into the pipe and to the bending location.

It is recommended that the pipe end is at least 5 cm (2 in) from the bending area. If the bending area is too close to the pipe end, the pipe end can become oval, which can cause the pipe and fitting joint to leak.

It is recommended to moisten the cord with distilled water to make it easier to insert into the pipe.

The cord is inserted into the pipe before it is heated, to produce equal counter pressure and to prevent the tube from buckling. The hard pipe is easy to bend evenly with the cord inside.

2. Set the heat gun upright on the table and set the temperature to 350 °C (662 °F).

Make sure that the heat gun does not fall down.

3. Slowly move the pipe back and forth while rotating it over the heat gun.

The aim is to heat the pipe evenly over the entire bending area to around 150–170 °C (302–338 °F). Examples of heating times:

- When making a simple L-bend, a suitable heating time is approximately 2 minutes for a distance of 5–10 cm (2–4 in).
- When making a U-bend, the heating time is approximately 4 minutes for 15–20 cm (6–8 in).

Beware of overheating. If the pipe temperature rises above 180 °C (356 °F), it starts to melt, and the wall thickness can change. As the temperature of the pipe approaches the melting point, the pipe changes color from cloudy to clear, and starts to smell burned.

4. Once the tube is heated all around the bending area, bend it to the desired shape.

The recommended minimum bending radius >30 mm (1.18 in).

5. Hold the pipe in the desired position and cool it quickly, for example, in a sink or under a tap.

➡ If the pipe was heated enough, the bending is permanent.

6. Pull the cord out of the pipe. If the bend is steep, it can be necessary to open the bend slightly to get out the cord.
7. After bending the pipe, check the circularity of the pipe ends.

A Ø16/13 mm (0.63/0.51 in) tube ferrule (for example, 1827-16-13 from Parker) can be inserted into the pipe as an aid to assess the circularity of the pipe.

6.4.8.2 Bending Pipes with a Bending Jig

These instructions were prepared with the Eiskoffer bending kit from Alphacool, but other commercial or self-made jigs can also be used.

1. Prepare the bending jig.
2. Insert the silicon cord in to the pipe and to the bending location.

It is recommended that the pipe end is at least 5 cm (2 in) from the bending area. If the bending area is too close to the pipe end, the pipe end can become oval, which can cause the pipe and fitting joint to leak.

It is recommended to moisten the cord with distilled water to make it easier to insert into the pipe.

The cord is inserted into the pipe before it is heated to produce equal counter pressure and to prevent the tube from buckling. The hard pipe is easy to bend evenly with the cord inside.

3. With the cord inside, bend the pipe to the jig.

The recommended minimum bending radius >30 mm (1.18 in).

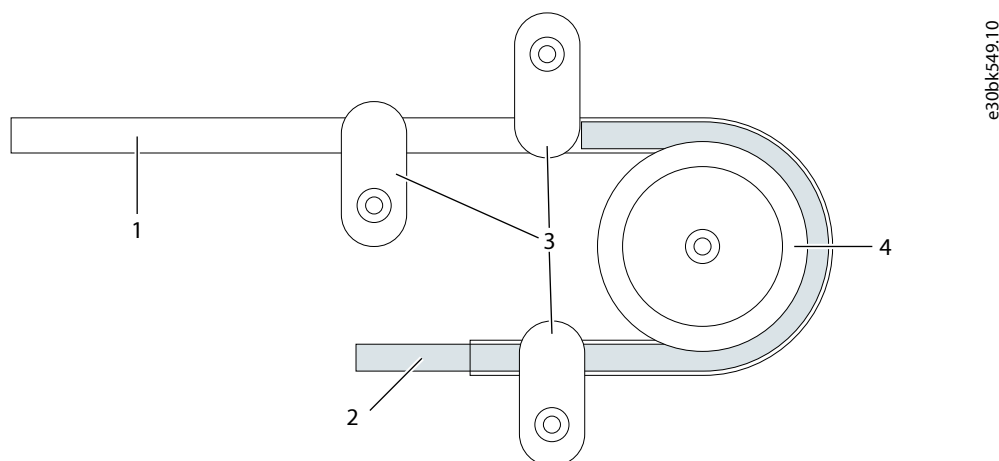

Figure 73: Pipe Bending Jig Example

1	Pipe	2	Silicon cord
3	Pipe holders	4	Bending wheel

- Set the heat gun temperature to 200 °C (392 °F).
- Slowly move the heat gun back and forth over the entire bending area.

The aim is to heat the pipe evenly over the entire bending area to around 150–170 °C (302–338 °F). When the pipe is heated only at the outer edge, it takes time to heat the inner edge of the pipe as well. Therefore, the temperature used is fairly low and, for example, when making a 180° bend with radius Ø32 mm (Ø1.26 in), the suitable heating time is 10 minutes.

Beware of overheating. If the pipe temperature rises above 180 °C (356 °F), it starts to melt, and the wall thickness can change. As the temperature of the pipe approaches the melting point, the pipe changes color from cloudy to clear, and starts to smell burned.

- Before removing the pipe from the jig, let it cool completely. The cooling takes more than 10 minutes.

To accelerate the cooling process, submerge the jig and pipe in water.

- Once the pipe has cooled, remove it from the jig.

↻ If the pipe was heated enough, the bending is permanent.

- Pull the cord out of the pipe. If the bend is steep, it can be necessary to open the bend slightly to get out the cord.
- After bending the pipe, check the circularity of the pipe ends.

A Ø16/13 mm (0.63/0.51 in) tube ferrule (for example, 1827-16-13 from Parker) can be inserted into the pipe as an aid to assess the circularity of the pipe.

An alternative way to use the bending jig is to preheat the pipes as advised in [6.4.8.1 Bending Pipes in the Air](#), and then fold them into the jig and let them cool down.

6.4.9 Filling the Cooling System

Prerequisites:

- Fill 1 system module at a time.
- Make sure that there is a point of exit for air in the cooling system during filling.

- Use a relief valve to limit the pressure to a maximum of 5 bar. The location of the relief valve affects the pressure. The maximum pressure of the cooling system is 5 bar (72.5 psi).
- The minimum filling flow rate of the cooling system is 10 l/min. The stronger the flow, the faster the cooling system is filled.

NOTICE

The numbering of the valves can be different than the numbers mentioned in these instructions. These instructions use the valve numbering of the Danfoss cooling module.

Use these instructions to add liquid into the cooling system and to deair the cooling system.

Procedure

1. Mix the coolant in a sufficiently large container.

The necessary amount of coolant depends on the size of the cooling system.

2. Connect hoses to the input and output valves A (V212) and B (V213) of the drive side of the cooling module.
3. Connect a filling pump to the valve A (V212).
4. Close the pump shut-off valve C (V112 if you have a Danfoss cooling module and the single-pump option +SAP1, V112, and V113 if you have the dual-pump option +SAP2).
5. Put the hose of the filling pump into the coolant. Make sure that air does not go into the hose.
6. Hang the other hose over the container.

➡ It is easy to see when all the air has come out of the cooling system.

7. Close all the valves in cabinets C1 and C2 except for the valves V5, V6, V7, and V8 of the first system module (M1).

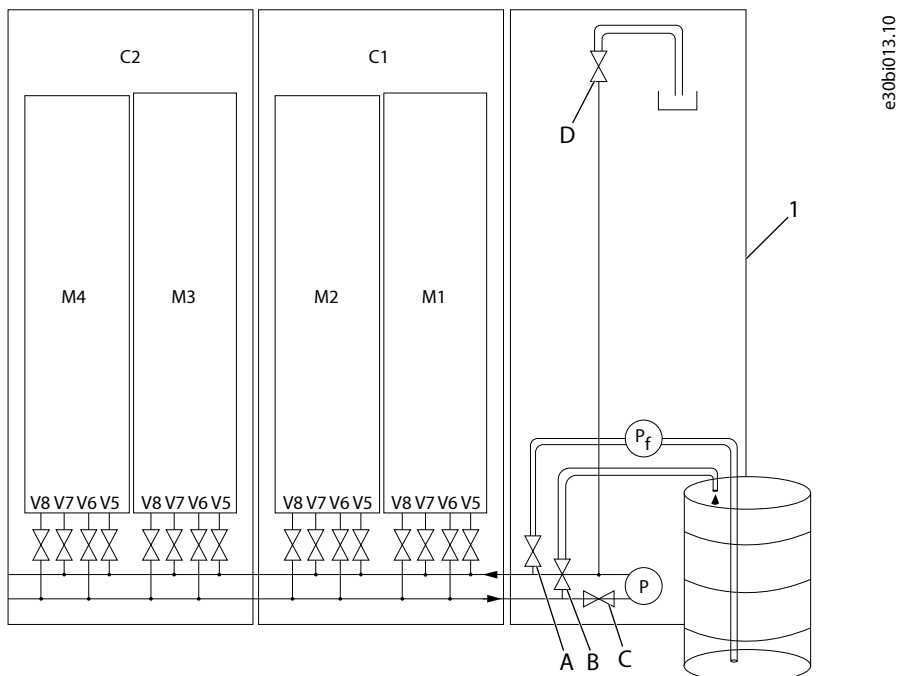

Figure 74: Example of Filling the Cooling System with Liquid

1	Cooling module	A	Filling valve
B	Draining valve	C	Pump shut-off valve
C1	First cabinet	C2	Second cabinet

D	De-airing valve	P_f	Filling pump
P	Pump, cooling module		

8. Open the valves A (V212) and B (V213) of the cooling module.
9. For a Danfoss cooling module, make sure that the valve V211 is open.

The valve V211 is in series with V212.

10. Start the filling pump P_f .
11. Wait for the system module M1 to fill up.

See the table for examples of filling times.

Flow rate	Time [minutes]
10 l/min	10
15 l/min	1

→ When there are no longer air bubbles coming out from the hose hanging over the container, the system module is filled.

12. To exhaust the last air out of the cooling system, stop the filling pump for 10 s and restart it.
13. Stop the filling pump.
14. Close the valves A (V212) and B (V213) of the cooling module.
15. Close the valves V5, V6, V7, and V8 of the 1st system module (M1).
16. Repeat the steps 7.-14. for each of the system modules in turn.
17. Open the valve A (V212) of the cooling module.
18. Open the pump shut-off valve C.

Use V112 for option +SAP1.

Use V112 and V113 for option +SAP2.

19. Open the de-airing valve D (V218) of the cooling module.
20. Put a container under the hose that is attached to the de-airing valve D (V218).
21. Start the filling pump P_f .
22. Wait until liquid comes out of the de-airing valve D (V218).
23. Close the de-airing valve D (V218).
24. Keep on filling until the specified liquid surface or system pressure is reached.

For a Danfoss cooling module, keep on filling until the liquid surface reaches the default level marked in the indication pipe of the expansion vessel.

25. Stop the filling pump.
26. Adjust the correct pressure or liquid surface level according to the cooling module manual.

For a Danfoss cooling module, adjust the correct system pressure via the pneumatic connection of the expansion vessel.

27. Close the valves A and B (V212 and V213) of the cooling module.

For a Danfoss cooling module, also close the valve V211 which is in series with V212.

28. Open all the valves of all the system modules.

To ensure equal coolant flow to each system module, open the valves equally.

29. Start the pump P of the cooling module and let it run for a few minutes.

If the pressure of the cooling system drops, add more coolant or adjust the pressure in the cooling system according to the instructions in the steps 7.-14. and 26.

30. Detach the filling pump P_f and the hoses connected to the valves A and B (V212 and V213).

31. Start the cooling module.

32. Stop the cooling module for 10 s and restart it. Repeat if necessary.

➔ The cooling system is now ready for operation.

6.5 Condensation

Condensation must be avoided.

Therefore, the temperature of the coolant must be kept higher than the dewpoint in the electrical room. Use [Figure 75](#) to determine if the drive operating conditions (combination of room temperature, humidity, and coolant temperature) are safe. The graph can also be used to select the temperature for the coolant. The coolant temperature must be higher than the dewpoint.

Increasing the temperature of the coolant above the data in the loadability charts decreases the nominal output current of the drive. The data of the graph is valid at sea level altitude (1013 mbar).

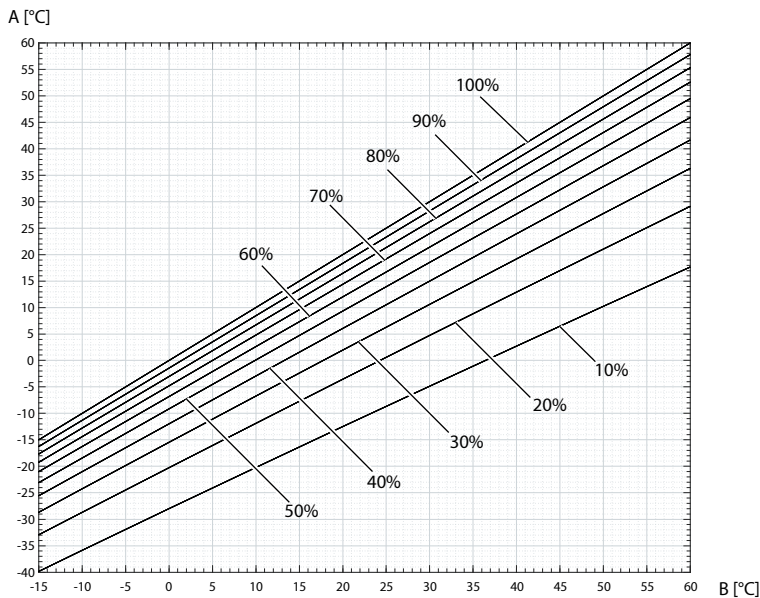

Figure 75: Dewpoint Temperature at Relative Humidity 100...10%

A Dewpoint temperature

B Ambient temperature

The Danfoss cooling module has an automatic condensation prevention system.

6.6 Air Cooling Requirements

iC7 Series Liquid-cooled System Modules are liquid-cooled, but in a liquid-cooled drive system, there are always some heat losses to the air. The heat losses come from the busbars, fuses, and other auxiliary components. When installing the system modules and other components to an enclosure, ensure that there is sufficient airflow in each section.

The ambient conditions in each enclosure section must be in line with the specifications for the drive. Make sure that the temperature of the cooling air does not become higher than the maximum ambient temperature or lower than the minimum ambient temperature of the drive.

The structure of the enclosure must be such, that the air can move freely through the enclosure, and the air flow is directed to the components which require cooling.

The door or bottom part of the enclosure must have air gaps for air intake, and outlet air gaps at the top. The inlet and outlet air gaps must obey the requirements set by the selected protection rating. The structure in the enclosure must move the hot air to the outlet at the top of the enclosure. The structure must also make sure that the hot air goes out of the enclosure and does not come back in.

Monitor the air cooling capability inside the enclosure. The system modules only monitor the temperature of the modules and filters. Ensure sufficient air flow through the critical areas. Critical areas for air-cooling are:

- DC and AC fuses
- Terminals
- Busbars
- Power cables
- Electrical components

Considerations for directing the air flow:

- Block the gaps and empty space between the side wall of the enclosure and the system modules to direct air flow to the areas that need cooling.
- If the adjacent enclosure section has lower air pressure, there must be a wall between the sections to prevent air from escaping into the adjacent section.
- An air deflector is recommended above the DC fuses to force the air to flush the fuses.
- The airflow rate must be more than 2 m/s when the temperature inside the enclosure is +40...+60 °C (+104...+140 °F).

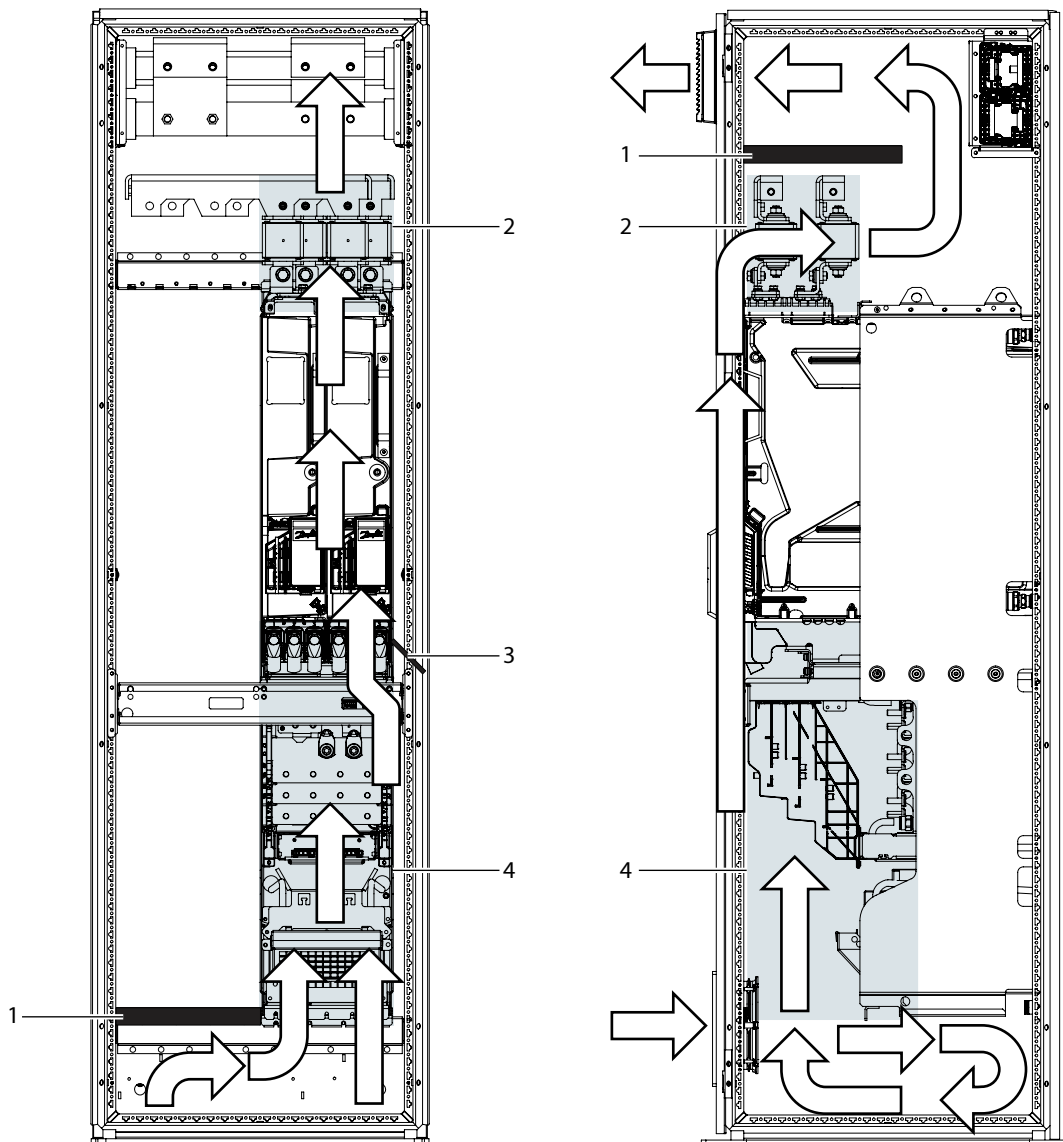

e30bk506.11

Figure 76: Example of Air Circulation Inside an Enclosure

1	Air deflector	2	Critical area (DC fuses and busbars)
3	Air block between wall and system module	4	Critical area (fuses, terminals, busbars, internal power cables, electrical components, mains and motor cables)

7 Electrical Installation

7.1 Fuses of the Drive System

The drive system must be equipped with ultra-rapid AC fuses to limit the damage of the drive system. Use these fuses to achieve sufficient protection against short circuits. Select the supply cable protection according to local regulations.

DC fuses must be installed for parallel units where necessary to limit the damage of the drive system. Each DC supply line must be equipped with fuses. The DC fuses are provided with the delivery as option. Do not replace the DC fuses with any other types.

The protective devices must be integrated within the same overall assembly as the system module.

The fuse tables can be found in [10.5.1 General Information on the Fuse Tables](#). The fuse ratings are based on a maximum ambient temperature of 60 °C (140 °F) and a minimum airflow of 2 m/s around the fuse.

To ensure fuse performance, make sure that the available supply short-circuit current is sufficient. See minimum required values ($I_{cp,mr}$) at the fuse location in [10.5.3 AC Fuses for AFE or GC 525–690 V AC, IP00/Open Type](#).

NOTICE

FUSES FROM DIFFERENT MANUFACTURERS

Mixing fuses from different manufacturers can damage the equipment.

- Use fuses from only one manufacturer in the system.

Branch-circuit protection requirements for North America

An UL 489/CSA C22.2 No. 5 listed circuit breaker, or an UL 248/CSA C22.2 No. 106 listed fuse must be provided in the branch circuit supplying this equipment. Select the overcurrent protective device according to the rated supply voltage and rated current of the drive. The overcurrent protective device must have a minimum interrupting rating of 100 kA to meet the maximum SCCR rating of the equipment.

This equipment is equipped with supplementary semiconductor-protection fuses. Therefore, the branch-circuit overcurrent protective device is not required to provide semiconductor-specific protection. All short-circuit protection for the supply conductors must comply with applicable local electrical regulations (for example, NEC in the United States or CEC in Canada).

7.2 Guidelines for DC Connections of System Modules

The DC busbars and cabling must be dimensioned according to local installation regulations and codes, so that the cross-section is sufficiently large for the current flowing at the relevant point. See the DC current ratings in [10.6.1 General Information on the Current Rating Tables](#).

The DC busbar itself must be designed to attain the lowest possible inductance.

Adequate fuse protection for the drive configuration must be provided on the line side and on the DC side. The power cables and busbars must be dimensioned with sufficient thermal and mechanical strength to handle short circuits in the system. See the fuse ratings in [10.5.1 General Information on the Fuse Tables](#).

If the DC voltage is above 1250 V DC, add a surge-protection device (SPD) in the system on the DC bus. See [10.3.3 Extended Wiring Diagram for Energy Storage Applications, GC, AR12L, Voltage Class G7](#).

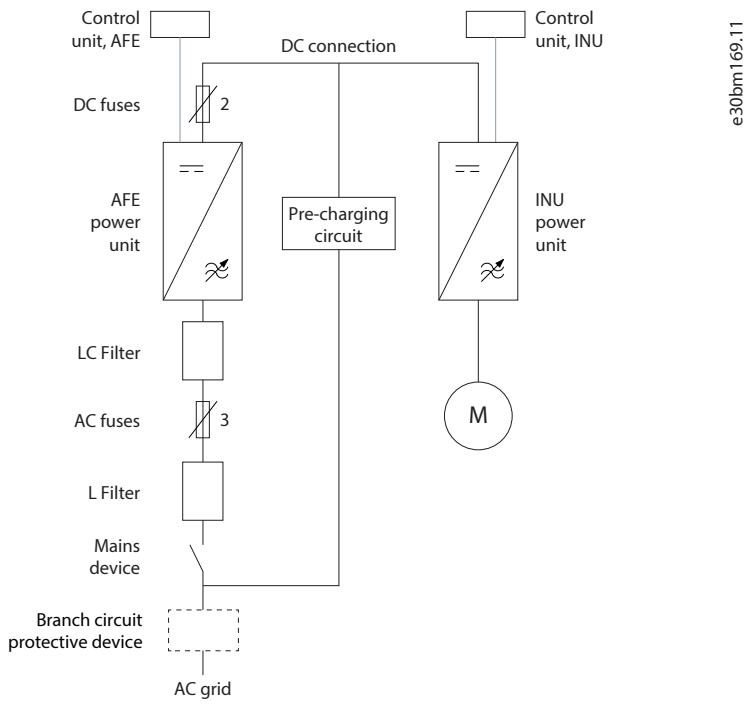

Figure 77: DC Connections of Single Power Units

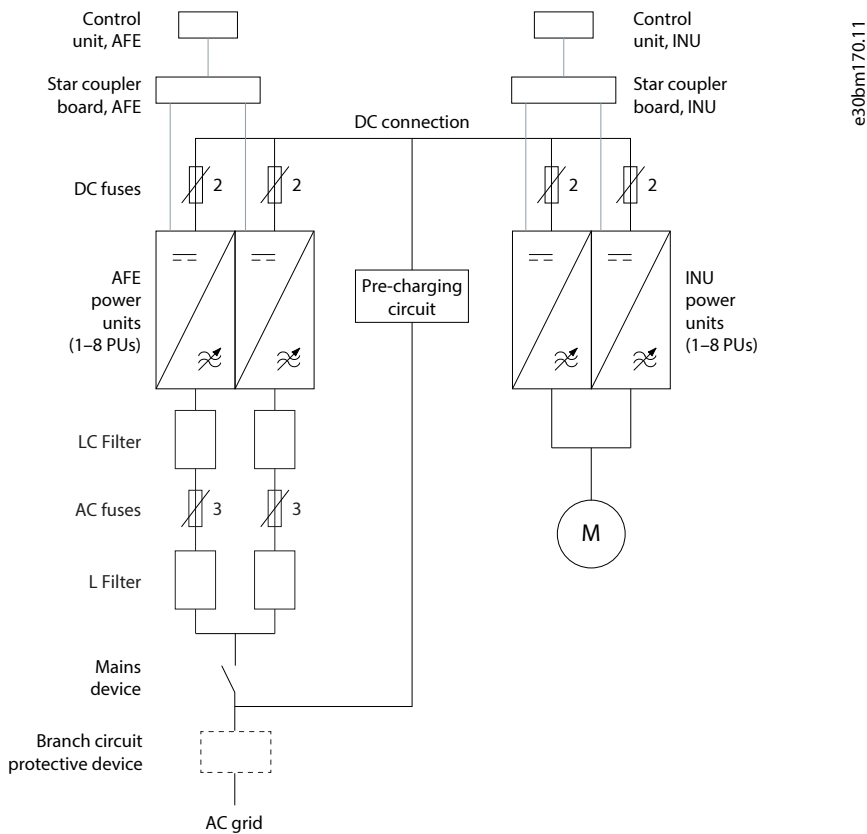
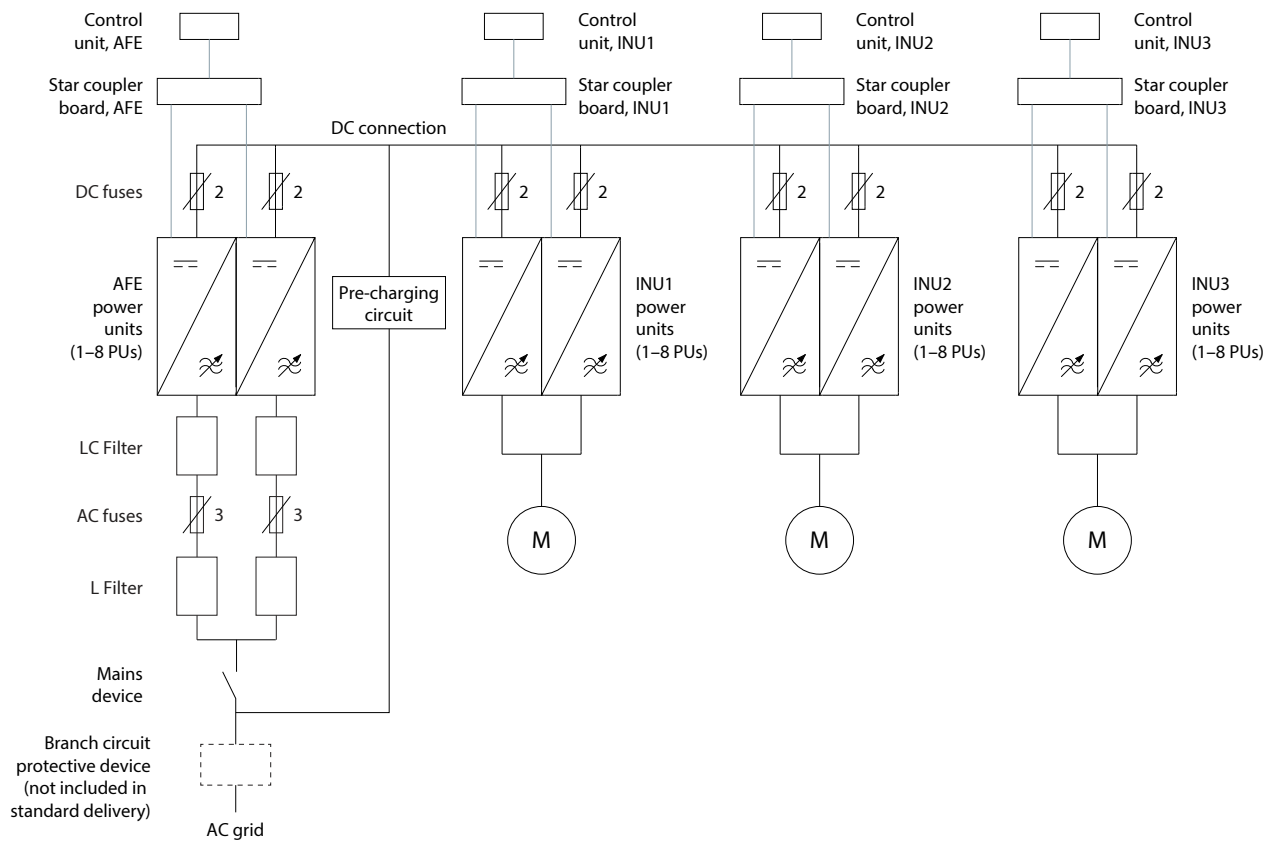

Figure 78: DC Connections of Parallel Power Units



e30bm171.12

Figure 79: DC Connections of a Drive Lineup

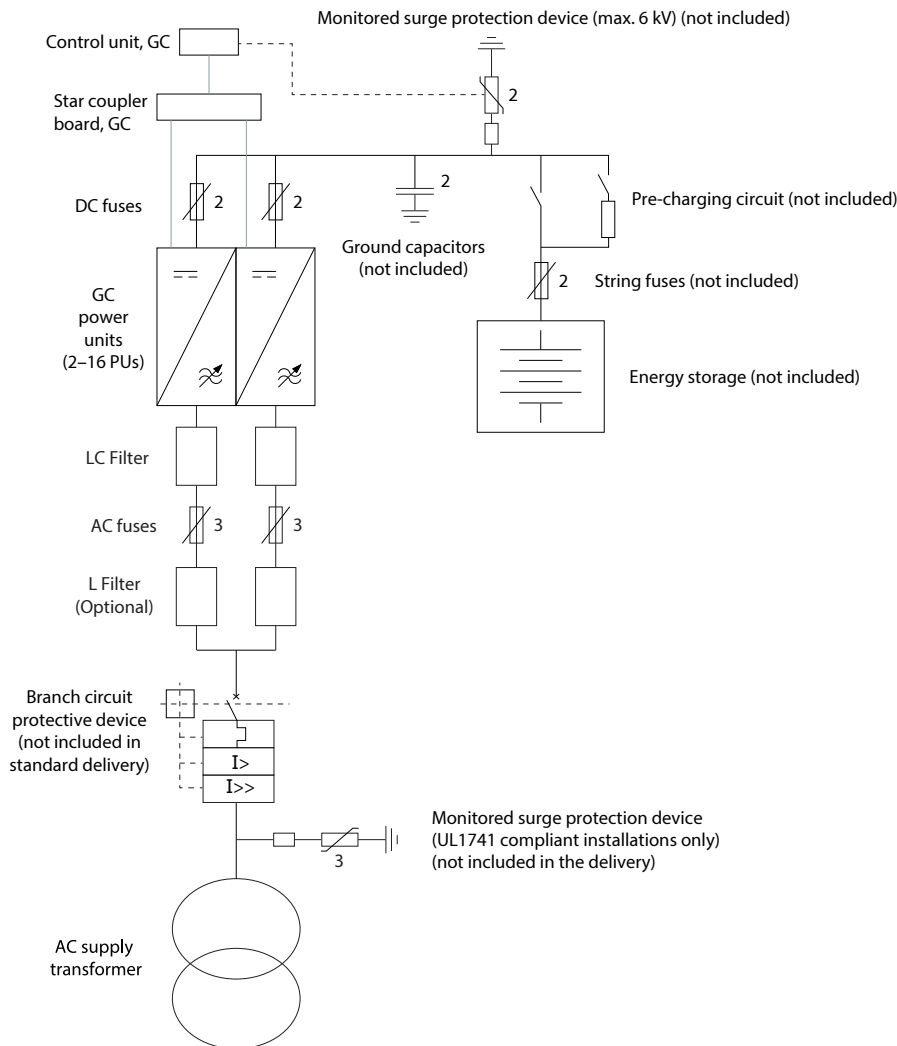

Figure 80: DC Connections for Energy Storage Applications

7.3 Grounding Principles

Ground the product in accordance with applicable standards and directives.

According to IEC 60364-5-54; 543.1, unless local wiring regulations state otherwise, the cross-sectional area of the protective grounding conductor must be at least $\frac{1}{2}$ times of the phase conductor and made of the same material when the phase conductor cross-section is above 35 mm^2 (AWG 2).

The connection must be fixed.

7.4 Grounding the Products

Equipotential bonding of system modules in the cabinet

To ensure safe operation, correct EMC performance, and controlled fault-current paths, all iC7 liquid-cooled system modules must be bonded to the cabinet's main protective earth busbar (PE busbar). The equipotential bonding is established through the mechanical installation interfaces of the modules and the metallic structures of the installation cabinet.

The system module is grounded through module mechanical fixing via the cabinet mounting brackets to the cabinets PE busbars, see [Figure 81](#). These are also connected between the cabinet bodies with a low-impedance screw joint. If the cabinet frame is painted, ensure low contact resistance between these parts by removing, for example, paint between the contact surfaces.

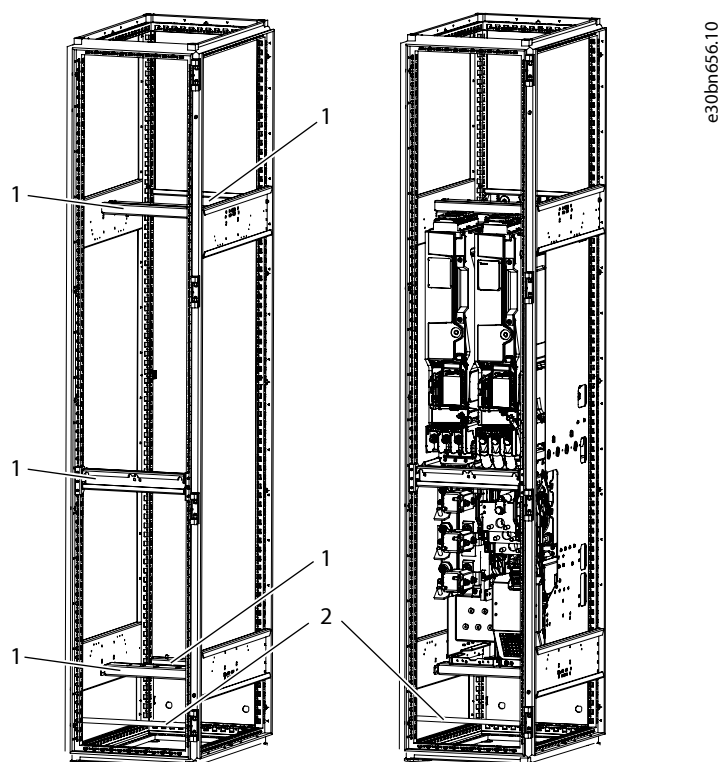

Figure 81: The Mounting Brackets, PE Busbars, and the Installation of System Modules with the Integration Unit into the Cabinet

1	2
Mounting brackets	Enclosure/cabinet PE busbar

The following principles must be applied when integrating the system modules into a cabinet.

Mechanical fixing points as bonding paths

A reliable protective bonding path is formed naturally when the system module is mechanically attached to the cabinet. Equipotential bonding to the PE busbar is achieved through:

- The module mechanical mounting points (Frame-to-cabinet metal interface).
- The cabinet structural components (Mounting brackets, rails, and backplates).
- The metallic frame of the cabinet.
- The contact surfaces must ensure a continuous low-impedance path.

Ensuring galvanic continuity

To ensure a proper conductive connection:

- Remove paint or surface coatings at the mounting points where necessary.
- Use serrated/star washers or conductive hardware to ensure metal to metal contact.
- Ensure that the cabinet frame is bonded to the PE busbar using a low-impedance connection.
- If the cabinet is fully painted or anodized, additional preparation is required to ensure bonding quality.

Supplemental bonding where required

If the mechanical bonding alone does not provide sufficient continuity, for example, due to surface coatings, long current paths, or special EMC requirements, add a dedicated protective bonding conductor between:

- The system module frame.

- The cabinet PE busbar.
- Dimension the conductor according to the applicable standards to ensure that touch voltages remain within the safety limits under all fault conditions.

Bonding of all metal parts in the assembly

All exposed conductive parts in the installation must be connected to the same protective bonding system, including:

- System module frames.
- Integration units.
- Filter housings (L, LCL, LC, dU/dt, CM, sine-wave, DC filters).
- Cabinet rails, support structures, and metal mounting plates.
- Metal cooling components (Piping, manifolds, or brackets).
- This minimizes potential differences and provides a defined HF return path for EMC performance.

Bonding in multi-cabinet installations

In multi-section or multi cabinet enclosures:

- Ensure that the PE busbar is continuous through all sections.
- Bond cabinet frames together at several points using conductive bolts and washers.

Verification of bonding quality

After installation, verify:

- Continuity between each system module frame and PE busbar.
- Resistance levels according to IEC 60364-5-54 and local regulations (Generally $0.1 \leq \Omega$).
- Bonding continuity across all cabinet support structures.

References

See the grounding details of the system modules in the [iC7 Series Liquid-cooled System Modules Installation Guide](#).

See the grounding details of the L filter in the [iC7 Series Liquid-cooled L Filter OF7Z5 Installation Guide](#).

7.5 Cable Requirements

7.5.1 Cable Requirements for Mains and Motor Cables

Follow these requirements for the mains and motor cables used in the drive system.

- Select and install mains cables and motor cables according to the local safety regulations, the input voltage, and the load current of the drive.
- Use motor cables rated for +90 °C (194 °F) surface temperature. Consider the operating temperature of the mains terminals and make sure that the mains cables do not overheat near the input terminals. Sufficient forced air cooling is required for the cables when operating in high ambient temperatures.
- Use symmetrical power cabling with power units connected in parallel. Each power unit must have the same number of cables with an equal cross-section and equal length.

The maximum number of power unit cables and bolts sizes can be found in [10.4.1 General Information on the Cable Tables](#).

Only use symmetrical and shielded 3-phase motor cables. See [Figure 82](#).

Do not use symmetrical and shielded 3-phase cable with individual shield for each phase conductor or single-core phase conductors and PE with or without shield, see [Figure 83](#).

To reach C3 EMC performance, use shielded motor and mains cables.

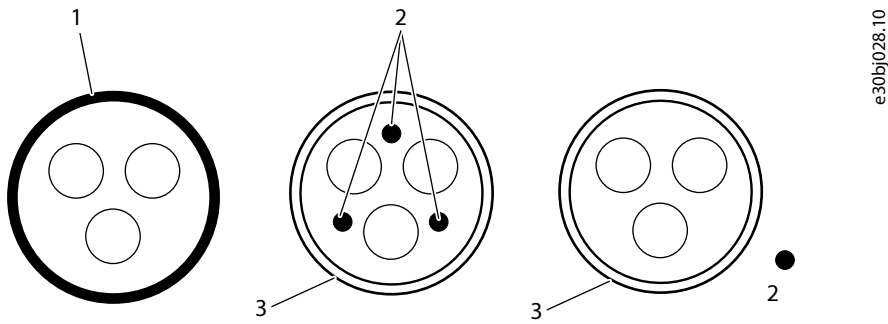

Figure 82: Recommended Cable Types for Mains and Motor Cabling

1	PE conductor and shield	2	PE conductor
3	Shield		

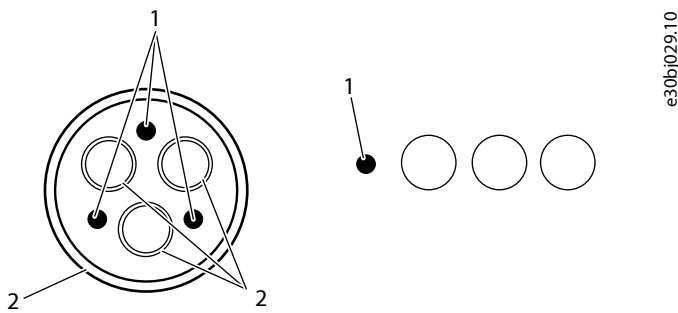

Figure 83: Not Recommended Motor Cable Types

1	PE conductor	2	Shield
---	--------------	---	--------

Although single-core cabling is not recommended, it is sometimes needed in installations due to practical reasons. Note that the C3 EMC performance is not guaranteed when using single-core cabling. The external magnetic field around the phase conductors can be minimized by arranging the phase conductors in an optimized way. The proposed arrangements also improve AC current sharing between parallel phase conductors.

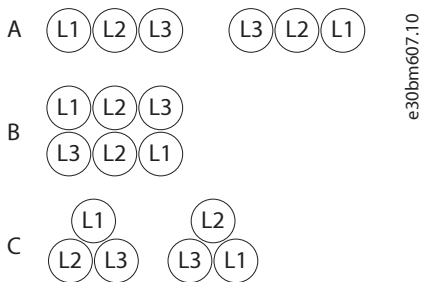

Figure 84: Single-core Cabling: 2 Conductors per Phase or 2 Circuits

A	Alternative A	B	Alternative B
C	Alternative C		

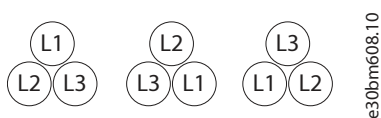

Figure 85: Single-core Cabling: 3 Conductors per Phase or 3 Circuits

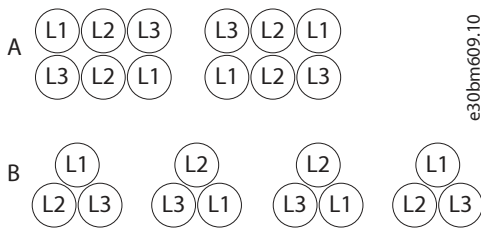

Figure 86: Single-core Cabling: 4 Conductors per Phase or 4 Circuits

A	Alternative A	B	Alternative B
---	---------------	---	---------------

DANGER

USING UNSHIELDED SINGLE-CORE CABLES

If unshielded single-core cables are used with the active front-end module on (ungrounded) IT networks, there can be a dangerous voltage on the non-conductive outer layer of the cable. Contact with this voltage can cause injury or death.

- If unshielded single-core cables are used, be aware of the risks.
- Use recommended cabling methods whenever possible.

7.5.2 Requirements for DC-source Cables of DC/DC Converters

It is recommended to use symmetrical cables with an even number of conductors for DC+ and DC-.

- 3-core cable: Use 2 conductors for DC+ and DC-, and the 3rd conductor for PE.
- 4-core cable: Use 2 conductors for DC+ and 2 conductors for DC-.

It is recommended to use cables with common shielding. Connect the cable shield to the ground at both ends.

If single-core shielded cables are used, ground the cable shield only from 1 end.

Use single-core unshielded cables only if EMI protection is not necessary, or it is ensured by other means.

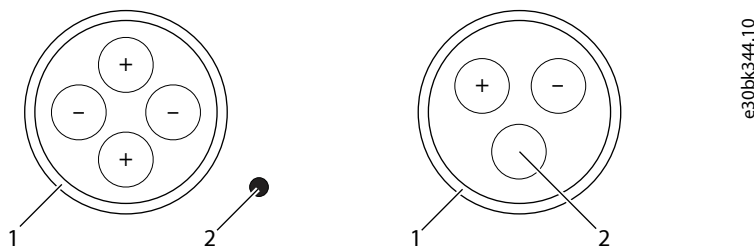

Figure 87: Recommended Cable Types for DC-source Cables

1	Shield	2	PE conductor
---	--------	---	--------------

7.5.3 Cable Requirements for SISO Filter

Same main circuit requirements apply to the SISO filter as described in [7.2 Guidelines for DC Connections of System Modules](#) and [7.5.1 Cable Requirements for Mains and Motor Cables](#).

Keep the cable length between the LC filter or sine-wave filter and the system module as short as possible. The recommended maximum cable length is 3 m (9.8 ft).

Keep the cable length for the feedback loop as short as possible. The recommended maximum cable lengths are:

- Connection between capacitor star points: ≤2 m (6.6 ft)
- DC-link connection to feedback fuses and capacitors: ≤1.5 m (4.9 ft)

7.6 Prerequisites for Cable Installation

Table 20: Minimum Separation Distances between Motor and Other Cables

Length of the shielded motor cable m (ft)	Minimum separation distance between motor and other cables m (ft)
0–50 (0–164)	0.3 (1.0)
50–150 (164–492)	1.0 (3.3)

1. Before starting, make sure that none of the components of the product is live. Read all safety precautions in this guide and other documents available for this product.
2. Make sure that the motor cables are sufficiently far from other cables.
3. The motor cables must cross other cables at an angle of 90°.
4. If it is possible, do not put the motor cables in long parallel lines with other cables.
5. If the motor cables are in parallel with other cables, obey the minimum distances (see [Table 20](#)).
6. The distances are also valid between the motor cables and the signal cables of other systems.
7. The maximum length of shielded motor cables is 150 m (492 ft). If the used motor cables are longer, contact the vendor to get more information. The motor cable length is based on the maximum number of cables for each frame. For example, 416 A INU module is based on 2 parallel cables, and 820 A INU module on 4 parallel cables. The default motor cable operating capacitance is 0.75 nF/m. If some other cable type is used or the number of cables connected in parallel does not match with the recommendations, the maximum motor cable length must be derated so that the maximum total motor cable capacitance is not exceeded.
 - a. Default maximum motor cable setup for 1x10L: $2 \times (3 \times 120 + 70) \text{ mm}^2$, 150 m, 0.75 nF/m $\rightarrow C_{\text{TOT}} = 2 \times 150 \text{ m} \times 0.75 \text{ nF/m} = 225 \text{ nF} = C_{\text{MAX}}$
 - b. Example where the number of motor cables connected in parallel is higher than the default: $3 \times (3 \times 120 + 70) \text{ mm}^2$, 100 m, 0.75 nF/m $\rightarrow C_{\text{TOT}} = 3 \times 100 \text{ m} \times 0.75 \text{ nF/m} = 225 \text{ nF} = C_{\text{MAX}}$
 - c. Example where motor cable capacitance is higher than the default: $2 \times (3 \times 120 + 70) \text{ mm}^2$, 130 m, 0.85 nF/m $\rightarrow C_{\text{TOT}} = 2 \times 130 \text{ m} \times 0.85 \text{ nF/m} = 221 \text{ nF} < C_{\text{MAX}}$
8. The minimum length of the motor cables without output filters is 5 m (16.4 ft).
9. See the maximum cable length of the filters in [7.13.1 dU/dt Filter](#), [7.13.2 Common-mode Filter](#), and in the *iC7 Series Liquid-cooled SISO Filter OF7SI2/OF7SI4/OF7SO2* Installation Guide.
10. Only use symmetrical and shielded motor cables.
11. Use symmetrical power cabling with power units connected in parallel. Each power unit must have the same number of cables with an equal cross-section and equal length.
12. Perform the cable insulation checks if necessary.

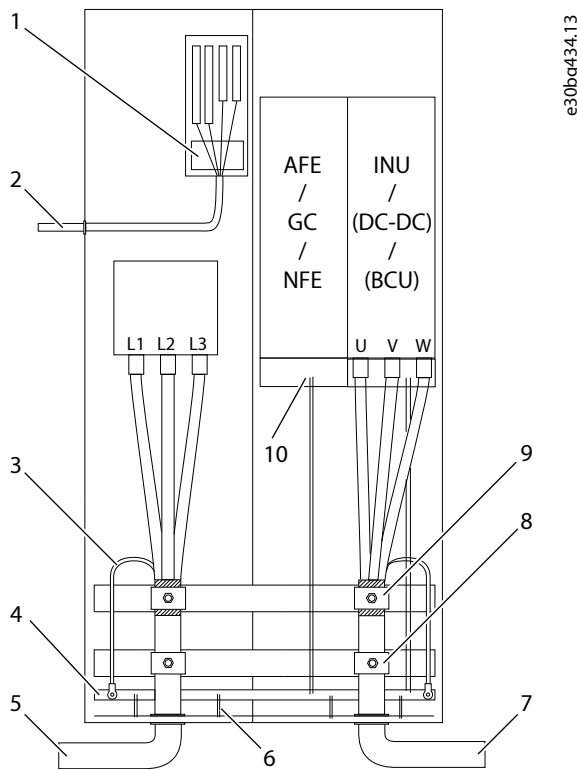

e30bg434.13

Figure 88: Cabling Principle

1	Grounding of the control cable	2	Control cable
3	Grounding conductor	4	PE busbar
5	Mains cables	6	Grounding of the enclosure
7	Motor cables	8	Strain relief
9	The grounding clamp, 360° grounding	10	Grounding of the system module to the PE busbar

7.7 Recommended Installation of Motor Cables

If the power units are connected in parallel without output filters or only with a common-mode filter, the recommended common coupling point of motor cables is at the motor terminals. It is also possible to use an alternative installation method where the common coupling point of the motor cables is near the drives. In this case, to avoid current imbalance, the installation must be symmetrical and the tolerance of cable length (impedance) to common coupling point is maximum 5%. If the cable connections are not symmetrical, use a dU/dt filter or a sine-wave filter.

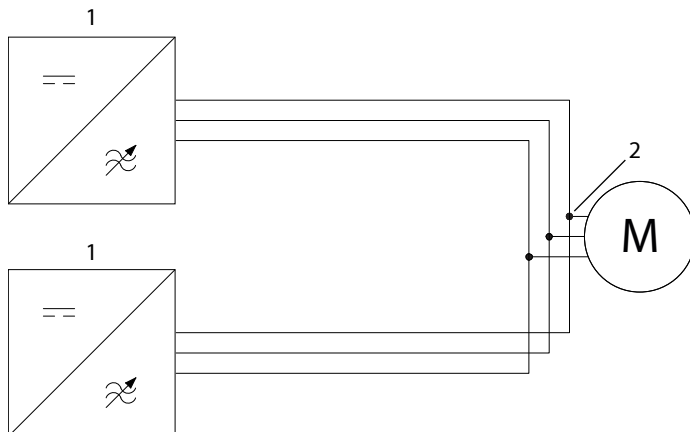

e30bg896.11

Figure 89: Recommended Installation

1 Inverter module	2 Common coupling point at the motor terminals
-------------------	--

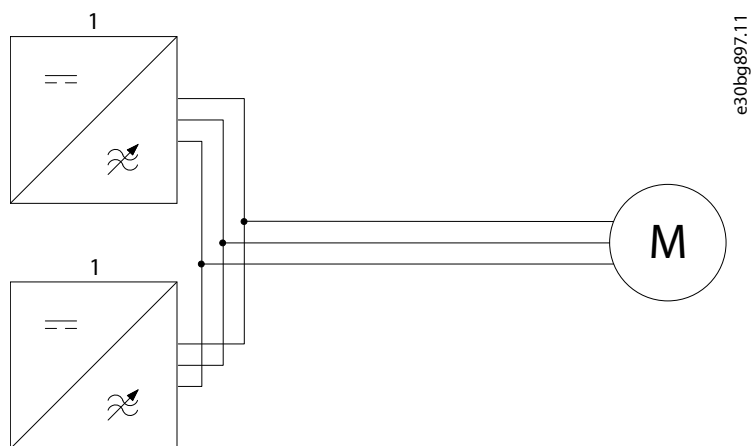

Figure 90: Alternative Installation Method

1 Inverter module

7.8 AFE and Grid Converter Field Cabling Installation

The field cabling terminals are not included in the delivery of the AFE or GC module. Install field cabling to the appropriate terminals. Connect the terminals of the AFE/GC to the LCL Filter terminals with internal cables or busbars. Define the size of the internal cables or busbars according to the nominal current of the drive, and according to local regulations. Also see [10.4.5 Bolt Sizes for the Internal AC Busbars/Cables for AFE and GC Modules, 380–690 V AC](#) and [10.4.7 Internal AC Busbar Sizing within the Enclosure of the AFE/GC Modules](#).

7.9 Installation of Cables with the Power Terminal Adapter

Typically, the motor cables in marine installations have a smaller cross-section compared to the cables in industrial installations, a maximum of 95 mm². That is why more cables must be connected in parallel. If local regulations require the use of several thin parallel motor cables, a power terminal adapter (+AFMC) is available for the installation.

See cable selection requirements in:

- [10.4.13 Marine Cable Sizes for INU Modules 380–500 V AC](#)
- [10.4.14 Marine Cable Sizes for INU Modules 525–690 V AC](#)

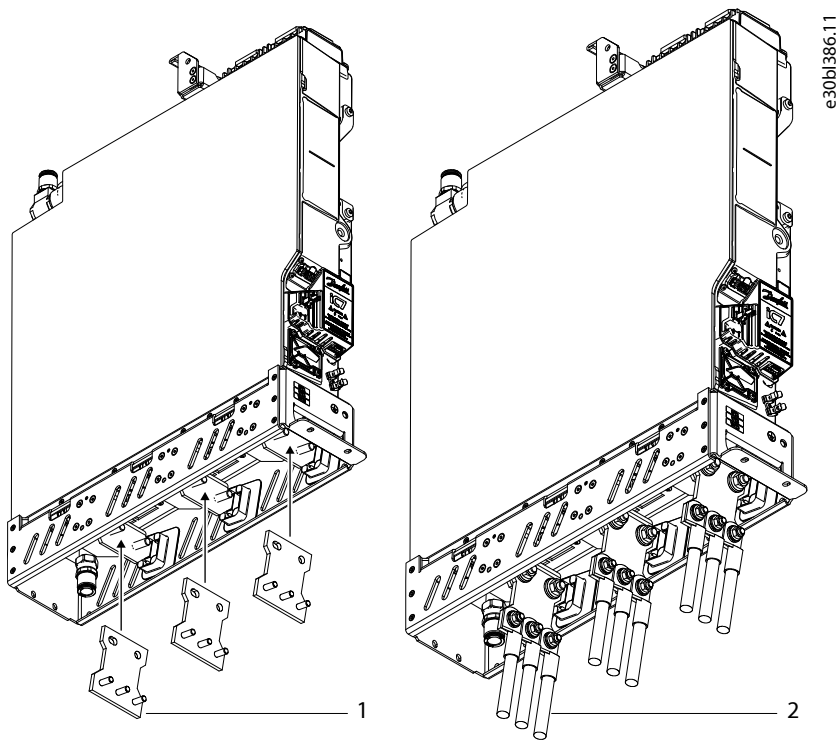

Figure 91: Installation of Cables with the Power Terminal Adapter, Example of IM10L

1 Power terminal adapter	2 Motor cables
--------------------------	----------------

7.10 Installing the DC Fuses to the DC Terminals

Use these instructions to install the DC fuses. The DC fuses are available as option +AKFX, +AKFF, or +AKFS.

1. Attach busbars to the DC fuses. Make sure that the visual indicator (the red dot) of the DC fuse is facing forward.
 - a. Screw the stud on the fuse. Make sure that the stud is inserted as far as it goes. The maximum tightening torque is 15 Nm (133 in-lb).
 - b. Place the busbar on the stud.
 - c. Mount the busbar with an M12 nut and washers, and tighten to torque 45 Nm (398 in-lb).

NOTICE

If the busbars on the DC fuses are not aligned, they can strain the fuse structure and break it over time. When tightening the screws, make sure that the busbars stay aligned.

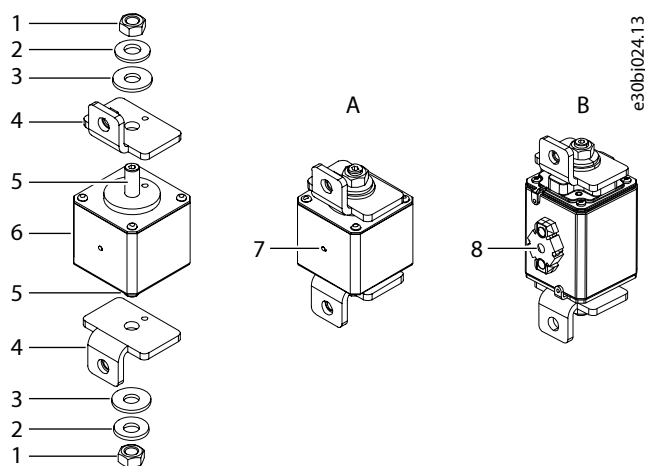

Figure 92: Installing Busbars to the DC Fuses

1	M12 nut	2	M12 spring washer
3	M12 washer	4	Busbar
5	Stud	6	Fuse
7	Visual indicator	8	Striker (visual indicator)
A	Fuse type for the voltage class 07, B5, and A5 products	B	Fuse type for the voltage class G7 products

2. Attach DC-terminal busbars to the DC terminals of the system modules.

- o Use Combi M8 screws.
- o Use the tightening torque 20 Nm (177 in-lb).

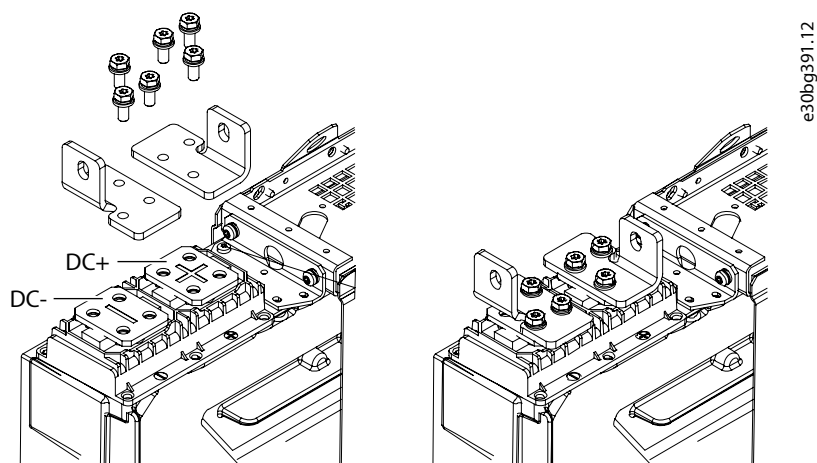

Figure 93: Installing DC-terminal Busbars to the DC Terminals

3. Attach the DC fuse assemblies to the DC-terminal busbars and to the common DC busbars.

- o Use M10 screws and washers.
- o Use the tightening torque 35–40 Nm (310–354 in-lb).
- o Make sure that the common DC busbars are supported properly, so that the weight of the busbars does not stress the fuses and the DC terminals of the module.
- o The common DC busbars are not included in the delivery.

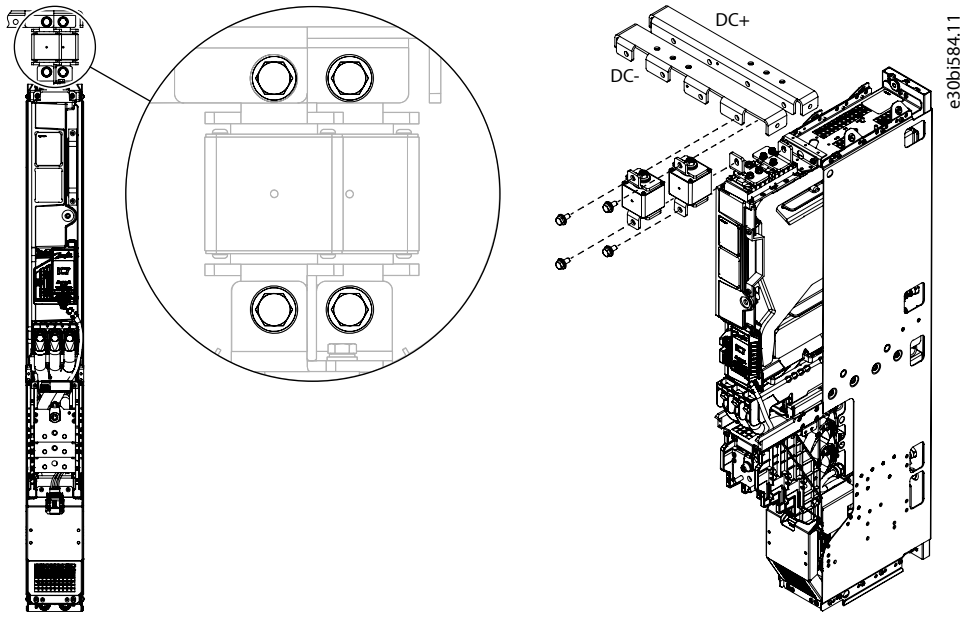

Figure 94: Installing DC Fuse Assemblies

7.11 Auxiliary Power Connection

The auxiliary 24 V DC power connection for the power unit is used for service purposes. When there is a 24 V DC power, it is possible to update the firmware, read or write parameters, and read monitored values.

NOTICE

- When the auxiliary 24 V DC is connected to the power unit, the DC link can become charged up to 25 V DC.

Connector type: Molex Mini-Fit Jr. Receptacle Housing, dual row, 2 circuits, part number: 39012025

Terminal type: Molex Mini-Fit Female Crimp Terminal, part number: 39000039 (bag)

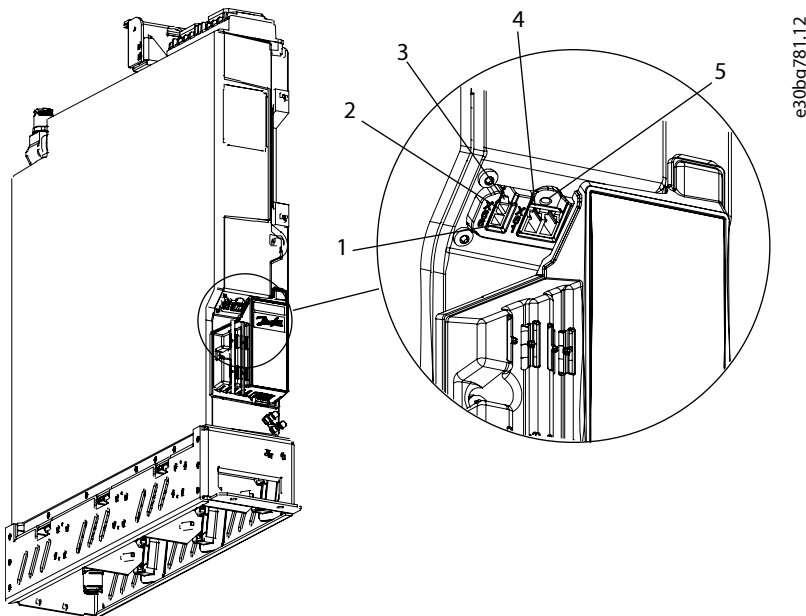

Figure 95: Auxiliary Power Connection for the Power Unit

1	Pin 1	2	Pin 2
3	Auxiliary +24 V DC connection (X66)	4	Optical fiber connection to control unit or star coupler board (X81)
5	Status indicator (See 7.11.1 Indicator Light Definitions.)		

Pin number in X66	Voltage
1	23–26 V DC, 15 W continuous, 25 W peak power
2	0 V DC

1) Cabling must be sufficient to supply the 25 W peak power.

7.11.1 Indicator Light Definitions

Table 21: Definitions of the Indicator Lights in the Power Unit

Indicator color	Indicator function	Description
Green	On	Ready/Run status. Power unit configuration successful, port communication active.
	Blinking fast (10 Hz)	DC-link voltage below the ready level
Orange	On	Starting up
	Blinking fast (10 Hz)	Waiting for connection from star coupler board or control unit
	Blinking (1 Hz)	Waiting for configuration data from control unit or uncommissioned power unit
Red	On	Port communication dropped
	Blinking fast (10 Hz)	Fault in power unit

For the description of the fieldbus indicators (ST, X1, X2), see the relevant application guide.

7.12 Installation in an IT System

If the mains is impedance-grounded (IT), the drive must have the EMC protection level C4. If the drive has the EMC protection level C3, it is necessary to change it to C4. To change the EMC protection level of the drive from C3 to C4, disconnect the LC Filter ground capacitor. See instructions:

- [7.12.1 Changing the EMC Protection Level, AR10L](#)
- [7.12.2 Changing the EMC Protection Level, AR12L \(+AEZ1/+AEZ3\)](#)
- [7.12.3 Changing the EMC Protection Level, LC Filter, OF7Z1, OF7SI2, OF7SI4, Size LC10L](#)
- [7.12.4 Changing the EMC Protection Level, LC Filter, OF7Z1, OF7SI2, OF7SI4, Size LC12L](#)

NOTICE

DAMAGE TO THE PRODUCT FROM INCORRECT EMC LEVEL

The EMC level requirements for the drive depend on the installation environment. An incorrect EMC level can damage the drive.

- Before connecting the drive to the mains, make sure that the EMC level of the drive is correct for the mains.

In a non-dedicated IT system, it is recommended to leave the ground capacitors connected in each AFE and GC in case there are common-mode voltage-sensitive equipment connected to the same supply without a transformer. The typical line-ground voltage when the ground capacitors are connected is close to pure sinusoidal with THDu < 5%. A non-dedicated IT system is defined here as a network where several separate DC links are fed from the same AC supply.

If the ground capacitors are connected in a non-dedicated IT system, note the following:

- Continuous operation during an IT ground fault is not allowed, because a large fault current can flow through the capacitors.
- Possible insulation monitoring devices must be configurable for a larger ground capacitance value (ground capacitor discharge resistors may also need to be removed to maintain high enough insulation resistance).
- Common-mode voltage levels on the DC side increase compared to an IT system without ground capacitors.

In common DC-bus installations supplied through a dedicated transformer or an NFE, and with common-mode voltage-sensitive energy storages or equipment connected to the DC bus, it is recommended to have ground capacitors on the DC-bus side (DC+ to PE and DC- to PE) to balance the DC-bus voltage against ground. In this case, the AC side ground capacitors must be disconnected. This can affect the installation altitude, see more details in [10.8 Technical Data](#). The ground capacitors should be sufficiently larger than the system parasitic capacitance to ground to be effective in limiting the common-mode voltage peaks.

As a rule-of-thumb:

- 10 x system parasitic capacitance ~ 100 V common-mode voltage to ground
- 100 x system parasitic capacitance ~ 10 V common-mode voltage to ground

Continuous operation during ground fault when DC-side ground capacitors are connected is not allowed due to potentially large fault currents.

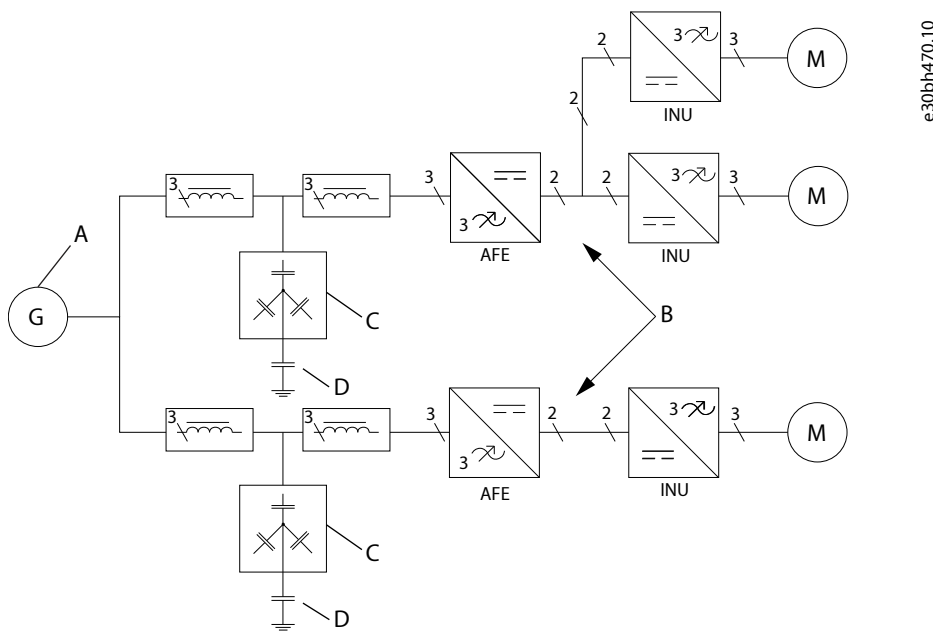

Figure 96: AFE Modules in IT System

A	Generator, floating	B	Separate DC links
C	Filter capacitors	D	Ground capacitor/capacitors on the LC Filter side

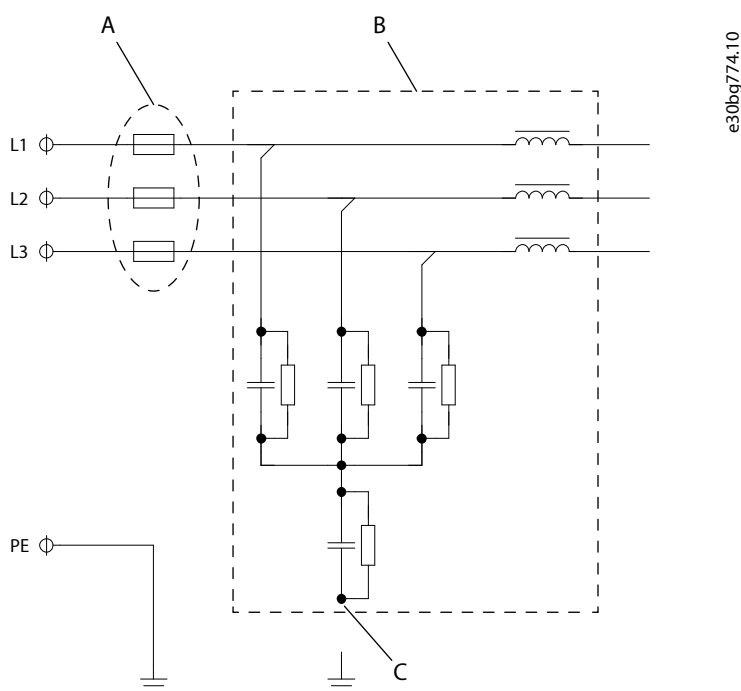

Figure 97: Diagram of the LC Filter

A	AC fuses	B	LC Filter
C	The grounding wire (disconnected)		

The EMC level of the 1500 V voltage class G7 grid converter is C4 as a default (AC side ground capacitor disconnected). The product complies with CISPR11 EMC requirements with a dedicated transformer. Connecting the ground capacitors with sufficient voltage rating in the DC bus is recommended for most applications. The recommended capacitance value is 20 uF from DC+ to ground and 20 uF from DC- to ground per AR12L grid converter module. Multiply the needed capacitance by the number of parallel converters. To meet the CISPR11 EMC standard requirements when capacitors are connected in the DC bus, set the switching frequency to 7.6 kHz.

Changing the EMC level to C3 in a voltage class G7 converter is only recommended for special applications when there is no common-mode sensitive equipment on the DC bus. The recommendation in an AC to AC power conversion system built with 2 grid converters is not to connect any ground capacitors. Ground capacitors on the DC bus are allowed. A dedicated transformer is required on each side of the converter system. Connecting the ground capacitors on either of the AC sides is not allowed in this configuration. The transformer must follow the Danfoss recommendation for phase-to-ground voltage peak and dU/dt withstand.

7.12.1 Changing the EMC Protection Level, AR10L

In an IT system, to change the EMC protection level of the drive from C3 to C4, disconnect the LC Filter ground capacitor.

Procedure

1. Loosen the screw of the grounding wire of the LC Filter.
2. Remove the grounding wire from the grounding terminal.
3. Move the cable lug of the grounding wire with the screw onto the insulator and tighten the screw (maximum 0.5 Nm (4.4 in-lb)).

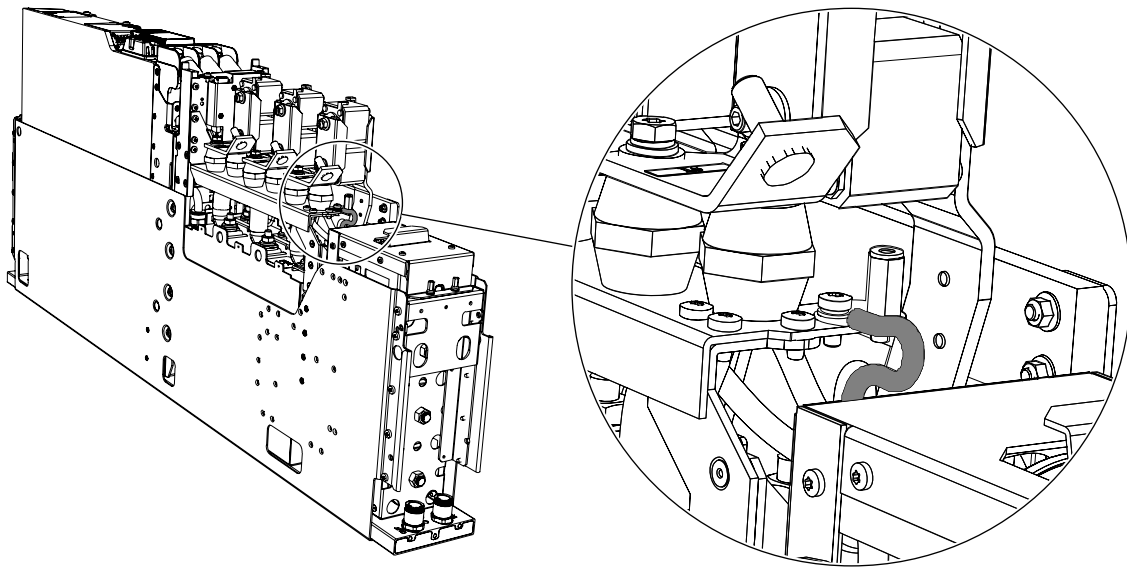

e30bg861.11

Figure 98: Level C3

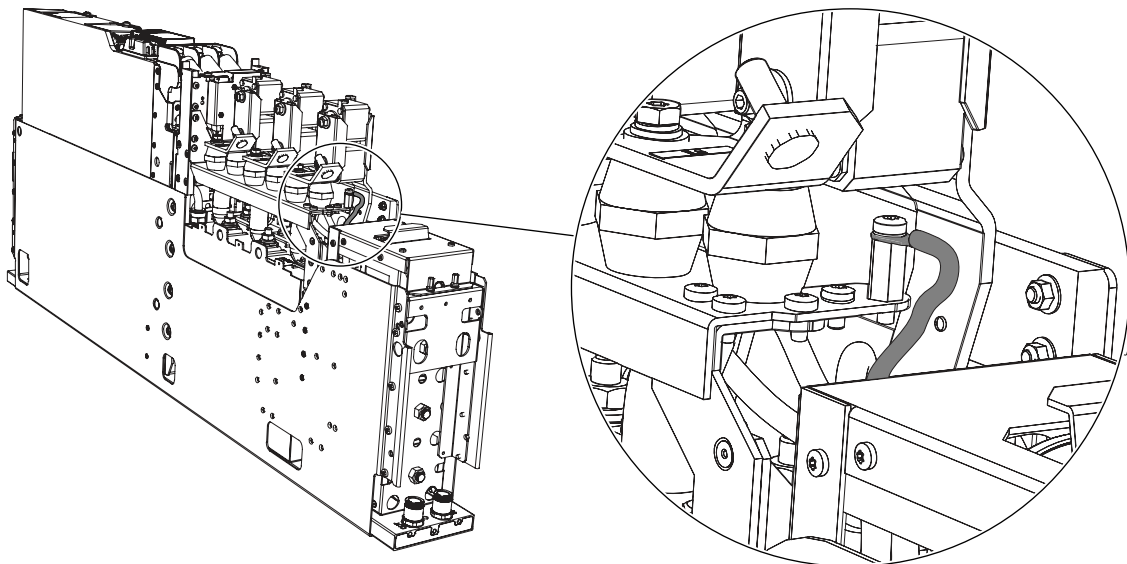

e30bh791.10

Figure 99: Level C4

4. After the change, write "The EMC level was changed from C3 to C4", and the date on the "product modified" label. If the label is not yet attached, attach it on the drive near the product label.

7.12.2 Changing the EMC Protection Level, AR12L (+AEZ1/+AEZ3)

In an IT system, to change the EMC protection level of the drive from C3 to C4, disconnect the LC Filter ground capacitor.

Procedure

1. Loosen the screw of the grounding wire of the LC Filter.
2. Remove the grounding wire from the grounding terminal.
3. Move the cable lug of the grounding wire with the screw onto the insulator and tighten the screw (maximum 0.5 Nm (4.4 in-lb)).

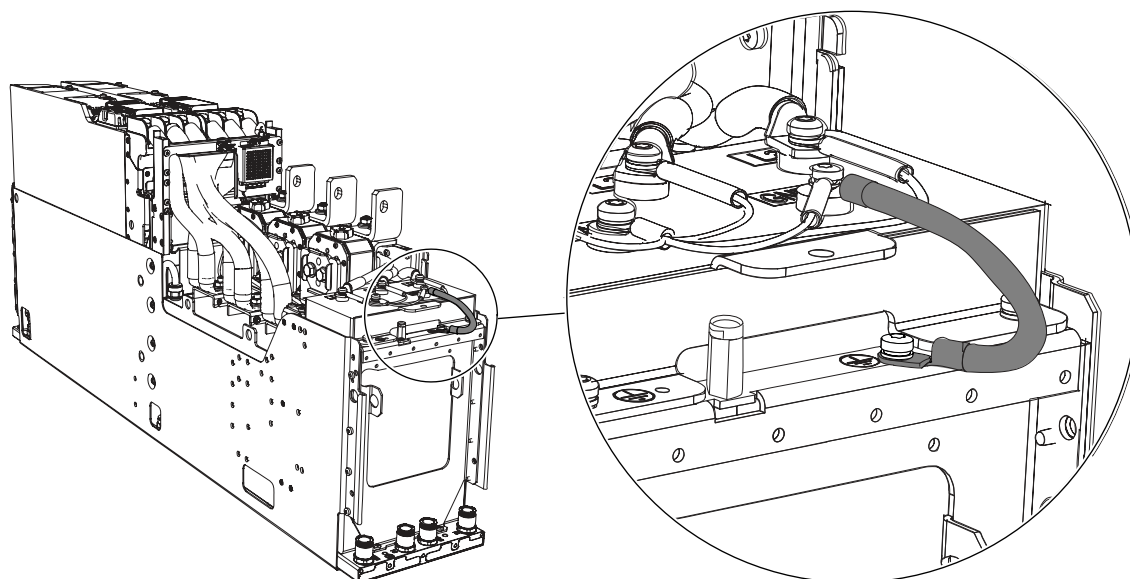

e30bg862.10

Figure 100: Level C3

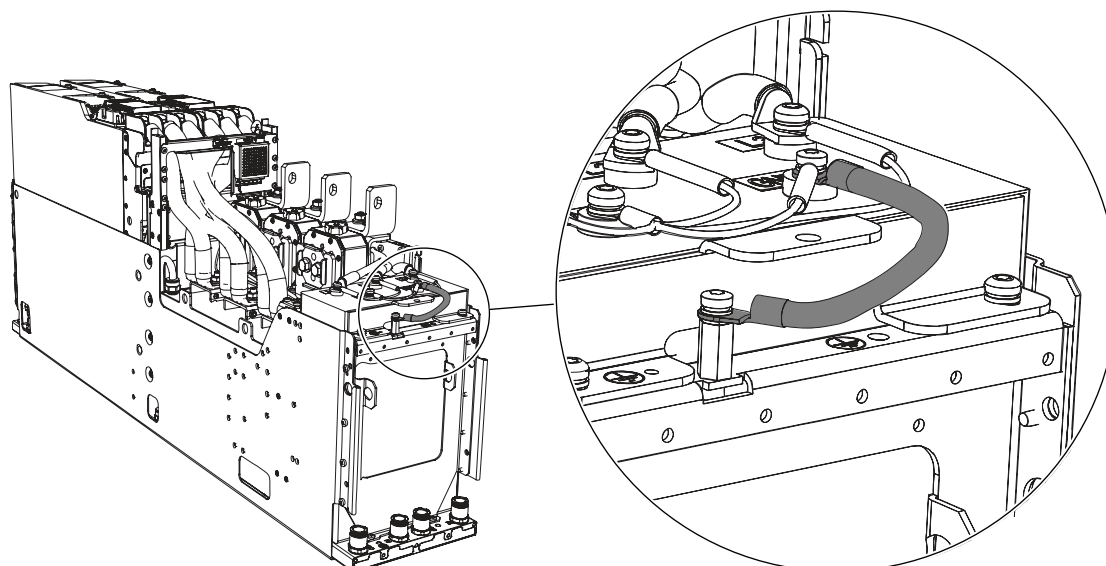

e30bh792.10

Figure 101: Level C4

4. After the change, write "The EMC level was changed from C3 to C4", and the date on the "product modified" label. If the label is not yet attached, attach it on the drive near the product label.

7.12.3 Changing the EMC Protection Level, LC Filter, OF7Z1, OF7SI2, OF7SI4, Size LC10L

In an IT system, to change the EMC protection level of the drive from C3 to C4, disconnect the LC Filter ground capacitor.

Procedure

1. Loosen the screw of the grounding wire of the LC Filter.
2. Remove the grounding wire from the grounding terminal.
3. Move the cable lug of the grounding wire with the screw onto the insulator and tighten the screw (maximum 0.5 Nm (4.4 in-lb)).

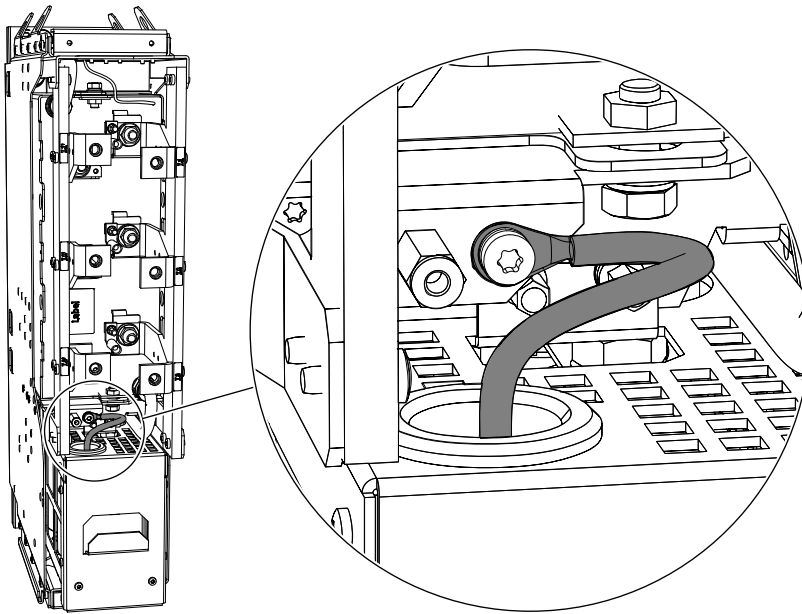

e30bh793.11

Figure 102: Level C3

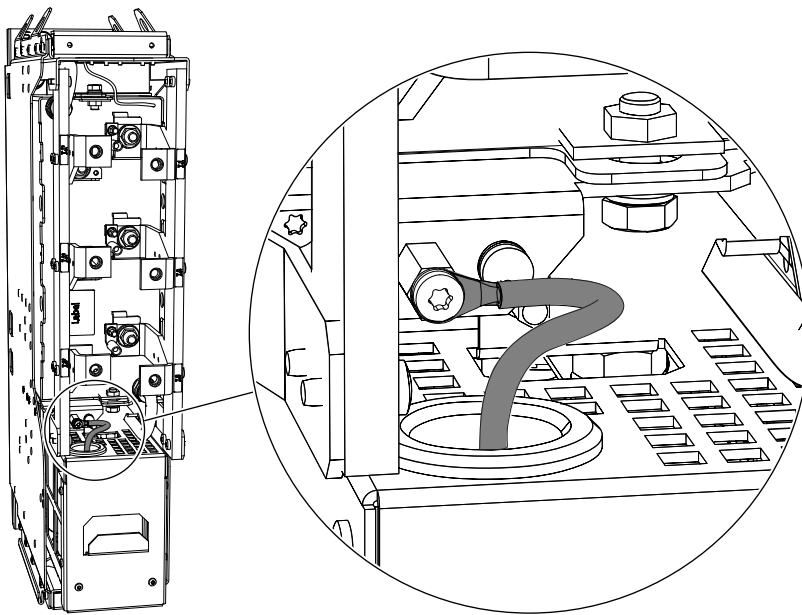

e30bh651.11

Figure 103: Level C4

4. After the change, write "The EMC level was changed from C3 to C4", and the date on the "product modified" label. If the label is not yet attached, attach it on the drive near the product label.

7.12.4 Changing the EMC Protection Level, LC Filter, OF7Z1, OF7SI2, OF7SI4, Size LC12L

In an IT system, to change the EMC protection level of the drive from C3 to C4, disconnect the LC Filter ground capacitor.

Procedure

1. Loosen the screw of the grounding wire of the LC Filter.
2. Remove the grounding wire from the grounding terminal.
3. Move the cable lug of the grounding wire with the screw onto the insulator and tighten the screw (maximum 0.5 Nm (4.4 in-lb)).

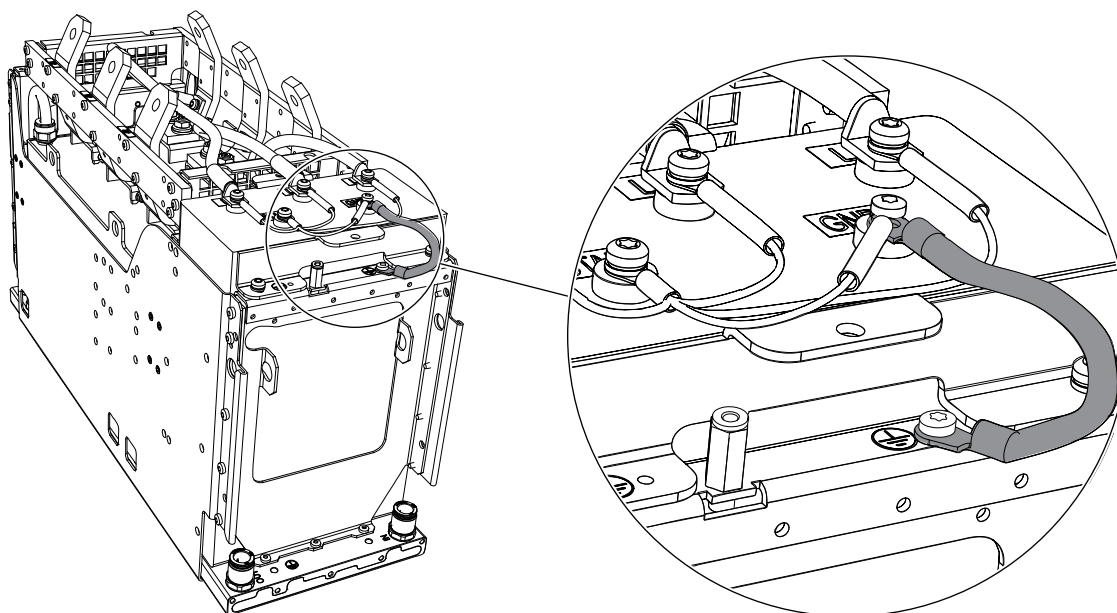

e30bh652.11

Figure 104: Level C3

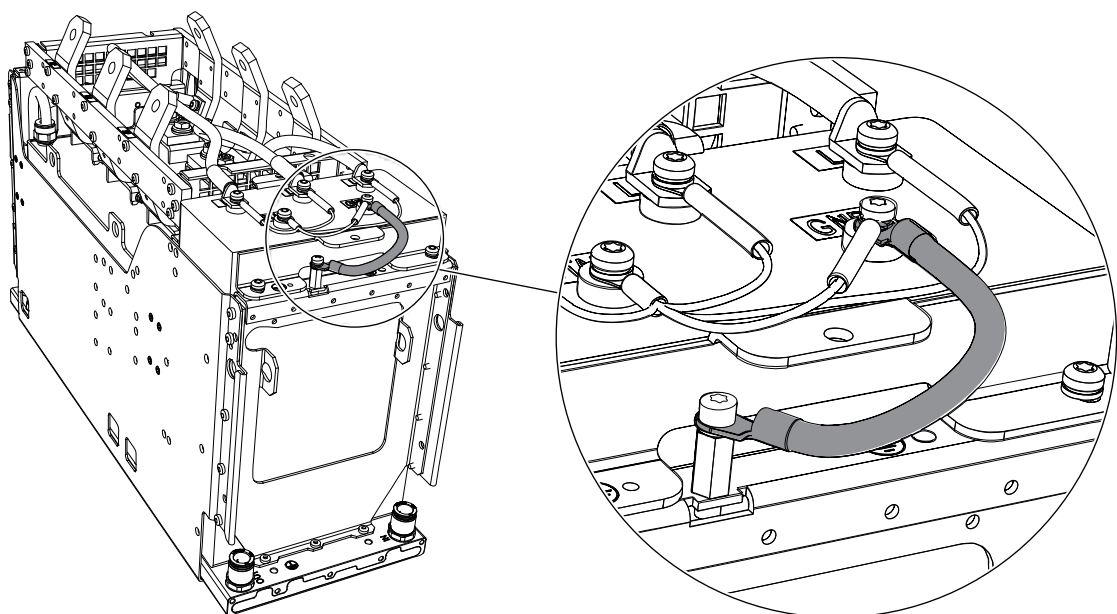

e30bh794.11

Figure 105: Level C4

4. After the change, write "The EMC level was changed from C3 to C4", and the date on the "product modified" label. If the label is not yet attached, attach it on the drive near the product label.

7.13 Filters

7.13.1 dU/dt Filter

The dU/dt Filter is used with the inverter module (INU) in motor or generator drive applications to reduce the peak voltage seen by the electrical machine. With the dU/dt Filter, the nominal switching frequency is 2 kHz with the modulator type 1, or 3 kHz with the modulator type 6. The maximum switching frequency is 4 kHz with the modulator type 1, or 6 kHz with the modulator type 6.

The dU/dt Filter can be used without derating up to 70 Hz. For output frequencies higher than 70 Hz, current must be derated according to the curve shown in [Figure 106](#). Above 200 Hz, a special high-speed filter is recommended.

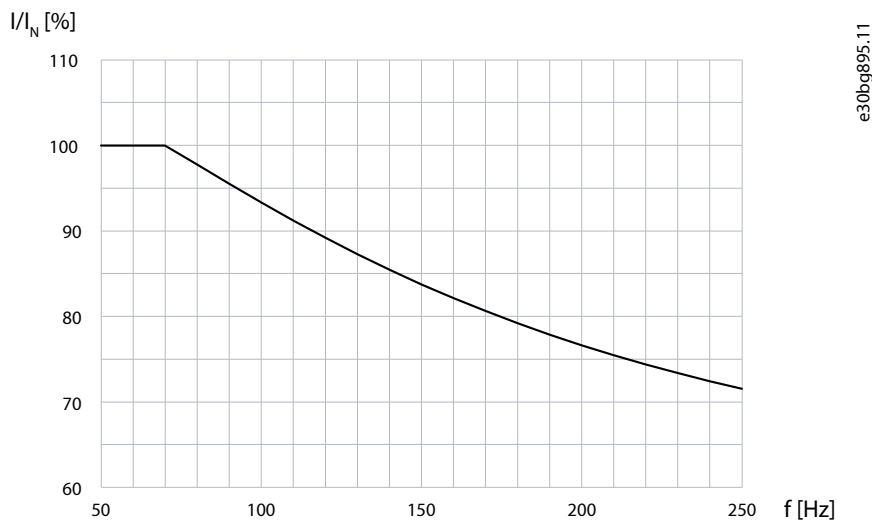

Figure 106: Output Frequency Derating

Maximum motor cable length depends mainly on switching frequency, DC-link voltage, and motor cable setup. Safe operation area graphs are shown in the following figures for all available filter types. The motor cable length is based on the maximum number of cables for each frame (see [10.4.8 Field Cable Sizes for INU Module, 380–500 V AC](#) or [10.4.9 Field Cable Sizes for INU Module, 525–690 V AC](#)). For example, the graphs for a 416 A filter are based on 2 parallel cables, and for an 820 A filter on 4 parallel cables. The default motor cable operating capacitance is 0.75 nF/m. If some other cable type is used or the number of cables connected in parallel does not match with recommendations, the maximum motor cable length must be derated so that the maximum total motor cable capacitance is not exceeded.

Losses are higher in the low output frequency range (0–5 Hz). If drives are operating in this range, the maximum motor cable length (capacitance) must be derated.

In an IT system, filter losses in a single-phase ground fault depend on the setup. To minimize the earth fault current, minimize all capacitances to the ground. The fault current increases the losses, and continuous operation during the ground fault cannot be guaranteed, especially if the filter is already in the limits without the fault. The filter has temperature protection in every phase to protect the filter against too high ground fault currents. If continuous operation during a single-phase ground fault is a strict requirement, a sine-wave filter is recommended.

! IMPORTANT: [Table 12](#) and [Table 13](#) describe the liquid flow rate values in coolant temperatures 35–45 °C (95–113 °F). If the coolant temperature is lower than normal, it is possible to decrease the flow rate, but a smaller flow limits the maximum length of the motor cables. The limitations can be seen in the following graphs.

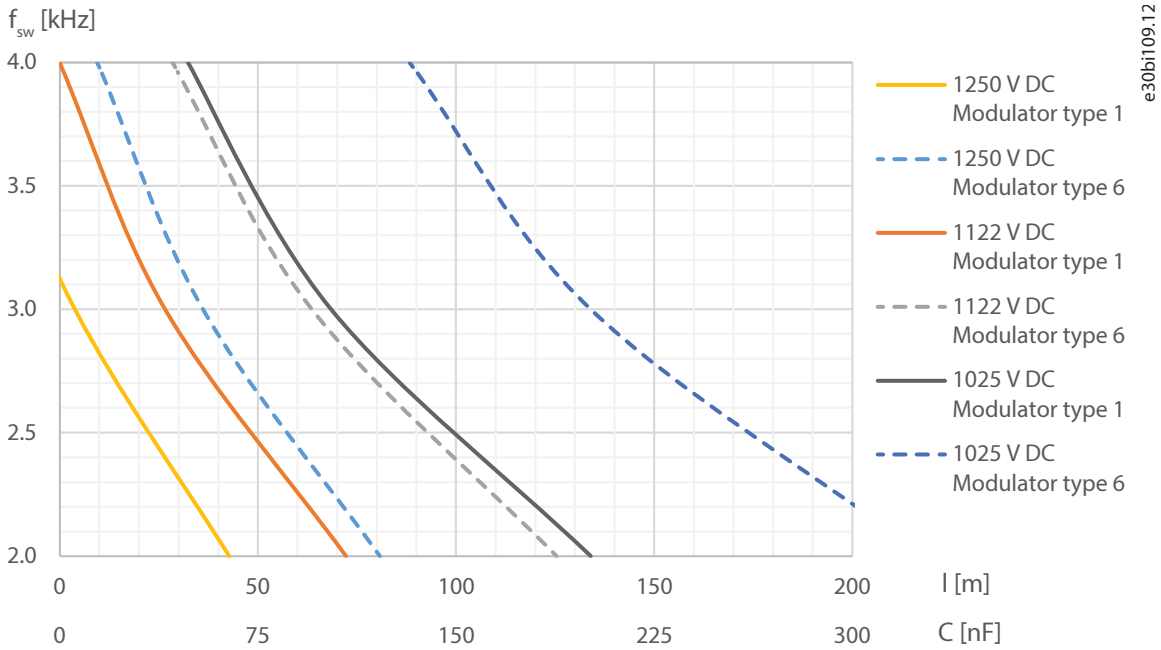

Figure 107: Safe Operation Area: 690 V AC 416 A dU/dt Filter, 100% Flow

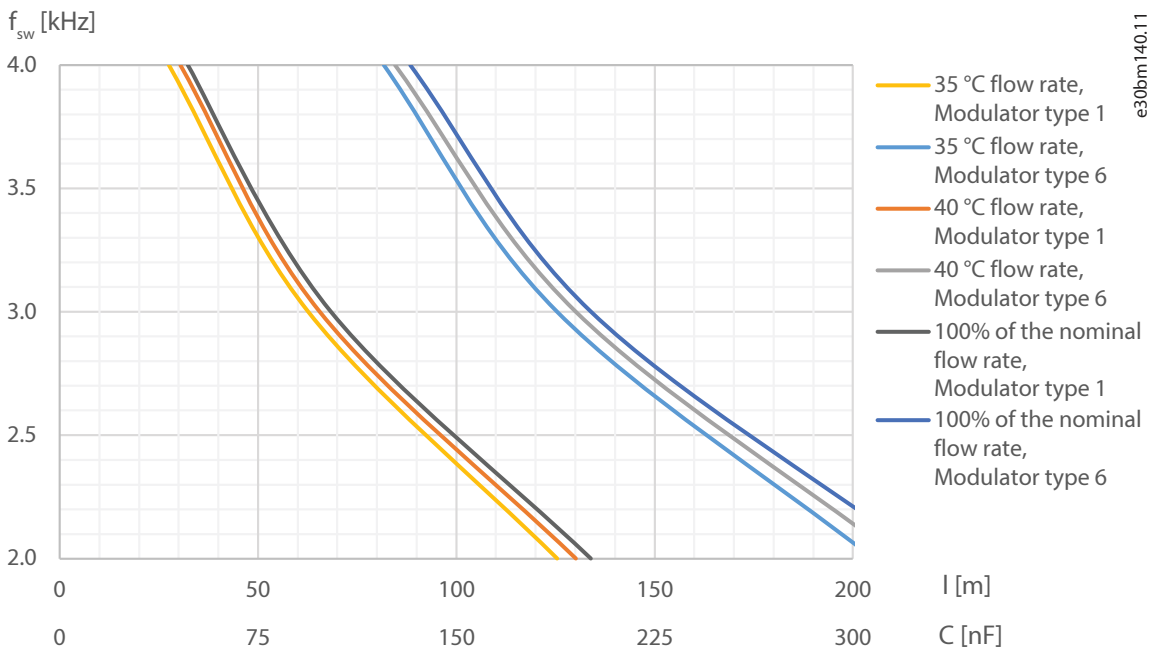

Figure 108: Safe Operation Area with Different Flow Rates: 416 A dU/dt Filter, 1025 V DC

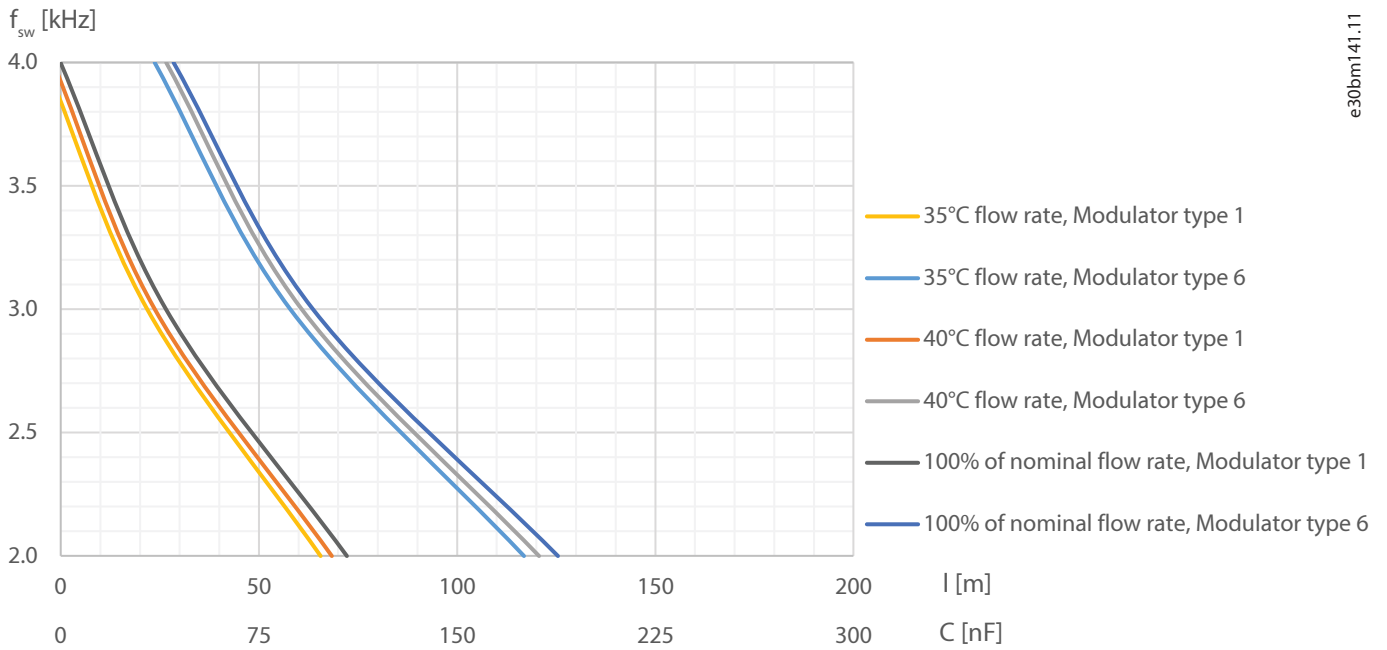

Figure 109: Safe Operation Area with Different Flow Rates: 416 A dU/dt Filter, 1122 V DC

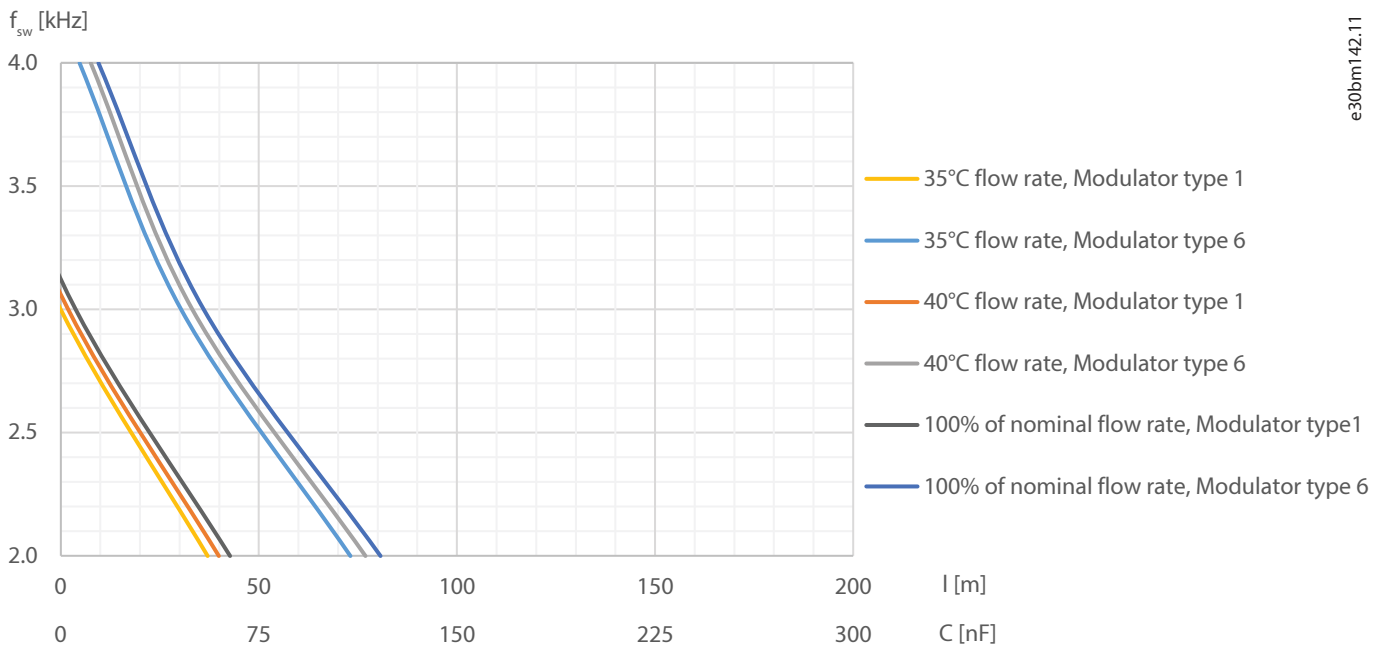
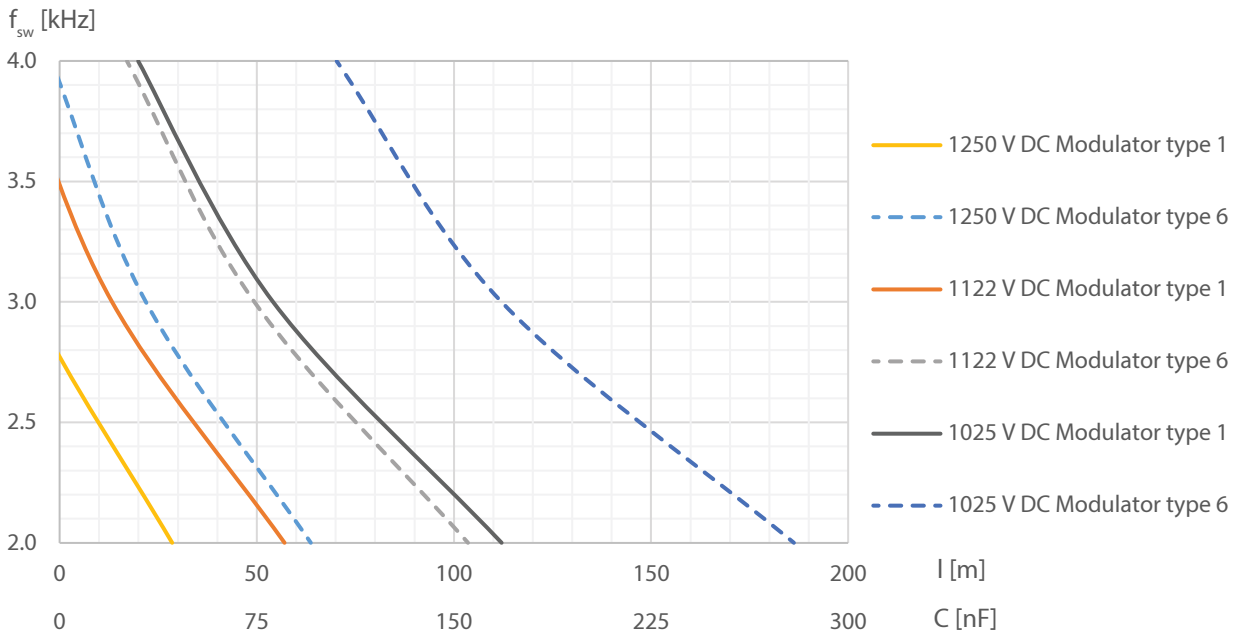
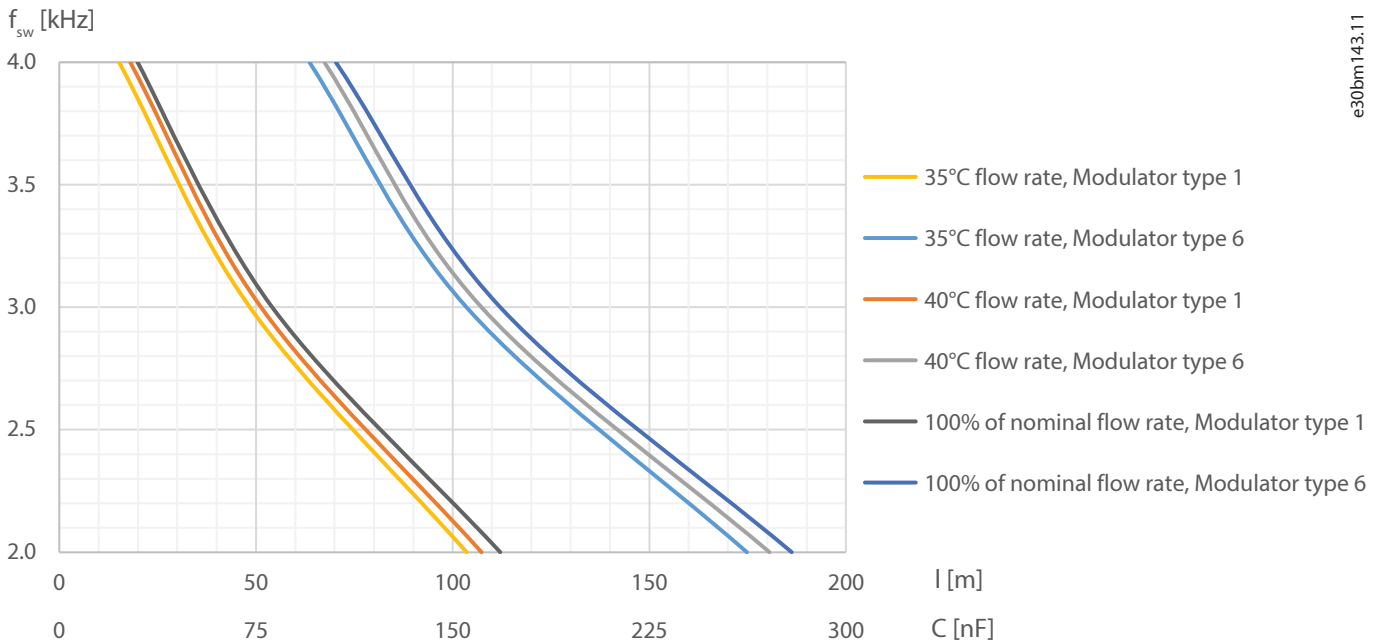

Figure 110: Safe Operation Area with Different Flow Rates: 416 A dU/dt Filter, 1250 V DC



e30bi110.12

Figure 111: Safe Operation Area: 690 V AC 416 A dU/dt Filter, Low Output Frequency Range, 100% Flow



e30bm143.11

Figure 112: Safe Operation Area with Different Flow Rates: 416 A dU/dt Filter, Low Output Frequency Range, 1025 V DC

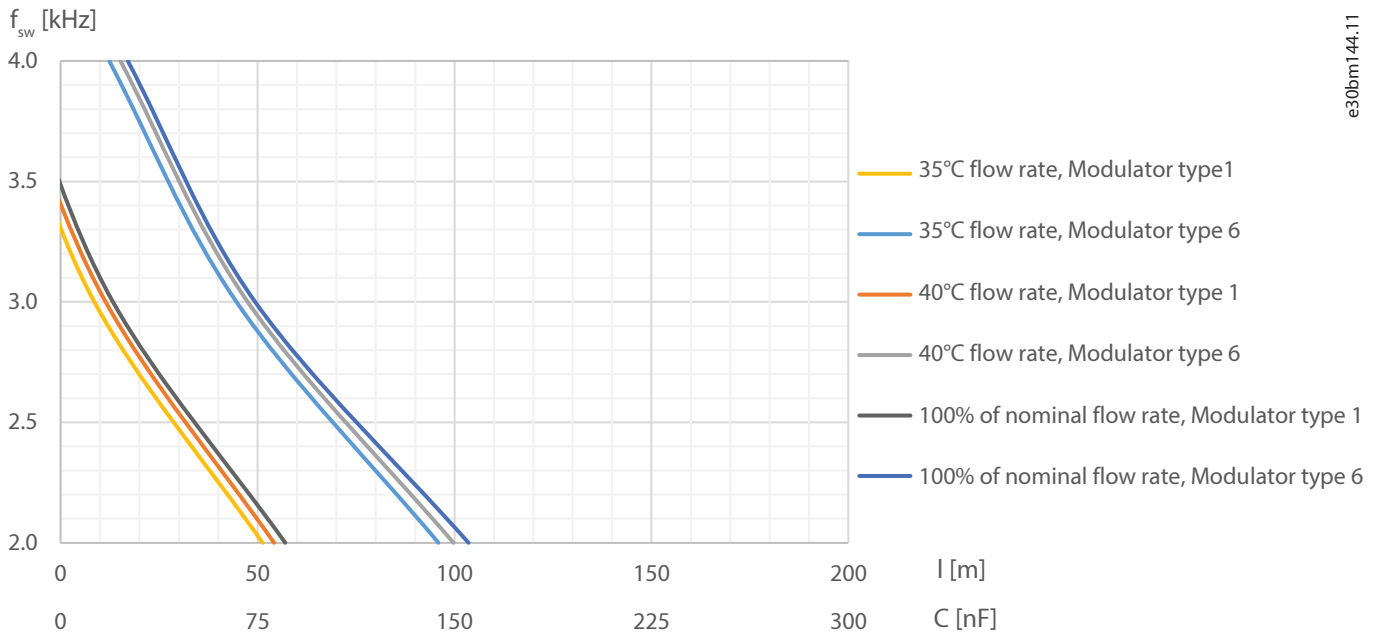

Figure 113: Safe Operation Area with Different Flow Rates: 416 A dU/dt Filter, Low Output Frequency Range, 1122 V DC

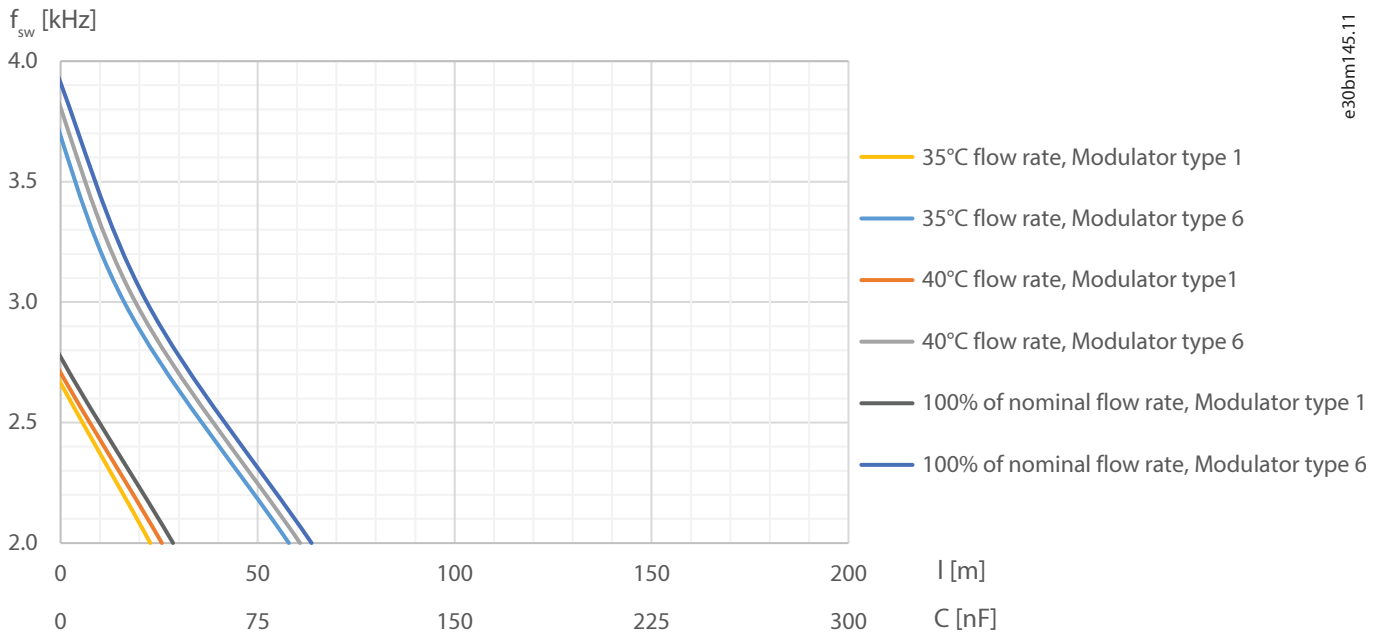
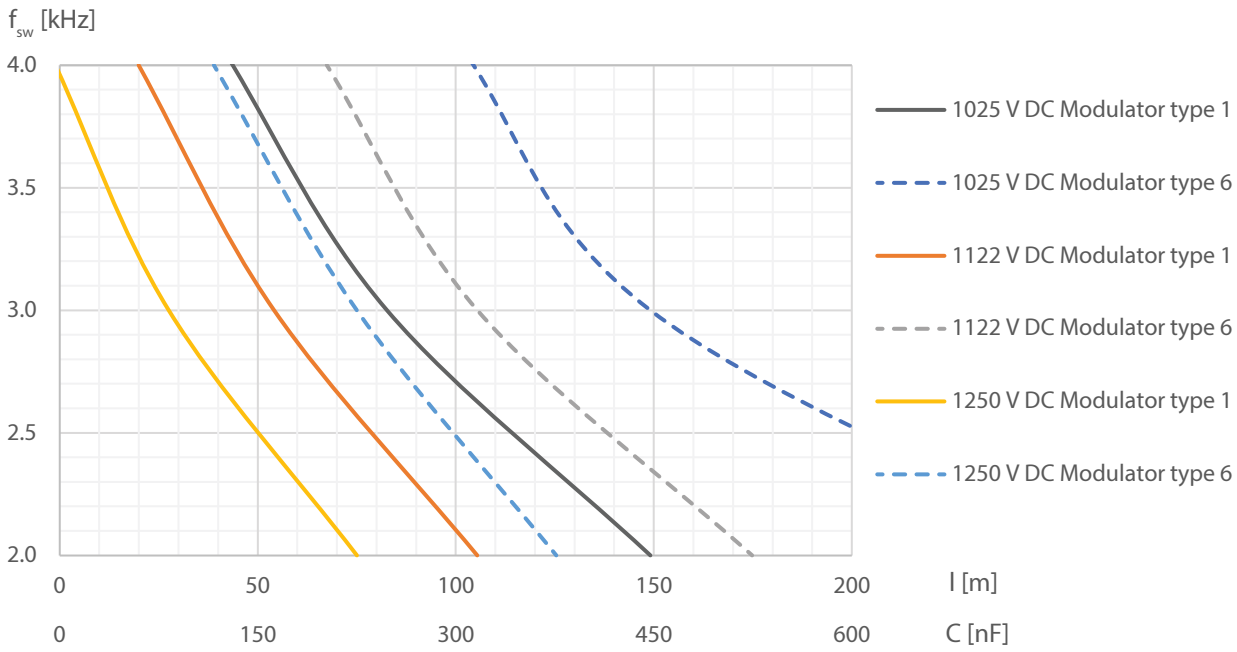
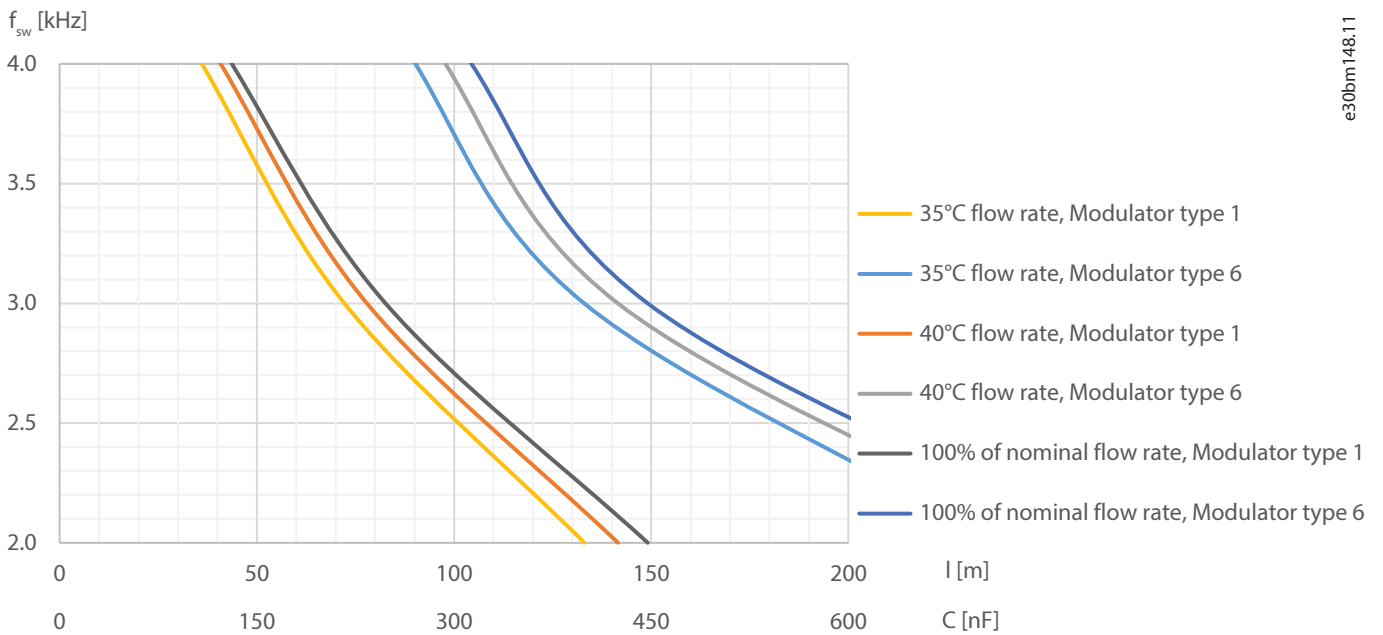

Figure 114: Safe Operation Area with Different Flow Rates: 416 A dU/dt Filter, Low Output Frequency Range, 1250 V DC



e30br113.12

Figure 115: Safe Operation Area: 690 V AC 820 A dU/dt Filter, 100% Flow



e30br148.11

Figure 116: Safe Operation Area with Different Flow Rates: 820 A dU/dt Filter, 1025 V DC

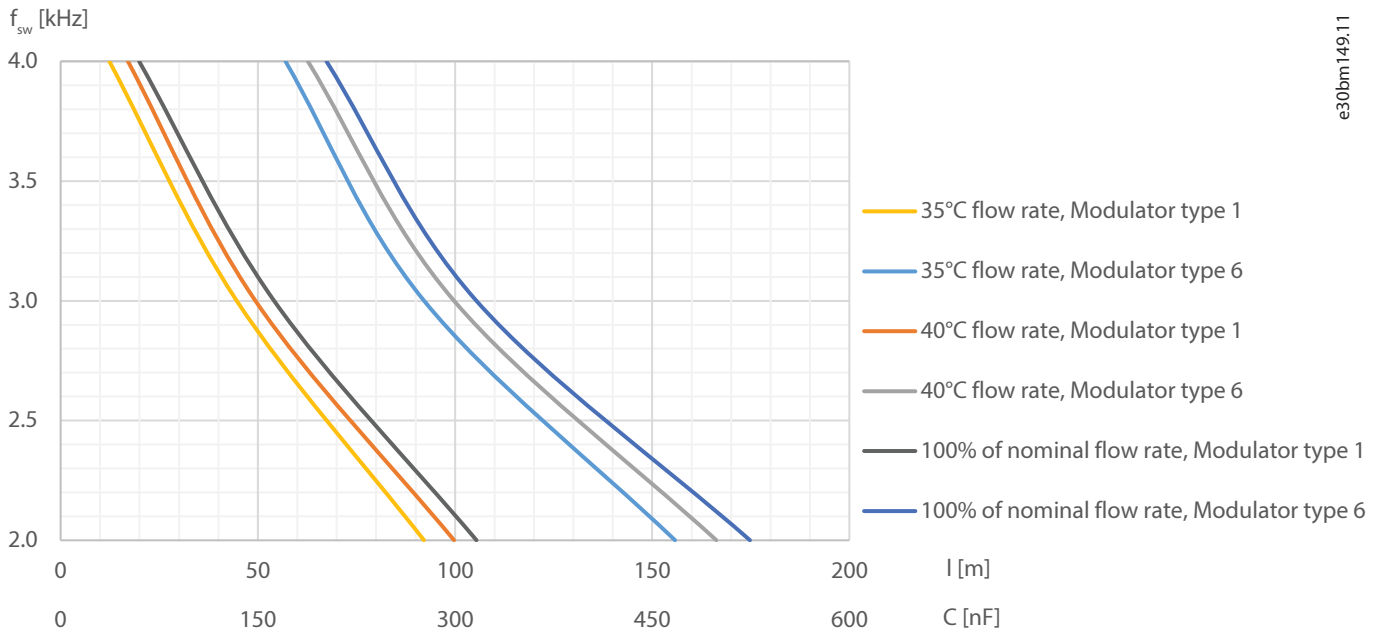

e30bm149.11

Figure 117: Safe Operation Area with Different Flow Rates: 820 A dU/dt Filter, 1122 V DC

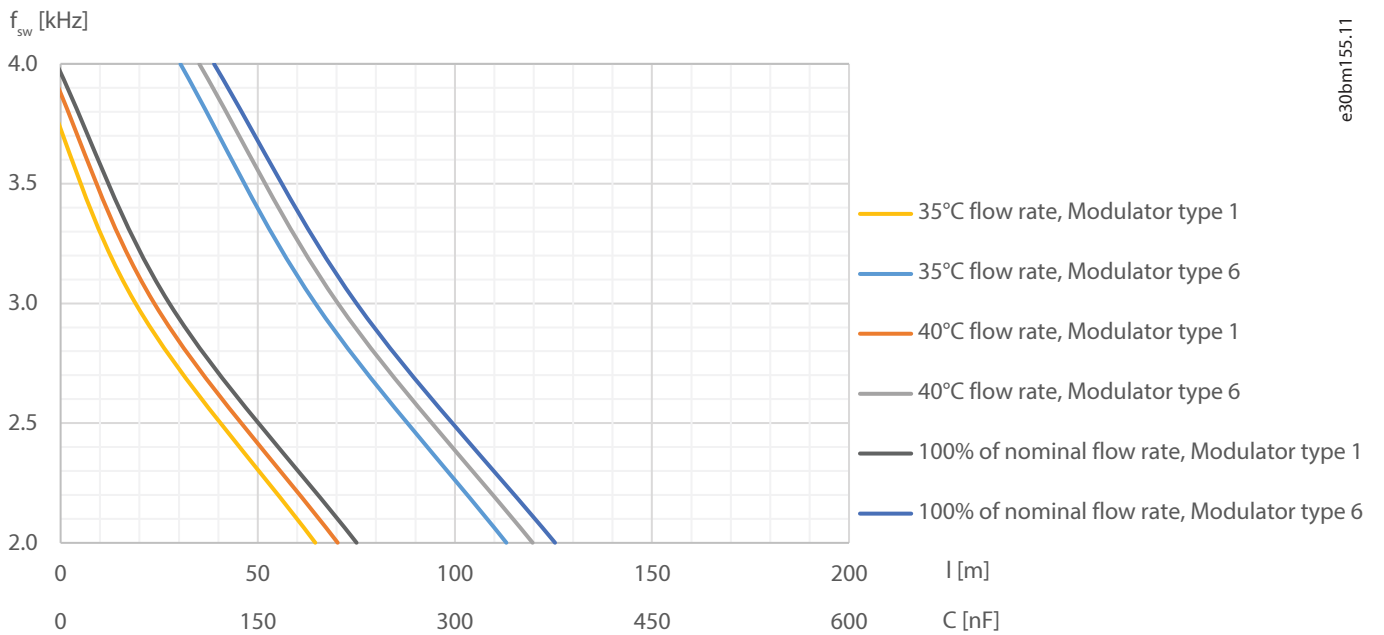

e30bm155.11

Figure 118: Safe Operation Area with Different Flow Rates: 820 A dU/dt Filter, 1250 V DC

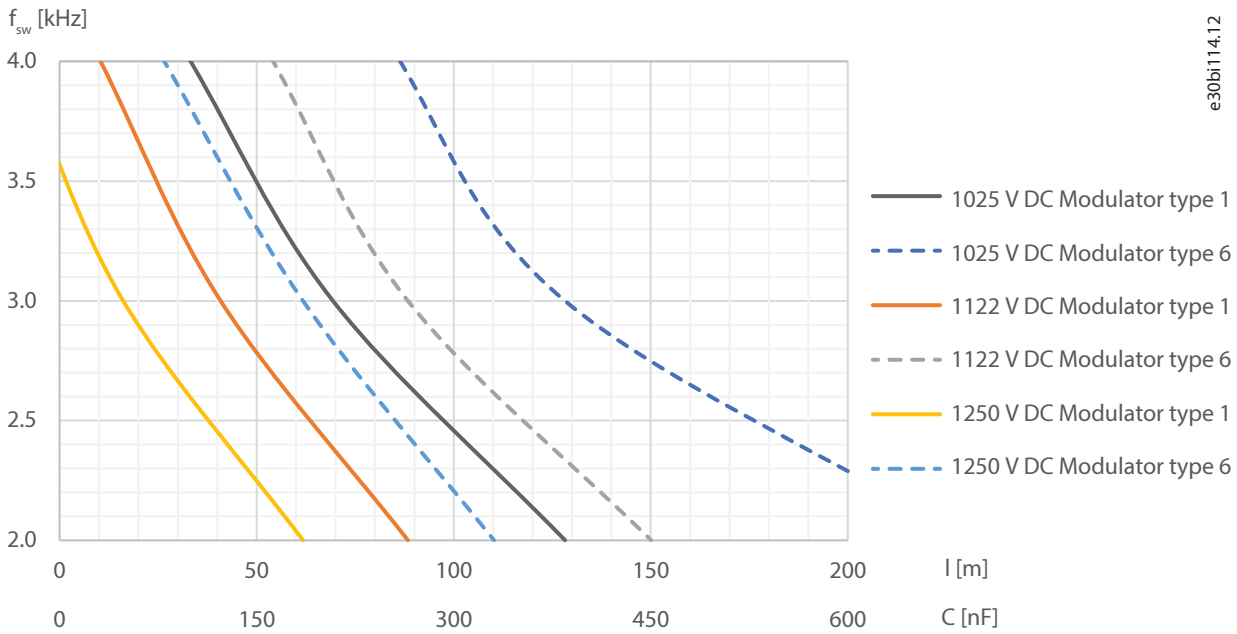

e30bi114.12

Figure 119: Safe Operation Area: 690 V AC 820 A dU/dt Filter, Low Output Frequency Range, 100% Flow

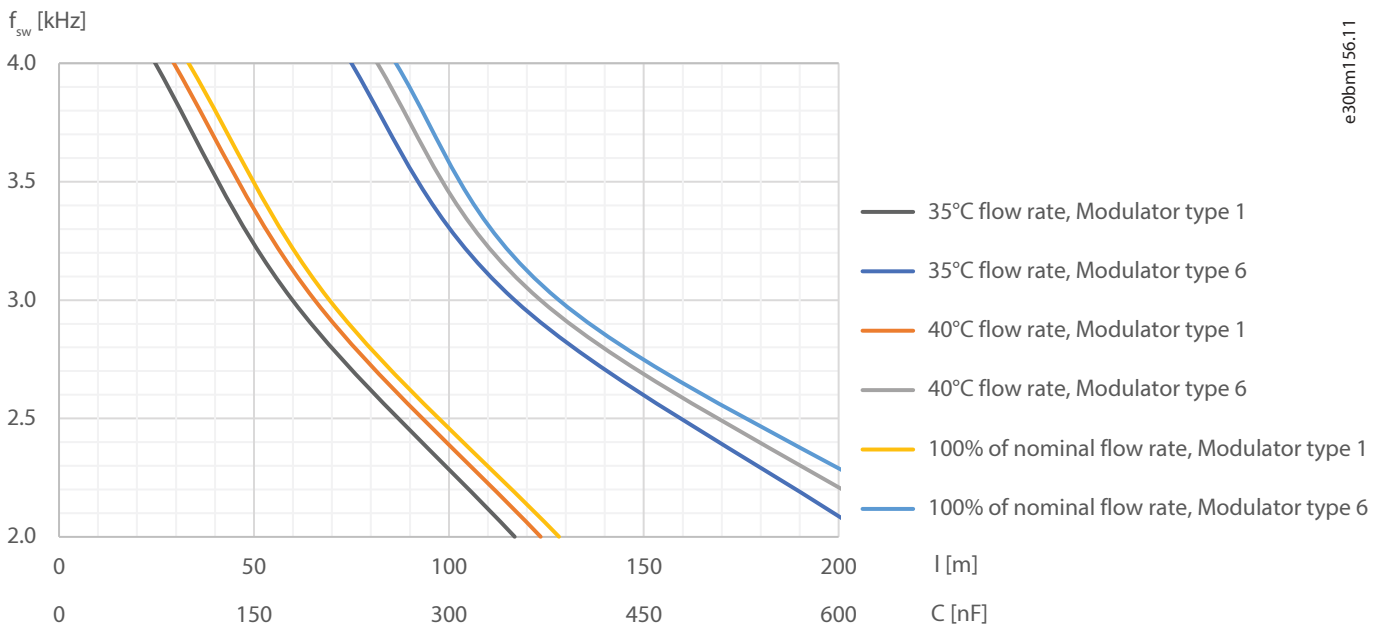

e30bmi56.11

Figure 120: Safe Operation Area with Different Flow Rates: 820 A dU/dt Filter, Low Output Frequency Range, 1025 V DC

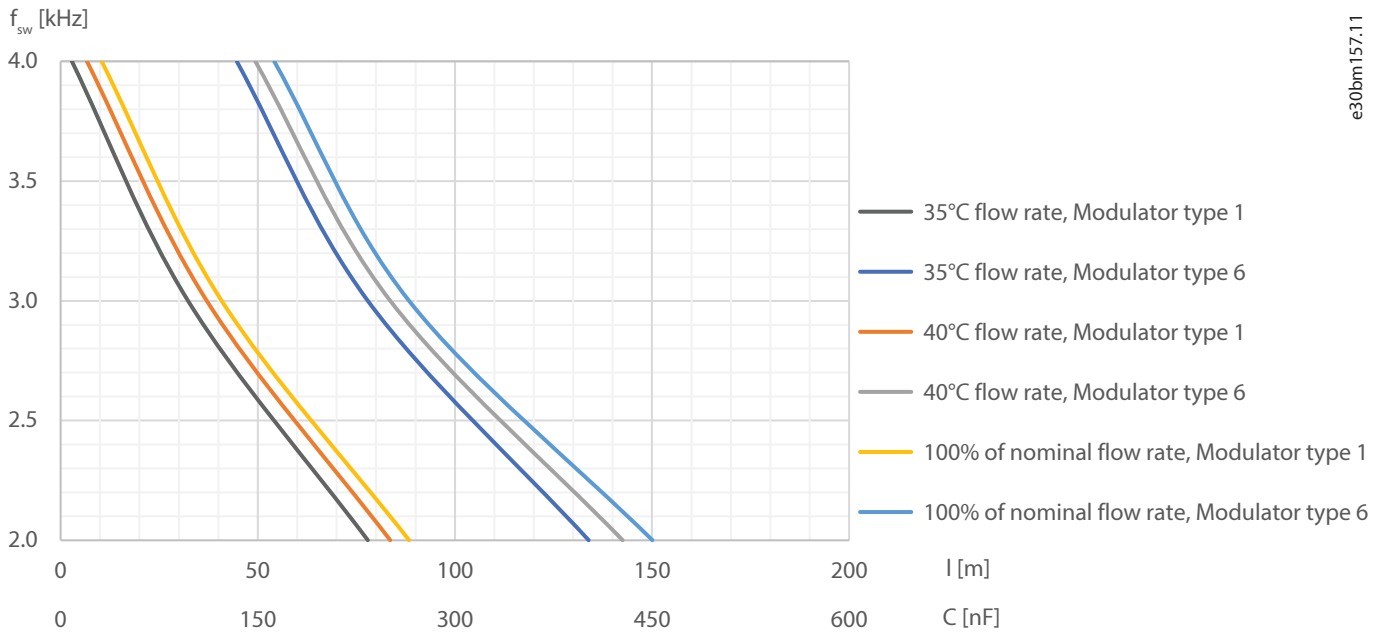

e30bm157.11

Figure 121: Safe Operation Area with Different Flow Rates: 820 A dU/dt Filter, Low Output Frequency Range, 1122 V DC

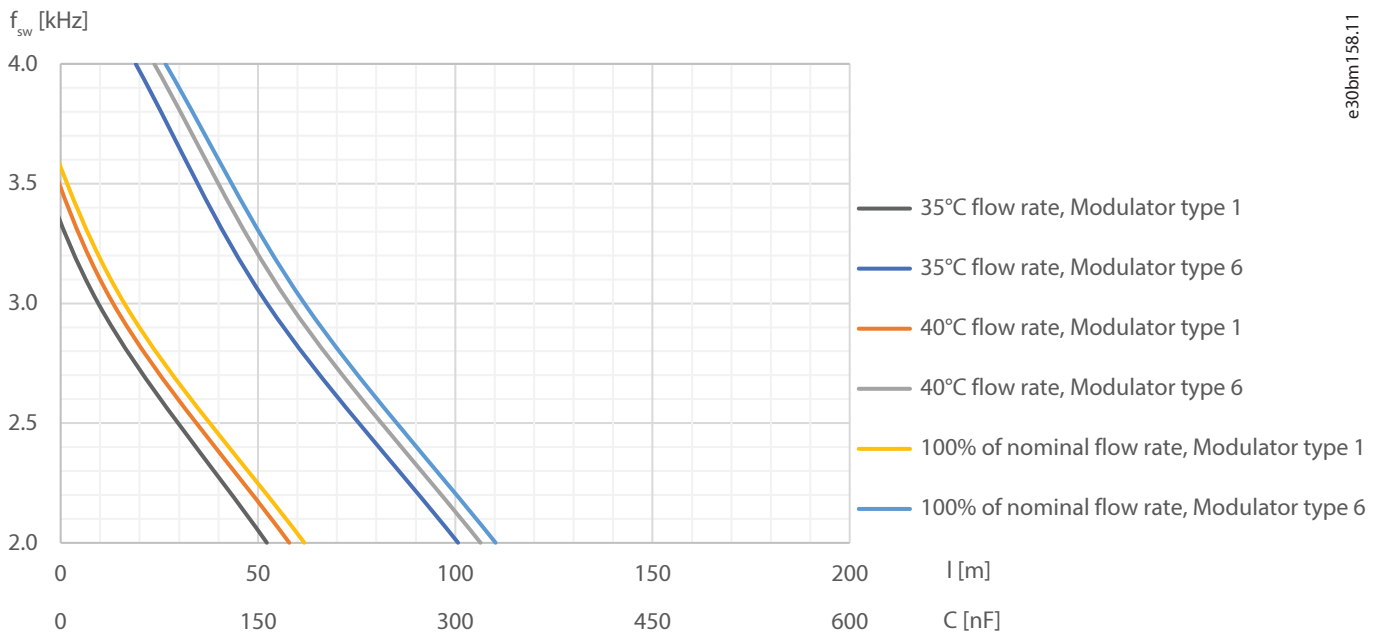

e30bm158.11

Figure 122: Safe Operation Area with Different Flow Rates: 820 A dU/dt Filter, Low Output Frequency Range, 1250 V DC

7.13.2 Common-mode Filter

The inverter unit (INU) in frames IM10L and IR10L is available with and without additional common-mode filtering together with the dU/dt Filter. With the Common-mode Filter, the nominal switching frequency is 2 kHz with the modulator type 1, or 3 kHz with the modulator type 6. The maximum switching frequency is 4 kHz with the modulator type 1, or 6 kHz with the modulator type 6.

The Common-mode Filter can operate in the whole output frequency range of the drive.

The maximum motor cable length depends mainly on switching frequency, DC-link voltage, and motor cable setup. Safe operation area graphs are shown in the following figures for all available filter types. The motor cable length is based on the maximum number of cables for each frame (see [10.4.9 Field Cable Sizes for INU Module, 525–690 V AC](#)). For example, the graphs for a 416 A filter are based on

2 parallel cables, and for an 820 A filter on 4 parallel cables. The default motor cable operating capacitance is 0.75 nF/m. If some other cable type is used or the number of cables connected in parallel does not match with recommendations, the maximum motor cable length must be derated so that the maximum total motor cable capacitance is not exceeded.

Losses are higher in the low output frequency range (0–5 Hz). If drives are operating in this range, the maximum motor cable length (capacitance) must be derated.

In an IT system, filter losses in a single-phase ground fault depend on the setup. To minimize the ground fault current, minimize all capacitances to the ground. The fault current increases the losses, and continuous operation during the ground fault cannot be guaranteed, especially if the filter is already in the limits without the fault. The filter has temperature protection against too high ground fault currents.

! IMPORTANT: [Table 12](#) and [Table 13](#) describe the liquid flow rate values in coolant temperatures 35–45 °C (95–113 °F). If the coolant temperature is lower than normal, it is possible to decrease the flow rate, but a smaller flow limits the maximum length of the motor cables. The limitations can be seen in the following graphs.

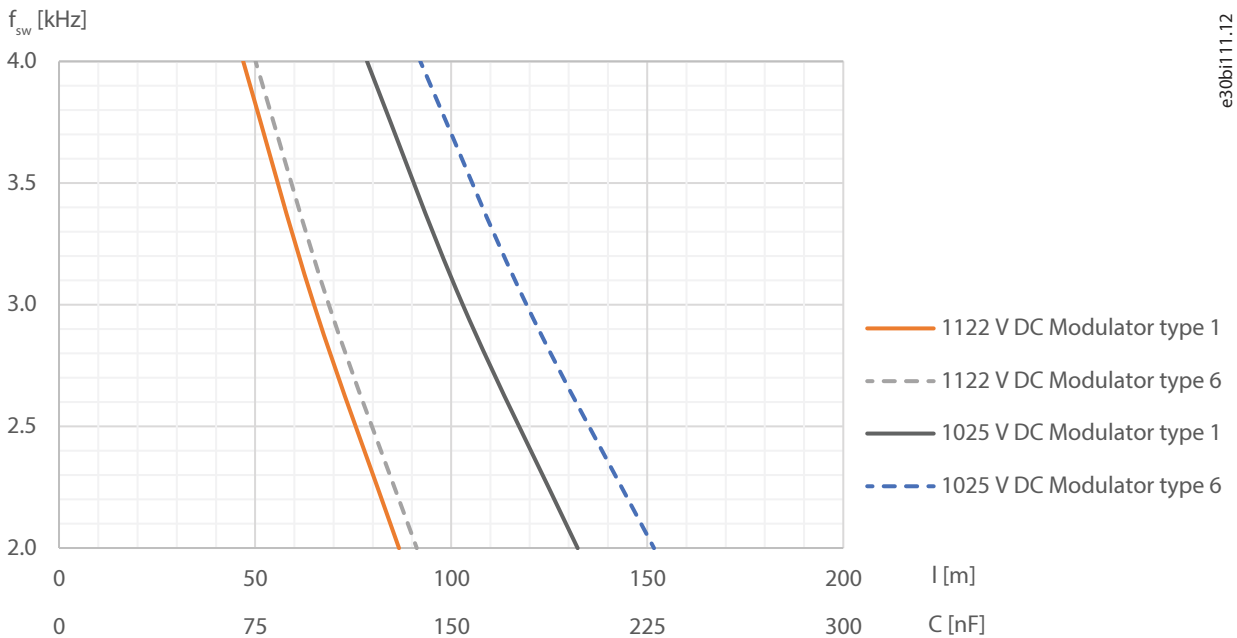
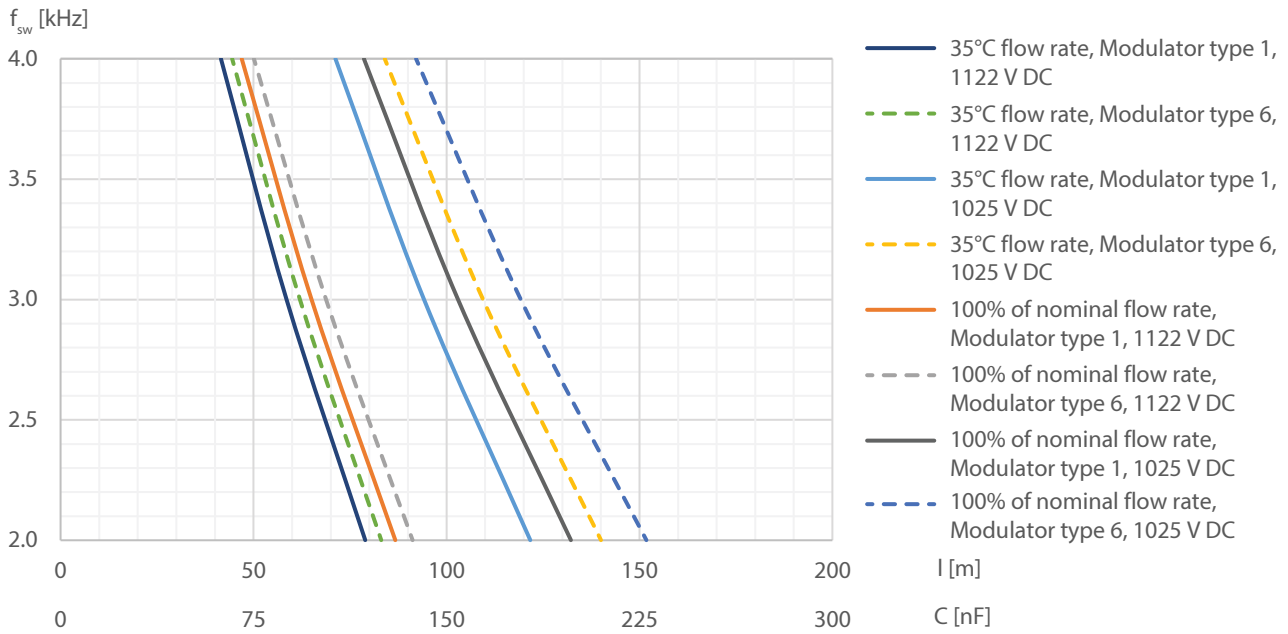
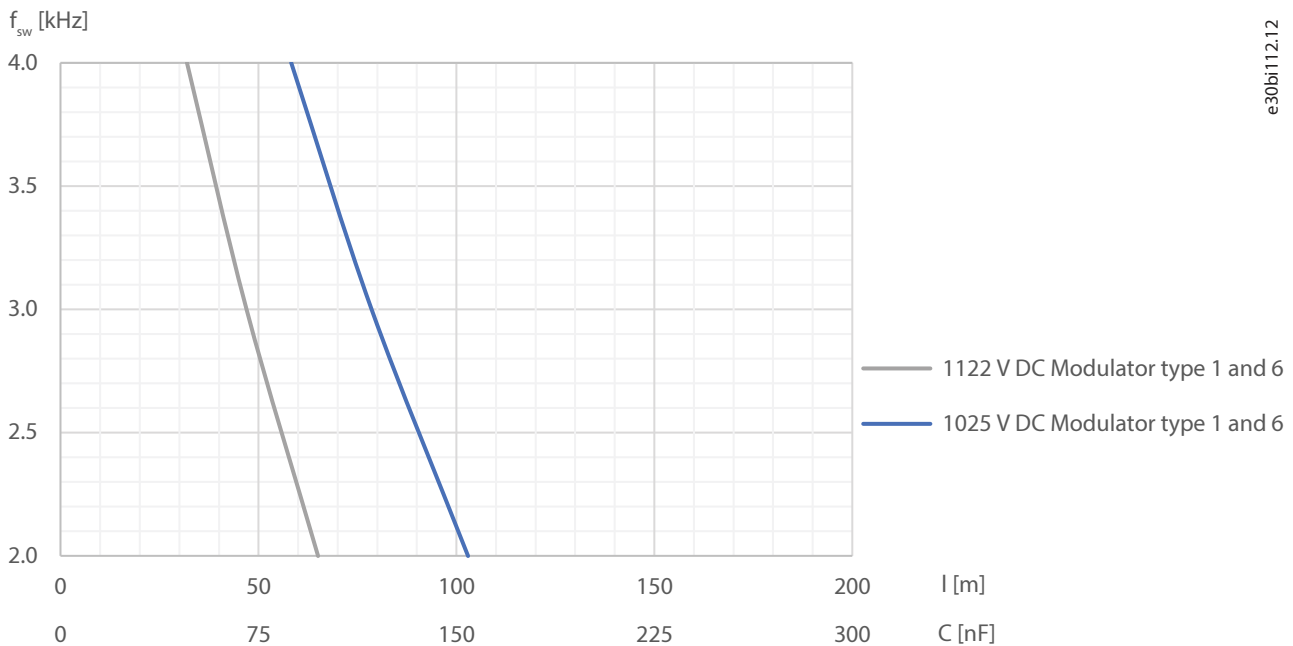

Figure 123: Safe Operation Area: 416 A Common-mode Filter, 100% Flow



e30bm146.11

Figure 124: Safe Operation Area: 416 A Common-mode Filter, with Different Flow Rates



e30bi112.12

Figure 125: Safe Operation Area: 416 A Common-mode Filter, Low Output Frequency Range, 100% Flow

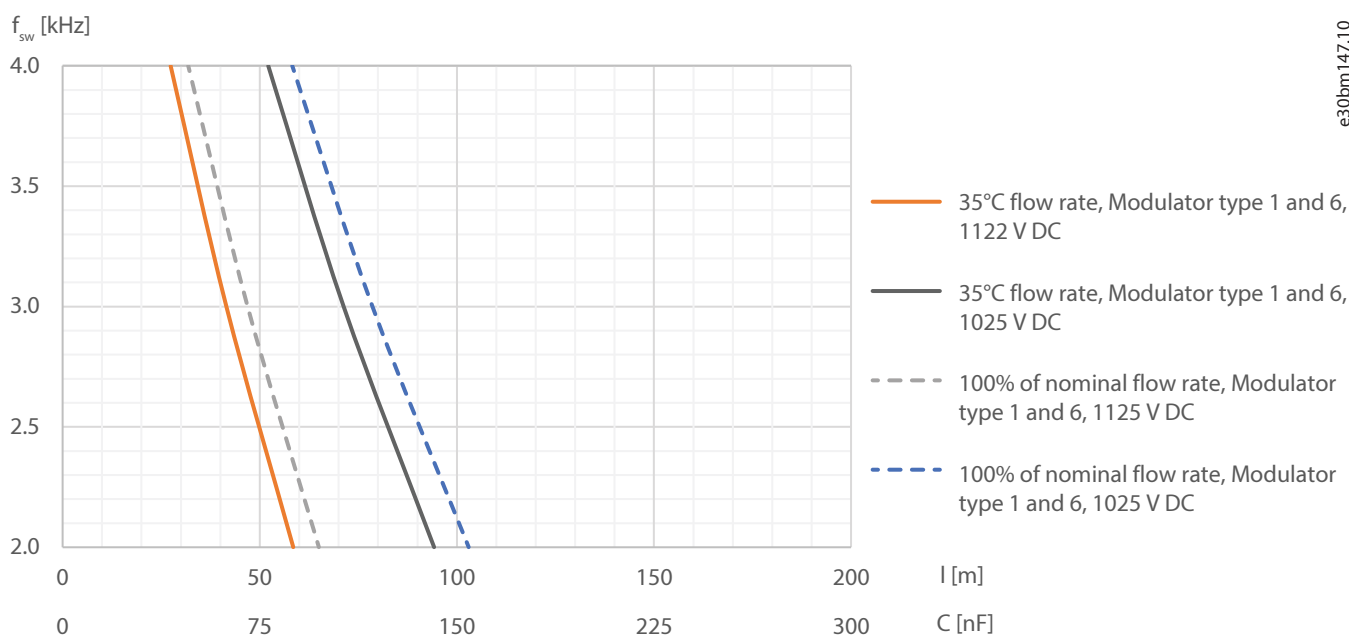

Figure 126: Safe Operation Area: 416 A Common-mode Filter, Low Output Frequency Range, with Different Flow Rates

If drives are connected in parallel, the recommended common connection point for motor cables is at the motor terminals. See [7.6 Prerequisites for Cable Installation](#).

7.13.3 LC Filter

The LC or LCL Filter ensures correct power quality and minimal interruption to the grid, and provides regenerative and low-harmonic functionality. An LC or LCL Filter must be used with the AFE module and the grid converter module between the power supply and the system module. Use the LC Filter when 1 dedicated transformer serves each system module. The LC Filter is designed for the nominal AFE/GC switching frequency. The switching frequency can be adjusted in the window given in [10.8 Technical Data](#). Adjusting the switching frequency can sometimes be useful to avoid system-level resonance frequencies.

NOTICE

Use aR-type AC fuses with the LC Filter. The recommended fuse types can be found in [10.5.1 General Information on the Fuse Tables](#). Select the fuses according to the frame and the current rating of the system module. When designing the fuse installation, refer to [10.3.1 Wiring Diagram, AFE/GC, AR10L and INU +AEZ1, IR10L](#) and [10.3.2 Wiring Diagram, AFE/GC, AR12L and INU +AEZ1, IR12L](#).

7.13.4 Sine-wave Filter

The sine-wave filter is an LC low-pass filter, whose cut-off frequency is set to eliminate all the high-frequency components from the output voltage of the drive. The filter produces a near perfect sinusoidal voltage waveform. The sine-wave filter can be used with an inverter module (INU).

The sine-wave filter reduces bearing currents and eliminates voltage reflections, and it also reduces the noise levels of the motor.

The filter complies with the standard IEC 61800-5-1 and must be used accordingly. The loadability of the filter must be equal to or higher than the rated operating current. At operating frequencies above 70 Hz, current derating must be considered.

There is 1 electrical size of the filter: SIN12L (800 A).

For the current ratings and derating information, see:

- [10.6.20 Current Ratings for the INU with Sine-wave Filter \(+AES1\) \(+AES2\) and LC-filter \(+AEZ1\), 380–500 V AC](#)
- [10.6.21 Current Ratings for the INU with Sine-wave Filter \(+AES1\) \(+AES2\) and LC-filter \(+AEZ\), 600–690 V AC](#)

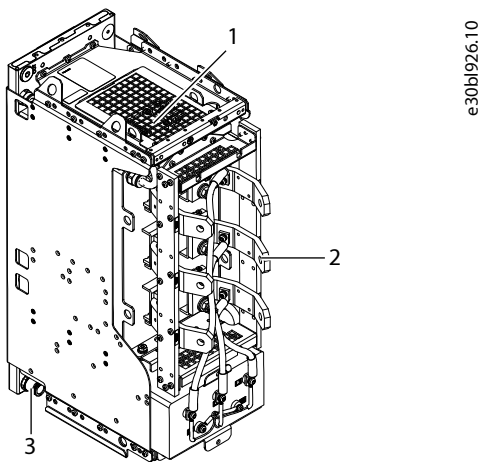

Figure 127: Liquid-cooled Sine-wave Filter

1	AuxBus temperature measurement board	2	Terminals
3	Cooling connectors		

7.13.5 DC Filter

The DC/DC converter requires a DC Filter inductance between the source and the system module for current control and ability to boost voltage. The filter also smoothens the current and voltage waveform, making them suitable for most DC sources or loads.

It is safe to increase the switching frequency which further reduces the current and voltage ripple at the DC source. Decreasing the switching frequency below the nominal value increases the risk of overheating.

The total capacitance of the capacitors in the DC Filter (capacitance between + and - terminals of DC Filter):

- DC Filter, 570 A = 180 μ F
- DC Filter, 1200 A = 480 μ F

NOTICE

Use aR-type DC fuses with the DC Filter. The recommended fuse types can be found in [10.5.12 Source DC+ Fuses for DC/DC Converter, IP00/Open Type](#). Select the fuses according to the frame and the current rating of the system module. When designing the fuse installation, refer to [10.3.7 Wiring Diagram, DC/DC Converter, DR10L](#) and [10.3.8 Wiring Diagram, DC/DC Converter, DR12L](#).

7.13.6 SISO Filter

The iC7 Series Liquid-cooled SISO Filters OF7SI2, OF7SI4, and OF7SO2 are designed to be used with iC7 Series Liquid-cooled System Modules. The SISO (Sine In – Sine Out) input LC and LCL filters (OF7SI2 and OF7SI4) combine both differential (DM) and common-mode (CM) filtering. The DM part of the filter reduces the current distortion as a low-pass filter. The CM part dampens the CM currents and voltages. SISO filters enable installations without a transformer, for example, for marine and energy storage applications.

The SISO output sine-wave filter (OF7SO2) is an LC low pass filter, whose cut-off frequency is set to eliminate all the high-frequency components from the output voltage of the drive. The filter produces a near-perfect sinusoidal voltage waveform. The sine-wave filter reduces bearing currents and eliminates voltage reflections, and it also reduces the noise levels of the motor.

The filter complies with the standard IEC 61800-5-1 and must be used accordingly. The loadability of the filter must be equal to or higher than the rated operating current of the drive.

Table 22: The Available SISO Filters

Filter	Voltage rating	Current rating [A]	Frame designation
SISO input LC filter OF7SI2	380–690 V AC	380	SILC10L
SISO input LC filter OF7SI2	380–690 V AC	760	SILC12L
SISO input LC filter OF7SI2	380–690 V AC	1500	SILC14L
SISO input LCL filter OF7SI4	380–690 V AC	380	SILCL10L
SISO input LCL filter OF7SI4	380–690 V AC	760	SILCL12L
SISO input LCL filter OF7SI4	380–690 V AC	1500	SILCL14L
SISO output sine-wave filter OF7SO2	380–690 V AC	730	SOSIN12L
SISO output sine-wave filter OF7SO2	380–690 V AC	1400	SOSIN14L

7.14 AuxBus Communication

7.14.1 Usage of AuxBus

AuxBus enables communication for filters. When AuxBus is connected, the drive provides temperature monitoring and other diagnostics of the used options thus giving vital information about the system. AuxBus is also used to create warning and fault signals for the system if the drive operates outside the set limits or if there is a failure.

NOTICE

For the drive/converter to be able to protect the filters, AuxBus must be connected.

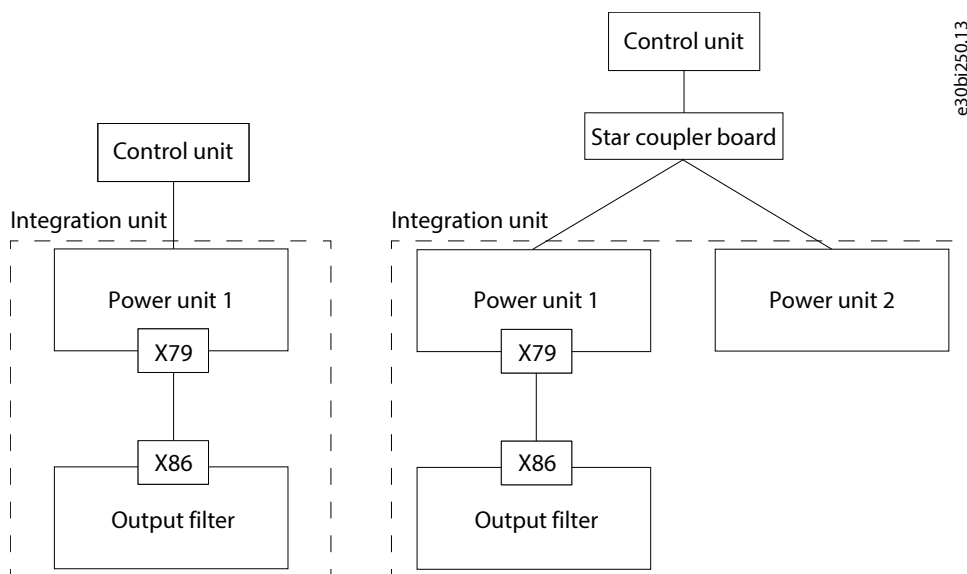

Figure 128: AuxBus Topology for Inverter Modules IR10L and IR12L

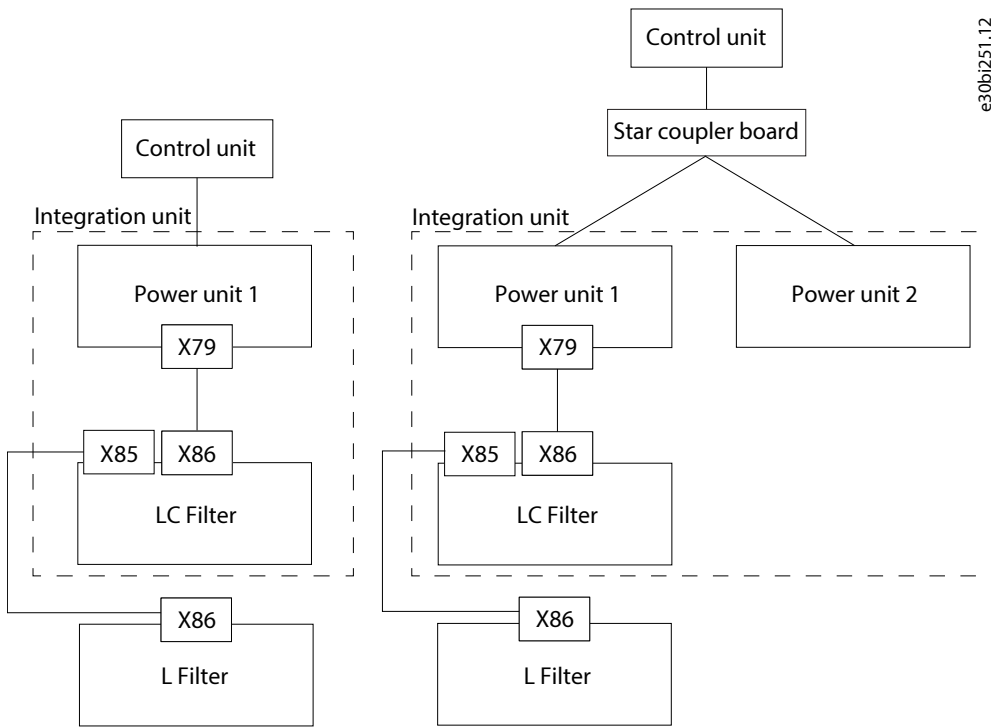

Figure 129: AuxBus Topology for AFE and Grid Converter Modules AR10L and AR12L

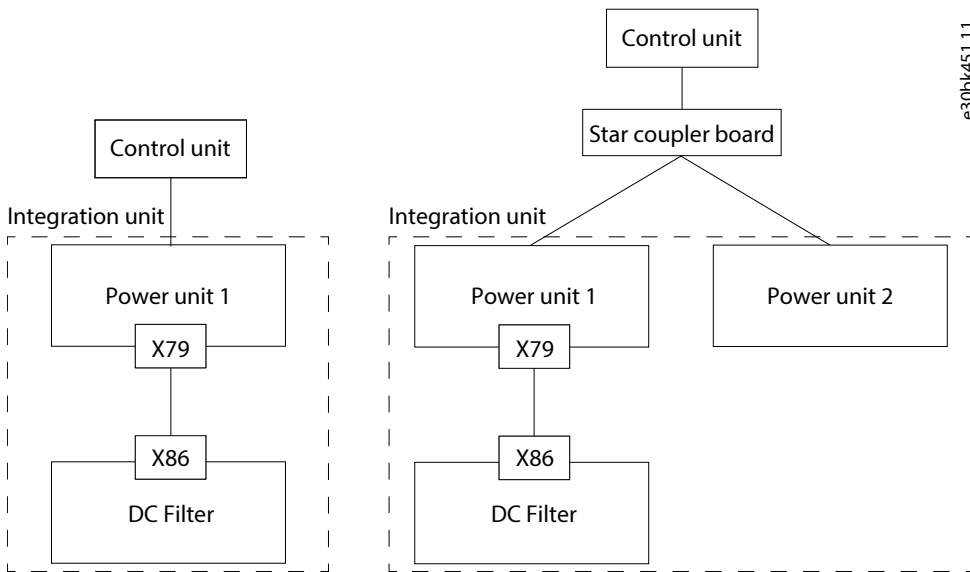
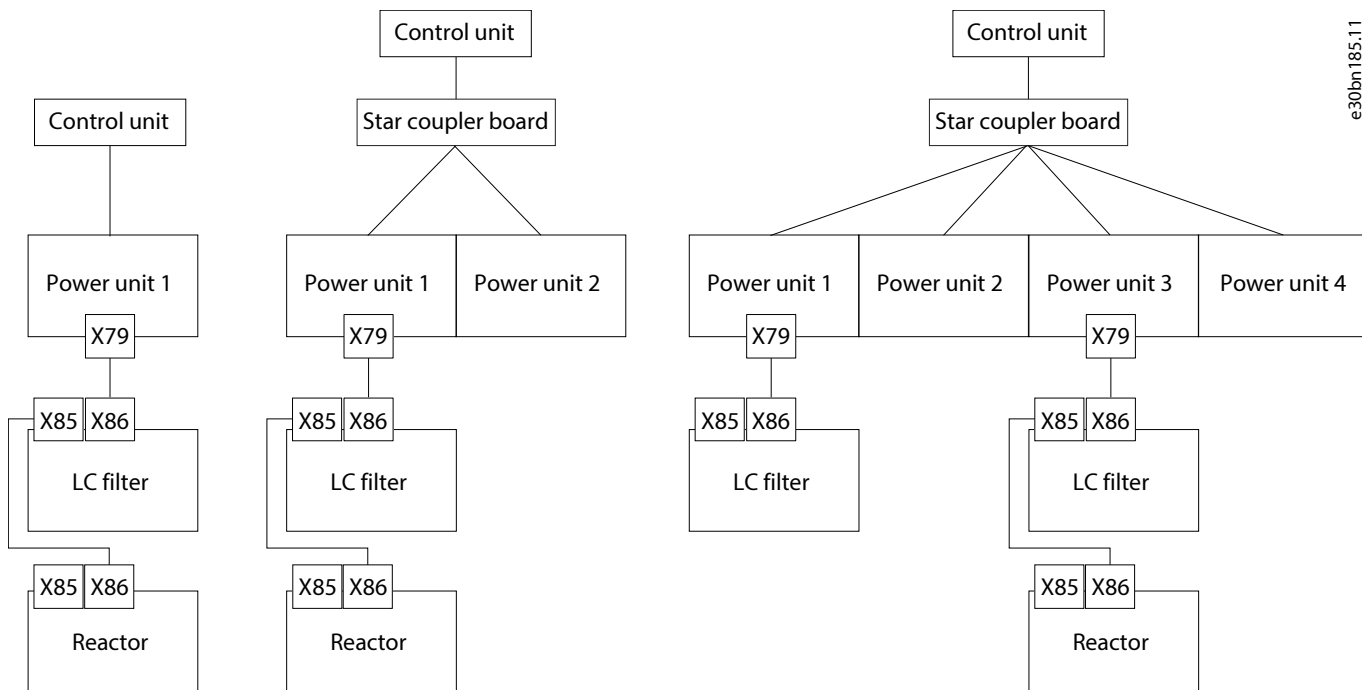

Figure 130: AuxBus Topology for DC/DC Converter Modules DR10L and DR12L

SISO filters



e30bn185.11

Figure 131: AuxBus Topology for OF7S12

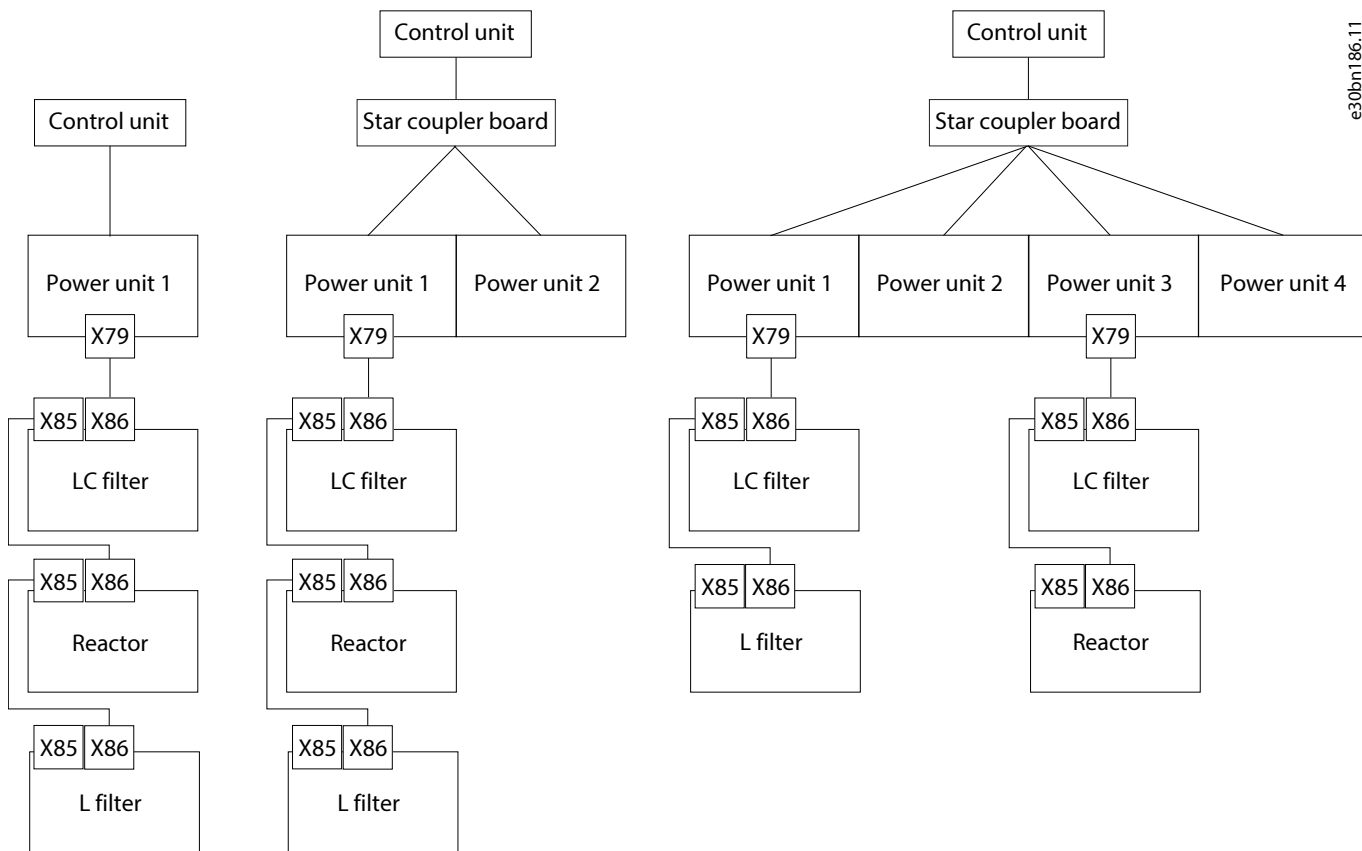

e30bn186.11

Figure 132: AuxBus Topology for OF7S14

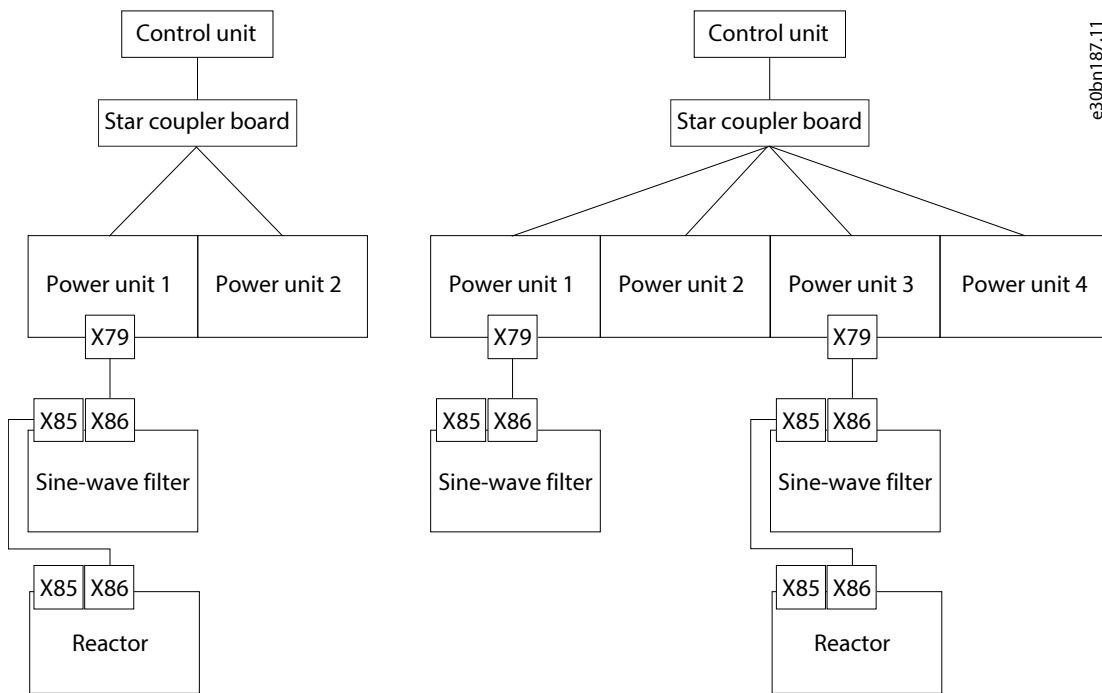

e30bn187.11

Figure 133: AuxBus Topology for OF7SO2

7.14.2 AuxBus Cable Requirements

It is recommended to use the AuxBus cables that are provided by Danfoss. AuxBus is delivered with 2 m (6.6 ft) of cable. If other cables are used, see [Table 23](#).

NOTICE

RISK OF ELECTRICAL INTERFERENCE

AuxBus consists of point-to-point connection, but the signals are connected in series. Cables that are longer than 10 m (33 ft) can create interference and communication problems.

- Do not exceed 10 m (33 ft) of total AuxBus cabling.
- Keep AuxBus cables as short as possible and separate them from high-power cables.

Table 23: Cable Requirements for Other than Danfoss-provided Cables

Item	Value
Cable type	6-wire, shielded and twisted pair (STP)
Impedance	120 Ω
Maximum length	10 m (33 ft)

Cable (example): LAPP KABEL, UNITRONIC® BUS LD FB P, 2170215.

Cable (example, UL): LAPP KABEL, UNITRONIC® BUS LD FB P A, 2170815.

Connector: Phoenix Contact, MC 1,5 /5-ST-3,5 BK, 1769919 (LCL Filter: 2721-105/026-000).

Cabling recommendation for drives with a loose option AuxBus.

Cabling recommendation for drives with integration unit filters.

7.14.3 AuxBus Grounding Principles

To ensure robust communication, good grounding strategy is needed. Below is a recommended grounding strategy illustrated using integration units. Same strategy can be applied for loose option filters.

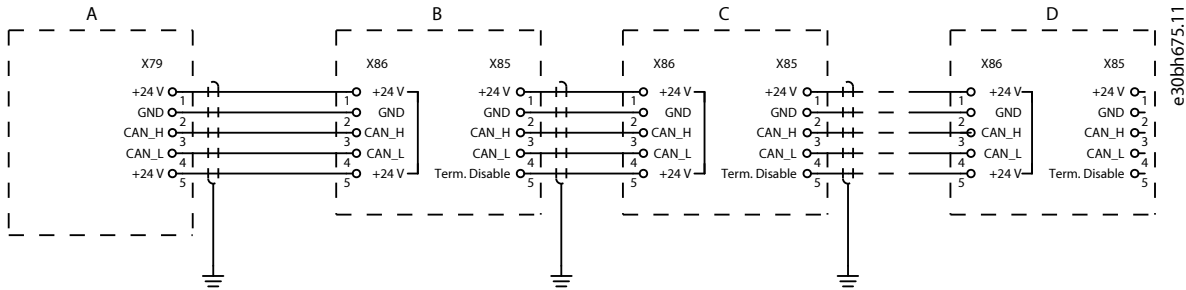

Figure 134: AuxBus Circuit Diagram

- | | | | |
|---|--|---|----------------|
| A | The AuxBus interface in the power unit | B | AuxBus board 1 |
| C | AuxBus board 2 | D | AuxBus board 3 |

7.15 The Pre-charging Unit

The pre-charging unit is used for pre-charging the system modules that are connected to the same DC bus. There are 3 electrical sizes, and an IEC and an UL variant of these. The pre-charging unit is available as an accessory.



NOTE: If the used DC voltage is higher than 1200 V DC, the pre-charging units cannot be used with products with the voltage class G7 (380–690 V AC (500–1500 V DC)).

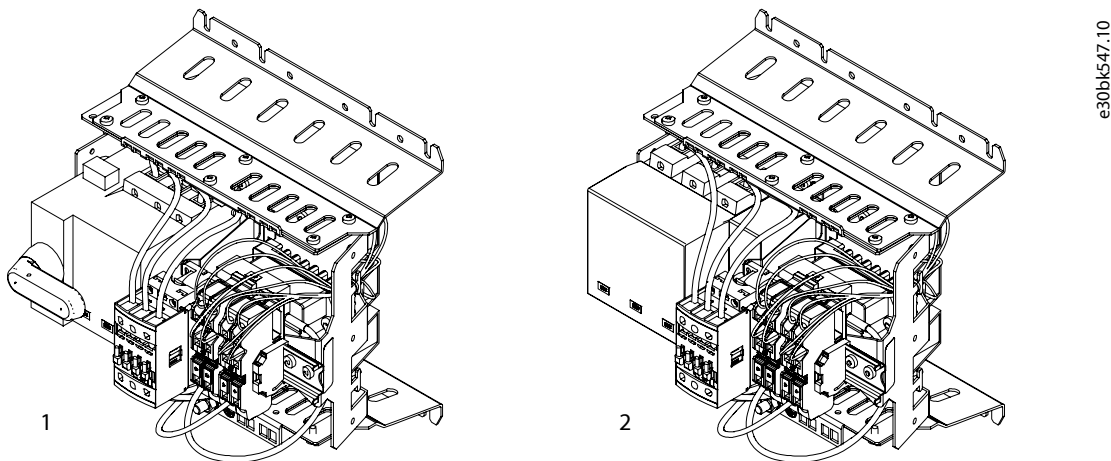

Figure 135: Pre-charging Units

- | | | | |
|---|------------------------|---|-----------------------|
| 1 | Pre-charging unit, IEC | 2 | Pre-charging unit, UL |
|---|------------------------|---|-----------------------|

Table 24: Selection of the Correct Pre-charging Unit

System modules	Pre-charging unit
IM10L + IM10L/IR10L + IR10L	Pre-charging unit 10 (IEC or UL)
IM12L + IM12L/IR12L + IR12L	
2 x IM12L + 2 x IM12L/2 x IR12L + 2 x IR12L	
3 x IM12L + 3 x IM12L/3 x IR12L + 3 x IR12L	
4 x IM12L + 4 x IM12L/4 x IR12L + 4 x IR12L	
5 x IM12L + 5 x IM12L/5 x IR12L + 5 x IR12L	Pre-charging unit 20 (IEC or UL)
6 x IM12L + 6 x IM12L/6 x IR12L + 6 x IR12L	
7 x IM12L + 7 x IM12L/7 x IR12L + 7 x IR12L	
8 x IM12L + 8 x IM12L/8 x IR12L + 8 x IR12L	

Table 25: Maximum Capacitance of the Pre-charging Unit

Pre-charging unit	Network [V AC]	Capacitance [μ F]
Pre-charging unit 10 (IEC or UL)	400/500	66500
	690	29500
Pre-charging unit 20 (IEC or UL)	400/500	184000
	690	76500
Pre-charging unit 30 (IEC or UL)	400/500	275000
	690	114500

There are thermal restrictions in a repeated use of the pre-charging unit. See the allowed pre-charging cycle in a 60 °C (140 °F) ambient temperature in [Table 26](#).

Table 26: The Thermally Allowed Pre-charging Cycle

Step	Task	Duration
1.	Charging	10 s
2.	Discharging	50 s
3.	Charging	10 s
4.	Discharging	50 s
5.	Wait for the pre-charging unit to cool down.	10 min
6.	Repeat	–

7.16 Derating

7.16.1 Derating of Switching Frequency INU, Voltage Class A5

The inverter can be used without derating up to 5 kHz while using Modulator Type 6. For switching frequencies above 5 kHz, or if Modulator Type 1 is used, current must be derated according to [Figure 136](#).

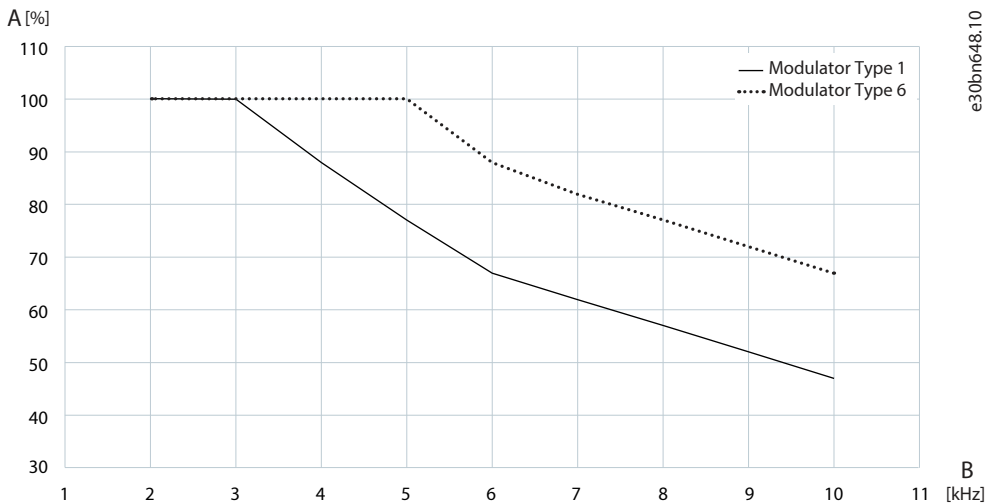

Figure 136: Derating of Switching Frequency INU, Voltage Class A5

7.16.2 Derating of Switching Frequency INU, Voltage Class B5 and 07

The inverter can be used without derating up to 3 kHz while using Modulator Type 6. For switching frequencies above 3 kHz, or if Modulator Type 1 is used, current must be derated according to [Figure 137](#).

The derating is not relevant for the products with the sine-wave filter option +AES1.

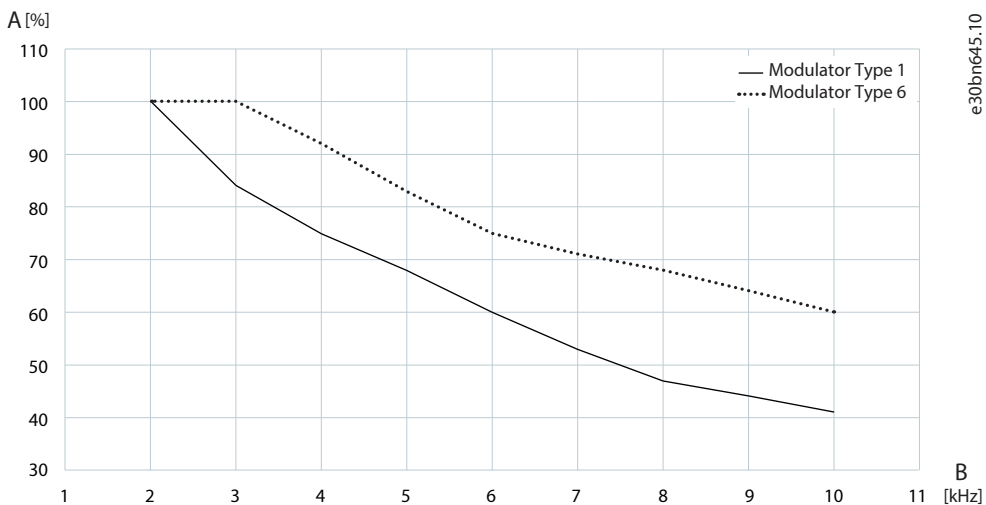

Figure 137: Derating of Switching Frequency INU, Voltage Class B5 and 07

7.16.3 Derating of Coolant Temperature, Voltage Class A5

The liquid-cooled system modules can be used without derating up to 45 °C (113 °F) or 40 °C (104 °F), depending on the current rating. For higher coolant temperatures, current must be derated 1.5%/1 °C (1.5%/1.8 °F) as shown in the following diagram.

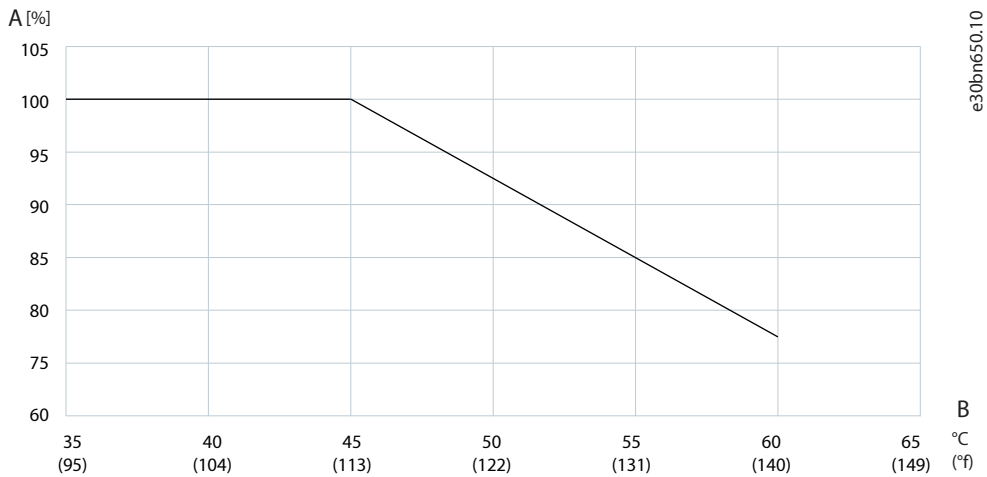

Figure 138: Coolant Temperature Derating, Voltage Class A5

7.16.4 Derating of Coolant Temperature, Voltage Class B5 and 07

The liquid-cooled system modules can be used without derating up to 38 °C (100 °F) or 45 °C (113 °F), depending on the current rating. For higher coolant temperatures, current must be derated 1%/1 °C (1%/1.8 °F) as shown in the following diagram.

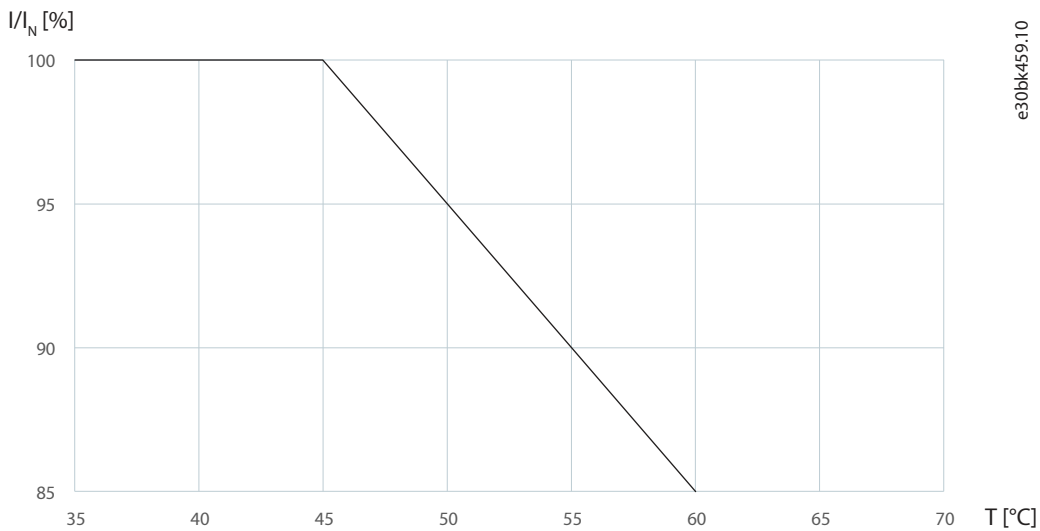

Figure 139: Coolant Temperature Derating, Voltage Class B5 and 07

7.16.5 Derating of DC-bus Voltage, Voltage Class A5

The drive can be used without derating up to 743 V DC. For DC-bus voltages higher than 743 V DC, current must be derated according to [Figure 140](#).

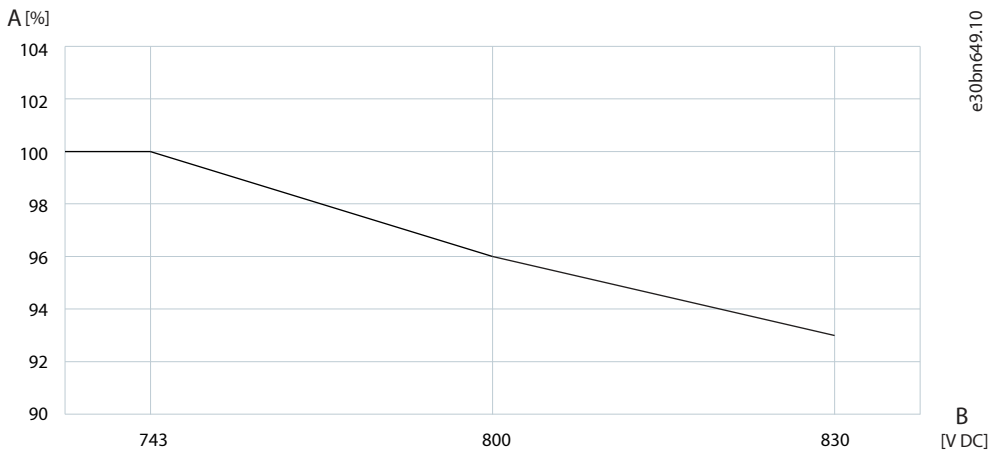

Figure 140: DC-bus Voltage Derating, Voltage Class A5

7.16.6 Derating of DC-bus Voltage

With the voltage rating 07 (extended voltage range 400–690 V AC), the drive can be used without derating up to 1025 V DC. For DC-bus voltages higher than 1025 V DC, current must be derated according to the diagram. The voltage rating G7 (500–1500 V DC) does not require derating up to maximum DC-voltage of 1500 V DC.

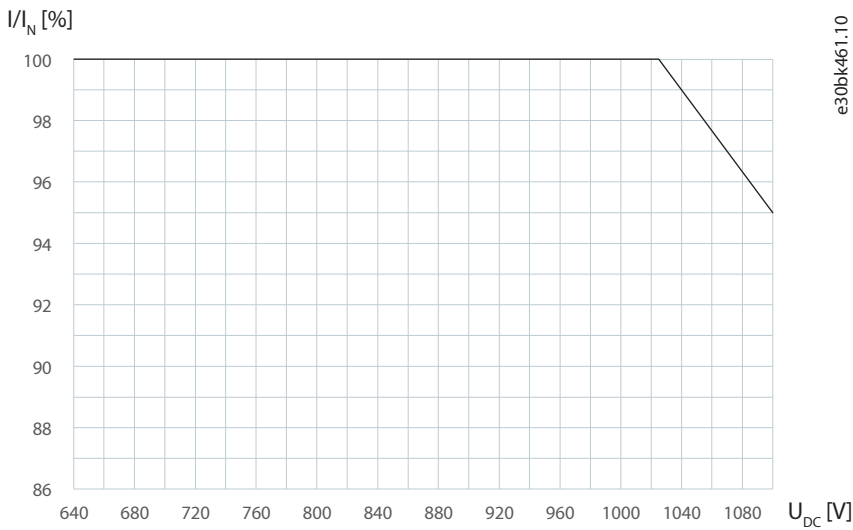

Figure 141: DC-bus Voltage Derating

7.16.7 Derating of Output Frequency, Voltage Class A5, B5, and 07

With an output frequency below 5 Hz, the output current is derated by 4.5% per 1 Hz. For example, with a 2 Hz output frequency the derating factor is 0.865.

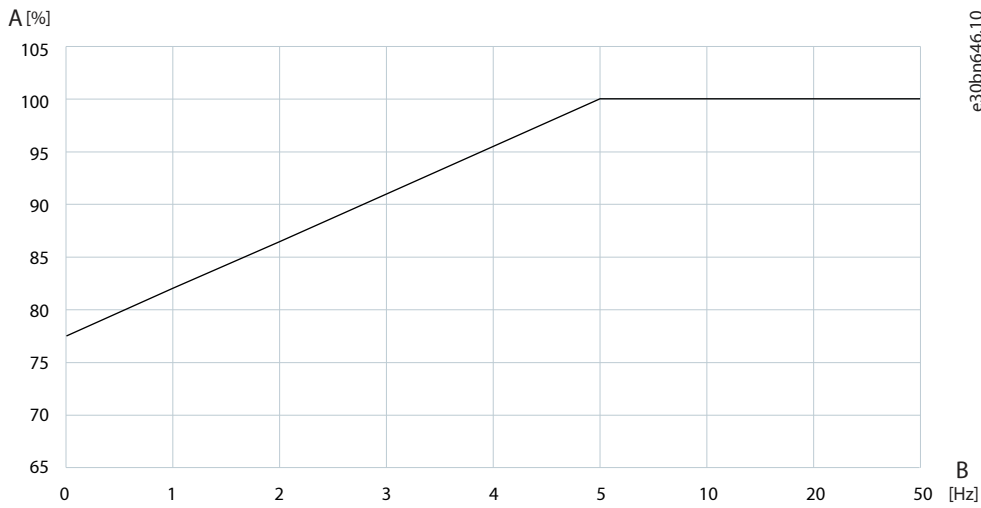

Figure 142: Derating of Output Frequency, Voltage Class A5, B5, and 07

7.16.8 Derating of Switching Frequency DC/DC, Voltage Class B5 and 07

If a switching frequency higher than 6 kHz is used, the DC/DC converter must be derated according to [Figure 143](#).

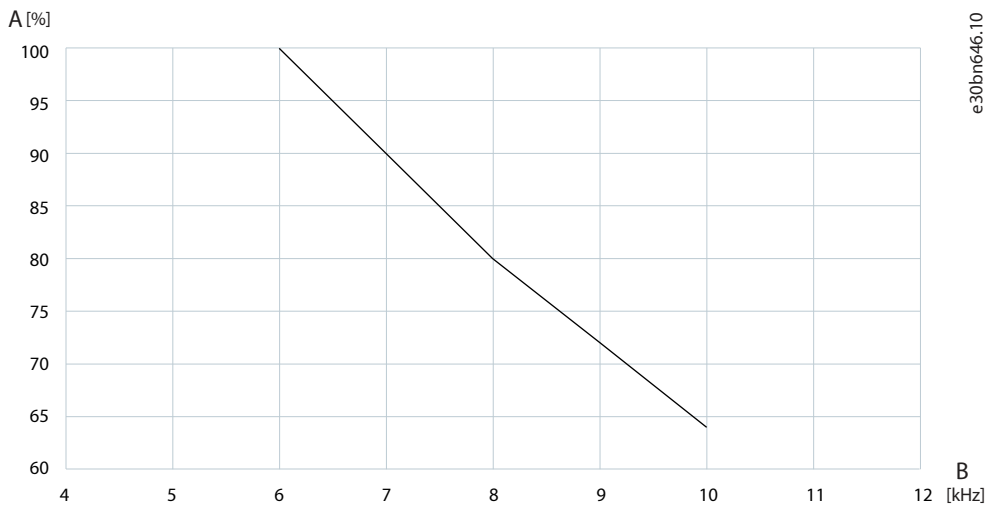

Figure 143: Derating of Switching Frequency DC/DC, Voltage Class B5 and 07

7.16.9 Derating of Voltage Imbalance, AFE/GC

AFE and grid converter units can be used without derating up to 3%. For voltage imbalances higher than 3%, current must be derated according to the diagram.

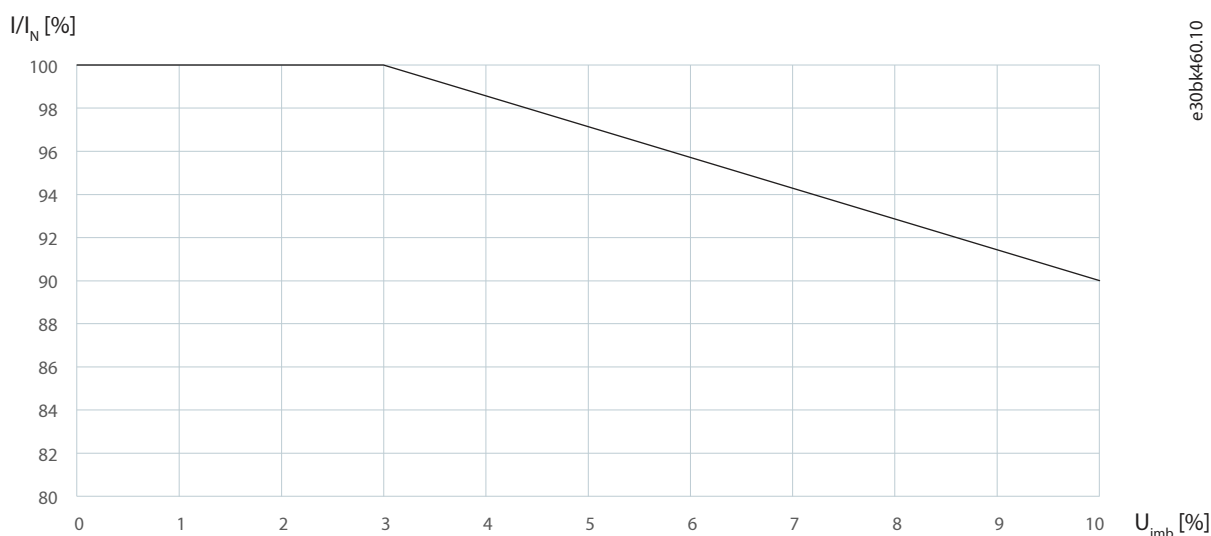

Figure 144: Voltage Imbalance Derating

7.17 Modulator Types

The following are the available modulator types for AFE, GC, and INU modules. For more detailed descriptions and instructions on modulator type selection, see the iC7 series application guides.

Modulator types for AFE and GC

Modulator type 4 – CMRPWM (default for AFE)

- This modulator can be used in the AFE to minimize motor line-ground voltage spikes. The modulator cannot be used when independent paralleling is used (when *Paralleling sync. Mode* is enabled).

Modulator type 5 – GridConverter (default for A5 and O7 voltage class GC)

- The modulator optimizes the trade-off between losses and harmonics during normal operation, while enabling short-term current injection STCI. Independent paralleling is feasible with this modulator type (*Paralleling sync. Mode* is enabled).

Modulator type 1 – SVPWM, Standard Space Vector Pulse Width Modulation (default for G7 voltage class (1500 V DC))

- Derating required for O7 and A5 voltage class.

Modulator types for INU

Modulator type 1 – SVPWM

- Standard Space Vector Pulse Width Modulation. Drive derating is required.

Modulator type 6 – Hybrid2 (default)

- Optimizes the trade-off between losses and harmonics during normal operation. The best selection in most applications.

Modulator for BCU and DC/DC

Modulator types for BCU.

- 3-phase six-step modulation to share the load equally between phases.

Modulator types for DC/DC.

- 120-degree interleaved modulation to reduce source current ripple.



NOTE: BCU and DC/DC use product-specific modulation that cannot be modified.

8 Control Unit

8.1 Modular Control Unit

The maximum input power of the internal 24 V DC power supply is 60 W.

NOTICE

EXTERNAL 24 V DC POWER SUPPLY NEEDED

The power units do not provide a 24 V DC power supply for the control unit. Lack of a 24 V DC power supply prevents the operation of the product.

- Provide an external 24 V DC +15%/-10% power supply for the control unit.

NOTICE

CABLE INSULATION

- Insulation between 2 circuits must be designed according to the circuit that has the highest voltage.

NOTICE

SEPARATE 24 V WIRES FROM 115/240 V CABLES

The 24 V wires must be separated from the 115 V/240 V cables. If they are not separated, all wirings must be made with shielded 115 V/240 V cables.

NOTICE

SIGNAL CABLES

- It is recommended to use shielded/twisted pair signal cables.

NOTICE

USE FERRULES WITH STRANDED CABLES

- It is recommended to use ferrules with stranded supply, I/O, and signal cables.

Table 27: Maximum Power Consumption of the Control Unit Components

Component	Power consumption [W]
Control unit, including control panel	6
Star coupler board	4
I/O and Relay Option, 250 mA at 24 V _{out}	8
Any other option board, 1 pcs	4

The system modules are controlled with the modular control unit. The control and I/O board circuits are DVC As circuits. The control unit and the system modules are connected via fiber optics. When 2 or more parallel system modules are used, a star coupler board is needed. The modular control unit provides an interface towards the upper control system. The control unit includes 2 Ethernet ports for a fieldbus connection. Daisy chaining the fieldbus is supported for typical protocols, such as Modbus TCP and PROFINET RT. Additional functional extensions can be added to incorporate analog and digital inputs and outputs as well as other functionality such as temperature measurement or voltage measurement. A control panel is available for local control.

The modular control unit can be mounted nearby or remotely from the power unit. The control unit consists of various boards installed on a mounting plate. The boards are connected to each other with option connectors. Several boards and mounting plates can be installed in parallel.

There are 3 different mechanical board types in the modular control unit:

- Control board
- Star coupler board
- Functional extensions, for example:
 - I/O and Relay Option
 - Encoder/Resolver Option
 - Temperature Measurement Option
 - Voltage Measurement Option

See more information on the option boards in the *iC7 Series Functional Extension Options Installation Guide*, the *iC7 Series Functional Extension Options Operating Guide*, and the *iC7 Series Voltage Measurement Option OC7V0 Operating Guide*.

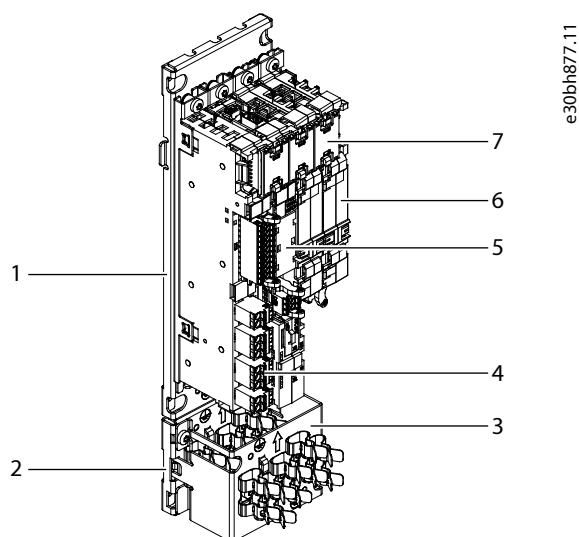
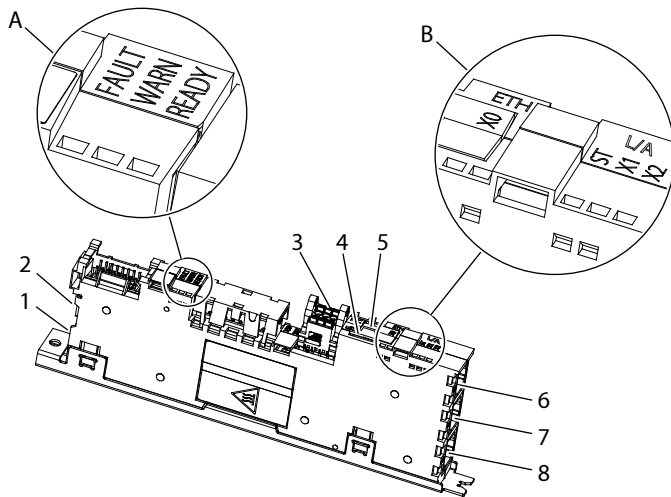

Figure 145: Example of the Modular Control Unit

1	Mounting plate	2	Base grounding plate
3	Grounding plate extension	4	I/O and Relay Option
5	Control board	6	Option board
7	Option connector		

8.2 Control Board



e30bi630.12

Figure 146: The Control Board

A	Status indicators (FAULT, WARN, READY)	B	Fieldbus indicators (ST, X1, X2) and Ethernet port indicators (X0)
1	Control panel connector (X9)	2	Fiber optic link to power unit (X80)
3	24 V DC supply (X62)	4	microSD card
5	RTC battery holder	6	Ethernet port (X0)
7	Ethernet port (X1)	8	Ethernet port (X2)

8.3 Definitions of the Indicator Lights on the Control Board

Table 28: Definitions of the Indicator Lights on the Control Board

Indicator name	Function (color)	Description
Fault	On (red)	Fault active
Warn	On (yellow)	Warning active
Ready	On (white)	Ready for operation
	Blinking 1 Hz (white)	Power on, not ready
Fault+Warn+Ready	Blinking (red + yellow + white)	Winking from an external application. Can be used for identifying where the external application is wirelessly connected to.
X0 link activity	Off	No link
	On (green)	Link OK, no data
	Blinking (green)	Link OK, data communication
X0 link speed	Off	No link or 10 Mbps link
	On (orange)	100 Mbps link

For the description of the fieldbus indicators (ST, X1, X2), see the relevant application guide.

8.4 Control Board Connections

Table 29: Control Board Connections

Terminal	Function	Connector type
X1	Ethernet port (used for fieldbus)	RJ45
X2	Ethernet port (used for fieldbus)	RJ45
X0	Ethernet port (used for the PC tool)	RJ45
Micro SD	microSD card	Micro SD
X62	24 V DC supply	2 x 3 spring force connector 0.2–1.5 mm ²
X33 for inverter module	STO terminal	1 x 10 spring force connector 0.2–1.5 mm ²
Option bus	Option bus (internal connection)	Custom
X80	Fiber optic link to power unit or star coupler board	LC-duplex
X9	Control panel terminal	iX Industrial
RTC battery	RTC battery	Battery type: <ul style="list-style-type: none"> • Panasonic BR1632A (3 V +125 C°) • Jauch Quartz CR1632 (246335) (3 V, +85 C°) • Renata Batteries CR1632 (3 V, +85 C°)

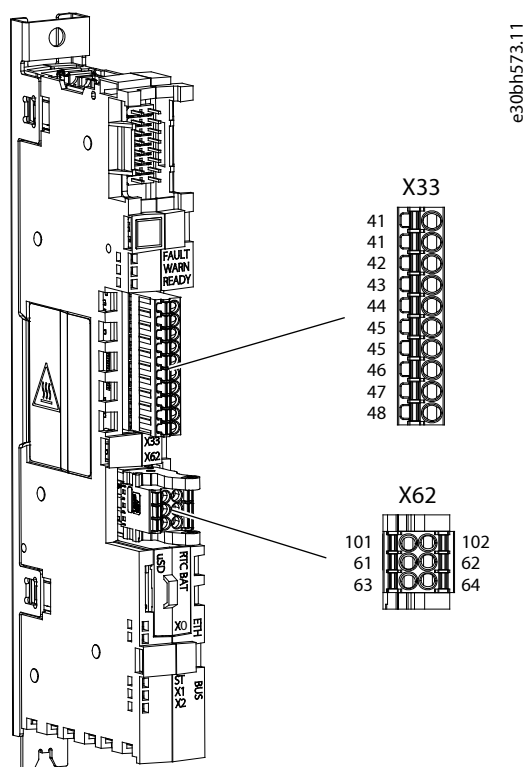
Figure 147: Control Board Terminal Block and Terminal Numbering
Table 30: STO Terminal Signals (X33) for the Inverter Module

Terminal	Function	Description
41A ⁽¹⁾	24 V	+ 24 V DC Output
41B ⁽¹⁾	24 V	+ 24 V DC Output

Table 30: STO Terminal Signals (X33) for the Inverter Module - (continued)

Terminal	Function	Description
42	S.INA+	+ Safe Input Channel A
43	S.INB+	+ Safe Input Channel B
44	S.FB+	+ STO Feedback
45A ⁽¹⁾	GND	0 V/GND
45B ⁽¹⁾	GND	0 V/GND
46	S.INA-	- Safe Input Channel A
47	S.INB-	- Safe Input Channel B
48	S.FB-	- STO Feedback

1) Terminals 41A, 41B, 45A, and 45B have double pins to make connections easier.

Table 31: 24 V DC Supply Signals (X62)

Terminal	Function	Description
101	+24 V input	Internal +24 V DC, 60 W control supply
102	GND	Power supply ground
61	+24 V external input	External +24 V DC control supply, maximum 10 A. Must be fuse-protected. Possible to daisy chain for multiple controllers.
62	GND	Power supply ground
63	+24 V output	+24 V DC output for daisy chain, only available when the +24 V DC external input control supply is used.
64	GND	Power supply ground

For the circuit diagrams of the control unit, see [10.3.16 Wiring Diagrams of the +24 V Supply for the Control Unit](#).

8.5 Star Coupler Board

System modules for high current ratings consist of multiple power units that are connected via a star coupler board to 1 control unit.

With the star coupler board, it is possible to connect up to 16 power units in parallel. The fiber connection is always needed between the control board and star coupler board.

An external 24 V power supply is required for the star coupler board. Connect the supply to the top of the star coupler board.

The star coupler board can be installed next to the control unit. The star coupler board can also be installed near the power units to make the cabling from the star coupler board to the power units easier. See [Figure 152](#) and [Figure 153](#).

Connect the power units to the star coupler board in numerical order, starting from terminals X301, X302, and so on.

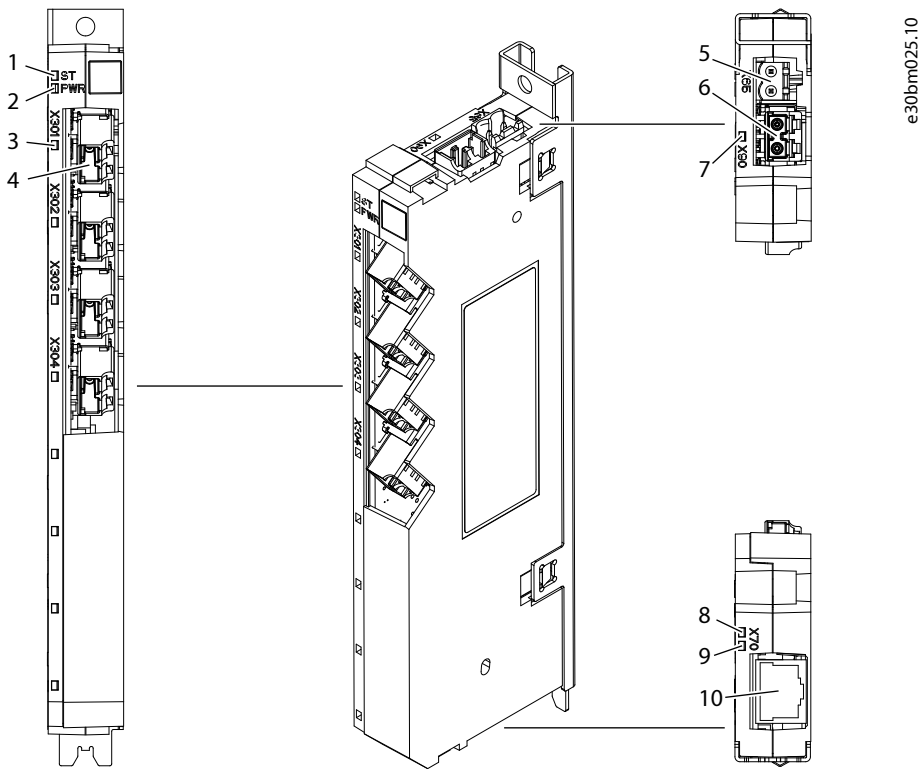

e30bm025.10

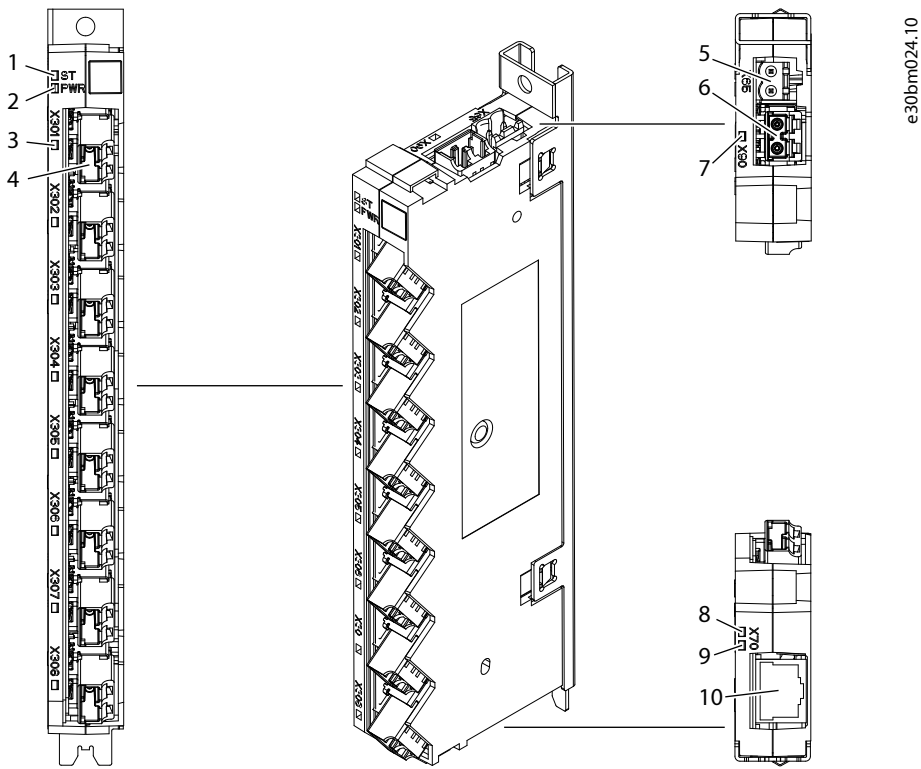

e30bm024.10

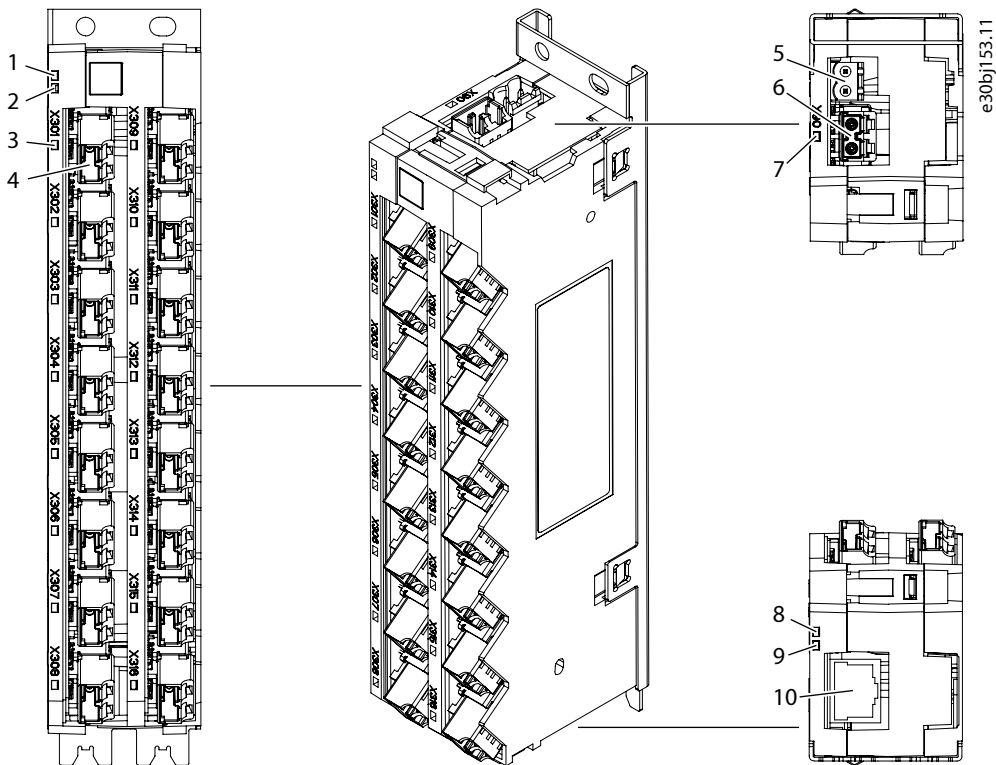

Figure 150: Terminal and Indicator Light Locations on the 16-port Star Coupler Board

1	Board configuration status indicator	2	+24 V power status indicator
3	Power unit connection status indicators	4	Fiber connection to the power unit (X301–X316)
5	+24 V power supply (X65)	6	Fiber connection to the control board (X90)
7	Control link status indicator	8	Ethernet speed indicator
9	Ethernet link activity indicator	10	Ethernet port (X7), only for service use

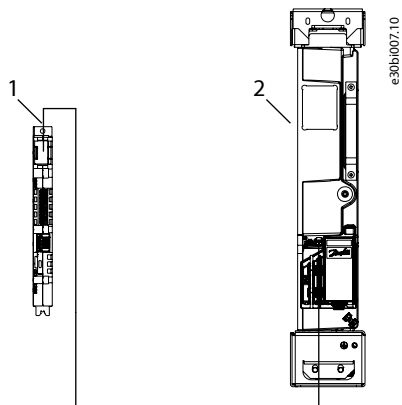
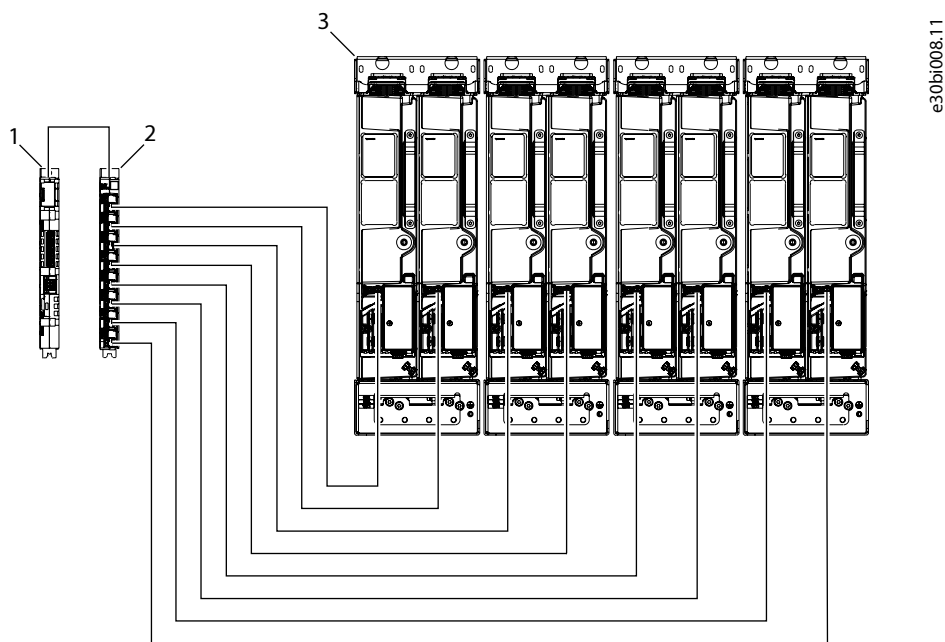

Figure 151: Control Connection

1	Control board	2	Power unit
---	---------------	---	------------



e30bi008.11

Figure 152: Example Control Connection with a Star Coupler Board: 8 Power Units in Parallel

- | | | | |
|---|------------------------|---|--------------------|
| 1 | Control board | 2 | Star coupler board |
| 3 | Maximum 16 power units | | |

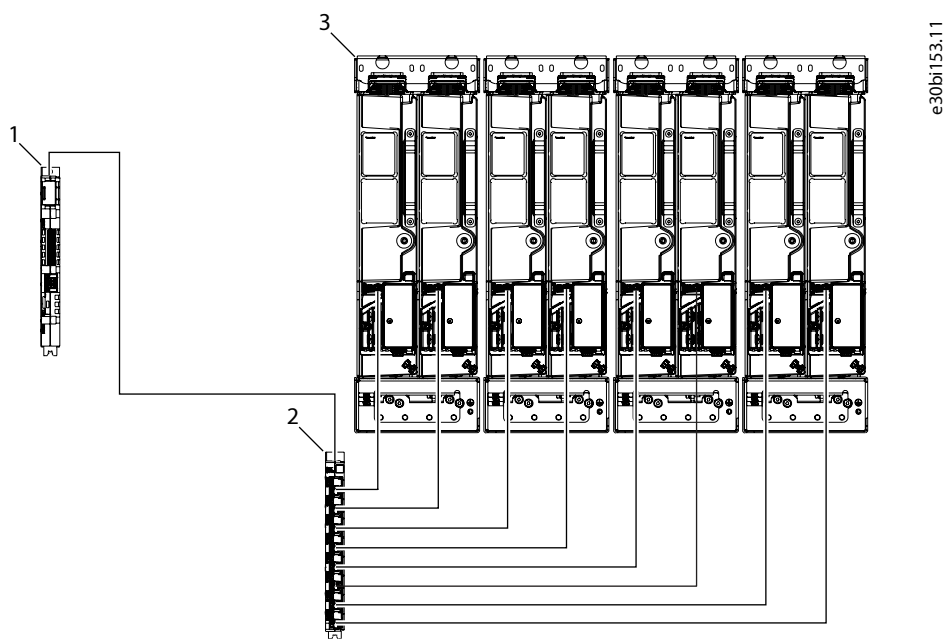

e30bi153.11

Figure 153: Example Control Connection with a Star Coupler Board: 8 Power Units in Parallel, Star Coupler Board near the Power Units

- | | | | |
|---|------------------------|---|--------------------|
| 1 | Control board | 2 | Star coupler board |
| 3 | Maximum 16 power units | | |

8.6 Definitions of the Indicator Lights on the Star Coupler Board

Table 32: Definitions of the Indicator Lights on the Star Coupler Board

Indicator name	Function (color)	Description
Configuration status	Off	During booting, until the software configuration is executed.
	Blinking 10 Hz (green)	Software updating.
	On (green)	Board configuration succeeded and all port communication works as intended.
	On (red)	Board configuration failed or any port communication failed on startup or during run.
24 V power status	On (white)	Star coupler board is powered. ⁽¹⁾
Power unit link status (X301–X316)	Off	No link established.
	On (green)	Link established.
Control link status	Off	No link established.
	On (green)	Link established.
Ethernet speed	Off	No link or 10 Mbps link
	On (orange)	100 Mbps link
Ethernet link activity	Off	No link
	On (green)	Link OK, no data
	Blinking (green)	Link OK, data communication

1) If there is no software on the star coupler board or the software cannot be executed, the indicator light does not turn on.

8.7 Star Coupler Board Connections

Table 33: Star Coupler Board Connections

Terminal	Function	Connector type
X7	Ethernet port	RJ45
X65	24 V DC supply	2 x spring force connector 2.5 mm ²
X90	Fiber optic link to control board	LC-duplex
X301–X316	Fiber optic link to power unit	LC-duplex

Table 34: 24 V DC Supply Signals (X65)

Terminal	Function	Description
61	+24 V external input	External +24 V DC star coupler supply, maximum 10 A. Must be fuse-protected.
62	GND	Power supply ground

8.8 I/O and Relay Option (OC7C1) Connections

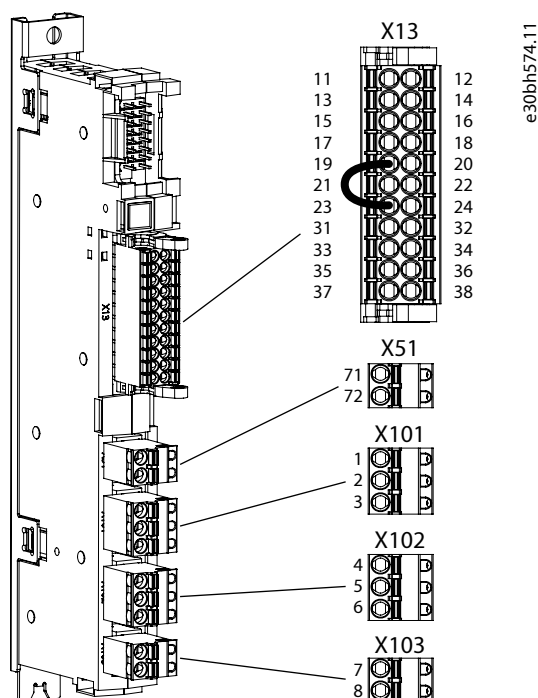

Figure 154: I/O and Relay Option Terminal Block and Terminal Numbering

Table 35: I/O and Relay Option (OC7C1) Signals

Terminal	Function	Connector type
X13	I/O terminal	2 x 11 spring-force connector 0.2–1.5 mm ²
X51	Thermistor input	1 x 2 spring-force connector 0.25–2.5 mm ²
X101	Relay 1	1 x 3 spring-force connector 0.25–2.5 mm ²
X102	Relay 2	1 x 3 spring-force connector 0.25–2.5 mm ²
X103	Relay 3	1 x 2 spring-force connector 0.25–2.5 mm ²

Table 36: I/O Terminal Signals (X13)

Terminal	Function	Description
11	+24 V _{out}	Control voltage output.
12	+24 V _{out}	24 V DC (-15...+20%) Maximum current 200 mA Short-circuit protected
13	DI 1	Configurable digital input, galvanically isolated. 24 V DC, 0 < 5 V, 1 > 15 V. Input load 7.5 mA constant current + 10 kΩ resistive load, maximum pulse frequency 100 kHz.
14	DI 2	
15	DI 3	
16	DI 4	
17	DI 5	
18	DI 6	

Table 36: I/O Terminal Signals (X13) - (continued)

Terminal	Function	Description
19	DGND	Digital input ground, not isolated by default.
20	DGND	When using the internal +24 V _{out} supply, connect the external jump wire between DGND and GND. When using the external +24 V DC supply, remove the external jump wire between DGND and GND.
21	DO 1	Configurable digital output. ⁽¹⁾
22	DO 2	Push-pull 24 V/50 mA Open collector (NPN/PNP) 48 V/50 mA Short-circuit protected
23	GND	I/O ground.
24	GND	Ground for digital outputs, +10 V Ref, +24 V _{out} , analog inputs, and analog outputs.
31	AO 1	Configurable analog output. Voltage mode: <ul style="list-style-type: none"> • 0...10 V • $R_L \geq 1 \text{ k}\Omega$ • Accuracy $\leq \pm 0.5\%$ of full scale • Short-circuit protected Current mode: <ul style="list-style-type: none"> • 0...20 mA • $R_L \leq 600 \Omega$ • Accuracy $\leq \pm 0.5\%$ of full scale • Short-circuit protected
32	+10 V ref.	10 V (0...+3%), maximum current 10 mA
33	AI 1	Configurable analog input.
34	AI 2	Voltage mode: <ul style="list-style-type: none"> • $0 \pm 10 \text{ V}$ • Single-ended • $R_i \sim 10 \text{ k}\Omega$ • Accuracy $\pm 0.5\%$ of full scale Current mode: <ul style="list-style-type: none"> • $0 \pm 20 \text{ mA}$ • Differential • $R_i \sim 200 \Omega$ • Accuracy $\pm 0.5\%$ of full scale
35	GND	I/O ground.
36	GND	Ground for digital outputs, +10 V Ref, +24 V _{out} , analog inputs, and analog outputs.
37	GND	
38	GND	

1) Digital outputs are not recommended for main circuit breaker control, use relay outputs instead.

Table 37: Thermistor Input Signals (X51)

Terminal	Function	Description
71	TI+	Thermistor input, galvanically isolated. $R_{trip} = 4\text{ k}\Omega$
72	TI-	

Table 38: Relay 1 Signals (X101)

Terminal	Function	Description
1	COM	Configurable relay output. Switching capacity: <ul style="list-style-type: none"> • 24 V DC/8 A • 250 V AC/8 A • 125 V DC/0.4 A Minimum switching load: 5 V/10 mA
2	NO	
3	NC	

Table 39: Relay 2 Signals (X102)

Terminal	Function	Description
4	COM	Configurable relay output. Switching capacity: <ul style="list-style-type: none"> • 24 V DC/8 A • 250 V AC/8 A • 125 V DC/0.4 A Minimum switching load: 5 V/10 mA
5	NO	
6	NC	

Table 40: Relay 3 Signals (X103)

Terminal	Function	Description
7	COM	Configurable relay output. Switching capacity: <ul style="list-style-type: none"> • 24 V DC/8 A • 250 V AC/8 A • 125 V DC/0.4 A Minimum switching load: 5 V/10 mA
8	NO	

8.9 I/O and Relay Option Interface

8.9.1 Analog Inputs

The I/O and Relay Option has 2 analog inputs that can be configured with the software to voltage input or current input. The [Table 41](#) shows the specification for the analog inputs.

The analog inputs are protected in overvoltage conditions.

Table 41: Analog Input Types, Values, and Tolerances

Parameter	Value
Measuring range: voltage mode	-10...+10 V
Measuring range: current mode	-20...+20 mA

Table 41: Analog Input Types, Values, and Tolerances - (continued)

Parameter	Value
Input impedance	Voltage mode $\approx 10\text{ k}\Omega$
	Current mode $\approx 200\ \Omega$
Accuracy	0.5% of full scale
Reaction time	0...90% step: $< 1\text{ ms}$
Number of inputs	2
Overvoltage limit	+15/-15 V
Overcurrent limit	+32/-32 mA
Electrical fast transient (EFT)	2 kV

8.9.2 Analog Outputs

The I/O and Relay Option has 1 analog output that can be configured with the software to voltage output or current output. [Table 42](#) shows the specification for the analog output.

The analog output is protected in overvoltage conditions.

Table 42: Analog Output Types and Values

Parameter	Value
Output voltage range	0...10 V
Output current range	0...20 mA
Accuracy	0.5% of full scale
Reaction time	0...90% step: $< 1\text{ ms}$
Electrical fast transient (EFT)	2 kV

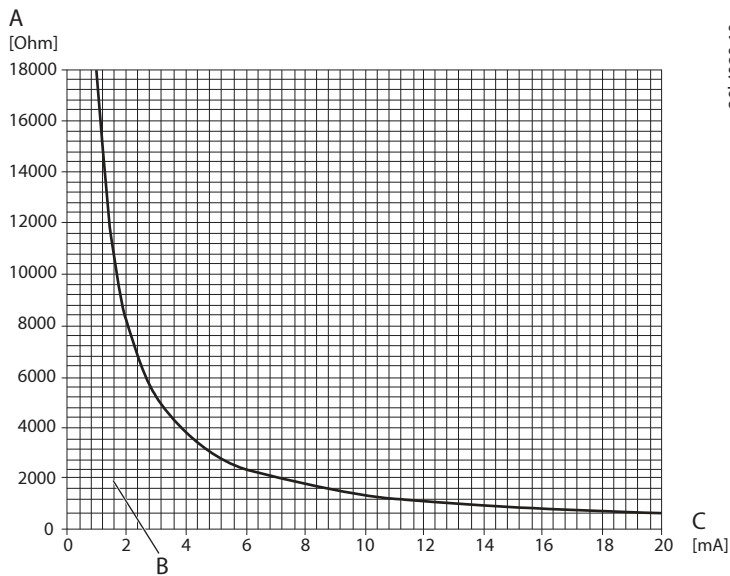

Figure 155: Allowed Load Resistance of Analog Output in Current Mode

A	Load resistance	B	Allowed load resistance
C	Output current		

8.9.3 Digital Inputs

The I/O and Relay Option has 6 digital inputs. By default, the digital inputs are not isolated, because there is an external wire between the connector pins 19 (D_{GND}) and 23 (GND). The digital inputs can be functionally isolated from the PCB ground of the I/O and Relay Option by removing the wire. The digital inputs are polarity free.

Digital inputs are overvoltage protected.

Table 43: Digital Inputs Logic Levels and Other Requirements

Parameter	Value
Recommended operation voltage	0...24 V +20%/-10%
Overvoltage limit	33 V
Logic level	0 = $V_{TL} \leq 5$ V 1 = $V_{TH} \geq 15$ V
Input load	7.5 mA constant current and 10 k Ω resistive load
Reaction time	< 5 μ s
Maximum frequency	100 kHz
Electrical fast transient (EFT)	2 kV

8.9.4 Digital Outputs

The I/O and Relay Option has 2 digital outputs. The digital outputs are the push-pull type. The digital outputs can also be used as the open collector type.

The digital outputs are short-circuit protected.

Table 44: Digital Output Voltage and Current

Parameter	Value
Output voltage	0 = max 2 V 1 = min 20 V
Rated current	\pm 50 mA
Overcurrent limit	\pm 80 mA
Maximum voltage when used as open collector output	48 V
Maximum frequency	100 kHz
Electrical fast transient (EFT)	2 kV

1) Control unit power supply 24 V +20%/-10% and I_{load} max 50 mA

8.9.5 Relay Outputs

The I/O and Relay Option has 3 relay outputs. Relay 1 and Relay 2 have NO and NC contacts [1 form C (CO)]. Relay 3 has only an NO contact [1 form A (NO)]. The relay output interface is reinforced for system voltages \leq 300 V. The lifetime for relays is 100.000 cycles.

Table 45: Relay Output Values

Parameter	Value
Rated voltage	250 V AC
Maximum switching voltage	400 V AC
Rated current	8 A
Breaking capacity maximum	2000 VA

Table 45: Relay Output Values - (continued)

Parameter	Value
Operate time maximum	9 ms
Release time maximum	5 ms
DC breaking capacity	See Figure 156 .

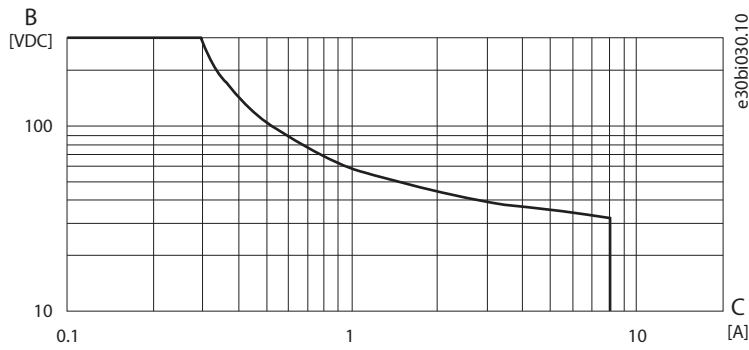

Figure 156: Maximum DC Load Breaking Capacity

B DC voltage C DC current

8.9.6 Analog Reference Voltage Output

The I/O and Relay Option contains 1 analog reference voltage output.

Table 46: Analog Reference Voltage Output Values

Parameter	Value
Nominal voltage	10 V
Accuracy	-3...+3% of nominal voltage
Maximum output current	10 mA
Short-circuit current	13 mA
Electrical fast transient (EFT)	2 kV

8.9.7 24 V DC Voltage Output

The I/O and Relay Option contains 1 voltage output of 24 V DC.

Table 47: 24 V DC Voltage Output

Parameter	Value
Nominal voltage	24 V
Accuracy	-15...+20%
Maximum output current	200 mA
Short-circuit current	250 mA
Electrical fast transient (EFT)	2 kV

8.9.8 Thermistor Input

The I/O and Relay Option contains 1 thermistor input. Thermistor input has basic isolation for system voltages ≤ 600 V and reinforced isolation for system voltages ≤ 300 V (OVC III 3000 m). For system voltage of 600 V, supplementary insulation is necessary at the motor end.

Table 48: Thermistor Input

Parameter	Value
Electrical fast transient (EFT)	2 kV
Sensor	R_{trip} 4.0 k Ω (PTC)

8.10 Assembling the Control Unit Mounting Plates

Use these instructions to assemble the mounting plate of the modular control unit. All the parts can be found in the accessories bag.

1. Assemble the mounting plate as shown in the illustration.
 - a. Attach the base grounding plate into the mounting plate.
 - b. Align the cable clamps in the holes in a wave-like form and attach with screws.
 - c. Attach the grounding plate extension onto the base grounding plate with 2 screws.
 - d. Attach the cable clamps with screws.

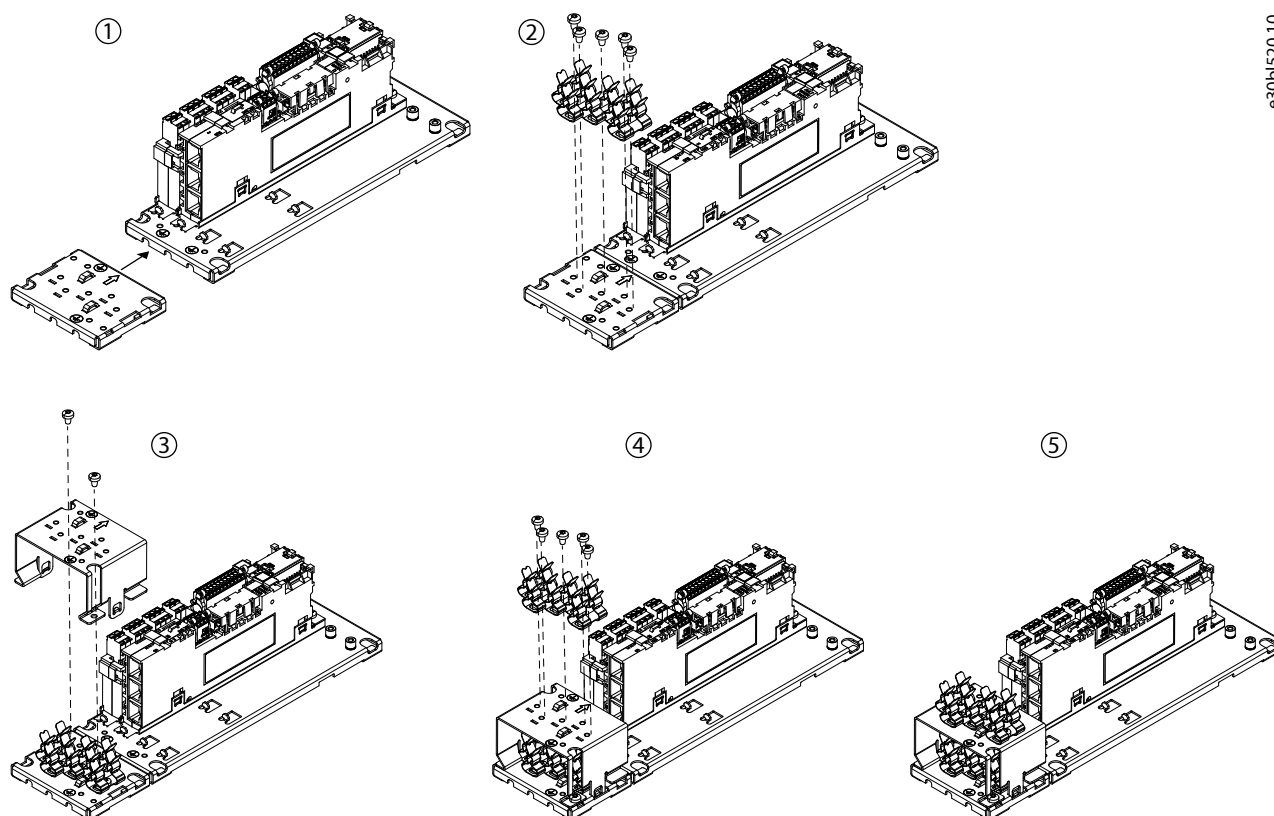

Figure 157: Assembling the Mounting Plate

8.11 Attaching the Control Unit Mounting Plates

Use these instructions to attach 2 or several mounting plates to each other, and to install mounting plates to the cabinet. All the parts can be found in the accessories bag.

1. Install the mounting plates to each other by fitting the sides together.

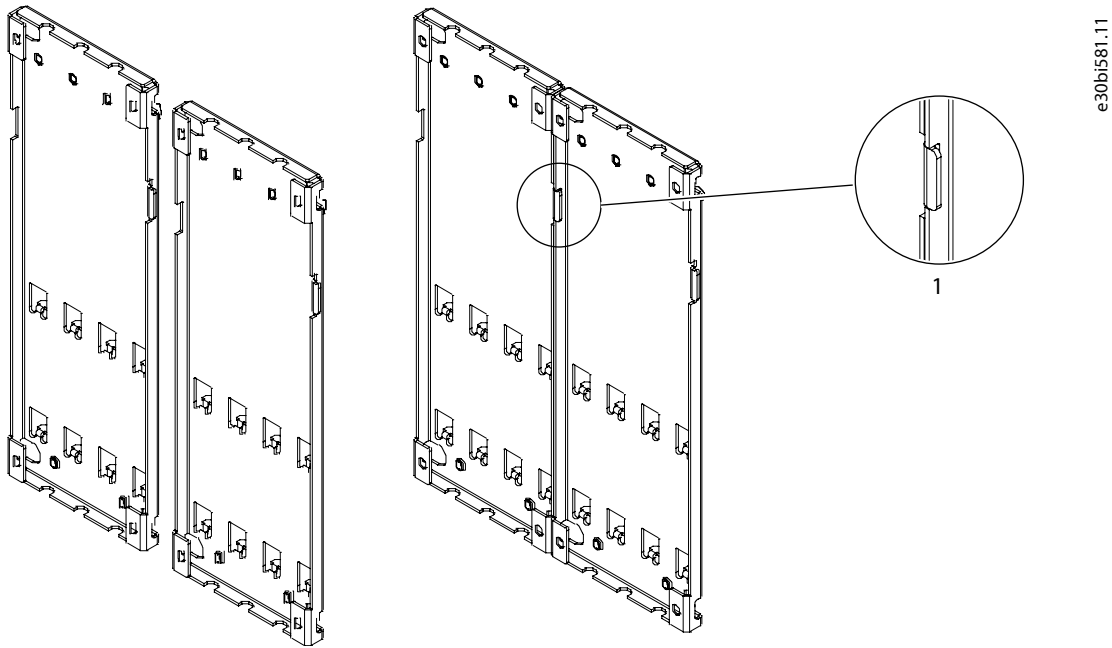

Figure 158: Attaching Mounting Plates to Each Other

1 Lip

2. Attach the mounting plates onto the cabinet with screws by the 4 mounting holes in the corners of the mounting plates.

The screws are not included in the delivery. Use an M4/M5 screw.

8.12 Installing the Control Unit

Install the control unit to the selected location. Use the 4 mounting holes in the corners of the mounting plate.

8.13 Installing Boards to the Modular Control Unit

NOTICE

DAMAGE TO OPTION BOARDS

Do not install, remove, or replace option boards on the drive when the power is on. Doing this can cause damage to the boards.

- Switch off the drive before installing, removing, or replacing option boards on the drive.

! IMPORTANT: It is recommended to install Option Extender OC7F2 in the 2nd slot on the right of the control unit.

1. Remove the screw that is pre-attached to the fixing point at the top of the mounting plate and keep it.
2. Slide the lower edge of the board to the mounting plate fixing point.

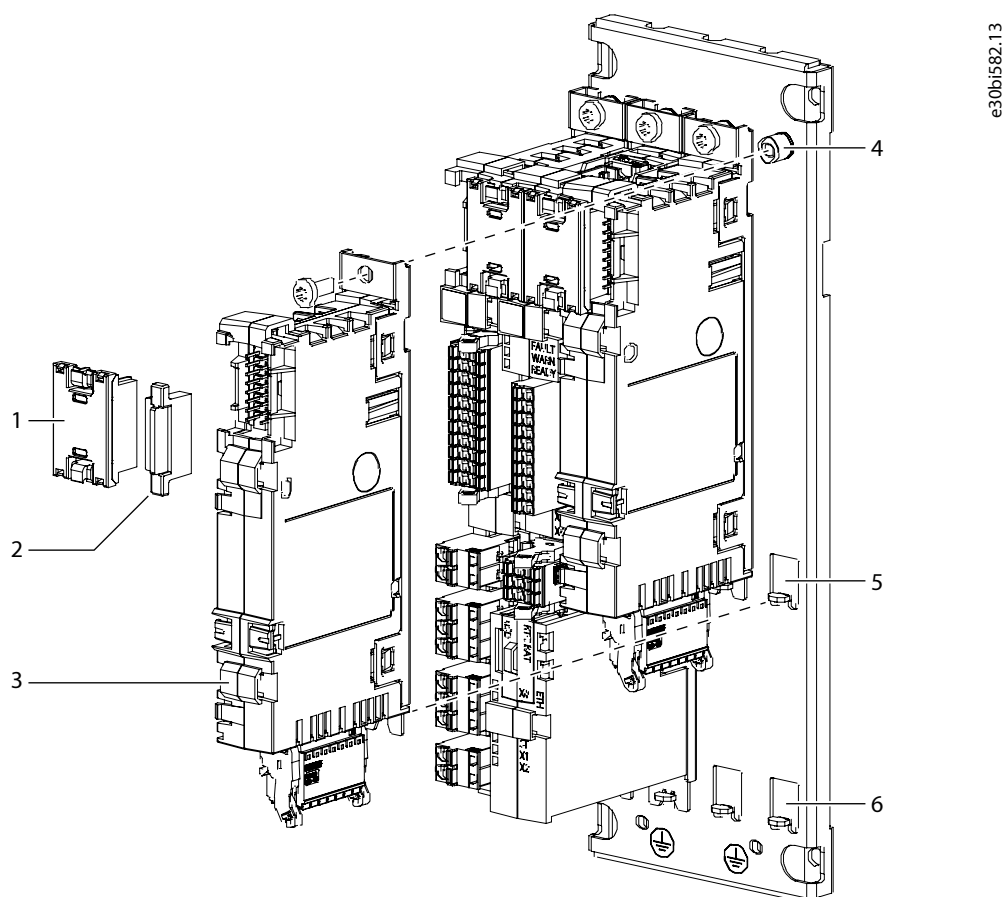

Figure 159: Installing a Board to the Modular Control Unit Mounting Plate

1	Option connector	2	Option terminal cover
3	Option board	4	Fixing point at the top
5	Fixing point at the middle	6	Fixing point at the bottom

3. Use the screw to attach the board to the fixing point at the top.
4. Attach an option connector to the installed board and the board next to it.
5. Attach option terminal covers to the empty terminals.

8.14 Connecting the Fieldbus Cable and the Fiber Cables

1. Connect the PLC to the Ethernet port X1 or X2 in the control board with a fieldbus cable.
2. Connect the terminal X80 in the control board to the terminal X90 in the star coupler board with a fiber cable.
3. Connect the terminals X301–X316 in the star coupler board to the power units with fiber cables.

Connect the star coupler board terminals to the power units in numerical order starting from X301. Do not skip terminals.

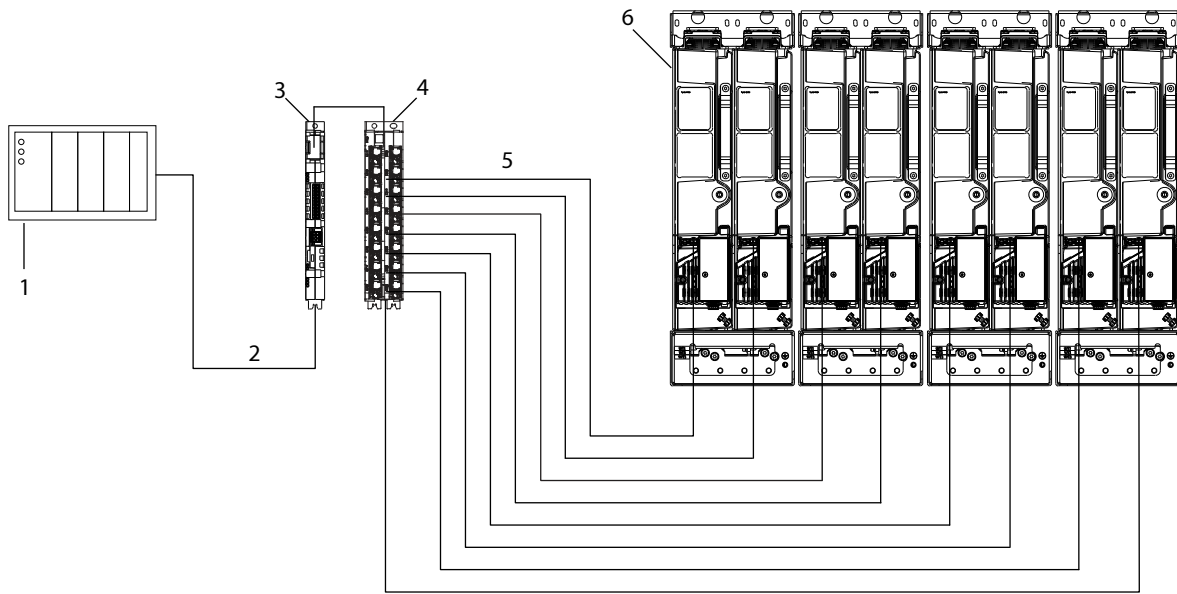

e30b1522.10

Figure 160: Connecting the Fieldbus Cable and the Fiber Cables

1	PLC (not included in the delivery)	2	Fieldbus cable
3	Control board	4	Star coupler board
5	Fiber cables	6	Power units

8.15 Installing the Control Cables into the Control Terminals

1. Install the control cables into the control terminals.

See the pin numbering of the I/O and Relay Option in [8.8 I/O and Relay Option \(OC7C1\) Connections](#).

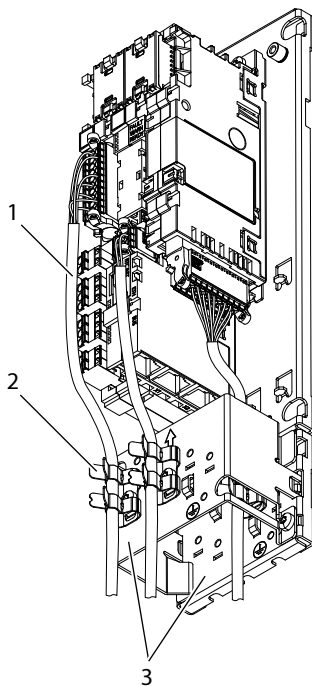

e30b1031.10

Figure 161: Example of Installing the Control Cables

1	Control cable	2	Cable clamp
3	Grounding plates		

2. Strip the control cables. Attach the control cables to the cable clamps on the suitable grounding plate.

The lower part of the cable clamp fixes the cable to the plate and provides strain relief. The upper part provides ~360° grounding for the cable shield.

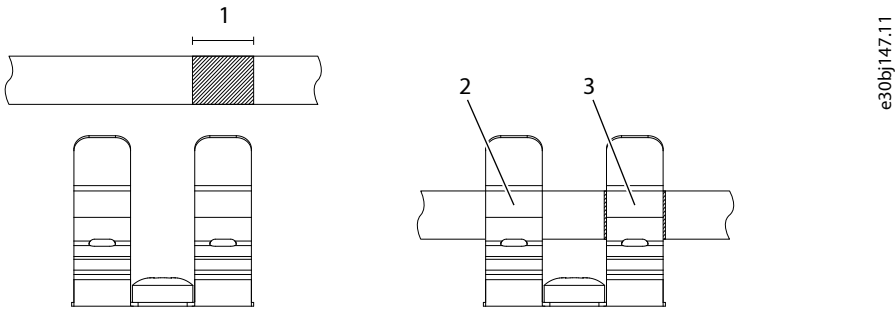

Figure 162: Stripping the Cable and Using the Grounding Plates

1	Stripping length, 10 mm (0.4 in)	2	Strain relief
3	Grounding		

8.16 Connecting the Control Panel

1. Connect the control panel to the terminal X9 in the modular control unit with a panel cable adapter.

8.17 Fiber Cable Requirements

The required fiber cable type is LC duplex cable assembly 0.5NA SI-POF.

The installation temperature of the fiber cable is -40...+85 °C (-40...+185 °F). The minimum bending radius is 25 mm (1.0 in).

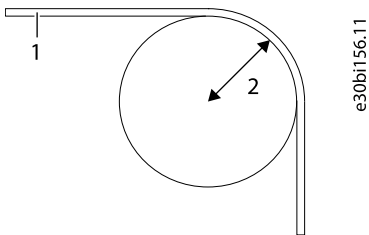

Figure 163: Bending Radius of the Fiber Cables

1	Cable	2	Bending radius (25 mm, 1.0 in)
---	-------	---	--------------------------------

9 Maintenance

9.1 Preventive Maintenance Recommendations

Generally, all technical equipment, including Danfoss drives need a minimum level of preventive maintenance. To ensure trouble-free operation and long life of the drive, regular maintenance is recommended. It is also recommended as a good service practice to record a maintenance log with counter values, date, and time describing the maintenance and service actions.

Danfoss recommends the following inspections and service intervals for liquid-cooled drives/systems.

NOTICE

The service schedule for part replacements can vary depending on operating conditions. Under specific conditions, the combination of stressful operation and environmental conditions work together to reduce the lifetime of the components significantly. These conditions can include, for example, extreme temperature, dust, high humidity, hours of use, corrosive environment, and loading.

For operation in stressful conditions, Danfoss offers the DrivePro® Preventive Maintenance service. DrivePro® services extend the lifetime and increase the performance of the product with scheduled maintenance including customized part replacements. DrivePro® services are tailored to the specific application and operating conditions.

Table 49: Maintenance Schedule for Liquid-cooled Drives

Component	Inspection interval ⁽¹⁾	Service schedule ⁽²⁾	Preventive maintenance actions
Installation			
Visual inspection	1 year	–	Check for the unusual, for example, for signs of overheating, aging, corrosion, and for dusty and damaged components.
Auxiliary equipment	1 year	According to manufacturer recommendations	Inspect equipment, switchgear, relays, disconnects, or fuses/circuit breakers. Examine the operation and condition for possible causes of operational faults or defects. The continuity check on fuses must be performed by trained service personnel.
EMC consideration	1 year	–	Inspect the wiring regarding the electromagnetic capability and the separation distance between control wiring and power cables.
Cable routing	1 year	–	Check for parallel routing of motor cables, mains wiring, and signal wiring. Avoid parallel routing. Avoid routing cables through free air without support. Check for aging and wearing of the cable insulation.
Control wiring	1 year	–	Check for tightness, damaged or crimped wires, or ribbon wires. Terminate the connections correctly with solid crimped ends. The use of shielded cables and grounded EMC plate, or a twisted pair is recommended.
Clearances	1 year	–	Check that the external clearances for proper airflow for cooling follow the requirements for the frame and product type. For clearances, refer to the local design regulations.
Sealing	1 year	–	Check that the sealing of the enclosure, the covers, and the cabinet doors are in good condition.
Corrosive environments	1 year	–	Conductive dust and aggressive gases, such as sulphide, chloride, and salt mist, can damage the electrical and mechanical components. Air filters do not remove airborne corrosive chemicals. Act based on the findings.
Drive			

Table 49: Maintenance Schedule for Liquid-cooled Drives - (continued)

Component	Inspection interval ⁽¹⁾	Service schedule ⁽²⁾	Preventive maintenance actions
Programming	1 year	–	Check that the drive parameter settings are correct according to the motor, drive application, and I/O configuration. Only trained service personnel are allowed to perform this action.
Control panel	1 year	–	Check that the display pixels are intact. Check the event log for warnings and faults. Repetitive events are a sign of potential issues. If necessary, contact a local service center.
Drive cooling capacity	1 year	–	Check for blockages or constrictions in the air passages of the cooling channel. The heat sinks must be free of dust and condensation.
Capacitors, DC link	1 year	8–15+ years	The expected lifetime of the capacitors depends on the loading profile of the application and the ambient temperature. If within the specifications of the drive type, replace the capacitors every 10–15+ years. Only trained service personnel are allowed to perform this action.
Cleaning and filters	1 year	–	Clean the interior of the enclosure annually, and more frequently if necessary. The amount of dust in the filter or inside the enclosure is an indicator for when the next cleaning or filter replacement is required.
Fans	1 year	5–10 years	Inspect the condition and operational status of all cooling fans. With the power off, the fan axis should feel tight, and spinning the fan with a finger, the rotation should be almost silent and not have abnormal rotation resistance. When in RUN mode, fan vibration, excessive or strange noise is a sign of the bearings wearing, and the fan must be replaced.
Grounding	1 year	–	The drive system requires a dedicated ground wire connecting the drive, the output filter, and the motor to the building ground. Check that the ground connections are tight and free of paint or oxidation. Daisy-chain connections are not allowed. If applicable, braided straps are recommended.
PCB	1 year	10–12 years	Visually inspect the printed circuit boards for signs of damage or degrading due to aging, corrosive environments, dust, or environments with high temperatures. Only trained service personnel are allowed to perform the inspection and service action.
Power cables and wiring	1 year	–	Check for loose connections, aging, insulation condition, and proper torque to the drive connections. Check for proper rating of fuses and continuity check. Observe if there are any signs of operation in a demanding environment. For example, discoloration of the fuse housing can be a sign of condensation or high temperatures.
Vibration	1 year	–	Check for abnormal vibration or noise coming from the drive to ensure that the environment is stable for electronic components.
Insulator gaskets	1 year	10–15 years	Inspect the insulators for signs of degradation due to high temperature and aging. Replacement is based on findings or done at the same time as DC capacitor replacement. Only trained service personnel are allowed to perform this action.
Batteries	1 year	7–10 years	Replace the batteries according to the manufacturer recommendation. Replace the real-time clock battery in the control unit every 7–10 years.
Spare parts			
Spare parts	1 year	2 years	Stock spares in their original boxes in a dry and clean environment. Avoid hot storage areas.
Exchange units	1 year	2 years	Visually inspect for signs of damage, water, high humidity, corrosion, and dust within the visual field of view without disassembly.

Table 49: Maintenance Schedule for Liquid-cooled Drives - (continued)

Component	Inspection interval ⁽¹⁾	Service schedule ⁽²⁾	Preventive maintenance actions
Coolant			
Log	Commissioning/startup, or when replacing coolant	–	To create a baseline for future reference before and after adding inhibitor and glycol, record the water quality specification values. Also, record the system pressure, coolant flow rate, and temperature range.
Glycols	1 year	Based on findings	Measure and record the level of glycol in the cooling system. The minimum concentration level is always 75/25% demineralized water/glycol.
Corrosive inhibitors	1 year	Based on findings	Measure and record the level of Danfoss recommended corrosive inhibitor (Cortec-VpCl-649) in the liquid coolant (see specification). Measure the level of the inhibitor every year. If the inhibitor level is below the recommended level of 1%, add more inhibitor.
Pre-mixed coolant with glycol and inhibitor	1 year	Based on findings	The pre-mixed coolants contain specific percentages of glycol and inhibitor for antifreeze and corrosion protection. The advantage of using a pre-mixed coolant is that the chemical composition is within Danfoss specifications, and there is no need for analyzing the coolant.
Demineralized water	1 year	Based on findings	Only use demineralized or deionized water in the coolant solution. Record and compare the chemical composition values when replacing or adding coolant.
Liquid-cooling system			
Pipes, hoses, and connections	1 year	1 year	Check for external signs of moisture, corrosion, and coolant leaks. Check the tightness of the cooling pipe connections. Check the heat sinks and host pipes in the cooling system.
Leak detector	1 year	10 years	Test the functioning of the leak detector.
Power unit heat sinks	1 year	6 years	Check that the heat sink temperature across all cooling circuits or power phases is balanced. Imbalanced temperature of the cooling circuits is a possible sign of a restriction. Under normal conditions, clean or acid-wash the heat sinks every 6 years with Danfoss recommended cleaning products. Refill the coolant system and log the new coolant specification values.
Auxiliary equipment	1 year	According to manufacturer recommendations	Check that the sensors, gauges, and indicators are functioning correctly. Act based on the findings.
System cooling capacity	1 year	Based on findings	Test the cooling capacity and the thermal transfer of the system. Record the coolant system flow, pressure, and input and output temperature, and compare to the previous measurements. Act based on the findings.

1) Defined as the time after the commissioning/startup or the time from the previous inspection.

2) Defined as the time after the commissioning/startup or the time from the previous service schedule actions.

9.2 Maintenance Log for Cooling System

During the commissioning phase of the product and during each inspection refer to the maintenance schedule. Record values such as the ambient air temperature, system pressure, flow, and input/output cooling liquid temperature during run condition. Record the water chemical analysis values and the type and percentages of glycol and inhibitor or pre-mixed solutions of the liquid coolant.

The initial values create a base-line value to compare versus future values measured during preventive maintenance intervals. Record the chemical analysis values each time the liquid coolant is replaced. Record all the maintenance tasks and service tasks with counter values, date, and time.

9.3 Using the Product Modified Label

In the accessories bag, there is also a "product modified" label. The function of the label is to tell the service personnel about the changes that are made in the drive.

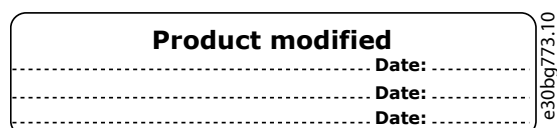

Figure 164: The Product Modified Label

1. Attach the label on the side of the drive, in a place where it is easy to find.
 - a. Attach the label, for example, next to the other labels on the power unit.
2. If changes are made to the drive, write the change and date on the label.

9.4 Replacing the RTC Battery

The real-time clock (RTC) battery can be used to provide a reliable power source for the RTC. If power is lost in the control unit, the RTC battery keeps the internal real time. The time is used for scheduled activities and timestamping occurrences based on application needs. The RTC battery is optional and comes preinstalled if the option is selected.

CAUTION

RISK OF FIRE AND EXPLOSION

- Replace the battery with either a Panasonic BR1632A (3 V, 125 °C), Jauch Quartz CR1632 (246335) (3 V, 85 °C), or Renata Batteries CR1632 (3 V, 85 °C) coin-cell battery only. Using another battery may present a risk of fire or explosion. Only qualified personnel can exchange the battery.
- For detailed safety information, refer to the documentation provided with the battery.

CAUTION

RISK OF FIRE OR EXPLOSION

- Do not recharge or disassemble the battery, or dispose of it in fire.

1. Locate the RTC battery holder on the control board of the control unit.
2. Pull from the handle next to the text RTC BAT.

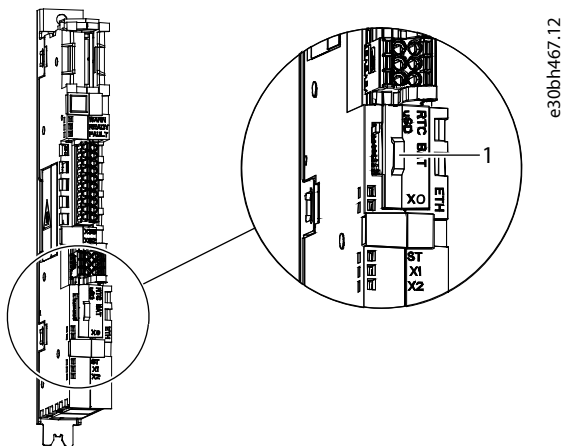

Figure 165: Location of the RTC Battery

1 The handle

➡ The battery holder slides out.

- To remove the battery, push it on the tooth side and slide it out of the plastic holder.

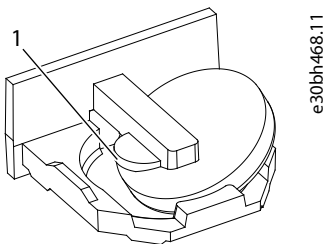

Figure 166: Replacing the Battery

1 The tooth

- To put a new battery in place, start from the opposite side and slide it into the slot in the holder, the plus side towards the tooth.

The correct battery type is a coin type lithium battery.

- Push the holder back into the control board.

9.5 Removing the System Module from the Integration Unit

These instructions apply to xR10L and xR12L system modules with integration units. The system module shown in the illustrations is an IR10L.

- If removing power unit 1 from a system module lineup, remove the detachable product label plate from the front of power unit 1.
 - To release the product label plate, remove the M4x8 screw (141N2502) with a TX20 bit.
 - Keep the product label plate with the product. Install the plate on the new power unit.

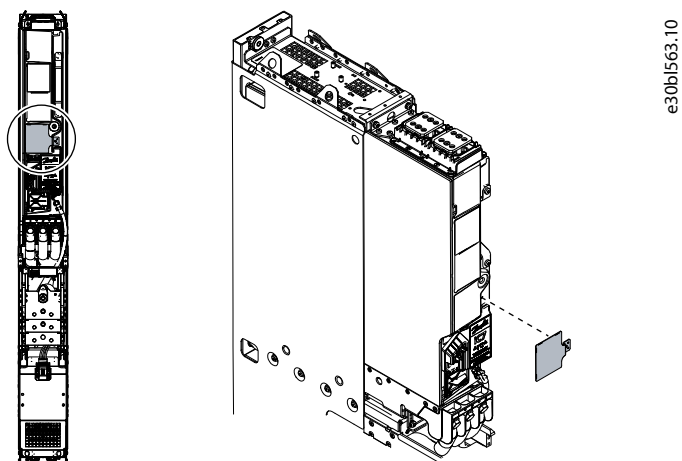

Figure 167: Mounting Location of the Product Label Plate

2. Disconnect the cables from the system module.
 - a. Disconnect the optical fiber cable from control terminal X81.
 - b. Disconnect the AuxBus cable from terminal X79.
 - c. Disconnect the power cables.

The power cables are mounted with M10x30 mounting bolts (141N9277). To remove the bolts, use a 17 mm (0.67 in) bit. The tightening torque of the bolts is 35 Nm (310 in-lb).

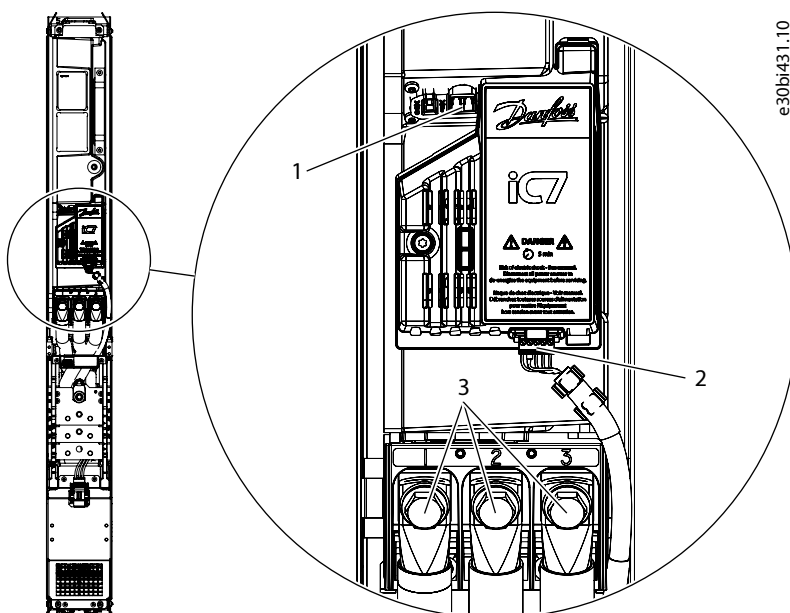

Figure 168: Disconnecting the Cables from the System Module

- | | |
|------------------------------|-----------------------|
| 1 Control terminal X81 | 2 AuxBus terminal X79 |
| 3 Power cable mounting bolts | |

3. Release the fuses from the DC busbars. Remove the two M10x25 screws (141L3598) from each fuse.

See [Figure 94](#).

4. Release the handle on the front of the system module and install it so that it can be used to move the module.

The handle is mounted with two 6x12 screws (141N2374). Use a TX30 bit to release and mount the screws. Tighten the screws to torque 5 Nm (44 in-lb).

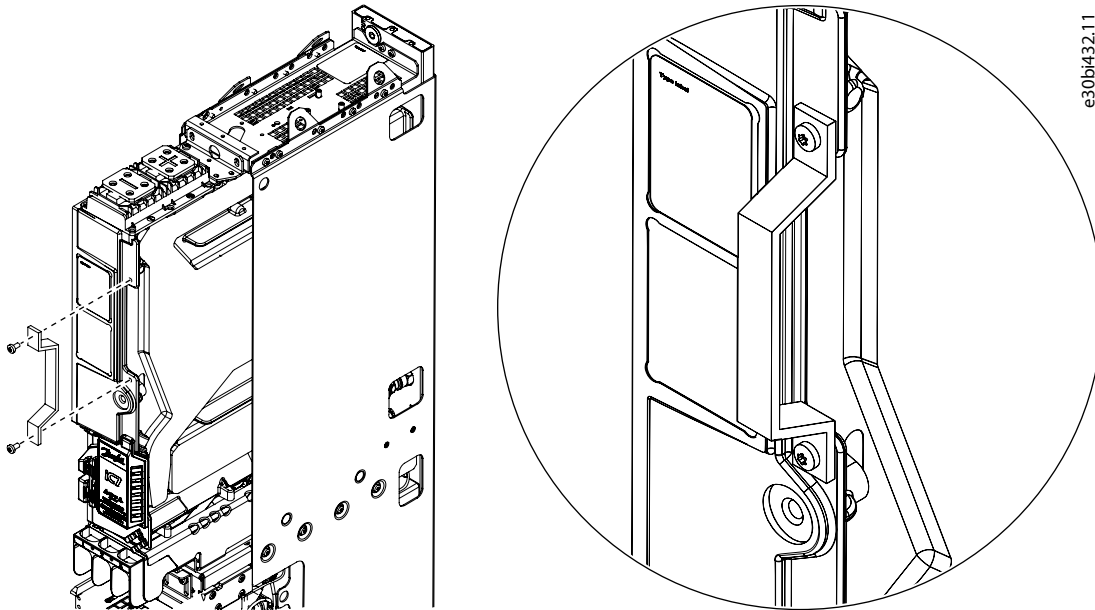

Figure 169: The Handle on the System Module

- Remove the 2 size M6x16 screws (141L3015) at the top of the system module.

Use a TX30 bit to remove the screws. The tightening torque of the screws is 5 Nm (44 in-lb).

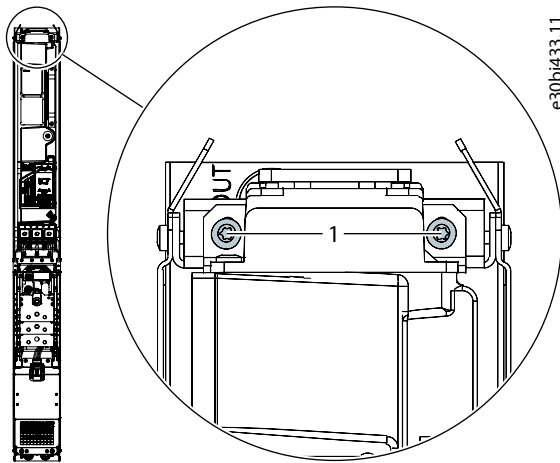

Figure 170: System Module Mounting Screws

- | | |
|---|-----------------|
| 1 | Mounting screws |
|---|-----------------|

- Release the module locking plate and slide it down to release the system module.

Loosen the 5 size M6x16 screws (141L3015) on the module locking plate. Use a TX30 bit. The tightening torque of the screws is 5 Nm (44 in-lb).

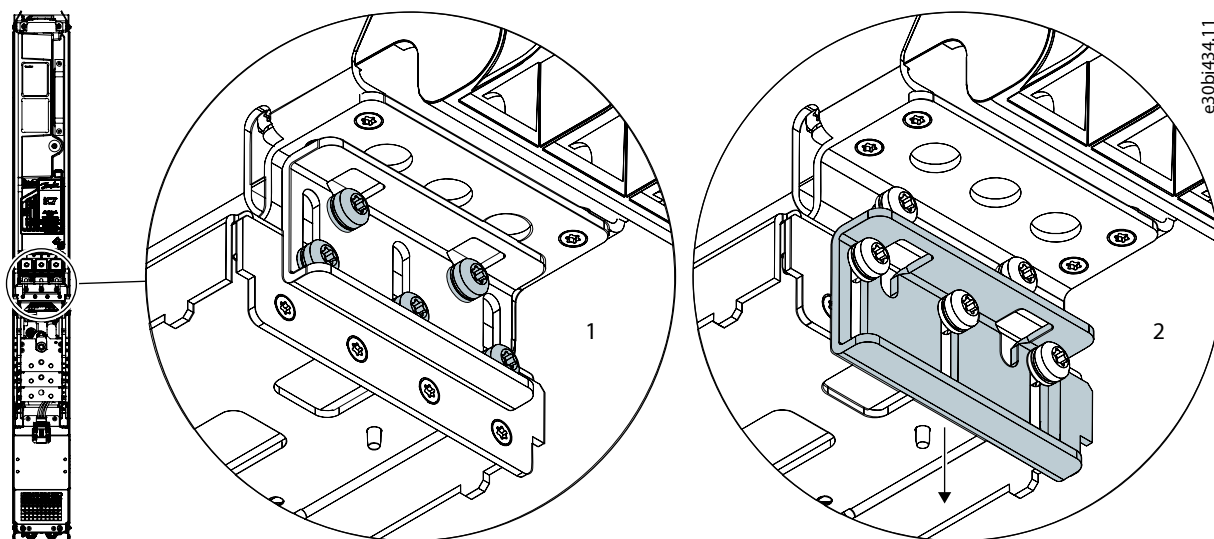

Figure 171: Releasing the Locking Plate

- | | |
|---------------------------|--------------------------------------|
| 1 Loosen the screws. | 2 Slide down the locking plate. |
|---------------------------|--------------------------------------|

7. If necessary, use a lifting device to lift the system module. Attach the lifting device on the top of the system module and use the handle to pull the module out from the integration unit.

The weight of the system module is approximately 40 kg (88 lb).

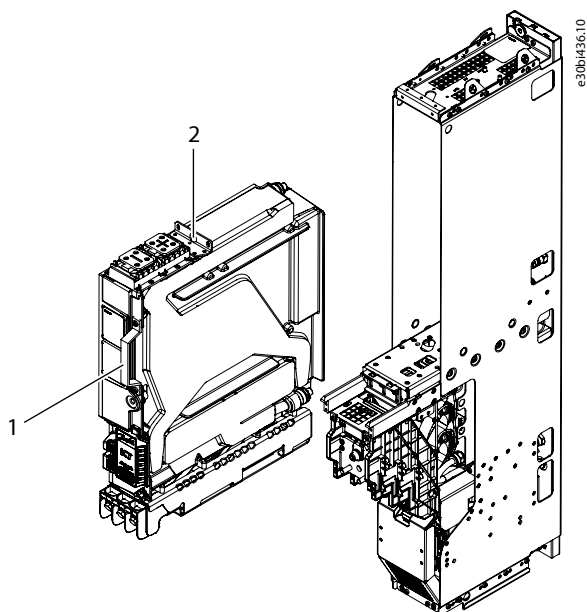

Figure 172: Lifting the System Module from the Integration Unit

- | | |
|---------------|----------------------|
| 1 Handle | 2 Lifting point |
|---------------|----------------------|

8. Drain the system module before storage or transportation.

NOTICE

When the system module is removed, the cooling circuit is filled with coolant. The coolant in the cooling channels can expand because of a change in temperature or due to a chemical reaction. If the module is not drained, the expanding coolant can break the components in the module.

- Always drain the system module before storage or transportation.

See [9.7.2 Draining the Power Units for xR10L and xR12L](#).

9.6 Installing the System Module in the Integration Unit

Prerequisites:

NOTICE

MODULE COMPATIBILITY

Do not install modules with different configurations in the same drive system.

1. If necessary, use a lifting device to lift the system module in the integration unit. Attach the lifting device on the top of the system module and use the handle to move the module and push it in the integration unit.

The weight of the system module is approximately 40 kg (88 lb).

See the lifting points in [Figure 172](#).

2. To make sure that the push-in cooling connectors at the back of the system module are connected properly, push the system module all the way to the back of the integration unit.

The cooling connectors are visible from the sides of the integration unit.

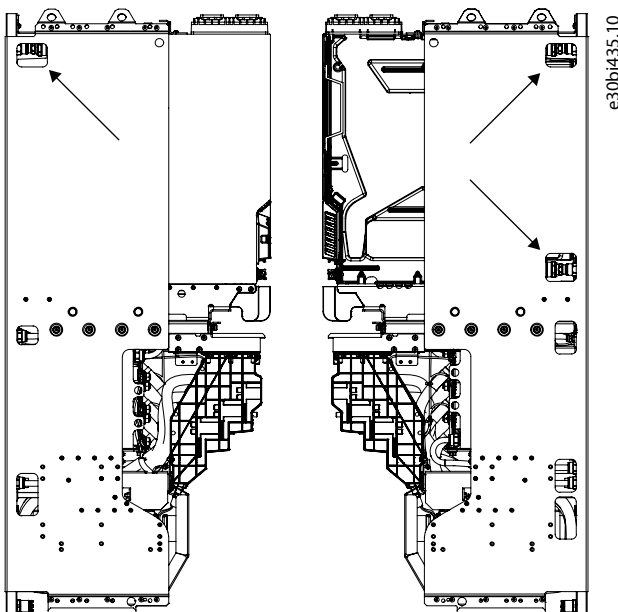

Figure 173: Cooling Connectors on the System Module

3. Slide up the module locking plate and fix it on the system module.

Tighten the 5 size M6x16 screws (141L3015) on the module locking plate. Use a TX30 bit and tighten the screws to torque 5 Nm (44 in-lb). See [Figure 171](#).

4. Mount the system module on the integration unit with 2 size M6x16 screws (141L3015) at the top part of the system module.

Use a TX30 bit to mount the screws. Tighten the screws to torque 5 Nm (44 in-lb). See [Figure 170](#).

5. Release the handle on the front of the system module and install it so that it is facing the module.

The handle is mounted with two 6x12 screws (141N2374). Use a TX30 bit to release and mount the screws. Tighten the screws to torque 5 Nm (44 in-lb). See [Figure 169](#).

6. Install DC fuses on the DC busbars. Use two M10x25 screws (141L3598) on each fuse.

See [Figure 94](#).

7. Connect the cables on the system module.
 - a. Connect the optical fiber cable to control terminal X81.
 - b. Connect the AuxBus cable to terminal X79.
 - c. Connect the power cables.

Mount the power cables with M10x30 mounting bolts (141N9277). Use a 17 mm (0.67 in) bit to tighten the bolts to torque 35 Nm (310 in-lb).

See [Figure 168](#).

8. Check that the cables are not pinned between the system module and the frame of the integration unit.
9. If the product label plate was removed from power unit 1, mount it on the new power unit.
 - a. Mount the product label plate with a M4x8 screw (141N2502). Use a TX20 bit to tighten the screw to torque 2 Nm (18 in-lb).

See [Figure 167](#).

9.7 Draining the System Modules

9.7.1 Draining the System Modules, System Modules with Integration Units, and Filters

To prevent damage to the equipment, always drain the system modules and filters before storage or transportation.

Required for the draining procedure:

- Container large enough for the drained coolant. 1 system module can hold 0.55 l of coolant.
- Pressurized air can be used for the draining. Maximum pressure is 5 bar (72.5 psi).
- Dust caps or tape.
 1. Close the valves of the system module to be drained.
 2. Place the container below the coolant inlet and outlet.
 3. Disconnect the coolant outlet and inlet hoses from the main manifold and drain the coolant to the container.
 4. To drain all the coolant from the module, supply pressurized air to the outlet connector.
 5. After all the coolant is drained, remove the system module from the cabinet.
 6. Before storage or transportation, plug the coolant inlet and outlet connectors.

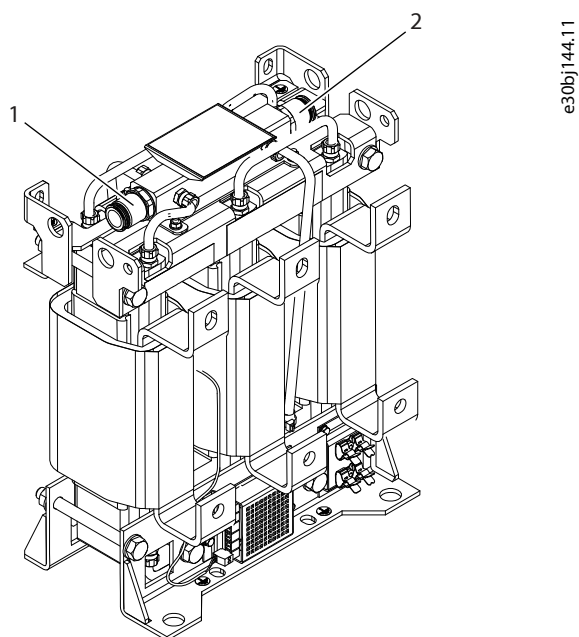

Figure 176: Inlet and Outlet Connectors of the L Filter

1	Inlet/outlet connector	2	Inlet/outlet connector
---	------------------------	---	------------------------

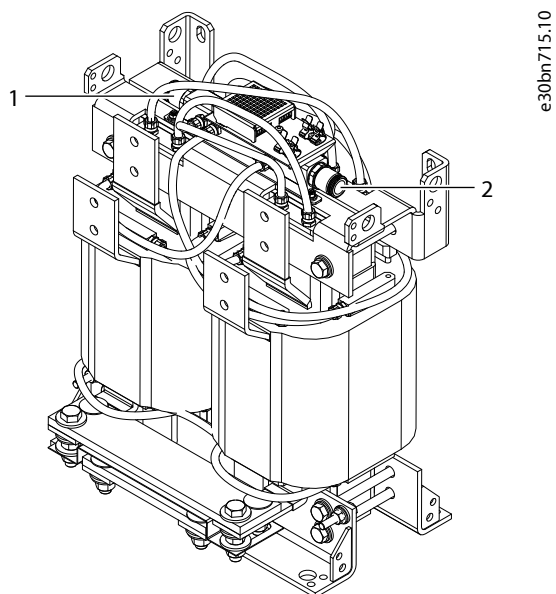

Figure 177: Inlet and Outlet Connectors of the SISO Filter

1	Inlet/outlet connector	2	Inlet/outlet connector
---	------------------------	---	------------------------

9.7.2 Draining the Power Units for xR10L and xR12L

To prevent damage to the equipment, always drain the power units before storage or transportation.

Required for the draining procedure:

- Tools for opening the quick-release connectors of the coolant inlet and outlet.
- Container large enough for the drained coolant. 1 system module can hold 0.55 l of coolant.

- To perform the procedure easily, 2 people are required.
- Pressurized air can be used for the draining. Maximum pressure is 5 bar (72.5 psi).
 1. Remove the power unit from the integration unit.
 2. Place the power unit in a vertical position and place the container below the coolant inlet at the bottom of the module.
 3. To open the quick-release connectors of the coolant outlet and inlet, push in the valves with a blunt tool.

Do not insert sharp or hard metallic objects in the connectors. Sharp objects can damage the connectors or the sealing inside the connectors.

4. Drain the coolant to the container. To drain all the coolant:
 - Tilt the module, or
 - Supply pressurized air to the outlet connector.
5. Dispose of the coolant according to local laws and regulations.

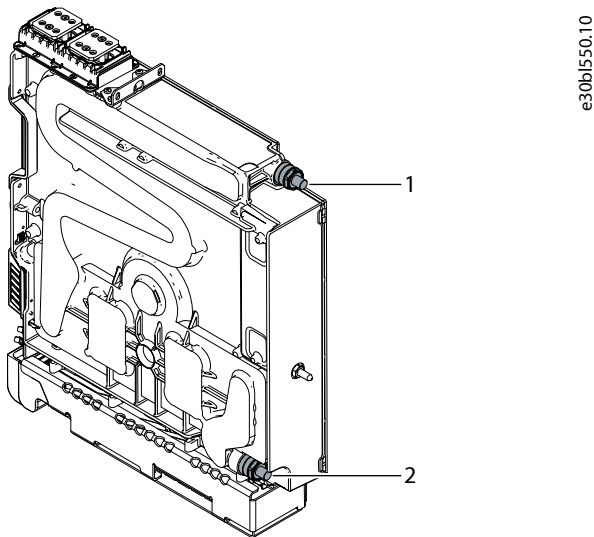

Figure 178: Inlet and Outlet Connectors of Power Units for xR10L and xR12L

1 Outlet connector	2 Inlet connector
-------------------------	------------------------

10 Specifications

10.1 Tightening Torques

Table 50: Tightening Torques and Bolt Lengths of the Terminals

Bolt	Tightening torque [Nm]	Maximum length of bolt under the busbar [mm]	Tightening torque [in-lb]	Maximum length of bolt under the busbar [in]
M4	2–2.5	–	18–22	–
M5	3–4	–	27–35	–
M6	6–9	–	53–80	–
M8	17–20	10	150–177	0.39
M10	35–40	22	310–354	0.87
M12	65–70	22	575–620	0.87
Grounding bolt (M8)	17–20	20	150–177	0.79

Table 51: Tightening Torques of Fuses

Fuse size	Tightening torque [Nm]	Tightening torque [in-lb]	Stud maximum torque [Nm]	Stud maximum torque [in-lb]	Stud	Bolt
31	13.5 +0/-2	119 +0/-17	10	88	M8x30 Zn DIN913	–
44	26 +0/-2	230 +0/-17	–	–	–	M10x20 DIN933-8.8-Zn
73	46 +0/-4	407 +0/-35	15	132	M12x35 Zn DIN913	–

10.2 Dimensions

10.2.1 Dimensions of the Inverter Module, IM10L, AFE/GC Module, AM10L, DC/DC Converter Module, DM10L, and, BCU, BR10L

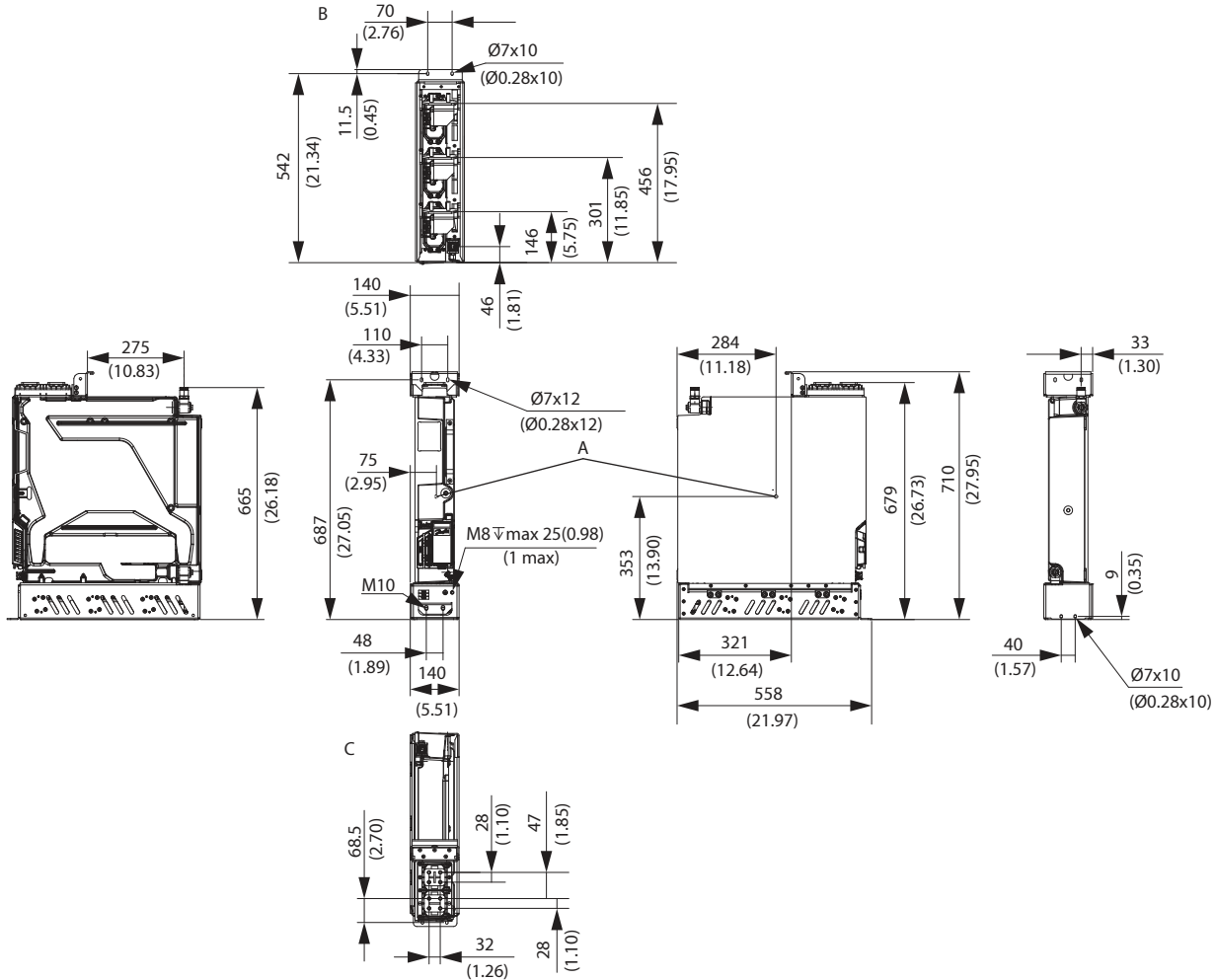

e30bh473.10

Figure 179: Dimensions of INU, IM10L, AFE/GC, AM10L, DC/DC Converter, DM10L and, BCU, BR10L in mm (in)

A	The center of gravity	B	View from the bottom
C	View from the top		

10.2.2 Dimensions of the System Modules with Short Integration Units (+AE01) IR10/AR10L/DR10L/BR10L

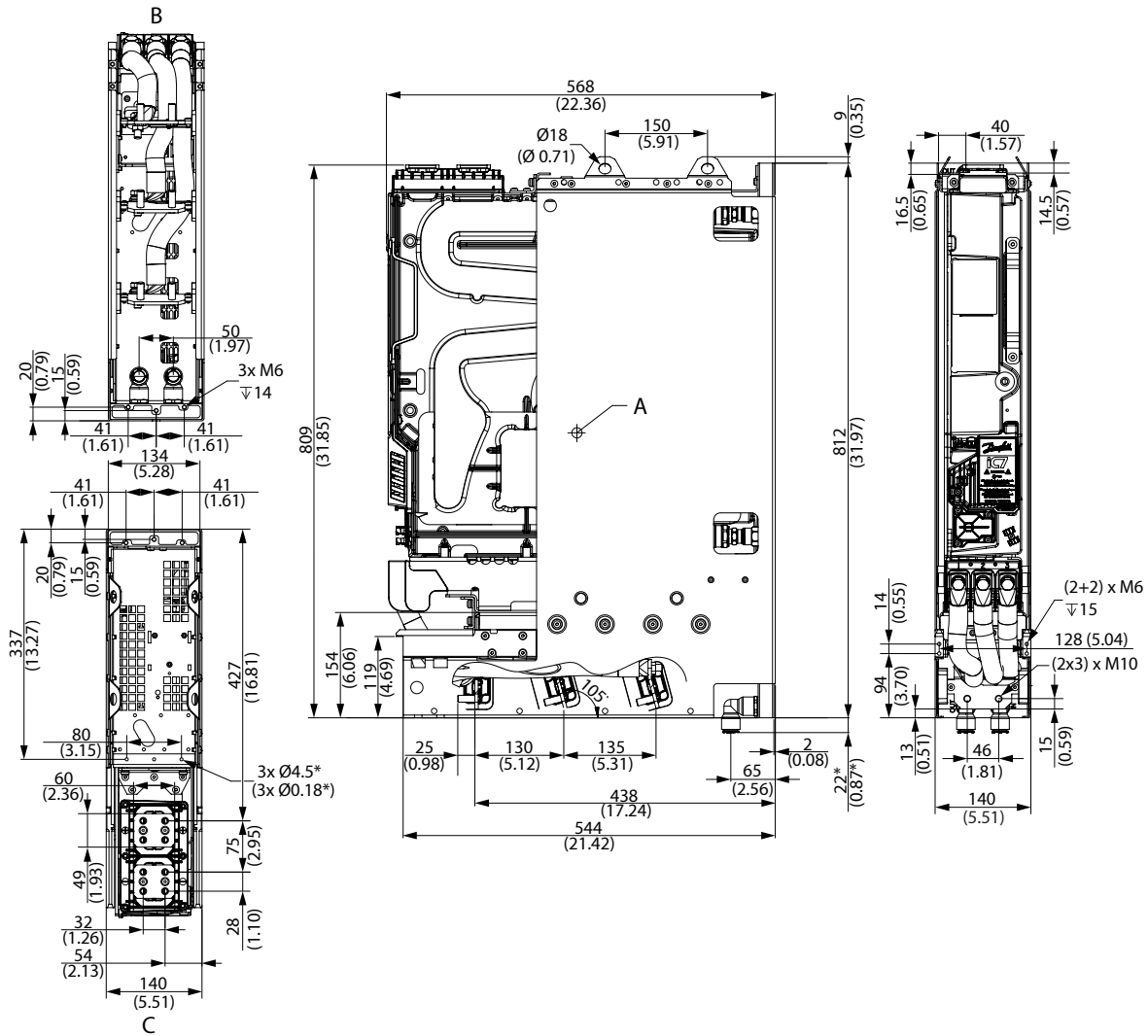

e-30bn555.10

Figure 180: Dimensions of (+AE01), IR10/AR10L/DR10L/BR10L, in mm (in)

- A Center of gravity
- B View from the bottom
- C View from the top

NOTE: 22*: The fittings are turnable. When delivered, the fittings are oriented with the pipe port facing upwards.

NOTE: 3x Ø4.5*: For M5 thread-forming screws.

10.2.3 Dimensions of the Inverter Module, IR10L

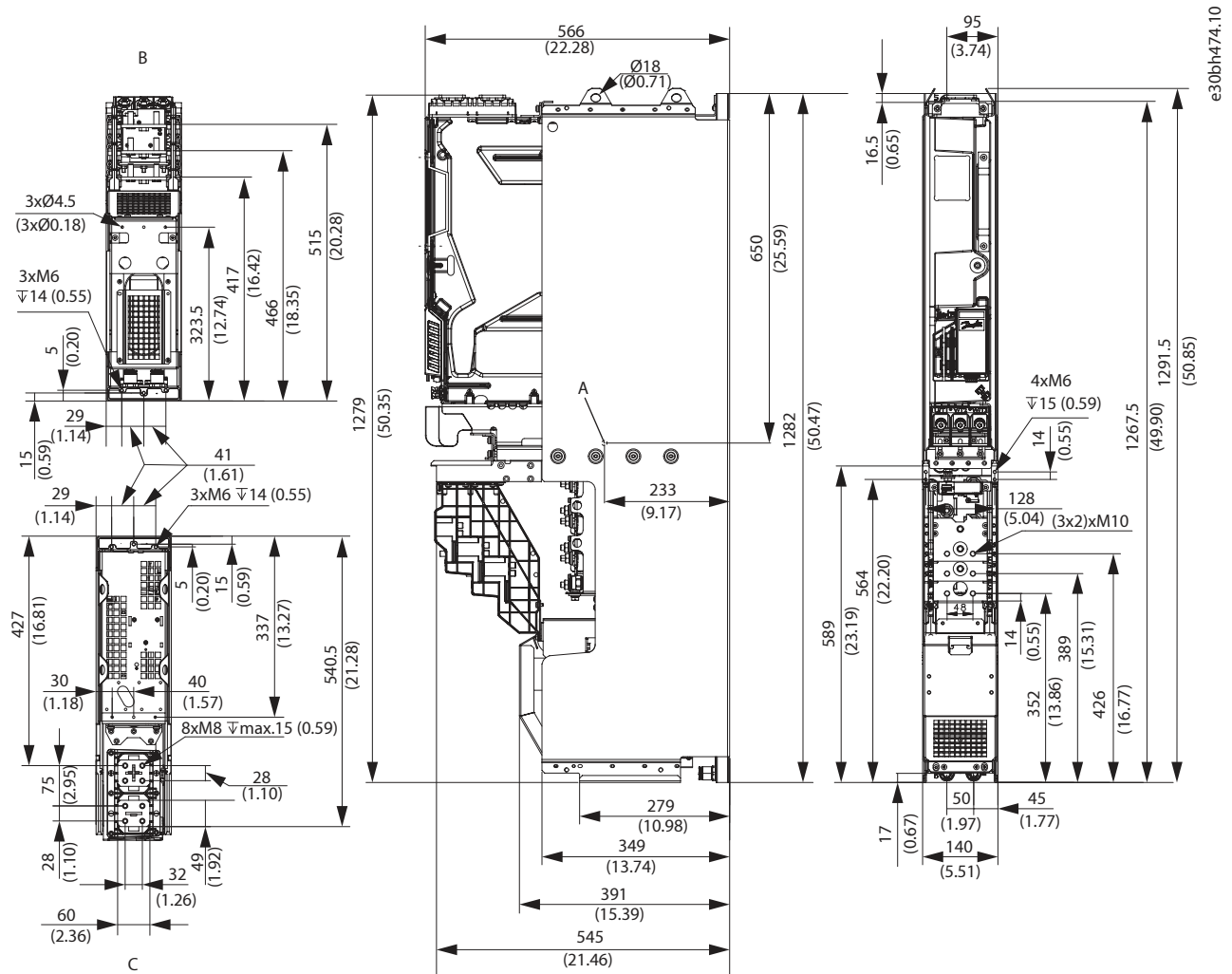

Figure 181: Dimensions of INU, IR10L, in mm (in)

- A Center of gravity
- B View from the bottom
- C View from the top

10.2.4 Dimensions of the Active Front-end Module/Grid Converter, AR10L

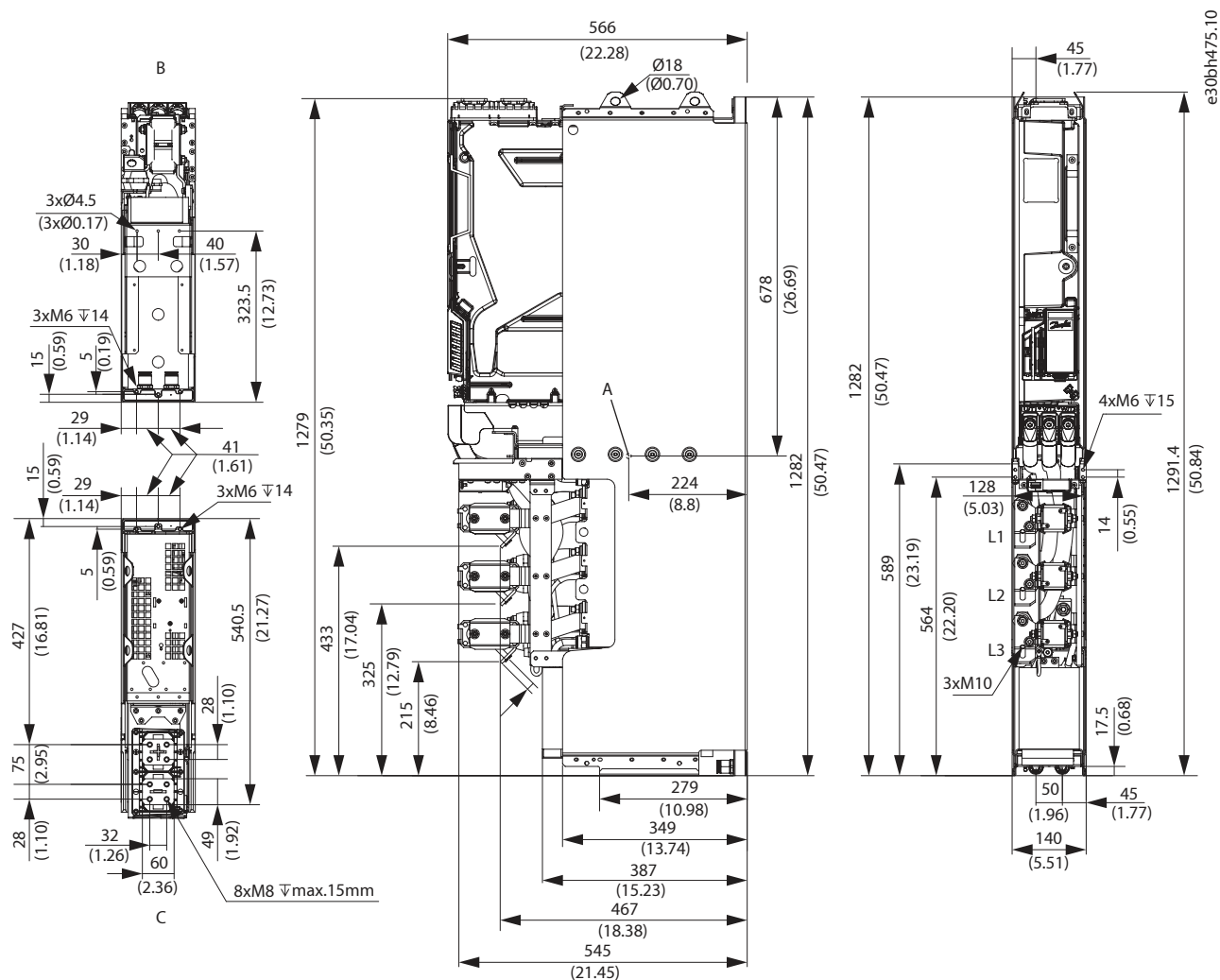
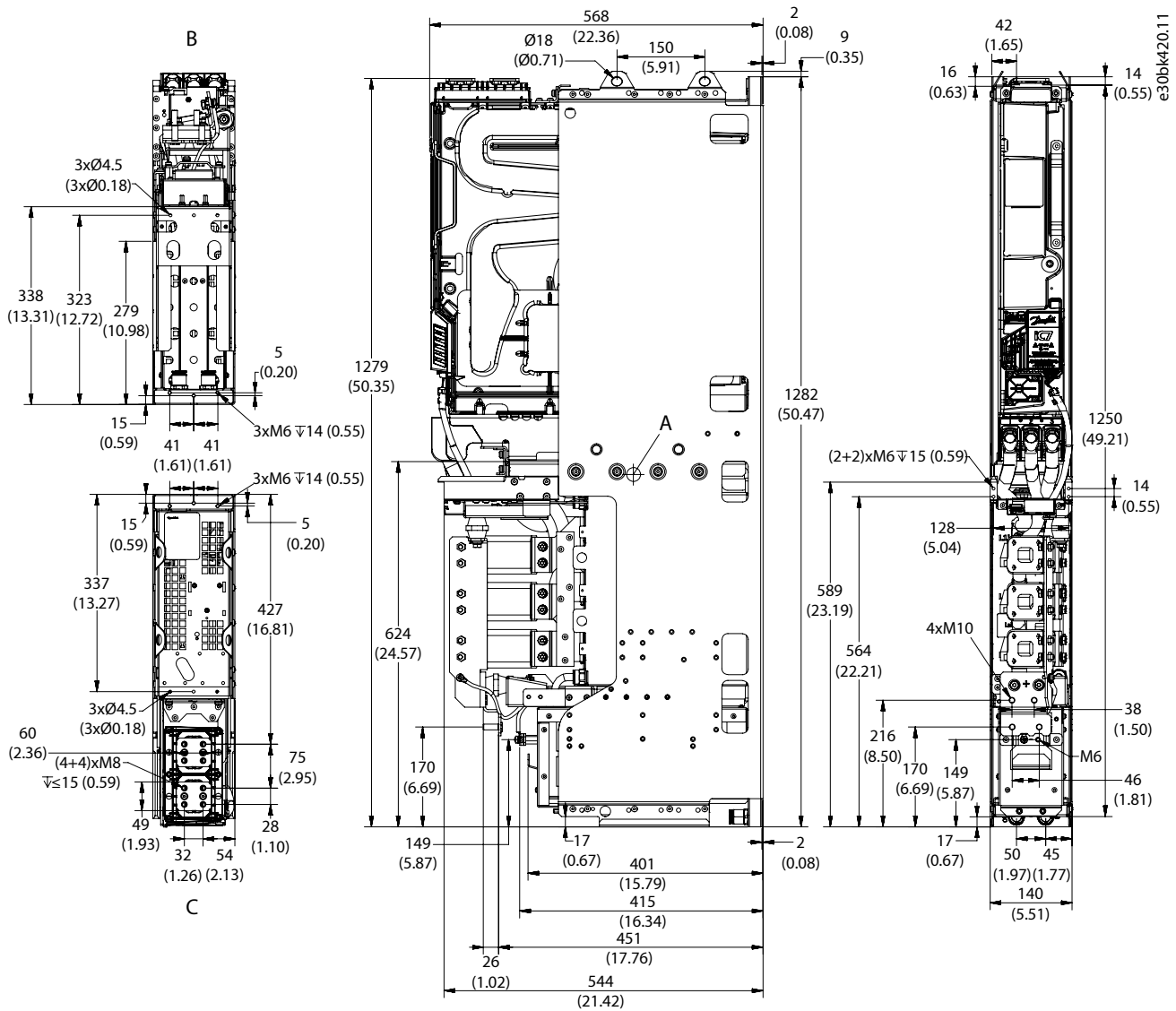

Figure 182: Dimensions of AFE/GC, AR10L, in mm (in)

- A The center of gravity
- B View from the bottom
- C View from the top

10.2.5 Dimensions of the DC/DC Converter, DR10L



- | | | | |
|---|-------------------|---|----------------------|
| A | Center of gravity | B | View from the bottom |
| C | View from the top | | |

10.2.6 Dimensions of the Inverter Module, IM12L, AFE/GC Module, AM12L, DC/DC Converter Module, DM12L and, BCU, BR12L

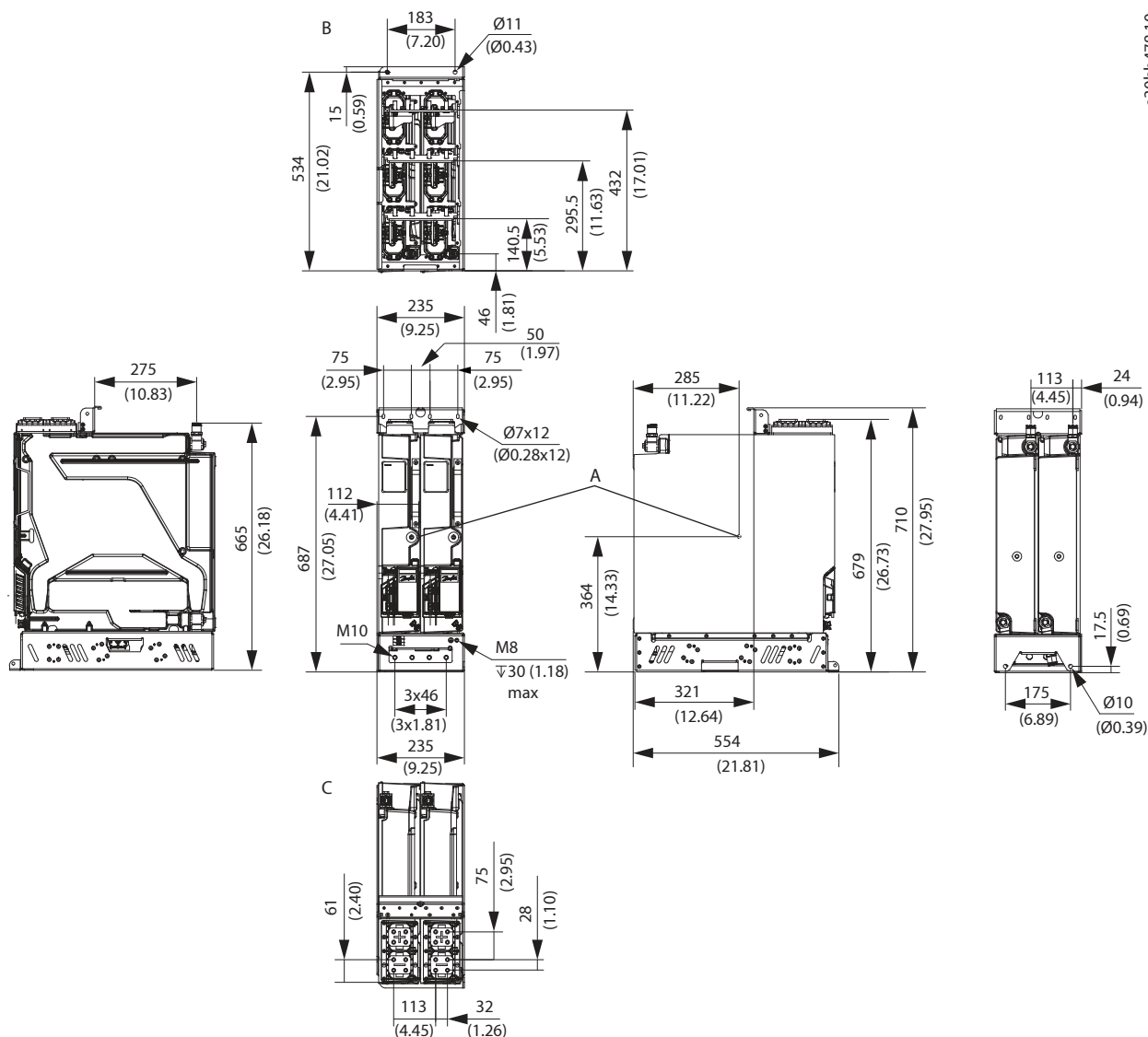

e30bh478.10

Figure 184: Dimensions of INU, IM12L, AFE/GC, AM12L, DC/DC Converter, DM12L and, BCU, BR12L in mm (in)

A	Center of gravity	B	View from the bottom
C	View from the top		

10.2.8 Dimensions of the Inverter Module, IR12L

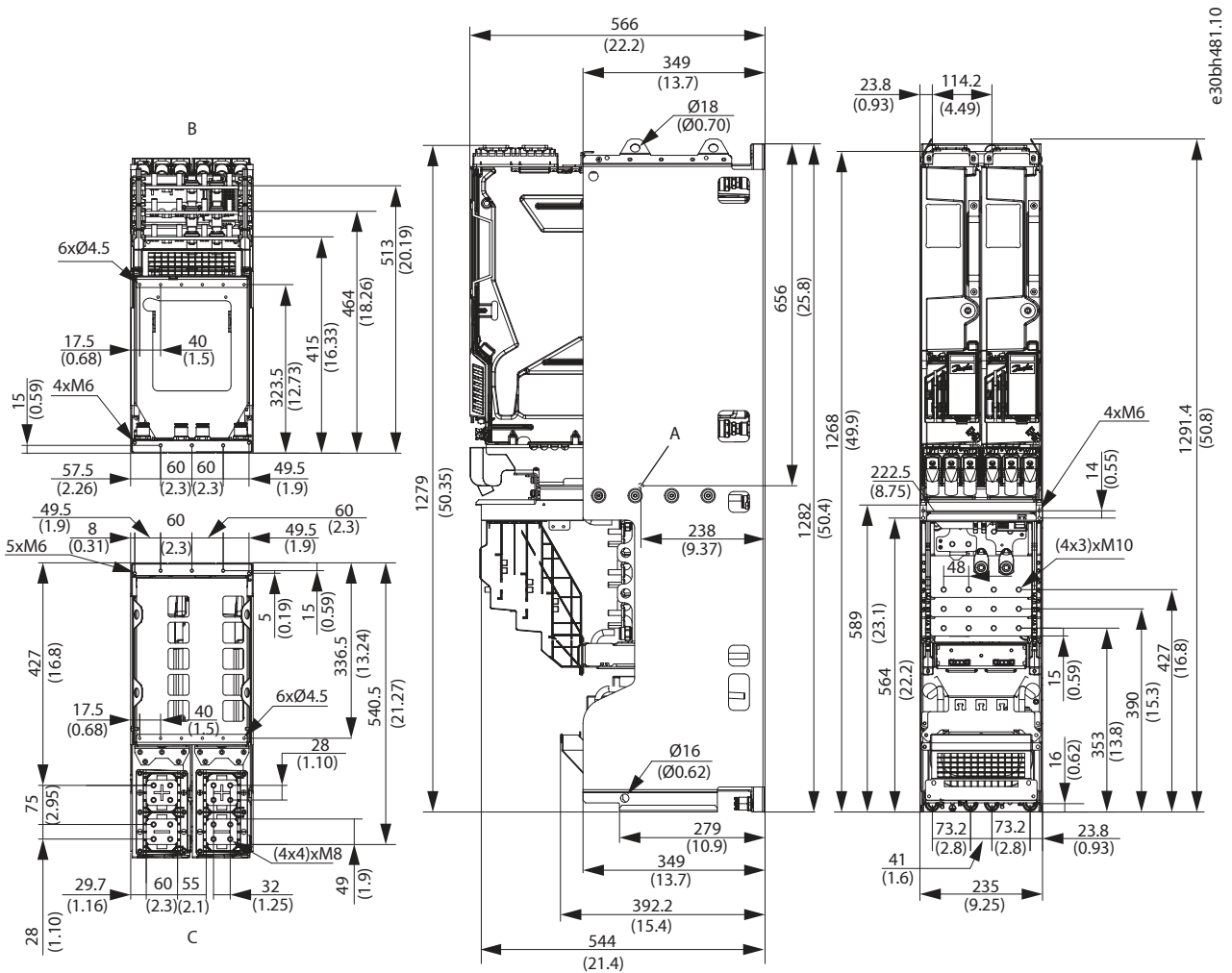

Figure 186: Dimensions of INU, IR12L, in mm (in)

- A Center of gravity
- B View from the top
- C View from the bottom

10.2.9 Dimensions of Active Front-end Module/Grid Converter, AR12L

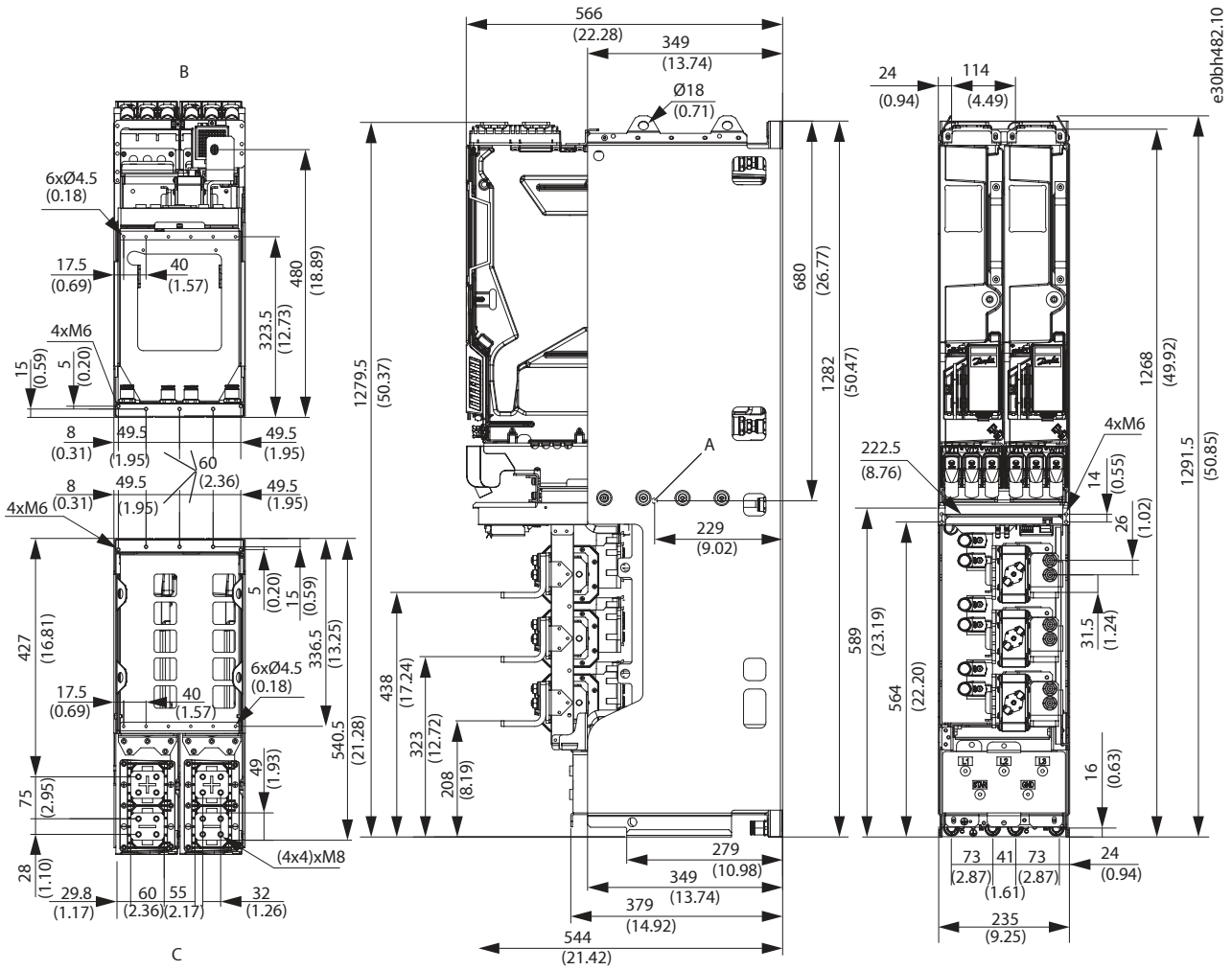

Figure 187: Dimensions of AFE/GC, AR12L, in mm (in)

- A Center of gravity
- B View from the bottom
- C View from the top

10.2.10 Dimensions of the DC/DC Converter, DR12L

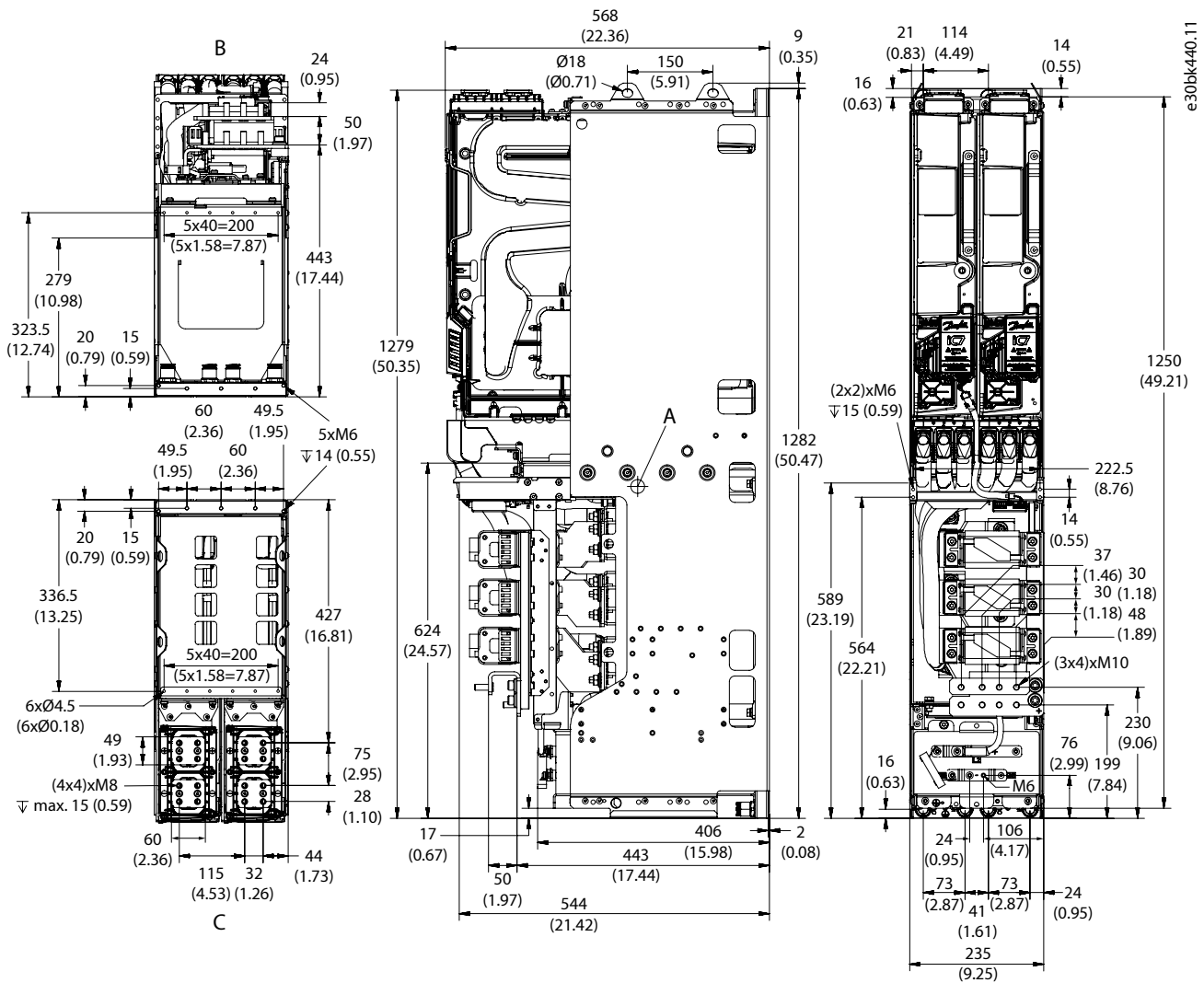

Figure 188: Dimensions of DC/DC Converter, DR12L, in mm (in)

- A Center of gravity
- B View from the bottom
- C View from the top

10.2.11 Dimensions of the LC filter for AM10L

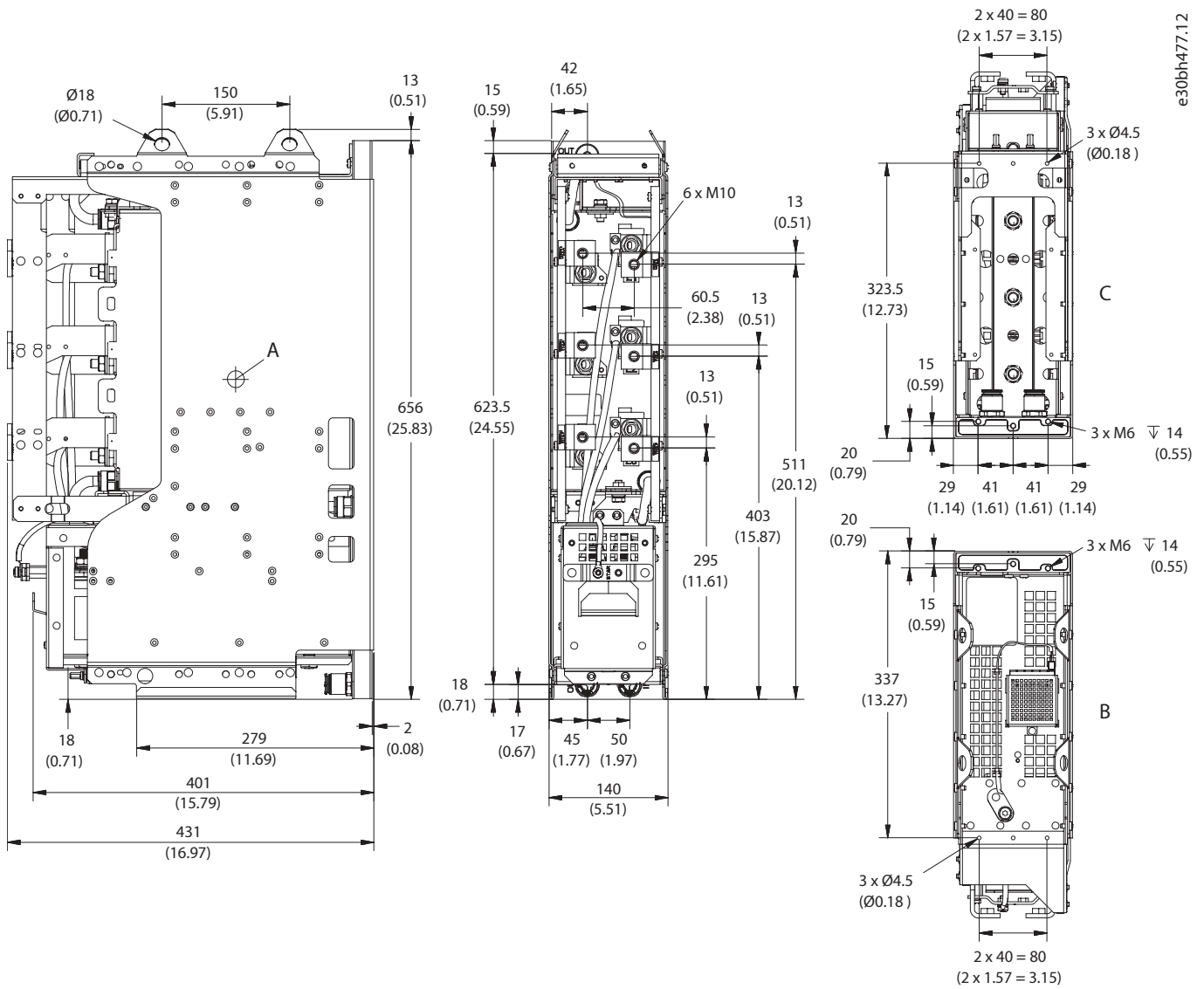

Figure 189: Dimensions of the LC Filter for AM10L, in mm (in)

A Center of gravity

B View from the top

C View from the bottom

10.2.12 Dimensions of the LC Filter for AM12L

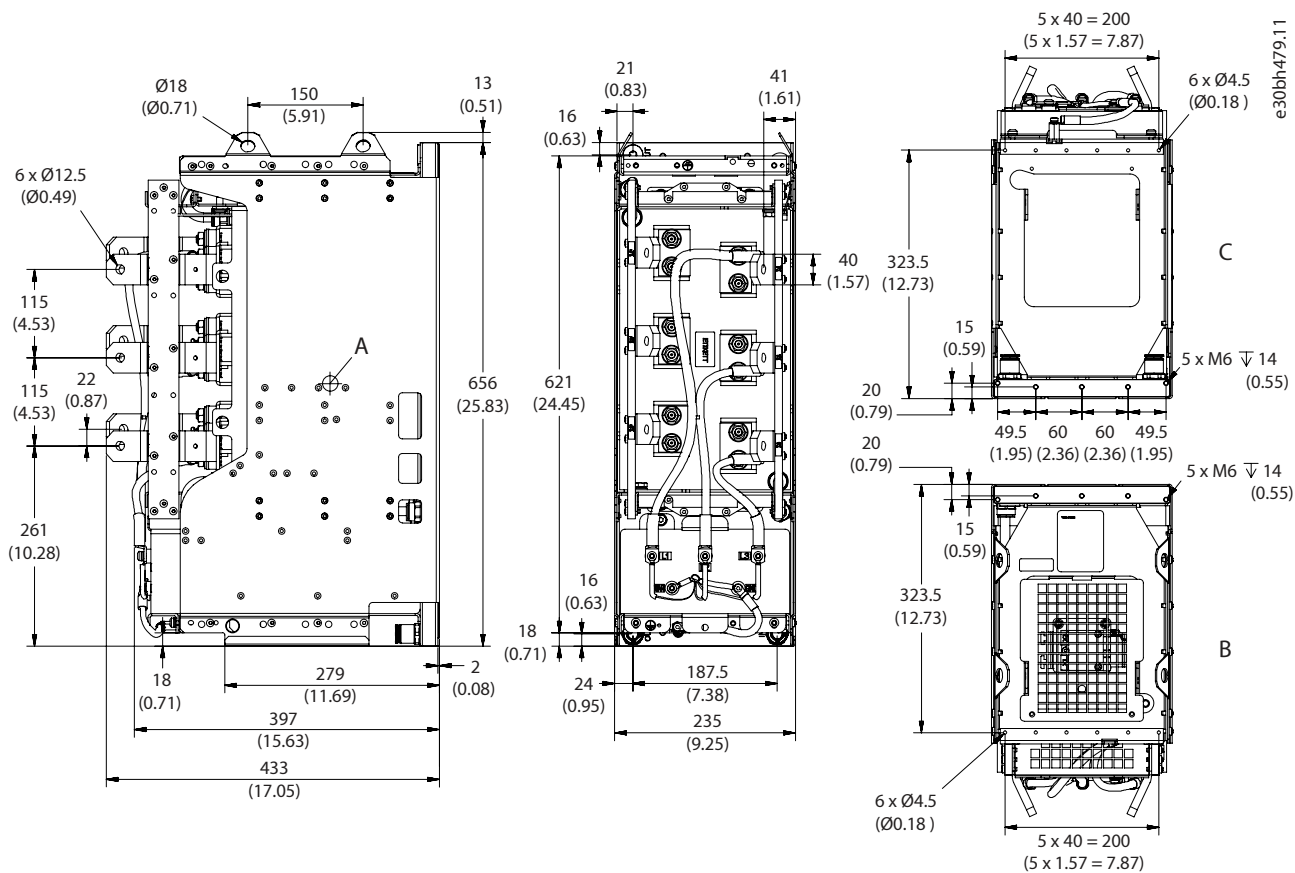
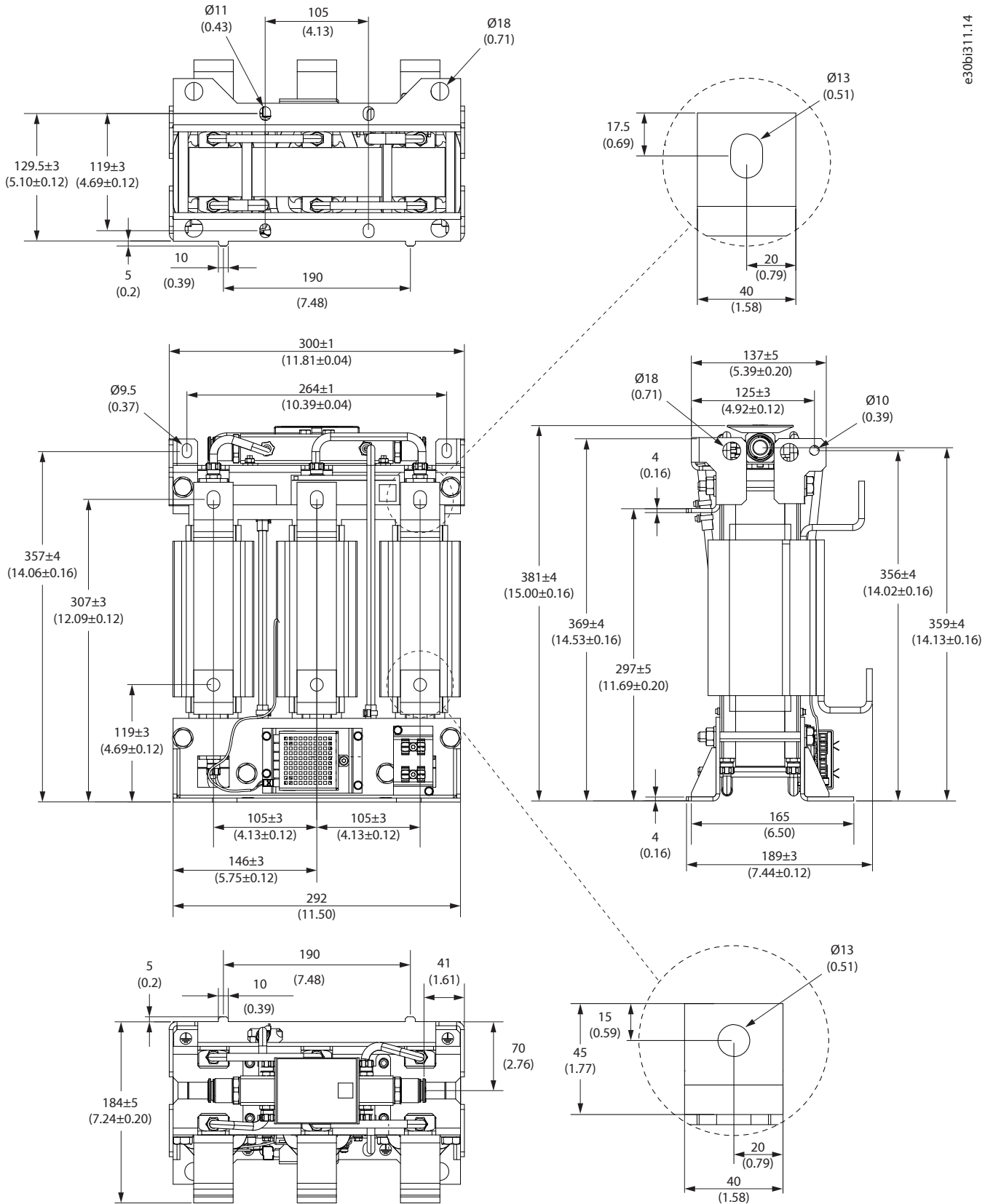

Figure 190: Dimensions of the LC Filter for AM12L, in mm (in)

- A Center of gravity
- B View from the top
- C View from the bottom

10.2.13 Dimensions of the L Filter, 400 A



e30b1311.14

Figure 191: Dimensions of the L Filter, 400 A

10.2.14 Dimensions of the L Filter, 1000 A

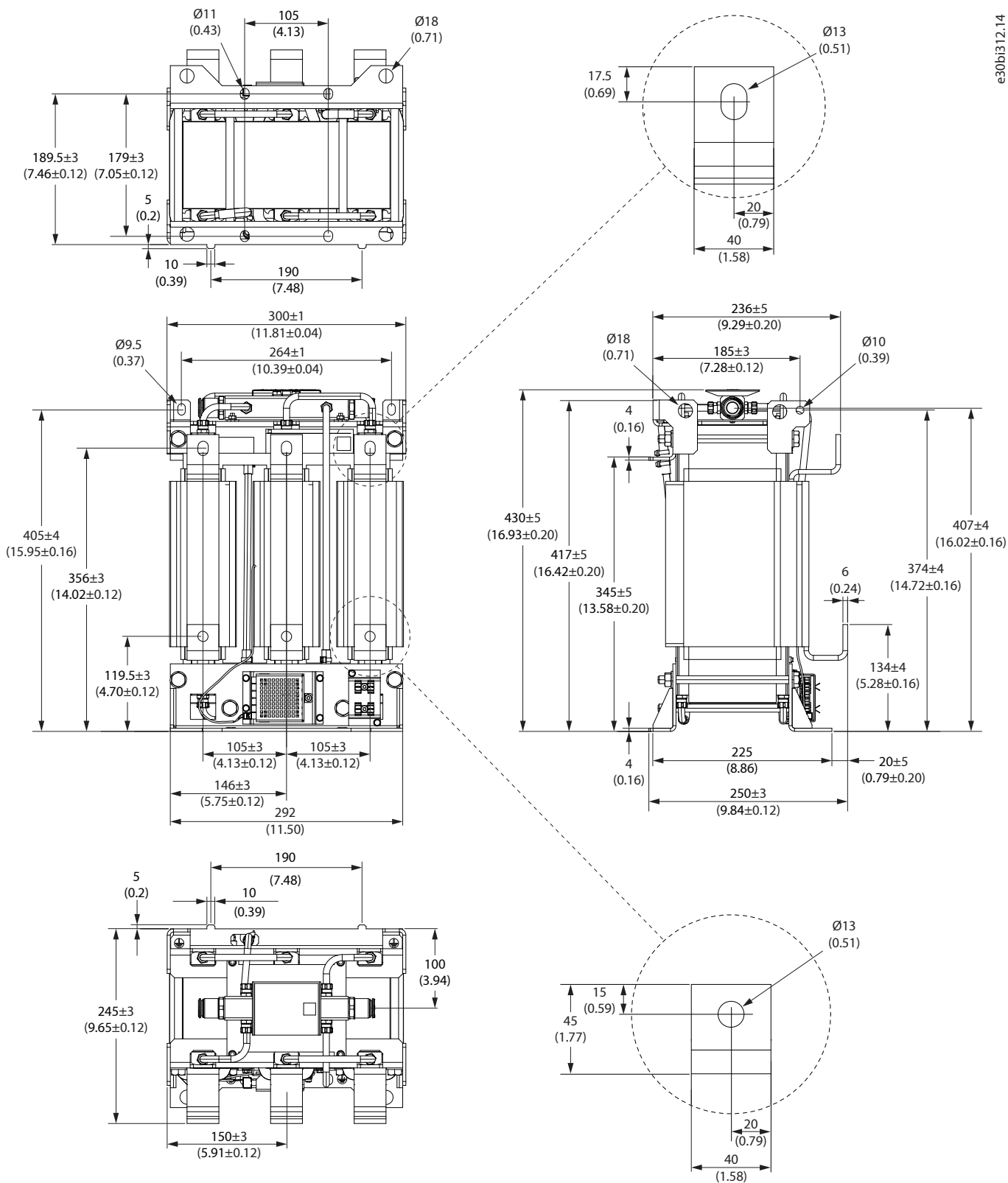

Figure 192: Dimensions of the L Filter, 1000 A

10.2.15 Dimensions of the L Filter, 1640 A

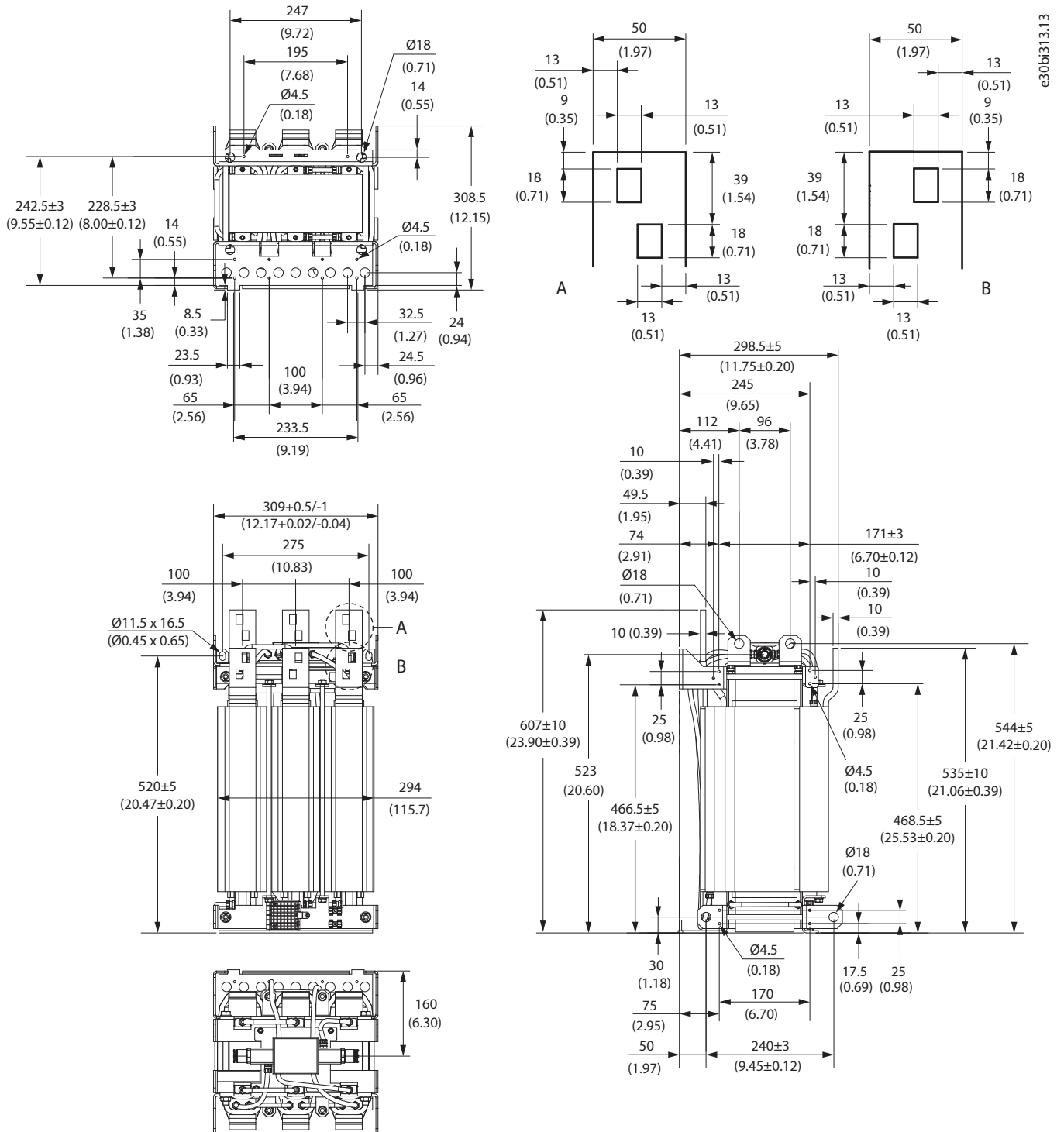
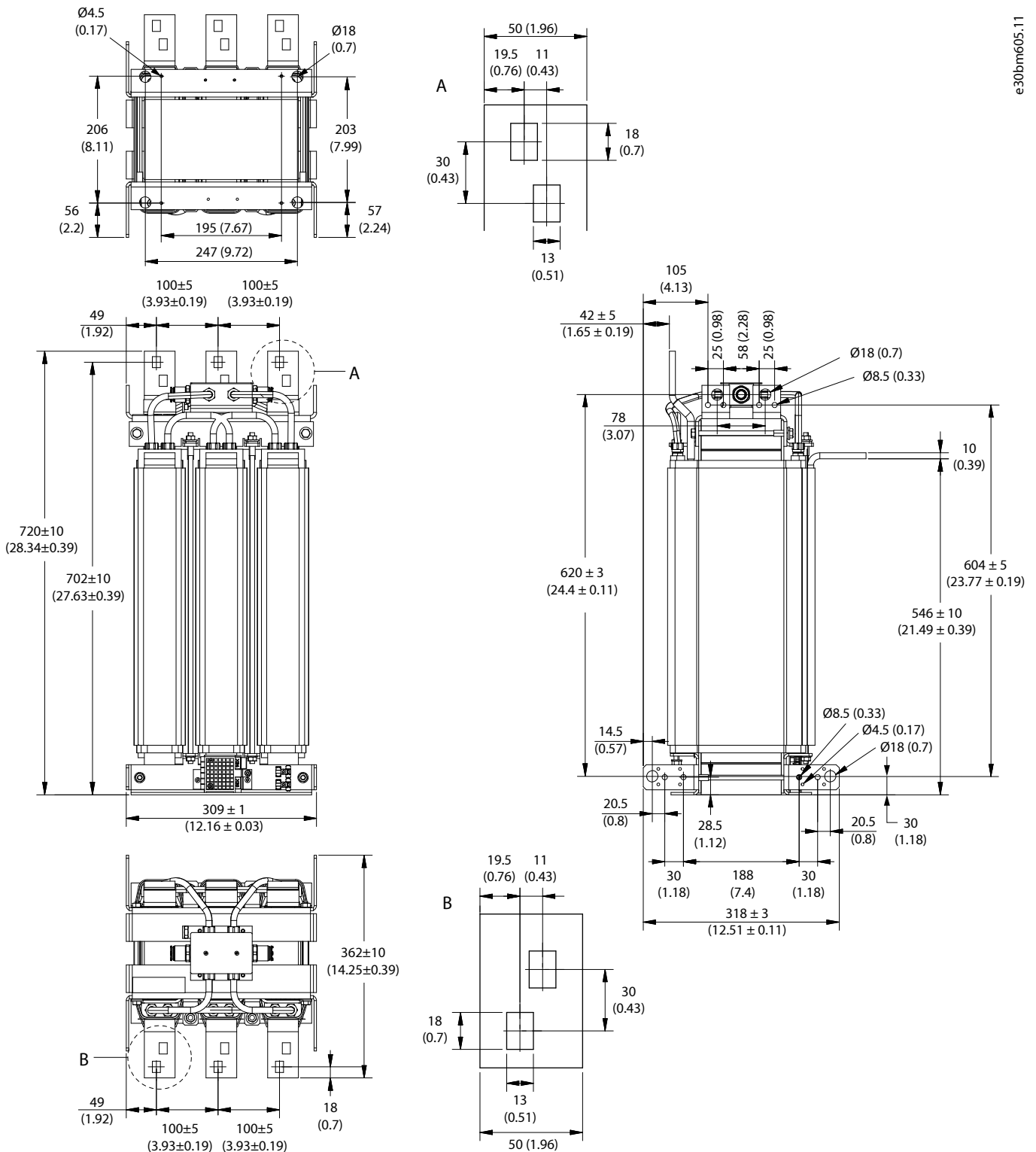

Figure 193: Dimensions of the L Filter, 1640 A

A The connector on top of the filter

B The connector on top of the filter

10.2.16 Dimensions of the L Filter, 2300 A



e30bm605.11

Figure 194: Dimensions of the L Filter, 2300 A

A The connector on top of the filter

B The connector on top of the filter

10.2.17 Dimensions of the Reactor, 450 A

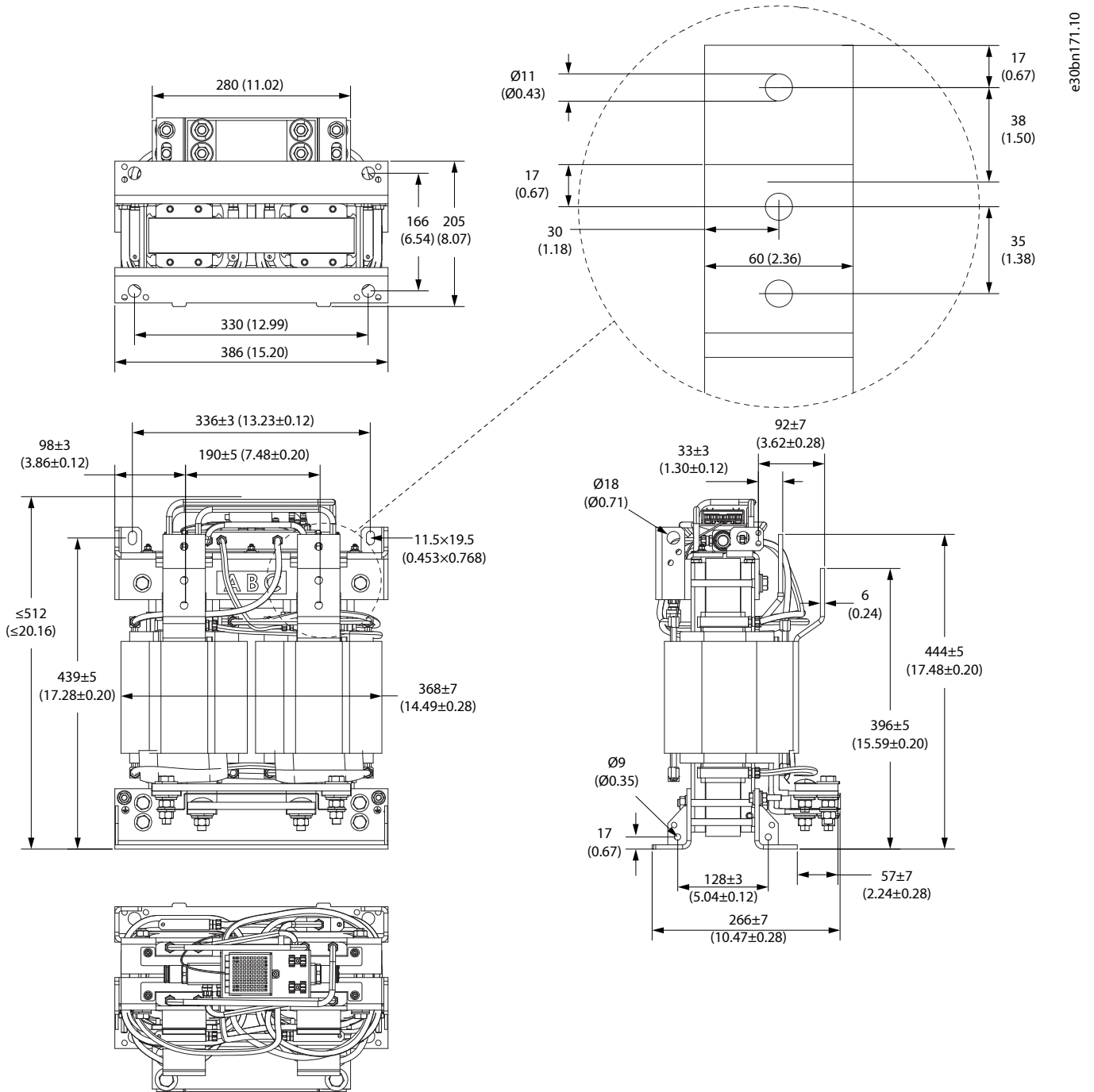

e30bn171.10

Figure 195: Dimensions of the Reactor, 450 A in mm (in)

10.2.18 Dimensions of the Reactor, 900 A

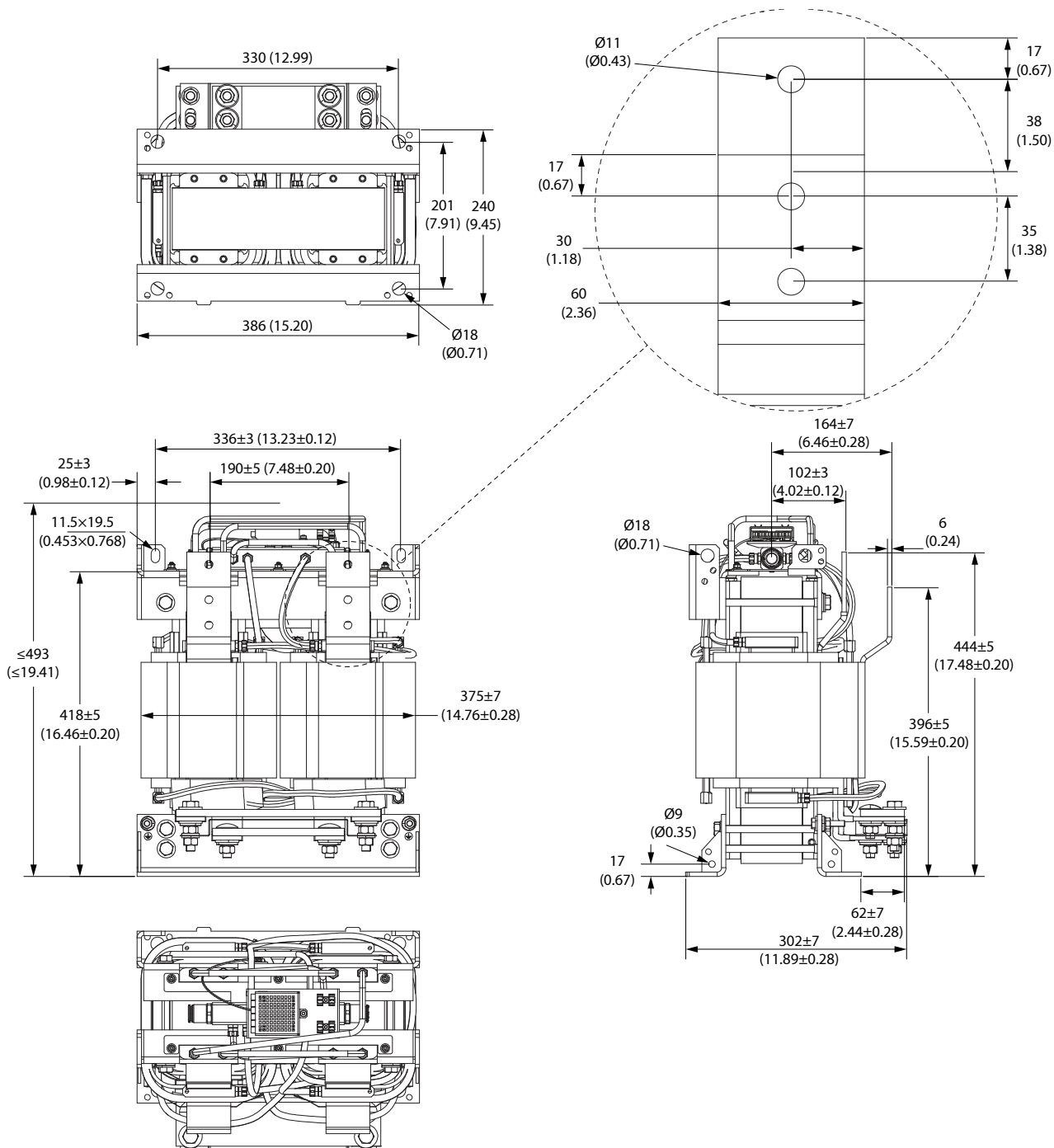

e30bn172.10

Figure 196: Dimensions of the Reactor, 900 A in mm (in)

10.2.19 Dimensions of the Reactor, 1750 A

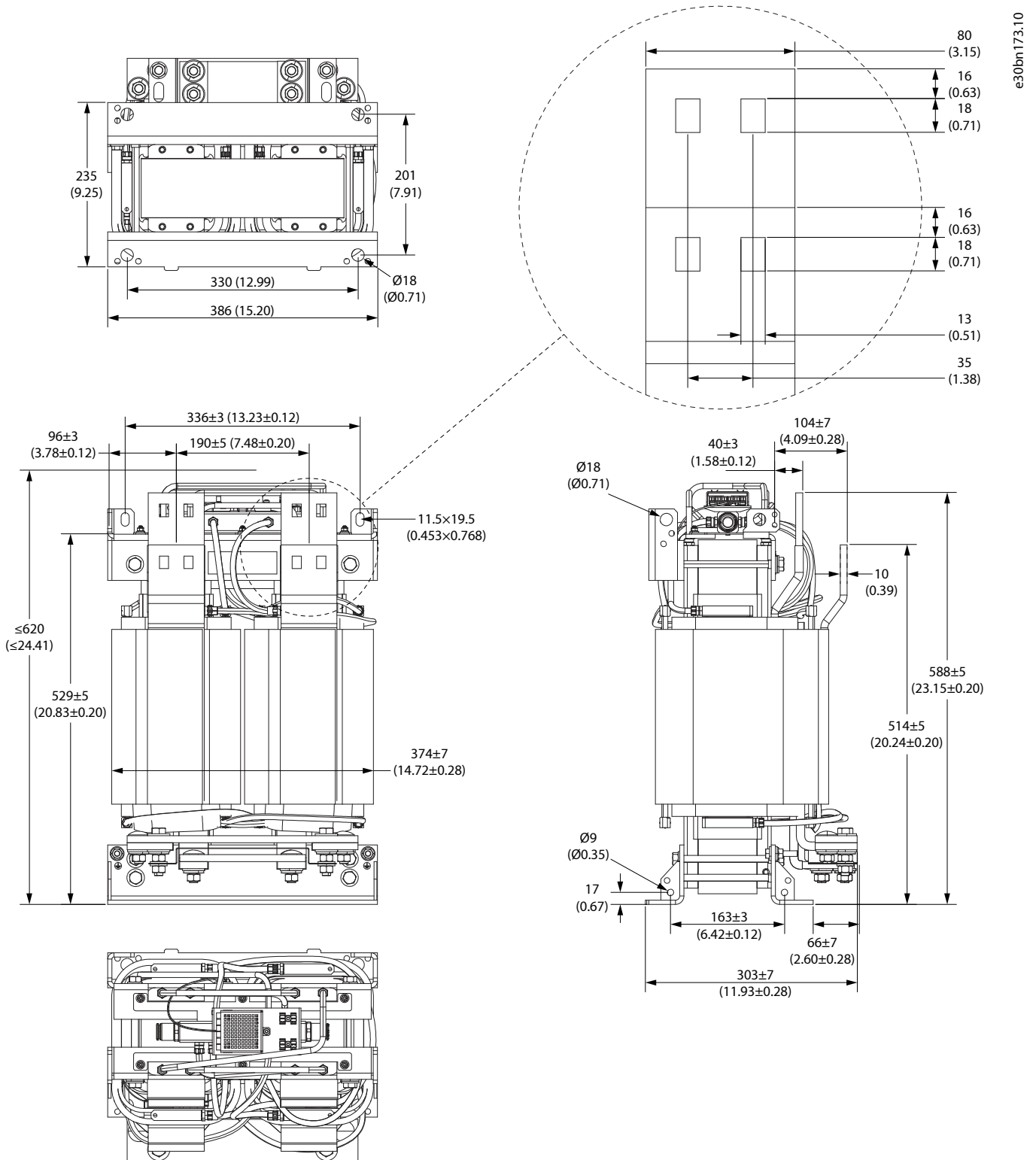

e30bn173.10

Figure 197: Dimensions of the Reactor, 1750 A in mm (in)

10.2.21 Dimensions of the Fuse Holder for Feedback DC Fuses

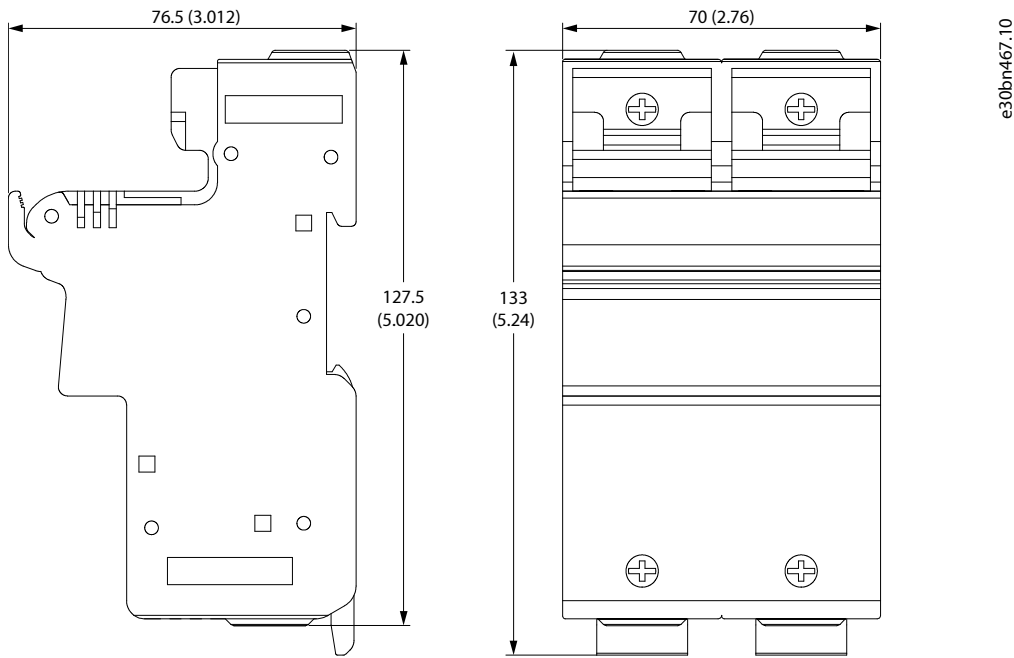

Figure 199: Dimensions of the Fuse Holder for Feedback DC Fuses

10.2.22 Dimensions of the dU/dt Filter and the Common-mode Filter for IM10L

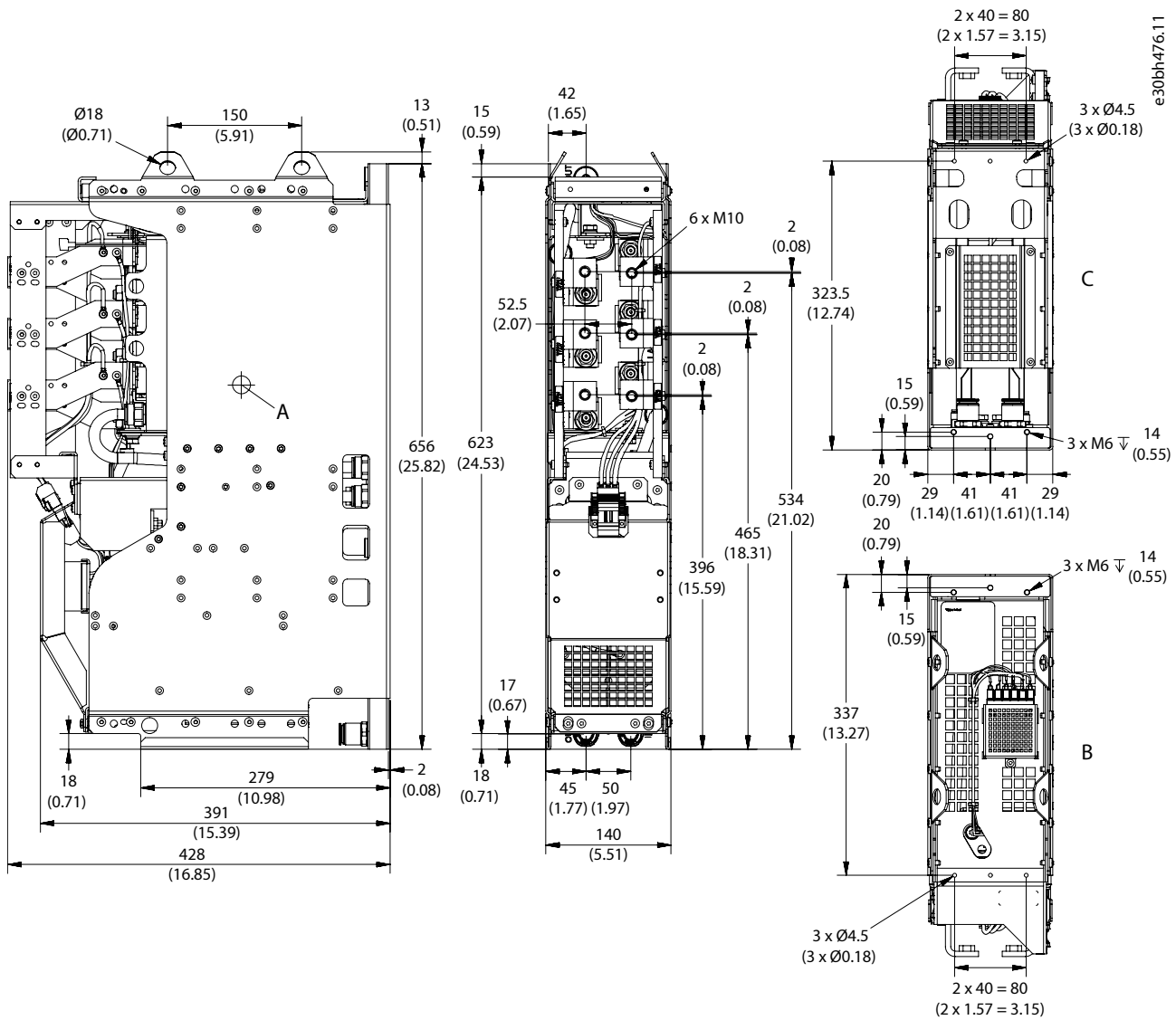

Figure 200: Dimensions of the dU/dt Filter and Common-mode Filter for IM10L, in mm (in)

- | | | | |
|---|----------------------|---|-------------------|
| A | Center of gravity | B | View from the top |
| C | View from the bottom | | |

10.2.23 Dimensions of the dU/dt Filter for IM12L

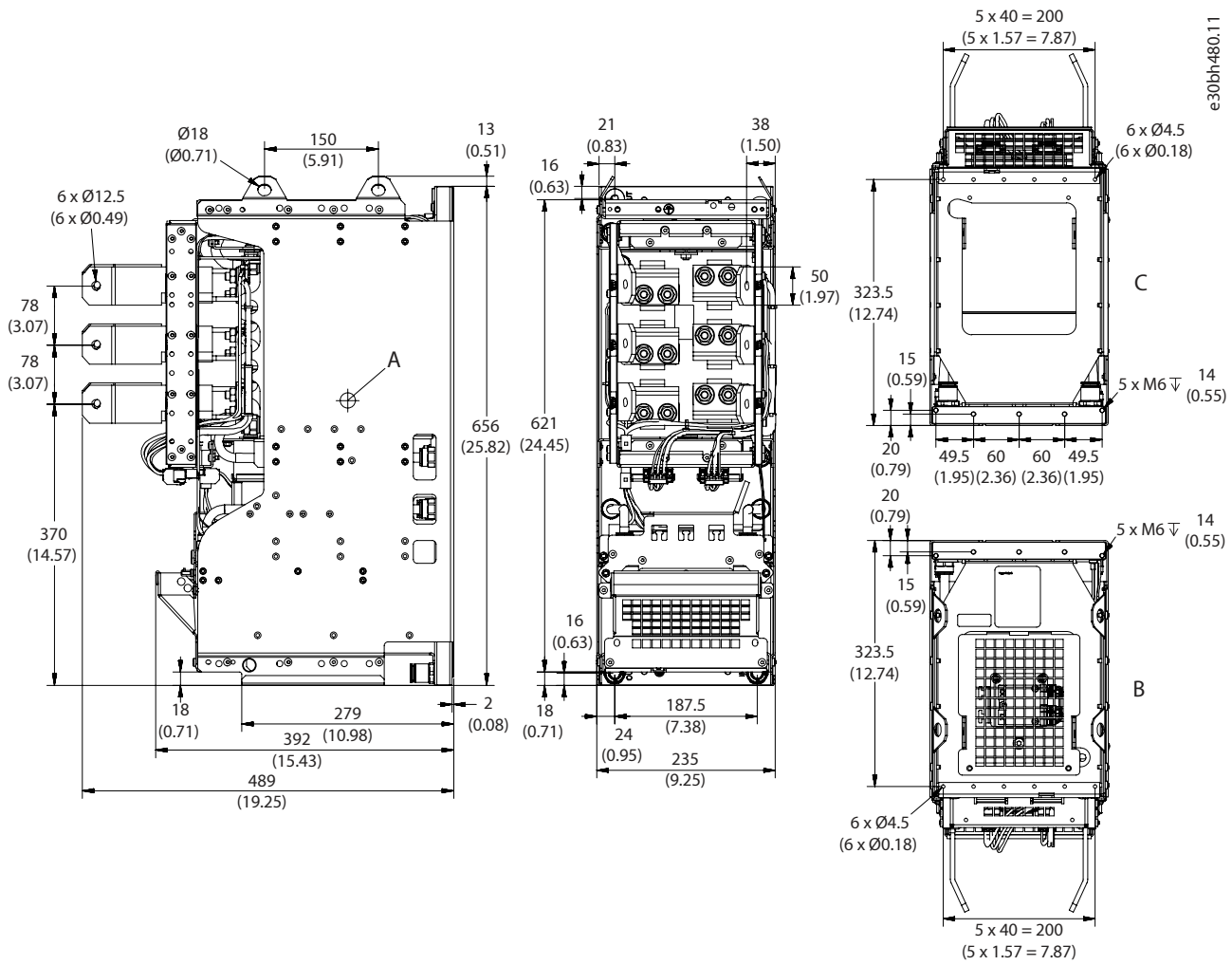

Figure 201: Dimensions of the dU/dt Filter for IM12L, in mm (in)

A	Center of gravity	B	View from the top
C	View from the bottom		

10.2.24 Dimensions of the DC Filter for DM10L

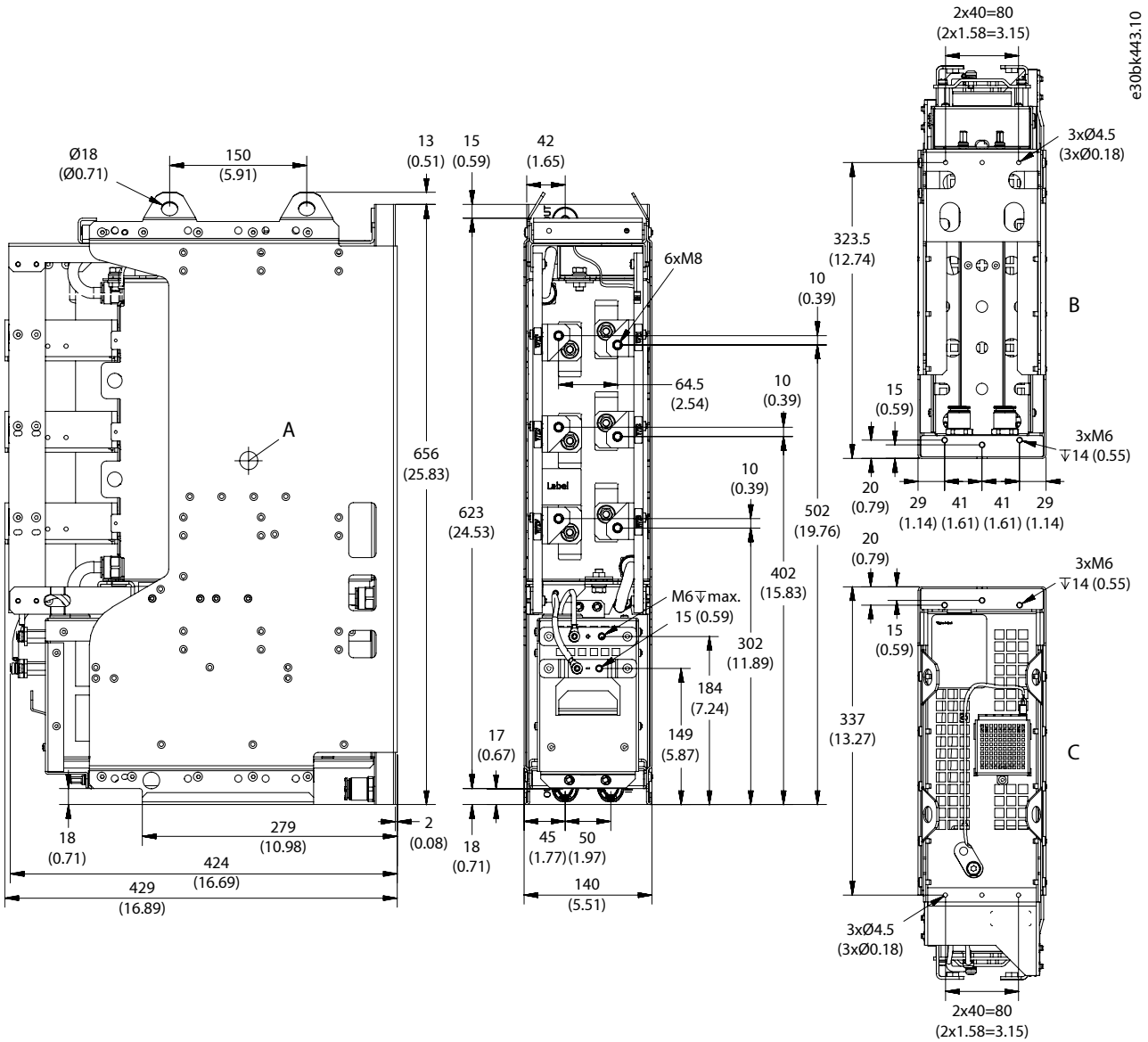

Figure 202: Dimensions of the DC Filter for DM10L in mm (in)

- | | | | |
|---|-------------------|---|----------------------|
| A | Center of gravity | B | View from the bottom |
| C | View from the top | | |

10.2.25 Dimensions of the DC Filter for DM12L

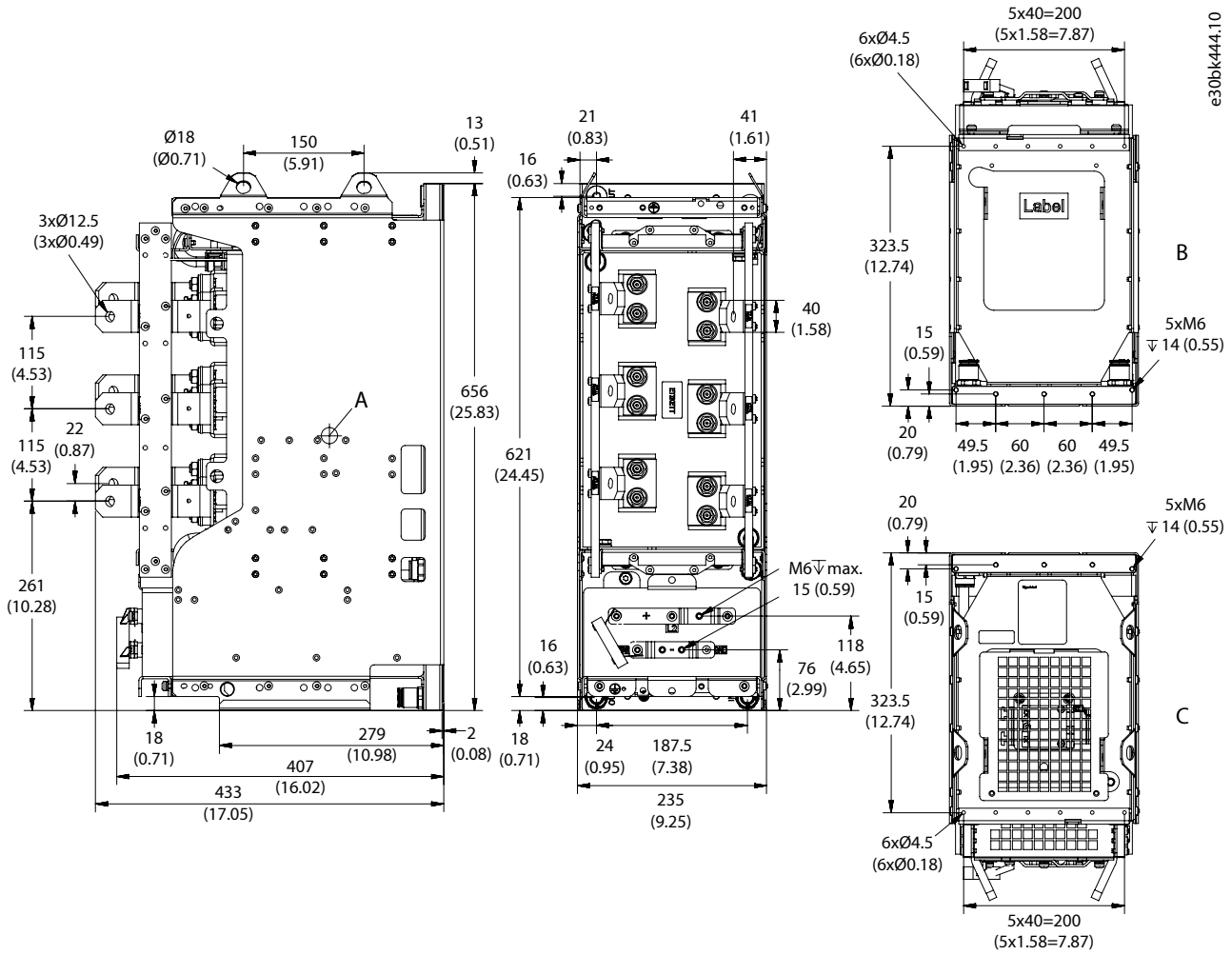

Figure 203: Dimensions of the DC Filter for DM12L in mm (in)

- A Center of gravity
- C View from the top

- B View from the bottom

10.2.26 Dimensions of the Sine-wave Filter

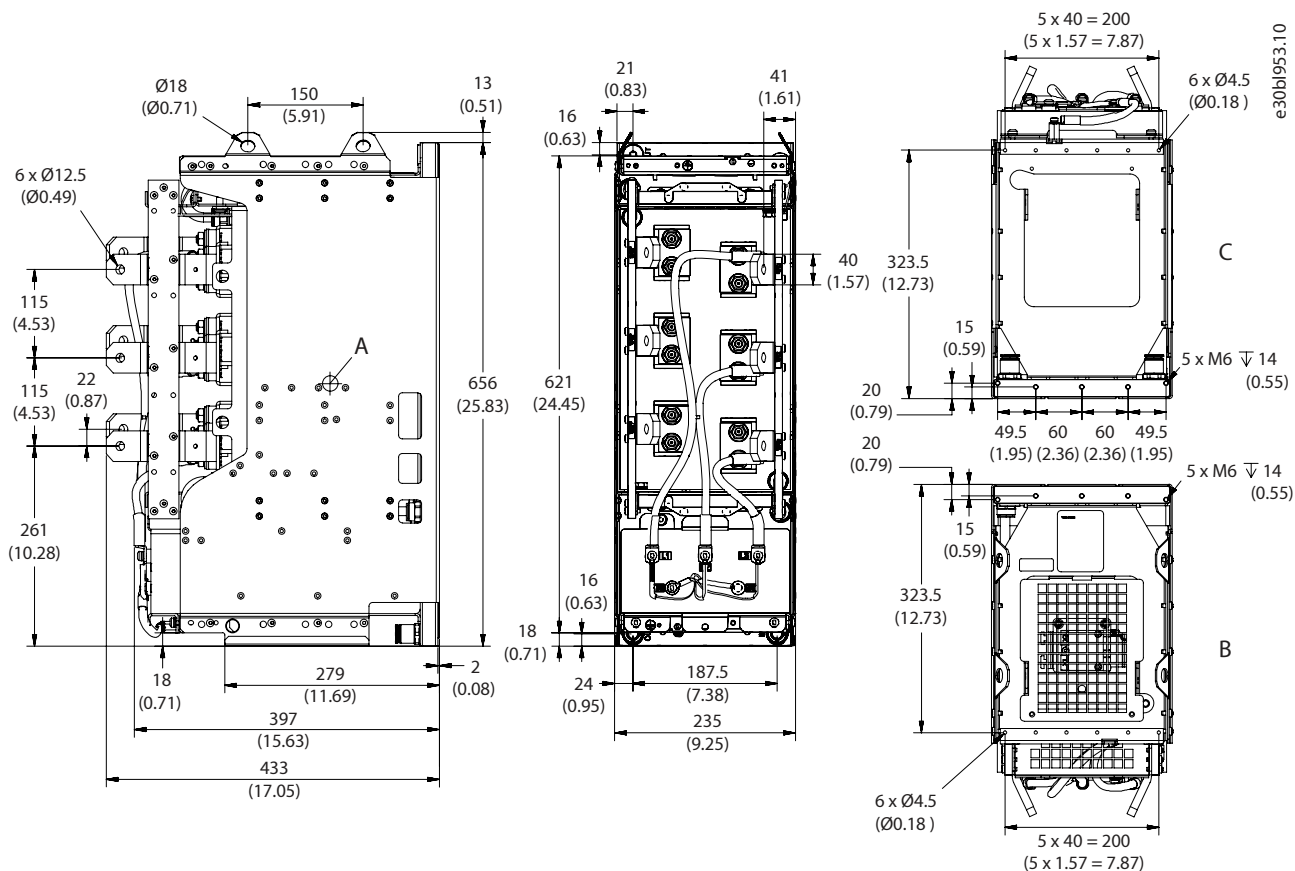

Figure 204: Dimensions of the Sine-wave Filter, in mm (in)

- A Center of gravity
- B View from the top
- C View from the bottom

10.2.27 Dimensions of the Control Unit

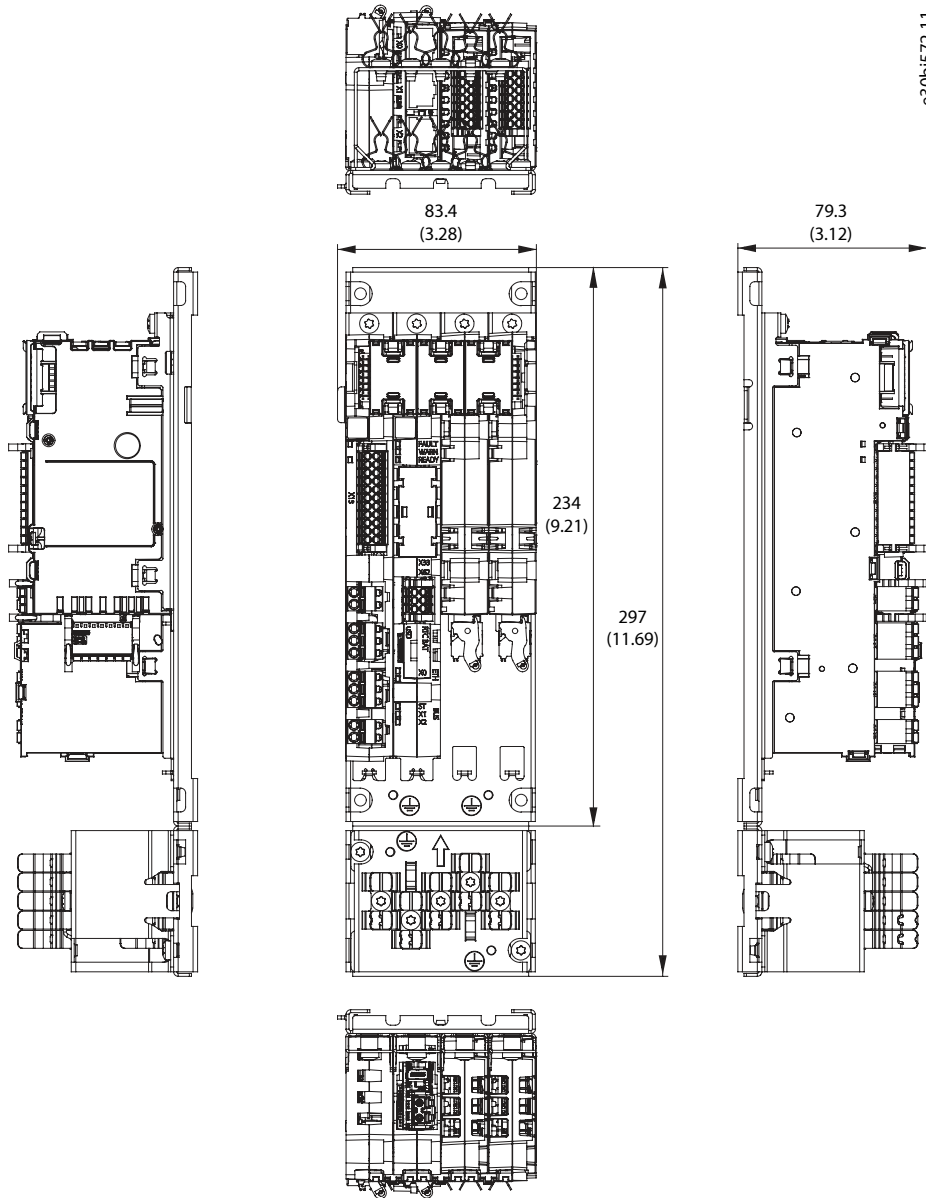

Figure 205: Dimensions of the Control Unit in mm (in), Example Configuration

10.2.28 Dimensions of the Control Unit Mounting Plate

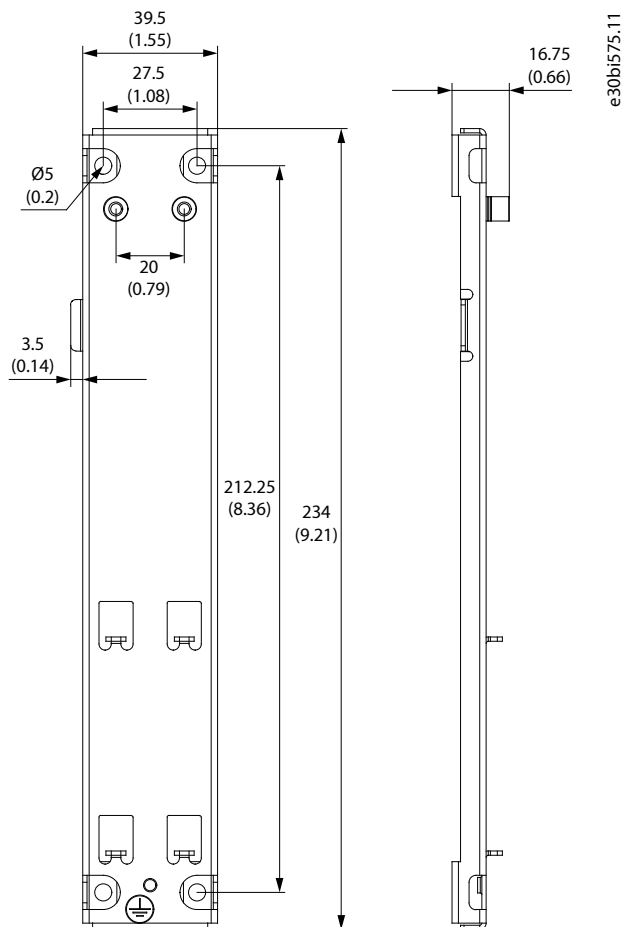
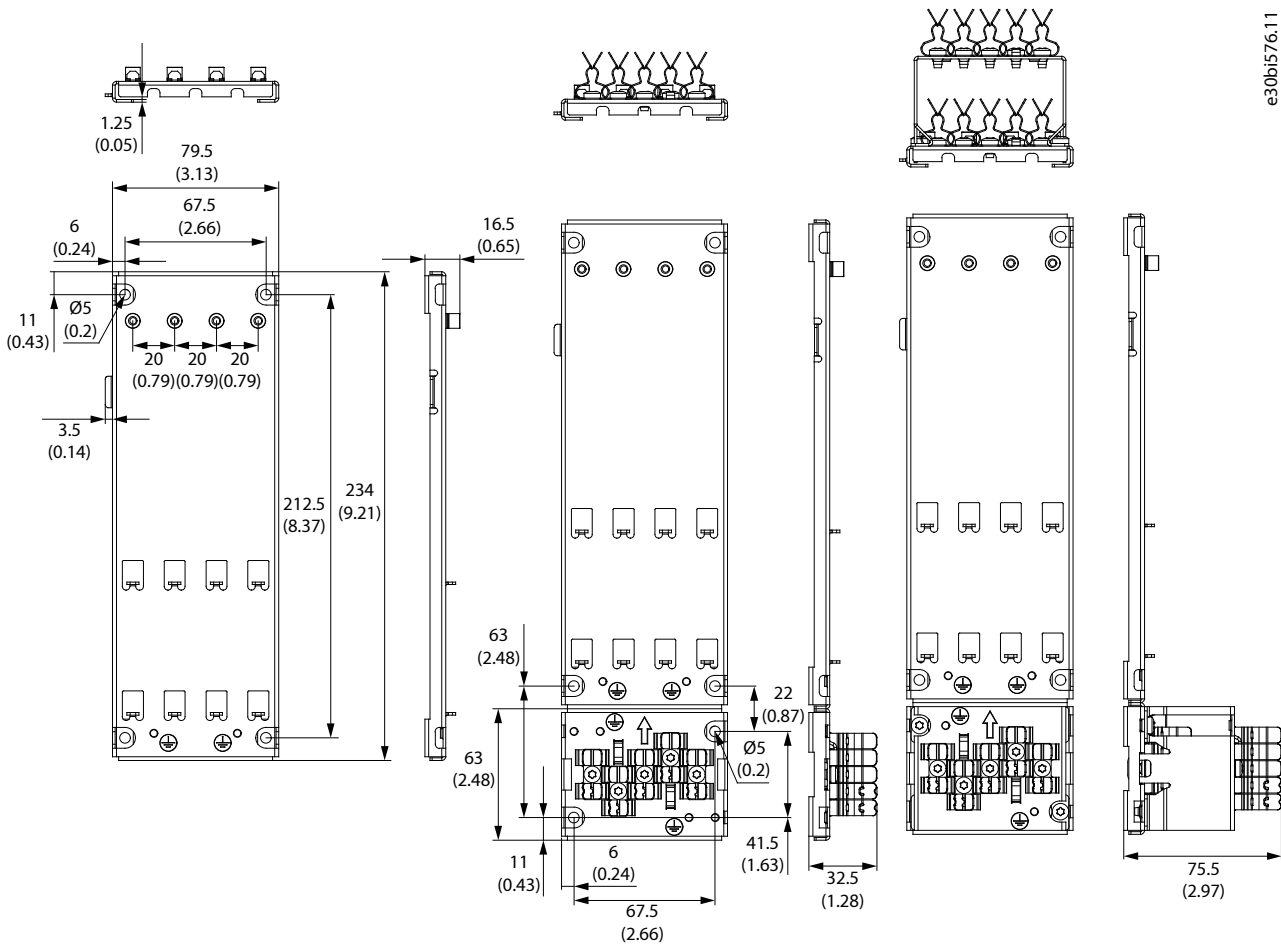

Figure 206: Dimensions of the Modular Control Unit Mounting Plate in mm (in), 2 Places



e30b1576.11

Figure 207: Dimensions of the Modular Control Unit Mounting Plate in mm (in), 4 Places

10.2.29 Dimensions of the Option Connector

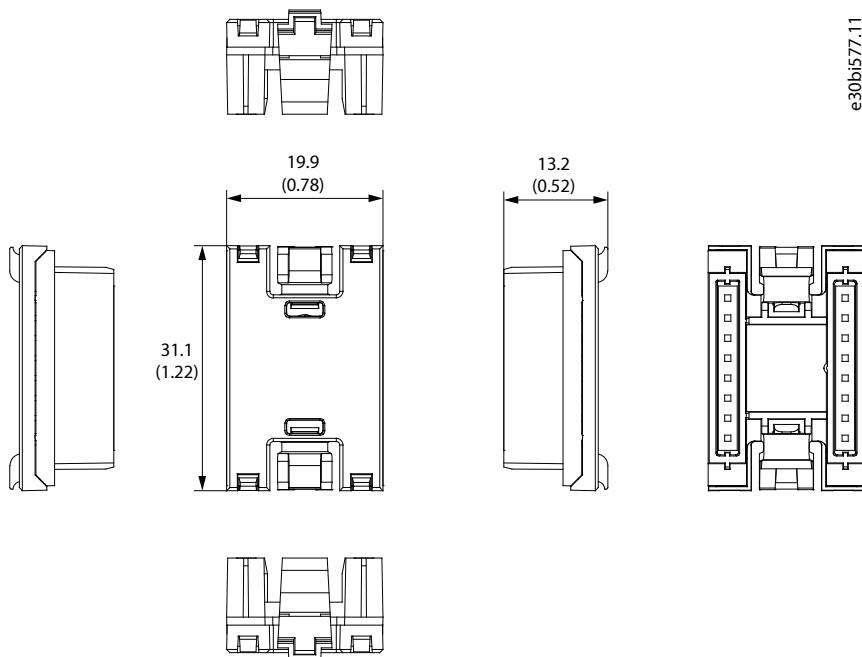

e30b1577.11

Figure 208: Dimensions of the Option Connector in mm (in)

10.2.30 Dimensions of the Control Board

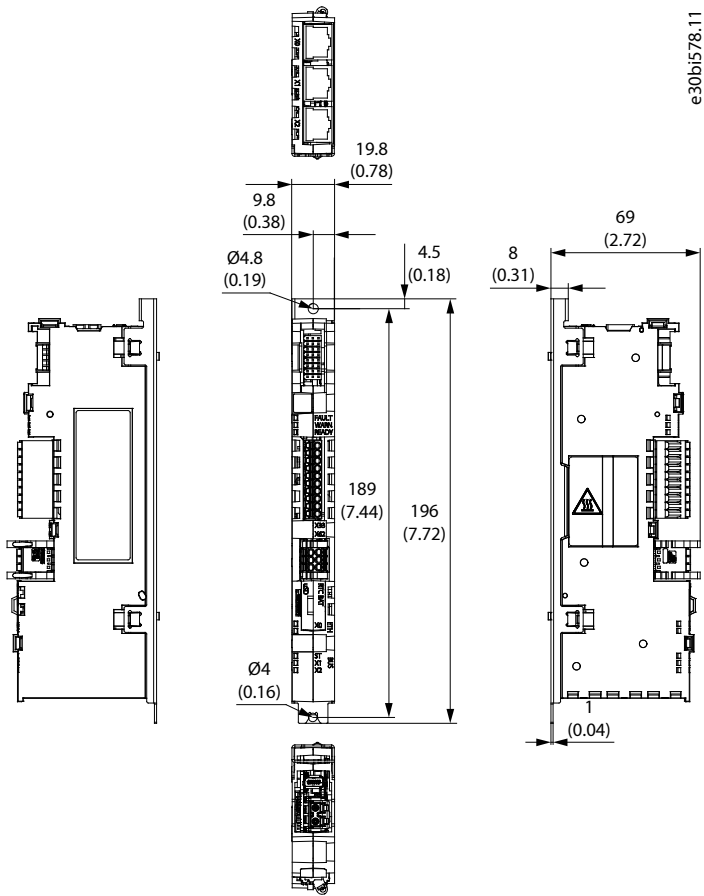

Figure 209: Dimensions of the Control Board in mm (in)

10.2.31 Dimensions of the I/O and Relay Option

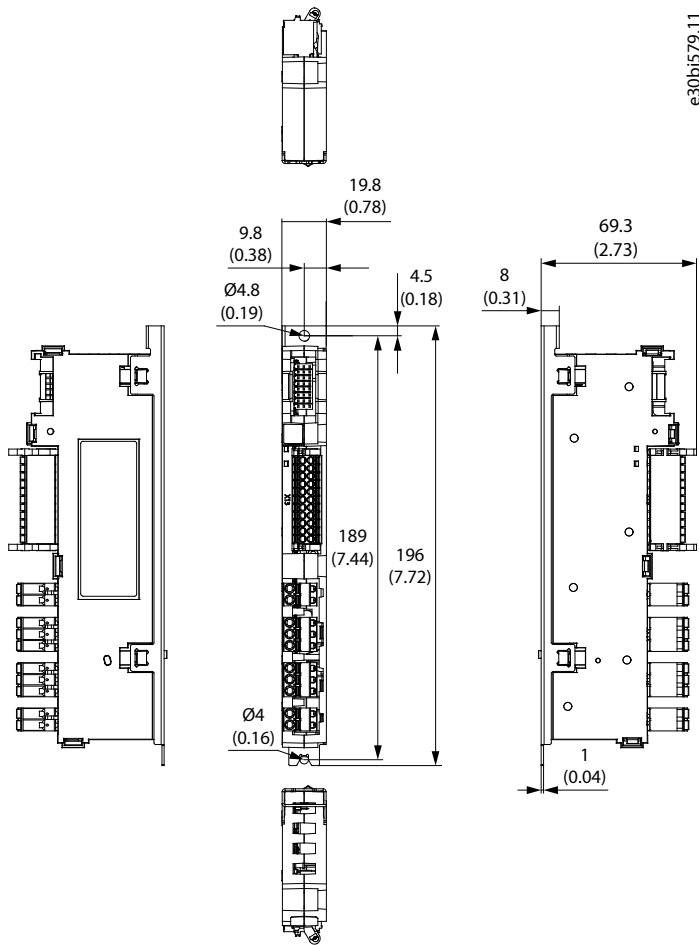

Figure 210: Dimensions of the I/O and Relay Option in mm (in)

10.2.32 Dimensions of an Option Board

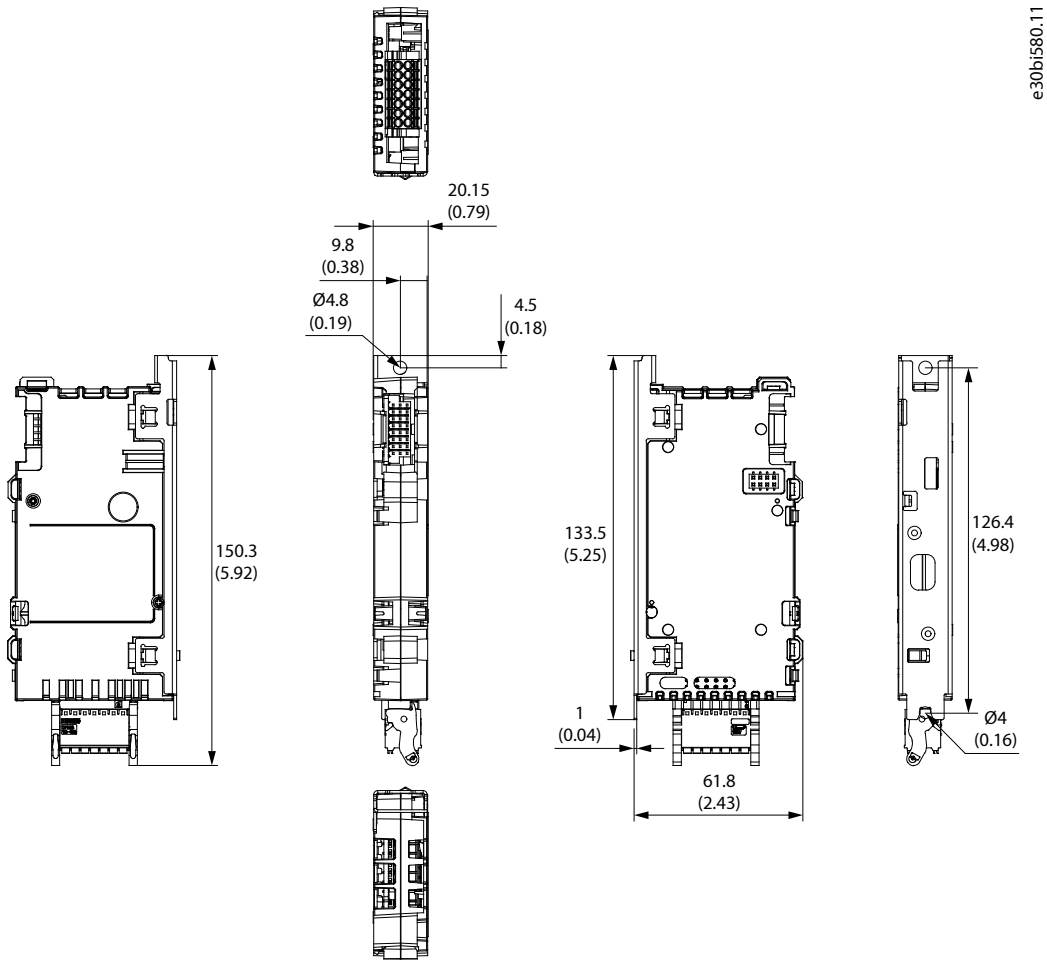
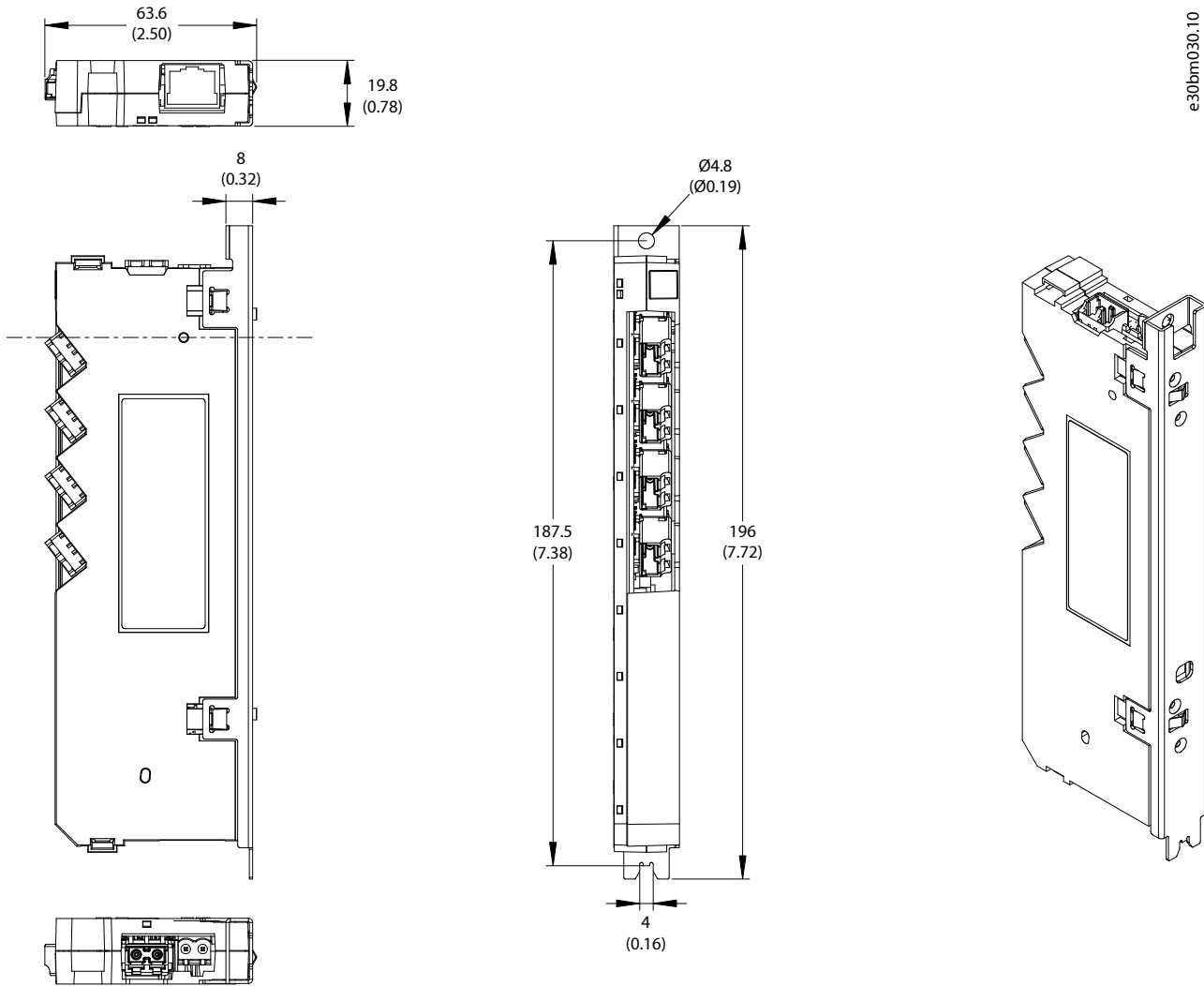

Figure 211: Dimensions of an Option Board in mm (in)

10.2.33 Dimensions of the 4-port Star Coupler Board



e30bm030.10

Figure 212: Dimensions of the 4-port Star Coupler Board in mm (in)

10.2.34 Dimensions of the 8-port Star Coupler Board

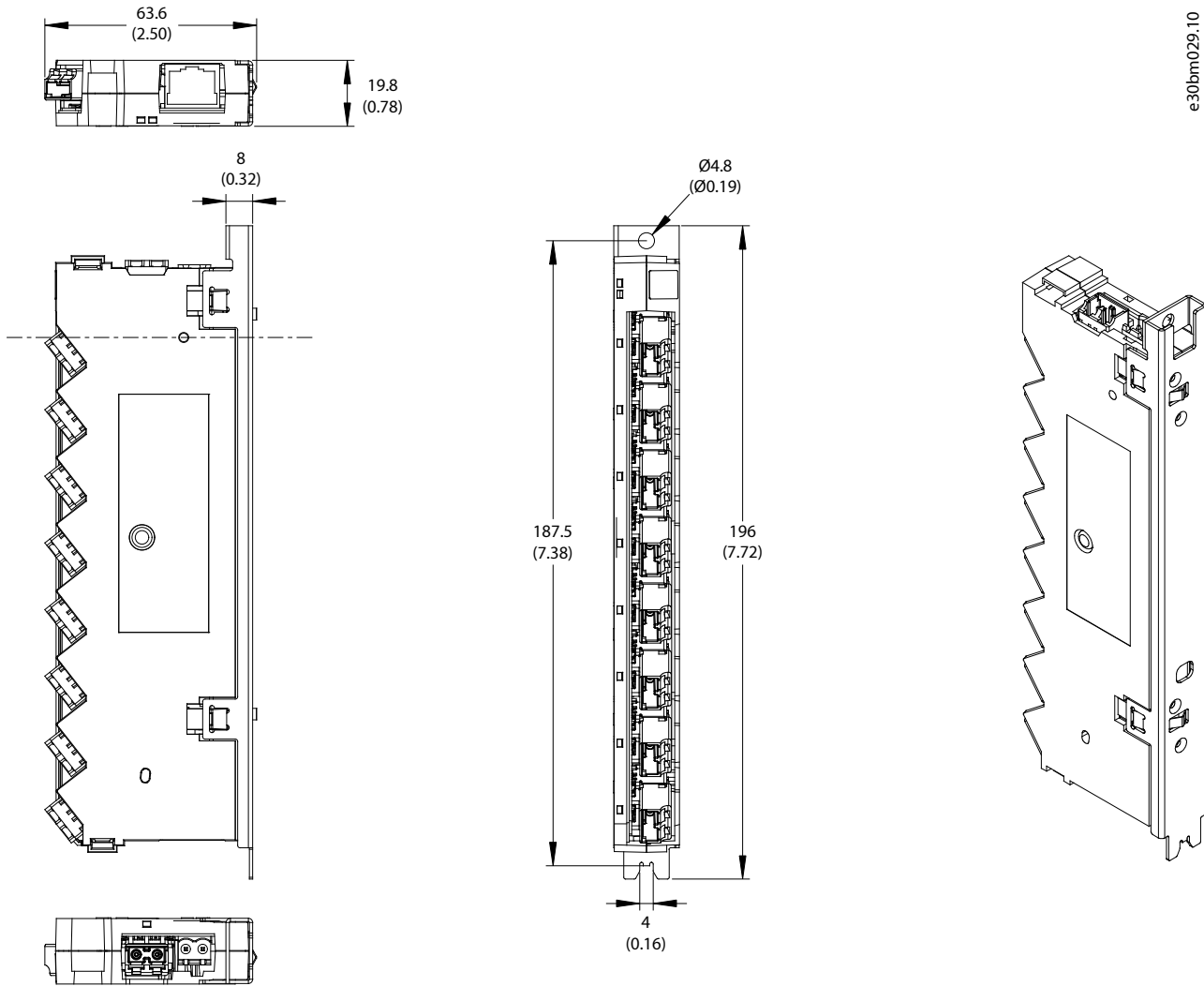

e30bm029.10

Figure 213: Dimensions of the 8-port Star Coupler Board in mm (in)

10.2.35 Dimensions of the 16-port Star Coupler Board

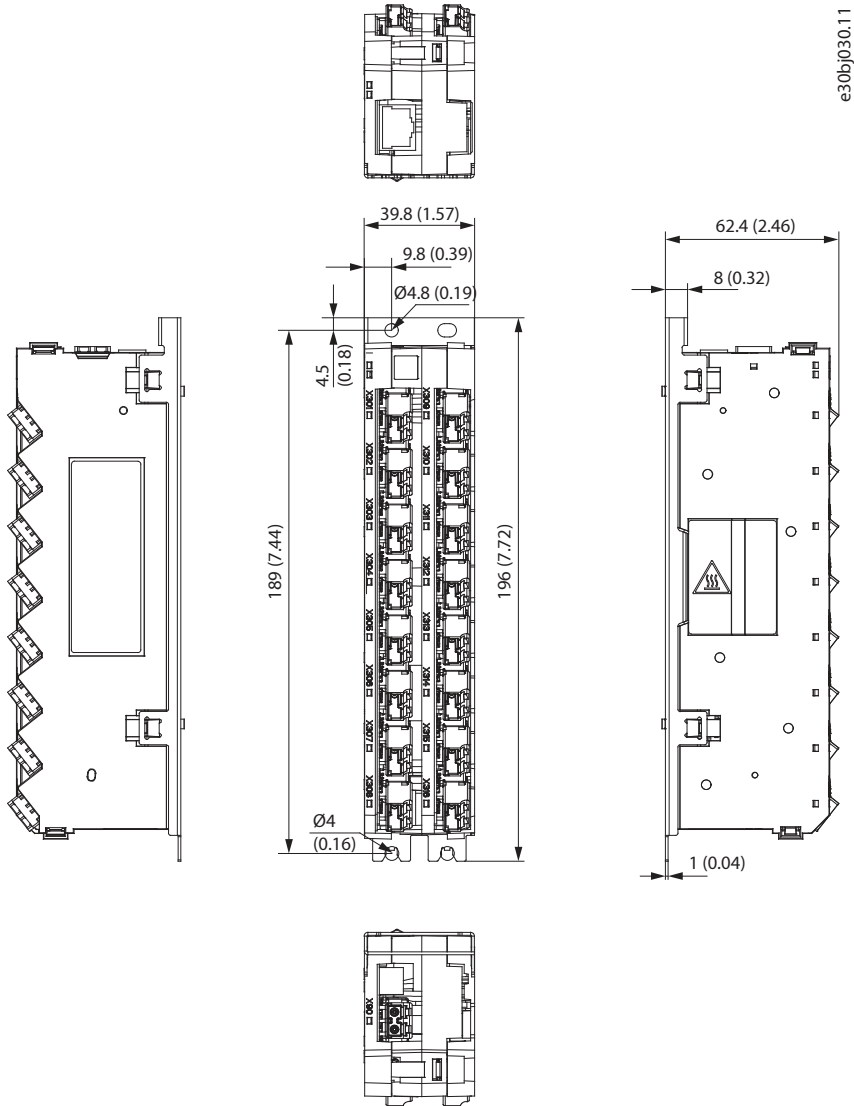

Figure 214: Dimensions of the 16-port Star Coupler Board in mm (in)

10.2.36 Dimensions of the Pre-charging Unit, IEC

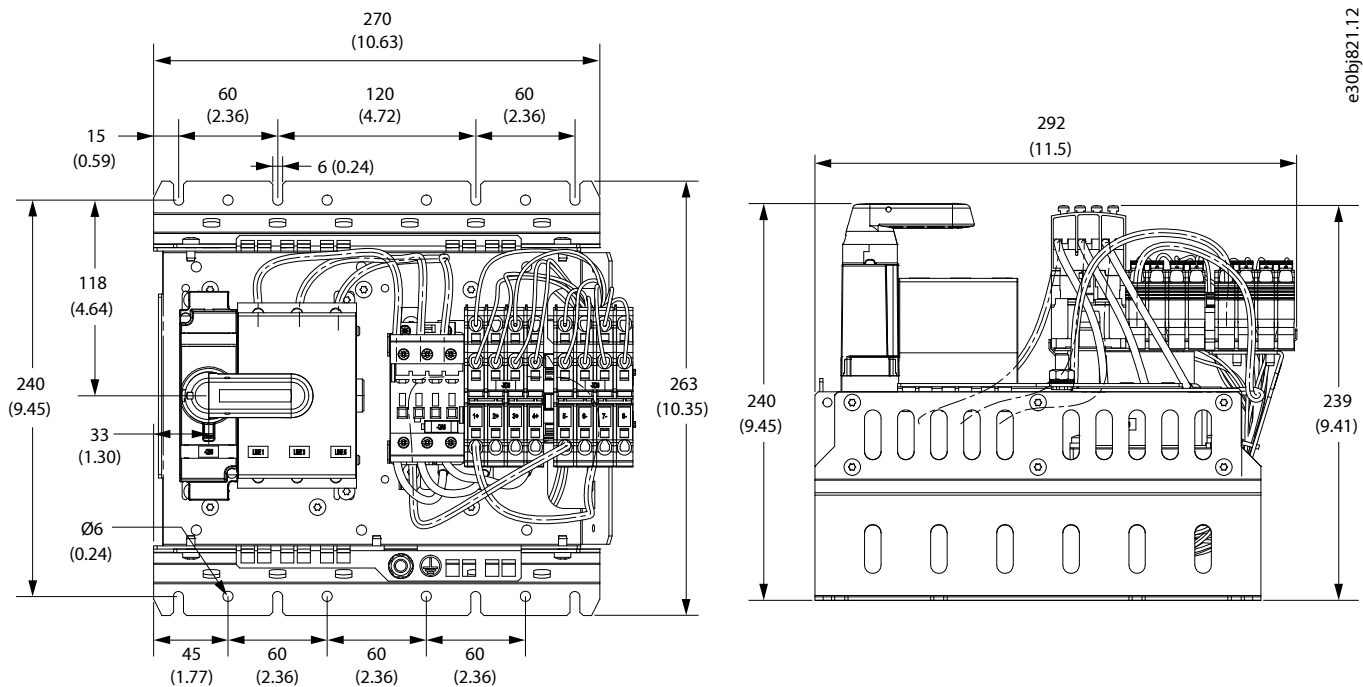

Figure 215: Dimensions of the Pre-charging Unit in mm (in), IEC

e30bj821.12

10.2.37 Dimensions of the Pre-charging Unit, UL

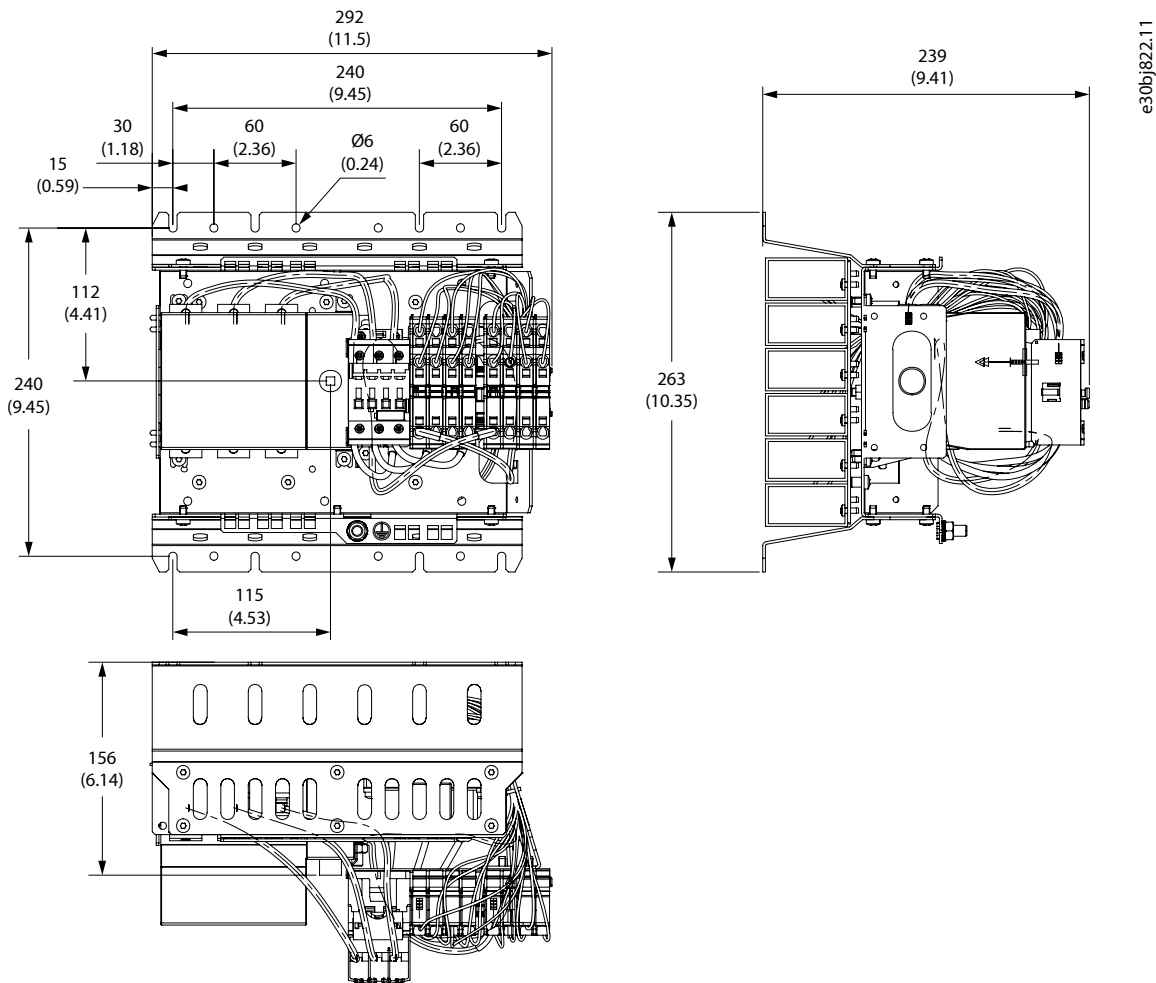

Figure 216: Dimensions of the Pre-charging Unit in mm (in), UL

10.2.38 Dimensions of the DC Fuses, xx10L

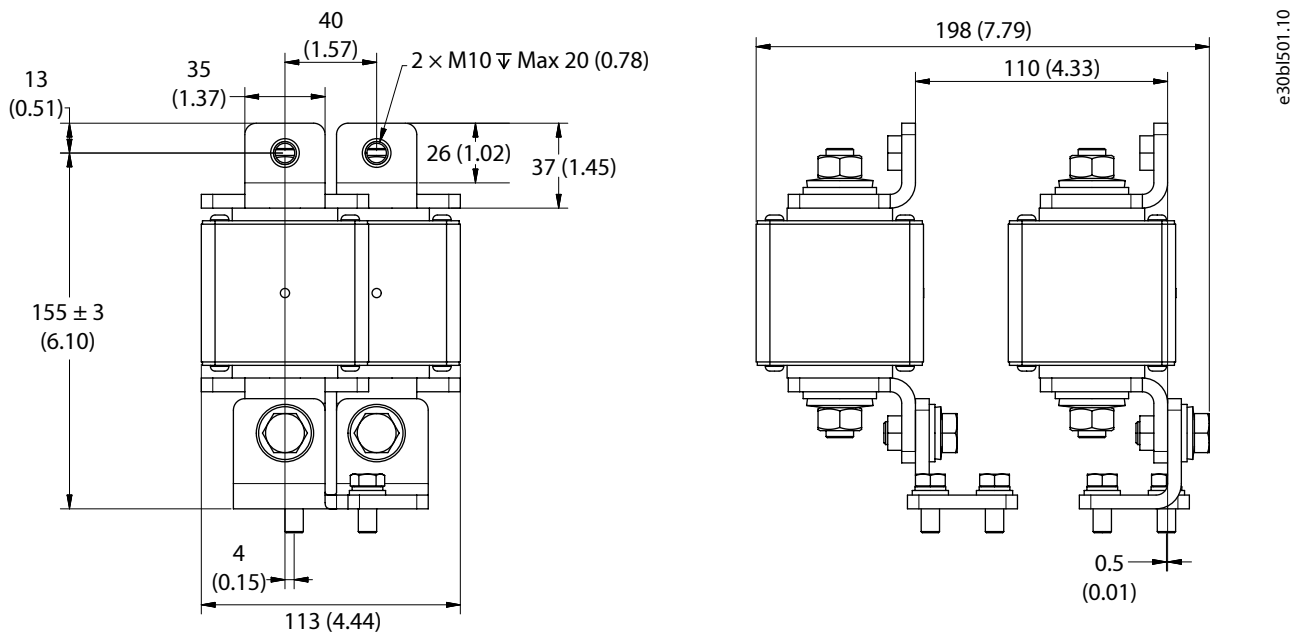

Figure 217: Dimensions of the DC Fuses, AR10L, IR10L, DR10L, AM10L, IM10L, DM10L, in mm (in)

10.2.39 Dimensions of the DC Fuses, xx12L

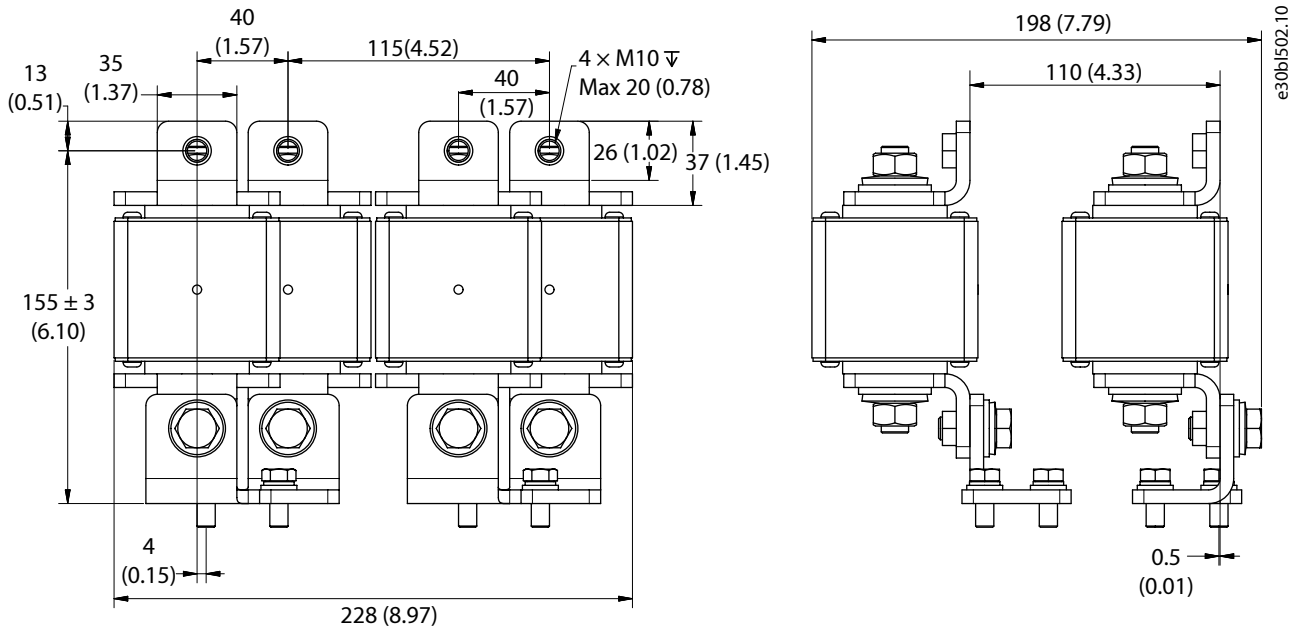

Figure 218: Dimensions of the DC Fuses, AR12L, IR12L, DR12L, AM12L, IM12L, DM12L, in mm (in)

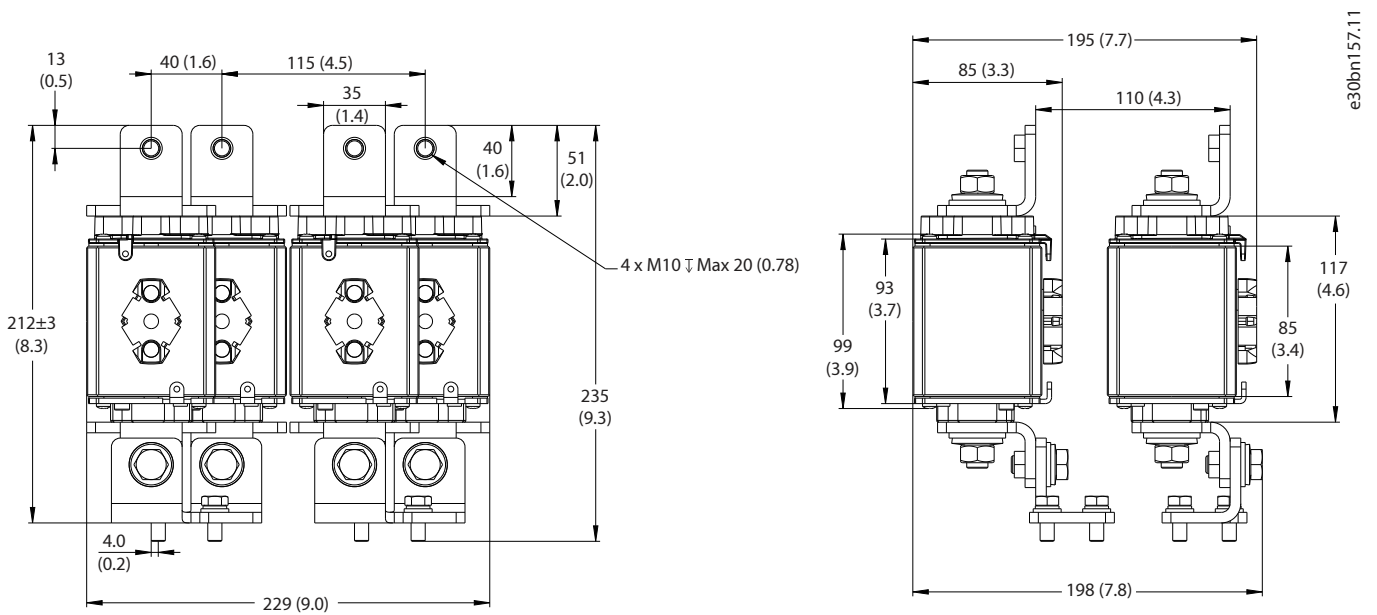

Figure 219: Dimensions of the Mersen DC Fuses, AR12L, Voltage Class G7 (380–690 V AC/500–1500 V DC), in mm (in)

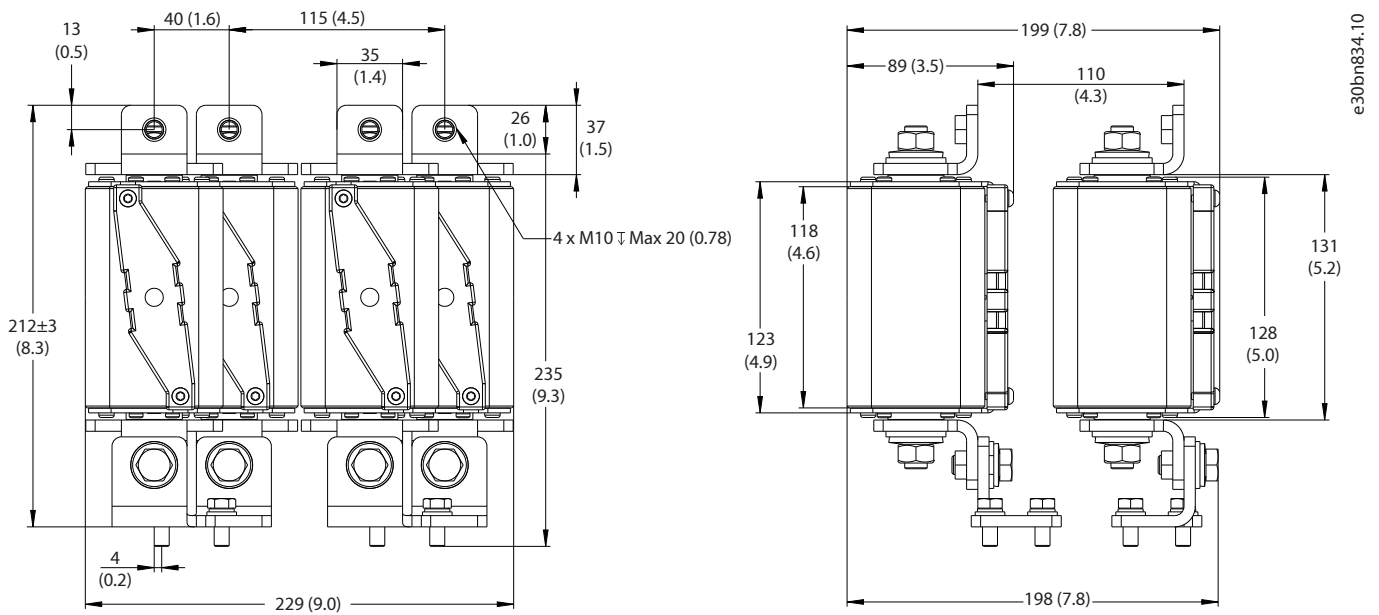

Figure 220: Dimensions of the Eaton DC Fuses, AR12L, Voltage Class G7 (380–690 V AC/500–1500 V DC), in mm (in)

10.2.40 Dimensions for the Control Panel Flush Mounting Kit

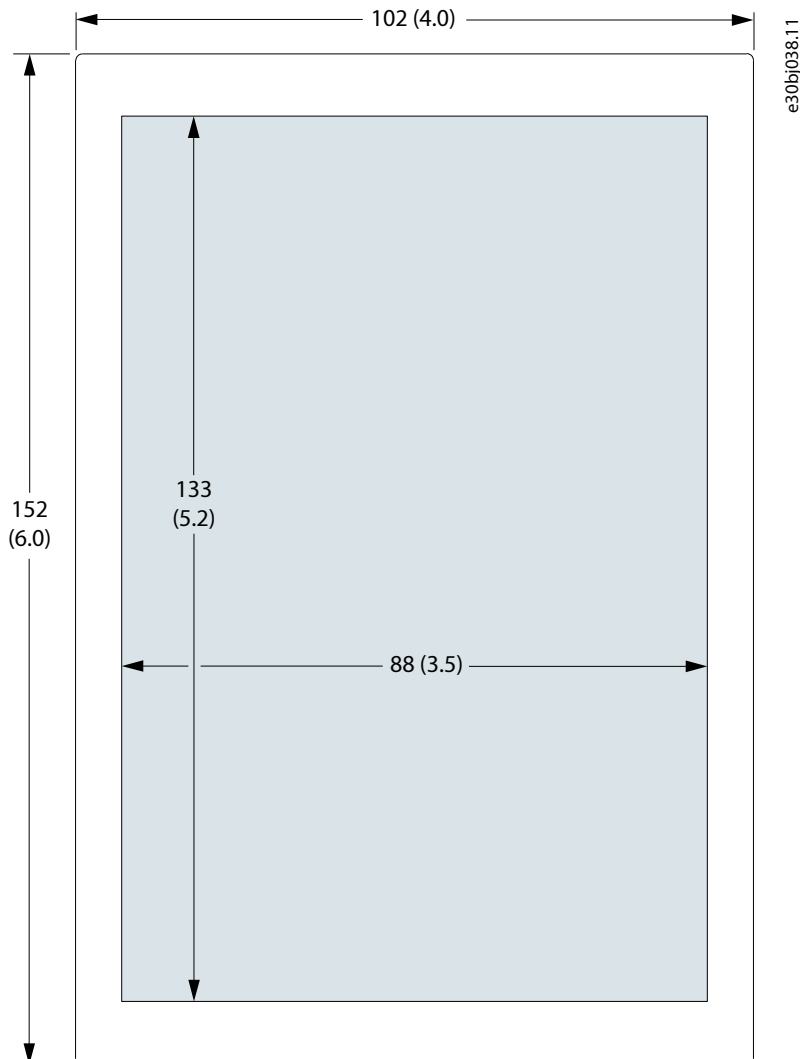

Figure 221: Flush Mounting Kit Drilling Template, mm (in)

10.2.41 Dimensions for the Control Panel Surface Mounting Kit

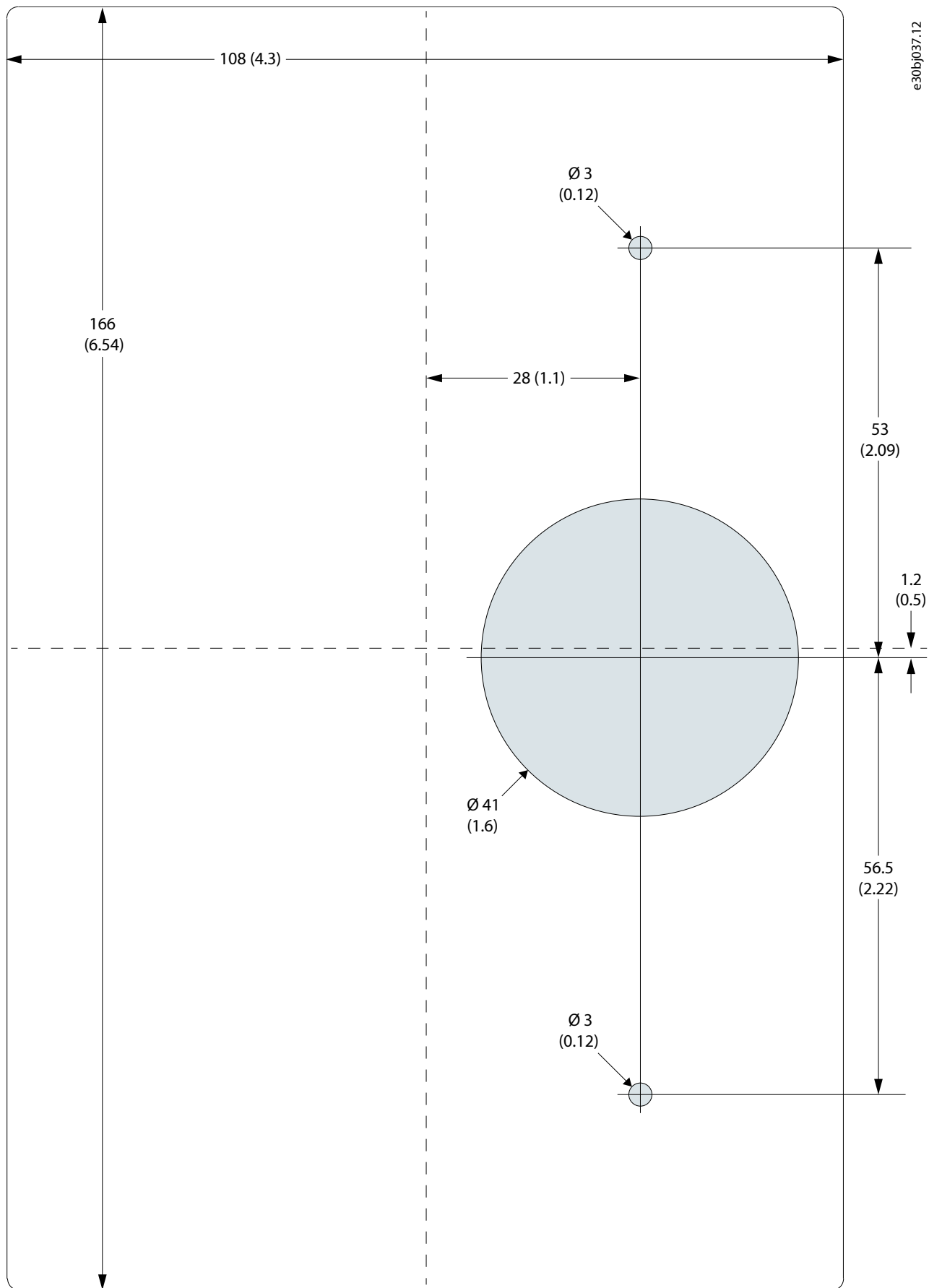
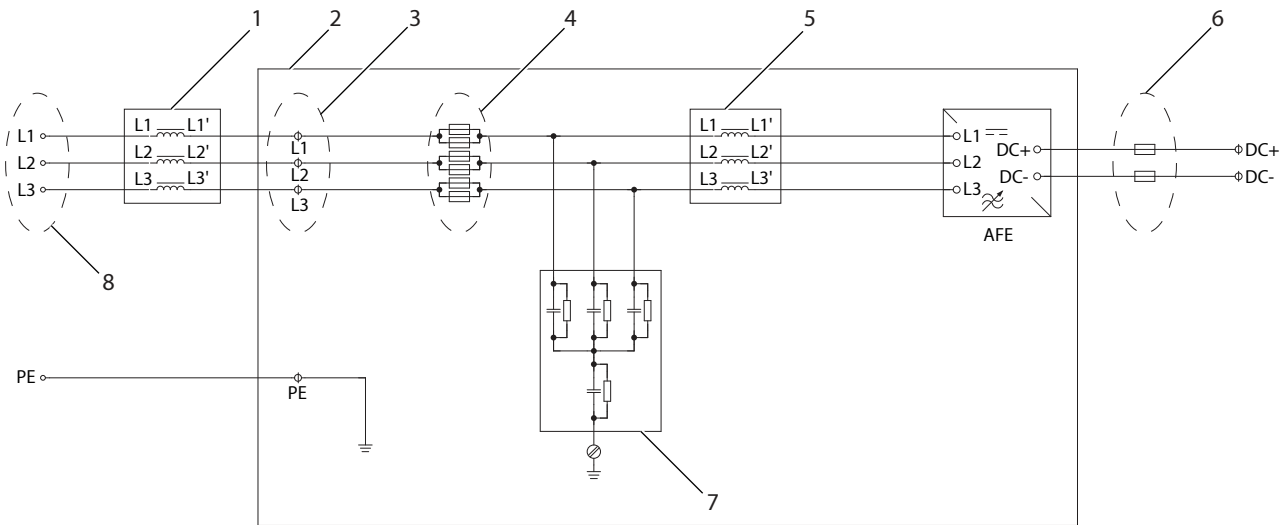

Figure 222: Surface Mounting Kit Drilling Template, mm (in)

10.3 Wiring Diagrams

10.3.1 Wiring Diagram, AFE/GC, AR10L and INU +AEZ1, IR10L



e30bg427.10

Figure 223: Wiring Diagram, AR10L and INU +AEZ1, IR10L

1	L Filter, grid side, loose option	2	AFE/GC module AR10L
3	Input terminals	4	AC fuses
5	LCL Filter choke, drive side	6	DC fuses, loose option
7	LCL Filter capacitors	8	Supply

10.3.2 Wiring Diagram, AFE/GC, AR12L and INU +AEZ1, IR12L

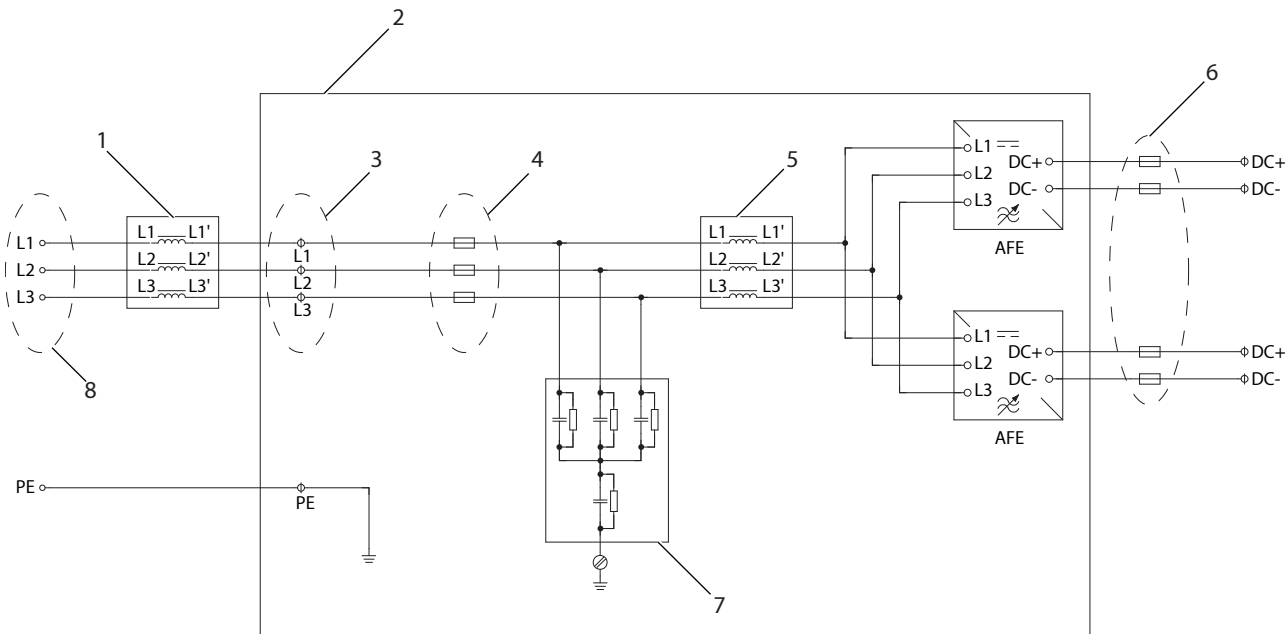

e30bg428.10

Figure 224: Wiring Diagram, AR12L and INU +AEZ1, IR12L

1	L Filter, grid side, loose option	2	AFE/GC module AR12L
3	Input terminals	4	AC fuses

5	LCL Filter choke, drive side	6	DC fuses, loose option
7	LCL Filter capacitors	8	Supply

10.3.3 Extended Wiring Diagram for Energy Storage Applications, GC, AR12L, Voltage Class G7

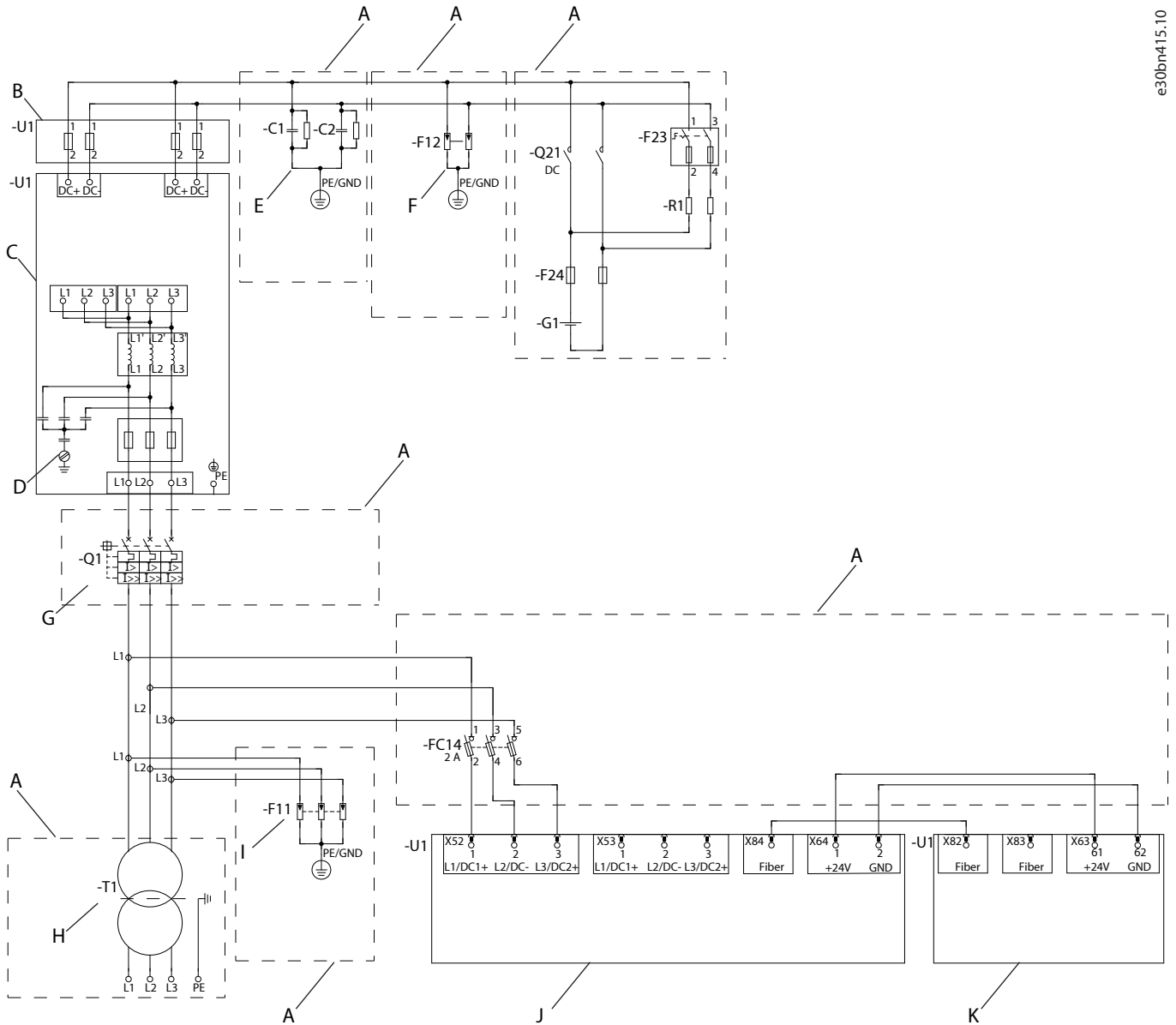

e30bn415.10

Figure 225: Extended Wiring Diagram for Energy Storage Applications, GC, AR12L, Voltage Class G7

A	Not included in the delivery	B	DC fuses +AKFX
C	Grid converter	D	Grounding screw ⁽¹⁾ (disconnected by default at the factory (EMC level C4))
E	Common-mode grounding capacitors ⁽²⁾	F	Surge suppressor (maximum 6kV for overvoltage category III) ⁽³⁾
G	Circuit breaker ⁽⁴⁾	H	Transformer ⁽⁵⁾

- I Surge suppressor (maximum 6 kV) (mandatory for UL 1741 J and outdoor installations)⁽⁶⁾
- J Voltage Measurement OC7V0
- K Option Extender Assembly OC7F2

- 1) The LC Filter ground capacitors are not connected to PE/GND by default.
- 2) Disconnect the LC filter ground capacitor from PE on the AC side (D) when common-mode ground capacitors are connected on the DC bus.
- 3) Apply fuse protection to the SPD according to the manufacturer's guidelines. Connect the SPD status contact to the grid converter digital input for monitoring, and set the parameters accordingly.
- 4) Hardwire the circuit breaker on/off and the fault indication contacts to the grid converter digital input, and set the parameters accordingly.
- 5) Equip the transformer with a static shield.
- 6) Apply fuse protection to the SPD according to the manufacturer's guidelines. Connect the SPD status contact to the grid converter digital input for monitoring, and set the parameters accordingly.

10.3.4 Wiring Diagram, INU, IR10L

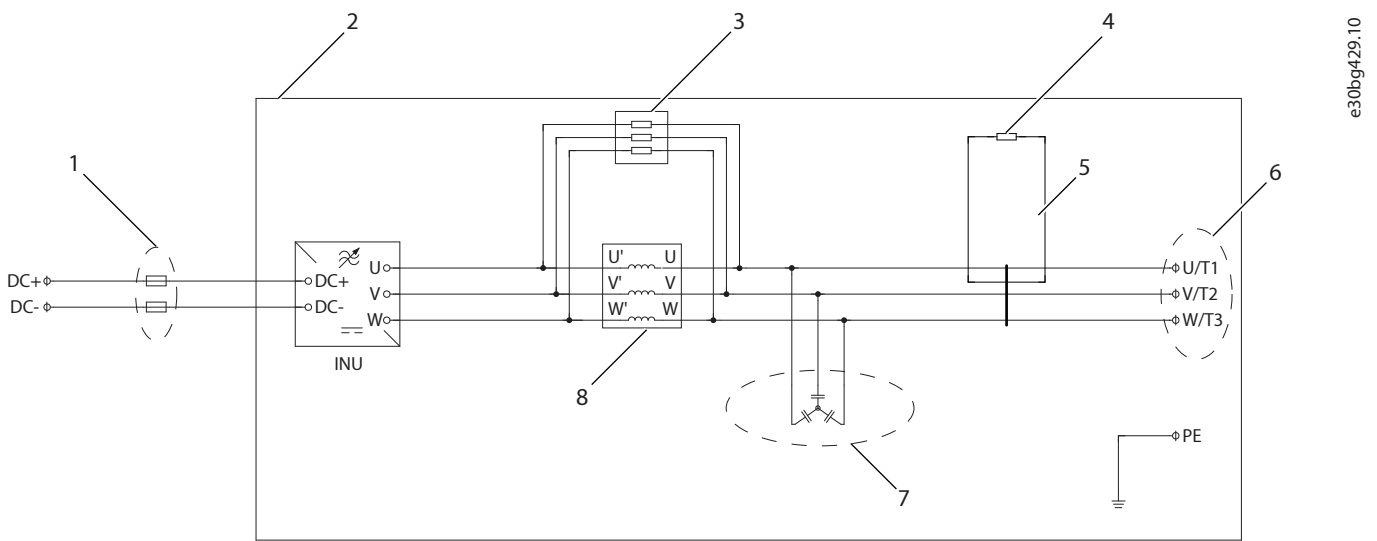
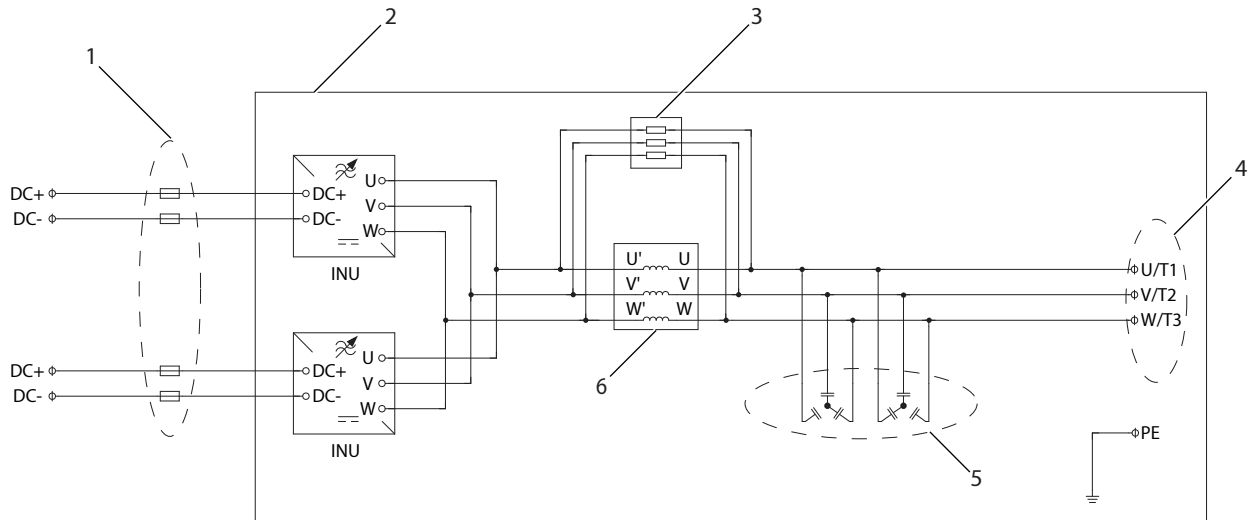

Figure 226: Wiring Diagram, IR10L

1	DC fuses, loose option	2	Inverter module IR10L
3	Damping resistors	4	Damping resistor
5	Common-mode Filter	6	Output terminals
7	dU/dt Filter capacitors	8	dU/dt Filter choke

10.3.5 Wiring Diagram, INU, IR12L



e30bg430.10

Figure 227: Wiring Diagram, IR12L

1	DC fuses, loose option	2	Inverter module IR12L
3	Damping resistors	4	Output terminals
5	dU/dt Filter capacitors	6	dU/dt Filter choke

10.3.6 Wiring Diagram, INU IR12L with Sine-wave Filter

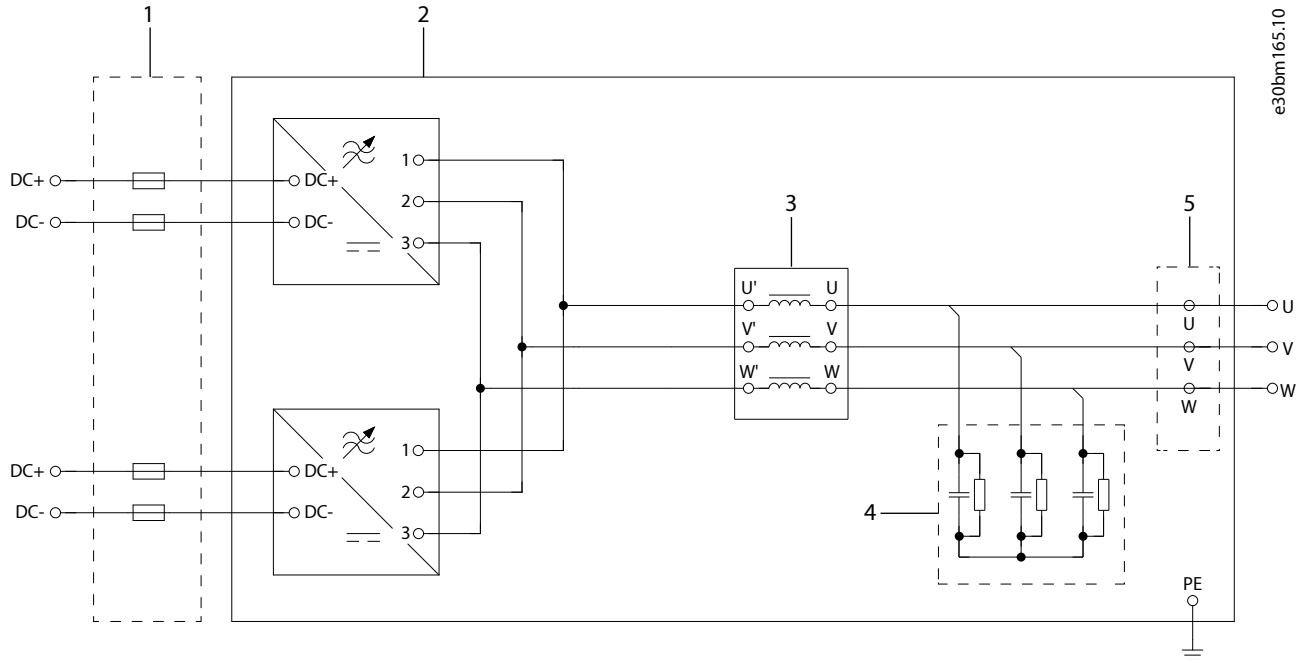

e30bm165.10

Figure 228: Wiring Diagram, INU IR12L with Sine-wave Filter

1	DC fuses, loose option	2	Inverter module
3	Sine-wave filter choke	4	Sine-wave filter capacitors
5	Output terminals		

10.3.7 Wiring Diagram, DC/DC Converter, DR10L

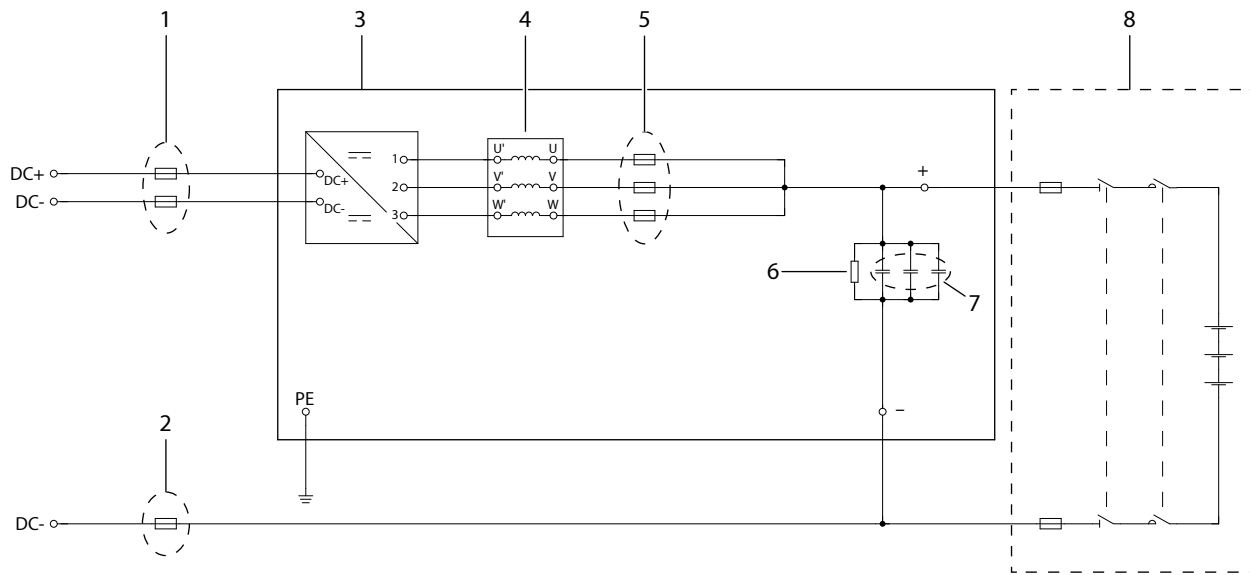

e30bk326.11

Figure 229: Wiring Diagram, DR10L

1	DC-bus fuses, option	2	Source DC- fuses, option
3	DC/DC converter module DR10L	4	DC-filter inductor
5	Source DC+ fuses, option	6	Discharging resistor
7	Capacitors	8	DC source/load

10.3.8 Wiring Diagram, DC/DC Converter, DR12L

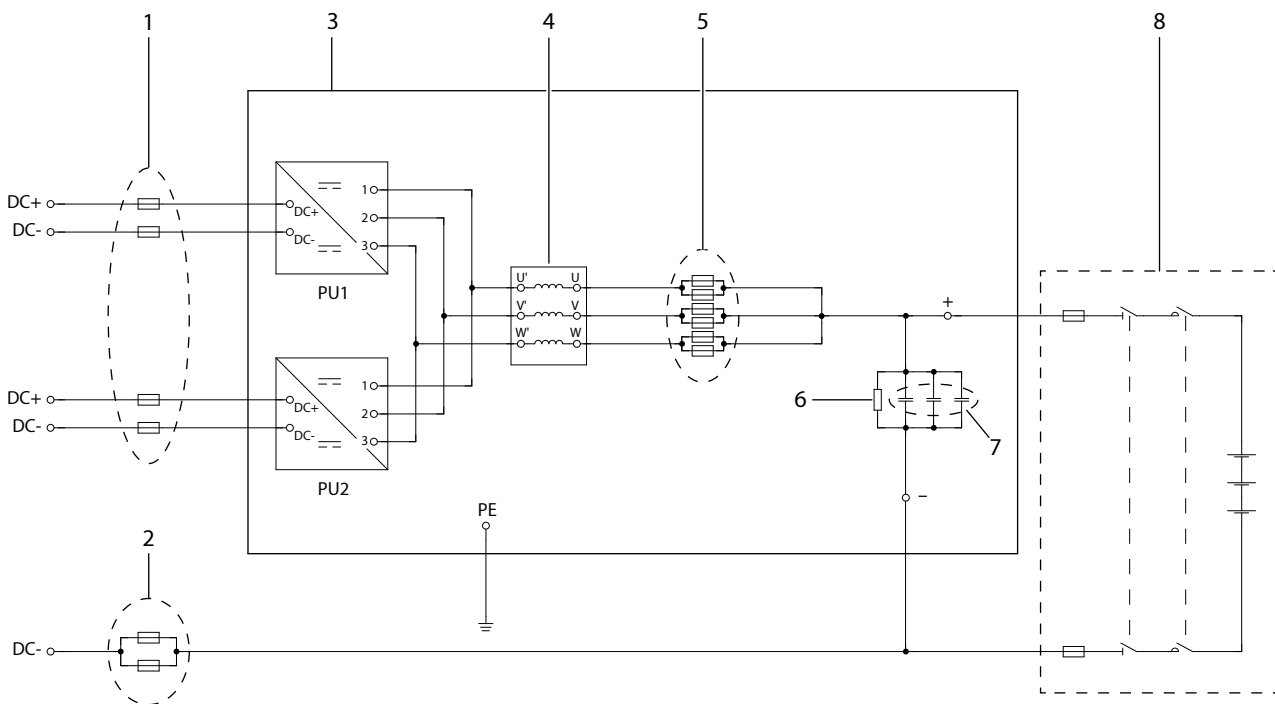

e30bk327.11

Figure 230: Wiring Diagram, DR12L

1	DC-bus fuses, option	2	Source DC- fuses, option
3	DC/DC converter module DR12L	4	DC-filter inductor
5	Source DC+ fuses, option	6	Discharging resistor
7	Capacitors	8	DC source/load

10.3.9 Wiring Diagram, BCU, BM10L/BR10L

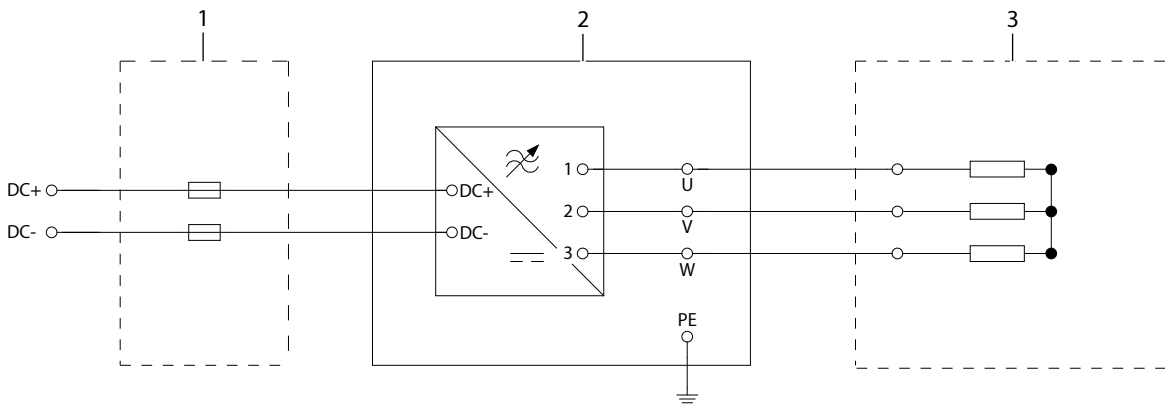

e30bn637.11

Figure 231: Wiring Diagram, BM10L/BR10L

1	DC fuses, option +AKFX	2	BM10L/BR10L
3	External brake resistors, 3 x resistors in star connection. The minimum cable length between the BCU and the brake resistors is 5 m.		

10.3.10 Wiring Diagram, BCU, BM12L/BR12L

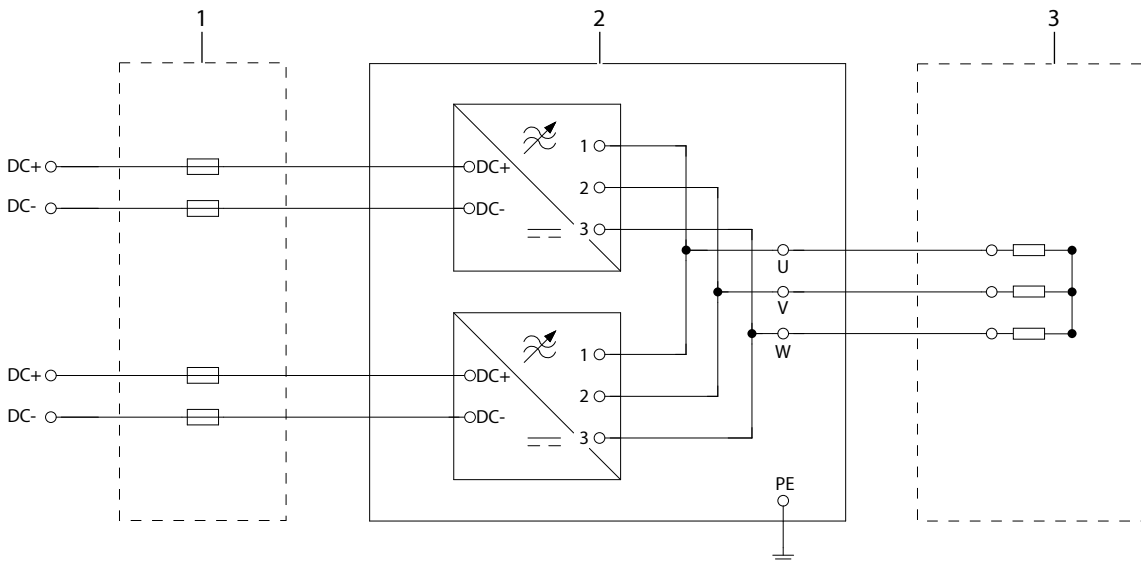

e30bn639.11

Figure 232: Wiring Diagram, BM12L/BR12L

1	DC fuses, option +AKFX	2	BM12L/BR12L
3	External brake resistors, 3 x resistors in star connection. The minimum cable length between the BCU and the brake resistors is 5 m.		

10.3.11 Wiring Diagram, SISO Filters, +AEZ2/+AEZ4, +AES2

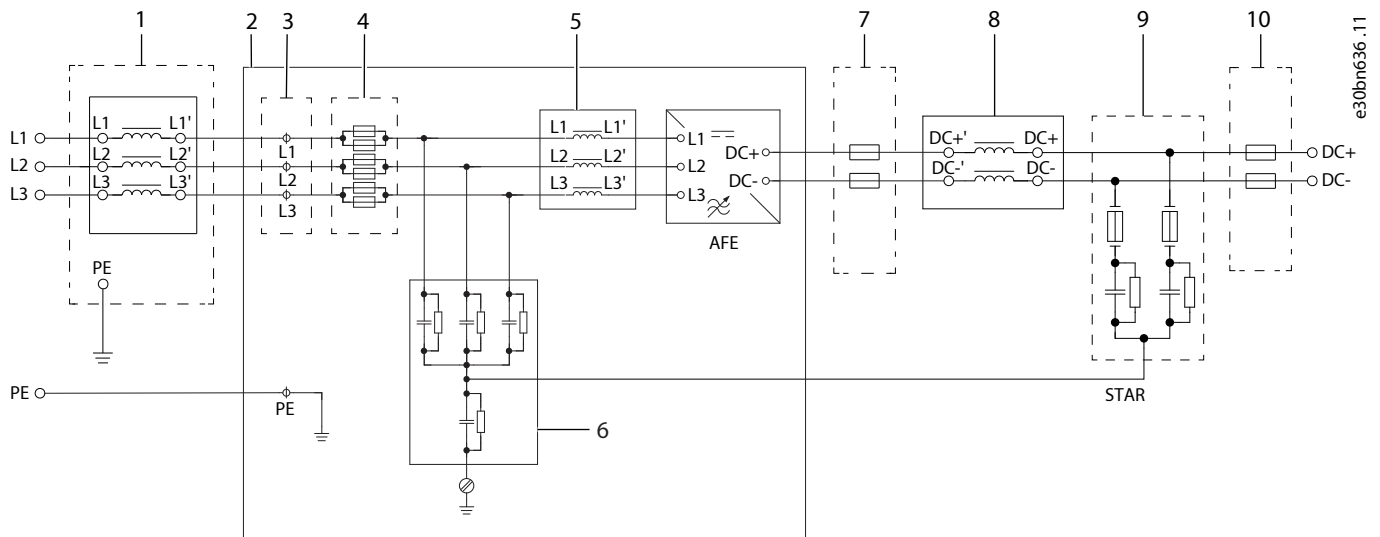

Figure 233: Wiring diagram of AR10L and +AEZ2/+AEZ4, 380 A

1	L filter (only included in +AEZ4)	2	AFE module AR10L
3	Input terminals	4	AC fuses
5	LC filter choke, drive side	6	LC filter capacitors
7	DC and SISO fuses, option +AKFS	8	Reactor
9	Feedback capacitors and fuses	10	DC and SISO fuses, option +AKFS

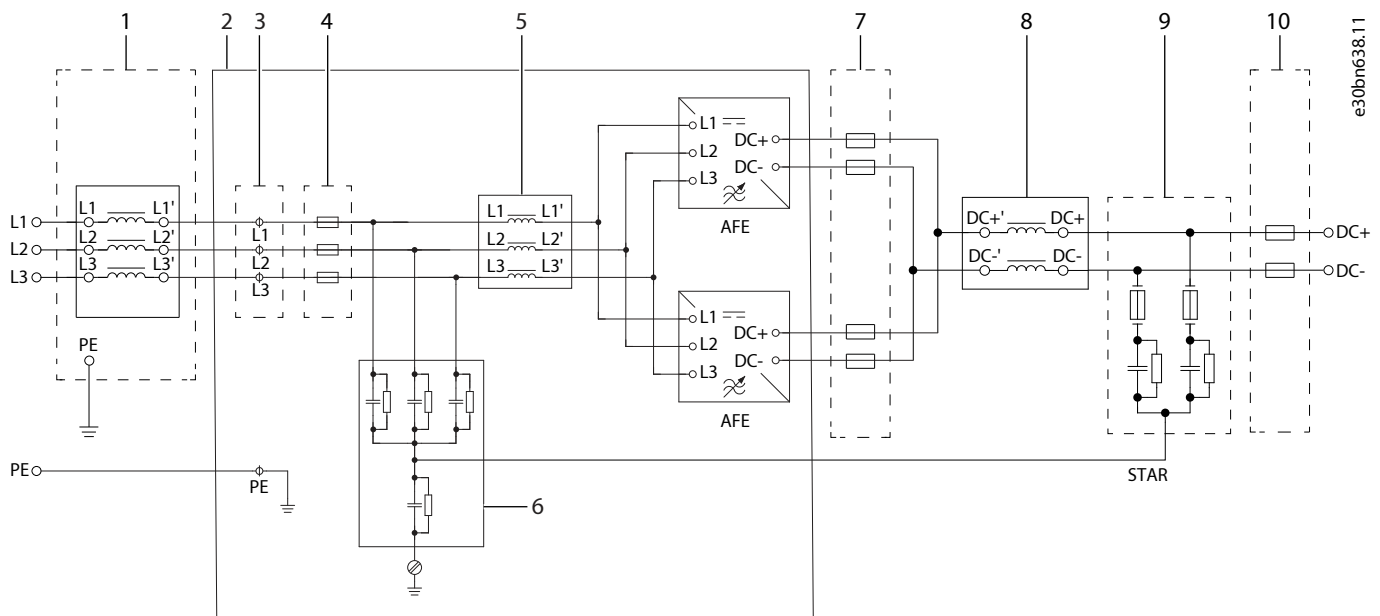
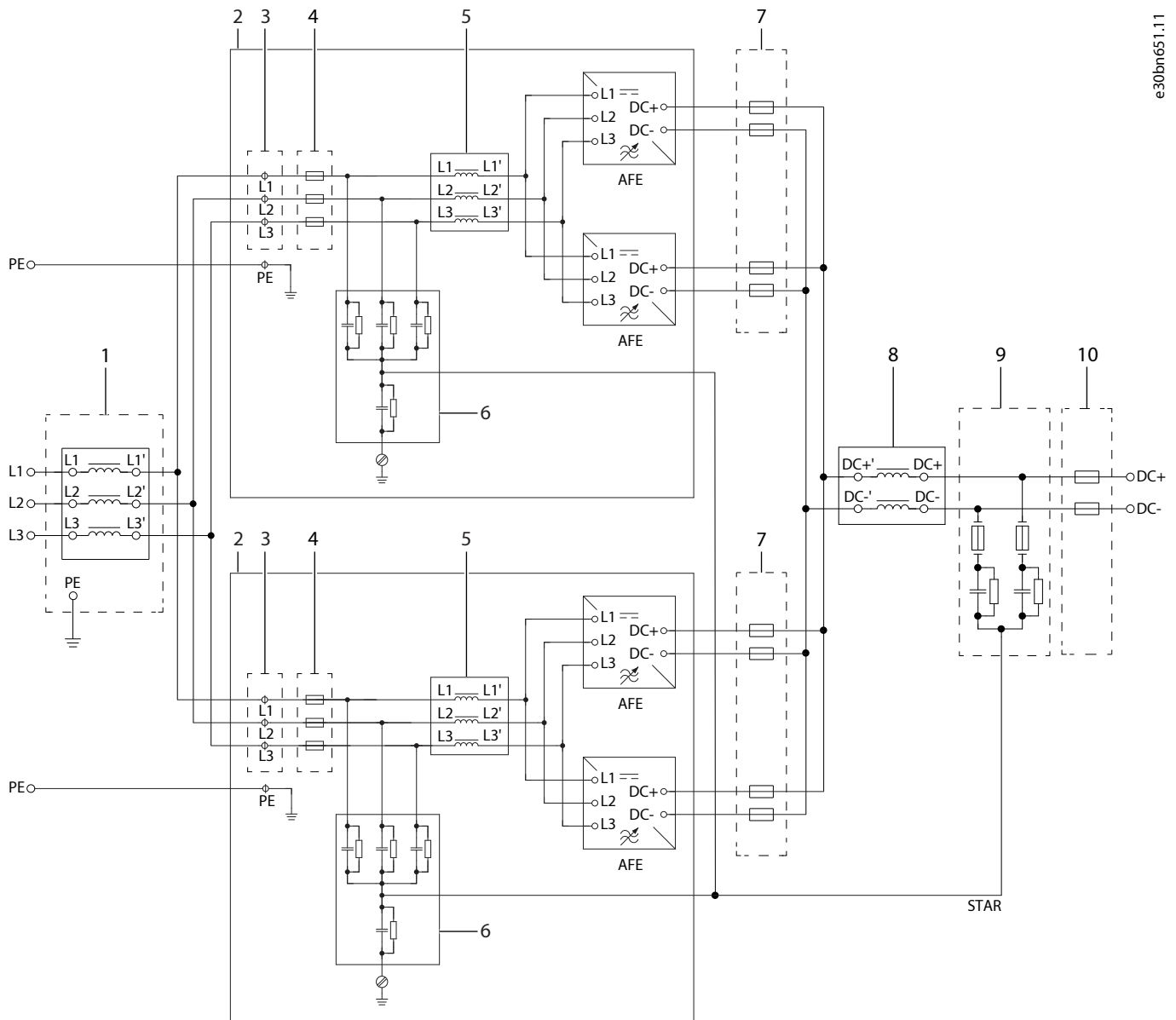

Figure 234: Wiring diagram of AR12L and +AEZ2/+AEZ4, 760 A

1	L filter (only included in +AEZ4)	2	AFE module AR12L
3	Input terminals	4	AC fuses
5	LC Filter choke, drive side	6	LC Filter capacitors

7	DC and SISO fuses, option +AKFS	8	Reactor
9	Feedback capacitors and fuses	10	DC and SISO fuses, option +AKFS



e30bn651.11

Figure 235: Wiring diagram of 2 x AR12L and +AEZ2/+AEZ4, 1500 A

1	L filter (only included in +AEZ4)	2	AFE module AR12L
3	Input terminals	4	AC fuses
5	LC Filter choke, drive side	6	LC Filter capacitors
7	DC and SISO fuses, option +AKFS	8	Reactor
9	Feedback capacitors and fuses	10	DC and SISO fuses, option +AKFS

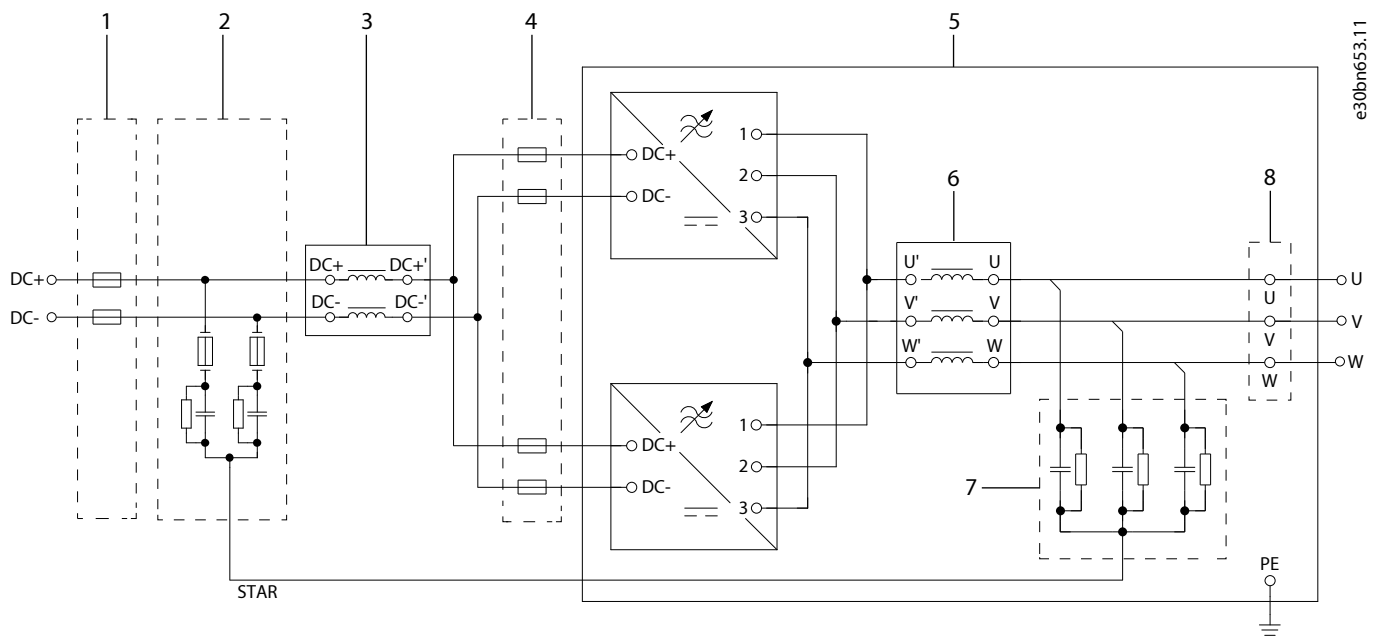

Figure 236: Wiring diagram of IR12L and +AES2, 730 A

1	DC and SISO fuses, option +AKFS	2	Feedback capacitors and fuses
3	Reactor	4	DC and SISO fuses, option +AKFS
5	Inverter module IR12L	6	Sine-wave filter choke
7	Sine-wave filter capacitors	8	Output terminals

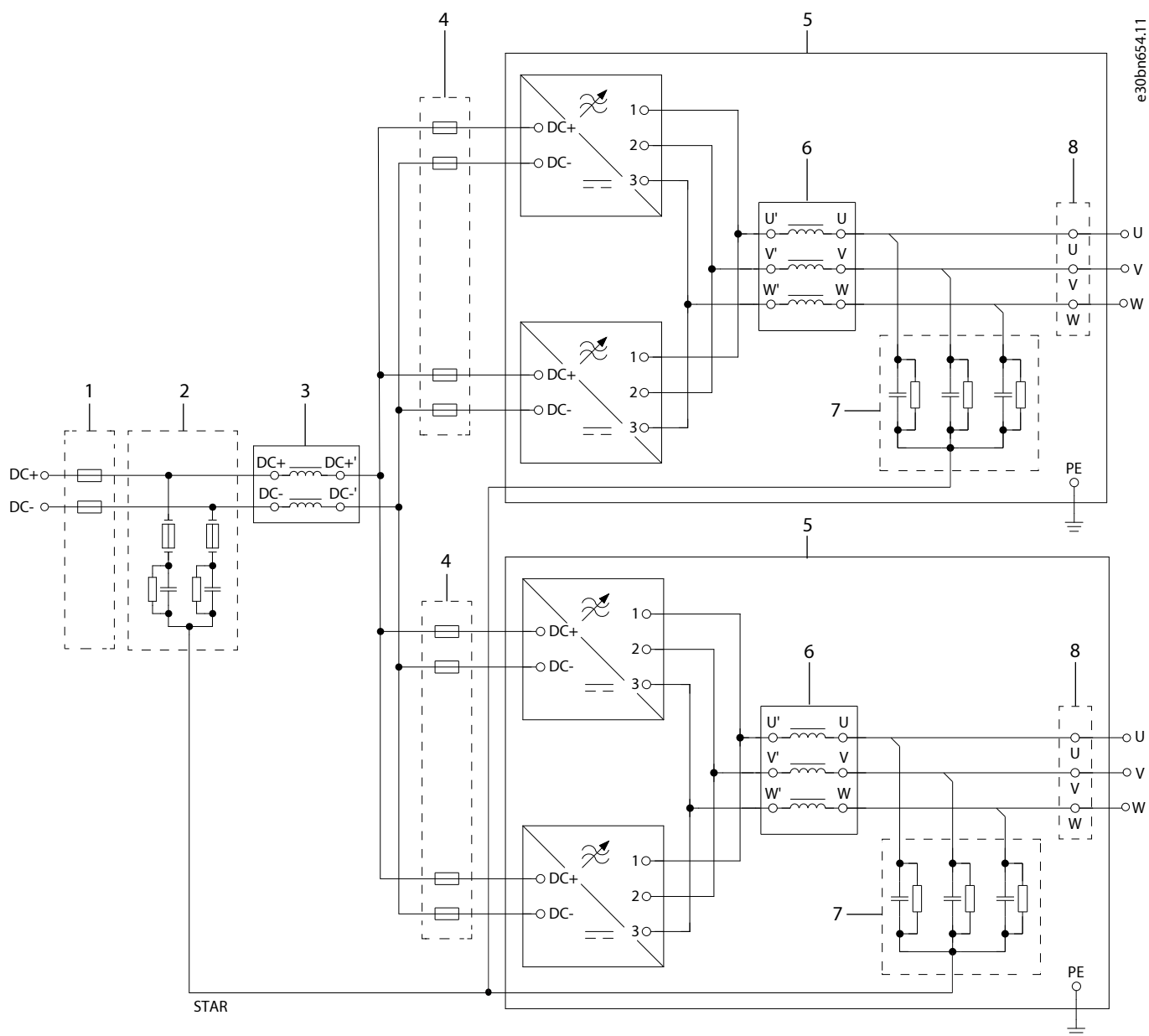

Figure 237: Wiring diagram of 2 x IR12L and +AES2 ,1400 A

1	DC and SISO fuses, option +AKFS	2	Feedback capacitors and fuses
3	Reactor	4	DC and SISO fuses, option +AKFS
5	Inverter module IR12L	6	Sine-wave filter choke
7	Sine-wave filter capacitors	8	Output terminals

10.3.12 Pre-charging Circuit, AR10L

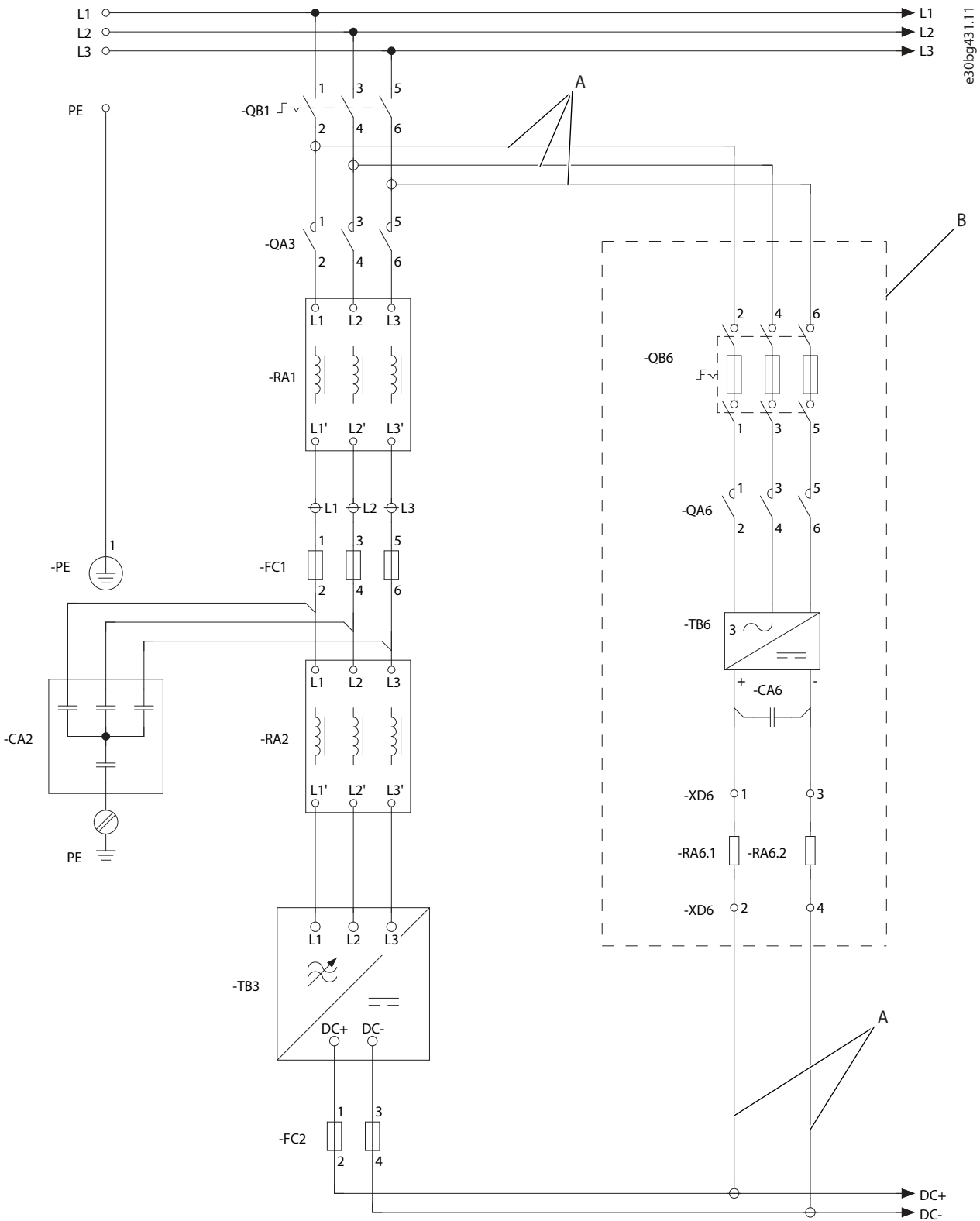

Figure 238: Pre-charging Circuit Diagram, AR10L

A Double-insulated cable

B Pre-charging circuit

10.3.13 Pre-charging Circuit, AR12L

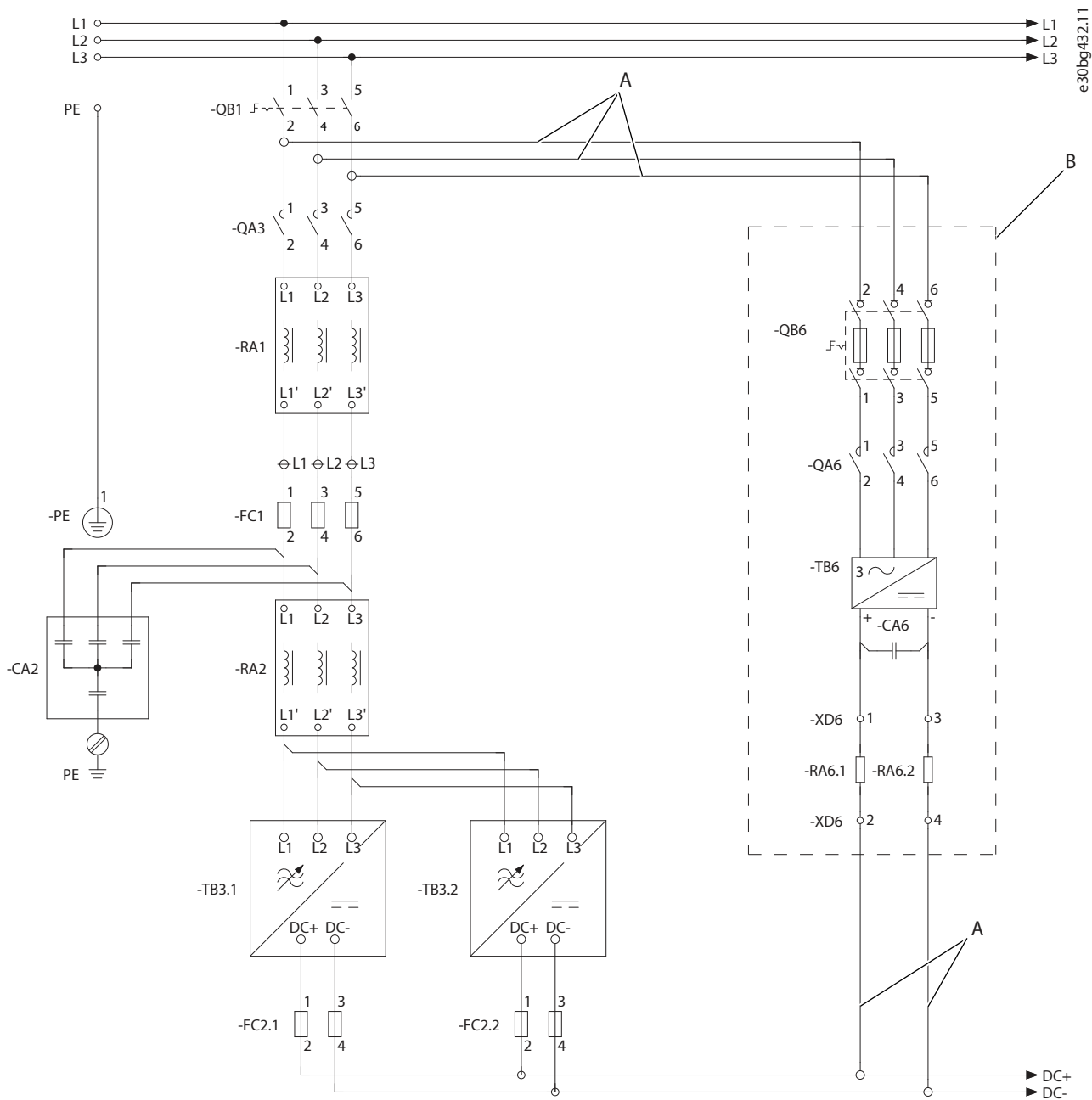
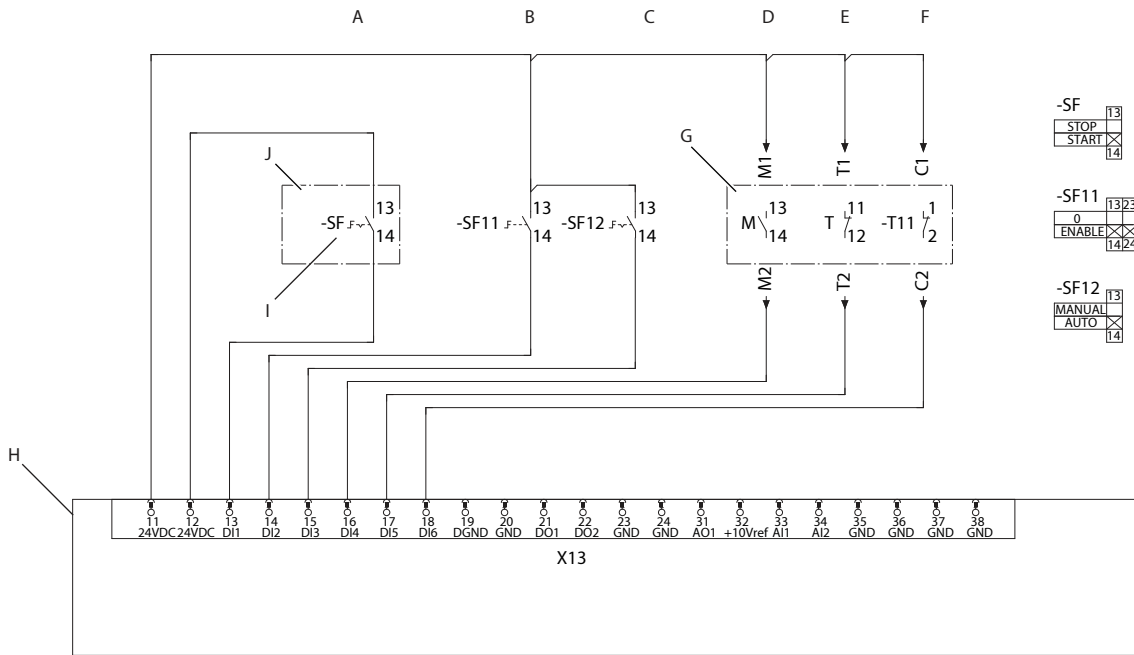

Figure 239: Pre-charging Circuit Diagram, AR12L (Only Available for Voltage Class 07, B5, and A5)

A Double-insulated cable

B Pre-charging circuit

10.3.14 Pre-charging Control Circuit Diagrams



e30bg433.11

Figure 240: Pre-charging Control Circuit Diagram

A	AFE or GC remote control start/stop	B	Mains 0-enable
C	Pre-charging man-auto	D	Main input device status
E	Main input device tripped (circuit breaker)	F	Cooling supervision
G	Status/supervision	H	I/O and Relay Option
I	AFE start/stop	J	Field connection

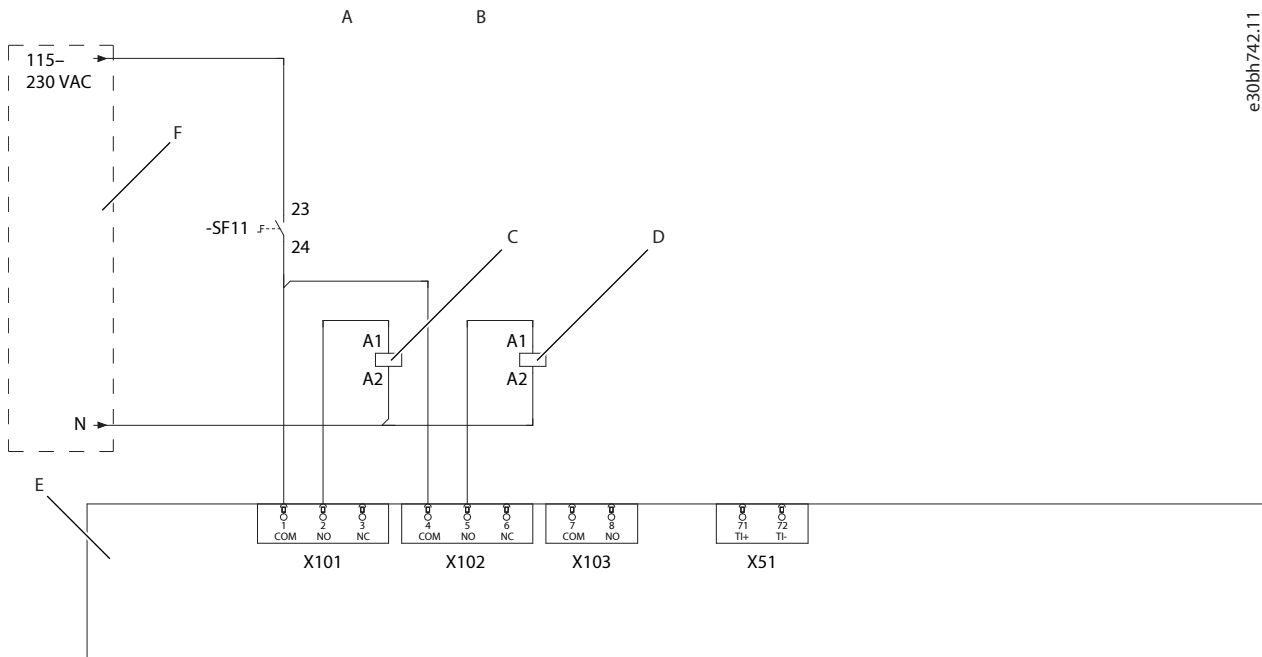

e30bh742.11

Figure 241: Pre-charging Control Circuit Diagram

A	Pre-charging contactor control	B	Main input device control
C	-QA6, Pre-charging contactor coil	D	-QA3, Mains contactor coil
E	I/O and Relay Option	F	Short-circuit protected supply

10.3.15 The Pre-charging Function

To avoid high inrush current to drive capacitors, pre-charge the drive before switching on main power.

The pre-charging function uses AFE or GC control unit I/Os and relays. The pre-charging function requires auxiliary voltage for the control unit and the pre-charging circuit. Pre-charging can be operated either locally (manually or automatically) or remotely (manually). Pre-charging is enabled by activating Digital Input 2. Select the MANUAL or AUTO mode by activating/deactivating Digital Input 3 (activated = AUTO). Select remote operation by activating Digital Input 1. Connect the input device, the contactor, or the circuit breaker, the auxiliary contacts to the control unit as described in [Figure 240](#). Connect also the cooling supervision signal from the cooling module if possible. The charging circuit is protected by fuses installed in the fuse-switch disconnect. Turn the switch ON.

Manual operation

Enable pre-charging and switch it to MANUAL mode. Pre-charging starts by pressing the Run button on the control panel of the AFE or grid converter module. The pre-charging contactor closes. When charging is done, the main input device closes and the pre-charging contactor opens. Charging must be performed again after a power outage.

Auto operation

Enable pre-charging and switch it to AUTO mode. Pre-charging starts immediately. The pre-charging contactor closes. When charging is done, the main input device closes and the pre-charging contactor opens. Charging is performed automatically after a power outage.

Remote operation

Enable pre-charging and set it to MANUAL mode. Pre-charging starts by activating Digital Input 1. The AFE or grid converter module starts and the pre-charging contactor closes. When charging is done, the main input device closes and the pre-charging contactor opens. Charging must be performed again after a power outage.

10.3.16 Wiring Diagrams of the +24 V Supply for the Control Unit

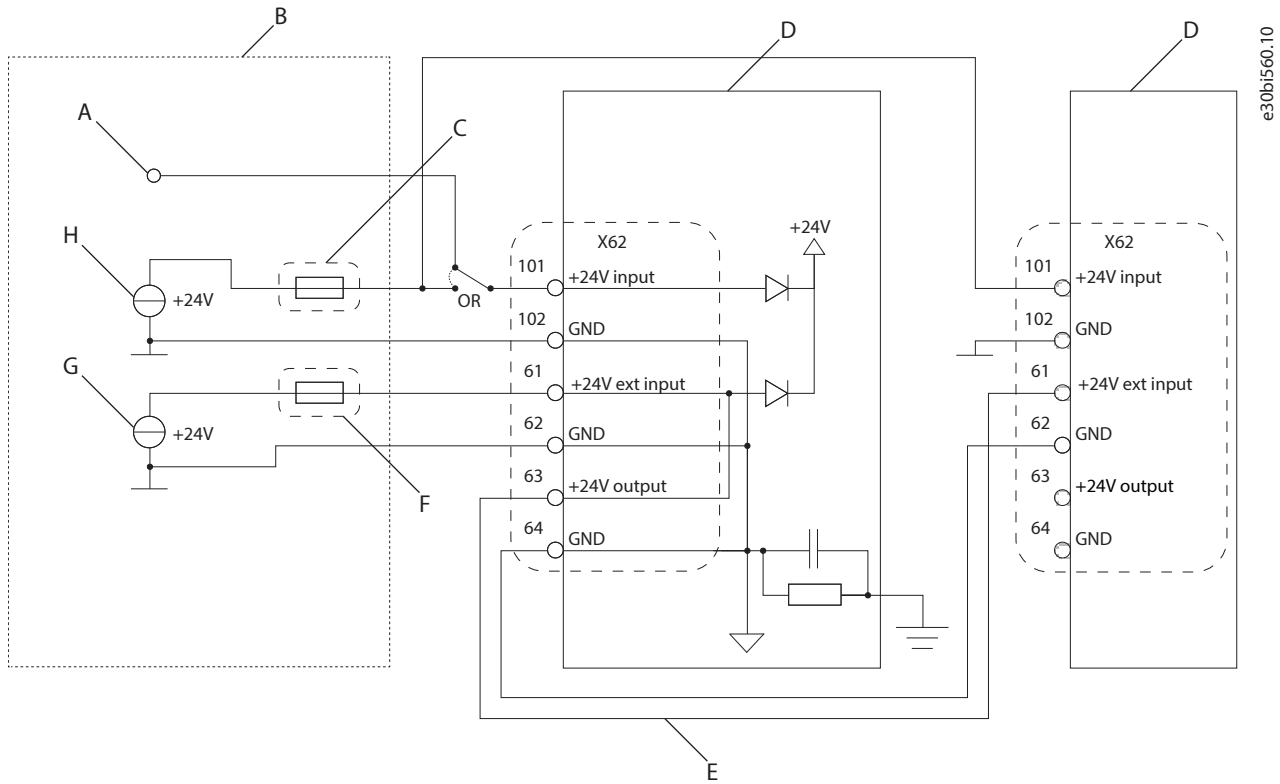
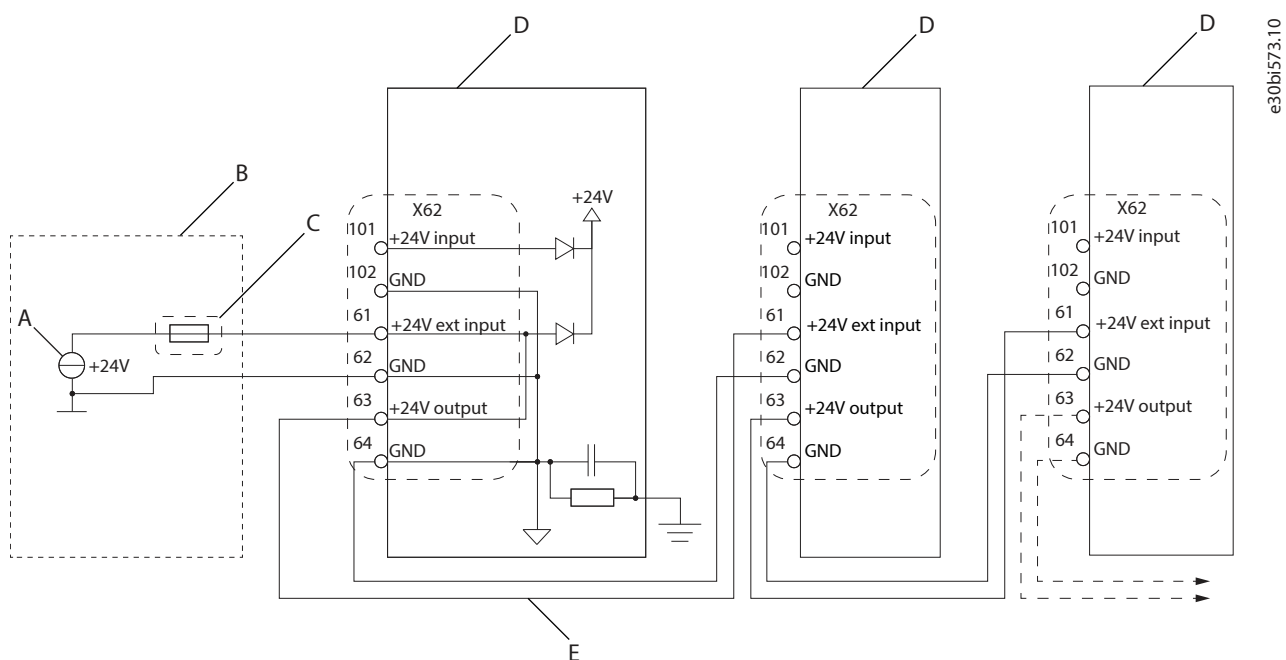

Figure 242: Wiring Diagram of Redundant Supplies

A	Internal +24 V supply (if provided)	B	Reference design, redundant +24 V power
C	3 A fuse	D	Control board
E	Power daisy-chaining	F	Fuse (Fuse rating depends on the complete daisy-chained system configuration. Maximum 10 A.)
G	Primary external supply	H	External redundant supply



e30bi573.10

Figure 243: Wiring Diagram of a Daisy-chained +24 V Supply for the Control Units

A	Normal external supply	B	Reference design, daisy-chained +24 V power
C	Fuse (Fuse rating depends on the complete daisy-chained system configuration. Maximum 10 A.)	D	Control board
E	Power daisy-chaining		

10.3.17 Wiring Diagram for Connecting Surge Protection Device Monitoring and Circuit Breaker Control to I/O and Relay Option, Grid Converter, Voltage Class G7

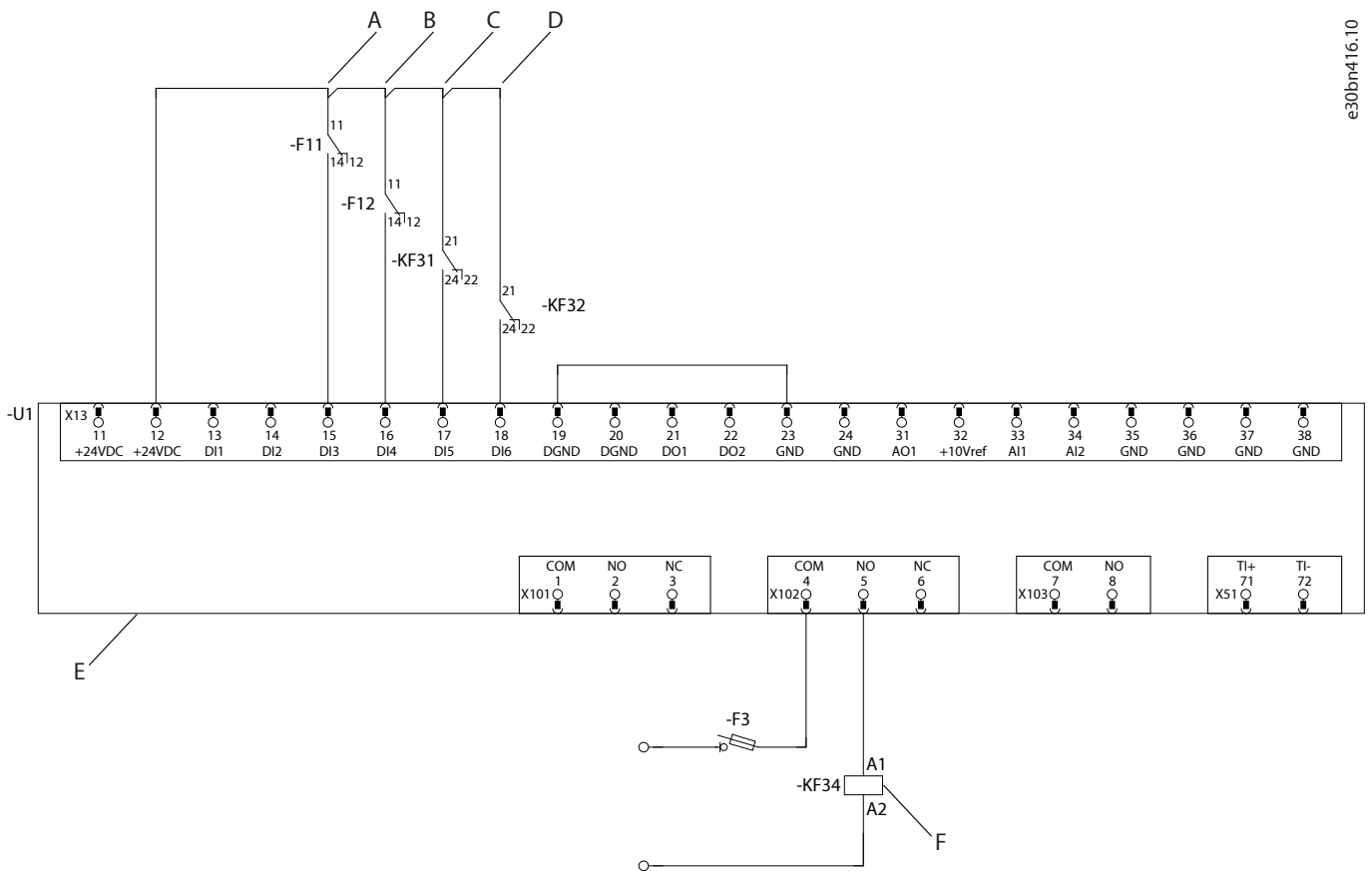

e30bn416.10

Figure 244: Wiring Diagram for Connecting Surge Protection Device Monitoring and Circuit Breaker Control to I/O and Relay Option, Grid Converter, Voltage Class G7

A	AC surge suppressor monitoring	B	DC surge suppressor monitoring
C	Mains circuit breaker on/off status	D	Mains circuit breaker trip status
E	I/O and Relay Option OC7C1	F	Mains circuit breaker open/close

10.4 Cable Sizes

10.4.1 General Information on the Cable Tables

The IEC cable sizing is based on these conditions:

- Ambient temperature of 40 °C (104 °F).
- Cables laid side by side on cable ladders.
- Maximum 9 cables per ladder.
- 3 ladders on top of each other with a minimum spacing of 300 mm (11.8 in).

Use cable insulation that can withstand a temperature of at least 90 °C (194 °F). In other conditions, refer to the local safety regulations, the input voltage, and the load current of the drive.

The UL cable sizing is based on these conditions:

- Ambient temperature of 40 °C (104 °F). Conductor sizing is based on NEC table 310.15(B)(16).

- 90 °C (194 °F) rated copper cables.
 - Multicore cables installed in cable ducts.
 - If cable ducts are not used, keep sufficient spacing between the cables.
 - Do not stack or bundle the cables without proper spacing for longer than 600 mm (24 in).
- In other conditions, refer to the local safety regulations, the input voltage, and the load current of the drive.



NOTE: Use symmetrical cabling with system modules connected in parallel. Each module must have the same number of cables with equal cross-section.

The cable size tables for the liquid-cooled system modules can be found with these links.

- [10.4.2 Field Cable Sizes for AFE and GC Modules, 380–500 V AC](#)
- [10.4.3 Field Cable Sizes for AFE and GC Modules, 525–690 V AC](#)
- [10.4.4 Field Cable Sizes for GC Modules, 380–690 V AC](#)
- [10.4.5 Bolt Sizes for the Internal AC Busbars/Cables for AFE and GC Modules, 380–690 V AC](#)
- [10.4.6 Cable Sizes for the Internal AC Cables for AFE and GC Modules, 380–690 V AC](#)
- [10.4.7 Internal AC Busbar Sizing within the Enclosure of the AFE/GC Modules](#)
- [10.4.8 Field Cable Sizes for INU Module, 380–500 V AC](#)
- [10.4.9 Field Cable Sizes for INU Module, 525–690 V AC](#)
- [10.4.10 Source Cable Sizes for DC/DC Converter Modules, 640–1100 V DC](#)
- [10.4.11 Marine Cable Sizes for AFE or GC Modules 380–500 V AC](#)
- [10.4.12 Marine Cable Sizes for AFE or GC Modules 525–690 V AC](#)
- [10.4.13 Marine Cable Sizes for INU Modules 380–500 V AC](#)
- [10.4.14 Marine Cable Sizes for INU Modules 525–690 V AC](#)
- [10.4.15.2 Mains Cable Sizes for AFE or GC Modules, UL 600 V](#)
- [10.4.15.4 Motor Cable Sizes for Inverter Modules, UL 575 V](#)
- [10.4.16 Brake Cable Sizes for BCU, 525–690 V AC](#)
- [10.4.17 Internal DC Cable Sizes for SISO Filters](#)

10.4.2 Field Cable Sizes for AFE and GC Modules, 380–500 V AC

The AFE and GC modules with integration units do not have field cabling terminals for mains. Connect the AFE and GC modules to adequate size field cabling terminals or switching device.

Table 52: Field Cable Sizes for AFE and GC Modules, 380-500 V AC

Model code	Frame ⁽¹⁾	I _N [A]	Mains cable Cu [mm ²]	Mains cable Al [mm ²]
iC7-60SLxxA5-271AE00Fx	A_10L	277	3x185+120	3x240+72
iC7-60SLxxA5-317AE00Fx		324	3x185+120	2x(3x150+41)
iC7-60SLxxA5-400AE00Fx		409	2x(3x120+70)	2x(3x185+57)
iC7-60SLxxA5-460AE00Fx		470	2x(3x120+70)	2x(3x185+57)

Table 52: Field Cable Sizes for AFE and GC Modules, 380-500 V AC - (continued)

Model code	Frame ⁽¹⁾	I _N [A]	Mains cable Cu [mm ²]	Mains cable Al [mm ²]
iC7-60SLxxA5-520AE00Fx	A_12L	531	2x(3x150+70)	2x(3x240+72)
iC7-60SLxxA5-580AE00Fx		593	2x(3x185+95)	2x(3x240+72)
iC7-60SLxxA5-650AE00Fx		664	4x(3x120+70)	4x(3x150+41)
iC7-60SLxxA5-730AE00Fx		746	4x(3x120+70)	4x(3x150+41)
iC7-60SLxxA5-816AE00Fx		833	4x(3x120+70)	4x(3x185+57)
iC7-60SLxxA5-970AE00Fx		991	4x(3x150+70)	4x(3x185+57)
iC7-60SLxxA5-1040E00Fx	2 x A_12L	1062	4x(3x150+70)	4x(3x240+72)
iC7-60SLxxA5-1210E00Fx		1236	4x(3x185+95)	4x(3x240+72)
iC7-60SLxxA5-1300E00Fx		1328	6x(3x150+70)	6x(3x185+57)
iC7-60SLxxA5-1410E00Fx		1440	6x(3x150+70)	6x(3x185+57)
iC7-60SLxxA5-1630E00Fx		1664	6x(3x185+95)	8x(3x185+57)
iC7-60SLxxA5-1900E00Fx		1940	6x(3x185+95)	8x(3x185+57)
iC7-60SLxxA5-2080E00Fx	3 x A_12L	2124	9x(3x150+70)	9x(3x185+57)
iC7-60SLxxA5-2200E00Fx		2246	9x(3x150+70)	9x(3x240+72)
iC7-60SLxxA5-2450E00Fx		2501	9x(3x185+95)	9x(3x240+72)
iC7-60SLxxA5-2800E00Fx		2859	9x(3x185+95)	9x(3x240+72)
iC7-60SLxxA5-3120E00Fx	4 x A_12L	3185	12x(3x185+95)	12x(3x240+72)
iC7-60SLxxA5-3270E00Fx		3338	12x(3x185+95)	12x(3x240+72)
iC7-60SLxxA5-3720E00Fx		3798	12x(3x185+95)	12x(3x240+72)
iC7-60SLxxA5-4160E00Fx	5 x A_12L	4247	15x(3x185+95)	15x(3x240+72)
iC7-60SLxxA5-4650E00Fx		4747	15x(3x185+95)	15x(3x240+72)
iC7-60SLxxA5-5200E00Fx	6 x A_12L	5309	18x(3x185+95)	18x(3x240+72)
iC7-60SLxxA5-5550E00Fx		5666	18x(3x185+95)	18x(3x240+72)
iC7-60SLxxA5-5930E00Fx	7 x A_12L	6054	21x(3x185+95)	21x(3x240+72)
iC7-60SLxxA5-6450E00Fx		6585	21x(3x185+95)	21x(3x240+72)
iC7-60SLxxA5-6900E00Fx	8 x A_12L	7044	24x(3x185+95)	24x(3x240+72)
iC7-60SLxxA5-7370E00Fx		7524	24x(3x185+95)	24x(3x240+72)

1) AM10L, AR10L, AM12L, or AR12L

10.4.3 Field Cable Sizes for AFE and GC Modules, 525–690 V AC

The AFE and GC modules with integration units do not have field cabling terminals for mains. Connect the AFE and GC modules to adequate size field cabling terminals or switching device.

[Table 53](#) for cable recommendation is also applicable to the voltage class B5.

Table 53: Field Cable Sizes for AFE and GC Modules, 525–690 V AC

Model code	Frame ⁽¹⁾	I _N [A]	Mains cable Cu [mm ²]	Mains cable Al [mm ²]
iC7-60SLxx07-236AE00Fx	Ax10L	241	3x150+70	3x240+72
iC7-60SLxxB5-261AE00Fx ⁽²⁾		267	3x185+95	3x240+72
iC7-60SLxx07-300AE00Fx		307	3x240+120	2x(3x120+41)
iC7-60SLxxB5-325AE00Fx ⁽²⁾		332	3x240+120	2x(3x150+41)
iC7-60SLxx07-334AE00Fx		341	2x(3x120+70)	2x(3x150+41)
iC7-60SLxx07-380AE00Fx		388	2x(3x120+70)	2x(3x185+57)
iC7-60SLxx07-425AE00Fx	Ax12L	434	2x(3x120+70)	2x(3x185+57)
iC7-60SLxx07-475AE00Fx		485	2x(3x150+70)	2x(3x240+72)
iC7-60SLxx07-530AE00Fx		542	2x(3x185+70)	3x(3x150+41)
iC7-60SLxx07-595AE00Fx		608	2x(3x240+120)	3x(3x185+57)
iC7-60SLxx07-670AE00Fx		684	4x(3x120+70)	4x(3x150+41)
iC7-60SLxx07-760AE00Fx		776	4x(3x120+70)	4x(3x150+41)
iC7-60SLxx07-850AE00Fx	2 x Ax12L	868	4x(3x120+70)	4x(3x185+57)
iC7-60SLxx07-945AE00Fx		965	4x(3x150+70)	4x(3x240+72)
iC7-60SLxx07-1040E00Fx		1062	4x(3x185+95)	6x(3x150+41)
iC7-60SLxx07-1230E00Fx		1256	4x(3x240+120)	6x(3x185+57)
iC7-60SLxx07-1325E00Fx		1353	8x(3x120+70)	8x(3x150+41)
iC7-60SLxx07-1500E00Fx		1532	8x(3x120+70)	8x(3x150+41)
iC7-60SLxx07-1700E00Fx	3 x Ax12L	1736	6x(3x185+95)	9x(3x150+41)
iC7-60SLxx07-1800E00Fx		1838	6x(3x240+120)	9x(3x185+57)
iC7-60SLxx07-2000E00Fx		2042	6x(3x240+120)	9x(3x240+72)
iC7-60SLxx07-2250E00Fx		2297	12x(3x120+70)	9x(3x240+72)
iC7-60SLxx07-2500E00Fx	4 x Ax12L	2552	8x(3x240+120)	12x(3x185+57)
iC7-60SLxx07-2650E00Fx		2706	12x(3x150+70)	12x(3x240+72)
iC7-60SLxx07-2940E00Fx		3002	12x(3x150+70)	12x(3x240+72)
iC7-60SLxx07-3120E00Fx	5 x Ax12L	3185	10x(3x240+120)	15x(3x185+57)
iC7-60SLxx07-3600E00Fx		3675	15x(3x150+70)	15x(3x240+72)
iC7-60SLxx07-3900E00Fx	6 x Ax12L	3982	18x(3x150+70)	18x(3x240+72)
iC7-60SLxx07-4320E00Fx		4410	18x(3x150+70)	18x(3x240+72)
iC7-60SLxx07-4750E00Fx	7 x Ax12L	4849	21x(3x150+70)	21x(3x240+72)
iC7-60SLxx07-5040E00Fx		5145	21x(3x150+70)	21x(3x240+72)
iC7-60SLxx07-5400E00Fx	8 x Ax12L	5513	24x(3x150+70)	24x(3x240+72)
iC7-60SLxx07-5750E00Fx		5870	24x(3x150+70)	24x(3x240+72)

1) AM10L, AR10L, AM12L, or AR12L

2) Only for B5 voltage class.

10.4.4 Field Cable Sizes for GC Modules, 380–690 V AC

Table 54: Field Cable Sizes for GC Modules, 380–690 V AC

Model code	Frame	I_N [A]	Mains cable Cu [mm ²]	Mains cable Al [mm ²]
iC7-60SLGCG7-760A	AR12L	776	4x(3x120+70)	4x(3x185+57)
iC7-60SLGCG7-970A		1 000	4x(3x150+70)	4x(3x185+57)
iC7-60SLGCG7-1500	2 x AR12L	1532	6x(3x150+70)	8x(3x185+57)
iC7-60SLGCG7-1700		1736	6x(3x185+70)	8x(3x185+57)
iC7-60SLGCG7-1900		1950	6x(3x185+70)	8x(3x185+57)
iC7-60SLGCG7-2450	3 x AR12L	2501	9x(3x185+95)	9x(3x240+72)
iC7-60SLGCG7-2800		2900	9x(3x185+95)	9x(3x240+72)
iC7-60SLGCG7-3270	4 x AR12L	3338	12x(3x185+95)	12x(3x240+72)
iC7-60SLGCG7-3720		3850	12x(3x185+95)	12x(3x240+72)
iC7-60SLGCG7-4160	5 x AR12L	4247	15x(3x185+95)	15x(3x240+72)
iC7-60SLGCG7-4650		4800	15x(3x185+95)	15x(3x240+72)
iC7-60SLGCG7-5550	6 x AR12L	5750	18x(3x185+95)	18x(3x240+72)
iC7-60SLGCG7-6450	7 x AR12L	6650	21x(3x185+95)	21x(3x240+72)
iC7-60SLGCG7-7370	8 x AR12L	7600	24x(3x185+95)	24x(3x240+72)

10.4.5 Bolt Sizes for the Internal AC Busbars/Cables for AFE and GC Modules, 380–690 V AC

Table 55: Bolt Sizes for the AFE and GC Modules

Frame ⁽¹⁾	Bolt size for internal cable or busbar	Number of grounding terminals/bolt size
Ax10L	M10	1/M8
Ax12L	M10	1/M8
2 x Ax12L	M10	2/M8
3 x Ax12L	M10	3/M8
4 x Ax12L	M10	4/M8
5 x Ax12L	M10	5/M8
6 x Ax12L	M10	6/M8
7 x Ax12L	M10	7/M8
8 x Ax12L	M10	8/M8

1) AM10L, AR10L, AM12L, or AR12L

10.4.6 Cable Sizes for the Internal AC Cables for AFE and GC Modules, 380–690 V AC

The AC terminals of the frame AR10L are designed for cable connection. Use cables between the active front-end (AFE) or grid converter (GC), and the grid side L terminals, or the switching device.

The cable sizing is based on the following conditions:

- Ambient temperature 60 °C (140 °F).
- Use cable insulation that can withstand a temperature of at least 105 °C (221 °F).

Minimum internal cable sizes for voltage class A5, see [Table 56](#).

Minimum internal cable sizes for voltage class 07 and, B5, see [Table 57](#).

Table 56: Minimum Internal Cable Sizes, Voltage Class A5

Model code	Frame	I _N [A]	Cable Cu [mm ²]
iC7-60SLxxA5-271AE00Fx	A_10L	277	1x120
iC7-60SLxxA5-317AE00Fx		324	1x150
iC7-60SLxxA5-400AE00Fx		409	1x185
iC7-60SLxxA5-460AE00Fx		470	1x185

Table 57: Minimum Internal Cable Sizes, Voltage Class 07, and B5

Model code	Frame	I _N [A]	Cable Cu [mm ²]
iC7-60SLxx07-236AE00Fx	A_10L	241	1x120
iC7-60SLxxB5-261AE00Fx		267	1x120
iC7-60SLxx07-300AE00Fx		307	1x150
iC7-60SLxxB5-325AE00Fx		332	1x150
iC7-60SLxx07-334AE00Fx		341	1x150
iC7-60SLxx07-380AE00Fx		388	1x150

10.4.7 Internal AC Busbar Sizing within the Enclosure of the AFE/GC Modules

The power terminals of the frame AR12L are designed for busbar connection. Use busbars or cables between the grid converter terminals and the field cabling terminals or the switching device.

Size the busbar size according to the switchgear standard IEC 61439-1 and -2 or follow the local regulations. For North American installations, size the busbars according to UL508A and the National Electrical Code (NEC).

If busbars are selected with a cross-sectional area smaller than the values specified in the applicable standard, perform a temperature-rise test for the enclosure.

The starting point for sizing the busbars with 2 m/s forced air cooling:

- Single AR12L: 60x10 mm busbar per phase
- Multiple AR12L: 80x10 mm busbar per phase per AR12L with parallel busbars (for example: 2 x (80x10) for 2 x AR12L)

This starting point with forced air cooling is with smaller cross-sections than in the switchgear standard.

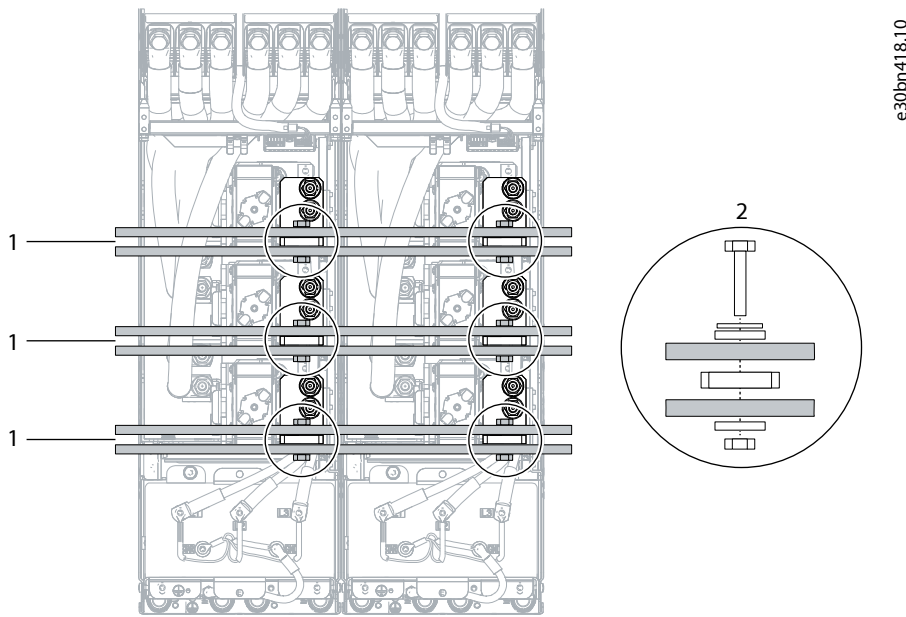

e30bn418.10

Figure 245: Mounting the AC Busbars to 2 x AR12L

1 80x10 mm busbars

2 Mounting the busbars

10.4.8 Field Cable Sizes for INU Module, 380–500 V AC

Table 58: Field Cable Sizes for INU Modules, 380-500 V AC

Model code	Frame ⁽¹⁾	I_N [A]	Motor cable Cu [mm ²]	Motor cable Al [mm ²]	Terminal max. cable size	Number of grounding terminals/ bolt size	Max. number of cables/ bolt size
iC7-60SLINA5-206AE00Fx	I_10L	211	3x120+70	3x185+57	300 Cu/Al	1/M8	2/M10
iC7-60SLINA5-245AE00Fx		251	3x150+70	3x185+57	300 Cu/Al	1/M8	2/M10
iC7-60SLINA5-302AE00Fx		309	3x185+95	3x240+72	300 Cu/Al	1/M8	2/M10
iC7-60SLINA5-385AE00Fx		394	3x240+120	2x(3x150+41)	300 Cu/Al	1/M8	2/M10
iC7-60SLINA5-480AE00Fx		490	2x(3x150+70)	2x(3x185+57)	300 Cu/Al	1/M8	2/M10
iC7-60SLINA5-520AE00Fx		531	2x(3x150+70)	2x(3x240+72)	300 Cu/Al	1/M8	2/M10
iC7-60SLINA5-658AE00Fx	I_12L	672	2x(3x240+120)	3x(3x185+57)	300 Cu/Al	1/M8	4/M10
iC7-60SLINA5-730AE00Fx		746	2x(3x240+120)	4x(3x150+41)	300 Cu/Al	1/M8	4/M10
iC7-60SLINA5-820AE00Fx		838	2x(3x240+120)	4x(3x185+57)	300 Cu/Al	1/M8	4/M10
iC7-60SLINA5-880AE00Fx		899	4x(3x150+70)	4x(3x185+57)	300 Cu/Al	1/M8	4/M10
iC7-60SLINA5-1000E00Fx		1021	4x(3x150+70)	4x(3x240+72)	300 Cu/Al	1/M8	4/M10
iC7-60SLINA5-1270E00Fx	2 x I_12L	1297	4x(3x185+95)	6x(3x185+57)	300 Cu/Al	2/M8	8/M10
iC7-60SLINA5-1460E00Fx		1491	4x(3x240+120)	6x(3x240+72)	300 Cu/Al	2/M8	8/M10
iC7-60SLINA5-1630E00Fx		1664	4x(3x240+120)	6x(3x240+72)	300 Cu/Al	2/M8	8/M10
iC7-60SLINA5-1760E00Fx		1797	8x(3x150+70)	8x(3x185+57)	300 Cu/Al	2/M8	8/M10
iC7-60SLINA5-1960E00Fx		2001	8x(3x150+70)	8x(3x240+72)	300 Cu/Al	2/M8	8/M10

Table 58: Field Cable Sizes for INU Modules, 380-500 V AC - (continued)

Model code	Frame ⁽¹⁾	I _N [A]	Motor cable Cu [mm ²]	Motor cable Al [mm ²]	Terminal max. cable size	Number of grounding terminals/ bolt size	Max. number of cables/ bolt size
iC7-60SLINA5-2130E00Fx	3 x I_12L	2195	9x(3x150+70)	9x(3x185+57)	300 Cu/Al	3/M8	12/M10
iC7-60SLINA5-2340E00Fx		2389	9x(3x150+70)	9x(3x240+72)	300 Cu/Al	3/M8	12/M10
iC7-60SLINA5-2510E00Fx		2563	9x(3x185+95)	9x(3x240+72)	300 Cu/Al	3/M8	12/M10
iC7-60SLINA5-2880E00Fx		2940	9x(3x185+95)	12x(3x185+57)	300 Cu/Al	3/M8	12/M10
iC7-60SLINA5-3120E00Fx	4 x I_12L	3185	12x(3x185+95)	12x(3x240+72)	300 Cu/Al	4/M8	16/M10
iC7-60SLINA5-3420E00Fx		3492	12x(3x185+95)	12x(3x240+72)	300 Cu/Al	4/M8	16/M10
iC7-60SLINA5-3820E00Fx		3900	12x(3x185+95)	16x(3x185+57)	300 Cu/Al	4/M8	16/M10
iC7-60SLINA5-4140E00Fx	5 x I_12L	4227	15x(3x185+95)	20x(3x185+57)	300 Cu/Al	5/M8	20/M10
iC7-60SLINA5-4500E00Fx		4594	15x(3x185+95)	20x(3x185+57)	300 Cu/Al	5/M8	20/M10
iC7-60SLINA5-4750E00Fx		4849	15x(3x185+95)	20x(3x185+57)	300 Cu/Al	5/M8	20/M10
iC7-60SLINA5-5220E00Fx	6 x I_12L	5329	18x(3x185+95)	24x(3x185+57)	300 Cu/Al	6/M8	24/M10
iC7-60SLINA5-5680E00Fx		5799	18x(3x185+95)	24x(3x185+57)	300 Cu/Al	6/M8	24/M10

1) IM10L, IR10L, IM12L, or IR12L

10.4.9 Field Cable Sizes for INU Module, 525–690 V AC

Table 59 for cable recommendation is also applicable to the voltage class B5.

Table 59: Field Cable Sizes for INU Module, 525–690 V AC

Model code	Frame ⁽¹⁾	I _N [A]	Motor cable Cu [mm ²]	Motor cable Al [mm ²]	Terminal max. cable size	Number of grounding terminals/ bolt size	Max. number of cables/ bolt size
iC7-60SLIN07-170E00Fx	Ix10L	174	3x120+70	3x185+57	300 Cu/Al	1/M8	2/M10
iC7-60SLINB5-206AE00Fx ⁽²⁾		211	3x120+70	3x185+57	300 Cu/Al	1/M8	2/M10
iC7-60SLIN07-208AE00Fx		213	3x120+70	3x185+57	300 Cu/Al	1/M8	2/M10
iC7-60SLINB5-245AE00Fx ⁽²⁾		251	3x150+70	2x(3x95+29)	300 Cu/Al	1/M8	2/M10
iC7-60SLIN07-261E00Fx		267	3x185+95	2x(3x95+29)	300 Cu/Al	1/M8	2/M10
iC7-60SLINB5-302AE00Fx ⁽²⁾		309	3x185+95	2x(3x120+41)	300 Cu/Al	1/M8	2/M10
iC7-60SLIN07-325E00Fx		332	3x240+120	2x(3x120+41)	300 Cu/Al	1/M8	2/M10
iC7-60SLIN07-365E00Fx		373	2x(3x120+70)	2x(3x150+41)	300 Cu/Al	1/M8	2/M10
iC7-60SLINB5-385AE00Fx ⁽²⁾		394	2x(3x120+70)	2x(3x150+41)	300 Cu/Al	1/M8	2/M10
iC7-60SLIN07-416E00Fx		425	2x(3x120+70)	2x(3x185+57)	300 Cu/Al	1/M8	2/M10

Table 59: Field Cable Sizes for INU Module, 525–690 V AC - (continued)

Model code	Frame ⁽¹⁾	I _N [A]	Motor cable Cu [mm ²]	Motor cable Al [mm ²]	Terminal max. cable size	Number of grounding terminals/ bolt size	Max. number of cables/ bolt size
iC7-60SLIN07-465E00Fx	1x12L	475	2x(3x150+70)	2x(3x240+72)	300 Cu/Al	1/M8	4/M10
iC7-60SLIN07-525E00Fx		536	2x(3x185+95)	3x(3x150+41)	300 Cu/Al	1/M8	4/M10
iC7-60SLIN07-590E00Fx		603	2x(3x240+120)	3x(3x185+57)	300 Cu/Al	1/M8	4/M10
iC7-60SLIN07-650E00Fx		664	2x(3x240+120)	3x(3x185+57)	300 Cu/Al	1/M8	4/M10
iC7-60SLIN07-730E00Fx		746	3x(3x150+70)	4x(3x150+41)	300 Cu/Al	1/M8	4/M10
iC7-60SLIN07-820E00Fx		838	4x(3x120+70)	4x(3x185+57)	300 Cu/Al	1/M8	4/M10
iC7-60SLIN07-945E00Fx	2 x 1x12L	965	4x(3x150+70)	4x(3x240+72)	300 Cu/Al	2/M8	8/M10
iC7-60SLIN07-1060E00Fx		1 083	4x(3x185+95)	6x(3x150+41)	300 Cu/Al	2/M8	8/M10
iC7-60SLIN07-1230E00Fx		1 256	4x(3x240+120)	6x(3x185+57)	300 Cu/Al	2/M8	8/M10
iC7-60SLIN07-1400E00Fx		1 430	4x(3x240+120)	8x(3x150+41)	300 Cu/Al	2/M8	8/M10
iC7-60SLIN07-1500E00Fx		1 532	8x(3x120+70)	8x(3x150+41)	300 Cu/Al	2/M8	8/M10
iC7-60SLIN07-1640E00Fx		1 675	8x(3x120+70)	8x(3x185+57)	300 Cu/Al	2/M8	8/M10
iC7-60SLIN07-1795E00Fx	3 x 1x12L	1 833	9x(3x120+70)	9x(3x185+57)	300 Cu/Al	3/M8	12/M10
iC7-60SLIN07-2080E00Fx		2 124	9x(3x150+70)	12x(3x150+41)	300 Cu/Al	3/M8	12/M10
iC7-60SLIN07-2300E00Fx		2 348	12x(3x120+70)	12x(3x150+41)	300 Cu/Al	3/M8	12/M10
iC7-60SLIN07-2460E00Fx		2 512	12x(3x120+70)	12x(3x185+57)	300 Cu/Al	3/M8	12/M10
iC7-60SLIN07-2830E00Fx	4 x 1x12L	2 889	12x(3x150+70)	16x(3x150+41)	300 Cu/Al	4/M8	16/M10
iC7-60SLIN07-3050E00Fx		3 114	16x(3x120+70)	16x(3x185+57)	300 Cu/Al	4/M8	16/M10
iC7-60SLIN07-3260E00Fx		3 328	16x(3x120+70)	16x(3x185+57)	300 Cu/Al	4/M8	16/M10
iC7-60SLIN07-3500E00Fx	5 x 1x12L	3 573	15x(3x150+70)	20x(3x150+41)	300 Cu/Al	5/M8	20/M10
iC7-60SLIN07-4035E00Fx		4 119	20x(3x120+70)	20x(3x185+57)	300 Cu/Al	5/M8	20/M10
iC7-60SLIN07-4400E00Fx	6 x 1x12L	4 492	18x(3x150+70)	24x(3x150+41)	300 Cu/Al	6/M8	24/M10
iC7-60SLIN07-4850E00Fx		4 951	24x(3x120+70)	24x(3x185+57)	300 Cu/Al	6/M8	24/M10
iC7-60SLIN07-5300E00Fx	7 x 1x12L	5 411	28x(3x120+70)	28x(3x150+41)	300 Cu/Al	7/M8	28/M10
iC7-60SLIN07-5600E00Fx		5 717	28x(3x120+70)	28x(3x185+57)	300 Cu/Al	7/M8	28/M10
iC7-60SLIN07-6100E00Fx	8 x 1x12L	6 227	32x(3x120+70)	32x(3x185+57)	300 Cu/Al	8/M8	32/M10
iC7-60SLIN07-6400E00Fx		6 534	32x(3x120+70)	32x(3x185+57)	300 Cu/Al	8/M8	32/M10

1) IM10L, IR10L, IM12L, or IR12L

2) Only for B5 voltage class.

10.4.10 Source Cable Sizes for DC/DC Converter Modules, 640–1100 V DC

Ambient air temperature is a maximum of 60 °C (140 °F). Cable insulation is rated for a minimum of 90 °C (194 °F).

Use symmetrical cabling with modules connected in parallel. Each module must have the same number of cables with equal cross-section.

The number of cables in the table is for source DC+ connection only. The DC- connection requires the same number of cables.

Table 60: DC/DC Converter Module 640–1100 V DC Source Cable Sizes, IP00/Open Type.

Model code	Frame	Current (I_L) [A]	1-core cable Cu [mm ²]	3-core cable Cu [mm ²]	4-core cable Cu [mm ²]	Max. number of terminals/ bolt size
iC7-60SLDC07-300A	DR10L	300	3x(1x95)	2x(3x70)	1x(4x70)	4 / M10
iC7-60SLDC07-360A		360	3x(1x95)	2x(3x70)	1x(4x70)	
iC7-60SLDC07-420A		420	4x(1x95)	2x(3x95)	1x(4x95)	
iC7-60SLDC07-480A		480	4x(1x95)	2x(3x95)	1x(4x95)	
iC7-60SLDC07-570A		570	4x(1x120)	2x(3x120)	1x(4x120)	
iC7-60SLDC07-720A	DR12L	720	5x(1x95)	3x(3x95)	2x(4x70)	8 / M10
iC7-60SLDC07-840A		840	6x(1x95)	3x(3x95)	2x(4x70)	
iC7-60SLDC07-960A		960	7x(1x95)	3x(3x120)	2x(4x95)	
iC7-60SLDC07-1080		1080	7x(1x95)	3x(3x120)	2x(4x95)	
iC7-60SLDC07-1200		1200	8x(1x95)	4x(3x120)	2x(4x120)	
iC7-60SLDC07-1440	2 x DR12L	1440	10x(1x95)	6x(3x95)	4x(4x70)	16 / M10
iC7-60SLDC07-1680		1680	12x(1x95)	6x(3x95)	4x(4x70)	
iC7-60SLDC07-1920		1920	14x(1x95)	6x(3x120)	4x(4x95)	
iC7-60SLDC07-2160		2160	14x(1x95)	6x(3x120)	4x(4x95)	
iC7-60SLDC07-2400		2400	16x(1x95)	8x(3x120)	4x(4x120)	
iC7-60SLDC07-2880	3 x DR12L	2880	21x(1x95)	9x(3x120)	6x(4x95)	24 / M10
iC7-60SLDC07-3240		3240	21x(1x95)	9x(3x120)	6x(4x95)	
iC7-60SLDC07-3600		3600	24x(1x95)	12x(3x120)	6x(4x120)	
iC7-60SLDC07-3840	4 x DR12L	3840	28x(1x95)	12x(3x120)	8x(4x95)	32 / M10
iC7-60SLDC07-4320		4320	28x(1x95)	12x(3x120)	8x(4x95)	
iC7-60SLDC07-4800		4800	32x(1x95)	16x(3x120)	8x(4x120)	

1) 3-core cables: Use 2 conductors for 'plus' and 'minus', and a third conductor for PE.

2) 4-core cables: Use 2 conductors for 'plus' and 2 conductors for 'minus'.

10.4.11 Marine Cable Sizes for AFE or GC Modules 380–500 V AC

Table 61: Cable Sizes for AFE or GC Module 380-500 V AC for Marine Applications (Marine cables according to IEC 60092-352)

Model code	Frame ⁽¹⁾	I_N [A]	Mains cable Cu [mm ²]	Terminal max. cable size	Number of grounding terminals/ bolt size	Max. number of cables/ bolt size
iC7-60SL3AA5-271A	A_10L	277	2x(3x95)	150 Cu/Al	1/M8	3/M8
iC7-60SL3AA5-317A		324	2x(3x95)	150 Cu/Al	1/M8	3/M8
iC7-60SL3AA5-400A		409	3x(3x95)	150 Cu/Al	1/M8	3/M8
iC7-60SL3AA5-460A		470	3x(3x95)	150 Cu/Al	1/M8	3/M8

Table 61: Cable Sizes for AFE or GC Module 380-500 V AC for Marine Applications (Marine cables according to IEC 60092-352) - (continued)

Model code	Frame ⁽¹⁾	I _N [A]	Mains cable Cu [mm ²]	Terminal max. cable size	Number of grounding terminals/ bolt size	Max. number of cables/ bolt size
iC7-60SL3AA5-520A	A_12L	531	4x(3x95)	150 Cu/Al	1/M8	6/M10
iC7-60SL3AA5-580A		593	4x(3x95)	150 Cu/Al	1/M8	6/M10
iC7-60SL3AA5-650A		664	4x(3x95)	150 Cu/Al	1/M8	6/M10
iC7-60SL3AA5-730A		746	5x(3x95)	150 Cu/Al	1/M8	6/M10
iC7-60SL3AA5-816A		833	5x(3x95)	150 Cu/Al	1/M8	6/M10
iC7-60SL3AA5-970A		991	6x(3x95)	150 Cu/Al	1/M8	6/M10
iC7-60SL3AA5-1040A	2 x A_12L	1062	8x(3x95)	150 Cu/Al	2/M8	12/M10
iC7-60SL3AA5-1210		1236	8x(3x95)	150 Cu/Al	2/M8	12/M10
iC7-60SL3AA5-1300		1328	8x(3x95)	150 Cu/Al	2/M8	12/M10
iC7-60SL3AA5-1410		1440	10x(3x95)	150 Cu/Al	2/M8	12/M10
iC7-60SL3AA5-1630		1664	10x(3x95)	150 Cu/Al	2/M8	12/M10
iC7-60SL3AA5-1900		1940	12x(3x95)	150 Cu/Al	2/M8	12/M10
iC7-60SL3AA5-2080	3 x A_12L	2124	15x(3x95)	150 Cu/Al	3/M8	18/M10
iC7-60SL3AA5-2200		2246	15x(3x95)	150 Cu/Al	3/M8	18/M10
iC7-60SL3AA5-2450		2501	15x(3x95)	150 Cu/Al	3/M8	18/M10
iC7-60SL3AA5-2800		2859	18x(3x95)	150 Cu/Al	3/M8	18/M10
iC7-60SL3AA5-3120	4 x A_12L	3185	20x(3x95)	150 Cu/Al	4/M8	24/M10
iC7-60SL3AA5-3270		3338	20x(3x95)	150 Cu/Al	4/M8	24/M10
iC7-60SL3AA5-3720		3798	24x(3x95)	150 Cu/Al	4/M8	24/M10
iC7-60SL3AA5-4160	5 x A_12L	4247	30x(3x95)	150 Cu/Al	5/M8	30/M10
iC7-60SL3AA5-4650		4747	30x(3x95)	150 Cu/Al	5/M8	30/M10
iC7-60SL3AA5-5200	6 x A_12L	5309	36x(3x95)	150 Cu/Al	6/M8	36/M10
iC7-60SL3AA5-5550		5666	36x(3x95)	150 Cu/Al	6/M8	36/M10
iC7-60SL3AA5-5930	7 x A_12L	6054	42x(3x95)	150 Cu/Al	7/M8	42/M10
iC7-60SL3AA5-6450		6585	42x(3x95)	150 Cu/Al	7/M8	42/M10
iC7-60SL3AA5-6900	8 x A_12L	7044	48x(3x95)	150 Cu/Al	8/M8	48/M10
iC7-60SL3AA5-7370		7524	48x(3x95)	150 Cu/Al	8/M8	48/M10

1) AM10L, AR10L, AM12L, or AR12L

10.4.12 Marine Cable Sizes for AFE or GC Modules 525–690 V AC

[Table 62](#) for cable recommendation is also applicable to the voltage class B5.

Table 62: Cable Sizes for AFE or GC Module 525–690 V AC for Marine Applications (Marine cables according to IEC 60092-352)

Model code	Frame ⁽¹⁾	I _N [A]	Mains cable Cu [mm ²]	Terminal max. cable size	Number of grounding terminals/ bolt size	Max. number of cables/ bolt size
iC7-60SLxx07-236AE00Fx	Ax10L	241	2x(3x70)	150 Cu/Al	1/M8	3/M8
iC7-60SLxxB5-261AE00Fx ⁽²⁾		267	2x(3x95)	150 Cu/Al	1/M8	3/M8
iC7-60SLxx07-300AE00Fx		307	2x(3x95)	150 Cu/Al	1/M8	3/M8
iC7-60SLxxB5-325AE00Fx ⁽²⁾		332	2x(3x95)	150 Cu/Al	1/M8	3/M8
iC7-60SLxx07-334AE00Fx		341	3x(3x70)	150 Cu/Al	1/M8	3/M8
iC7-60SLxx07-380AE00Fx		388	3x(3x95)	150 Cu/Al	1/M8	3/M8
iC7-60SLxx07-425AE00Fx	Ax12L	434	3x(3x95)	150 Cu/Al	1/M8	6/M10
iC7-60SLxx07-475AE00Fx		485	3x(3x95)	150 Cu/Al	1/M8	6/M10
iC7-60SLxx07-530AE00Fx		542	4x(3x95)	150 Cu/Al	1/M8	6/M10
iC7-60SLxx07-595AE00Fx		608	4x(3x95)	150 Cu/Al	1/M8	6/M10
iC7-60SLxx07-670AE00Fx		684	5x(3x95)	150 Cu/Al	1/M8	6/M10
iC7-60SLxx07-760AE00Fx		776	5x(3x95)	150 Cu/Al	1/M8	6/M10
iC7-60SLxx07-850AE00Fx	2 x Ax12L	868	6x(3x95)	150 Cu/Al	2/M8	12/M10
iC7-60SLxx07-945AE00Fx		965	6x(3x95)	150 Cu/Al	2/M8	12/M10
iC7-60SLxx07-1040E00Fx		1062	8x(3x95)	150 Cu/Al	2/M8	12/M10
iC7-60SLxx07-1230E00Fx		1256	8x(3x95)	150 Cu/Al	2/M8	12/M10
iC7-60SLxx07-1325E00Fx		1353	10x(3x95)	150 Cu/Al	2/M8	12/M10
iC7-60SLxx07-1500E00Fx		1532	10x(3x95)	150 Cu/Al	2/M8	12/M10
iC7-60SLxx07-1700E00Fx	3 x Ax12L	1736	12x(3x95)	150 Cu/Al	3/M8	18/M10
iC7-60SLxx07-1800E00Fx		1838	12x(3x95)	150 Cu/Al	3/M8	18/M10
iC7-60SLxx07-2000E00Fx		2042	12x(3x95)	150 Cu/Al	3/M8	18/M10
iC7-60SLxx07-2250E00Fx		2297	12x(3x95)	150 Cu/Al	3/M8	18/M10
iC7-60SLxx07-2500E00Fx	4 x Ax12L	2552	16x(3x95)	150 Cu/Al	4/M8	24/M10
iC7-60SLxx07-2650E00Fx		2706	20x(3x95)	150 Cu/Al	4/M8	24/M10
iC7-60SLxx07-2940E00Fx		3002	20x(3x95)	150 Cu/Al	4/M8	24/M10
iC7-60SLxx07-3120E00Fx	5 x Ax12L	3185	25x(3x95)	150 Cu/Al	5/M8	30/M10
iC7-60SLxx07-3600E00Fx		3675	25x(3x95)	150 Cu/Al	5/M8	30/M10
iC7-60SLxx07-3900E00Fx	6 x Ax12L	3982	30x(3x95)	150 Cu/Al	6/M8	36/M10
iC7-60SLxx07-4320E00Fx		4410	30x(3x95)	150 Cu/Al	6/M8	36/M10
iC7-60SLxx07-4750E00Fx	7 x Ax12L	4849	35x(3x95)	150 Cu/Al	7/M8	42/M10
iC7-60SLxx07-5040E00Fx		5145	35x(3x95)	150 Cu/Al	7/M8	42/M10
iC7-60SLxx07-5400E00Fx	8 x Ax12L	5513	40x(3x95)	150 Cu/Al	8/M8	48/M10
iC7-60SLxx07-5750E00Fx		5870	40x(3x95)	150 Cu/Al	8/M8	48/M10

1) AM10L, AR10L, AM12L, or AR12L

2) Only for B5 voltage class.

10.4.13 Marine Cable Sizes for INU Modules 380–500 V AC

Table 63: Cable Sizes for INU Module 380–500 V AC for Marine Applications (Marine cables according to IEC 60092-352)

Model code	Frame ⁽¹⁾	I _N [A]	Motor cable Cu [mm ²]	Terminal max. cable size	Earth terminal	Max. number of cables/ bolt size
iC7-60SLINA5-206A	I_10L	211	2x(3x70)	150 Cu/Al	1/M8	3/M8
iC7-60SLINA5-245A		251	2x(3x95)	150 Cu/Al	1/M8	3/M8
iC7-60SLINA5-302A		309	2x(3x95)	150 Cu/Al	1/M8	3/M8
iC7-60SLINA5-385A		394	3x(3x95)	150 Cu/Al	1/M8	3/M8
iC7-60SLINA5-480A		490	3x(3x95)	150 Cu/Al	1/M8	3/M8
iC7-60SLINA5-520A		531	3x(3x120)	150 Cu/Al	1/M8	3/M8
iC7-60SLINA5-658A	I_12L	672	5x(3x95)	150 Cu/Al	1/M8	6/M10
iC7-60SLINA5-730A		746	5x(3x95)	150 Cu/Al	1/M8	6/M10
iC7-60SLINA5-820A		838	5x(3x95)	150 Cu/Al	1/M8	6/M10
iC7-60SLINA5-880A		899	6x(3x95)	150 Cu/Al	1/M8	6/M10
iC7-60SLINA5-1000A		1021	6x(3x95)	150 Cu/Al	1/M8	6/M10
iC7-60SLINA5-1270	2 x I_12L	1297	8x(3x95)	150 Cu/Al	2/M8	12/M10
iC7-60SLINA5-1460		1491	10x(3x95)	150 Cu/Al	2/M8	12/M10
iC7-60SLINA5-1630		1664	10x(3x95)	150 Cu/Al	2/M8	12/M10
iC7-60SLINA5-1760		1797	12x(3x95)	150 Cu/Al	2/M8	12/M10
iC7-60SLINA5-1960		2001	12x(3x95)	150 Cu/Al	2/M8	12/M10
iC7-60SLINA5-2130	3 x I_12L	2195	15x(3x95)	150 Cu/Al	3/M8	18/M10
iC7-60SLINA5-2340		2389	15x(3x95)	150 Cu/Al	3/M8	18/M10
iC7-60SLINA5-2510		2563	18x(3x95)	150 Cu/Al	3/M8	18/M10
iC7-60SLINA5-2880		2940	18x(3x95)	150 Cu/Al	3/M8	18/M10
iC7-60SLINA5-3120	4 x I_12L	3185	20x(3x95)	150 Cu/Al	4/M8	24/M10
iC7-60SLINA5-3420		3492	24x(3x95)	150 Cu/Al	4/M8	24/M10
iC7-60SLINA5-3820		3900	24x(3x95)	150 Cu/Al	4/M8	24/M10
iC7-60SLINA5-4140	5 x I_12L	4227	30x(3x95)	150 Cu/Al	5/M8	30/M10
iC7-60SLINA5-4500		4594	30x(3x95)	150 Cu/Al	5/M8	30/M10
iC7-60SLINA5-4750		4849	30x(3x95)	150 Cu/Al	6/M8	30/M10
iC7-60SLINA5-5220	6 x I_12L	5329	36x(3x95)	150 Cu/Al	6/M8	36/M10
iC7-60SLINA5-5680		5799	36x(3x95)	150 Cu/Al	6/M8	36/M10

1) IM10L, IR10L, IM12L, or IR12L

10.4.14 Marine Cable Sizes for INU Modules 525–690 V AC

Table 64 for cable recommendation is also applicable to the voltage class B5.

Table 64: Cable Sizes for INU Module 525–690 V AC for Marine Applications (Marine cables according to IEC 60092-352)

Model code	Frame ⁽¹⁾	I _N [A]	Motor cable Cu [mm ²]	Terminal max. cable size	Earth terminal	Max. number of cables/ bolt size
iC7-60SLIN07-170E00Fx	Ix10L	174	2x(3x70)	150 Cu/Al	1/M8	3/M8
iC7-60SLINB5-206AE00Fx ⁽²⁾		211	2x(3x70)	150 Cu/Al	1/M8	3/M8
iC7-60SLIN07-208AE00Fx		213	2x(3x70)	150 Cu/Al	1/M8	3/M8
iC7-60SLINB5-245AE00Fx ⁽²⁾		251	2x(3x95)	150 Cu/Al	1/M8	3/M8
iC7-60SLIN07-261E00Fx		267	2x(3x95)	150 Cu/Al	1/M8	3/M8
iC7-60SLINB5-302AE00Fx ⁽²⁾		309	2x(3x95)	150 Cu/Al	1/M8	3/M8
iC7-60SLIN07-325E00Fx		332	2x(3x95)	150 Cu/Al	1/M8	3/M8
iC7-60SLIN07-365E00Fx		373	3x(3x95)	150 Cu/Al	1/M8	3/M8
iC7-60SLINB5-385AE00Fx ⁽²⁾		394	3x(3x95)	150 Cu/Al	1/M8	3/M8
iC7-60SLIN07-416E00Fx		425	3x(3x95)	150 Cu/Al	1/M8	3/M8
iC7-60SLIN07-465E00Fx	Ix12L	475	3x(3x95)	150 Cu/Al	1/M8	6/M10
iC7-60SLIN07-525E00Fx		536	4x(3x95)	150 Cu/Al	1/M8	6/M10
iC7-60SLIN07-590E00Fx		603	4x(3x95)	150 Cu/Al	1/M8	6/M10
iC7-60SLIN07-650E00Fx		664	4x(3x95)	150 Cu/Al	1/M8	6/M10
iC7-60SLIN07-730E00Fx		746	5x(3x95)	150 Cu/Al	1/M8	6/M10
iC7-60SLIN07-820E00Fx		838	5x(3x95)	150 Cu/Al	1/M8	6/M10
iC7-60SLIN07-945E00Fx	2 x Ix12L	965	6x(3x95)	150 Cu/Al	2/M8	12/M10
iC7-60SLIN07-1060E00Fx		1083	8x(3x95)	150 Cu/Al	2/M8	12/M10
iC7-60SLIN07-1230E00Fx		1256	8x(3x95)	150 Cu/Al	2/M8	12/M10
iC7-60SLIN07-1400E00Fx		1430	10x(3x95)	150 Cu/Al	2/M8	12/M10
iC7-60SLIN07-1500E00Fx		1532	10x(3x95)	150 Cu/Al	2/M8	12/M10
iC7-60SLIN07-1640E00Fx		1675	10x(3x95)	150 Cu/Al	2/M8	12/M10
iC7-60SLIN07-1795E00Fx	3 x Ix12L	1833	12x(3x95)	150 Cu/Al	3/M8	18/M10
iC7-60SLIN07-2080E00Fx		2124	15x(3x95)	150 Cu/Al	3/M8	18/M10
iC7-60SLIN07-2300E00Fx		2348	15x(3x95)	150 Cu/Al	3/M8	18/M10
iC7-60SLIN07-2460E00Fx		2512	18x(3x95)	150 Cu/Al	3/M8	18/M10
iC7-60SLIN07-2830E00Fx	4 x Ix12L	2889	20x(3x95)	150 Cu/Al	4/M8	24/M10
iC7-60SLIN07-3050E00Fx		3114	20x(3x95)	150 Cu/Al	4/M8	24/M10
iC7-60SLIN07-3260E00Fx		3328	20x(3x95)	150 Cu/Al	4/M8	24/M10
iC7-60SLIN07-3500E00Fx	5 x Ix12L	3573	25x(3x95)	150 Cu/Al	5/M8	30/M10
iC7-60SLIN07-4035E00Fx		4119	25x(3x95)	150 Cu/Al	5/M8	30/M10
iC7-60SLIN07-4400E00Fx	6 x Ix12L	4492	30x(3x95)	150 Cu/Al	6/M8	36/M10
iC7-60SLIN07-4850E00Fx		4951	30x(3x95)	150 Cu/Al	6/M8	36/M10
iC7-60SLIN07-5300E00Fx	7 x Ix12L	5411	35x(3x95)	150 Cu/Al	7/M8	42/M10
iC7-60SLIN07-5600E00Fx		5717	35x(3x95)	150 Cu/Al	7/M8	42/M10

Table 64: Cable Sizes for INU Module 525–690 V AC for Marine Applications (Marine cables according to IEC 60092-352) - (continued)

Model code	Frame ⁽¹⁾	I _N [A]	Motor cable Cu [mm ²]	Terminal max. cable size	Earth terminal	Max. number of cables/ bolt size
iC7-60SLIN07-6100E00Fx	8 x 1x12L	6227	40x(3x95)	150 Cu/Al	8/M8	48/M10
iC7-60SLIN07-6400E00Fx		6534	40x(3x95)	150 Cu/Al	8/M8	48/M10

1) IM10L, IR10L, IM12L, or IR12L

2) Only for B5 voltage class.

10.4.14.1 Cable Sizes for DC-filter Capacitors

For connecting the minus terminal of the DC-filter capacitor to the DC bus, use copper cable or single wire with at least 1100 V DC voltage, and 90 °C (194 °F) temperature rating. See also the iC7 Series Liquid-cooled System Modules Installation Guide.

Minimum cable sizes

- DR10L: 16 mm² (AWG 6)
- DR12L: 35 mm² (AWG 2)

The terminal size is M6.

10.4.15 UL-Rated Cables

10.4.15.1 Mains Cable Sizes for AFE or GC Modules, UL 480 V

Table 65: Mains Cable Sizes for AFE or GC Modules, UL 480 V (Recommendation)

Model code	Frame ⁽¹⁾	I _N [A]	Mains cable Cu [AWG/MCM]	Mains cable termination Panduit terminal part number
iC7-60SL3AA5-271A	A_10L	277	2x3/0	LCAX3/0-12-X
C7-60SL3AA5-317A		324	2x300	LCAX300-12-6
iC7-60SL3AA5-400A		409	2x500	LCAX500-12-6
iC7-60SL3AA5-460A		445	2x500	LCAX500-12-6
iC7-60SL3AA5-520A	A_12L	531	3x300	LCAX300-12-6
iC7-60SL3AA5-580A		593	3x350	LCAX350-12-6
iC7-60SL3AA5-650A		664	4x300	LCAX300-12-6
iC7-60SL3AA5-730A		746	4x300	LCAX300-12-6
iC7-60SL3AA5-816A		833	4x500	LCAX500-12-6
C7-60SL3AA5-970A		940	4x500	LCAX500-12-6
iC7-60SL3AA5-1040	2 x A_12L	1062	6x350	LCAX350-12-6
iC7-60SL3AA5-1210		1236	6x350	LCAX350-12-6
iC7-60SL3AA5-1300		1328	8x300	LCAX300-12-6
iC7-60SL3AA5-1410		1440	8x300	LCAX300-12-6
iC7-60SL3AA5-1630		1664	8x500	LCAX500-12-6
iC7-60SL3AA5-1900		1838	8x500	LCAX500-12-6

Table 65: Mains Cable Sizes for AFE or GC Modules, UL 480 V (Recommendation) - (continued)

Model code	Frame ⁽¹⁾	I _N [A]	Mains cable Cu [AWG/MCM]	Mains cable termination Panduit terminal part number
iC7-60SL3AA5-2080	3 x A_12L	2124	12x300	LCAX300-12-6
iC7-60SL3AA5-2200		2246	12x300	LCAX300-12-6
iC7-60SL3AA5-2450		2501	12x500	LCAX500-12-6
iC7-60SL3AA5-2800		2726	12x500	LCAX500-12-6
iC7-60SL3AA5-3120	4 x A_12L	3185	16x300	LCAX300-12-6
iC7-60SL3AA5-3270		3338	16x350	LCAX350-12-6
iC7-60SL3AA5-3720		3614	16x500	LCAX500-12-6
iC7-60SL3AA5-4160	5 x A_12L	4247	20x500	LCAX500-12-6
iC7-60SL3AA5-4650		4502	20x500	LCAX500-12-6
iC7-60SL3AA5-5200	6 x A_12L	5002	24x350	LCAX350-12-6
iC7-60SL3AA5-5550		5390	24x500	LCAX500-12-6
iC7-60SL3AA5-5930	7 x A_12L	5717	28x350	LCAX350-12-6
iC7-60SL3AA5-6450		6227	28x500	LCAX500-12-6
iC7-60SL3AA5-6900	8 x A_12L	6534	32x350	LCAX350-12-6
iC7-60SL3AA5-7370		7115	32x500	LCAX500-12-6

1) AM10L, AR10L, AM12L, or AR12L.

10.4.15.2 Mains Cable Sizes for AFE or GC Modules, UL 600 V

[Table 66](#) for cable recommendation is also applicable to the voltage class B5.

Table 66: Mains Cable Sizes for AFE or GC Modules, UL 600 V (Recommendation)

Model code	Frame ⁽¹⁾	I _N [A]	Mains cable Cu [AWG/MCM]	Mains cable termination Panduit terminal part number
iC7-60SL3A07-236A	A_10L	241	2x3/0	LCAX3/0-12-X
iC7-60SL3AB5-261A ⁽²⁾		267	2x3/0	LCAX3/0-12-X
iC7-60SL3A07-300A		307	2x4/0	LCAX4/0-12-X
iC7-60SL3AB5-325A ⁽²⁾		332	2x300	LCAX300-12-6
iC7-60SL3A07-334A		341	2x300	LCAX300-12-6
iC7-60SL3A07-380A		388	2x300	LCAX300-12-6
iC7-60SL3A07-425A	A_12L	434	3x4/0	LCAX4/0-12-X
iC7-60SL3A07-475A		485	3x300	LCAX300-12-6
iC7-60SL3A07-530A		542	3x300	LCAX300-12-6
iC7-60SL3A07-595A		608	3x350	LCAX350-12-6
iC7-60SL3A07-670A		684	4x300	LCAX300-12-6
iC7-60SL3A07-760A		776	4x300	LCAX300-12-6

Table 66: Mains Cable Sizes for AFE or GC Modules, UL 600 V (Recommendation) - (continued)

Model code	Frame ⁽¹⁾	I _N [A]	Mains cable Cu [AWG/MCM]	Mains cable termination Panduit terminal part number
iC7-60SL3A07-850A	2 x A_12L	868	6x4/0	LCAX4/0-12-X
iC7-60SL3A07-945A		965	6x4/0	LCAX4/0-12-X
iC7-60SL3A07-1040		1062	6x350	LCAX350-12-6
iC7-60SL3A07-1230		1256	6x350	LCAX350-12-6
iC7-60SL3A07-1325		1353	8x300	LCAX300-12-6
iC7-60SL3A07-1500		1532	8x300	LCAX300-12-6
iC7-60SL3A07-1700	3 x A_12L	1736	12x250	LCAX250-12-X
iC7-60SL3A07-1800		1838	9x350	LCAX350-12-6
iC7-60SL3A07-2000		2042	12x250	LCAX250-12-X
iC7-60SL3A07-2250		2297	12x300	LCAX300-12-6
iC7-60SL3A07-2500	4 x A_12L	2552	16x300	LCAX300-12-6
iC7-60SL3A07-2650		2706	16x300	LCAX300-12-6
iC7-60SL3A07-2940		3002	16x300	LCAX300-12-6
iC7-60SL3A07-3120	5 x A_12L	3185	20x4/0	LCAX4/0-12-X
iC7-60SL3A07-3600		3675	20x300	LCAX300-12-6
iC7-60SL3A07-3900	6 x A_12L	3982	24x250	LCAX250-12-X
iC7-60SL3A07-4320		4410	24x300	LCAX300-12-6
iC7-60SL3A07-4750	7 x A_12L	4849	28x250	LCAX300-12-6
iC7-60SL3A07-5040		5145	28x300	LCAX300-12-6
iC7-60SL3A07-5400	8 x A_12L	5513	32x250	LCAX300-12-6
iC7-60SL3A07-5750		5870	32x300	LCAX300-12-6

1) AM10L, AR10L, AM12L, or AR12L

2) Only for B5 voltage class.

10.4.15.3 Motor Cable Sizes for Inverter Modules, UL 460 V

Table 67: Motor Cable Sizes for Inverter Modules, UL 460 V (Recommendation)

Model code	Frame ⁽¹⁾	I _N [A]	Motor cable Cu [AWG/MCM]	Motor cable termination Panduit terminal part number	Terminal max. cable size	Number of grounding terminals/bolt size	Max. number of cables/bolt size
iC7-60SLINA5-206A	I_10L	211	1x350	LCAX350-12-6	500MCM	1/M8	2/M10
iC7-60SLINA5-245A		251	2x3/0	LCAX3/0-12-X	500MCM	1/M8	2/M10
iC7-60SLINA5-302A		309	2x4/0	LCAX4/0-12-X	500MCM	1/M8	2/M10
iC7-60SLINA5-385A		394	2x300	LCAX300-12-6	500MCM	1/M8	2/M10
iC7-60SLINA5-480A		490	2x500	LCAX500-12-6	500MCM	1/M8	2/M10
iC7-60SLINA5-520A		531	2x500	LCAX500-12-6	500MCM	1/M8	2/M10

Table 67: Motor Cable Sizes for Inverter Modules, UL 460 V (Recommendation) - (continued)

Model code	Frame ⁽¹⁾	I _N [A]	Motor cable Cu [AWG/MCM]	Motor cable termination Panduit terminal part number	Terminal max. cable size	Number of grounding terminals/bolt size	Max. number of cables/bolt size
iC7-60SLINA5-658A	I_12L	672	4x250	LCAX250-12-X	500MCM	1/M8	4/M10
iC7-60SLINA5-730A		746	4x300	LCAX300-12-6	500MCM	1/M8	4/M10
iC7-60SLINA5-820A		838	4x350	LCAX350-12-6	500MCM	1/M8	4/M10
iC7-60SLINA5-880A		899	4x500	LCAX500-12-6	500MCM	1/M8	4/M10
iC7-60SLINA5-1000		970	4x500	LCAX500-12-6	500MCM	1/M8	4/M10
iC7-60SLINA5-1270	2 x I_12L	1297	6x350	LCAX350-12-6	500MCM	2/M8	8/M10
iC7-60SLINA5-1460		1491	8x300	LCAX300-12-6	500MCM	2/M8	8/M10
iC7-60SLINA5-1630		1664	8x350	LCAX350-12-6	500MCM	2/M8	8/M10
iC7-60SLINA5-1760		1797	8x500	LCAX500-12-6	500MCM	2/M8	8/M10
iC7-60SLINA5-1960		1889	8x500	LCAX500-12-6	500MCM	2/M8	8/M10
iC7-60SLINA5-2130	3 x I_12L	2195	12x300	LCAX300-12-6	500MCM	3/M8	12/M10
iC7-60SLINA5-2340		2389	12x300	LCAX300-12-6	500MCM	3/M8	12/M10
iC7-60SLINA5-2510		2563	12x350	LCAX350-12-6	500MCM	3/M8	12/M10
iC7-60SLINA5-2880		2818	12x500	LCAX500-12-6	500MCM	3/M8	12/M10
iC7-60SLINA5-3120	4 x I_12L	3185	16x300	LCAX300-12-6	500MCM	4/M8	16/M10
iC7-60SLINA5-3420		3492	16x350	LCAX350-12-6	500MCM	4/M8	16/M10
iC7-60SLINA5-3820		3726	16x500	LCAX500-12-6	500MCM	4/M8	16/M10
iC7-60SLINA5-4140	5 x I_12L	4024	20x300	LCAX300-12-6	500MCM	5/M8	20/M10
iC7-60SLINA5-4500		4329	20x350	LCAX350-12-6	500MCM	5/M8	20/M10
iC7-60SLINA5-4750		4594	20x500	LCAX500-12-6	500MCM	5/M8	20/M10
iC7-60SLINA5-5220	6 x I_12L	5002	24x350	LCAX350-12-6	500MCM	6/M8	24/M10
iC7-60SLINA5-5680		5462	24x500	LCAX500-12-6	500MCM	6/M8	24/M10

1) IM10L, IR10L, IM12L, or IR12L.

10.4.15.4 Motor Cable Sizes for Inverter Modules, UL 575 V

[Table 68](#) for cable recommendation is also applicable to the voltage class B5.

Table 68: Motor Cable Sizes for Inverter Modules, UL 575 V (Recommendation)

Model code	Frame ⁽¹⁾	I _N [A]	Motor cable Cu [AWG/MCM]	Motor cable termination Panduit terminal part number	Terminal max. cable size	Number of grounding terminals/bolt size	Max. number of cables/bolt size
iC7-60SLIN07-170A	I_10L	174	1x250	LCAX250-12-X	500MCM	1/M8	2/M10
iC7-60SLINB5-206A ⁽²⁾		211	1x350	LCAX350-12-6	500MCM	1/M8	2/M10
iC7-60SLIN07-208A		213	1x350	LCAX350-12-6	500MCM	1/M8	2/M10
iC7-60SLINB5-245A ⁽²⁾		251	2x3/0	LCAX3/0-12-X	500MCM	1/M8	2/M10
iC7-60SLIN07-261A		267	2x3/0	LCAX3/0-12-X	500MCM	1/M8	2/M10
iC7-60SLINB5-302A ⁽²⁾		309	2x4/0	LCAX4/0-12-X	500MCM	1/M8	2/M10
iC7-60SLIN07-325A		332	2x250	LCAX250-12-X	500MCM	1/M8	2/M10
iC7-60SLIN07-365A		373	2x300	LCAX300-12-6	500MCM	1/M8	2/M10
iC7-60SLINB5-385A ⁽²⁾		394	2x300	LCAX300-12-6	500MCM	1/M8	2/M10
iC7-60SLIN07-416A		425	2x350	LCAX350-12-6	500MCM	1/M8	2/M10
iC7-60SLIN07-465A	I_12L	475	3x4/0	LCAX4/0-12-X	500MCM	1/M8	4/M10
iC7-60SLIN07-525A		536	3x250	LCAX250-12-X	500MCM	1/M8	4/M10
iC7-60SLIN07-590A		603	3x350	LCAX350-12-6	500MCM	1/M8	4/M10
iC7-60SLIN07-650A		664	4x250	LCAX250-12-X	500MCM	1/M8	4/M10
iC7-60SLIN07-730A		746	4x300	LCAX300-12-6	500MCM	1/M8	4/M10
iC7-60SLIN07-820A		838	4x350	LCAX350-12-6	500MCM	1/M8	4/M10
iC7-60SLIN07-945A	2 x I_12L	965	6x4/0	LCAX4/0-12-X	500MCM	2/M8	8/M10
iC7-60SLIN07-1060		1083	6x300	LCAX300-12-6	500MCM	2/M8	8/M10
iC7-60SLIN07-1230		1256	6x350	LCAX350-12-6	500MCM	2/M8	8/M10
iC7-60SLIN07-1400		1430	8x250	LCAX250-12-X	500MCM	2/M8	8/M10
iC7-60SLIN07-1500		1532	8x300	LCAX300-12-6	500MCM	2/M8	8/M10
iC7-60SLIN07-1640		1675	8x350	LCAX350-12-6	500MCM	2/M8	8/M10
iC7-60SLIN07-1795	3 x I_12L	1833	9x350	LCAX350-12-6	500MCM	3/M8	12/M10
iC7-60SLIN07-2080		2124	12x250	LCAX250-12-X	500MCM	3/M8	12/M10
iC7-60SLIN07-2300		2348	12x300	LCAX300-12-6	500MCM	3/M8	12/M10
iC7-60SLIN07-2500		2552	12x350	LCAX350-12-6	500MCM	3/M8	12/M10
iC7-60SLIN07-2830	4 x I_12L	2889	16x300	LCAX300-12-6	500MCM	4/M8	16/M10
iC7-60SLIN07-3050		3114	16x300	LCAX300-12-6	500MCM	4/M8	16/M10
iC7-60SLIN07-3260		3328	16x350	LCAX350-12-6	500MCM	4/M8	16/M10
iC7-60SLIN07-3500	5 x I_12L	3573	20x250	LCAX250-12-X	500MCM	5/M8	20/M10
iC7-60SLIN07-4035		4119	20x350	LCAX350-12-6	500MCM	5/M8	20/M10
iC7-60SLIN07-4400	6 x I_12L	4492	24x300	LCAX300-12-6	500MCM	6/M8	24/M10
iC7-60SLIN07-4850		4951	24x350	LCAX350-12-6	500MCM	6/M8	24/M10

Table 68: Motor Cable Sizes for Inverter Modules, UL 575 V (Recommendation) - (continued)

Model code	Frame ⁽¹⁾	I _N [A]	Motor cable Cu [AWG/MCM]	Motor cable termination Panduit terminal part number	Terminal max. cable size	Number of grounding terminals/bolt size	Max. number of cables/bolt size
iC7-60SLIN07-5300	7 x I _L 12L	5411	28x300	LCAX300-12-6	500MCM	7/M8	28/M10
iC7-60SLIN07-5600		5717	28x350	LCAX350-12-6	500MCM	7/M8	28/M10
iC7-60SLIN07-6100	8 x I _L 12L	6227	32x300	LCAX300-12-6	500MCM	8/M8	32/M10
iC7-60SLIN07-6400		6534	32x350	LCAX350-12-6	500MCM	8/M8	32/M10

1) IM10L, IR10L, IM12L, or IR12L

2) Only for B5 voltage class.

10.4.16 Brake Cable Sizes for BCU, 525–690 V AC

Table 69 for cable recommendation is also applicable to the voltage class B5.

Table 69: Brake Cable Sizes for BCU, 525–690 V AC

Model code	Frame	Rated current I _L [A]	Brake cable Cu [mm ²]
iC7-60SLBR07-170A	BM10L	170	3x120+70
iC7-60SLBR07-261A		261	3x185+95
iC7-60SLBR07-416A		416	2x(3x120+70)
iC7-60SLBR07-525A	BM12L	525	2x(3x185+95)
iC7-60SLBR07-650A		650	2x(3x240+120)
iC7-60SLBR07-820A		820	4x(3x120+70)
iC7-60SLBR07-1060	2xBM12L	1060	4x(3x185+95)
iC7-60SLBR07-1400		1400	4x(3x240+120)
iC7-60SLBR07-1640		1640	8x(3x120+70)

10.4.17 Internal DC Cable Sizes for SISO Filters

The cable sizing is based on the following conditions:

- Ambient temperature maximum 60 °C (140 °F).

Use cable insulation that can withstand a temperature of at least 90 °C (194 °F).

Table 70: Internal DC Cable Sizes for SISO Filters

Model code	Frame	Rated DC current I _N [A]	Cable Cu [mm ²]
OF7SI2-M-LC-07-380-A1-E00-Fx	SILC10L	445	2x150
OF7SI2-M-LC-07-760-A1-E00-Fx	SILC12L	888	4x150
OF7SI2-M-LC-07-1500-A1-E00-Fx	SILC14L	1751	8x150
OF7SI4-M-LC-07-380-A1-E00-Fx	SILC10L	445	2x150
OF7SI4-M-LC-07-760-A1-E00-Fx	SILC12L	888	4x150
OF7SI4-M-LC-07-1500-A1-E00-Fx	SILC14L	1751	8x150

Table 70: Internal DC Cable Sizes for SISO Filters - (continued)

Model code	Frame	Rated DC current I_N [A]	Cable Cu [mm ²]
OF7S02-M-LC-07-730-A1-E00-F4	SOSIN12L	836	4x150
OF7S02-M-LC-07-1400-A1-E00-F4	SOSIN14L	1530	8x150

10.5 Fuses

10.5.1 General Information on the Fuse Tables

The fuse size tables for the liquid-cooled system modules can be found with these links. The time-current curves of the fuses can be applied for both AC and DC current in selectivity analysis even if the fuses are designated as AC fuses. Drives are protected with high speed aR fuses.

NOTICE

FUSES FROM DIFFERENT MANUFACTURERS

Mixing fuses from different manufacturers can damage the equipment.

- Use fuses from only one manufacturer in the system.

- [10.5.2 AC Fuses for AFE or GC 380–500 V AC, IP00/Open Type](#)
- [10.5.3 AC Fuses for AFE or GC 525–690 V AC, IP00/Open Type](#)
- [10.5.4 DC Fuses for AFE or GC 450–830 V DC, IP00/Open Type](#)
- [10.5.5 DC Fuses for AFE or GC 640–1100 V DC, IP00/Open Type](#)
- [10.5.6 AC Fuses for GC 380–690 V AC, Voltage Class G7, IP00/Open Type](#)
- [10.5.7 DC Fuses for GC 380–690 V AC \(500–1500 V DC\), Voltage Class G7, IP00/Open Type](#)
- [10.5.8 DC Fuses for INU 450–830 V DC, IP00/Open Type](#)
- [10.5.9 DC Fuses for INU 640–1100 V DC, IP00/Open Type](#)
- [10.5.10 AC Fuses for INU, IP00/Open Type in Generator Use](#)
- [10.5.11 DC-bus Fuses for DC/DC Converter, IP00/Open Type](#)
- [10.5.12 Source DC+ Fuses for DC/DC Converter, IP00/Open Type](#)
- [10.5.13 Source DC- Fuses for DC/DC Converter, IP00/Open Type](#)
- [10.5.14 DC Fuses for BCU, Voltage Class B5 and 07, IP00/Open Type](#)
- [10.5.15 AC Fuses and Circuit Breakers for L Filter, Voltage Class A5](#)
- [10.5.16 AC Fuses and Circuit Breakers for L Filter, Voltage Class B5 and 07](#)
- [10.5.17 AC Fuses and Circuit Breakers for L Filter, Voltage Class G7](#)
- [10.5.18 DC Fuses for SISO Filters 640–1100 V DC, IP00/Open Type](#)

Table 71: Abbreviations Used in the Fuse Tables

Abbreviation	Description
$I_{cp, mr}$	Minimum required prospective short-circuit current at 5 ms pre-arcing time. For parallel modules, the short-circuit current of a single module is sufficient.
I_L	Nominal current of the drive with low overload (110%). Allows a +10% load variation for 1 minute every 5 minutes.

Table 71: Abbreviations Used in the Fuse Tables - (continued)

Abbreviation	Description
I_N	Nominal current of the fuse.
U_N	Nominal voltage of the fuse.

10.5.2 AC Fuses for AFE or GC 380–500 V AC, IP00/Open Type

Table 72: AC Fuses for AFE or GC 380–500 V AC, IP00/Open Type, Ax10L (Mersen)

Model code ⁽¹⁾	Frame	Rated current I_L [A]	Number of fuses	Fuse size	Part number	Fuse U_n [V]	Fuse I_n [A]	$I_{cp, mr}$ [A]
iC7-60SLxxA5-271AE00Fx	Ax10L	271	6	31	PC31UD69V315TF	690	315	3600
iC7-60SLxxA5-317AE00Fx		317						
iC7-60SLxxA5-400AE00Fx	Ax10L	400	6	31	PC31UD69V450TF	690	450	6700
iC7-60SLxxA5-460AE00Fx		460						

1) For example, iC7-60SL3AA5-236AE00F4

Table 73: AC Fuses for AFE or GC 380–500 V AC, IP00/Open Type, Ax12L (Mersen)

Model code ⁽¹⁾	Frame	Rated current I_L [A]	Number of fuses	Fuse size	Part number	Fuse U_n [V]	Fuse I_n [A]	$I_{cp, mr}$ [A]				
iC7-60SLxxA5-520AE00Fx	Ax12L	520	3	44	PC44UD75V12CTQ	750	1200	7200				
iC7-60SLxxA5-580AE00Fx		580										
iC7-60SLxxA5-650AE00Fx		650										
iC7-60SLxxA5-730AE00Fx		730										
iC7-60SLxxA5-816AE00Fx		816							PC44UD75V16CTQ	750	1600	11700
iC7-60SLxxA5-970AE00Fx		970										
iC7-60SLxxA5-1040E00Fx	2xAx12L	1040	6	44	PC44UD75V12CTQ	750	1200	–				
iC7-60SLxxA5-1210E00Fx		1210										
iC7-60SLxxA5-1300E00Fx		1300										
iC7-60SLxxA5-1410E00Fx		1410										
iC7-60SLxxA5-1630E00Fx		1630							PC44UD75V16CTQ	750	1600	–
iC7-60SLxxA5-1900E00Fx		1900										
iC7-60SLxxA5-2080E00Fx	3xAx12L	2080	9	44	PC44UD75V12CTQ	750	1200	–				
iC7-60SLxxA5-2200E00Fx		2200										
iC7-60SLxxA5-2450E00Fx		2450							PC44UD75V16CTQ	750	1600	–
iC7-60SLxxA5-2800E00Fx		2800										
iC7-60SLxxA5-3120E00Fx	4xAx12L	3120	12	44	PC44UD75V12CTQ	750	1200	–				
iC7-60SLxxA5-3270E00Fx		3270							PC44UD75V16CTQ	750	1600	–
iC7-60SLxxA5-3720E00Fx		3720										

Table 73: AC Fuses for AFE or GC 380–500 V AC, IP00/Open Type, Ax12L (Mersen) - (continued)

Model code ⁽¹⁾	Frame	Rated current I_L [A]	Number of fuses	Fuse size	Part number	Fuse U_n [V]	Fuse I_n [A]	$I_{cp, mr}$ [A]
iC7-60SLxxA5-4160E00Fx	5xAx12L	4160	15	44	PC44UD75V16CTQ	750	1600	–
iC7-60SLxxA5-4650E00Fx		4650						
iC7-60SLxxA5-5200E00Fx	6xAx12L	5200	18	44	PC44UD75V16CTQ	750	1600	–
iC7-60SLxxA5-5550E00Fx		5550						
iC7-60SLxxA5-5930E00Fx	7xAx12L	5930	21	44	PC44UD75V16CTQ	750	1600	–
iC7-60SLxxA5-6550E00Fx		6450						
iC7-60SLxxA5-6900E00Fx	8xAx12L	6900	24	44	PC44UD75V16CTQ	750	1600	–
iC7-60SLxxA5-7370E00Fx		7370						

1) For example, iC7-60SL3AA5-520AE00F4

Table 74: AC Fuses for AFE or GC 380–500 V AC, IP00/Open Type, Ax10L (Eaton/Bussmann)

Model code ⁽¹⁾	Frame	Rated current I_L [A]	Number of fuses	Fuse size	Part number	Fuse U_n [V]	Fuse I_n [A]	$I_{cp, mr}$ [A]
iC7-60SLxxA5-271AE00Fx	Ax10L	271	6	1	170M4411	690	350	3800
iC7-60SLxxA5-317AE00Fx		317						
iC7-60SLxxA5-400AE00Fx	Ax10L	400	6	1	170M4414	690	500	6500
iC7-60SLxxA5-460AE00Fx		460						

1) For example, iC7-60SL3AA5-236AE00F4

Table 75: AC Fuses for AFE or GC 380–500 V AC, IP00/Open Type, Ax12L (Eaton/Bussmann)

Model code ⁽¹⁾	Frame	Rated current I_L [A]	Number of fuses	Fuse size	Part number	Fuse U_n [V]	Fuse I_n [A]	$I_{cp, mr}$ [A]
iC7-60SLxxA5-520AE00Fx	Ax12L	520	3	4	170M7348	690	1250	6300
iC7-60SLxxA5-580AE00Fx		580						
iC7-60SLxxA5-650AE00Fx		650						
iC7-60SLxxA5-730AE00Fx		730						
iC7-60SLxxA5-816AE00Fx		816						
iC7-60SLxxA5-970AE00Fx		970						
iC7-60SLxxA5-1040E00Fx	2xAx12L	1040	6	4	170M7348	690	1250	–
iC7-60SLxxA5-1210E00Fx		1210						
iC7-60SLxxA5-1300E00Fx		1300						
iC7-60SLxxA5-1410E00Fx		1410						
iC7-60SLxxA5-1630E00Fx		1630						
iC7-60SLxxA5-1900E00Fx		1900						
					170M7349	690	1800	13100
					170M7349	690	1800	–

Table 75: AC Fuses for AFE or GC 380–500 V AC, IP00/Open Type, Ax12L (Eaton/Bussmann) - (continued)

Model code ⁽¹⁾	Frame	Rated current I_L [A]	Number of fuses	Fuse size	Part number	Fuse U_n [V]	Fuse I_n [A]	$I_{cp, mr}$ [A]
iC7-60SLxxA5-2080E00Fx	3xAx12L	2080	9	4	170M7348	690	1250	–
iC7-60SLxxA5-2200E00Fx		2200						
iC7-60SLxxA5-2450E00Fx		2450			170M7349			
iC7-60SLxxA5-2800E00Fx		2800						
iC7-60SLxxA5-3120E00Fx	4xAx12L	3120	12	4	170M7348	690	1250	–
iC7-60SLxxA5-3270E00Fx		3270			170M7349			
iC7-60SLxxA5-3720E00Fx		3720						
iC7-60SLxxA5-4160E00Fx	5xAx12L	4160	15	4	170M7349	690	1800	–
iC7-60SLxxA5-4650E00Fx		4650						
iC7-60SLxxA5-5200E00Fx	6xAx12L	5200	18	4	170M7349	690	1800	–
iC7-60SLxxA5-5550E00Fx		5550						
iC7-60SLxxA5-5930E00Fx	7xAx12L	5930	21	4	170M7349	690	1800	–
iC7-60SLxxA5-6550E00Fx		6450						
iC7-60SLxxA5-6900E00Fx	8xAx12L	6900	24	4	170M7349	690	1800	–
iC7-60SLxxA5-7370E00Fx		7370						

1) For example, iC7-60SL3AA5-520AE00F4

10.5.3 AC Fuses for AFE or GC 525–690 V AC, IP00/Open Type

Table 76 for fuse recommendation is also applicable to the voltage class B5.

Table 76: AC Fuses for AFE or GC 525–690 V AC, IP00/Open Type, Ax10L (Mersen)

Model code ⁽¹⁾	Frame	Rated current I_L [A]	Number of fuses	Fuse size	Part number	Fuse U_n [V]	Fuse I_n [A]	$I_{cp, mr}$ [A]
iC7-60SLxx07-236AE00Fx	Ax10L	236	6	31	PC31UD69V250TF	690	250	2900
iC7-60SLxxB5-261AE00Fx ⁽²⁾		261						
iC7-60SLxx07-300AE00Fx		300						
iC7-60SLxxB5-325AE00Fx ⁽²⁾	Ax10L	325	6	31	PC31UD69V315TF	690	315	3600
iC7-60SLxx07-334AE00Fx		334						
iC7-60SLxx07-380AE00Fx		380						

1) For example, iC7-60SL3A07-236AE00F4

2) Only for B5 voltage class

Table 77: AC Fuses for AFE or GC 525–690 V AC, IP00/Open Type, Ax12L (Mersen)

Model code ⁽¹⁾	Frame	Rated current I_L [A]	Number of fuses	Fuse size	Part number	Fuse U_n [V]	Fuse I_n [A]	$I_{cp, mr}$ [A]
iC7-60SLxx07-425AE00Fx	Ax12L	425	3	44	PC44UD75V12CTQ	750	1200	7200
iC7-60SLxx07-475AE00Fx		475						
iC7-60SLxx07-530AE00Fx		530						
iC7-60SLxx07-595AE00Fx		595						
iC7-60SLxx07-670AE00Fx		670						
iC7-60SLxx07-760AE00Fx		760						
iC7-60SLxx07-850AE00Fx	2 x Ax12L	850	6	44	PC44UD75V12CTQ	750	1200	–
iC7-60SLxx07-945AE00Fx		945						
iC7-60SLxx07-1040E00Fx		1040						
iC7-60SLxx07-1230E00Fx		1230						
iC7-60SLxx07-1325E00Fx		1325						
iC7-60SLxx07-1500E00Fx		1500						
iC7-60SLxx07-1700E00Fx	3 x Ax12L	1700	9	44	PC44UD75V12CTQ	750	1200	–
iC7-60SLxx07-1800E00Fx		1800						
iC7-60SLxx07-2000E00Fx		2000						
iC7-60SLxx07-2250E00Fx		2250						
iC7-60SLxx07-2500E00Fx	4 x Ax12L	2500	12	44	PC44UD75V12CTQ	750	1200	–
iC7-60SLxx07-2650E00Fx		2650						
iC7-60SLxx07-2940E00Fx		2940						
iC7-60SLxx07-3120E00Fx	5 x Ax12L	3120	15	44	PC44UD75V12CTQ	750	1200	–
iC7-60SLxx07-3600E00Fx		3600						
iC7-60SLxx07-3900E00Fx	6 x Ax12L	3900	18	44	PC44UD75V12CTQ	750	1200	–
iC7-60SLxx07-4320E00Fx		4320						
iC7-60SLxx07-4750E00Fx	7 x Ax12L	4750	21	44	PC44UD75V12CTQ	750	1200	–
iC7-60SLxx07-5040E00Fx		5040						
iC7-60SLxx07-5400E00Fx	8 x Ax12L	5400	24	44	PC44UD75V12CTQ	750	1200	–
iC7-60SLxx07-5750E00Fx		5750						

1) For example, iC7-60SL3A07-425AE00F4

Table 78 for fuse recommendation is also applicable to the voltage class B5.

Table 78: AC Fuses for AFE or GC 525–690 V AC, IP00/Open Type, Ax10L (Eaton/Bussmann)

Model code ⁽¹⁾	Frame	Rated current I_L [A]	Number of fuses	Fuse size	Part number	Fuse U_n [V]	Fuse I_n [A]	$I_{cp, mr}$ [A]
iC7-60SLxx07-236AE00Fx	Ax10L	236	6	1	170M4410	690	315	3300
iC7-60SLxxB5-261AE00Fx ⁽²⁾		261						
iC7-60SLxx07-300AE00Fx		300						
iC7-60SLxxB5-325AE00Fx ⁽²⁾	Ax10L	325	6	1	170M4411	690	350	3900
iC7-60SLxx07-334AE00Fx		334						
iC7-60SLxx07-380AE00Fx		380						

1) For example, iC7-60SL3A07-236AE00F4

2) Only for B5 voltage class

Table 79: AC Fuses for AFE or GC 525–690 V AC, IP00/Open Type, Ax12L (Eaton/Bussmann)

Model code ⁽¹⁾	Frame	Rated current I_L (A)	Number of fuses	Fuse size	Part number	Fuse U_n [V]	Fuse I_n [A]	$I_{cp, mr}$ [A]
iC7-60SLxx07-425AE00Fx	Ax12L	425	3	4	170M7348	690	1250	6600
iC7-60SLxx07-475AE00Fx		475						
iC7-60SLxx07-530AE00Fx		530						
iC7-60SLxx07-595AE00Fx		595						
iC7-60SLxx07-670AE00Fx		670						
iC7-60SLxx07-760AE00Fx		760						
iC7-60SLxx07-850AE00Fx	2 x Ax12L	850	6	4	170M7348	690	1250	–
iC7-60SLxx07-945AE00Fx		945						
iC7-60SLxx07-1040E00Fx		1040						
iC7-60SLxx07-1230E00Fx		1230						
iC7-60SLxx07-1325E00Fx		1325						
iC7-60SLxx07-1500E00Fx		1500						
iC7-60SLxx07-1700E00Fx	3 x Ax12L	1700	9	4	170M7348	690	1250	–
iC7-60SLxx07-1800E00Fx		1800						
iC7-60SLxx07-2000E00Fx		2000						
iC7-60SLxx07-2250E00Fx		2250						
iC7-60SLxx07-2500E00Fx	4 x Ax12L	2500	12	4	170M7348	690	1250	–
iC7-60SLxx07-2650E00Fx		2650						
iC7-60SLxx07-2940E00Fx		2940						
iC7-60SLxx07-3120E00Fx	5 x Ax12L	3120	15	4	170M7348	690	1250	–
iC7-60SLxx07-3600E00Fx		3600						
iC7-60SLxx07-3900E00Fx	6 x Ax12L	3900	18	4	170M7348	690	1250	–
iC7-60SLxx07-4320E00Fx		4320						

Table 79: AC Fuses for AFE or GC 525–690 V AC, IP00/Open Type, Ax12L (Eaton/Bussmann) - (continued)

Model code ⁽¹⁾	Frame	Rated current I_L (A)	Number of fuses	Fuse size	Part number	Fuse U_n [V]	Fuse I_n [A]	$I_{cp, mr}$ [A]
iC7-60SLxx07-4750E00Fx	7 x Ax12L	4750	21	4	170M7348	690	1250	–
iC7-60SLxx07-5040E00Fx		5040						
iC7-60SLxx07-5400E00Fx	8 x Ax12L	5400	24	4	170M7348	690	1250	–
iC7-60SLxx07-5750E00Fx		5750						

1) For example, iC7-60SL3A07-425AE00F4

10.5.4 DC Fuses for AFE or GC 450–830 V DC, IP00/Open Type

Table 80: DC Fuses for AFE or GC 450–830 V DC, IP00/Open Type (Mersen)

Model code ⁽¹⁾	Frame	Rated current I_L [A]	Number of fuses	Fuse size	Part number	Fuse U_n [V]	Fuse I_n [A]
iC7-60SLxxA5-271AE00Fx	Ax10L	271	2	73	PC73UD13C800TF	1250	800
iC7-60SLxxA5-317AE00Fx		317			PC73UD12C900TF	1200	900
iC7-60SLxxA5-400AE00Fx		400			PC73UD95V11CTF	950	1100
iC7-60SLxxA5-460AE00Fx		460					
iC7-60SLxxA5-520AE00Fx	Ax12L	520	4	73	PC73UD13C800TF	1250	800
iC7-60SLxxA5-580AE00Fx		580					
iC7-60SLxxA5-650AE00Fx		650			PC73UD12C900TF	1200	900
iC7-60SLxxA5-730AE00Fx		730					
iC7-60SLxxA5-816AE00Fx		816			PC73UD95V11CTF	950	1100
iC7-60SLxxA5-970AE00Fx		970					
iC7-60SLxxA5-1040E00Fx	2xAx12L	1040	8	73	PC73UD13C800TF	1250	800
iC7-60SLxxA5-1210E00Fx		1210					
iC7-60SLxxA5-1300E00Fx		1300			PC73UD12C900TF	1200	900
iC7-60SLxxA5-1410E00Fx		1410					
iC7-60SLxxA5-1630E00Fx		1630			PC73UD95V11CTF	950	1100
iC7-60SLxxA5-1900E00Fx		1900					
iC7-60SLxxA5-2080E00Fx	3xAx12L	2080	12	73	PC73UD12C900TF	1200	900
iC7-60SLxxA5-2200E00Fx		2200					
iC7-60SLxxA5-2450E00Fx		2450			PC73UD95V11CTF	950	1100
iC7-60SLxxA5-2800E00Fx		2800					
iC7-60SLxxA5-3120E00Fx	4xAx12L	3120	16	73	PC73UD12C900TF	1200	900
iC7-60SLxxA5-3270E00Fx		3270			PC73UD95V11CTF	950	1100
iC7-60SLxxA5-3720E00Fx		3720					
iC7-60SLxxA5-4160E00Fx	5xAx12L	4160	20	73	PC73UD12C900TF	1200	900
iC7-60SLxxA5-4650E00Fx		4650			PC73UD95V11CTF	950	1100

Table 80: DC Fuses for AFE or GC 450–830 V DC, IP00/Open Type (Mersen) - (continued)

Model code ⁽¹⁾	Frame	Rated current I_L [A]	Number of fuses	Fuse size	Part number	Fuse U_n [V]	Fuse I_n [A]
iC7-60SLxxA5-5200E00Fx	6xAx12L	5200	24	73	PC73UD95V11CTF	950	1100
iC7-60SLxxA5-5550E00Fx		5550					
iC7-60SLxxA5-5930E00Fx	7xAx12L	5930	28	73	PC73UD95V11CTF	950	1100
iC7-60SLxxA5-6550E00Fx		6450					
iC7-60SLxxA5-6900E00Fx	8xAx12L	6900	32	73	PC73UD95V11CTF	950	1100
iC7-60SLxxA5-7370E00Fx		7370					

1) For example, iC7-60SL3AA5-271AE00F4

Table 81: DC Fuses for AFE or GC 450–830 V DC, IP00/Open Type (Eaton/Bussmann)

Model code ⁽¹⁾	Frame	Rated current I_L [A]	Number of fuses	Fuse size	Part number	Fuse U_n [V]	Fuse I_n [A]
iC7-60SLxxA5-271AE00Fx	Ax10L	271	2	3	180D6347	900	900
iC7-60SLxxA5-317AE00Fx		317			180D6349	900	1100
iC7-60SLxxA5-400AE00Fx		400			180D8583	500	1400
iC7-60SLxxA5-460AE00Fx		460					
iC7-60SLxxA5-520AE00Fx	Ax12L	520	4	3	180D6347	900	900
iC7-60SLxxA5-580AE00Fx		580					
iC7-60SLxxA5-650AE00Fx		650			180D6349	900	1100
iC7-60SLxxA5-730AE00Fx		730					
iC7-60SLxxA5-816AE00Fx		816			180D8583	500	1400
iC7-60SLxxA5-970AE00Fx		970					
iC7-60SLxxA5-1040E00Fx	2xAx12L	1040	8	3	180D6347	900	900
iC7-60SLxxA5-1210E00Fx		1210					
iC7-60SLxxA5-1300E00Fx		1300			180D6349	900	1100
iC7-60SLxxA5-1410E00Fx		1410					
iC7-60SLxxA5-1630E00Fx		1630			180D8583	500	1400
iC7-60SLxxA5-1900E00Fx		1900					
iC7-60SLxxA5-2080E00Fx	3xAx12L	2080	12	3	180D6349	900	1100
iC7-60SLxxA5-2200E00Fx		2200					
iC7-60SLxxA5-2450E00Fx		2450			180D8583	500	1400
iC7-60SLxxA5-2800E00Fx		2800					
iC7-60SLxxA5-3120E00Fx	4xAx12L	3120	16	3	180D6349	900	1100
iC7-60SLxxA5-3270E00Fx		3270			180D8583	500	1400
iC7-60SLxxA5-3720E00Fx		3720					

Table 81: DC Fuses for AFE or GC 450–830 V DC, IP00/Open Type (Eaton/Bussmann) - (continued)

Model code ⁽¹⁾	Frame	Rated current I_L [A]	Number of fuses	Fuse size	Part number	Fuse U_n [V]	Fuse I_n [A]
iC7-60SLxxA5-4160E00Fx	5xAx12L	4160	20	3	180D6349	900	1100
iC7-60SLxxA5-4650E00Fx		4650			180D8583	500	1400
iC7-60SLxxA5-5200E00Fx	6xAx12L	5200	24	3	180D8583	500	1400
iC7-60SLxxA5-5550E00Fx		5550					
iC7-60SLxxA5-5930E00Fx	7xAx12L	5930	28	3	180D8583	500	1400
iC7-60SLxxA5-6550E00Fx		6450					
iC7-60SLxxA5-6900E00Fx	8xAx12L	6900	32	3	180D8583	500	1400
iC7-60SLxxA5-7370E00Fx		7370					

1) For example, iC7-60SL3AA5-271AE00F4

10.5.5 DC Fuses for AFE or GC 640–1100 V DC, IP00/Open Type

Table 82 for fuse recommendation is also applicable to the voltage class B5.

Table 82: DC Fuses for AFE or GC 640–1100 V DC, IP00/Open Type (Mersen)

Model code ⁽¹⁾	Frame	Rated current I_L [A]	Number of fuses	Fuse size	Part number	Fuse U_n [V]	Fuse I_n [A]
iC7-60SL3A07-236AE00Fx	Ax10L	236	2	73	PC73UD13C800TF	1250	800
iC7-60SL3AB5-261AE00Fx ⁽²⁾		261					
iC7-60SL3A07-300AE00Fx		300					
iC7-60SL3AB5-325AE00Fx ⁽²⁾		325			PC73UD12C900TF	1200	900
iC7-60SL3A07-334AE00Fx		334					
iC7-60SL3A07-380AE00Fx		380					
iC7-60SL3A07-425AE00Fx	Ax12L	425	4	73	PC73UD13C800TF	1250	800
iC7-60SL3A07-475AE00Fx		475					
iC7-60SL3A07-530AE00Fx		530					
iC7-60SL3A07-595AE00Fx		595			PC73UD12C900TF	1200	900
iC7-60SL3A07-670AE00Fx		670					
iC7-60SL3A07-760AE00Fx		760					
iC7-60SL3A07-850AE00Fx	2 x Ax12L	850	8	73	PC73UD13C800TF	1250	800
iC7-60SL3A07-945AE00Fx		945					
iC7-60SL3A07-1040E00Fx		1040					
iC7-60SL3A07-1230E00Fx		1230					
iC7-60SL3A07-1325E00Fx		1325					
iC7-60SL3A07-1500E00Fx		1500					

Table 82: DC Fuses for AFE or GC 640–1100 V DC, IP00/Open Type (Mersen) - (continued)

Model code ⁽¹⁾	Frame	Rated current I_L [A]	Number of fuses	Fuse size	Part number	Fuse U_n [V]	Fuse I_n [A]
iC7-60SL3A07-1700E00Fx	3 x Ax12L	1700	12	73	PC73UD13C800TF	1250	800
iC7-60SL3A07-1800E00Fx		1800			PC73UD12C900TF	1200	900
iC7-60SL3A07-2000E00Fx		2000					
iC7-60SL3A07-2250E00Fx		2250					
iC7-60SL3A07-2500E00Fx	4 x Ax12L	2500	16	73	PC73UD12C900TF	1200	900
iC7-60SL3A07-2650E00Fx		2650					
iC7-60SL3A07-2940E00Fx		2940					
iC7-60SL3A07-3120E00Fx	5 x Ax12L	3120	20	73	PC73UD12C900TF	1200	900
iC7-60SL3A07-3600E00Fx		3600					
iC7-60SL3A07-3900E00Fx	6 x Ax12L	3900	24	73	PC73UD12C900TF	1200	900
iC7-60SL3A07-4320E00Fx		4320					
iC7-60SL3A07-4750E00Fx	7 x Ax12L	4750	28	73	PC73UD12C900TF	1200	900
iC7-60SL3A07-5040E00Fx		5040					
iC7-60SL3A07-5400E00Fx	8 x Ax12L	5400	32	73	PC73UD12C900TF	1200	900
iC7-60SL3A07-5750E00Fx		5750					

1) For example, iC7-60SL3A07-236AE00F4

2) Only for B5 voltage class.

Table 83 for fuse recommendation is also applicable to the voltage class B5.

Table 83: DC Fuses for AFE or GC 640–1100 V DC, IP00/Open Type (Eaton/Bussmann)

Model code ⁽¹⁾	Frame	Rated current I_L [A]	Number of fuses	Fuse size	Part number	Fuse U_n [V]	Fuse I_n [A]
iC7-60SLxx07-236AE00Fx	A_10L	236	2	3	180D6347	900	900
C7-60SLxxB5-261AE00Fx ⁽²⁾		261					
iC7-60SLxx07-300AE00Fx		300					
iC7-60SLxxB5-325AE00Fx ⁽²⁾		325			180D6349	900	1100
iC7-60SLxx07-334AE00Fx		334					
iC7-60SLxx07-380AE00Fx		380					
iC7-60SLxx07-425AE00Fx	A_12L	425	4	3	180D6347	900	900
iC7-60SLxx07-475AE00Fx		475					
iC7-60SLxx07-530AE00Fx		530					
C7-60SLxx07-595AE00Fx		595			180D6349	900	1100
iC7-60SLxx07-670AE00Fx		670					
C7-60SLxx07-760AE00Fx		760					

Table 83: DC Fuses for AFE or GC 640–1100 V DC, IP00/Open Type (Eaton/Bussmann) - (continued)

Model code ⁽¹⁾	Frame	Rated current I_L [A]	Number of fuses	Fuse size	Part number	Fuse U_n [V]	Fuse I_n [A]
iC7-60SLxx07-850AE00Fx	2 x A_12L	850	8	3	180D6347	900	900
iC7-60SLxx07-945AE00Fx		945					
iC7-60SLxx07-1040E00Fx		1040					
iC7-60SLxx07-1230E00Fx		180D6349			1230	900	1100
iC7-60SLxx07-1325E00Fx					1325		
iC7-60SLxx07-1500E00Fx					1500		
iC7-60SLxx07-1700E00Fx	3 x A_12L	1700	12	3	180D6347	900	900
iC7-60SLxx07-1800E00Fx		1800			180D6349	900	1100
iC7-60SLxx07-2000E00Fx		2000					
iC7-60SLxx07-2250E00Fx		2250					
iC7-60SLxx07-2500E00Fx	4 x A_12L	2500	16	3	180D6349	900	1100
iC7-60SLxx07-2650E00Fx		2650					
iC7-60SLxx07-2940E00Fx		2940					
iC7-60SLxx07-3120E00Fx	5 x A_12L	3120	20	3	180D6349	900	1100
iC7-60SLxx07-3600E00Fx		3600					
iC7-60SLxx07-3900E00Fx	6 x A_12L	3900	24	3	180D6349	900	1100
iC7-60SLxx07-4320E00Fx		4320					
iC7-60SLxx07-4750E00Fx	7 x A_12L	4750	28	3	180D6349	900	1100
iC7-60SLxx07-5040E00Fx		5040					
iC7-60SLxx07-5400E00Fx	8 x A_12L	5400	32	3	180D6349	900	1100
iC7-60SLxx07-5750E00Fx		5750					

1) For example, iC7-60SL3A07-236AE00F4

2) Only for B5 voltage class.

10.5.6 AC Fuses for GC 380–690 V AC, Voltage Class G7, IP00/Open Type

Table 84: AC Fuses for GC 380–690 V AC, Voltage Class G7, IP00/Open Type

Model code	Frame	Rated current I_L [A]	Number of fuses	Fuse size	Part number	Fuse U_n [V]	Fuse I_n [A]	$I_{cp,mr}$ [A]
iC7-60SLGCG7-760A	AR12L	760	3	44	PC44UD75V12CTQ	750	1200	7200
iC7-60SLGCG7-970A	AR12L	970	3	44	PC44UD75V16CTQ	750	1600	11700
iC7-60SLGCG7-1500	2 x AR12L	1500	6	44	PC44UD75V12CTQ	750	1200	7200
iC7-60SLGCG7-1700	2 x AR12L	1700	6	44	PC44UD75V16CTQ	750	1600	11700
iC7-60SLGCG7-1900	2 x AR12L	1900	6	44	PC44UD75V16CTQ	750	1600	11700
iC7-60SLGCG7-2450	3 x AR12L	2450	9	44	PC44UD75V12CTQ	750	1200	7200
iC7-60SLGCG7-2800	3 x AR12L	2800	9	44	PC44UD75V16CTQ	750	1600	11700

Table 84: AC Fuses for GC 380–690 V AC, Voltage Class G7, IP00/Open Type - (continued)

Model code	Frame	Rated current I_L [A]	Number of fuses	Fuse size	Part number	Fuse U_n [V]	Fuse I_n [A]	$I_{cp,mr}$ [A]
iC7-60SLGCG7-3270	4 x AR12L	3270	12	44	PC44UD75V12CTQ	750	1200	7200
iC7-60SLGCG7-3720	4 x AR12L	3720	12	44	PC44UD75V16CTQ	750	1600	11700
iC7-60SLGCG7-4160	5 x AR12L	4160	15	44	PC44UD75V12CTQ	750	1200	7200
iC7-60SLGCG7-4650	5 x AR12L	4650	15	44	PC44UD75V16CTQ	750	1600	11700
iC7-60SLGCG7-5550	6 x AR12L	5550	18	44	PC44UD75V16CTQ	750	1600	11700
iC7-60SLGCG7-6450	7 x AR12L	6450	21	44	PC44UD75V16CTQ	750	1600	11700
iC7-60SLGCG7-7370	8 x AR12L	7370	24	44	PC44UD75V16CTQ	750	1600	11700

10.5.7 DC Fuses for GC 380–690 V AC (500–1500 V DC), Voltage Class G7, IP00/Open Type

Table 85: DC Fuses for GC 380–690 V AC (500–1500 V DC), Voltage Class G7, IP00/Open Type

Model code	Frame	Rated current I_L [A]	Number of fuses	Fuse size	Part number	Fuse U_n [V]	Fuse I_n [A]	$I_{cp,mr}$
iC7-60SLGCG7-760A	AR12L	879	4	C	ABAT15C1000-AIB	1500	1000	14000
iC7-60SLGCG7-970A	AR12L	1121	4	C	ABAT15C1000-AIB	1500	1000	14000
iC7-60SLGCG7-1500	2 x AR12L	1733	8	C	ABAT15C1000-AIB	1500	1000	14000
iC7-60SLGCG7-1700	2 x AR12L	1964	8	C	ABAT15C1000-AIB	1500	1000	14000
iC7-60SLGCG7-1900	2 x AR12L	2195	8	C	ABAT15C1000-AIB	1500	1000	14000
iC7-60SLGCG7-2450	3 x AR12L	2830	12	C	ABAT15C1000-AIB	1500	1000	14000
iC7-60SLGCG7-2800	3 x AR12L	3234	12	C	ABAT15C1000-AIB	1500	1000	14000
iC7-60SLGCG7-3270	4 x AR12L	3776	16	C	ABAT15C1000-AIB	1500	1000	14000
iC7-60SLGCG7-3720	4 x AR12L	4297	16	C	ABAT15C1000-AIB	1500	1000	14000
iC7-60SLGCG7-4160	5 x AR12L	4804	20	C	ABAT15C1000-AIB	1500	1000	14000
iC7-60SLGCG7-4650	5 x AR12L	5370	20	C	ABAT15C1000-AIB	1500	1000	14000
iC7-60SLGCG7-5550	6 x AR12L	6410	24	C	ABAT15C1000-AIB	1500	1000	14000
iC7-60SLGCG7-6450	7 x AR12L	7449	28	C	ABAT15C1000-AIB	1500	1000	14000
iC7-60SLGCG7-7370	8 x AR12L	8511	32	C	ABAT15C1000-AIB	1500	1000	14000

10.5.8 DC Fuses for INU 450–830 V DC, IP00/Open Type

Table 86: DC Fuses for INU 450–830 V DC, IP00/Open Type (Mersen)

Model code ⁽¹⁾	Frame	Rated current I _L [A]	Number of fuses	Fuse size	Part number	Fuse U _n [V]	Fuse I _n [A]
iC7-60SLINA5-206AE00Fx	1x10L	206	2	73	PC73UD13C630TF	1250	630
iC7-60SLINA5-245AE00Fx		245					
iC7-60SLINA5-302AE00Fx		302					
iC7-60SLINA5-385AE00Fx		385			PC73UD13C800TF	1250	800
iC7-60SLINA5-480AE00Fx		480			PC73UD12C900TF	1200	900
iC7-60SLINA5-520AE00Fx		520			PC73UD95V11CTF	950	1100
iC7-60SLINA5-658AE00Fx	1x12L	658	4	73	PC73UD13C800TF	1250	800
iC7-60SLINA5-730AE00Fx		730			PC73UD12C900TF	1200	900
iC7-60SLINA5-820AE00Fx		820			PC73UD95V11CTF	950	1100
iC7-60SLINA5-880AE00Fx		880					
iC7-60SLINA5-1000E00Fx		1000					
iC7-60SLINA5-1270E00Fx	2x1x12L	1270	8	73	PC73UD13C800TF	1250	800
iC7-60SLINA5-1460E00Fx		1460			PC73UD12C900TF	1200	900
iC7-60SLINA5-1630E00Fx		1630			PC73UD95V11CTF	950	1100
iC7-60SLINA5-1760E00Fx		1760					
iC7-60SLINA5-1960E00Fx		1960					
iC7-60SLINA5-2150E00Fx	3x1x12L	2150	12	73	PC73UD12C900TF	1200	900
iC7-60SLINA5-2340E00Fx		2340			PC73UD95V11CTF	950	1100
iC7-60SLINA5-2510E00Fx		2510					
iC7-60SLINA5-2880E00Fx		2880					
iC7-60SLINA5-3120E00Fx	4x1x12L	3120	16	73	PC73UD12C900TF	1200	900
iC7-60SLINA5-3420E00Fx		3420			PC73UD95V11CTF	950	1100
iC7-60SLINA5-3820E00Fx		3820					
iC7-60SLINA5-4140E00Fx	5x1x12L	4140	20	73	PC73UD12C900TF	1200	900
iC7-60SLINA5-4500E00Fx		4500			PC73UD95V11CTF	950	1100
iC7-60SLINA5-4750E00Fx		4750					
iC7-60SLINA5-5220E00Fx	6x1x12L	5520	24	73	PC73UD95V11CTF	950	1100
iC7-60SLINA5-5680E00Fx		5680					

1) For example, iC7-60SLINA5-206AE00F4

Table 87: DC Fuses for INU 450–830 V DC, IP00/Open Type (Eaton/Bussmann)

Model code ⁽¹⁾	Frame	Rated current I_L [A]	Number of fuses	Fuse size	Part number	Fuse U_n [V]	Fuse I_n [A]		
iC7-60SLINA5-206AE00Fx	1x10L	206	2	3	180D6344	1000	630		
iC7-60SLINA5-245AE00Fx		245							
iC7-60SLINA5-302AE00Fx		302			180D6347			900	900
iC7-60SLINA5-385AE00Fx		385			180D6349			900	1100
iC7-60SLINA5-480AE00Fx		480			180D8583			500	1400
iC7-60SLINA5-520AE00Fx		520							
iC7-60SLINA5-658AE00Fx	1x12L	658	4	3	180D6347	900	900		
iC7-60SLINA5-730AE00Fx		730			180D6349			900	1100
iC7-60SLINA5-820AE00Fx		820							
iC7-60SLINA5-880AE00Fx		880			180D8583			500	1400
iC7-60SLINA5-1000E00Fx		1000							
iC7-60SLINA5-1270E00Fx	2x1x12L	1270	8	3	180D6347	900	900		
iC7-60SLINA5-1460E00Fx		1460			180D6349			900	1100
iC7-60SLINA5-1630E00Fx		1630							
iC7-60SLINA5-1760E00Fx		1760			180D8583			500	1400
iC7-60SLINA5-1960E00Fx		1960							
iC7-60SLINA5-2150E00Fx	3x1x12L	2150	12	3	180D6349	900	1100		
iC7-60SLINA5-2340E00Fx		2340							
iC7-60SLINA5-2510E00Fx		2510			180D8583			500	1400
iC7-60SLINA5-2880E00Fx		2880							
iC7-60SLINA5-3120E00Fx	4x1x12L	3120	16	3	180D6349	900	1100		
iC7-60SLINA5-3420E00Fx		3420			180D8583			500	1400
iC7-60SLINA5-3820E00Fx		3820							
iC7-60SLINA5-4140E00Fx	5x1x12L	4140	20	3	180D6349	900	1100		
iC7-60SLINA5-4500E00Fx		4500			180D8583			500	1400
iC7-60SLINA5-4750E00Fx		4750							
iC7-60SLINA5-5220E00Fx	6x1x12L	5520	24	3	180D8583	500	1400		
iC7-60SLINA5-5680E00Fx		5680							

1) For example, iC7-60SLINA5-206AE00F4

10.5.9 DC Fuses for INU 640–1100 V DC, IP00/Open Type

[Table 88](#) for fuse recommendation is also applicable to the voltage class B5.

Table 88: DC Fuses for INU 640–1100 V DC, IP00/Open Type (Mersen)

Model code ⁽¹⁾	Frame	Rated current I _L [A]	Number of fuses	Fuse size	Part number	Fuse U _n [V]	Fuse I _n [A]
iC7-60SLIN07-170AE00Fx	1x10L	170	2	73	PC73UD13C630TF	1250	630
iC7-60SLINB5-206AE00Fx ⁽²⁾		206					
iC7-60SLIN07-208AE00Fx		208					
iC7-60SLINB5-245AE00Fx ⁽²⁾		245					
iC7-60SLIN07-261AE00Fx		261			PC73UD13C800TF	800	
iC7-60SLINB5-302AE00Fx ⁽²⁾		302					
iC7-60SLIN07-325AE00Fx		325					
iC7-60SLIN07-365AE00Fx		365					
iC7-60SLINB5-385AE00Fx ⁽²⁾		385					
iC7-60SLIN07-416AE00Fx		416					
iC7-60SLIN07-465AE00Fx	1x12L	465	4	73	PC73UD13C800TF	1250	800
iC7-60SLIN07-525AE00Fx		525					
iC7-60SLIN07-590AE00Fx		590					
iC7-60SLIN07-650AE00Fx		650			PC73UD12C900TF	1200	900
iC7-60SLIN07-730AE00Fx		730					
iC7-60SLIN07-820AE00Fx		820					
iC7-60SLIN07-945AE00Fx	2 x 1x12L	945	8	73	PC73UD13C800TF	1250	800
iC7-60SLIN07-1060E00Fx		1060					
iC7-60SLIN07-1230E00Fx		1230					
iC7-60SLIN07-1400E00Fx		1400			PC73UD12C900TF	1200	900
iC7-60SLIN07-1500E00Fx		1500					
iC7-60SLIN07-1640E00Fx		1640					
iC7-60SLIN07-1795E00Fx	3 x 1x12L	1795	12	73	PC73UD13C800TF	1250	800
iC7-60SLIN07-2080E00Fx		2080			PC73UD12C900TF	1200	900
iC7-60SLIN07-2300E00Fx		2300					
iC7-60SLIN07-2500E00Fx		2500					
iC7-60SLIN07-2830E00Fx	4 x 1x12L	2830	16	73	PC73UD12C900TF	1200	900
iC7-60SLIN07-3050E00Fx		3050					
iC7-60SLIN07-3260E00Fx		3260					
iC7-60SLIN07-3500E00Fx	5 x 1x12L	3500	20	73	PC73UD12C900TF	1200	900
iC7-60SLIN07-4035E00Fx		4035					
iC7-60SLIN07-4400E00Fx	6 x 1x12L	4400	24	73	PC73UD12C900TF	1200	900
iC7-60SLIN07-4850E00Fx		4850					
iC7-60SLIN07-5300E00Fx	7 x 1x12L	5300	28	73	PC73UD12C900TF	1200	900
iC7-60SLIN07-5600E00Fx		5600					

Table 88: DC Fuses for INU 640–1100 V DC, IP00/Open Type (Mersen) - (continued)

Model code ⁽¹⁾	Frame	Rated current I _L [A]	Number of fuses	Fuse size	Part number	Fuse U _n [V]	Fuse I _n [A]
iC7-60SLIN07-6100E00Fx	8 x Ix12L	6100	32	73	PC73UD12C900TF	1200	900
iC7-60SLIN07-6400E00Fx		6400					

1) For example, iC7-60SLIN07-140AE00F4

2) Only for B5 voltage class

[Table 89](#) for fuse recommendation is also applicable to the voltage class B5.

Table 89: DC Fuses for INU 640–1100 V DC, IP00/Open Type (Eaton/Bussmann)

Model code ⁽¹⁾	Frame	Rated current I _L [A]	Number of fuses	Fuse size	Part number	Fuse U _n [V]	Fuse I _n [A]
iC7-60SLIN07-170AE00Fx	I_10L	170	2	3	180D6344	1000	630
iC7-60SLINB5-206AE00Fx ⁽²⁾		206					
iC7-60SLIN07-208AE00Fx		208					
iC7-60SLINB5-245AE00Fx ⁽²⁾		245					
iC7-60SLIN07-261AE00Fx		261			180D6347	900	900
iC7-60SLINB5-302AE00Fx ⁽²⁾		302					
iC7-60SLIN07-325AE00Fx		325					
iC7-60SLIN07-365AE00Fx		365					
iC7-60SLINB5-385AE00Fx ⁽²⁾		385					
iC7-60SLIN07-416AE00Fx		416					
iC7-60SLIN07-465AE00Fx	I_12L	465	4	3	180D6347	900	900
iC7-60SLIN07-525AE00Fx		525					
iC7-60SLIN07-590AE00Fx		590					
iC7-60SLIN07-650AE00Fx		650			180D6349	900	1100
iC7-60SLIN07-730AE00Fx		730					
iC7-60SLIN07-820AE00Fx		820					
iC7-60SLIN07-945AE00Fx	2 x I_12L	945	8	3	180D6347	900	900
iC7-60SLIN07-1060E00Fx		1060					
iC7-60SLIN07-1230E00Fx		1230					
iC7-60SLIN07-1400E00Fx		1400			180D6349	900	1100
iC7-60SLIN07-1500E00Fx		1500					
iC7-60SLIN07-1640E00Fx		1640					
iC7-60SLIN07-1795E00Fx	3 x I_12L	1795	12	3	180D6347	900	900
iC7-60SLIN07-2080E00Fx		2080			180D6349	900	1100
iC7-60SLIN07-2300E00Fx		2300					
iC7-60SLIN07-2500E00Fx		2500					

Table 89: DC Fuses for INU 640–1100 V DC, IP00/Open Type (Eaton/Bussmann) - (continued)

Model code ⁽¹⁾	Frame	Rated current I_L [A]	Number of fuses	Fuse size	Part number	Fuse U_n [V]	Fuse I_n [A]
iC7-60SLIN07-2830E00Fx	4 x I_12L	2830	16	3	180D6349	900	1100
iC7-60SLIN07-3050E00Fx		3050					
iC7-60SLIN07-3260E00Fx		3260					
iC7-60SLIN07-3500E00Fx	5 x I_12L	3500	20	3	180D6349	900	1100
iC7-60SLIN07-4035E00Fx		4035					
iC7-60SLIN07-4400E00Fx	6 x I_12L	4400	24	3	180D6349	900	1100
iC7-60SLIN07-4850E00Fx		4850					
iC7-60SLIN07-5300E00Fx	7 x I_12L	5300	28	3	180D6349	900	1100
iC7-60SLIN07-5600E00Fx		5600					
iC7-60SLIN07-6100E00Fx	8 x I_12L	6100	32	3	180D6349	900	1100
iC7-60SLIN07-6400E00Fx		6400					

1) For example, iC7-60SLIN07-170AE00F4

2) Only for B5 voltage class

10.5.10 AC Fuses for INU, IP00/Open Type in Generator Use

Short-circuit protection of inverter modules is required in generator use cases. Fast-acting semiconductor aR fuses are recommended for short-circuit protection of inverter modules in generator use cases according to the tables in [AC fuses for INU 450–830 V DC, IP00/open type in generator use](#) and [AC fuses for INU 640–1100 V DC, IP00/open type in generator use](#). Alternative protection methods, for example, circuit breaker are required in case the short circuit contribution from the generator is not high enough to trip the fuses ($I_{cp,mr}$, refer to the tables in [AC fuses for INU 450–830 V DC, IP00/open type in generator use](#) and [AC fuses for INU 640–1100 V DC, IP00/open type in generator use](#)).

The circuit breaker tripping functions can be used if the circuit breaker let-through energy I^2t is lower than the fuse clearing I^2t , refer to the tables in [AC fuses for INU 450–830 V DC, IP00/open type in generator use](#) and [AC fuses for INU 640–1100 V DC, IP00/open type in generator use](#).

An alternative method is to trip the circuit breaker based on the inverter module trip. In this case, the circuit breaker needs to open quickly enough so that the let-through energy I^2t is lower than the fuse clearing I^2t .

- Circuit breaker trip circuit needs to be connected to the inverter module digital output or relay output.
- Inverter module needs to be parametrized so that any fault or trip results in immediate opening of the circuit breaker. The delay from the fault detection to signal out from the inverter module is less than 6 ms.
- When the inverter module reaches the overcurrent level, the circuit breaker should open as soon as possible to limit the damage in the system.
- Motor breaker control functionality of the generator application can be used to assign the circuit breaker opening digital output or relay output.

AC fuses for INU 450–830 V DC, IP00/open type in generator use

Table 90: AC-side Fuses for Inverter Module with +AEU1/+AEU2/+AE10, 380–500 V AC (Mersen)

Model code	Frame	Rated current I_L [A]	Number of fuses	Fuse size	Part number	Fuse U_n [V]	Fuse I_n [A]	$I_{cp, mr}$ [A]	Fuse Clearing I^2t at 500 V AC [A ² s]
iC7-60SLINA5-206AE00Fx	1x10L	206	6	31	PC31UD69V315TF	690	315	3600	113 520
iC7-60SLINA5-245AE00Fx		245							
iC7-60SLINA5-302AE00Fx		302							
iC7-60SLINA5-385AE00Fx		385							
iC7-60SLINA5-480AE00Fx		480							
iC7-60SLINA5-520AE00Fx		520							
iC7-60SLINA5-658AE00Fx	1x12L	658	3	44	PC44UD75V12CTQ	750	1200	7200	384 300
iC7-60SLINA5-730AE00Fx		730							
iC7-60SLINA5-820AE00Fx		820							
iC7-60SLINA5-880AE00Fx		880							
iC7-60SLINA5-1000E00Fx		1000							
iC7-60SLINA5-1270E00Fx	2x1x12L	1270	6	44	PC44UD75V12CTQ	750	1200	–	384 300
iC7-60SLINA5-1460E00Fx		1460							
iC7-60SLINA5-1630E00Fx		1630							
iC7-60SLINA5-1760E00Fx		1760							
iC7-60SLINA5-1960E00Fx		1960							
iC7-60SLINA5-2150E00Fx	3x1x12L	2150	9	44	PC44UD75V12CTQ	750	1200	–	384 000
iC7-60SLINA5-2340E00Fx		2340							
iC7-60SLINA5-2510E00Fx		2510							
iC7-60SLINA5-2880E00Fx		2880							
iC7-60SLINA5-3120E00Fx	4x1x12L	3120	12	44	PC44UD75V12CTQ	750	1200	–	384 000
iC7-60SLINA5-3420E00Fx		3420							
iC7-60SLINA5-3820E00Fx		3820							
iC7-60SLINA5-4140E00Fx	5x1x12L	4140	15	44	PC44UD75V16CTQ	750	1600	–	1 008 000
iC7-60SLINA5-4500E00Fx		4500							
iC7-60SLINA5-4750E00Fx		4750							
iC7-60SLINA5-5220E00Fx	6x1x12L	5220	18	44	PC44UD75V16CTQ	750	1600	–	1 008 000
iC7-60SLINA5-5680E00Fx		5680							

Table 91: AC-side Fuses for Inverter Module with +AEU1/+AEU2/+AE10, 380–500 V AC (Eaton/Bussmann)

Model code	Frame	Rated current I_L [A]	Number of fuses	Fuse size	Part number	Fuse U_n [V]	Fuse I_n [A]	$I_{cp, mr}$ [A]	Fuse Clearing I^2t at 500 V AC [A ² s]
iC7-60SLINA5-206AE00Fx	1x10L	206	6	1	170M4411	690	350	3800	174 640
iC7-60SLINA5-245AE00Fx		245							
iC7-60SLINA5-302AE00Fx		302							
iC7-60SLINA5-385AE00Fx		385							
iC7-60SLINA5-480AE00Fx		480							
iC7-60SLINA5-520AE00Fx		520			170M4414	690	500	6500	503 200
iC7-60SLINA5-658AE00Fx	1x12L	658	3	4	170M7348	690	1250	6300	573 500
iC7-60SLINA5-730AE00Fx		730							
iC7-60SLINA5-820AE00Fx		820			170M7349	690	1800	13100	1 883 000
iC7-60SLINA5-880AE00Fx		880							
iC7-60SLINA5-1000E00Fx		1000							
iC7-60SLINA5-1270E00Fx	2x1x12L	1270	6	4	170M7348	690	1250	–	573 500
iC7-60SLINA5-1460E00Fx		1460							
iC7-60SLINA5-1630E00Fx		1630			170M7349	690	1800	–	1 883 300
iC7-60SLINA5-1760E00Fx		1760							
iC7-60SLINA5-1960E00Fx		1960							
iC7-60SLINA5-2150E00Fx	3x1x12L	2150	9	4	170M7348	690	1250	–	573 500
iC7-60SLINA5-2340E00Fx		2340							
iC7-60SLINA5-2510E00Fx		2510			170M7349	690	1800	–	1 883 500
iC7-60SLINA5-2880E00Fx		2880							
iC7-60SLINA5-3120E00Fx	4x1x12L	3120	12	4	170M7348	690	1250	–	573 500
iC7-60SLINA5-3420E00Fx		3420							
iC7-60SLINA5-3820E00Fx		3820							
iC7-60SLINA5-4140E00Fx	5x1x12L	4140	15	4	170M7349	690	1800	–	1 883 300
iC7-60SLINA5-4500E00Fx		4500							
iC7-60SLINA5-4750E00Fx		4750							
iC7-60SLINA5-5220E00Fx	6x1x12L	5220	18	4	170M7349	690	1800	–	1 883 300
iC7-60SLINA5-5680E00Fx		5680							

AC fuses for INU 640–1100 V DC, IP00/open type in generator use

[Table 92](#) for fuse recommendation is also applicable to the voltage class B5.

Table 92: AC-side Fuses for Inverter Module with +AEU1/+AEU2/+AE10, 525–690 V AC (Mersen)

Model code	Frame	Rated current I_L [A]	Number of fuses	Fuse size	Part number	Fuse U_n [V]	Fuse I_n [A]	$I_{cp, mr}$ [A]	Fuse Clearing I^2t at 690 V AC [A ² s]
iC7-60SLIN07-170AE00Fx	1x10L	170	6	31	PC31UD69V250TF	690	250	2900	112 000
iC7-60SLINB5-206AE00Fx ⁽¹⁾		206	6						
iC7-60SLIN07-208AE00Fx		208	6						
iC7-60SLINB5-245AE00Fx ⁽¹⁾		245	6						
iC7-60SLIN07-261AE00Fx		261	6						
iC7-60SLINB5-302AE00Fx ⁽¹⁾		302	6						
iC7-60SLIN07-325AE00Fx		325	6						
iC7-60SLIN07-365AE00Fx	1x12L	365	6	31	PC31UD69V315TF	690	315	3600	176 000
iC7-60SLINB5-385AE00Fx ⁽¹⁾		385	6						
iC7-60SLIN07-416AE00Fx		416	6						
iC7-60SLIN07-465AE00Fx	1x12L	465	3	44	PC44UD75V12CTQ	750	1200	7200	549 000
iC7-60SLIN07-525AE00Fx		525	3						
iC7-60SLIN07-590AE00Fx		590	3						
iC7-60SLIN07-650AE00Fx		650	3						
iC7-60SLIN07-730AE00Fx		730	3						
iC7-60SLIN07-820AE00Fx		820	3						
iC7-60SLIN07-945AE00Fx	2 x 1x12L	945	6	44	PC44UD75V12CTQ	750	1200	–	549 000
iC7-60SLIN07-1060E00Fx		1060	6						
iC7-60SLIN07-1230E00Fx		1230	6						
iC7-60SLIN07-1400E00Fx		1400	6						
iC7-60SLIN07-1500E00Fx		1500	6						
iC7-60SLIN07-1640E00Fx		1640	6						
iC7-60SLIN07-1795E00Fx	3 x 1x12L	1795	9	44	PC44UD75V12CTQ	750	1200	–	549 000
iC7-60SLIN07-2080E00Fx		2080	9						
iC7-60SLIN07-2300E00Fx		2300	9						
iC7-60SLIN07-2460E00Fx		2500	9						
iC7-60SLIN07-2830E00Fx	4 x 1x12L	2830	12	44	PC44UD75V12CTQ	750	1200	–	549 000
iC7-60SLIN07-3050E00Fx		3050	12						
iC7-60SLIN07-3260E00Fx		3260	12						
iC7-60SLIN07-3500E00Fx	5 x 1x12L	3500	15	44	PC44UD75V12CTQ	750	1200	–	549 000
iC7-60SLIN07-4035E00Fx		4035	15						
iC7-60SLIN07-4400E00Fx	6 x 1x12L	4400	18	44	PC44UD75V12CTQ	750	1200	–	549 000
iC7-60SLIN07-4850E00Fx		4850	18						

Table 92: AC-side Fuses for Inverter Module with +AEU1/+AEU2/+AE10, 525–690 V AC (Mersen) - (continued)

Model code	Frame	Rated current I_L [A]	Number of fuses	Fuse size	Part number	Fuse U_n [V]	Fuse I_n [A]	$I_{cp, mr}$ [A]	Fuse Clearing I^2t at 690 V AC [A ² s]
iC7-60SLIN07-5300E00Fx	7 x lx12L	5300	21	44	PC44UD75V12CTQ	750	1200	–	549 000
iC7-60SLIN07-5600E00Fx		5600	21						
iC7-60SLIN07-6100E00Fx	8 x lx12L	6100	24	44	PC44UD75V12CTQ	750	1200	–	549 000
iC7-60SLIN07-6400E00Fx		6400	24						

1) Only for B5 voltage class.

Table 93 for fuse recommendation is also applicable to the voltage class B5.

Table 93: AC-side Fuses for Inverter Module with +AEU1/+AEU2/+AE10, 525–690 V AC (Eaton/Bussmann)

Model code	Frame	Rated current I_L [A]	Number of fuses	Fuse size	Part number	Fuse U_n [V]	Fuse I_n [A]	$I_{cp, mr}$ [A]	Fuse Clearing I^2t at 690 V AC [A ² s]
iC7-60SLIN07-170AE00Fx	I_10L	170	6	1	170M4410	690	315	3300	194 040
iC7-60SLINB5-206AE00Fx ⁽¹⁾		206	6						
iC7-60SLIN07-208AE00Fx		208	6						
iC7-60SLINB5-245AE00Fx ⁽¹⁾		245	6						
iC7-60SLIN07-261AE00Fx		261	6						
iC7-60SLINB5-302AE00Fx ⁽¹⁾		302	6						
iC7-60SLIN07-325AE00Fx		1	325	6	170M4411	690	350	3900	272 580
iC7-60SLIN07-365AE00Fx			365	6					
iC7-60SLINB5-385AE00Fx ⁽¹⁾			385	6					
iC7-60SLIN07-416AE00Fx			416	6					
iC7-60SLIN07-465AE00Fx	I_12L		465	3					
iC7-60SLIN07-525AE00Fx		525	3						
iC7-60SLIN07-590AE00Fx		590	3						
iC7-60SLIN07-650AE00Fx		650	3						
iC7-60SLIN07-730AE00Fx		730	3						
iC7-60SLIN07-820AE00Fx		820	3						

Table 93: AC-side Fuses for Inverter Module with +AEU1/+AEU2/+AE10, 525–690 V AC (Eaton/Bussmann) - (continued)

Model code	Frame	Rated current I_L [A]	Number of fuses	Fuse size	Part number	Fuse U_n [V]	Fuse I_n [A]	$I_{cp, mr}$ [A]	Fuse Clearing I^2t at 690 V AC [A ² s]
iC7-60SLIN07-945AE00Fx	2 x I_12L	945	6	4	170M7348	690	1250	–	813 750
iC7-60SLIN07-1060E00Fx		1060	6						
iC7-60SLIN07-1230E00Fx		1230	6						
iC7-60SLIN07-1400E00Fx		1400	6						
iC7-60SLIN07-1500E00Fx		1500	6						
iC7-60SLIN07-1640E00Fx		1640	6						
iC7-60SLIN07-1795E00Fx	3 x I_12L	1795	9	4	170M7348	690	1250	–	813 750
iC7-60SLIN07-2080E00Fx		2080	9						
iC7-60SLIN07-2300E00Fx		2300	9						
iC7-60SLIN07-2500E00Fx		2500	9						
iC7-60SLIN07-2830E00Fx	4 x I_12L	2830	12	4	170M7348	690	1250	–	813 750
iC7-60SLIN07-3050E00Fx		3050	12						
iC7-60SLIN07-3260E00Fx		3260	12						
iC7-60SLIN07-3500E00Fx	5 x I_12L	3500	15	4	170M7348	690	1250	–	813 750
iC7-60SLIN07-4035E00Fx		4035	15						
iC7-60SLIN07-4400E00Fx	6 x I_12L	4400	18	4	170M7348	690	1250	–	813 750
iC7-60SLIN07-4850E00Fx		4850	18						
iC7-60SLIN07-5300E00Fx	7 x I_12L	5300	21	4	170M7348	690	1250	–	813 750
iC7-60SLIN07-5600E00Fx		5600	21						
iC7-60SLIN07-6100E00Fx	8 x I_12L	6100	24	4	170M7348	690	1250	–	813 750
iC7-60SLIN07-6400E00Fx		6400	24						

1) Only for B5 voltage class.

Table 94: AC-side Fuses for Inverter Module with +AES1/+AEZ1, 525–690 V AC

Model code	Frame	Rated current I_L [A]	Number of fuses	Fuse size	Part number	Fuse U_n [V]	Fuse I_n [A]	$I_{cp, mr}$ [A]	Fuse Clearing I^2t at 690 V AC [A ² s]
iC7-60SLIN07-465AE00Fx	1x12L	465	3	44	PC44UD75V12CTQ	750	1200	7200	549 000
iC7-60SLIN07-525AE00Fx		525	3						
iC7-60SLIN07-590AE00Fx		590	3						
iC7-60SLIN07-650AE00Fx		650	3						
iC7-60SLIN07-730AE00Fx		730	3						

Table 94: AC-side Fuses for Inverter Module with +AES1/+AEZ1, 525–690 V AC - (continued)

Model code	Frame	Rated current I_L [A]	Number of fuses	Fuse size	Part number	Fuse U_n [V]	Fuse I_n [A]	$I_{cp, mr}$ [A]	Fuse Clearing I^2t at 690 V AC [A ² s]
iC7-60SLIN07-945AE00Fx	2 x lx12L	945	6	44	PC44UD75V12CTQ	750	1200	–	549 000
iC7-60SLIN07-1060E00Fx		1060	6						
iC7-60SLIN07-1230E00Fx		1230	6						
iC7-60SLIN07-1400E00Fx		1400	6						
iC7-60SLIN07-1640E00Fx		1640	6						
iC7-60SLIN07-1795E00Fx	3 x lx12L	1795	9	44	PC44UD75V12CTQ	750	1200	–	549 000
iC7-60SLIN07-2080E00Fx		2080	9						
iC7-60SLIN07-2830E00Fx	4 x lx12L	2830	12	44	PC44UD75V12CTQ	750	1200	–	549 000
iC7-60SLIN07-3500E00Fx	5 x lx12L	3500	15	44	PC44UD75V12CTQ	750	1200	–	549 000
iC7-60SLIN07-4400E00Fx	6 x lx12L	4400	18	44	PC44UD75V12CTQ	750	1200	–	549 000

The maximum air temperature around the fuses inside the enclosure is:

- 60 °C (140 °F) with 2 m/s forced airflow
- 50 °C (122 °F) with 1 m/s forced airflow
- 40 °C (104 °F) with natural cooling (AN)

Derating of the fuses is required in case the total current harmonic distortion THDi is higher than 15%. Consult Danfoss if THDi is higher than 15%.

10.5.11 DC-bus Fuses for DC/DC Converter, IP00/Open Type

Table 95: DC-bus Fuses for DC/DC Converter, Voltage Classes B5 and 07, IP00/Open Type

Model code ⁽¹⁾	Frame	Rated current (I_L) [A]	Number of fuses	Fuse size	Part number (Mersen)	Fuse U_n [V]	Fuse I_n [A]
iC7-60SLDCxx-300AE00F4	DR10L	300	2	73	PC73UD13C630TF	1250	630
iC7-60SLDCxx-360AE00F4		360	2				
iC7-60SLDCxx-420AE00F4		420	2				
iC7-60SLDCxx-480AE00F4		480	2				
iC7-60SLDCxx-570AE00F4		570	2				
iC7-60SLDCxx-720AE00F4	DR12L	720	4	73	PC73UD13C630TF	1250	630
iC7-60SLDCxx-840AE00F4		840	4				
iC7-60SLDCxx-960AE00F4		960	4				
iC7-60SLDCxx-1080E00F4		1080	4				
iC7-60SLDCxx-1200E00F4		1200	4				

Table 95: DC-bus Fuses for DC/DC Converter, Voltage Classes B5 and 07, IP00/Open Type - (continued)

Model code ⁽¹⁾	Frame	Rated current (I _n) [A]	Number of fuses	Fuse size	Part number (Mersen)	Fuse U _n [V]	Fuse I _n [A]
iC7-60SLDCxx-1440E00F4	2 x DR12L	1440	8	73	PC73UD13C630TF	1250	630
iC7-60SLDCxx-1680E00F4		1680	8	73	PC73UD13C800TF	1250	800
iC7-60SLDCxx-1920E00F4		1920	8				
iC7-60SLDCxx-2160E00F4		2160	8	73	PC73UD12C900TF	1200	900
iC7-60SLDCxx-2400E00F4		2400	8				
iC7-60SLDCxx-2880E00F4	3 x DR12L	2880	12	73	PC73UD13C800TF	1250	800
iC7-60SLDCxx-3240E00F4		3240	12	73	PC73UD12C900TF	1200	900
iC7-60SLDCxx-3600E00F4		3600	12				

1) xx = B5 or 07

10.5.12 Source DC+ Fuses for DC/DC Converter, IP00/Open Type

Table 96: Source DC+ Fuses for DC/DC Converter, Voltage Classes B5 and 07, IP00/Open Type

Model code ⁽¹⁾	Frame	Rated current (I _n) [A]	Number of fuses	Fuse size	Part number (Mersen)	Fuse U _n [V]	Fuse I _n [A]
iC7-60SLDCxx-300AE00F4	DR10L	300	3	72	D72SG120V250QF	1200	250
iC7-60SLDCxx-360AE00F4		360	3				
iC7-60SLDCxx-420AE00F4		420	3				
iC7-60SLDCxx-480AE00F4		480	3	72	D72SG120V315QF	1200	315
iC7-60SLDCxx-570AE00F4		570	3				
iC7-60SLDCxx-720AE00F4	DR12L	720	3	272	D272SG120V500QF	1200	500
iC7-60SLDCxx-840AE00F4		840	3				
iC7-60SLDCxx-960AE00F4		960	3				
iC7-60SLDCxx-1080E00F4		1080	3	272	D272SG120V630QF	1200	630
iC7-60SLDCxx-1200E00F4		1200	3				
iC7-60SLDCxx-1440E00F4	2 x DR12L	1440	6	272	D272SG120V500QF	1200	500
iC7-60SLDCxx-1680E00F4		1680	6				
iC7-60SLDCxx-1920E00F4		1920	6				
iC7-60SLDCxx-2160E00F4		2160	6	272	D272SG120V630QF	1200	630
iC7-60SLDCxx-2400E00F4		2400	6				
iC7-60SLDCxx-2880E00F4	3 x DR12L	2880	9	272	D272SG120V500QF	1200	500
iC7-60SLDCxx-3240E00F4		3240	9	272	D272SG120V630QF	1200	630
iC7-60SLDCxx-3600E00F4		3600	9				

1) xx = B5 or 07

10.5.13 Source DC- Fuses for DC/DC Converter, IP00/Open Type

Table 97: Source DC- Fuses for DC/DC Converter, Voltage Classes B5 and 07, IP00/Open Type

Model code ⁽¹⁾	Frame	Rated current (I _L) [A]	Number of fuses	Fuse size	Part number (Mersen)	Fuse U _n [V]	Fuse I _n [A]
iC7-60SLDCxx-300AE00F4	DR10L	300	1	73	PC73UD13C630TF	1250	630
iC7-60SLDCxx-360AE00F4		360	1				
iC7-60SLDCxx-420AE00F4		420	1	73	PC73UD13C800TF	1250	800
iC7-60SLDCxx-480AE00F4		480	1	73	PC73UD12C900TF	1200	900
iC7-60SLDCxx-570AE00F4		570	1	73			
iC7-60SLDCxx-720AE00F4	DR12L	720	2	73	PC73UD13C630TF	1250	630
iC7-60SLDCxx-840AE00F4		840	2				
iC7-60SLDCxx-960AE00F4		960	2				
iC7-60SLDCxx-1080E00F4		1080	2	73	PC73UD12C900TF	1200	900
iC7-60SLDCxx-1200E00F4		1200	2				
iC7-60SLDCxx-1440E00F4	2 x DR12L	1440	4	73	PC73UD13C630TF	1250	630
iC7-60SLDCxx-1680E00F4		1680	4				
iC7-60SLDCxx-1920E00F4		1920	4				
iC7-60SLDCxx-2160E00F4		2160	4	73	PC73UD12C900TF	1200	900
iC7-60SLDCxx-2400E00F4		2400	4				
iC7-60SLDCxx-2880E00F4	3 x DR12L	2880	6	73	PC73UD13C800TF	1250	800
iC7-60SLDCxx-3240E00F4		3240	6				
iC7-60SLDCxx-3600E00F4		3600	6				

1) xx = B5 or 07

10.5.14 DC Fuses for BCU, Voltage Class B5 and 07, IP00/Open Type

Table 98: DC Fuses for BCU, Voltage Class B5 and 07, IP00/Open Type (Mersen)

Model code ⁽¹⁾	Frame	Rated current I _L [A]	Number of fuses	Fuse size	Part number	Fuse U _n [V]	Fuse I _n [A]
iC7-60SLBRxx-170A	BM10L/BR10L	170	2	73	PC73UD13C630TF	1250	630
iC7-60SLBRxx-261A		261					
iC7-60SLBRxx-416A		416			PC73UD12C900TF	1200	900
iC7-60SLBRxx-525A	BM12L/BR12L	525	4	73	PC73UD13C800TF	1250	800
iC7-60SLBRxx-650A		650					
iC7-60SLBRxx-820A		820			PC73UD12C900TF	1200	900
iC7-60SLBRxx-1060	2xBM12L/2xBR12L	1060	8	73	PC73UD13C800TF	1250	800
iC7-60SLBRxx-1400		1400					
iC7-60SLBRxx-1640		1640			PC73UD12C900TF	1200	900

1) xx = B5 or 07.

10.5.15 AC Fuses and Circuit Breakers for L Filter, Voltage Class A5

The system modules with a mains contactor or a main switch, and a net-side L filter must be protected with branch circuit fuses or a circuit breaker. Check the coordination type in the contactor datasheet with the corresponding gG fuse. The fuse ratings are based on a maximum ambient temperature of 60 °C (140 °F), and when using gR fuses, a minimum airflow of 3 m/s is required. gG fuses do not require additional cooling. Check the selectivity with upstream protective devices. Select the circuit breaker I_{cu}/I_{cw} value according to the supply short-circuit current capability.

Table 99: AC Fuses and Circuit Breakers for L Filter +AEZ3, Voltage Class A5

Model code	System module: Rated current IL [A]	IEC gG fuses (at 60 °C (140 °F) ambient, no cooling)	gR fuses (at 60 °C (140 °F) ambient)	Mersen gR fuse type TTF	Recommended circuit breaker type ABB Emax2 (at 60 °C (140 °F) ambient)	Circuit breaker trip unit settings: Ekip DIP/Touch/ Hi-Touch LI
OF7Z5-M-LC-07-500A-A1-E00-F4	271	gG 400 A	gR 800 A	PC73GB69V8 00TF	–	–
OF7Z5-M-LC-07-500A-A1-E00-F4	317	gG 400 A	gR 800 A	PC73GB69V8 00TF	–	–
OF7Z5-M-LC-07-500A-A1-E00-F4	400	gG 500 A	2 x gR 800 A	PC73GB69V8 00TF	–	–
OF7Z5-M-LC-07-500A-A1-E00-F4	460	gG 630 A	2 x gR 800 A	PC73GB69V8 00TF	–	–
OF7Z5-M-LC-07-1000-A1-E00-F4	520	gG 630 A	2 x gR 800 A	PC73GB69V8 00TF	–	–
OF7Z5-M-LC-07-1000-A1-E00-F4	580	gG 800 A	2 x gR 800 A	PC73GB69V8 00TF	–	–
OF7Z5-M-LC-07-1000-A1-E00-F4	650	gG 800 A	2 x gR 800 A	PC73GB69V8 00TF	–	–
OF7Z5-M-LC-07-1000-A1-E00-F4	730	gG 1000 A	2 x gR 800 A	PC73GB69V8 00TF	–	–
OF7Z5-M-LC-07-1000-A1-E00-F4	816	gG 1000 A	3 x gR 1000 A	PC73GB69V1 0CTF	–	–
OF7Z5-M-LC-07-1000-A1-E00-F4	970	gG 1250 A	3 x gR 1000 A	PC73GB69V1 0CTF	–	–
OF7Z5-M-LC-07-1640-A1-E00-F4	1040	gG 1250 A	2 x gR 800 A	PC73GB69V8 00TF	E1.2 1250 LI	I: 1,5 x IN = 1875 A ±10 %, t ≤ 30 ms L: 1 x IN = 1250 A, t = 3 s
OF7Z5-M-LC-07-1640-A1-E00-F4	1210	gG 1600 A	2 x gR 900 A	PC73GB69V9 00TF	E1.2 1600 LI	I: 1,5 x IN = 2400 A ±10 %, t ≤ 30 ms L: 0,9 x IN = 1440 A, t = 3 s
OF7Z5-M-LC-07-1640-A1-E00-F4	1300	gG 1600 A	2 x gR 1000 A	PC73GB69V1 0CTF	E1.2 1600 LI	I: 1,5 x IN = 2400 A ±10 %, t ≤ 30 ms L: 1,0 x IN = 1600 A, t = 3 s

Table 99: AC Fuses and Circuit Breakers for L Filter +AEZ3, Voltage Class A5 - (continued)

Model code	System module: Rated current IL [A]	IEC gG fuses (at 60 °C (140 °F) ambient, no cooling)	gR fuses (at 60 °C (140 °F) ambient)	Mersen gR fuse type TTF	Recommended circuit breaker type ABB Emax2 (at 60 °C (140 °F) ambient)	Circuit breaker trip unit settings: Ekip DIP/Touch/Hi-Touch LI
OF7Z5-M-LC-07-1640-A1-E00-F4	1410	2 x gG 1000 A	3 x gR 800 A	PC73GB69V8 00TF	E1.2 1600 LI	I: 1,5 x IN = 2400 A ±10 %, t ≤ 30 ms L: 1,0 x IN = 1600 A, t = 3 s
OF7Z5-M-LC-07-1640-A1-E00-F4	1630	2 x gG 1000 A	3 x gR 1000 A	PC73GB69V1 0CTF	E2.2 2000 LI	I: 1,5 x IN = 3000 A ±10 %, t ≤ 30 ms L: 1,0 x IN = 2000 A, t = 3 s
OF7Z5-M-LC-07-2300-A1-E00-F4	1900	2 x gG 1250 A	3 x gR 1000 A	PC73GB69V1 0CTF	E2.2 2500 LI	I: 1,5 x IN = 3750 A ±10 %, t ≤ 30 ms L: 0,9 x IN = 2250 A, t = 3 s
OF7Z5-M-LC-07-2300-A1-E00-F4	2080	2 x gG 1250 A	4 x gR 800 A	PC73GB69V8 00TF	E2.2 2500 LI	I: 1,5 x IN = 3750 A ±10 %, t ≤ 30 ms L: 1,0 x IN = 2500 A, t = 3 s
OF7Z5-M-LC-07-2300-A1-E00-F4	2200	3 x gG 1000 A	4 x gR 900 A	PC73GB69V9 00TF	E2.2 2500 LI	I: 1,5 x IN = 3750 A ±10 %, t ≤ 30 ms L: 1,0 x IN = 2500 A, t = 3 s
2xOF7Z5-M-LC-07-1640-A1-E00-F4	2450	2 x (2 x gG 800 A)	2 x (2 x gR 1000 A)	PC73GB69V1 0CTF	E4.2 3200 LI	I: 1,5 x IN = 4800 A ±10 %, t ≤ 30 ms L: 0,9 x IN = 2880 A, t = 3 s
2xOF7Z5-M-LC-07-1640-A1-E00-F4	2800	2 x (2 x gG 1000 A)	2 x (3 x gR 800A)	PC73GB69V8 00TF	E4.2 3200 LI	I: 1,5 x IN = 4800 A ±10 %, t ≤ 30 ms L: 1,0 x IN = 3200 A, t = 3 s
2xOF7Z5-M-LC-07-2300-A1-E00-F4	3120	2 x (2 x gG 1000 A)	2 x (3 x gR 800 A)	PC73GB69V8 00TF	E4.2 4000 LI	I: 1,5 x IN = 6000 A ±10 %, t ≤ 30 ms L: 0,9 x IN = 3600 A, t = 3 s
2xOF7Z5-M-LC-07-2300-A1-E00-F4	3270	2 x (2 x gG 1000 A)	2 x (3 x gR 800 A)	PC73GB69V8 00TF	E4.2 4000 LI	I: 1,5 x IN = 6000 A ±10 %, t ≤ 30 ms L: 1,0 x IN = 4000 A, t = 3 s
2xOF7Z5-M-LC-07-2300-A1-E00-F4	3720	2 x (2 x gG 1250 A)	2 x (3 x gR 1000 A)	PC73GB69V1 0CTF	2 x E2.2 2500 LI	I: 1,5 x IN = 3750 A ±10 %, t ≤ 30 ms L: 0,9 x IN = 2250 A, t = 3 s
2xOF7Z5-M-LC-07-2300-A1-E00-F4	4160	2 x (2 x gG 1250 A)	2 x (4 x gR 800 A)	PC73GB69V8 00TF	2 x E2.2 2500 LI	I: 1,5 x IN = 3750 A ±10 %, t ≤ 30 ms L: 1,0 x IN = 2500 A, t = 3 s
3xOF7Z5-M-LC-07-2300-A1-E00-F4	4650	3 x (2 x gG 1000 A)	3 x (3 x gR 800 A)	PC73GB69V8 00TF	2 x E4.2 3200 LI	I: 1,5 x IN = 4800 A ±10 %, t ≤ 30 ms L: 0,9 x IN = 2880 A, t = 3 s

Table 99: AC Fuses and Circuit Breakers for L Filter +AEZ3, Voltage Class A5 - (continued)

Model code	System module: Rated current I_L [A]	IEC gG fuses (at 60 °C (140 °F) ambient, no cooling)	gR fuses (at 60 °C (140 °F) ambient)	Mersen gR fuse type TTF	Recommended circuit breaker type ABB Emax2 (at 60 °C (140 °F) ambient)	Circuit breaker trip unit settings: Ekip DIP/Touch/ Hi-Touch LI
3xOF7Z5-M-LC-07-2300-A1-E00-F4	5200	3 x (2 x gG 1250 A)	3 x (3 x gR 1000 A)	PC73GB69V1 0CTF	2 x E4.2 3200 LI	I: 1,5 x IN = 4800 A ±10 %, t ≤ 30 ms L: 1,0 x IN = 3200 A, t = 3 s
3xOF7Z5-M-LC-07-2300-A1-E00-F4	5550	3 x (2 x gG 1250 A)	3 x (3 x gR 1000 A)	PC73GB69V1 0CTF	2 x E4.2 3200 LI	I: 1,5 x IN = 4800 A ±10 %, t ≤ 30 ms L: 1,0 x IN = 3200 A, t = 3 s
3xOF7Z5-M-LC-07-2300-A1-E00-F4	5930	3 x (2 x gG 1250 A)	3 x (3 x gR 1000 A)	PC73GB69V1 0CTF	2 x E4.2 4000 LI	I: 1,5 x IN = 6000 A ±10 %, t ≤ 30 ms L: 0,9 x IN = 3600 A, t = 3 s
3xOF7Z5-M-LC-07-2300-A1-E00-F4	6450	3 x (2 x gG 1250 A)	3 x (4 x gR 800 A)	PC73GB69V8 00TF	2 x E4.2 4000 LI	I: 1,5 x IN = 6000 A ±10 %, t ≤ 30 ms L: 1,0 x IN = 4000 A, t = 3 s
4xOF7Z5-M-LC-07-2300-A1-E00-F4	6900	4 x (2 x gG 1250 A)	4 x (3 x gR 1000 A)	PC73GB69V1 0CTF	2 x E4.2 4000 LI	I: 1,5 x IN = 6000 A ±10 %, t ≤ 30 ms L: 1,0 x IN = 4000 A, t = 3 s
4xOF7Z5-M-LC-07-2300-A1-E00-F4	7370	4 x (2 x gG 1250 A)	4 x (3 x gR 1000 A)	PC73GB69V1 0CTF	3 x E4.2 3200 LI	I: 1,5 x IN = 4800 A ±10 %, t ≤ 30 ms L: 0,9 x IN = 2880 A, t = 3 s

10.5.16 AC Fuses and Circuit Breakers for L Filter, Voltage Class B5 and 07

The system modules with a mains contactor or a main switch, and a net-side L filter must be protected with branch circuit fuses or a circuit breaker. Check the coordination type in the contactor datasheet with the corresponding gG fuse. The fuse ratings are based on a maximum ambient temperature of 60 °C (140 °F), and when using gR fuses, a minimum airflow of 3 m/s is required. gG fuses do not require additional cooling. Check the selectivity with upstream protective devices. Select the circuit breaker I_{cu}/I_{cw} value according to the supply short-circuit current capability.

Table 100: AC Fuses and Circuit Breakers for L Filter +AEZ3, Voltage Class B5 and 07

Model code	System module: Rated current I_L [A]	IEC gG fuses (at 60 °C (140 °F) ambient, no cooling)	gR fuses (at 60 °C (140 °F) ambient)	Mersen gR fuse type TTF	Recommended circuit breaker type ABB Emax2 (at 60 °C (140 °F) ambient)	Circuit breaker trip unit settings: Ekip DIP/Touch/ Hi-Touch LI
OF7Z5-M-LC-07-400A-A1-E00-F4	236	gG 315 A	gR 800 A	PC73GB69V8 00TF	–	–
OF7Z5-M-LC-07-400A-A1-E00-F4	261	gG 315 A	gR 800 A	PC73GB69V8 00TF	–	–

Table 100: AC Fuses and Circuit Breakers for L Filter +AEZ3, Voltage Class B5 and 07 - (continued)

Model code	System module: Rated current I_L [A]	IEC gG fuses (at 60 °C (140 °F) ambient, no cooling)	gR fuses (at 60 °C (140 °F) ambient)	Mersen gR fuse type TTF	Recom- mended cir- cuit breaker type ABB Emax2 (at 60 °C (140 °F) ambient)	Circuit breaker trip unit settings: Ekip DIP/Touch/ Hi-Touch LI
OF7Z5-M-LC-07-400A-A1-E00-F4	300	gG 400 A	gR 800 A	PC73GB69V8 00TF	–	–
OF7Z5-M-LC-07-400A-A1-E00-F4	325	gG 400 A	gR 1000 A	PC73GB69V1 0CTF	–	–
OF7Z5-M-LC-07-400A-A1-E00-F4	334	gG 400 A	gR 1000 A	PC73GB69V1 0CTF	–	–
OF7Z5-M-LC-07-400A-A1-E00-F4	380	gG 500 A	gR 1000 A	PC73GB69V1 0CTF	–	–
OF7Z5-M-LC-07-1000-A1-E00-F4	425	gG 500 A	2 x gR 800 A	PC73GB69V8 00TF	–	–
OF7Z5-M-LC-07-1000-A1-E00-F4	475	gG 630 A	2 x gR 800 A	PC73GB69V8 00TF	–	–
OF7Z5-M-LC-07-1000-A1-E00-F4	530	gG 630 A	2 x gR 800 A	PC73GB69V8 00TF	–	–
OF7Z5-M-LC-07-1000-A1-E00-F4	595	gG 800 A	2 x gR 800 A	PC73GB69V8 00TF	–	–
OF7Z5-M-LC-07-1000-A1-E00-F4	670	gG 800 A	2 x gR 800 A	PC73GB69V8 00TF	–	–
OF7Z5-M-LC-07-1000-A1-E00-F4	760	gG 1000 A	2 x gR 800 A	PC73GB69V8 00TF	–	–
OF7Z5-M-LC-07-1640-A1-E00-F4	850	gG 1000 A	2 x gR 800 A	PC73GB69V8 00TF	E1.2 1250 LI	I: 1,5 x IN = 1875 A ±10%, t ≤ 30 ms L: 0,8 x IN = 1000 A, t = 3 s
OF7Z5-M-LC-07-1640-A1-E00-F4	945	2 x gG 630 A	2 x gR 800 A	PC73GB69V8 00TF	E1.2 1250 LI	I: 1,5 x IN = 1875 A ±10%, t ≤ 30 ms L: 0,9 x IN = 1125 A, t = 3 s
OF7Z5-M-LC-07-1640-A1-E00-F4	1040	2 x gG 630 A	2 x gR 800 A	PC73GB69V8 00TF	E1.2 1250 LI	I: 1,5 x IN = 1875 A ±10%, t ≤ 30 ms L: 1,0 x IN = 1250 A, t = 3 s
OF7Z5-M-LC-07-1640-A1-E00-F4	1230	2 x gG 800 A	2 x gR 900 A	PC73GB69V9 00TF	E1.2 1600 LI	I: 1,5 x IN = 2400 A ±10%, t ≤ 30 ms L: 0,9 x IN = 1440 A, t = 3 s
OF7Z5-M-LC-07-1640-A1-E00-F4	1325	2 x gG 800 A	2 x gR 1000 A	PC73GB69V1 0CTF	E1.2 1600 LI	I: 1,5 x IN = 2400 A ±10%, t ≤ 30 ms L: 1,0 x IN = 1600 A, t = 3 s

Table 100: AC Fuses and Circuit Breakers for L Filter +AEZ3, Voltage Class B5 and 07 - (continued)

Model code	System module: Rated current I_L [A]	IEC gG fuses (at 60 °C (140 °F) ambient, no cooling)	gR fuses (at 60 °C (140 °F) ambient)	Mersen gR fuse type TTF	Recommended circuit breaker type ABB Emax2 (at 60 °C (140 °F) ambient)	Circuit breaker trip unit settings: Ekip DIP/Touch/Hi-Touch LI
OF7Z5-M-LC-07-1640-A1-E00-F4	1500	2 x gG 1000 A	3 x gR 800 A	PC73GB69V8 00TF	E2.2 2000 LI	I: 1,5 x IN = 3000 A ±10%, t ≤ 30 ms L: 0,9 x IN = 1800 A, t = 3 s
OF7Z5-M-LC-07-2300-A1-E00-F4	1700	2 x gG 1000 A	3 x gR 900 A	PC73GB69V9 00TF	E2.2 2000 LI	I: 1,5 x IN = 3000 A ±10%, t ≤ 30 ms L: 1,0 x IN = 2000 A, t = 3 s
OF7Z5-M-LC-07-2300-A1-E00-F4	1800	3 x gG 800 A	3 x gR 900 A	PC73GB69V9 00TF	E2.2 2500 LI	I: 1,5 x IN = 3750 A ±10%, t ≤ 30 ms L: 0,8 x IN = 2000 A, t = 3 s
OF7Z5-M-LC-07-2300-A1-E00-F4	2000	3 x gG 800 A	3 x gR 1000 A	PC73GB69V1 0TF	E2.2 2500 LI	I: 1,5 x IN = 3750 A ±10%, t ≤ 30 ms L: 1,0 x IN = 2500 A, t = 3 s
OF7Z5-M-LC-07-2300-A1-E00-F4	2250	3 x gG 1000 A	4 x gR 900 A	PC73GB69V9 00TF	E4.2 3200 LI	I: 1,5 x IN = 4800 A ±10%, t ≤ 30 ms L: 0,8 x IN = 2560 A, t = 3 s
2xOF7Z5-M-LC-07-1640-A1-E00-F4	2500	2 x (2 x gG 800 A)	2 x (2 x gR 1000 A)	PC73GB69V1 0CTF	E4.2 3200 LI	I: 1,5 x IN = 4800 A ±10%, t ≤ 30 ms L: 0,9 x IN = 2880 A, t = 3 s
2xOF7Z5-M-LC-07-1640-A1-E00-F4	2650	2 x (2 x gG 800 A)	2 x (2 x gR 1000 A)	PC73GB69V1 0CTF	E4.2 3200 LI	I: 1,5 x IN = 4800 A ±10%, t ≤ 30 ms L: 1,0 x IN = 3200 A, t = 3 s
2xOF7Z5-M-LC-07-1640-A1-E00-F4	2940	2 x (2 x gG 1000 A)	2 x (3 x gR 800 A)	PC73GB69V8 00TF	E4.2 4000 LI	I: 1,5 x IN = 6000 A ±10%, t ≤ 30 ms L: 0,9 x IN = 3600 A, t = 3 s
2xOF7Z5-M-LC-07-2300-A1-E00-F4	3120	2 x (2 x gG 1000 A)	2 x (3 x gR 800 A)	PC73GB69V8 00TF	E4.2 4000 LI	I: 1,5 x IN = 6000 A ±10%, t ≤ 30 ms L: 1,0 x IN = 4000 A, t = 3 s
2xOF7Z5-M-LC-07-2300-A1-E00-F4	3600	2 x (3 x gG 800 A)	2 x (3 x gR 900 A)	PC73GB69V9 00TF	2 x E2.2 2500 LI	I: 1,5 x IN = 3750 A ±10%, t ≤ 30 ms L: 0,9 x IN = 2250 A, t = 3 s
2xOF7Z5-M-LC-07-2300-A1-E00-F4	3900	2 x (3 x gG 800 A)	2 x (3 x gR 1000 A)	PC73GB69V1 0CTF	2 x E2.2 2500 LI	I: 1,5 x IN = 3750 A ±10%, t ≤ 30 ms L: 1,0 x IN = 2500 A, t = 3 s
2xOF7Z5-M-LC-07-2300-A1-E00-F4	4320	2 x (3 x gG 1000 A)	2 x (4 x gR 800 A)	PC73GB69V8 00TF	2 x E4.2 3200 LI	I: 1,5 x IN = 4800 A ±10%, t ≤ 30 ms L: 0,8 x IN = 2560 A, t = 3 s

Table 100: AC Fuses and Circuit Breakers for L Filter +AEZ3, Voltage Class B5 and 07 - (continued)

Model code	System module: Rated current I_L [A]	IEC gG fuses (at 60 °C (140 °F) ambient, no cooling)	gR fuses (at 60 °C (140 °F) ambient)	Mersen gR fuse type TTF	Recommended circuit breaker type ABB Emax2 (at 60 °C (140 °F) ambient)	Circuit breaker trip unit settings: Ekip DIP/Touch/ Hi-Touch LI
4xOF7Z5-M-LC-07-1640-A1-E00-F4	4750	4 x (2 x gG 800 A)	4 x (2 x gR 900 A)	PC73GB69V9 00TF	2 x E4.2 3200 LI	I: 1,5 x IN = 4800 A ±10%, t ≤ 30 ms L: 0,9 x IN = 2880 A, t = 3 s
4xOF7Z5-M-LC-07-1640-A1-E00-F4	5040	4 x (2 x gG 800 A)	4 x (2 x gR 1000 A)	PC73GB69V1 0CTF	2 x E4.2 3200 LI	I: 1,5 x IN = 4800 A ±10%, t ≤ 30 ms L: 0,9 x IN = 2880 A, t = 3 s
4xOF7Z5-M-LC-07-1640-A1-E00-F4	5400	4 x (2 x gG 800 A)	4 x (2 x gR 1000 A)	PC73GB69V1 0CTF	2 x E4.2 3200 LI	I: 1,5 x IN = 4800 A ±10%, t ≤ 30 ms L: 1,0 x IN = 3200 A, t = 3 s
4xOF7Z5-M-LC-07-1640-A1-E00-F4	5750	4 x (2 x gG 1000 A)	4 x (3 x gR 800 A))	PC73GB69V8 00TF	2 x E4.2 4000 LI	I: 1,5 x IN = 6000 A ±10%, t ≤ 30 ms L: 0,9 x IN = 3600 A, t = 3 s

10.5.17 AC Fuses and Circuit Breakers for L Filter, Voltage Class G7

The system modules with a mains contactor or a main switch, and a net-side L filter must be protected with branch circuit fuses or a circuit breaker. Check the coordination type in the contactor datasheet with the corresponding gG fuse. The fuse ratings are based on a maximum ambient temperature of 60 °C (140 °F), and when using gR fuses, a minimum airflow of 3 m/s is required. gG fuses do not require additional cooling. Check the selectivity with upstream protective devices. Select the circuit breaker I_{cu}/I_{cw} value according to the supply short-circuit current capability.

Table 101: AC Fuses and Circuit Breakers for L Filter +AEZ3, Voltage Class G7

Model code	System module: Rated current I_L [A]	IEC gG fuses (at 60 °C (140 °F) ambient, no cooling)	gR fuses (at 60 °C (140 °F) ambient)	Mersen gR fuse type TTF	Recommended circuit breaker type ABB Emax2 (at 60 °C (140 °F) ambient)	Circuit breaker trip unit settings: Ekip DIP/Touch/ Hi-Touch LI
OF7Z5-M-LC-07-1000-A1-E00-F4	760	gG 1000 A	2 x gR 800 A	PC73GB69V8 00TF	–	–
OF7Z5-M-LC-07-1000-A1-E00-F4	970	gG 1250 A	3 x gR 1000 A	PC73GB69V1 0CTF	–	–
OF7Z5-M-LC-07-1640-A1-E00-F4	1500	2 x gG 1000 A	3 x gR 800 A	PC73GB69V8 00TF	–	–
OF7Z5-M-LC-07-2300-A1-E00-F4	1700	2 x gG 1000 A	3 x gR 1000 A	PC73GB69V1 0CTF	–	–

Table 101: AC Fuses and Circuit Breakers for L Filter +AEZ3, Voltage Class G7 - (continued)

Model code	System module: Rated current I _L [A]	IEC gG fuses (at 60 °C (140 °F) ambient, no cooling)	gR fuses (at 60 °C (140 °F) ambient)	Mersen gR fuse type TTF	Recommended circuit breaker type ABB Emax2 (at 60 °C (140 °F) ambient)	Circuit breaker trip unit settings: Ekip DIP/Touch/Hi-Touch LI
OF7Z5-M-LC-07-2300-A1-E00-F4	1900	2 x gG 1250 A	3 x gR 1000 A	PC73GB69V1 OCTF	E2.2 2500 LI	I: 1,5 x I _N = 3750 A ±10%, t ≤ 30 ms L: 0,9 x I _N = 2250 A, t = 3 s
2xOF7Z5-M-LC-07-1640-A1-E00-F4	2450	2 x (2 x gG 800 A)	2 x (2 x gR 1000 A)	PC73GB69V1 OCTF	E4.2 3200 LI	I: 1,5 x I _N = 4800 A ±10%, t ≤ 30 ms L: 0,9 x I _N = 2880 A, t = 3 s
2xOF7Z5-M-LC-07-1640-A1-E00-F4	2800	2 x (2 x gG 1000 A)	2 x (3 x gR 800 A)	PC73GB69V8 00TF	E4.2 3200 LI	I: 1,5 x I _N = 4800 A ±10%, t ≤ 30 ms L: 1,0 x I _N = 3200 A, t = 3 s
2xOF7Z5-M-LC-07-2300-A1-E00-F4	3270	2 x (2 x gG 1000 A)	2 x (3 x gR 800 A)	PC73GB69V8 00TF	E4.2 4000 LI	I: 1,5 x I _N = 6000 A ±10%, t ≤ 30 ms L: 1,0 x I _N = 4000 A, t = 3 s
2xOF7Z5-M-LC-07-2300-A1-E00-F4	3720	2 x (2 x gG 1250 A)	2 x (3 x gR 1000 A)	PC73GB69V1 OCTF	2 x E2.2 2500 LI	I: 1,5 x I _N = 3750 A ±10%, t ≤ 30 ms L: 0,9 x I _N = 2250 A, t = 3 s
2xOF7Z5-M-LC-07-2300-A1-E00-F4	4160	2 x (2 x gG 1250 A)	2 x (4 x gR 800 A)	PC73GB69V8 00TF	2 x E2.2 2500 LI	I: 1,5 x I _N = 3750 A ±10%, t ≤ 30 ms L: 1,0 x I _N = 2500 A, t = 3 s
3xOF7Z5-M-LC-07-2300-A1-E00-F4	4650	3 x (2 x gG 1000 A)	3 x (3 x gR 800 A)	PC73GB69V8 00TF	2 x E4.2 3200 LI	I: 1,5 x I _N = 4800 A ±10%, t ≤ 30 ms L: 0,9 x I _N = 2880 A, t = 3 s
3xOF7Z5-M-LC-07-2300-A1-E00-F4	5550	3 x (2 x gG 1250 A)	3 x (3 x gR 1000 A)	PC73GB69V1 OCTF	2 x E4.2 3200 LI	I: 1,5 x I _N = 4800 A ±10%, t ≤ 30 ms L: 1,0 x I _N = 3200 A, t = 3 s
3xOF7Z5-M-LC-07-2300-A1-E00-F4	6450	3 x (2 x gG 1250 A)	3 x (4 x gR 800 A)	PC73GB69V8 00TF	2 x E4.2 4000 LI	I: 1,5 x I _N = 6000 A ±10%, t ≤ 30 ms L: 1,0 x I _N = 4000 A, t = 3 s
4xOF7Z5-M-LC-07-2300-A1-E00-F4	7370	4 x (2 x gG 1250 A)	4 x (3 x gR 1000 A)	PC73GB69V1 OCTF	3 x E4.2 3200 LI	I: 1,5 x I _N = 4800 A ±10%, t ≤ 30 ms L: 0,9 x I _N = 2880 A, t = 3 s

10.5.18 DC Fuses for SISO Filters 640–1100 V DC, IP00/Open Type

Table 102: DC Fuses for SISO Filters 640–1100 V DC, IP00/Open Type (Eaton/Bussmann)

Model code	Frame	Rated current I _L [A]	Number of fuses	Fuse size	aR fuse part number	Fuse U _n [V]	Fuse I _n [A]
OF7S12-M-LC-07-380-A1-E00-Fx	SILC10L	380	2	3	180D6349	900	1100
OF7S12-M-LC-07-760-A1-E00-Fx	SILC12L	760	2	4	170M7636-UL	1000	1500

Table 102: DC Fuses for SISO Filters 640–1100 V DC, IP00/Open Type (Eaton/Bussmann) - (continued)

Model code	Frame	Rated current I_L [A]	Number of fuses	Fuse size	aR fuse part number	Fuse U_n [V]	Fuse I_n [A]
OF7S12-M-LC-07-1500-A1-E00-Fx	SILC14L	1500	2	4	170M7962-UL	1000	3000
OF7S14-M-LC-07-380-A1-E00-Fx	SILC10L	380	2	3	180D6349	900	1100
OF7S14-M-LC-07-760-A1-E00-Fx	SILC12L	760	2	4	170M7636-UL	1000	1500
OF7S14-M-LC-07-1500-A1-E00-Fx	SILC14L	1500	2	4	170M7962-UL	1000	3000
OF7S02-M-LC-07-730-A1-E00-F4	SOSIN12L	730	2	4	170M7636-UL	1000	1500
OF7S02-M-LC-07-1400-A1-E00-F4	SOSIN14L	1400	2	4	170M7962-UL	1000	3000

10.6 Current Ratings

10.6.1 General Information on the Current Rating Tables

The current rating tables show the ratings of the system modules at relevant voltage ratings. The current rating tables for the liquid-cooled system modules can be found with these links.

- [10.6.2 Current Ratings for AFE 380–440 V AC \(425–650 V DC\)](#)
- [10.6.3 Current Ratings for AFE 440–500 V AC \(425–830 V DC\)](#)
- [10.6.4 Current Ratings for AFE 380–500 V AC \(425–830 V DC\)](#)
- [10.6.5 Current Ratings for AFE 525–690 V AC \(640–1100 V DC\)](#)
- [10.6.6 Current Ratings for GC 380–440 V AC \(425–650 V DC\)](#)
- [10.6.7 Current Ratings for GC 440–500 V AC \(650–830 V DC\)](#)
- [10.6.8 Current Ratings for GC 380–500 V AC \(425–830 V DC\)](#)
- [10.6.9 Current Ratings for GC 525–690 V AC \(640–1100 V DC\)](#)
- [10.6.10 Current Ratings for GC 380–690 V AC \(500–1500 V DC\)](#)
- [10.6.11 Current Ratings for INU 380–440 V AC \(425–650 V DC\)](#)
- [10.6.12 Current Ratings for INU 440–500 V AC \(650–830 V DC\)](#)
- [10.6.13 Current Ratings for INU 380–500 V AC \(425–830 V DC\)](#)
- [10.6.14 Current Ratings for INU 525–690 V AC \(640–1100 V DC\)](#)
- [10.6.15 Current Ratings for DC/DC Converter 425–830 V DC](#)
- [10.6.16 Current Ratings for DC/DC Converter 640–1100 V DC](#)
- [10.6.17 Current Ratings for BCU 380–500 V AC \(425–830 V DC\), Voltage Class A5](#)
- [10.6.18 Current Ratings for BCU 380–500 V AC \(425–830 V DC\), Voltage Class B5](#)
- [10.6.19 Current Ratings for BCU 525–690 V AC \(640–1100 V DC\), Voltage Class O7](#)
- [10.6.20 Current Ratings for the INU with Sine-wave Filter \(+AES1\) \(+AES2\) and LC-filter \(+AEZ1\), 380–500 V AC](#)
- [10.6.21 Current Ratings for the INU with Sine-wave Filter \(+AES1\) \(+AES2\) and LC-filter \(+AEZ\), 600–690 V AC](#)

Table 103: Abbreviations Used in the Rating Tables

Abbreviation	Description
I_N	Nominal current. If the process does not require any overloadability or the process does not include any load variation or margin for overloadability, the dimensioning can be done according to this current.
I_L	Nominal current with low overload (110%). Allows a +10% load variation for 1 minute every 5 minutes.

Table 103: Abbreviations Used in the Rating Tables - (continued)

Abbreviation	Description
I_H	Nominal current with high overload (150%). Allows a +50% load variation for 1 minute every 5 minutes.
I_{peak}	Start current. Available for 3 s at start, then as long as the system module temperature allows. Relevant for inverter modules.
I_{S1}	Short-term current injection available for 1 s. Applicable for the grid converter control mode in grid forming in the event of short-circuit current feed.
I_{S2}	Short-term current injection available for 3 s. Applicable for the grid converter in the grid forming control mode in the event of short-circuit current feed.
P_L	Output power, low overload (INU: motor power, AFE/GC: DC power)
P_H	Output power, high overload (INU: motor power, AFE/GC: DC power)
S_L	Apparent power, low overload

NOTICE

- The short-term current injection (STCI) function requires the Line voltage option OC7V0.

10.6.2 Current Ratings for AFE 380–440 V AC (425–650 V DC)

Table 104: Current Ratings for Active Front-end Module, 380–440 V AC (425–650 V DC)

Model code	Frame ⁽¹⁾	AC current			DC power, 400 V AC mains		Input L Filter size [A]
		I_N [A]	I_L [A]	I_H [A]	P_L [kW]	P_H [kW]	
iC7-60SL3AA5-271AE00F4	AM10L/AR10L	277	271	203	184	144	500
iC7-60SL3AA5-317AE00F4		324	317	238	216	169	500
iC7-60SL3AA5-400AE00F4		409	400	300	272	213	500
iC7-60SL3AA5-460AE00F4		470	460	345	313	244	500
iC7-60SL3AA5-580AE00F4	AM12L/AR12L	593	580	435	394	308	1000
iC7-60SL3AA5-650AE00F4		664	650	488	442	345	1000
iC7-60SL3AA5-730AE00F4		746	730	548	496	388	1000
iC7-60SL3AA5-816AE00F4		833	816	612	555	433	1000
iC7-60SL3AA5-970AE00F4		991	970	728	659	515	1000
iC7-60SL3AA5-1210E00F4	2xAM12L/2xAR12L	1236	1210	908	822	642	1640
iC7-60SL3AA5-1300E00F4		1328	1300	975	883	690	1640
iC7-60SL3AA5-1410E00F4		1440	1410	1058	958	748	1640
iC7-60SL3AA5-1630E00F4		1664	1630	1223	1107	865	1640
iC7-60SL3AA5-1900E00F4		1940	1900	1425	1291	1008	2300
iC7-60SL3AA5-2080E00F4	3xAM12L/3xAR12L	2124	2080	1560	1413	1103	2300
iC7-60SL3AA5-2200E00F4		2246	2200	1650	1494	1167	2300
iC7-60SL3AA5-2450E00F4		2501	2450	1838	1664	1300	2x1640
iC7-60SL3AA5-2800E00F4		2859	2800	2100	1902	1485	2x1640

Table 104: Current Ratings for Active Front-end Module, 380–440 V AC (425–650 V DC) - (continued)

Model code	Frame ⁽¹⁾	AC current			DC power, 400 V AC mains		Input L Filter size [A]
		I _N [A]	I _L [A]	I _H [A]	P _L [kW]	P _H [kW]	
iC7-60SL3AA5-3120E00F4	4xAM12L/4xAR12L	3185	3120	2340	2119	1655	2x2300
iC7-60SL3AA5-3270E00F4		3338	3270	2453	2221	1735	2x2300
iC7-60SL3AA5-3720E00F4		3798	3720	2790	2526	1973	2x2300
iC7-60SL3AA5-4160E00F4	5xAM12L/5xAR12L	4247	4160	3120	2825	2206	2x2300
iC7-60SL3AA5-4650E00F4		4747	4650	3488	3158	2466	3x2300
iC7-60SL3AA5-5200E00F4	6xAM12L/6xAR12L	5309	5200	3900	3531	2758	3x2300
iC7-60SL3AA5-5550E00F4		5666	5550	4163	3769	2944	3x2300
iC7-60SL3AA5-5930E00F4	7xAM12L/7xAR12L	6054	5930	4448	4027	3145	3x2300
iC7-60SL3AA5-6450E00F4		6585	6450	4838	4380	3421	3x2300
iC7-60SL3AA5-6900E00F4	8xAM12L/8xAR12L	7044	6900	5175	4685	3659	4x2300
iC7-60SL3AA5-7370E00F4		7524	7370	5528	5004	3909	4x2300

1) Includes LC-filter with the option +AEZ1 and LCL-filter with the option +AEZ3 (net side L-filter separate module)

10.6.3 Current Ratings for AFE 440–500 V AC (425–830 V DC)

Table 105: Current Ratings for Active Front-end Module, 440–500 V AC (425–830 V DC)

Model code	Frame ⁽¹⁾	AC current			DC power, 500 V AC mains		Input L Filter size [A]
		I _N [A]	I _L [A]	I _H [A]	P _L [kW]	P _H [kW]	
iC7-60SL3AA5-271AE00F4	AM10L/AR10L	277	271	203	230	180	500
iC7-60SL3AA5-317AE00F4		324	317	238	270	211	500
iC7-60SL3AA5-400AE00F4		409	400	300	340	266	500
iC7-60SL3AA5-460AE00F4		445	435	326	370	289	500
iC7-60SL3AA5-580AE00F4	AM12L/AR12L	593	580	435	493	385	1000
iC7-60SL3AA5-650AE00F4		664	650	488	552	432	1000
iC7-60SL3AA5-730AE00F4		746	730	548	620	485	1000
iC7-60SL3AA5-816AE00F4		833	816	612	693	541	1000
iC7-60SL3AA5-970AE00F4		940	920	690	781	610	1000
iC7-60SL3AA5-1210E00F4	2xAM12L/2xAR12L	1236	1210	908	1027	803	1640
iC7-60SL3AA5-1300E00F4		1328	1300	975	1104	862	1640
iC7-60SL3AA5-1410E00F4		1440	1410	1058	1197	935	1640
iC7-60SL3AA5-1630E00F4		1664	1630	1223	1384	1081	1640
iC7-60SL3AA5-1900E00F4		1838	1800	1350	1528	1193	2300
iC7-60SL3AA5-2080E00F4	3xAM12L/3xAR12L	2124	2080	1560	1766	1379	2300
iC7-60SL3AA5-2200E00F4		2246	2200	1650	1868	1459	2300
iC7-60SL3AA5-2450E00F4		2501	2450	1838	2080	1625	2x1640
iC7-60SL3AA5-2800E00F4		2726	2670	2003	2267	1771	2x1640

Table 105: Current Ratings for Active Front-end Module, 440–500 V AC (425–830 V DC) - (continued)

Model code	Frame ⁽¹⁾	AC current			DC power, 500 V AC mains		Input L Filter size [A]
		I _N [A]	I _L [A]	I _H [A]	P _L [kW]	P _H [kW]	
iC7-60SL3AA5-3120E00F4	4xAM12L/4xAR12L	3185	3120	2340	2648	2068	2x2300
iC7-60SL3AA5-3270E00F4		3338	3270	2453	2776	2168	2x2300
iC7-60SL3AA5-3720E00F4		3614	3540	2655	3005	2347	2x2300
iC7-60SL3AA5-4160E00F4	5xAM12L/5xAR12L	4247	4160	3120	3531	2758	2x2300
iC7-60SL3AA5-4650E00F4		4502	4410	3308	3743	2924	3x2300
iC7-60SL3AA5-5200E00F4	6xAM12L/6xAR12L	5002	4900	3675	4159	3248	3x2300
iC7-60SL3AA5-5550E00F4		5390	5280	3960	4482	3500	3x2300
iC7-60SL3AA5-5930E00F4	7xAM12L/7xAR12L	5717	5600	4200	4753	3712	3x2300
iC7-60SL3AA5-6450E00F4		6227	6100	4575	5178	4043	3x2300
iC7-60SL3AA5-6900E00F4	8xAM12L/8xAR12L	6534	6400	4800	5432	4242	4x2300
iC7-60SL3AA5-7370E00F4		7115	6970	5228	5916	4620	4x2300

1) Includes LC-filter with the option +AEZ1 and LCL-filter with the option +AEZ3 (net side L-filter separate module)

10.6.4 Current Ratings for AFE 380–500 V AC (425–830 V DC)

Table 106: Current Ratings for Active Front-end Module, 380–500 V AC (425–830 V DC)

Model code ⁽¹⁾	Frame ⁽²⁾	AC current			DC power, 500 V AC mains ⁽³⁾		Input L Filter size [A] ⁽⁴⁾
		I _N [A]	I _L [A]	I _H [A]	P _L [kW]	P _H [kW]	
iC7-60SL3AB5-261A	AM10L/AR10L	267	261	196	222	167	400
iC7-60SL3AB5-325A		332	325	244	276	208	400
iC7-60SL3AB5-380A		388	380	285	323	242	400
iC7-60SL3AB5-425A	AM12L/AR12L	434	425	318	361	270	1000
iC7-60SL3AB5-475A		485	475	356	404	303	1000
iC7-60SL3AB5-530A		542	530	397	450	337	1000
iC7-60SL3AB5-595A		608	595	446	505	379	1000
iC7-60SL3AB5-670A		684	670	502	569	427	1000
iC7-60SL3AB5-760A		776	760	570	646	484	1000
iC7-60SL3AB5-850A		2 x AM12L/2 x AR12L	868	850	637	722	541
iC7-60SL3AB5-945A	965		945	708	803	601	1640
iC7-60SL3AB5-1040	1062		1040	780	883	662	1640
iC7-60SL3AB5-1230	1256		1230	922	1044	783	1640
iC7-60SL3AB5-1325	1353		1325	993	1125	843	1640
iC7-60SL3AB5-1500	1532		1500	1125	1274	955	1640

Table 106: Current Ratings for Active Front-end Module, 380–500 V AC (425–830 V DC) - (continued)

Model code ⁽¹⁾	Frame ⁽²⁾	AC current			DC power, 500 V AC mains ⁽³⁾		Input L Filter size [A] ⁽⁴⁾
		I _N [A]	I _L [A]	I _H [A]	P _L [kW]	P _H [kW]	
iC7-60SL3AB5-1700	3 x AM12L/3 x AR12L	1736	1700	1275	1443	1083	2300
iC7-60SL3AB5-1800		1838	1800	1350	1528	1146	2300
iC7-60SL3AB5-2000		2042	2000	1500	1698	1274	2300
iC7-60SL3AB5-2250		2297	2250	1687	1910	1432	2300
iC7-60SL3AB5-2500	4 x AM12L/4 x AR12L	2552	2500	1875	2122	1592	2 x 1640
iC7-60SL3AB5-2650		2706	2650	1987	2250	1687	2 x 1640
iC7-60SL3AB5-2940		3002	2940	2205	2496	1872	2 x 1640

1) The hardware has improved transient withstand.

2) AR1xL with option LC Filter +AEZ1 or LCL Filter +AEZ3 (grid side L Filter separate module)

3) $\cos \varphi = 1.00$, efficiency = 98.0%, values calculated at 742 V DC

4) Part of LCL Filter, +AEZ3

10.6.5 Current Ratings for AFE 525–690 V AC (640–1100 V DC)

Table 107: Current Ratings for Active Front-end Module, 525–690 V AC (640–1100 V DC)

Model code	Frame ⁽¹⁾	AC current			DC power, 690 V AC mains ⁽²⁾		Input L Filter size [A] ⁽³⁾
		I _N [A]	I _L [A]	I _H [A]	P _L [kW]	P _H [kW]	
iC7-60SL3A07-236A	AM10L/AR10L	241	236	177	277	208	400
iC7-60SL3A07-300A		307	300	225	352	264	400
iC7-60SL3A07-334A		341	334	250	392	293	400
iC7-60SL3A07-380A		388	380	285	446	334	400
iC7-60SL3A07-425A	AM12L/AR12L	434	425	318	498	373	1000
iC7-60SL3A07-475A		485	475	356	557	417	1000
iC7-60SL3A07-530A		542	530	397	621	465	1000
iC7-60SL3A07-595A		608	595	446	697	523	1000
iC7-60SL3A07-670A		684	670	502	785	588	1000
iC7-60SL3A07-760A		776	760	562	891	668	1000
iC7-60SL3A07-850A		2 x AM12L/2 x AR12L	868	850	637	996	747
iC7-60SL3A07-945A	965		945	708	1107	830	1640
iC7-60SL3A07-1040	1062		1040	780	1219	914	1640
iC7-60SL3A07-1230	1256		1230	922	1441	1080	1640
iC7-60SL3A07-1325	1353		1325	993	1552	1164	1640
iC7-60SL3A07-1500	1532		1500	1125	1757	1318	1640
iC7-60SL3A07-1700	3 x AM12L/3 x AR12L	1736	1700	1275	1992	1494	2300
iC7-60SL3A07-1800		1838	1800	1350	2109	1582	2300
iC7-60SL3A07-2000		2042	2000	1500	2343	1757	2300
iC7-60SL3A07-2250		2297	2250	1687	2636	1976	2300

Table 107: Current Ratings for Active Front-end Module, 525–690 V AC (640–1100 V DC) - (continued)

Model code	Frame ⁽¹⁾	AC current			DC power, 690 V AC mains ⁽²⁾		Input L Filter size [A] ⁽³⁾
		I _N [A]	I _L [A]	I _H [A]	P _L [kW]	P _H [kW]	
iC7-60SL3A07-2500	4 x AM12L/4 x AR12L	2552	2500	1875	2929	2197	2 x 1640
iC7-60SL3A07-2650		2706	2650	1987	3104	2328	2 x 1640
iC7-60SL3A07-2940		3002	2940	2205	3444	2583	2 x 1640
iC7-60SL3A07-3120	5 x AM12L/5 x AR12L	3185	3120	2340	3655	2741	2 x 2300
iC7-60SL3A07-3600		3675	3600	2700	4217	3163	2 x 2300
iC7-60SL3A07-3900	6 x AM12L/6 x AR12L	3982	3900	2925	4568	3426	2 x 2300
iC7-60SL3A07-4320		4410	4320	3240	5060	3795	2 x 2300
iC7-60SL3A07-4750	7 x AM12L/7 x AR12L	4849	4750	3562	5564	4172	4 x 1640
iC7-60SL3A07-5040		5145	5040	3780	5903	4428	4 x 1640
iC7-60SL3A07-5400	8 x AM12L/8 x AR12L	5513	5400	4050	6325	4744	4 x 1640
iC7-60SL3A07-5750		5870	5750	4312	6735	5051	4 x 1640

1) AR1xL with LC Filter +AEZ1, or LCL Filter +AEZ3 (grid side L Filter separate module)

 2) $\cos \varphi = 1.00$, efficiency = 98.0%, values calculated at 1025 V DC

3) Part of LCL Filter, +AEZ3

10.6.6 Current Ratings for GC 380–440 V AC (425–650 V DC)

Table 108: Current Ratings for Grid Converter Module, 380–440 V AC (425–650 V DC)

Model code	Frame ⁽¹⁾	AC current					Power, 400 V AC mains		Input L Filter size [A]
		I _N [A]	I _L [A]	I _H [A]	I _{S1} [A]	I _{S2} [A]	P _L [kW]	S _L [kVA]	
iC7-60SLGCA5-271AE00F4	AM10L/AR10L	277	271	203	448	421	184	188	500
iC7-60SLGCA5-317AE00F4		324	317	238	524	492	216	220	500
iC7-60SLGCA5-400AE00F4		409	400	300	660	620	272	278	500
iC7-60SLGCA5-460AE00F4		470	460	345	759	713	313	319	500
iC7-60SLGCA5-580AE00F4	AM12L/AR12L	593	580	435	957	899	394	402	1000
iC7-60SLGCA5-650AE00F4		664	650	488	1073	1008	442	451	1000
iC7-60SLGCA5-730AE00F4		746	730	548	1205	1132	496	506	1000
iC7-60SLGCA5-816AE00F4		833	816	612	1347	1265	555	566	1000
iC7-60SLGCA5-970AE00F4		991	970	728	1601	1504	659	673	1000
iC7-60SLGCA5-1210E00F4	2xAM12L/2xAR12L	1236	1210	908	1997	1876	822	839	1640
iC7-60SLGCA5-1300E00F4		1328	1300	975	2145	2015	883	901	1640
iC7-60SLGCA5-1410E00F4		1440	1410	1058	2327	2186	958	977	1640
iC7-60SLGCA5-1630E00F4		1664	1630	1223	2690	2527	1107	1130	1640
iC7-60SLGCA5-1900E00F4		1940	1900	1425	3135	2945	1291	1317	2300

Table 108: Current Ratings for Grid Converter Module, 380–440 V AC (425–650 V DC) - (continued)

Model code	Frame ⁽¹⁾	AC current					Power, 400 V AC mains		Input L Filter size [A]
		I _N [A]	I _L [A]	I _H [A]	I _{S1} [A]	I _{S2} [A]	P _L [kW]	S _L [kVA]	
iC7-60SLGCA5-2080E00F4	3xAM12L/3xAR1 2L	2124	2080	1560	3432	3224	1413	1442	2300
iC7-60SLGCA5-2200E00F4		2246	2200	1650	3630	3410	1494	1525	2300
iC7-60SLGCA5-2450E00F4		2501	2450	1838	4043	3798	1664	1698	2x1640
iC7-60SLGCA5-2800E00F4		2859	2800	2100	4620	4340	1902	1940	2x1640
iC7-60SLGCA5-3120E00F4	4xAM12L/4xAR1 2L	3185	3120	2340	5148	4836	2119	2162	2x2300
iC7-60SLGCA5-3270E00F4		3338	3270	2453	5396	5069	2221	2578	2x2300
iC7-60SLGCA5-3720E00F4		3798	3720	2790	6138	5766	2526	2578	2x2300
iC7-60SLGCA5-4160E00F4	5xAM12L/5xAR1 2L	4247	4160	3120	6864	6448	2825	2883	2x2300
iC7-60SLGCA5-4650E00F4		4747	4650	3488	7673	7208	3158	3222	3x2300
iC7-60SLGCA5-5200E00F4	65xAM12L/6xAR1 12L	5309	5200	3900	8580	8060	3531	3603	3x2300
iC7-60SLGCA5-5550E00F4		5666	5550	4163	9158	8603	3769	3846	3x2300
iC7-60SLGCA5-5930E00F4	7xAM12L/7xAR1 2L	6054	5930	4448	9785	9192	4027	4109	3x2300
iC7-60SLGCA5-6450E00F4		6585	6450	4838	10643	9998	4380	4469	3x2300
iC7-60SLGCA5-6900E00F4	8xAM12L/8xAR1 2L	7044	6900	5175	11385	10695	4685	4781	4x2300
iC7-60SLGCA5-7370E00F4		7524	7370	5528	12161	11424	5004	5107	4x2300

1) Includes LC-filter with the option +AEZ1 and LCL-filter with the option +AEZ3 (net side L-filter separate module)

10.6.7 Current Ratings for GC 440–500 V AC (650–830 V DC)

Table 109: Current Ratings for Grid Converter Module, 440–500 V AC (650–830 V DC)

Model code	Frame ⁽¹⁾	AC current					Power, 500 V AC mains		Input L Filter size [A]
		I _N [A]	I _L [A]	I _H [A]	I _{S1} [A]	I _{S2} [A]	P _L [kW]	S _L [kVA]	
iC7-60SLGCA5-271AE00F4	AM10L/AR10L	277	271	203	448	421	230	235	500
iC7-60SLGCA5-317AE00F4		324	317	238	524	492	270	275	500
iC7-60SLGCA5-400AE00F4		409	400	300	660	620	340	347	500
iC7-60SLGCA5-460AE00F4		445	435	326	759	713	370	377	500
iC7-60SLGCA5-580AE00F4	AM12L/AR12L	593	580	435	957	899	493	503	1000
iC7-60SLGCA5-650AE00F4		664	650	488	1073	1008	552	563	1000
iC7-60SLGCA5-730AE00F4		746	730	548	1205	1132	620	633	1000
iC7-60SLGCA5-816AE00F4		833	816	612	1347	1265	693	707	1000
iC7-60SLGCA5-970AE00F4		940	920	690	1601	1504	781	797	1000
iC7-60SLGCA5-1210E00F4	2xAM12L/2xAR1 2L	1236	1210	908	1997	1876	1027	1048	1640
iC7-60SLGCA5-1300E00F4		1328	1300	975	2145	2015	1104	1126	1640
iC7-60SLGCA5-1410E00F4		1440	1410	1058	2327	2186	1197	1222	1640
iC7-60SLGCA5-1630E00F4		1664	1630	1223	2690	2527	1384	1412	1640
iC7-60SLGCA5-1900E00F4		1838	1800	1350	3135	2945	1528	1559	2300

Table 109: Current Ratings for Grid Converter Module, 440–500 V AC (650–830 V DC) - (continued)

Model code	Frame ⁽¹⁾	AC current					Power, 500 V AC mains		Input L Filter size [A]
		I _N [A]	I _L [A]	I _H [A]	I _{S1} [A]	I _{S2} [A]	P _L [kW]	S _L [kVA]	
iC7-60SLGCA5-2080E00F4	3xAM12L/3xAR1 2L	2124	2080	1560	3432	3224	1766	1802	2300
iC7-60SLGCA5-2200E00F4		2246	2200	1650	3630	3410	1868	1906	2300
iC7-60SLGCA5-2450E00F4		2501	2450	1838	4043	3798	2080	2122	2x1640
iC7-60SLGCA5-2800E00F4		2726	2670	2003	4620	4340	2267	2313	2x1640
iC7-60SLGCA5-3120E00F4	4xAM12L/4xAR1 2L	3185	3120	2340	5148	4836	2648	2702	2x2300
iC7-60SLGCA5-3270E00F4		3338	3270	2453	5396	5069	2776	2832	2x2300
iC7-60SLGCA5-3720E00F4		3614	3540	2655	6138	5766	3005	3066	2x2300
iC7-60SLGCA5-4160E00F4	5xAM12L/5xAR1 2L	4247	4160	3120	6864	6448	3531	3603	2x2300
iC7-60SLGCA5-4650E00F4		4502	4410	3308	7673	7208	3743	3820	3x2300
iC7-60SLGCA5-5200E00F4	65xAM12L/6xAR1 12L	5002	4900	3675	8580	8060	4159	4244	3x2300
iC7-60SLGCA5-5550E00F4		5390	5280	3960	9158	8603	4482	4573	3x2300
iC7-60SLGCA5-5930E00F4	7xAM12L/7xAR1 2L	5717	5600	4200	9785	9192	4753	4850	3x2300
iC7-60SLGCA5-6450E00F4		6227	6100	4575	10643	9998	5178	5283	3x2300
iC7-60SLGCA5-6900E00F4	8xAM12L/8xAR1 2L	6834	6400	4800	11385	10695	5432	5543	4x2300
iC7-60SLGCA5-7370E00F4		7115	6970	5228	12161	11424	5916	6037	4x2300

1) Includes LC-filter with the option +AEZ1 and LCL-filter with the option +AEZ3 (net side L-filter separate module)

10.6.8 Current Ratings for GC 380–500 V AC (425–830 V DC)

Table 110: Current Ratings for Grid Converter Module, 380–500 V AC (425–830 V DC)

Model code ⁽¹⁾	Frame ⁽²⁾	AC current ⁽³⁾					Power, 500 V AC mains		Input L Filter size [A] ⁽⁴⁾
		I _N [A]	I _L [A]	I _H [A]	I _{S1} [A]	I _{S2} [A]	P _L [kW]	S _L [kVA]	
iC7-60SLGCB5-261A	AM10L/AR10L	267	261	196	392	365	222	227	400
iC7-60SLGCB5-325A		332	325	244	488	455	276	282	400
iC7-60SLGCB5-380A		388	380	285	570	532	323	330	400
iC7-60SLGCB5-425A	AM12L/AR12L	434	425	318	638	595	361	369	1000
iC7-60SLGCB5-475A		485	475	356	713	665	404	412	1000
iC7-60SLGCB5-530A		542	530	397	795	742	450	459	1000
iC7-60SLGCB5-595A		608	595	446	893	833	505	516	1000
iC7-60SLGCB5-670A		684	670	502	1005	938	569	581	1000
iC7-60SLGCB5-760A		776	760	570	1140	1064	646	659	1000

Table 110: Current Ratings for Grid Converter Module, 380–500 V AC (425–830 V DC) - (continued)

Model code ⁽¹⁾	Frame ⁽²⁾	AC current ⁽³⁾					Power, 500 V AC mains		Input L Filter size [A] ⁽⁴⁾
		I _N [A]	I _L [A]	I _H [A]	I _{S1} [A]	I _{S2} [A]	P _L [kW]	S _L [kVA]	
iC7-60SLGCB5-850A	2 x AM12L/2 x AR12L	868	850	637	1275	1190	722	737	1640
iC7-60SLGCB5-945A		965	945	708	1418	1323	803	819	1640
iC7-60SLGCB5-1040		1062	1040	780	1560	1456	883	901	1640
iC7-60SLGCB5-1230		1256	1230	922	1845	1722	1044	1066	1640
iC7-60SLGCB5-1325		1353	1325	993	1988	1855	1125	1148	1640
iC7-60SLGCB5-1500		1532	1500	1125	2250	2100	1274	1300	1640
iC7-60SLGCB5-1700	3 x AM12L/3 x AR12L	1736	1700	1275	2550	2380	1443	1473	2300
iC7-60SLGCB5-1800		1838	1800	1350	2700	2520	1528	1559	2300
iC7-60SLGCB5-2000		2042	2000	1500	3000	2800	1698	1733	2300
iC7-60SLGCB5-2250		2297	2250	1687	3375	3150	1910	1949	2300
iC7-60SLGCB5-2500	4 x AM12L/4 x AR12L	2552	2500	1875	3750	3500	2122	2166	2 x 1640
iC7-60SLGCB5-2650		2706	2650	1987	3975	3710	2250	2295	2 x 1640
iC7-60SLGCB5-2940		3002	2940	2205	4410	4116	2496	2547	2 x 1640

1) The hardware has improved transient withstand.

2) AR1xL with option LC Filter +AEZ1 or LCL Filter +AEZ3 (grid side L Filter separate module)

3) I_{S1} and I_{S2} are intended for short-circuit current injection in grid-forming operation. The rating is valid when the parameter Paralleling sync. Mode is disabled and the maximum residual voltage of the fault is 30% of nominal at the grid converter terminals. Voltage Measurement OC7V0 is also required.

4) Part of LCL Filter, +AEZ3

10.6.9 Current Ratings for GC 525–690 V AC (640–1100 V DC)

Table 111: Current Ratings for Grid Converter Module, 525–690 V AC (640–1100 V DC)

Model code	Frame ⁽¹⁾	AC current ⁽²⁾					Power, 690 V AC mains		Input L Filter size [A] ⁽³⁾
		I _N [A]	I _L [A]	I _H [A]	I _{S1} [A]	I _{S2} [A]	P _L [kW]	S _L [kVA]	
iC7-60SLGC07-236A	AM10L/AR10L	241	236	177	354	330	277	283	400
iC7-60SLGC07-300A		307	300	225	450	420	352	359	400
iC7-60SLGC07-334A		341	334	250	501	468	392	400	400
iC7-60SLGC07-380A		388	380	285	570	532	446	455	400
iC7-60SLGC07-425A	AM12L/AR12L	434	425	318	638	595	498	508	1000
iC7-60SLGC07-475A		485	475	356	712.5	665	557	568	1000
iC7-60SLGC07-530A		542	530	397	795	742	621	634	1000
iC7-60SLGC07-595A		608	595	446	892.5	833	697	712	1000
iC7-60SLGC07-670A		684	670	502	1005	938	785	801	1000
iC7-60SLGC07-760A		776	760	570	1140	1064	891	909	1000

Table 111: Current Ratings for Grid Converter Module, 525–690 V AC (640–1100 V DC) - (continued)

Model code	Frame ⁽¹⁾	AC current ⁽²⁾					Power, 690 V AC mains		Input L Filter size [A] ⁽³⁾
		I _N [A]	I _L [A]	I _H [A]	I _{S1} [A]	I _{S2} [A]	P _L [kW]	S _L [kVA]	
iC7-60SLGC07-850A	2 x AM12L/2 x AR12L	868	850	637	1275	1190	996	1016	1640
iC7-60SLGC07-945A		965	945	708	1417.5	1323	1107	1130	1640
iC7-60SLGC07-1040		1062	1040	780	1560	1456	1219	1243	1640
iC7-60SLGC07-1230		1256	1230	922	1845	1722	1441	1470	1640
iC7-60SLGC07-1325		1353	1325	993	1988	1855	1552	1584	1640
iC7-60SLGC07-1500		1532	1500	1125	2250	2100	1757	1793	1640
iC7-60SLGC07-1700	3 x AM12L/3 x AR12L	1736	1700	1275	2550	2380	1992	2032	2300
iC7-60SLGC07-1800		1838	1800	1350	2700	2520	2109	2152	2300
iC7-60SLGC07-2000		2042	2000	1500	3000	2800	2343	2391	2300
iC7-60SLGC07-2250		2297	2250	1687	3375	3150	2636	2690	2300
iC7-60SLGC07-2500	4 x AM12L/4 x AR12L	2552	2500	1875	3750	3500	2929	2988	2 x 1640
iC7-60SLGC07-2650		2706	2650	1987	3975	3710	3104	3168	2 x 1640
iC7-60SLGC07-2940		3002	2940	2205	4410	4116	3444	3514	2 x 1640
iC7-60SLGC07-3120	5 x AM12L/5 x AR12L	3185	3120	2340	4680	4368	3655	3729	2 x 2300
iC7-60SLGC07-3600		3675	3600	2700	5400	5040	4217	4303	2 x 2300
iC7-60SLGC07-3900	6 x AM12L/6 x AR12L	3982	3900	2925	5850	5460	4568	4661	2 x 2300
iC7-60SLGC07-4320		4410	4320	3240	6480	6048	5060	5163	2 x 2300
iC7-60SLGC07-4750	7 x AM12L/7 x AR12L	4849	4750	3562	7125	6650	5564	5677	4 x 1640
iC7-60SLGC07-5040		5145	5040	3780	7560	7056	5903	6024	4 x 1640
iC7-60SLGC07-5400	8 x AM12L/8 x AR12L	5513	5400	4050	8100	7560	6325	6454	4 x 1640
iC7-60SLGC07-5750		5870	5750	4312	8625	8050	6735	6872	4 x 1640

1) AR1xL with option LC Filter +AEZ1 or LCL Filter +AEZ3 (grid side L Filter separate module)

2) I_{S1} and I_{S2} are intended for short-circuit current injection in grid-forming operation. The rating is valid when the parameter Paralleling sync. Mode is disabled and the maximum residual voltage of the fault is 30% of nominal at the grid converter terminals. Voltage Measurement OC7V0 is also required.

3) Part of LCL Filter, +AEZ3

10.6.10 Current Ratings for GC 380–690 V AC (500–1500 V DC)

Table 112: Current Ratings for GC 380–690 V AC (500–1500 V DC)

Model code	Frame with option +AEZ1 or +AEZ3 ⁽¹⁾	AC current			DC current	Power, 690 V AC mains		Input L Filter size [A] ⁽²⁾
		I _N [A]	I _L [A]	I _{S2} [A]	I _{N-DC} [A]	P _N [kW]	S _N [kVA]	
iC7-60SLGCG7-760A	AR12L	776	760	1064	897	919	928	1000
iC7-60SLGCG7-970A		1000	970	1358	1156	1184	1196	1000
iC7-60SLGCG7-1500	2 x AR12L	1532	1500	2100	1770	1813	1831	1640
iC7-60SLGCG7-1700		1736	1700	2380	2005	2054	2075	1x 2300
iC7-60SLGCG7-1900		1950	1900	2660	2253	2308	2331	1x 2300

Table 112: Current Ratings for GC 380–690 V AC (500–1500 V DC) - (continued)

Model code	Frame with option +AEZ1 or +AEZ3 ⁽¹⁾	AC current			DC current	Power, 690 V AC mains		Input L Filter size [A] ⁽²⁾
		I _N [A]	I _L [A]	I _{S2} [A]	I _{N-DC} [A]	P _N [kW]	S _N [kVA]	
iC7-60SLGCG7-2450	3 x AR12L	2501	2450	3430	2889	2960	2989	2 x 1640
iC7-60SLGCG7-2800		2900	2800	3920	3350	3432	3466	2 x 1640
iC7-60SLGCG7-3270	4 x AR12L	3338	3270	4578	3855	3950	3990	2 x 2300
iC7-60SLGCG7-3720		3850	3720	5208	4447	4556	4602	2 x 2300
iC7-60SLGCG7-4160	5 x AR12L	4247	4160	5824	4905	5025	5076	3 x 2300
iC7-60SLGCG7-4650		4800	4650	6510	5544	5680	5737	3 x 2300
iC7-60SLGCG7-5550	6 x AR12L	5750	5550	7770	6641	6804	6872	3 x 2300
iC7-60SLGCG7-6450	7 x AR12L	6650	6450	9030	7680	7869	7948	4 x 2300
iC7-60SLGCG7-7370	8 x AR12L	7600	7370	10318	8777	8993	9083	4 x 2300

1) LC Filter +AEZ1, LCL Filter +AEZ3 (grid side L Filter separate module)

2) Part of LCL Filter, +AEZ3

10.6.11 Current Ratings for INU 380–440 V AC (425–650 V DC)

Table 113: Current Ratings for Inverter Module, 380–440 V AC (425–650 V DC)

Model code	Frame ⁽¹⁾	AC current				Motor output power, 400 V AC	
		I _N [A]	I _L [A]	I _H [A]	I _{peak} [A]	P _L [kW]	P _H [kW]
iC7-60SLINA5-245A	IM10L/IR10L	251	245	184	368	132	90
iC7-60SLINA5-302A		309	302	227	454	160	110
iC7-60SLINA5-385A		394	385	289	578	200	132
iC7-60SLINA5-480A		490	480	360	720	250	160
iC7-60SLINA5-520A		531	520	390	780	270	200
iC7-60SLINA5-658A	IM12L/IR12L	672	658	494	988	355	250
iC7-60SLINA5-730A		746	730	548	1096	400	250
iC7-60SLINA5-820A		838	820	615	1230	450	315
iC7-60SLINA5-880A		899	880	660	1320	500	355
iC7-60SLINA5-1000		1021	1000	750	1500	560	400
iC7-60SLINA5-1270	2xIM12L/2xIR12L	1297	1270	953	1906	710	500
iC7-60SLINA5-1460		1491	1460	1095	2190	800	560
iC7-60SLINA5-1630		1664	1630	1223	2446	900	630
iC7-60SLINA5-1760		1797	1760	1320	2640	1000	710
iC7-60SLINA5-1960		2001	1960	1470	2940	1100	800
iC7-60SLINA5-2150	3xIM12L/3xIR12L	2195	2150	1613	3226	1200	900
iC7-60SLINA5-2340		2389	2340	1755	3510	1300	1000
iC7-60SLINA5-2510		2563	2510	1883	3766	1400	1000
iC7-60SLINA5-2880		2940	2880	2160	4320	1600	1200

Table 113: Current Ratings for Inverter Module, 380–440 V AC (425–650 V DC) - (continued)

Model code	Frame ⁽¹⁾	AC current				Motor output power, 400 V AC	
		I _N [A]	I _L [A]	I _H [A]	I _{peak} [A]	P _L [kW]	P _H [kW]
iC7-60SLINA5-3120	4xIM12L/4xIR12L	3185	3120	2340	4680	1700	1300
iC7-60SLINA5-3420		3492	3420	2565	5130	1900	1400
iC7-60SLINA5-3820		3900	3820	2865	5730	2100	1500
iC7-60SLINA5-4140	5xIM12L/5xIR12L	4227	4140	3105	6210	2300	1700
iC7-60SLINA5-4500		4594	4500	3375	6750	2500	1800
iC7-60SLINA5-4750		4849	4750	3563	7126	2600	1900
iC7-60SLINA5-5220	6xIM12L/6xIR12L	5329	5220	3915	7830	2900	2200
iC7-60SLINA5-5680		5799	5680	4260	8520	3100	2300

1) With option +AE_.

10.6.12 Current Ratings for INU 440–500 V AC (650–830 V DC)

Table 114: Current Ratings for Inverter Module, 440–500 V AC (650–830 V DC)

Model code	Frame ⁽¹⁾	AC current				Motor output power, 500 V AC	
		I _N [A]	I _L [A]	I _H [A]	I _{peak} [A]	P _L [kW]	P _H [kW]
iC7-60SLINA5-245A	IM10L/IR10L	251	245	184	368	160	110
iC7-60SLINA5-302A		309	302	227	454	200	132
iC7-60SLINA5-385A		394	385	289	578	250	160
iC7-60SLINA5-480A		490	480	360	720	315	200
iC7-60SLINA5-520A		511	500	375	750	335	220
iC7-60SLINA5-658A	IM12L/IR12L	672	658	494	988	400	270
iC7-60SLINA5-730A		746	730	548	1096	450	315
iC7-60SLINA5-820A		838	820	615	1230	500	355
iC7-60SLINA5-880A		899	880	660	1320	560	400
iC7-60SLINA5-1000		970	950	713	1426	630	450
iC7-60SLINA5-1270	2xIM12L/2xIR12L	1297	1270	953	1906	800	560
iC7-60SLINA5-1460		1491	1460	1095	2190	900	630
iC7-60SLINA5-1630		1664	1630	1223	2446	1100	800
iC7-60SLINA5-1760		1797	1760	1320	2640	1200	900
iC7-60SLINA5-1960		1889	1850	1388	2776	1300	900
iC7-60SLINA5-2150	3xIM12L/3xIR12L	2195	2150	1613	3226	1400	1000
iC7-60SLINA5-2340		2389	2340	1755	3510	1500	1100
iC7-60SLINA5-2510		2563	2510	1883	3766	1600	1200
iC7-60SLINA5-2880		2818	2760	2070	4140	1800	1300

Table 114: Current Ratings for Inverter Module, 440–500 V AC (650–830 V DC) - (continued)

Model code	Frame ⁽¹⁾	AC current				Motor output power, 500 V AC	
		I _N [A]	I _L [A]	I _H [A]	I _{peak} [A]	P _L [kW]	P _H [kW]
iC7-60SLINA5-3120	4xIM12L/4xIR12L	3185	3120	2340	4680	2000	1500
iC7-60SLINA5-3420		3492	3420	2565	5130	2200	1700
iC7-60SLINA5-3820		3726	3650	2738	5476	2400	1800
iC7-60SLINA5-4140	5xIM12L/5xIR12L	4024	3942	2957	5914	2700	1900
iC7-60SLINA5-4500		4329	4240	3180	6360	2900	2100
iC7-60SLINA5-4750		4594	4500	3375	6750	3100	2300
iC7-60SLINA5-5220	6xIM12L/6xIR12L	5002	4900	3675	7350	3300	2500
iC7-60SLINA5-5680		5462	5350	4013	8026	3600	2700

1) With option +AE_.

10.6.13 Current Ratings for INU 380–500 V AC (425–830 V DC)

Table 115: Current Ratings for Inverter Module, 380–500 V AC (425–830 V DC)

Model code ⁽¹⁾	Frame ⁽²⁾	AC current				Motor output power, 500 V AC ⁽³⁾	
		I _N [A]	I _L [A]	I _H [A]	I _{peak} [A]	P _L [kW]	P _H [kW]
iC7-60SLINB5-206A	IM10L/IR10L	211	206	155	310	132	90
iC7-60SLINB5-245A		251	245	184	368	160	110
iC7-60SLINB5-302A		309	302	227	454	200	132
iC7-60SLINB5-385A		394	385	289	578	250	160
iC7-60SLINB5-416A		425	416	312	624	270	200
iC7-60SLINB5-525A	IM12L/IR12L	536	525	393	786	355	250
iC7-60SLINB5-590A		603	590	442	884	400	250
iC7-60SLINB5-650A		664	650	487	974	400	315
iC7-60SLINB5-730A		746	730	547	1094	500	355
iC7-60SLINB5-820A		838	820	615	1230	560	400
iC7-60SLINB5-1060	2 x IM12L/2 x IR12L	1083	1060	795	1590	630	500
iC7-60SLINB5-1230		1256	1230	922	1844	800	630
iC7-60SLINB5-1400		1430	1400	1050	2100	900	710
iC7-60SLINB5-1500		1532	1500	1125	2250	1000	710
iC7-60SLINB5-1640		1675	1640	1230	2460	1100	800
iC7-60SLINB5-1795	3 x IM12L/3 x IR12L	1833	1795	1346	2692	1200	900
iC7-60SLINB5-2080		2124	2080	1560	3120	1400	1000
iC7-60SLINB5-2300		2348	2300	1725	3450	1500	1100
iC7-60SLINB5-2500		2512	2460	1845	3690	1600	1200

Table 115: Current Ratings for Inverter Module, 380–500 V AC (425–830 V DC) - (continued)

Model code ⁽¹⁾	Frame ⁽²⁾	AC current				Motor output power, 500 V AC ⁽³⁾	
		I _N [A]	I _L [A]	I _H [A]	I _{peak} [A]	P _L [kW]	P _H [kW]
iC7-60SLINB5-2830	4 x IM12L/4 x IR12L	2889	2830	2122	4244	2600	1950
iC7-60SLINB5-3050		3114	3050	2287	4574	2800	2000
iC7-60SLINB5-3260		3328	3260	2445	4890	3000	2200

1) The hardware has improved transient withstand.

2) IE1xL with option +AExx.

3) Efficiency = 98.5%.

10.6.14 Current Ratings for INU 525–690 V AC (640–1100 V DC)

Table 116: Current Ratings for Inverter Module 525–690 V AC (640–1100 V DC)

Model code	Frame ⁽¹⁾	AC current				Motor output power, 690 V AC ⁽²⁾	
		I _N [A]	I _L [A]	I _H [A]	I _{peak} [A]	P _L [kW]	P _H [kW]
iC7-60SLIN07-170A	IM10L/IR10L	174	170	127	254	160	90
iC7-60SLIN07-208A		213	208	156	312	200	132
iC7-60SLIN07-261A		267	261	195	390	250	160
iC7-60SLIN07-325A		332	325	243	486	315	200
iC7-60SLIN07-365A		373	365	273	546	355	250
iC7-60SLIN07-416A		425	416	312	624	400	250
iC7-60SLIN07-465A	IM12L/IR12L	475	465	348	696	450	315
iC7-60SLIN07-525A		536	525	393	786	500	355
iC7-60SLIN07-590A		603	590	442	884	560	400
iC7-60SLIN07-650A		664	650	487	974	630	450
iC7-60SLIN07-730A		746	730	547	1094	710	500
iC7-60SLIN07-820A		838	820	615	1230	800	560
iC7-60SLIN07-945A	2 x IM12L/2 x IR12L	965	945	708	1416	900	630
iC7-60SLIN07-1060		1083	1060	795	1590	1000	710
iC7-60SLIN07-1230		1256	1230	922	1844	1100	800
iC7-60SLIN07-1400		1430	1400	1050	2100	1300	900
iC7-60SLIN07-1500		1532	1500	1125	2250	1400	1000
iC7-60SLIN07-1640		1675	1640	1230	2460	1500	1100
iC7-60SLIN07-1795	3 x IM12L/3 x IR12L	1833	1795	1346	2692	1700	1250
iC7-60SLIN07-2080		2124	2080	1560	3120	1900	1400
iC7-60SLIN07-2300		2348	2300	1725	3450	2100	1600
iC7-60SLIN07-2500		2512	2460	1845	3690	2300	1750

Table 116: Current Ratings for Inverter Module 525–690 V AC (640–1100 V DC) - (continued)

Model code	Frame ⁽¹⁾	AC current				Motor output power, 690 V AC ⁽²⁾	
		I _N [A]	I _L [A]	I _H [A]	I _{peak} [A]	P _L [kW]	P _H [kW]
iC7-60SLIN07-2830	4 x IM12L/4 x IR12L	2889	2830	2122	4244	2600	1950
iC7-60SLIN07-3050		3114	3050	2287	4574	2800	2000
iC7-60SLIN07-3260		3328	3260	2445	4890	3000	2200
iC7-60SLIN07-3500	5 x IM12L/5 x IR12L	3573	3500	2625	5250	3300	2400
iC7-60SLIN07-4035		4119	4035	3026	6052	3800	2800
iC7-60SLIN07-4400	6 x IM12L/6 x IR12L	4492	4400	3300	6600	4100	3100
iC7-60SLIN07-4850		4951	4850	3637	7274	4500	3500
iC7-60SLIN07-5300	7 x IM12L/7 x IR12L	5411	5300	3975	7950	5000	3700
iC7-60SLIN07-5600		5717	5600	4200	8400	5300	4000
iC7-60SLIN07-6100	8 x IM12L/8 x IR12L	6227	6100	4575	9150	5700	4300
iC7-60SLIN07-6400		6534	6400	4800	9600	6000	4600

1) IR1xL with option +AExx.

2) efficiency = 98.5%

10.6.15 Current Ratings for DC/DC Converter 425–830 V DC

Table 117: Current Ratings for DC/DC Converter 425–830 V DC

Model code ⁽¹⁾	Frame ⁽²⁾	DC-bus current	DC source current ⁽³⁾			DC power, 700...250 V DC source
		I _{N-DC} [A]	I _N [A]	I _L [A]	I _H [A]	P _{L-typ} [kW]
iC7-60SLDCB5-300A	DM10L/DR10L	307	307	300	225	210...75
iC7-60SLDCB5-360A		368	368	360	270	252...90
iC7-60SLDCB5-420A		429	429	420	315	294...105
iC7-60SLDCB5-480A		490	490	480	360	336...120
iC7-60SLDCB5-570A		582	582	570	428	399...143
iC7-60SLDCB5-720A	DM12L/DR12L	735	735	720	540	504...180
iC7-60SLDCB5-840A		858	858	840	630	588...210
iC7-60SLDCB5-960A		980	980	960	720	672...240
iC7-60SLDCB5-1080		1103	1103	1080	810	756...270
iC7-60SLDCB5-1200		1225	1225	1200	900	840...300
iC7-60SLDCB5-1440	2 x DM12L/2 x DR12L	1470	1470	1440	1080	1008...360
iC7-60SLDCB5-1680		1715	1715	1680	1260	1176...420
iC7-60SLDCB5-1920		1960	1960	1920	1440	1344...480
iC7-60SLDCB5-2160		2205	2205	2160	1620	1512...540
iC7-60SLDCB5-2400		2450	2450	2400	1800	1680...600

Table 117: Current Ratings for DC/DC Converter 425–830 V DC - (continued)

Model code ⁽¹⁾	Frame ⁽²⁾	DC-bus current	DC source current ⁽³⁾			DC power, 700...250 V DC source
		I _{N-DC} [A]	I _N [A]	I _L [A]	I _H [A]	P _{L-typ} [kW]
iC7-60SLDCB5-2880	3 x DM12L/3 x DR12L	2940	2940	2880	2160	2016...720
iC7-60SLDCB5-3240		3308	3308	3240	2430	2268...810
iC7-60SLDCB5-3600		3675	3675	3600	2700	2520...900

1) The ratings are valid at 800 V DC.

2) DR1xL with option +AExx.

3) Sum of 3 phases.

10.6.16 Current Ratings for DC/DC Converter 640–1100 V DC

Table 118: Current Ratings for DC/DC Converter 640–1100 V DC

Model code ⁽¹⁾	Frame ⁽²⁾	DC-bus current	DC source current ⁽³⁾			DC power, 1000...250 V DC source
		I _{N-DC} [A]	I _N [A]	I _L [A]	I _H [A]	P _{L-typ} [kW]
iC7-60SLDC07-300A	DM10L/DR10L	307	307	300	225	300...75
iC7-60SLDC07-360A		368	368	360	270	360...90
iC7-60SLDC07-420A		429	429	420	315	420...105
iC7-60SLDC07-480A		490	490	480	360	480...120
iC7-60SLDC07-570A		582	582	570	428	570...142
iC7-60SLDC07-720A	DM12L/DR12L	735	735	720	540	720...180
iC7-60SLDC07-840A		858	858	840	630	840...210
iC7-60SLDC07-960A		980	980	960	720	960...240
iC7-60SLDC07-1080		1103	1103	1080	810	1080...270
iC7-60SLDC07-1200		1225	1225	1200	900	1200...300
iC7-60SLDC07-1440	2xDM12L/2xDR12L	1470	1470	1440	1080	1440...360
iC7-60SLDC07-1680		1715	1715	1680	1260	1680...420
iC7-60SLDC07-1920		1960	1960	1920	1440	1920...480
iC7-60SLDC07-2160		2205	2205	2160	1620	2160...540
iC7-60SLDC07-2400		2450	2450	2400	1800	2400...600
iC7-60SLDC07-2880	3xDM12L/3xDR12L	2940	2940	2880	2160	2880...720
iC7-60SLDC07-3240		3308	3308	3240	2430	3240...810
iC7-60SLDC07-3600		3675	3675	3600	2700	3600...900

1) The ratings are valid at 1025 V DC.

2) DR1xL with option +AExx.

3) Sum of 3 phases.

10.6.17 Current Ratings for BCU 380–500 V AC (425–830 V DC), Voltage Class A5

Table 119: Current Ratings for Brake Chopper Unit, 380–500 V AC (425–830 V DC)

Model code	Frame ⁽¹⁾	Ratings, continuous operation								Ratings, heavy duty (200% IH) ⁽²⁾			
		I _{L=DC}	I _L	P _{typ} (380 V AC network)	R _{min} ⁽³⁾ Rated minimum resistance	P _{typ} (480 V AC network)	R _{min} ⁽³⁾ Rated minimum resistance	P _{typ} (500 V AC network)	R _{min} ⁽³⁾ Rated minimum resistance	I _{H=DC}	I _H	P _{typ}	R _{min} ⁽³⁾ Rated minimum resistance
		[A]	[A]	600 V DC [kW]	600 V DC [Ω]	760 V DC [kW]	760 V DC [Ω]	800 V DC [kW]	800 V DC [Ω]	[A]	[A]	800 V DC [kW]	800 V DC [Ω]
iC7-60SLBRA5-206A	BM10L/ BR10L	206	206	124	1.94	157	2.46	165	2.59	309	309	248	1.73
iC7-60SLBRA5-385A		385	385	231	1.04	293	1.32	308	1.39	578	578	462	0.92
iC7-60SLBRA5-520A		520	520	312	0.77	396	0.97	416	1.03	780	780	624	0.68
iC7-60SLBRA5-658A	BM12L/ BR12L	658	658	395	0.61	501	0.77	527	0.81	987	987	790	0.54
iC7-60SLBRA5-820A		820	820	492	0.49	624	0.62	656	0.65	1230	1230	984	0.43
iC7-60SLBRA5-1000		1000	1000	600	0.40	760	0.51	800	0.53	1500	1500	1200	0.36
iC7-60SLBRA5-1270	2xBM12L/ 2xBR12L	1270	1270	762	0.31	966	0.40	1016	0.42	1905	1905	1524	0.28
iC7-60SLBRA5-1630		1630	1630	978	0.25	1239	0.31	1304	0.33	2445	2445	1956	0.22
iC7-60SLBRA5-1960		1960	1960	1176	0.20	1490	0.26	1568	0.27	2940	2940	2352	0.18

1) With option +AE_.

 2) 3 s I_H peak followed by a ramp-down to 0 in 7 s.

 3) R_{min} = Resistance of a single resistor in wye-connection.

10.6.18 Current Ratings for BCU 380–500 V AC (425–830 V DC), Voltage Class B5

Table 120: Current Ratings for Brake Chopper Unit, 380–500 V AC (425–830 V DC)

Model code	Frame ⁽¹⁾	Ratings, continuous operation								Ratings, heavy duty (200% IH) ⁽²⁾			
		I _{L=DC}	I _L	P _{typ} (380 V AC network)	R _{min} ⁽³⁾ Rated minimum resistance	P _{typ} (480 V AC network)	R _{min} ⁽³⁾ Rated minimum resistance	P _{typ} (500 V AC network)	R _{min} ⁽³⁾ Rated minimum resistance	I _{H=DC}	I _H	P _{typ}	R _{min} ⁽³⁾ Rated minimum resistance
		[A]	[A]	600 V DC [kW]	600 V DC [Ω]	760 V DC [kW]	760 V DC [Ω]	800 V DC [kW]	800 V DC [Ω]	[A]	[A]	800 V DC [kW]	800 V DC [Ω]
iC7-60SLBRB5-170A	BM10L/ BR10L	170	170	102	2.35	130	2.98	136	3.14	255	255	204	2.09
iC7-60SLBRB5-261A		261	261	157	1.53	199	1.94	209	2.04	392	392	314	1.36
iC7-60SLBRB5-416A		416	416	250	0.96	317	1.22	333	1.28	624	624	500	0.85

Table 120: Current Ratings for Brake Chopper Unit, 380–500 V AC (425–830 V DC) - (continued)

Model code	Frame ⁽¹⁾	Ratings, continuous operation								Ratings, heavy duty (200% I _H) ⁽²⁾			
		I _{L=DC}	I _L	P _{typ} (380 V AC network)	R _{min} ⁽³⁾ Rated minimum resistance	P _{typ} (480 V AC network)	R _{min} ⁽³⁾ Rated minimum resistance	P _{typ} (500 V AC network)	R _{min} ⁽³⁾ Rated minimum resistance	I _{H=DC}	I _H	P _{typ}	R _{min} ⁽³⁾ Rated minimum resistance
		[A]	[A]	600 V DC [kW]	600 V DC [Ω]	760 V DC [kW]	760 V DC [Ω]	800 V DC [kW]	800 V DC [Ω]	[A]	[A]	800 V DC [kW]	800 V DC [Ω]
iC7-60SLBRB5-525A	BM12L/ BR12L	525	525	315	0.76	399	0.97	420	1.02	788	788	630	0.68
iC7-60SLBRB5-650A		650	650	390	0.62	494	0.78	520	0.82	975	975	780	0.55
iC7-60SLBRB5-820A		820	820	492	0.49	624	0.62	656	0.65	1230	1230	984	0.43
iC7-60SLBRB5-1060	2xBM12L/ 2xBR12L	1060	1060	636	0.38	806	0.48	848	0.50	1590	1590	1272	0.34
iC7-60SLBRB5-1400		1400	1400	840	0.29	1064	0.36	1120	0.38	2100	2100	1680	0.25
iC7-60SLBRB5-1640		1640	1640	984	0.24	1247	0.31	1312	0.33	2460	2460	1968	0.22

1) With option +AE_.

 2) 3 s I_H peak followed by a ramp-down to 0 in 7 s.

 3) R_{min} = Resistance of a single resistor in wye-connection.

10.6.19 Current Ratings for BCU 525–690 V AC (640–1100 V DC), Voltage Class 07

Table 121: Current Ratings for Brake Chopper Unit, 525–690 V AC (640–1100 V DC)

Model code	Frame ⁽¹⁾	Ratings, continuous operation								Ratings, heavy duty (200% I _H) ⁽²⁾			
		I _{L=DC}	I _L	P _{typ} (525 V AC network)	R _{min} ⁽³⁾ Rated minimum resistance	P _{typ} (600 V AC network)	R _{min} ⁽³⁾ Rated minimum resistance	P _{typ} (690 V AC network)	R _{min} ⁽³⁾ Rated minimum resistance	I _{H=DC}	I _H	P _{typ}	R _{min} ⁽³⁾ Rated minimum resistance
		[A]	[A]	840 V DC [kW]	840 V DC [Ω]	950 V DC [kW]	950 V DC [Ω]	1100 V DC [kW]	1100 V DC [Ω]	[A]	[A]	1100 V DC [kW]	1100 V DC [Ω]
iC7-60SLBR07-170A	BM10L/ BR10L	170	170	143	3.29	162	3.73	187	4.31	255	255	281	2.88
iC7-60SLBR07-261A		261	261	220	2.15	248	2.43	288	2.81	392	392	431	1.87
iC7-60SLBR07-416A		416	416	350	1.35	396	1.52	458	1.76	624	624	687	1.18
iC7-60SLBR07-525A	BM12L/ BR12L	525	525	441	1.07	499	1.21	578	1.40	788	788	867	0.93
iC7-60SLBR07-650A		650	650	546	0.86	618	0.97	715	1.13	975	975	1073	0.75
iC7-60SLBR07-820A		820	820	689	0.68	779	0.77	902	0.89	1230	1230	1353	0.60

Table 121: Current Ratings for Brake Chopper Unit, 525–690 V AC (640–1100 V DC) - (continued)

Model code	Frame ⁽¹⁾	Ratings, continuous operation								Ratings, heavy duty (200% I _H) ⁽²⁾			
		I _{L=DC}	I _L	P _{typ} (525 V AC network)	R _{min} ⁽³⁾ Rated minimum resistance	P _{typ} (600 V AC network)	R _{min} ⁽³⁾ Rated minimum resistance	P _{typ} (690 V AC network)	R _{min} ⁽³⁾ Rated minimum resistance	I _{H=DC}	I _H	P _{typ}	R _{min} ⁽³⁾ Rated minimum resistance
		[A]	[A]	840 V DC [kW]	840 V DC [Ω]	950 V DC [kW]	950 V DC [Ω]	1100 V DC [kW]	1100 V DC [Ω]	[A]	[A]	1100 V DC [kW]	1100 V DC [Ω]
iC7-60SLBR07-1060	2xBM12L/ 2xBR12L	1060	1060	891	0.53	1007	0.60	1166	0.69	1590	1590	1749	0.46
iC7-60SLBR07-1400		1400	1400	1176	0.40	1330	0.45	1540	0.52	2100	2100	2310	0.35
iC7-60SLBR07-1640		1640	1640	1378	0.34	1558	0.39	1804	0.45	2460	2460	2706	0.30

1) With option +AE___.

 2) 3 s I_H peak followed by a ramp-down to 0 in 7 s.

 3) R_{min} = Resistance of a single resistor in wye-connection.

10.6.20 Current Ratings for the INU with Sine-wave Filter (+AES1) (+AES2) and LC-filter (+AEZ1), 380–500 V AC

Table 122: Current Ratings for the INU with Sine-wave Filter (+AES1) (+AES2) and LC-filter (+AEZ1), 380–500 V AC

Model code	IP00 ⁽¹⁾	I _{N-DC} [A]	P _{N-DC} [kW] (DC to motor)	I _{L-DC} [A]	P _{L-DC} [kW]	I _N [A]	I _L [A]	I _{L-OL} [A]	Overload [%/I _L]	I _{L-peak} (3s) [A]	I _{L-peak} (3s) [%/I _H]	f _{sw} rated, DPWM/SVPWM [kHz]	P _{typ} 500 V [kW]
iC7-60SLINB5-525A	IM12L/ IR12L	577	389	565	381	536	525	578	110	786	200	'8/5	355
iC7-60SLINB5-590A		651	439	638	430	603	590	649	110	884	200	'8/5	400
iC7-60SLINB5-650A		731	493	716	483	672	658	724	110	974	200	'8/5	450
iC7-60SLINB5-730A		812	548	796	537	746	730	803	110	1094	200	'8/5	500
iC7-60SLINB5-1060	2xIM12L /IR12L	1153	778	1129	762	1083	1060	1166	110	1590	200	'8/5	710
iC7-60SLINB5-1230		1300	877	1273	859	1256	1230	1353	110	1844	200	'8/5	800
iC7-60SLINB5-1400		1461	986	1432	966	1430	1400	1540	110	2100	200	'8/5	900
iC7-60SLINB5-1795	3xIM12L /IR12L	1949	1315	1909	1288	1833	1795	1975	110	2692	200	'8/5	1200
iC7-60SLINB5-2080	3xIM12L /IR12L	2273	1534	2227	1503	2124	2080	2288	110	3120	200	'8/5	1400
iC7-60SLINB5-2830	4xIM12L /IR12L	3085	2082	3023	2040	2889	2830	3113	110	4244	200	'8/5	1900

 1) IR12L with +AE_{xx}

Table 123: Current Derating Factor, in % of Rated Current as a Function of Output Frequency

Output frequency [Hz]	Current derating factor [%]
0.01	61
0.1	62
1	67
2	72
5	82
10	90
15	94
20	96
30	99
40	100
50	100
70	100
100	100
150	100
200	100
250	100
300	100

10.6.21 Current Ratings for the INU with Sine-wave Filter (+AES1) (+AES2) and LC-filter (+AEZ), 600–690 V AC

Table 124: Current Ratings for the INU with Sine-wave Filter (+AES1) (+AES2) and LC-filter (+AEZ), 600–690 V AC

Model code	IP00 ⁽¹⁾	I _{N-DC} [A]	P _{N-DC} [kW] (DC to motor)	I _{L-DC} [A]	P _{L-DC} [kW]	I _N [A]	I _L [A]	I _{L-OL} [A]	Over- load [%/IL]	I _{L- peak (3 s)} [A]	I _{L- peak (3 s)} [%/IH]	f _{sw} rated, DPWM/ SFAVM [kHz]	P _{typ,r} 690 V [kW]
iC7-60SLIN07-465A	IM12L/ IR12L	530	493	519	483	475	465	512	110	696	200	'8/5	450
iC7-60SLIN07-525A		589	548	577	537	536	525	578	110	786	200	'8/5	500
iC7-60SLIN07-590A		660	614	646	601	603	590	649	110	884	200	'8/5	560
iC7-60SLIN07-650A		742	691	727	677	664	650	715	110	974	200	'8/5	630
iC7-60SLIN07-730A		836	778	819	762	746	730	803	110	1094	200	'8/5	710
iC7-60SLIN07-945A	2xIM12L /IR12L	1059	986	1038	966	965	945	1040	110	1416	200	'8/5	900
iC7-60SLIN07-1060		1177	1096	1153	1074	1083	1060	1166	110	1590	200	'8/5	1000
iC7-60SLIN07-1230		1295	1206	1268	1181	1256	1230	1353	110	1844	200	'8/5	1100
iC7-60SLIN07-1400		1530	1425	1499	1396	1430	1400	1540	110	2100	200	'8/5	1300
iC7-60SLIN07-1795	3xIM12L /IR12L	2000	1863	1960	1825	1833	1795	1975	110	2692	200	'8/5	1700
iC7-60SLIN07-2080		2236	2082	2191	2040	2124	2080	2288	110	3120	200	'8/5	1900

Table 124: Current Ratings for the INU with Sine-wave Filter (+AES1) (+AES2) and LC-filter (+AEZ), 600–690 V AC - (continued)

Model code	IP00 ⁽¹⁾	I _{N-DC} [A]	P _{N-DC} [kW] (DC to motor)	I _{L-DC} [A]	P _{L-DC} [kW]	I _N [A]	I _L [A]	I _{L-OL} [A]	Over-load [%/IL]	I _{L-peak} (3 s) [A]	I _{L-peak} (3 s) [%/IH]	f _{sw} rated, DPWM/ SFAVM [kHz]	P _{typ} 690 V [kW]
iC7-60SLIN07-2830	4xIM12L /IR12L	3059	2849	2997	2791	2889	2830	3113	110	4244	200	'8/5	2600
iC7-60SLIN07-3500	5xIM12L /IR12L	3882	3616	3803	3542	3573	3500	3850	110	5250	200	'8/5	3300
iC7-60SLIN07-4400	6xIM12L /IR12L	4823	4492	4725	4401	4492	4400	4840	110	6600	200	'8/5	4100

1) IR12L with +AExx

Table 125: Current Derating Factor, in % of Rated Current as a Function of Output Frequency

Output frequency [Hz]	Current derating factor [%]	Notes
0.01	61	–
0.1	62	–
1	67	–
2	72	–
5	82	–
10	90	–
15	94	–
20	96	–
30	99	–
40	100	–
50	100	–
70	100	–
100	100	–
150	100	The maximum ambient temperature in the system module for the filter capacitor is 57 °C (135 °F). ⁽¹⁾
200	100	The maximum ambient temperature in the system module for the filter capacitor is 50 °C (122 °F). ⁽¹⁾
250	100	The maximum ambient temperature in the system module for the filter capacitor is 44 °C (111 °F). ⁽¹⁾
300	100	The maximum ambient temperature in the system module for the filter capacitor is 37 °C (99 °F). ⁽¹⁾

1) These ambient derating values apply for 690 V output voltage. With lower output voltages, the ambient temperature can be increased by approximately 5 °C (41 °F) per 50 V voltage decrease.

10.7 Power Losses

10.7.1 List of Power Loss Information

The power loss tables for the liquid-cooled system modules can be found with these links.

- [10.7.2 Power Losses of AFE and GC Modules 400 V AC, 594 V DC \(425–830 V DC\)](#)
- [10.7.3 Power Losses of AFE and GC Modules 400 V AC, 594 V DC \(425–830 V DC\) with options +AEZ1 and +AEZ3](#)
- [10.7.4 Power Losses of AFE and GC Modules 500 V AC, 742 V DC \(425–830 V DC\)](#)
- [10.7.5 Power Losses of AFE and GC Modules 500 V AC, 742 V DC \(425–830 V DC\) with options +AEZ1 and +AEZ3](#)
- [10.7.6 Power Losses of AFE and GC Modules, Voltage Class 07](#)
- [10.7.7 Power Losses of AFE and GC Modules, Voltage Class 07, with +AEZ1 and +AEZ3](#)
- [10.7.8 Power Losses of AFE and GC Modules, Voltage Class B5](#)
- [10.7.9 Power Losses of AFE and GC Modules, Voltage Class B5, with +AEZ1 and +AEZ3](#)
- [10.7.11 Power Losses of GC Modules, Voltage Class G7, with +AEZ1](#)
- [10.7.12 Power Losses of INU Modules with +AEU1, Voltage Class 07, Motor Cable Maximum Length 150 m \(492 ft\)](#)
- [10.7.13 Power Losses of INU Modules with +AEU1, Voltage Class 07, Motor Cable Maximum Length 50 m \(164 ft\)](#)
- [10.7.14 Power Losses of INU modules 400 V AC \(594 V DC\), Voltage class A5, Modulator Type 1](#)
- [10.7.15 Power Losses of INU modules 400 V AC \(594 V DC\), Voltage class A5, Modulator Type 2](#)
- [10.7.16 Power Losses of INU modules 500 V AC \(460–800 V DC\), Voltage class A5, Modulator Type 1](#)
- [10.7.17 Power Losses of INU modules 500 V AC \(460–800 V DC\), Voltage class A5, Modulator Type 2](#)
- [10.7.18 Power Losses of INU Modules without Options, Voltage Class 07, Modulator Type 1 – SVPWM](#)
- [10.7.19 Power Losses of INU Modules without Options, Voltage Class 07, Modulator Type 6 – Optimized](#)
- [10.7.20 Power Losses of INU Modules with +AEU1, Voltage Class B5, Motor Cable Maximum Length 150 m \(492 ft\)](#)
- [10.7.21 Power Losses of INU Modules with +AEU1, Voltage Class B5, Motor Cable Maximum Length 50 m \(164 ft\)](#)
- [10.7.22 Power Losses of INU Modules without Options, Voltage Class B5, Modulator Type 1 – SVPWM](#)
- [10.7.23 Power Losses of INU Modules without Options, Voltage Class B5, Modulator Type 6 – Optimized](#)
- [10.7.24 Power Losses of INU Modules with +AES1, Voltage Class 07](#)
- [10.7.25 Power Losses of INU Modules with +AES1, Voltage Class B5](#)
- [10.7.26 Power Losses of DC/DC Converter Modules, Voltage Class 07](#)
- [10.7.27 Power Losses of DC/DC Converter Modules, Voltage Class B5](#)
- [10.7.28 Power Losses of BCU Modules, Voltage Class B5, 500 V AC, 800 V DC](#)
- [10.7.29 Power Losses of BCU Modules, Voltage Class 07, 690 V AC, 1100 V DC](#)

10.7.2 Power Losses of AFE and GC Modules 400 V AC, 594 V DC (425–830 V DC)

- The specifications for the values in the table
 - AFE or GC module
 - 400 V AC, 594 V DC (425–830 V DC)
 - DC voltage 594 V DC
 - Modulator type 4
 - The default modulator type for grid converters is type 5, which results in slightly lower losses than given in the table.

Table 126: Power Losses for AFE and GC Modules

Product code	Frame	Rated current $I_{L(1/5)}$ [A]	System module		+AKFX ⁽¹⁾
			Power loss to liquid [kW]	Power loss to air [kW]	Power loss to air [kW]
iC7-60SL3AA5-271A	AM10L	271	1.83	0.02	0.05
iC7-60SL3AA5-317A	AM10L	317	2.21	0.02	0.06
iC7-60SL3AA5-400A	AM10L	400	2.98	0.03	0.07
iC7-60SL3AA5-460A	AM10L	460	3.61	0.04	0.09
iC7-60SL3AA5-520A	AM12L	520	3.06	0.03	0.08
iC7-60SL3AA5-580A	AM12L	580	3.49	0.03	0.10
iC7-60SL3AA5-650A	AM12L	650	4.01	0.04	0.12
iC7-60SL3AA5-730A	AM12L	730	4.64	0.05	0.15
iC7-60SL3AA5-816A	AM12L	816	5.36	0.05	0.13
C7-60SL3AA5-970A	AM12L	970	6.78	0.07	0.20
iC7-60SL3AA5-1040	2xAM12L	1040	6.12	0.06	0.15
iC7-60SL3AA5-1210	2xAM12L	1210	7.34	0.07	0.22
iC7-60SL3AA5-1300	2xAM12L	1300	8.02	0.08	0.22
iC7-60SL3AA5-1410	2xAM12L	1410	8.88	0.09	0.27
iC7-60SL3AA5-1630	2xAM12L	1630	10.71	0.11	0.26
iC7-60SL3AA5-1900	2xAM12L	1900	13.17	0.13	0.36
iC7-60SL3AA5-2080	3xAM12L	2080	13.05	0.13	0.38
iC7-60SL3AA5-2200	3xAM12L	2200	14.01	0.14	0.42
iC7-60SL3AA5-2450	3xAM12L	2450	16.11	0.16	0.38
iC7-60SL3AA5-2800	3xAM12L	2800	19.28	0.19	0.50
iC7-60SL3AA5-3120	4xAM12L	3120	20.22	0.20	0.63
iC7-60SL3AA5-3270	4xAM12L	3270	21.51	0.22	0.51
iC7-60SL3AA5-3720	4xAM12L	3720	25.58	0.26	0.67
iC7-60SL3AA5-4160	5xAM12L	4160	27.52	0.28	0.64
iC7-60SL3AA5-4650	5xAM12L	4650	31.98	0.32	0.84
iC7-60SL3AA5-5200	6xAM12L	5200	34.86	0.35	0.89
iC7-60SL3AA5-5550	6xAM12L	5550	38.09	0.38	0.97
iC7-60SL3AA5-5930	7xAM12L	5930	39.46	0.39	0.94
iC7-60SL3AA5-6450	7xAM12L	6450	46.20	0.46	1.11
iC7-60SL3AA5-6900	8xAM12L	6900	46.22	0.46	1.13
iC7-60SL3AA5-7370	8xAM12L	7370	50.50	0.51	1.29

1) DC fuses

10.7.3 Power Losses of AFE and GC Modules 400 V AC, 594 V DC (425–830 V DC) with options +AEZ1 and +AEZ3

- The specifications for the values in the table
 - AFE or GC module
 - 400 V AC, 594 V DC (425–830 V DC)
 - DC voltage 594 V DC
 - Modulator type 4
 - The default modulator type for grid converters is type 5, which results in slightly lower losses than given in the table.

Table 127: Power Losses for AFE and GC Modules

Product code	Frame	Rated current $I_{L(1/5)}$ [A]	System module ⁽¹⁾		System module ⁽²⁾		+AKFX ⁽³⁾	Standby loss ⁽⁴⁾ [kW]
			Power loss to liquid [kW]	Power loss to air [kW]	Power loss to liquid [kW]	Power loss to air [kW]	Power loss to air [kW]	
iC7-60SL3AA5-271A	AR10L	271	2.2	0.12	2.3	0.12	0.05	0.06
iC7-60SL3AA5-317A	AR10L	317	2.7	0.16	2.8	0.16	0.06	0.06
iC7-60SL3AA5-400A	AR10L	400	3.7	0.18	4.0	0.18	0.07	0.06
iC7-60SL3AA5-460A	AR10L	460	4.6	0.25	5.0	0.25	0.09	0.06
iC7-60SL3AA5-520A	AR12L	520	3.8	0.15	3.9	0.15	0.08	0.11
iC7-60SL3AA5-580A	AR12L	580	4.3	0.19	4.5	0.19	0.10	0.11
iC7-60SL3AA5-650A	AR12L	650	5.1	0.24	5.3	0.24	0.12	0.11
iC7-60SL3AA5-730A	AR12L	730	5.9	0.31	6.2	0.31	0.15	0.11
iC7-60SL3AA5-816A	AR12L	816	7.0	0.29	7.3	0.29	0.13	0.11
C7-60SL3AA5-970A	AR12L	970	9.1	0.38	9.7	0.38	0.20	0.11
iC7-60SL3AA5-1040	2xAR12L	1040	7.5	0.30	8.0	0.30	0.15	0.22
iC7-60SL3AA5-1210	2xAR12L	1210	9.1	0.42	9.8	0.42	0.22	0.22
iC7-60SL3AA5-1300	2xAR12L	1300	10.1	0.49	10.9	0.49	0.22	0.22
iC7-60SL3AA5-1410	2xAR12L	1410	11.3	0.60	12.3	0.60	0.27	0.22
iC7-60SL3AA5-1630	2xAR12L	1630	13.9	0.56	15.2	0.56	0.26	0.22
iC7-60SL3AA5-1900	2xAR12L	1900	17.6	0.74	19.3	0.74	0.36	0.22
iC7-60SL3AA5-2080	3xAR12L	2080	16.6	0.86	18.00	0.86	0.38	0.33
iC7-60SL3AA5-2200	3xAR12L	2200	18.0	0.94	19.31	0.94	0.42	0.33
iC7-60SL3AA5-2450	3xAR12L	2450	20.9	0.84	22.27	0.84	0.38	0.33
iC7-60SL3AA5-2800	3xAR12L	2800	25.7	1.08	27.53	1.08	0.50	0.33
iC7-60SL3AA5-3120	4xAR12L	3120	26.1	1.42	28.3	1.42	0.63	0.44
iC7-60SL3AA5-3270	4xAR12L	3270	28.0	1.11	30.4	1.11	0.51	0.44
iC7-60SL3AA5-3720	4xAR12L	3720	34.1	1.43	37.4	1.43	0.67	0.44
iC7-60SL3AA5-4160	5xAR12L	4160	35.9	1.44	40.1	1.44	0.64	0.55
iC7-60SL3AA5-4650	5xAR12L	4650	42.6	1.75	46.0	1.75	0.84	0.55

Table 127: Power Losses for AFE and GC Modules - (continued)

Product code	Frame	Rated current $I_{L(1/5)}$ [A]	System module ⁽¹⁾		System module ⁽²⁾		+AKFX ⁽³⁾	Standby loss ⁽⁴⁾
			Power loss to liquid [kW]	Power loss to air [kW]	Power loss to liquid [kW]	Power loss to air [kW]	Power loss to air [kW]	[kW]
iC7-60SL3AA5-5200	6xAR12L	5200	45.9	1.83	50.1	1.83	0.89	0.66
iC7-60SL3AA5-5550	6xAR12L	5550	50.7	2.14	55.6	2.14	0.97	0.66
iC7-60SL3AA5-5930	7xAR12L	5930	51.7	2.12	57.6	2.12	0.94	0.77
iC7-60SL3AA5-6450	7xAR12L	6450	60.9	2.51	68.0	2.51	1.11	0.77
iC7-60SL3AA5-6900	8xAR12L	6900	60.8	2.44	67.0	2.44	1.13	0.88
iC7-60SL3AA5-7370	8xAR12L	7370	67.2	2.85	74.3	2.85	1.29	0.88

1) LC-filter in integration unit (option +AEZ1).

2) LC-filter in integration unit + L-filter (option +AEZ3).

3) DC fuses.

4) System module and +AEZ1.

10.7.4 Power Losses of AFE and GC Modules 500 V AC, 742 V DC (425–830 V DC)

- The specifications for the values in the table
 - AFE or GC module
 - 500 V AC, 742 V DC (425–830 V DC)
 - DC voltage 742 V DC
 - Modulator type 4
 - The default modulator type for grid converters is type 5, which results in slightly lower losses than given in the table.

Table 128: Power Losses for AFE and GC Modules

Product code	Frame	Rated current $I_{L(1/5)}$ [A]	System module		+AKFX ⁽¹⁾
			Power loss to liquid [kW]	Power loss to air [kW]	Power loss to air [kW]
iC7-60SL3AA5-271A	AM10L	271	2.21	0.02	0.05
iC7-60SL3AA5-317A	AM10L	317	2.68	0.03	0.06
iC7-60SL3AA5-400A	AM10L	400	3.64	0.04	0.07
iC7-60SL3AA5-460A	AM10L	435	4.09	0.04	0.09
iC7-60SL3AA5-520A	AM12L	520	3.60	0.04	0.08
iC7-60SL3AA5-580A	AM12L	580	4.11	0.04	0.10
iC7-60SL3AA5-650A	AM12L	650	4.73	0.05	0.12
iC7-60SL3AA5-730A	AM12L	730	5.49	0.05	0.15
iC7-60SL3AA5-816A	AM12L	816	6.35	0.06	0.13
C7-60SL3AA5-970A	AM12L	920	7.49	0.07	0.20
iC7-60SL3AA5-1040	2xAM12L	1040	7.20	0.07	0.15
iC7-60SL3AA5-1210	2xAM12L	1210	8.66	0.09	0.22
iC7-60SL3AA5-1300	2xAM12L	1300	9.46	0.09	0.22

Table 128: Power Losses for AFE and GC Modules - (continued)

Product code	Frame	Rated current $I_{L(1/5)}$ [A]	System module		+AKFX ⁽¹⁾
			Power loss to liquid [kW]	Power loss to air [kW]	Power loss to air [kW]
iC7-60SL3AA5-1410	2xAM12L	1410	10.49	0.10	0.27
iC7-60SL3AA5-1630	2xAM12L	1630	12.69	0.13	0.26
iC7-60SL3AA5-1900	2xAM12L	1800	14.53	0.15	0.36
iC7-60SL3AA5-2080	3xAM12L	2080	15.41	0.15	0.38
iC7-60SL3AA5-2200	3xAM12L	2200	16.56	0.17	0.42
iC7-60SL3AA5-2450	3xAM12L	2450	19.08	0.19	0.38
iC7-60SL3AA5-2800	3xAM12L	2670	21.46	0.21	0.50
iC7-60SL3AA5-3120	4xAM12L	3120	23.94	0.24	0.63
iC7-60SL3AA5-3270	4xAM12L	3270	25.48	0.25	0.51
iC7-60SL3AA5-3720	4xAM12L	3540	28.39	0.28	0.67
iC7-60SL3AA5-4160	5xAM12L	4160	32.61	0.33	0.64
iC7-60SL3AA5-4650	5xAM12L	4410	35.32	0.35	0.84
iC7-60SL3AA5-5200	6xAM12L	4900	38.16	0.38	0.89
iC7-60SL3AA5-5550	6xAM12L	5280	42.25	0.42	0.97
iC7-60SL3AA5-5930	7xAM12L	5600	43.32	0.43	0.94
iC7-60SL3AA5-6450	7xAM12L	6100	48.63	0.49	1.11
iC7-60SL3AA5-6900	8xAM12L	6400	49.51	0.50	1.13
iC7-60SL3AA5-7370	8xAM12L	6970	55.56	0.56	1.29

1) DC fuses

10.7.5 Power Losses of AFE and GC Modules 500 V AC, 742 V DC (425–830 V DC) with options +AEZ1 and +AEZ3

- The specifications for the values in the table
 - AFE or GC module
 - 500 V AC, 742 V DC (425–830 V DC)
 - DC voltage 742 V DC
 - Modulator type 4
 - The default modulator type for grid converters is type 5, which results in slightly lower losses than given in the table.

Table 129: Power Losses for AFE and GC Modules

Product code	Frame	Rated current $I_{L(1/5)}$ [A]	System module ⁽¹⁾		System module ⁽²⁾		+AKFX ⁽³⁾	Standby loss ⁽⁴⁾ [kW]
			Power loss to liquid [kW]	Power loss to air [kW]	Power loss to liquid [kW]	Power loss to air [kW]	Power loss to air [kW]	
iC7-60SL3AA5-271A	AR10L	271	2.6	0.08	2.7	0.08	0.05	0.06
iC7-60SL3AA5-317A	AR10L	317	3.2	0.11	3.4	0.11	0.06	0.06

Table 129: Power Losses for AFE and GC Modules - (continued)

Product code	Frame	Rated current $I_{L(1/5)}$ [A]	System module ⁽¹⁾		System module ⁽²⁾		+AKFX ⁽³⁾	Standby loss ⁽⁴⁾ [kW]
			Power loss to liquid [kW]	Power loss to air [kW]	Power loss to liquid [kW]	Power loss to air [kW]	Power loss to air [kW]	
iC7-60SL3AA5-400A	AR10L	400	4.4	0.11	4.7	0.11	0.07	0.06
iC7-60SL3AA5-460A	AR10L	435	5.0	0.15	5.3	0.15	0.09	0.06
iC7-60SL3AA5-520A	AR12L	520	4.4	0.16	4.6	0.16	0.08	0.13
iC7-60SL3AA5-580A	AR12L	580	5.0	0.19	5.2	0.19	0.10	0.13
iC7-60SL3AA5-650A	AR12L	650	5.9	0.25	6.1	0.25	0.12	0.13
iC7-60SL3AA5-730A	AR12L	730	6.9	0.32	7.2	0.32	0.15	0.13
iC7-60SL3AA5-816A	AR12L	816	8.1	0.29	8.4	0.29	0.13	0.13
C7-60SL3AA5-970A	AR12L	920	9.7	0.39	10.2	0.39	0.20	0.13
iC7-60SL3AA5-1040	2xAR12L	1040	8.8	0.31	9.3	0.31	0.15	0.26
iC7-60SL3AA5-1210	2xAR12L	1210	10.6	0.43	11.3	0.43	0.22	0.26
iC7-60SL3AA5-1300	2xAR12L	1300	11.7	0.50	12.5	0.50	0.22	0.26
iC7-60SL3AA5-1410	2xAR12L	1410	13.1	0.62	14.1	0.62	0.27	0.26
iC7-60SL3AA5-1630	2xAR12L	1630	16.1	0.58	17.4	0.58	0.26	0.26
iC7-60SL3AA5-1900	2xAR12L	1800	18.7	0.76	20.3	0.76	0.36	0.26
iC7-60SL3AA5-2080	3xAR12L	2080	19.3	0.88	21.35	0.88	0.38	0.38
iC7-60SL3AA5-2200	3xAR12L	2200	20.8	0.96	23.18	0.96	0.42	0.38
iC7-60SL3AA5-2450	3xAR12L	2450	24.2	0.87	25.57	0.87	0.38	0.38
iC7-60SL3AA5-2800	3xAR12L	2670	27.6	1.10	29.27	1.10	0.50	0.38
iC7-60SL3AA5-3120	4xAR12L	3120	30.2	1.45	32.4	1.45	0.63	0.51
iC7-60SL3AA5-3270	4xAR12L	3270	32.4	1.15	34.8	1.15	0.51	0.51
iC7-60SL3AA5-3720	4xAR12L	3540	36.5	1.45	39.4	1.45	0.67	0.51
iC7-60SL3AA5-4160	5xAR12L	4160	41.5	1.49	45.7	1.49	0.64	0.64
iC7-60SL3AA5-4650	5xAR12L	4410	45.4	1.78	48.4	1.78	0.84	0.64
iC7-60SL3AA5-5200	6xAR12L	4900	48.4	1.86	52.1	1.86	0.89	0.77
iC7-60SL3AA5-5550	6xAR12L	5280	54.3	2.18	58.6	2.18	0.97	0.77
iC7-60SL3AA5-5930	7xAR12L	5600	54.8	2.16	59.7	2.16	0.94	0.90
iC7-60SL3AA5-6450	7xAR12L	6100	62.4	2.54	68.4	2.54	1.11	0.90
iC7-60SL3AA5-6900	8xAR12L	6400	62.6	2.48	67.3	2.48	1.13	1.02
iC7-60SL3AA5-7370	8xAR12L	6970	71.3	2.90	77.0	2.90	1.29	1.02

1) LC-filter in integration unit (option +AEZ1).

2) LC-filter in integration unit + L-filter (option +AEZ3).

3) DC fuses.

4) System module and +AEZ1.

10.7.6 Power Losses of AFE and GC Modules, Voltage Class 07

- The specifications for the values in the table
 - AFE or GC module
 - 525–690 V AC (640–1100 V DC)
 - DC voltage 1025 V DC
 - Modulator type 4
 - The default modulator type for grid converters is type 5, which results in slightly lower losses than given in the table.

Table 130: Power Losses for AFE and GC Modules

Model code	Frame	Rated current $I_{L(1/5)}$ [A]	System module		+AKFX ⁽¹⁾	Standby loss [kW]
			Power loss to liquid [kW]	Power loss to air [kW]	Power loss to air [kW]	
iC7-60SL3A07-236A	AM10L	236	3.29	0.03	0.04	0.07
iC7-60SL3A07-300A		300	4.44	0.04	0.06	0.07
iC7-60SL3A07-334A		334	5.13	0.05	0.06	0.07
iC7-60SL3A07-380A		380	6.16	0.06	0.09	0.07
iC7-60SL3A07-425A	AM12L	425	5.82	0.06	0.05	0.13
iC7-60SL3A07-475A		475	6.63	0.07	0.07	0.13
iC7-60SL3A07-530A		530	7.58	0.08	0.09	0.13
iC7-60SL3A07-595A		595	8.79	0.09	0.11	0.13
iC7-60SL3A07-670A		670	10.31	0.10	0.12	0.13
iC7-60SL3A07-760A		760	12.32	0.12	0.16	0.13
iC7-60SL3A07-850A	2 x AM12L	850	11.64	0.12	0.10	0.26
iC7-60SL3A07-945A		945	13.19	0.13	0.12	0.26
iC7-60SL3A07-1040		1040	14.81	0.15	0.15	0.26
iC7-60SL3A07-1230		1230	18.36	0.19	0.19	0.26
iC7-60SL3A07-1325		1325	20.30	0.21	0.23	0.26
iC7-60SL3A07-1500		1500	24.17	0.24	0.30	0.26
iC7-60SL3A07-1700	3 x AM12L	1700	24.76	0.25	0.29	0.39
iC7-60SL3A07-1800		1800	26.67	0.27	0.29	0.39
iC7-60SL3A07-2000		2000	30.71	0.31	0.34	0.39
iC7-60SL3A07-2250		2250	36.25	0.37	0.43	0.39
iC7-60SL3A07-2500	4 x AM12L	2500	37.52	0.38	0.38	0.52
iC7-60SL3A07-2650		2650	40.60	0.41	0.46	0.52
iC7-60SL3A07-2940		2940	46.95	0.47	0.55	0.52
iC7-60SL3A07-3120	5 x AM12L	3120	46.80	0.47	0.48	0.66
iC7-60SL3A07-3600		3600	56.99	0.58	0.66	0.66
iC7-60SL3A07-3900	6 x AM12L	3900	59.34	0.60	0.65	0.79
iC7-60SL3A07-4320		4320	68.38	0.69	0.79	0.79

Table 130: Power Losses for AFE and GC Modules - (continued)

Model code	Frame	Rated current $I_{L(1/5)}$ [A]	System module		+AKFX ⁽¹⁾	Standby loss [kW]
			Power loss to liquid [kW]	Power loss to air [kW]	Power loss to air [kW]	
iC7-60SL3A07-4750	7 x AM12L	4750	73.43	0.74	0.80	0.92
iC7-60SL3A07-5040		5040	79.78	0.81	0.92	0.92
iC7-60SL3A07-5400	8 x AM12L	5400	83.30	0.84	0.91	1.05
iC7-60SL3A07-5750		5750	90.97	0.92	1.06	1.05

1) DC fuses

10.7.7 Power Losses of AFE and GC Modules, Voltage Class 07, with +AEZ1 and +AEZ3

- The specifications for the values in the table
 - AFE or GC module
 - 525–690 V AC (640–1100 V DC)
 - DC voltage 1025 V DC
 - Modulator type 4
 - The default modulator type for grid converters is type 5, which results in slightly lower losses than given in the table.
 - Option +AEZ1 or +AEZ3

Table 131: Power Losses for AFE and GC Modules with Options +AEZ1 and +AEZ3

Model code	Frame	Rated current $I_{L(1/5)}$ [A]	System module and +AEZ1 ⁽¹⁾		System module and +AEZ3 ⁽²⁾		+AKFX ⁽³⁾	Standby loss, sys- tem mod- ule and +AEZ1 [kW]
			Power loss to liquid [kW]	Power loss to air [kW]	Power loss to liquid [kW]	Power loss to air [kW]	Power loss to air [kW]	
iC7-60SL3A07-236A	AR10L	236	4.1	0.19	4.2	0.27	0.04	0.07
iC7-60SL3A07-300A		300	5.6	0.27	5.8	0.40	0.06	0.07
iC7-60SL3A07-334A		334	6.5	0.31	6.7	0.47	0.06	0.07
iC7-60SL3A07-380A		380	7.8	0.38	8.1	0.59	0.09	0.07
iC7-60SL3A07-425A	AR12L	425	6.6	0.25	6.7	0.32	0.05	0.14
iC7-60SL3A07-475A		475	7.5	0.29	7.7	0.38	0.07	0.14
iC7-60SL3A07-530A		530	8.6	0.35	8.8	0.46	0.09	0.14
iC7-60SL3A07-595A		595	10.0	0.40	10.2	0.54	0.11	0.14
iC7-60SL3A07-670A		670	11.7	0.52	12.0	0.69	0.12	0.14
iC7-60SL3A07-760A		760	14.0	0.61	14.3	0.84	0.16	0.14
iC7-60SL3A07-850A	2 x AR12L	850	13.3	0.48	13.6	0.71	0.10	0.27
iC7-60SL3A07-945A		945	15.1	0.57	15.5	0.85	0.12	0.27
iC7-60SL3A07-1040		1040	16.9	0.69	17.4	1.03	0.15	0.27
iC7-60SL3A07-1230		1230	20.9	0.89	21.6	1.35	0.19	0.27
iC7-60SL3A07-1325		1325	23.2	1.00	24.0	1.55	0.23	0.27
iC7-60SL3A07-1500		1500	27.6	1.23	28.7	1.95	0.30	0.27

Table 131: Power Losses for AFE and GC Modules with Options +AEZ1 and +AEZ3 - (continued)

Model code	Frame	Rated current $I_{L(1/5)}$ [A]	System module and +AEZ1 ⁽¹⁾		System module and +AEZ3 ⁽²⁾		+AKFX ⁽³⁾	Standby loss, system module and +AEZ1 [kW]
			Power loss to liquid [kW]	Power loss to air [kW]	Power loss to liquid [kW]	Power loss to air [kW]	Power loss to air [kW]	
iC7-60SL3A07-1700	3 x AR12L	1700	28.2	1.14	28.91	1.60	0.29	0.41
iC7-60SL3A07-1800		1800	30.4	1.25	31.15	1.75	0.29	0.41
iC7-60SL3A07-2000		2000	35.0	1.51	35.96	2.13	0.34	0.41
iC7-60SL3A07-2250		2250	41.4	1.83	42.55	2.61	0.43	0.41
iC7-60SL3A07-2500	4 x AR12L	2500	42.8	1.79	44.2	2.76	0.38	0.55
iC7-60SL3A07-2650		2650	46.3	1.96	48.0	3.07	0.46	0.55
iC7-60SL3A07-2940		2940	53.6	2.33	55.7	3.71	0.55	0.55
iC7-60SL3A07-3120	5 x AR12L	3120	53.4	2.25	55.7	3.80	0.48	0.69
iC7-60SL3A07-3600		3600	65.0	2.82	68.0	4.81	0.66	0.69
iC7-60SL3A07-3900	6 x AR12L	3900	67.7	2.85	70.0	4.44	0.65	0.82
iC7-60SL3A07-4320		4320	78.0	3.24	81.0	5.24	0.79	0.82
iC7-60SL3A07-4750	7 x AR12L	4750	83.7	3.63	86.8	5.69	0.80	0.96
iC7-60SL3A07-5040		5040	91.0	3.96	94.7	6.40	0.92	0.96
iC7-60SL3A07-5400	8 x AR12L	5400	95.0	4.13	98.5	6.44	0.91	1.10
iC7-60SL3A07-5750		5750	103.8	4.51	107.8	7.16	1.06	1.10

1) System module and the LC Filter and AC fuses in the integration unit

2) System module and the LC Filter and AC fuses in the integration unit and the L Filter

3) DC fuses

10.7.8 Power Losses of AFE and GC Modules, Voltage Class B5

- The specifications for the values in the table
 - AFE or GC module
 - 380–500 V AC (465–800 V DC)
 - DC voltage 594 V DC
 - Modulator type 4
 - The default modulator type for grid converters is type 5, which results in slightly lower losses than given in the table.

Table 132: Power Losses for AFE and GC Modules

Model code	Frame	Rated current $I_{L(1/5)}$ [A]	System module		+AKFX ⁽¹⁾	Standby loss [kW]
			Power loss to liquid [kW]	Power loss to air [kW]	Power loss to air [kW]	
iC7-60SL3AB5-261A	AM10L	261	2.50	0.03	0.05	0.04
iC7-60SL3AB5-325A		325	3.28	0.03	0.07	0.04
iC7-60SL3AB5-380A		380	4.02	0.04	0.09	0.04

Table 132: Power Losses for AFE and GC Modules - (continued)

Model code	Frame	Rated current $I_{L(1/5)}$ [A]	System module		+AKFX ⁽¹⁾	Standby loss [kW]
			Power loss to liquid [kW]	Power loss to air [kW]	Power loss to air [kW]	
iC7-60SL3AB5-425A	AM12L	425	3.96	0.04	0.05	0.07
iC7-60SL3AB5-475A		475	4.49	0.05	0.07	0.07
iC7-60SL3AB5-530A		530	5.10	0.05	0.09	0.07
iC7-60SL3AB5-595A		595	5.87	0.06	0.11	0.07
iC7-60SL3AB5-670A		670	6.81	0.07	0.12	0.07
iC7-60SL3AB5-760A		760	8.04	0.08	0.16	0.07
iC7-60SL3AB5-850A	2 x AM12L	850	7.92	0.08	0.10	0.14
iC7-60SL3AB5-945A		945	8.93	0.09	0.12	0.14
iC7-60SL3AB5-1040		1040	9.97	0.10	0.15	0.14
iC7-60SL3AB5-1230		1230	12.23	0.12	0.19	0.14
iC7-60SL3AB5-1325		1325	13.44	0.14	0.23	0.14
iC7-60SL3AB5-1500		1500	15.80	0.16	0.30	0.14
iC7-60SL3AB5-1700	3 x AM12L	1700	16.58	0.17	0.29	0.22
iC7-60SL3AB5-1800		1800	17.79	0.18	0.29	0.22
iC7-60SL3AB5-2000		2000	20.31	0.21	0.34	0.22
iC7-60SL3AB5-2250		2250	23.70	0.24	0.43	0.22
iC7-60SL3AB5-2500	4 x AM12L	2500	24.95	0.25	0.38	0.29
iC7-60SL3AB5-2650		2650	26.87	0.27	0.46	0.29
iC7-60SL3AB5-2940		2940	30.76	0.31	0.55	0.29

1) DC fuses

10.7.9 Power Losses of AFE and GC Modules, Voltage Class B5, with +AEZ1 and +AEZ3

- The specifications for the values in the table
 - AFE or GC module
 - 380–500 V AC (465–800 V DC)
 - DC voltage 594 V DC
 - Modulator type 4
 - The default modulator type for grid converters is type 5, which results in slightly lower losses than given in the table.
 - Option +AEZ1 or +AEZ3

Table 133: Power Losses for AFE and GC Modules with Options +AEZ1 and +AEZ3

Model code	Frame	Rated current $I_{L(1/5)}$ [A]	System module and +AEZ1 ⁽¹⁾		System module and +AEZ3 ⁽²⁾		+AKFX ⁽³⁾	Standby loss, system module and +AEZ1 [kW]
			Power loss to liquid [kW]	Power loss to air [kW]	Power loss to liquid [kW]	Power loss to air [kW]	Power loss to air [kW]	
iC7-60SL3AB5-261A	AR10L	261	3.12	0.20	3.26	0.29	0.05	0.04
iC7-60SL3AB5-325A		325	4.22	0.25	4.43	0.38	0.07	0.04
iC7-60SL3AB5-380A		380	5.33	0.32	5.62	0.51	0.09	0.04
iC7-60SL3AB5-425A	AR12L	425	4.47	0.19	4.58	0.26	0.05	0.07
iC7-60SL3AB5-475A		475	5.11	0.23	5.24	0.32	0.07	0.07
iC7-60SL3AB5-530A		530	5.84	0.29	6.01	0.40	0.09	0.07
iC7-60SL3AB5-595A		595	6.75	0.34	6.95	0.47	0.11	0.07
iC7-60SL3AB5-670A		670	7.95	0.45	8.21	0.63	0.12	0.07
iC7-60SL3AB5-760A		760	9.48	0.54	9.81	0.76	0.16	0.07
iC7-60SL3AB5-850A		2 x AR12L	850	8.94	0.37	9.26	0.59	0.10
iC7-60SL3AB5-945A	945		10.16	0.46	10.57	0.73	0.12	0.15
iC7-60SL3AB5-1040	1040		11.41	0.57	11.91	0.91	0.15	0.15
iC7-60SL3AB5-1230	1230		14.12	0.75	14.81	1.21	0.19	0.15
iC7-60SL3AB5-1325	1325		15.65	0.86	16.47	1.41	0.23	0.15
iC7-60SL3AB5-1500	1500		18.60	1.08	19.67	1.79	0.30	0.15
iC7-60SL3AB5-1700	3 x AR12L		1700	19.05	0.94	19.69	1.37	0.29
iC7-60SL3AB5-1800		1800	20.47	1.04	21.18	1.51	0.29	0.22
iC7-60SL3AB5-2000		2000	23.67	1.30	24.57	1.90	0.34	0.22
iC7-60SL3AB5-2250		2250	27.90	1.60	29.05	2.37	0.43	0.22
iC7-60SL3AB5-2500	4 x AR12L	2500	28.88	1.52	30.31	2.47	0.38	0.30
iC7-60SL3AB5-2650		2650	31.30	1.68	32.94	2.78	0.46	0.30
iC7-60SL3AB5-2940		2940	36.16	2.03	38.22	3.40	0.55	0.30

1) System module and the LC Filter and AC fuses in the integration unit

2) System module and the LC Filter and AC fuses in the integration unit and the L Filter

3) DC fuses

10.7.10 Power Losses of GC Modules, Voltage Class G7, with +AEZ1 and +AEZ3

- The specifications for the values in the table
 - AC voltage 690 V AC
 - DC voltage 1500 V DC
 - Option +AEZ1 or +AEZ3

Table 134: Power Losses of GC Modules, Voltage Class G7 (380–690 V AC, 500–1500 V DC), with +AEZ1 and +AEZ3

Model code	Frame	Rated AC current I_N [A]	Grid Converter and +AEZ1 ⁽¹⁾		Grid Converter with +AEZ3 ⁽²⁾		+AKFX ⁽³⁾		Standby loss [kW]
			Power loss to liquid [kW]	Power loss to air [kW]	Power loss to liquid [kW]	Power loss to air [kW]	Power loss to air at 1500 V DC [kW]	Power loss to air at 1025 V DC [kW]	
iC7-60SLGCG7-760A	AR12L	776	8.4	0.5	8.6	0.9	0.01	0.10	0.14
iC7-60SLGCG7-970A		1000	13.3	0.7	13.7	1.3	0.07	0.15	0.14
iC7-60SLGCG7-1500	2 x AR12L	1532	16.4	1.0	17.1	2.1	0.02	0.20	0.27
iC7-60SLGCG7-1700		1736	20.5	1.0	21.5	2.4	0.08	0.24	0.27
iC7-60SLGCG7-1900		1950	25.4	1.3	26.6	3.1	0.11	0.31	0.27
iC7-60SLGCG7-2450	3 x AR12L	2501	28.6	1.8	29.6	3.2	0.11	0.32	0.41
iC7-60SLGCG7-2800		2900	37.5	1.9	38.8	3.8	0.17	0.44	0.41
iC7-60SLGCG7-3270	4 x AR12L	3338	38.3	2.4	40.0	5.0	0.14	0.42	0.55
iC7-60SLGCG7-3720		3850	49.6	2.5	51.9	6.0	0.23	0.59	0.55
iC7-60SLGCG7-4160	5 x AR12L	4247	49.4	3.1	51.2	5.8	0.21	0.56	0.69
iC7-60SLGCG7-4650	5 x AR12L	4800	61.7	3.1	64.0	6.6	0.28	0.74	0.69
iC7-60SLGCG7-5550	6 x AR12L	5750	73.7	3.7	77.2	8.9	0.34	0.84	0.82
iC7-60SLGCG7-6450	7 x AR12L	6650	84.7	4.3	88.0	9.3	0.34	0.99	0.96
iC7-60SLGCG7-7370	8 x AR12L	7600	96.8	4.9	101.3	11.6	0.39	1.13	1.10

1) Grid converter and the LC Filter and AC fuses

2) Grid converter and the LCL Filter (LC filter and L filter) and AC fuses

3) DC fuses

10.7.11 Power Losses of GC Modules, Voltage Class G7, with +AEZ1

- The specifications for the values in the table
 - AC voltage 690 V AC
 - DC voltage 1500 V DC
 - Option +AEZ1

Table 135: Power Losses of GC Modules, Voltage Class G7 (380–690 V AC, 500–1500 V DC), with +AEZ1

Model code	Frame	Rated AC current I_N [A]	Grid converter and +AEZ1 ⁽¹⁾		+AKFX ⁽²⁾		Standby loss [kW]
			Power loss to liquid [kW]	Power loss to air [kW]	Power loss to air at 1500 V DC [kW]	Power loss to air at 1025 V DC [kW]	
iC7-60SLGCG7-760A	AR12L	776	8.4	0.5	0.01	0.10	0.14
iC7-60SLGCG7-970A		1000	13.3	0.7	0.07	0.15	0.14
iC7-60SLGCG7-1500	2 x AR12L	1532	16.4	1.0	0.02	0.20	0.27
iC7-60SLGCG7-1700		1736	20.5	1.0	0.08	0.24	0.27
iC7-60SLGCG7-1900		1950	25.4	1.3	0.11	0.31	0.27

Table 135: Power Losses of GC Modules, Voltage Class G7 (380–690 V AC, 500–1500 V DC), with +AEZ1 - (continued)

Model code	Frame	Rated AC current I_N [A]	Grid converter and +AEZ1 ⁽¹⁾		+AKFX ⁽²⁾		Standby loss [kW]
			Power loss to liquid [kW]	Power loss to air [kW]	Power loss to air at 1500 V DC [kW]	Power loss to air at 1025 V DC [kW]	
iC7-60SLGCG7-2450	3 x AR12L	2501	28.6	1.8	0.11	0.32	0.41
iC7-60SLGCG7-2800		2900	37.5	1.9	0.17	0.44	0.41
iC7-60SLGCG7-3270	4 x AR12L	3338	38.3	2.4	0.14	0.42	0.55
iC7-60SLGCG7-3720		3850	49.6	2.5	0.23	0.59	0.55
iC7-60SLGCG7-4160	5 x AR12L	4247	49.4	3.1	0.21	0.56	0.69
iC7-60SLGCG7-4650		4800	61.7	3.1	0.28	0.74	0.69
iC7-60SLGCG7-5550	6 x AR12L	5750	73.7	3.7	0.34	0.84	0.82
iC7-60SLGCG7-6450	7 x AR12L	6650	84.7	4.3	0.34	0.99	0.96
iC7-60SLGCG7-7370	8 x AR12L	7600	96.8	4.9	0.39	1.13	1.10

1) Grid converter and the LC Filter and AC fuses

2) DC fuses

10.7.12 Power Losses of INU Modules with +AEU1, Voltage Class 07, Motor Cable Maximum Length 150 m (492 ft)

- The specifications for the values in the table
 - Inverter module
 - 525–690 V AC (640–1100 V DC)
 - Option +AEU1
 - Switching frequency 2 kHz or 3 kHz
 - Modulator type 6
 - Motor cable length a maximum of 150 m (492 ft)

Table 136: Power Losses for INU Modules with Option +AEU1, Motor Cable Maximum Length 150 m (492 ft)

Model code	Frame	Rated current $I_{L(1/5)}$ [A]	System module and +AEU1, 2 kHz switching frequency ⁽¹⁾		System module and +AEU1, 3 kHz switching frequency ⁽¹⁾		+AKFX ⁽²⁾	Standby loss [kW]
			Power loss to liquid [kW]	Power loss to air [kW]	Power loss to liquid [kW]	Power loss to air [kW]		
iC7-60SLIN07-170A	IR10L	170	2.07	0.08	2.58	0.10	0.03	0.07
iC7-60SLIN07-208A		208	2.42	0.09	2.99	0.11	0.05	0.07
iC7-60SLIN07-261A		261	2.98	0.11	3.58	0.13	0.05	0.07
iC7-60SLIN07-325A		325	3.71	0.14	4.39	0.16	0.07	0.07
iC7-60SLIN07-365A		365	4.66	0.18	5.40	0.20	0.08	0.07
iC7-60SLIN07-416A		416	5.35	0.21	6.26	0.23	0.10	0.07

Table 136: Power Losses for INU Modules with Option +AEU1, Motor Cable Maximum Length 150 m (492 ft) - (continued)

Model code	Frame	Rated current $I_{L(1/5)}$ [A]	System module and +AEU1, 2 kHz switching frequency ⁽¹⁾		System module and +AEU1, 3 kHz switching frequency ⁽¹⁾		+AKFX ⁽²⁾	Standby loss [kW]
			Power loss to liquid [kW]	Power loss to air [kW]	Power loss to liquid [kW]	Power loss to air [kW]	Power loss to air [kW]	
iC7-60SLIN07-465A	IR12L	465	5.25	0.18	6.48	0.23	0.07	0.13
iC7-60SLIN07-525A		525	5.80	0.20	7.11	0.24	0.10	0.13
iC7-60SLIN07-590A		590	6.53	0.22	7.84	0.26	0.12	0.13
iC7-60SLIN07-650A		650	7.11	0.24	8.56	0.28	0.14	0.13
iC7-60SLIN07-730A		730	8.73	0.29	10.29	0.35	0.16	0.13
iC7-60SLIN07-820A		820	10.24	0.35	12.28	0.42	0.20	0.13
iC7-60SLIN07-945A	2 x IR12L	945	11.05	0.37	13.11	0.46	0.15	0.26
iC7-60SLIN07-1060		1060	11.64	0.40	14.34	0.49	0.20	0.26
iC7-60SLIN07-1230		1230	13.45	0.45	16.27	0.54	0.26	0.26
iC7-60SLIN07-1400		1400	15.37	0.51	18.39	0.60	0.26	0.26
iC7-60SLIN07-1500		1500	18.43	0.64	22.56	0.79	0.31	0.26
iC7-60SLIN07-1640		1640	20.21	0.69	24.56	0.84	0.41	0.26
iC7-60SLIN07-1795	3 x IR12L	1795	20.77	0.74	25.89	0.91	0.38	0.39
iC7-60SLIN07-2080		2080	24.32	0.83	29.42	1.00	0.43	0.39
iC7-60SLIN07-2300		2300	28.18	0.97	34.51	1.20	0.52	0.39
iC7-60SLIN07-2500		2460	30.86	1.05	37.45	1.28	0.65	0.39
iC7-60SLIN07-2830	4 x IR12L	2830	33.06	1.13	39.96	1.36	0.58	0.52
iC7-60SLIN07-3050		3050	37.52	1.29	45.79	1.59	0.70	0.52
iC7-60SLIN07-3260		3260	40.33	1.38	48.80	1.67	0.79	0.52
iC7-60SLIN07-3500	5 x IR12L	3500	40.96	1.40	49.46	1.68	0.72	0.66
iC7-60SLIN07-4035		4035	49.61	1.70	60.40	2.08	0.99	0.66
iC7-60SLIN07-4400	6 x IR12L	4400	52.44	1.76	62.02	2.09	0.94	0.79
iC7-60SLIN07-4850		4850	59.59	2.04	72.64	2.50	1.19	0.79
iC7-60SLIN07-5300	7 x IR12L	5300	64.60	2.24	79.58	2.76	1.22	0.92
iC7-60SLIN07-5600		5600	69.29	2.37	83.86	2.89	1.34	0.92
iC7-60SLIN07-6100	8 x IR12L	6100	75.02	2.58	91.56	3.18	1.39	1.05
iC7-60SLIN07-6400		6400	78.67	2.70	95.85	3.30	1.54	1.05

1) System module and the dU/dt Filter in the integration unit

2) DC fuses

10.7.13 Power Losses of INU Modules with +AEU1, Voltage Class 07, Motor Cable Maximum Length 50 m (164 ft)

- The specifications for the values in the table
 - Inverter module

- 525–690 V AC (640–1100 V DC)
- Option +AEU1
- Switching frequency 2 kHz or 3 kHz
- Modulator type 6
- Motor cable length a maximum of 50 m (164 ft)

Table 137: Power Loss for INU Modules with Option +AEU1, Motor Cable Maximum Length 50 m (164 ft)

Model code	Frame	Rated current $I_{L(1/5)}$ [A]	System module and +AEU1, 2 kHz switching frequency ⁽¹⁾		System module and +AEU1, 3 kHz switching frequency ⁽¹⁾		+AKFX ⁽²⁾	Standby loss [kW]
			Power loss to liquid [kW]	Power loss to air [kW]	Power loss to liquid [kW]	Power loss to air [kW]	Power loss to air [kW]	
iC7-60SLIN07-170A	IR10L	170	1.83	0.07	2.27	0.08	0.03	0.07
iC7-60SLIN07-208A		208	2.17	0.08	2.65	0.10	0.05	0.07
iC7-60SLIN07-261A		261	2.73	0.10	3.24	0.11	0.05	0.07
iC7-60SLIN07-325A		325	3.46	0.13	4.05	0.14	0.07	0.07
iC7-60SLIN07-365A		365	4.17	0.15	4.75	0.17	0.08	0.07
iC7-60SLIN07-416A		416	4.82	0.18	5.56	0.20	0.10	0.07
iC7-60SLIN07-465A	IR12L	465	4.64	0.15	5.69	0.19	0.07	0.13
iC7-60SLIN07-525A		525	5.19	0.17	6.31	0.20	0.10	0.13
iC7-60SLIN07-590A		590	5.92	0.19	7.05	0.22	0.12	0.13
iC7-60SLIN07-650A		650	6.50	0.20	7.77	0.24	0.14	0.13
iC7-60SLIN07-730A		730	7.75	0.24	9.00	0.28	0.16	0.13
iC7-60SLIN07-820A		820	8.99	0.28	10.46	0.33	0.20	0.13
iC7-60SLIN07-945A	2 x IR12L	945	9.84	0.31	11.53	0.38	0.15	0.26
iC7-60SLIN07-1060		1060	10.42	0.34	12.75	0.41	0.20	0.26
iC7-60SLIN07-1230		1230	12.23	0.39	14.69	0.46	0.26	0.26
iC7-60SLIN07-1400		1400	14.15	0.44	16.81	0.52	0.26	0.26
iC7-60SLIN07-1500		1500	15.93	0.51	18.92	0.60	0.31	0.26
iC7-60SLIN07-1640		1640	17.72	0.56	20.92	0.65	0.41	0.26
iC7-60SLIN07-1795	3 x IR12L	1795	17.83	0.58	22.01	0.70	0.38	0.39
iC7-60SLIN07-2080		2080	21.39	0.68	25.55	0.80	0.43	0.39
iC7-60SLIN07-2300		2300	24.43	0.78	29.05	0.91	0.52	0.39
iC7-60SLIN07-2500		2460	27.12	0.86	31.99	0.99	0.65	0.39
iC7-60SLIN07-2830	4 x IR12L	2830	29.14	0.92	34.79	1.08	0.58	0.52
iC7-60SLIN07-3050		3050	32.53	1.03	38.52	1.21	0.70	0.52
iC7-60SLIN07-3260		3260	35.34	1.11	41.53	1.29	0.79	0.52
iC7-60SLIN07-3500	5 x IR12L	3500	36.06	1.14	43.00	1.34	0.72	0.66
iC7-60SLIN07-4035		4035	43.38	1.37	51.31	1.60	0.99	0.66

Table 137: Power Loss for INU Modules with Option +AEU1, Motor Cable Maximum Length 50 m (164 ft) - (continued)

Model code	Frame	Rated current $I_{L(1/5)}$ [A]	System module and +AEU1, 2 kHz switching frequency ⁽¹⁾		System module and +AEU1, 3 kHz switching frequency ⁽¹⁾		+AKFX ⁽²⁾	Standby loss [kW]
			Power loss to liquid [kW]	Power loss to air [kW]	Power loss to liquid [kW]	Power loss to air [kW]		
iC7-60SLIN07-4400	6 x IR12L	4400	46.57	1.45	54.27	1.69	0.94	0.79
iC7-60SLIN07-4850		4850	52.10	1.65	61.73	1.92	1.19	0.79
iC7-60SLIN07-5300	7 x IR12L	5300	55.86	1.78	66.85	2.09	1.22	0.92
iC7-60SLIN07-5600		5600	60.56	1.91	71.13	2.22	1.34	0.92
iC7-60SLIN07-6100	8 x IR12L	6100	65.04	2.06	77.02	2.41	1.39	1.05
iC7-60SLIN07-6400		6400	68.70	2.17	81.30	2.53	1.54	1.05

1) System module and the dU/dt Filter in the integration unit

2) DC fuses

10.7.14 Power Losses of INU modules 400 V AC (594 V DC), Voltage class A5, Modulator Type 1

- The specifications for the values in the table
 - Inverter module
 - 400 V AC (594 V DC)
 - DC voltage 1025 V DC
 - Switching frequency 2, 3, 4, or 5 kHz, see [Table 138](#)
 - Switching frequency 6, 8, or 10 kHz, see [Table 139](#)
 - Modulator type 1

Table 138: Power Loss for INU Modules, 2, 3, 4, or 5 kHz Switching Frequency, Modulator Type 1

Model code	Frame	Rated current $I_{L(1/5)}$ [A]	System module, 2 kHz switching frequency		System module, 3 kHz switching frequency		System module, 4 kHz switching frequency		System module, 5 kHz switching frequency		+AKFX ⁽¹⁾	Standby loss [kW]
			Power loss to liquid [kW]	Power loss to air [kW]	Power loss to liquid [kW]	Power loss to air [kW]	Power loss to liquid [kW]	Power loss to air [kW]	Power loss to liquid [kW]	Power loss to air [kW]		
iC7-60SLINA5-206A	IR10L	206	0.81	0.01	0.92	0.01	1.03	0.01	1.15	0.01	0.05	0.06
iC7-60SLINA5-245A		245	0.99	0.01	1.12	0.01	1.26	0.01	1.40	0.01	0.07	0.06
iC7-60SLINA5-302A		302	1.27	0.01	1.44	0.01	1.61	0.02	1.80	0.02	0.06	0.06
iC7-60SLINA5-385A		385	1.72	0.02	1.95	0.02	2.18	0.02	2.43	0.02	0.09	0.06
iC7-60SLINA5-480A		480	2.31	0.02	2.61	0.03	2.93	0.03	3.27	0.03	0.10	0.06
iC7-60SLINA5-520A		520	2.57	0.03	2.91	0.03	3.27	0.03	3.66	0.04	0.12	0.06

Table 138: Power Loss for INU Modules, 2, 3, 4, or 5 kHz Switching Frequency, Modulator Type 1 - (continued)

Model code	Frame	Rated current $I_{L(1/5)}$ [A]	System module, 2 kHz switching frequency		System module, 3 kHz switching frequency		System module, 4 kHz switching frequency		System module, 5 kHz switching frequency		+AKFX ⁽¹⁾ Power loss to air [kW]	Standby loss [kW]
			Power loss to liquid [kW]	Power loss to air [kW]	Power loss to liquid [kW]	Power loss to air [kW]	Power loss to liquid [kW]	Power loss to air [kW]	Power loss to liquid [kW]	Power loss to air [kW]		
iC7-60SLINA5-658A	IR12L	658	2.82	0.03	3.19	0.03	3.58	0.04	3.99	0.04	0.15	0.11
iC7-60SLINA5-730A		730	3.22	0.03	3.64	0.04	4.08	0.04	4.55	0.05	0.16	0.11
iC7-60SLINA5-820A		820	3.74	0.04	4.22	0.04	4.74	0.05	5.29	0.05	0.21	0.11
iC7-60SLINA5-880A		880	4.10	0.04	4.64	0.05	5.20	0.05	5.81	0.06	0.16	0.11
iC7-60SLINA5-1000		1000	4.88	0.05	5.51	0.06	6.19	0.06	6.92	0.07	0.22	0.11
iC7-60SLINA5-1270	2xIR12L	1270	5.40	0.05	6.11	0.06	6.86	0.07	7.63	0.08	0.28	0.22
iC7-60SLINA5-1460		1460	6.44	0.06	7.28	0.07	8.16	0.08	9.10	0.09	0.33	0.22
iC7-60SLINA5-1630		1630	7.41	0.07	8.38	0.08	9.40	0.09	10.49	0.10	0.40	0.22
iC7-60SLINA5-1760		1760	8.20	0.08	9.28	0.09	10.40	0.10	11.61	0.12	0.34	0.22
iC7-60SLINA5-1960		1960	9.48	0.09	10.72	0.11	12.04	0.12	13.46	0.13	0.43	0.22
iC7-60SLINA5-2150	3xIR12L	2150	9.43	0.09	10.66	0.11	11.96	0.12	13.30	0.13	0.45	0.33
iC7-60SLINA5-2340		2340	10.51	0.11	11.88	0.12	13.32	0.13	14.85	0.15	0.54	0.33
iC7-60SLINA5-2510		2510	11.51	0.12	13.01	0.13	14.60	0.15	16.27	0.16	0.44	0.33
iC7-60SLINA5-2880		2880	13.83	0.14	15.63	0.16	17.56	0.18	19.62	0.20	0.61	0.33
iC7-60SLINA5-3120	4xIR12L	3120	14.01	0.14	15.84	0.16	17.76	0.18	19.80	0.20	0.73	0.44
iC7-60SLINA5-3420		3420	15.79	0.16	17.85	0.18	20.03	0.20	22.35	0.22	0.62	0.44
iC7-60SLINA5-3820		3820	18.31	0.18	20.70	0.21	23.25	0.23	25.97	0.26	0.81	0.44
iC7-60SLINA5-4140	5xIR12L	4140	18.92	0.19	21.39	0.21	24.00	0.24	26.77	0.27	1.06	0.55
iC7-60SLINA5-4500		4500	21.13	0.21	23.88	0.24	26.81	0.27	29.93	0.30	0.87	0.55
iC7-60SLINA5-4750		4750	22.73	0.23	25.69	0.26	28.85	0.29	32.23	0.32	0.97	0.55
iC7-60SLINA5-5220	6xIR12L	5220	24.33	0.24	27.39	0.27	30.74	0.31	34.31	0.34	0.97	0.66
iC7-60SLINA5-5680		5680	27.14	0.27	30.68	0.31	34.45	0.34	38.45	0.38	1.17	0.66

1) DC fuses

Table 139: Power Loss for INU Modules, 6, 8, or 10 kHz Switching Frequency, Modulator Type 1

Model code	Frame	Rated current $I_{L(1/5)}$ [A]	System module, 6 kHz switching frequency		System module, 8 kHz switching frequency		System module, 10 kHz switching frequency		+AKFX ⁽¹⁾	Standby loss [kW]
			Power loss to liquid [kW]	Power loss to air [kW]	Power loss to liquid [kW]	Power loss to air [kW]	Power loss to liquid [kW]	Power loss to air [kW]		
iC7-60SLINA5-206A	IR10L	206	1.26	0.01	1.52	0.02	1.79	0.02	0.05	0.06
iC7-60SLINA5-245A		245	1.55	0.02	1.86	0.02	2.20	0.02	0.07	0.06
iC7-60SLINA5-302A		302	1.99	0.02	2.40	0.02	2.85	0.03	0.06	0.06
iC7-60SLINA5-385A		385	2.70	0.03	3.28	0.03	3.93	0.04	0.09	0.06
iC7-60SLINA5-480A		480	3.64	0.04	4.46	0.04	5.42	0.05	0.10	0.06
iC7-60SLINA5-520A		520	4.08	0.04	5.02	0.05	6.14	0.06	0.12	0.06
iC7-60SLINA5-658A	IR12L	658	4.42	0.04	5.34	0.05	6.36	0.06	0.15	0.11
iC7-60SLINA5-730A		730	5.04	0.05	6.12	0.06	7.31	0.07	0.16	0.11
iC7-60SLINA5-820A		820	5.87	0.06	7.14	0.07	8.59	0.09	0.21	0.11
iC7-60SLINA5-880A		880	6.45	0.06	7.88	0.08	9.52	0.10	0.16	0.11
iC7-60SLINA5-1000		1000	7.71	0.08	9.47	0.09	11.55	0.12	0.22	0.11
iC7-60SLINA5-1270	2xIR12L	1270	8.45	0.08	10.20	0.10	12.15	0.12	0.28	0.22
iC7-60SLINA5-1460		1460	10.08	0.10	12.24	0.12	14.62	0.15	0.33	0.22
iC7-60SLINA5-1630		1630	11.64	0.12	14.16	0.14	17.04	0.17	0.40	0.22
iC7-60SLINA5-1760		1760	12.90	0.13	15.76	0.16	19.04	0.19	0.34	0.22
iC7-60SLINA5-1960		1960	14.98	0.15	18.39	0.18	22.38	0.22	0.43	0.22
iC7-60SLINA5-2150	3xIR12L	2150	14.76	0.15	17.88	0.18	21.39	0.21	0.45	0.33
iC7-60SLINA5-2340		2340	16.47	0.16	20.01	0.20	24.03	0.24	0.54	0.33
iC7-60SLINA5-2510		2510	18.07	0.18	22.02	0.22	26.53	0.27	0.44	0.33
iC7-60SLINA5-2880		2880	21.83	0.22	26.76	0.27	32.53	0.33	0.61	0.33
iC7-60SLINA5-3120	4xIR12L	3120	21.96	0.22	26.68	0.27	32.04	0.32	0.73	0.44
iC7-60SLINA5-3420		3420	24.81	0.25	30.26	0.30	36.50	0.37	0.62	0.44
iC7-60SLINA5-3820		3820	28.89	0.29	35.41	0.35	43.02	0.43	0.81	0.44
iC7-60SLINA5-4140	5xIR12L	4140	29.71	0.30	36.18	0.36	43.57	0.44	1.06	0.55
iC7-60SLINA5-4500		4500	33.26	0.33	40.65	0.41	49.20	0.49	0.87	0.55
iC7-60SLINA5-4750		4750	35.85	0.36	43.93	0.44	53.35	0.53	0.97	0.55
iC7-60SLINA5-5220	6xIR12L	5220	38.11	0.38	46.50	0.47	56.16	0.56	0.97	0.66
iC7-60SLINA5-5680		5680	42.81	0.43	52.44	0.52	63.68	0.64	1.17	0.66

1) DC fuses

10.7.15 Power Losses of INU modules 400 V AC (594 V DC), Voltage class A5, Modulator Type 2

- The specifications for the values in the table
 - Inverter module

- 400 V AC (594 V DC)
- DC voltage 1025 V DC
- Switching frequency 2, 3, 4, or 5 kHz, see [Table 140](#)
- Switching frequency 6, 8, or 10 kHz, see [Table 141](#)
- Modulator type 2

Table 140: Power Loss for INU Modules, 2, 3, 4, or 5 kHz Switching Frequency, Modulator Type 2

Model code	Frame	Rated current $I_{L(1/5)}$ [A]	System module, 2 kHz switching frequency		System module, 3 kHz switching frequency		System module, 4 kHz switching frequency		System module, 5 kHz switching frequency		+AKFX ⁽¹⁾ Power loss to air [kW]	Standby loss [kW]
			Power loss to liquid [kW]	Power loss to air [kW]	Power loss to liquid [kW]	Power loss to air [kW]	Power loss to liquid [kW]	Power loss to air [kW]	Power loss to liquid [kW]	Power loss to air [kW]		
iC7-60SLINA5-206A	IR10L	206	0.74	0.01	0.81	0.01	0.88	0.01	1.52	0.02	0.05	0.06
iC7-60SLINA5-245A		245	0.90	0.01	0.99	0.01	1.08	0.01	1.86	0.02	0.07	0.06
iC7-60SLINA5-302A		302	1.16	0.01	1.27	0.01	1.39	0.01	2.40	0.02	0.06	0.06
iC7-60SLINA5-385A		385	1.57	0.02	1.72	0.02	1.88	0.02	3.28	0.03	0.09	0.06
iC7-60SLINA5-480A		480	2.11	0.02	2.31	0.02	2.51	0.03	4.46	0.04	0.10	0.06
iC7-60SLINA5-520A		520	2.35	0.02	2.57	0.03	2.81	0.03	5.02	0.05	0.12	0.06
iC7-60SLINA5-658A	IR12L	658	2.57	0.03	2.82	0.03	3.08	0.03	5.34	0.05	0.15	0.11
iC7-60SLINA5-730A		730	2.94	0.03	3.22	0.03	3.51	0.04	6.12	0.06	0.16	0.11
iC7-60SLINA5-820A		820	3.41	0.03	3.74	0.04	4.07	0.04	7.14	0.07	0.21	0.11
iC7-60SLINA5-880A		880	3.75	0.04	4.10	0.04	4.47	0.04	7.88	0.08	0.16	0.11
iC7-60SLINA5-1000		1000	4.45	0.04	4.88	0.05	5.32	0.05	9.47	0.09	0.22	0.11
iC7-60SLINA5-1270	2xIR12L	1270	4.93	0.05	5.40	0.05	5.90	0.06	10.20	0.10	0.28	0.22
iC7-60SLINA5-1460		1460	5.88	0.06	6.44	0.06	7.02	0.07	12.24	0.12	0.33	0.22
iC7-60SLINA5-1630		1630	6.77	0.07	7.41	0.07	8.08	0.08	14.16	0.14	0.40	0.22
iC7-60SLINA5-1760		1760	7.50	0.08	8.20	0.08	8.94	0.09	15.76	0.16	0.34	0.22
iC7-60SLINA5-1960		1960	8.66	0.09	9.48	0.09	10.34	0.10	18.39	0.18	0.43	0.22
iC7-60SLINA5-2150	3xIR12L	2150	8.60	0.09	9.43	0.09	10.28	0.10	17.88	0.18	0.45	0.33
iC7-60SLINA5-2340		2340	9.59	0.10	10.51	0.11	11.46	0.11	20.01	0.20	0.54	0.33
iC7-60SLINA5-2510		2510	10.51	0.11	11.51	0.12	12.55	0.13	22.02	0.22	0.44	0.33
iC7-60SLINA5-2880		2880	12.63	0.13	13.83	0.14	15.01	0.15	26.76	0.27	0.61	0.33
iC7-60SLINA5-3120	4xIR12L	3120	12.79	0.13	14.01	0.14	15.28	0.15	26.68	0.27	0.73	0.44
iC7-60SLINA5-3420		3420	14.42	0.14	15.79	0.16	17.22	0.17	30.26	0.30	0.62	0.44
iC7-60SLINA5-3820		3820	16.73	0.17	18.31	0.18	19.97	0.20	35.41	0.35	0.81	0.44
iC7-60SLINA5-4140	5xIR12L	4140	17.28	0.17	18.92	0.19	20.63	0.21	36.18	0.36	1.06	0.55
iC7-60SLINA5-4500		4500	19.30	0.19	21.13	0.21	23.04	0.23	40.65	0.41	0.87	0.55
iC7-60SLINA5-4750		4750	20.76	0.21	22.73	0.23	24.78	0.25	43.93	0.44	0.97	0.55

Table 140: Power Loss for INU Modules, 2, 3, 4, or 5 kHz Switching Frequency, Modulator Type 2 - (continued)

Model code	Frame	Rated current $I_{L(1/5)}$ [A]	System module, 2 kHz switching frequency		System module, 3 kHz switching frequency		System module, 4 kHz switching frequency		System module, 5 kHz switching frequency		+AKFX ⁽¹⁾	Standby loss [kW]
			Power loss to liquid [kW]	Power loss to air [kW]	Power loss to liquid [kW]	Power loss to air [kW]	Power loss to liquid [kW]	Power loss to air [kW]	Power loss to liquid [kW]	Power loss to air [kW]		
iC7-60SLINA5-5220	6xIR12L	5220	22.13	0.22	24.23	0.24	26.43	0.26	46.50	0.47	0.97	0.66
iC7-60SLINA5-5680		5680	24.79	0.25	27.14	0.27	29.59	0.30	52.44	0.52	1.17	0.66

1) DC fuses

Table 141: Power Loss for INU Modules, 6, 8, or 10 kHz Switching Frequency, Modulator Type 2

Model code	Frame	Rated current $I_{L(1/5)}$ [A]	System module, 6 kHz switching frequency		System module, 8 kHz switching frequency		System module, 10 kHz switching frequency		+AKFX ⁽¹⁾	Standby loss [kW]
			Power loss to liquid [kW]	Power loss to air [kW]	Power loss to liquid [kW]	Power loss to air [kW]	Power loss to liquid [kW]	Power loss to air [kW]		
iC7-60SLINA5-206A	IR10L	206	1.79	0.02	1.15	0.01	1.26	0.01	0.05	0.06
iC7-60SLINA5-245A		245	2.20	0.02	1.40	0.01	1.55	0.02	0.07	0.06
iC7-60SLINA5-302A		302	2.85	0.03	1.80	0.02	1.99	0.02	0.06	0.06
iC7-60SLINA5-385A		385	3.93	0.04	2.43	0.02	2.70	0.03	0.09	0.06
iC7-60SLINA5-480A		480	5.42	0.05	3.27	0.03	3.64	0.04	0.10	0.06
iC7-60SLINA5-520A		520	6.14	0.06	3.66	0.04	4.08	0.04	0.12	0.06
iC7-60SLINA5-658A	IR12L	658	6.36	0.06	3.99	0.04	4.42	0.04	0.15	0.11
iC7-60SLINA5-730A		730	7.31	0.07	4.55	0.05	5.04	0.05	0.16	0.11
iC7-60SLINA5-820A		820	8.59	0.09	5.29	0.05	5.87	0.06	0.21	0.11
iC7-60SLINA5-880A		880	9.52	0.10	5.81	0.06	6.45	0.06	0.16	0.11
iC7-60SLINA5-1000		1000	11.55	0.12	6.92	0.07	7.71	0.08	0.22	0.11
iC7-60SLINA5-1270	2xIR12L	1270	12.15	0.12	7.63	0.08	8.45	0.08	0.28	0.22
iC7-60SLINA5-1460		1460	14.62	0.15	9.10	0.09	10.08	0.10	0.33	0.22
iC7-60SLINA5-1630		1630	17.04	0.17	10.49	0.10	11.64	0.12	0.40	0.22
iC7-60SLINA5-1760		1760	19.04	0.19	11.61	0.12	12.90	0.13	0.34	0.22
iC7-60SLINA5-1960		1960	22.38	0.22	13.46	0.13	14.98	0.15	0.43	0.22
iC7-60SLINA5-2150	3xIR12L	2150	21.39	0.21	13.30	0.13	14.76	0.15	0.45	0.33
iC7-60SLINA5-2340		2340	24.03	0.24	14.85	0.15	16.47	0.16	0.54	0.33
iC7-60SLINA5-2510		2510	26.53	0.27	16.27	0.16	18.07	0.18	0.44	0.33
iC7-60SLINA5-2880		2880	32.53	0.33	19.62	0.20	21.83	0.22	0.61	0.33

Table 141: Power Loss for INU Modules, 6, 8, or 10 kHz Switching Frequency, Modulator Type 2 - (continued)

Model code	Frame	Rated current $I_{L(1/5)}$ [A]	System module, 6 kHz switching frequency		System module, 8 kHz switching frequency		System module, 10 kHz switching frequency		+AKFX ⁽¹⁾	Standby loss [kW]
			Power loss to liquid [kW]	Power loss to air [kW]	Power loss to liquid [kW]	Power loss to air [kW]	Power loss to liquid [kW]	Power loss to air [kW]		
iC7-60SLINA5-3120	4xIR12L	3120	32.04	0.32	19.80	0.20	21.96	0.22	0.73	0.44
iC7-60SLINA5-3420		3420	36.50	0.37	22.35	0.22	24.81	0.25	0.62	0.44
iC7-60SLINA5-3820		3820	43.02	0.43	25.97	0.26	28.89	0.29	0.81	0.44
iC7-60SLINA5-4140	5xIR12L	4140	43.57	0.44	26.77	0.27	29.71	0.30	1.06	0.55
iC7-60SLINA5-4500		4500	49.20	0.49	29.93	0.30	33.26	0.33	0.87	0.55
iC7-60SLINA5-4750		4750	53.35	0.53	32.23	0.32	35.85	0.36	0.97	0.55
iC7-60SLINA5-5220	6xIR12L	5220	56.16	0.56	34.31	0.34	38.11	0.38	0.97	0.66
iC7-60SLINA5-5680		5680	63.68	0.64	38.45	0.38	42.81	0.43	1.17	0.66

1) DC fuses

10.7.16 Power Losses of INU modules 500 V AC (460–800 V DC), Voltage class A5, Modulator Type 1

- The specifications for the values in the table
 - Inverter module
 - 500 V AC (460–800 V DC)
 - Switching frequency 2, 3, 4, or 5 kHz, see [Table 142](#)
 - Switching frequency 6, 8, or 10 kHz, see [Table 143](#)
 - Modulator type 1

Table 142: Power Loss for INU Modules 2, 3, 4, or 5 kHz Switching Frequency, Modulator Type 1

Model code	Frame	Rated current $I_{L(1/5)}$ [A]	System module, 2 kHz switching frequency		System module, 3 kHz switching frequency		System module, 4 kHz switching frequency		System module, 5 kHz switching frequency		+AKFX ⁽¹⁾	Standby loss [kW]
			Power loss to liquid [kW]	Power loss to air [kW]	Power loss to liquid [kW]	Power loss to air [kW]	Power loss to liquid [kW]	Power loss to air [kW]	Power loss to liquid [kW]	Power loss to air [kW]		
iC7-60SLINA5-206A	IR10L	206	0.88	0.01	1.03	0.01	1.18	0.01	1.34	0.01	0.05	0.06
iC7-60SLINA5-245A		245	1.07	0.01	1.25	0.01	1.44	0.01	1.64	0.02	0.07	0.06
iC7-60SLINA5-302A		302	1.38	0.01	1.61	0.02	1.85	0.02	2.11	0.02	0.06	0.06
iC7-60SLINA5-385A		385	1.87	0.02	2.18	0.02	2.51	0.03	2.87	0.03	0.09	0.06
iC7-60SLINA5-480A		480	2.50	0.03	2.92	0.03	3.37	0.03	3.87	0.04	0.10	0.06
iC7-60SLINA5-520A		520	2.64	0.03	3.09	0.03	3.57	0.04	4.10	0.04	0.12	0.06

Table 142: Power Loss for INU Modules 2, 3, 4, or 5 kHz Switching Frequency, Modulator Type 1 - (continued)

Model code	Frame	Rated current $I_{L(1/5)}$ [A]	System module, 2 kHz switching frequency		System module, 3 kHz switching frequency		System module, 4 kHz switching frequency		System module, 5 kHz switching frequency		+AKFX ⁽¹⁾	Standby loss [kW]
			Power loss to liquid [kW]	Power loss to air [kW]	Power loss to liquid [kW]	Power loss to air [kW]	Power loss to liquid [kW]	Power loss to air [kW]	Power loss to liquid [kW]	Power loss to air [kW]		
iC7-60SLINA5-658A	IR12L	658	3.06	0.03	3.57	0.04	4.11	0.04	4.69	0.05	0.15	0.13
iC7-60SLINA5-730A		730	3.49	0.03	4.07	0.04	4.69	0.05	5.35	0.05	0.16	0.13
iC7-60SLINA5-820A		820	4.05	0.04	4.72	0.05	5.45	0.05	6.23	0.06	0.21	0.13
iC7-60SLINA5-880A		880	4.44	0.04	5.18	0.05	5.99	0.06	6.86	0.07	0.16	0.13
iC7-60SLINA5-1000		1000	4.92	0.05	5.75	0.06	6.65	0.07	7.63	0.08	0.22	0.13
iC7-60SLINA5-1270	2xIR12L	1270	5.86	0.06	6.83	0.07	7.87	0.08	8.98	0.09	0.28	0.26
iC7-60SLINA5-1460		1460	6.98	0.07	8.14	0.08	9.38	0.09	10.70	0.11	0.33	0.26
iC7-60SLINA5-1630		1630	8.03	0.08	9.37	0.09	10.81	0.11	12.38	0.12	0.40	0.26
iC7-60SLINA5-1760		1760	8.88	0.09	10.36	0.10	11.98	0.12	13.72	0.14	0.34	0.26
iC7-60SLINA5-1960		1960	9.50	0.10	11.09	0.11	12.81	0.13	14.72	0.15	0.43	0.26
iC7-60SLINA5-2150	3xIR12L	2150	10.22	0.10	11.92	0.12	13.73	0.14	15.65	0.16	0.45	0.38
iC7-60SLINA5-2340		2340	11.39	0.11	13.28	0.13	15.31	0.15	17.49	0.17	0.54	0.38
iC7-60SLINA5-2510		2510	12.47	0.12	14.55	0.15	16.79	0.17	19.19	0.19	0.44	0.38
iC7-60SLINA5-2880		2880	14.15	0.14	16.51	0.17	19.08	0.19	21.88	0.22	0.61	0.38
iC7-60SLINA5-3120	4xIR12L	3120	15.19	0.15	17.71	0.18	20.41	0.20	23.33	0.23	0.73	0.51
iC7-60SLINA5-3420		3420	17.11	0.17	19.96	0.20	23.04	0.23	26.42	0.26	0.62	0.51
iC7-60SLINA5-3820		3820	18.66	0.19	21.77	0.22	25.16	0.25	28.82	0.29	0.81	0.51
iC7-60SLINA5-4140	5xIR12L	4140	19.24	0.19	22.44	0.22	25.87	0.26	29.55	0.30	1.06	0.64
iC7-60SLINA5-4500		4500	21.16	0.21	24.68	0.25	28.48	0.28	32.60	0.33	0.87	0.64
iC7-60SLINA5-4750		4750	22.89	0.23	26.71	0.27	30.56	0.31	35.37	0.35	0.97	0.64
iC7-60SLINA5-5220	6xIR12L	5220	24.17	0.24	28.19	0.28	32.51	0.33	37.15	0.37	0.97	0.77
iC7-60SLINA5-5680		5680	27.13	0.27	31.66	0.32	36.56	0.37	41.92	0.42	1.17	0.77

1) DC fuses

Table 143: Power Loss for INU Modules, 6, 8, or 10 kHz Switching Frequency, Modulator Type 1

Model code	Frame	Rated current $I_{L(1/5)}$ [A]	System module, 6 kHz switching frequency		System module, 8 kHz switching frequency		System module, 10 kHz switching frequency		+AKFX ⁽¹⁾	Standby loss [kW]
			Power loss to liquid [kW]	Power loss to air [kW]	Power loss to liquid [kW]	Power loss to air [kW]	Power loss to liquid [kW]	Power loss to air [kW]		
iC7-60SLINA5-206A	IR10L	206	1.51	0.02	1.86	0.02	2.26	0.02	0.05	0.06
iC7-60SLINA5-245A		245	1.85	0.02	2.29	0.02	2.79	0.03	0.07	0.06
iC7-60SLINA5-302A		302	2.38	0.02	2.98	0.03	3.66	0.04	0.06	0.06
iC7-60SLINA5-385A		385	3.25	0.03	4.12	0.04	5.15	0.05	0.09	0.06
iC7-60SLINA5-480A		480	4.42	0.04	5.70	0.06	7.29	0.07	0.10	0.06
iC7-60SLINA5-520A		520	4.69	0.05	6.08	0.06	7.82	0.08	0.12	0.06
iC7-60SLINA5-658A	IR12L	658	5.30	0.05	6.66	0.07	8.23	0.08	0.15	0.13
iC7-60SLINA5-730A		730	6.06	0.06	7.66	0.08	9.53	0.10	0.16	0.13
iC7-60SLINA5-820A		820	7.08	0.07	9.01	0.09	11.33	0.11	0.21	0.13
iC7-60SLINA5-880A		880	7.81	0.08	9.99	0.10	12.65	0.13	0.16	0.13
iC7-60SLINA5-1000		1000	8.71	0.09	11.22	0.11	14.33	0.14	0.22	0.13
iC7-60SLINA5-1270	2xIR12L	1270	10.13	0.10	12.71	0.13	15.67	0.16	0.28	0.26
iC7-60SLINA5-1460		1460	12.12	0.12	15.32	0.15	19.06	0.19	0.33	0.26
iC7-60SLINA5-1630		1630	14.05	0.14	17.87	0.18	22.45	0.22	0.40	0.26
iC7-60SLINA5-1760		1760	15.62	0.16	19.98	0.20	25.30	0.25	0.34	0.26
iC7-60SLINA5-1960		1960	16.76	0.17	21.53	0.22	27.42	0.27	0.43	0.26
iC7-60SLINA5-2150	3xIR12L	2150	17.75	0.18	22.40	0.22	27.85	0.28	0.45	0.38
iC7-60SLINA5-2340		2340	19.85	0.20	25.18	0.25	31.52	0.32	0.54	0.38
iC7-60SLINA5-2510		2510	21.84	0.22	27.83	0.28	35.06	0.35	0.44	0.38
iC7-60SLINA5-2880		2880	24.95	0.25	32.04	0.32	40.77	0.41	0.61	0.38
iC7-60SLINA5-3120	4xIR12L	3120	26.47	0.26	33.57	0.34	42.03	0.42	0.73	0.51
iC7-60SLINA5-3420		3420	30.00	0.30	38.30	0.38	48.35	0.48	0.62	0.51
iC7-60SLINA5-3820		3820	32.87	0.33	42.19	0.42	53.64	0.54	0.81	0.51
iC7-60SLINA5-4140	5xIR12L	4140	33.57	0.34	42.61	0.43	53.38	0.53	1.06	0.64
iC7-60SLINA5-4500		4500	37.10	0.37	47.31	0.47	59.67	0.60	0.87	0.64
iC7-60SLINA5-4750		4750	40.30	0.40	51.65	0.52	65.57	0.66	0.97	0.64
iC7-60SLINA5-5220	6xIR12L	5220	42.25	0.42	53.76	0.54	67.56	0.68	0.97	0.77
iC7-60SLINA5-5680		5680	47.72	0.48	61.12	0.61	77.51	0.78	1.17	0.77

1) DC fuses

10.7.17 Power Losses of INU modules 500 V AC (460–800 V DC), Voltage class A5, Modulator Type 2

- The specifications for the values in the table
 - Inverter module

- 500 V AC (460–800 V DC)
- Switching frequency 2, 3, 4, or 5 kHz, see [Table 144](#)
- Switching frequency 6, 8, or 10 kHz, see [Table 145](#)
- Modulator type 2

Table 144: Power Loss for INU Modules 2, 3, 4, or 5 kHz Switching Frequency, Modulator Type 2

Model code	Frame	Rated current $I_{L(1/5)}$ [A]	System module, 2 kHz switching frequency		System module, 3 kHz switching frequency		System module, 4 kHz switching frequency		System module, 5 kHz switching frequency		+AKFX ⁽¹⁾ Power loss to air [kW]	Standby loss [kW]
			Power loss to liquid [kW]	Power loss to air [kW]	Power loss to liquid [kW]	Power loss to air [kW]	Power loss to liquid [kW]	Power loss to air [kW]	Power loss to liquid [kW]	Power loss to air [kW]		
iC7-60SLINA5-206A	IR10L	206	0.78	0.01	0.88	0.01	0.98	0.01	1.86	0.02	0.05	0.06
iC7-60SLINA5-245A		245	0.95	0.01	1.07	0.01	1.20	0.01	2.29	0.02	0.07	0.06
iC7-60SLINA5-302A		302	1.23	0.01	1.38	0.01	1.54	0.02	2.98	0.03	0.06	0.06
iC7-60SLINA5-385A		385	1.66	0.02	1.87	0.02	2.08	0.02	4.12	0.04	0.09	0.06
iC7-60SLINA5-480A		480	2.23	0.02	2.50	0.03	2.79	0.03	5.70	0.06	0.10	0.06
iC7-60SLINA5-520A		520	2.35	0.02	2.64	0.03	2.95	0.03	6.08	0.06	0.12	0.06
iC7-60SLINA5-658A	IR12L	658	2.72	0.03	3.06	0.03	3.42	0.03	6.66	0.07	0.15	0.13
iC7-60SLINA5-730A		730	3.10	0.03	3.49	0.03	3.89	0.04	7.66	0.08	0.16	0.13
iC7-60SLINA5-820A		820	3.61	0.04	4.05	0.04	4.52	0.05	9.01	0.09	0.21	0.13
iC7-60SLINA5-880A		880	3.96	0.04	4.44	0.04	4.96	0.05	9.99	0.10	0.16	0.13
iC7-60SLINA5-1000		1000	4.39	0.04	4.92	0.05	5.49	0.05	11.22	0.11	0.22	0.13
iC7-60SLINA5-1270	2xIR12L	1270	5.21	0.05	5.86	0.06	6.54	0.07	12.71	0.13	0.28	0.26
iC7-60SLINA5-1460		1460	6.20	0.06	6.98	0.07	7.78	0.08	15.32	0.15	0.33	0.26
iC7-60SLINA5-1630		1630	7.16	0.07	8.03	0.08	8.96	0.09	17.87	0.18	0.40	0.26
iC7-60SLINA5-1760		1760	7.92	0.08	8.88	0.09	9.92	0.10	19.98	0.20	0.34	0.26
iC7-60SLINA5-1960		1960	8.46	0.08	9.50	0.10	10.60	0.11	21.53	0.22	0.43	0.26
iC7-60SLINA5-2150	3xIR12L	2150	9.10	0.09	10.22	0.10	11.40	0.11	22.40	0.22	0.45	0.38
iC7-60SLINA5-2340		2340	10.40	0.10	11.39	0.11	12.70	0.13	25.18	0.25	0.54	0.38
iC7-60SLINA5-2510		2510	11.11	0.11	12.47	0.12	13.91	0.14	27.83	0.28	0.44	0.38
iC7-60SLINA5-2880		2880	12.60	0.13	14.15	0.14	15.78	0.16	32.04	0.32	0.61	0.38
iC7-60SLINA5-3120	4xIR12L	3120	13.87	0.14	15.19	0.15	16.93	0.17	33.57	0.34	0.73	0.51
iC7-60SLINA5-3420		3420	15.24	0.15	17.11	0.17	19.08	0.19	38.30	0.38	0.62	0.51
iC7-60SLINA5-3820		3820	16.62	0.17	18.66	0.19	20.81	0.21	42.19	0.42	0.81	0.51
iC7-60SLINA5-4140	5xIR12L	4140	17.13	0.17	19.24	0.19	21.46	0.21	42.61	0.43	1.06	0.64
iC7-60SLINA5-4500		4500	18.84	0.19	21.16	0.21	23.59	0.24	47.31	0.47	0.87	0.64
iC7-60SLINA5-4750		4750	20.39	0.20	22.89	0.23	25.54	0.26	51.65	0.52	0.97	0.64

Table 144: Power Loss for INU Modules 2, 3, 4, or 5 kHz Switching Frequency, Modulator Type 2 - (continued)

Model code	Frame	Rated current $I_{L(1/5)}$ [A]	System module, 2 kHz switching frequency		System module, 3 kHz switching frequency		System module, 4 kHz switching frequency		System module, 5 kHz switching frequency		+AKFX ⁽¹⁾	Standby loss [kW]
			Power loss to liquid [kW]	Power loss to air [kW]	Power loss to liquid [kW]	Power loss to air [kW]	Power loss to liquid [kW]	Power loss to air [kW]	Power loss to liquid [kW]	Power loss to air [kW]		
iC7-60SLINA5-5220	6xIR12L	5220	21.52	0.22	24.17	0.24	26.95	0.27	53.76	0.54	0.97	0.77
iC7-60SLINA5-5680		5680	24.17	0.25	27.13	0.27	30.26	0.31	61.12	0.61	1.17	0.77

1) DC fuses

Table 145: Power Loss for INU Modules 6, 8, or 10 kHz Switching Frequency, Modulator Type 2

Model code	Frame	Rated current $I_{L(1/5)}$ [A]	System module, 6 kHz switching frequency		System module, 8 kHz switching frequency		System module, 10 kHz switching frequency		+AKFX ⁽¹⁾	Standby loss [kW]
			Power loss to liquid [kW]	Power loss to air [kW]	Power loss to liquid [kW]	Power loss to air [kW]	Power loss to liquid [kW]	Power loss to air [kW]		
iC7-60SLINA5-206A	IR10L	206	2.26	0.02	1.34	0.01	1.51	0.02	0.05	0.06
iC7-60SLINA5-245A		245	2.79	0.03	1.64	0.02	1.85	0.02	0.07	0.06
iC7-60SLINA5-302A		302	3.66	0.04	2.11	0.02	2.38	0.02	0.06	0.06
iC7-60SLINA5-385A		385	5.15	0.05	2.87	0.03	3.25	0.03	0.09	0.06
iC7-60SLINA5-480A		480	7.29	0.07	3.87	0.04	4.42	0.04	0.10	0.06
iC7-60SLINA5-520A		520	7.82	0.08	4.10	0.04	4.69	0.05	0.12	0.06
iC7-60SLINA5-658A	IR12L	658	8.23	0.08	4.69	0.05	5.30	0.05	0.15	0.13
iC7-60SLINA5-730A		730	9.53	0.10	5.35	0.05	6.06	0.06	0.16	0.13
iC7-60SLINA5-820A		820	11.33	0.11	6.23	0.06	7.08	0.07	0.21	0.13
iC7-60SLINA5-880A		880	12.65	0.13	6.86	0.07	7.81	0.08	0.16	0.13
iC7-60SLINA5-1000		1000	14.33	0.14	7.63	0.08	8.71	0.09	0.22	0.13
iC7-60SLINA5-1270	2xIR12L	1270	15.67	0.16	8.98	0.09	10.13	0.10	0.28	0.26
iC7-60SLINA5-1460		1460	19.06	0.19	10.70	0.11	12.12	0.12	0.33	0.26
iC7-60SLINA5-1630		1630	22.45	0.22	12.38	0.12	14.05	0.14	0.40	0.26
iC7-60SLINA5-1760		1760	25.30	0.25	13.72	0.14	15.62	0.16	0.34	0.26
iC7-60SLINA5-1960		1960	27.42	0.27	14.72	0.15	16.76	0.17	0.43	0.26
iC7-60SLINA5-2150	3xIR12L	2150	27.85	0.28	15.65	0.16	17.75	0.18	0.45	0.38
iC7-60SLINA5-2340		2340	31.52	0.32	17.49	0.17	19.85	0.20	0.54	0.38
iC7-60SLINA5-2510		2510	35.06	0.35	19.19	0.19	21.84	0.22	0.44	0.38
iC7-60SLINA5-2880		2880	40.77	0.41	21.88	0.22	24.95	0.25	0.61	0.38

Table 145: Power Loss for INU Modules, 6, 8, or 10 kHz Switching Frequency, Modulator Type 2 - (continued)

Model code	Frame	Rated current $I_{L(1/5)}$ [A]	System module, 6 kHz switching frequency		System module, 8 kHz switching frequency		System module, 10 kHz switching frequency		+AKFX ⁽¹⁾	Standby loss [kW]
			Power loss to liquid [kW]	Power loss to air [kW]	Power loss to liquid [kW]	Power loss to air [kW]	Power loss to liquid [kW]	Power loss to air [kW]		
iC7-60SLINA5-3120	4xIR12L	3120	42.03	0.42	23.33	0.23	26.47	0.26	0.73	0.51
iC7-60SLINA5-3420		3420	48.35	0.48	26.42	0.26	30.00	0.30	0.62	0.51
iC7-60SLINA5-3820		3820	53.64	0.54	28.82	0.29	32.87	0.33	0.81	0.51
iC7-60SLINA5-4140	5xIR12L	4140	53.38	0.53	29.55	0.30	33.57	0.34	1.06	0.64
iC7-60SLINA5-4500		4500	59.67	0.60	32.60	0.33	37.10	0.37	0.87	0.64
iC7-60SLINA5-4750		4750	65.57	0.66	35.37	0.35	40.30	0.40	0.97	0.64
iC7-60SLINA5-5220	6xIR12L	5220	67.56	0.68	37.15	0.37	42.25	0.42	0.97	0.77
iC7-60SLINA5-5680		5680	77.51	0.78	41.92	0.42	47.72	0.48	1.17	0.77

1) DC fuses

10.7.18 Power Losses of INU Modules without Options, Voltage Class 07, Modulator Type 1 – SVPWM

- The specifications for the values in the table
 - Inverter module
 - 525–690 V AC (640–1100 V DC)
 - DC voltage 1025 V DC
 - Switching frequency 2, 3, 4, or 6 kHz
 - Modulator type 1

Table 146: Power Losses for INU Modules without Options, Modulator Type 1

Model code	Frame	Rated current $I_{L(1/5)}$ [A]	System module, 2 kHz switching frequency		System module, 3 kHz switching frequency		System module, 4 kHz switching frequency		System module, 6 kHz switching frequency		+AKFX ⁽¹⁾ Power loss to air [kW]
			Power loss to liquid [kW]	Power loss to air [kW]	Power loss to liquid [kW]	Power loss to air [kW]	Power loss to liquid [kW]	Power loss to air [kW]	Power loss to liquid [kW]	Power loss to air [kW]	
iC7-60SLIN07-170A	IM10L	170	1.20	0.01	1.51	0.02	1.83	0.02	2.46	0.02	0.03
iC7-60SLIN07-208A		208	1.49	0.02	1.87	0.02	2.27	0.02	3.17	0.03	0.05
iC7-60SLIN07-261A		261	1.95	0.02	2.46	0.02	2.99	0.03	–	–	0.05
iC7-60SLIN07-325A		325	2.57	0.03	3.23	0.03	–	–	–	–	0.07
iC7-60SLIN07-365A		365	3.00	0.03	–	–	–	–	–	–	0.08
iC7-60SLIN07-416A		416	3.60	0.04	–	–	–	–	–	–	0.10

Table 146: Power Losses for INU Modules without Options, Modulator Type 1 - (continued)

Model code	Frame	Rated current $I_{L(1/5)}$ [A]	System module, 2 kHz switching frequency		System module, 3 kHz switching frequency		System module, 4 kHz switching frequency		System module, 6 kHz switching frequency		+AKFX ⁽¹⁾ Power loss to air [kW]
			Power loss to liquid [kW]	Power loss to air [kW]	Power loss to liquid [kW]	Power loss to air [kW]	Power loss to liquid [kW]	Power loss to air [kW]	Power loss to liquid [kW]	Power loss to air [kW]	
iC7-60SLIN07-465A	IM12L	465	3.40	0.03	4.25	0.04	5.15	0.05	–	–	0.07
iC7-60SLIN07-525A		525	3.93	0.04	4.91	0.05	5.97	0.06	–	–	0.10
iC7-60SLIN07-590A		590	4.54	0.05	5.80	0.06	6.94	0.07	–	–	0.12
iC7-60SLIN07-650A		650	5.14	0.05	6.47	0.06	–	–	–	–	0.14
iC7-60SLIN07-730A		730	6.00	0.06	–	–	–	–	–	–	0.16
iC7-60SLIN07-820A		820	7.05	0.07	–	–	–	–	–	–	0.20
iC7-60SLIN07-945A	2 x IM12L	945	6.93	0.07	9.30	0.09	11.40	0.11	–	–	0.15
iC7-60SLIN07-1060		1060	7.95	0.08	9.83	0.10	11.95	0.12	–	–	0.20
iC7-60SLIN07-1230		1230	9.57	0.10	12.02	0.12	–	–	–	–	0.26
iC7-60SLIN07-1400		1400	11.33	0.11	14.30	0.14	–	–	–	–	0.26
iC7-60SLIN07-1500		1500	12.44	0.13	–	–	–	–	–	–	0.31
iC7-60SLIN07-1640		1640	14.10	0.14	–	–	–	–	–	–	0.41
iC7-60SLIN07-1795	3 x IM12L	1795	13.86	0.14	16.80	0.17	21.00	0.21	–	–	0.38
iC7-60SLIN07-2080		2080	16.79	0.17	21.14	0.21	–	–	–	–	0.43
iC7-60SLIN07-2300		2300	19.24	0.19	–	–	–	–	–	–	0.52
iC7-60SLIN07-2500		2460	21.64	0.22	–	–	–	–	–	–	0.65
iC7-60SLIN07-2830	4 x IM12L	2830	23.00	0.23	28.94	0.29	–	–	–	–	0.58
iC7-60SLIN07-3050		3050	25.47	0.26	–	–	–	–	–	–	0.70
iC7-60SLIN07-3260		3260	27.95	0.28	–	–	–	–	–	–	0.79
iC7-60SLIN07-3500	5 x IM12L	3500	28.33	0.29	35.75	0.36	–	–	–	–	0.72
iC7-60SLIN07-4035		4035	34.45	0.35	–	–	–	–	–	–	0.99
iC7-60SLIN07-4400	6 x IM12L	4400	36.21	0.37	–	–	–	–	–	–	0.94
iC7-60SLIN07-4850		4850	41.45	0.42	–	–	–	–	–	–	1.19
iC7-60SLIN07-5300	7 x IM12L	5300	44.14	0.45	–	–	–	–	–	–	1.22
iC7-60SLIN07-5600		5600	47.64	0.48	–	–	–	–	–	–	1.34
iC7-60SLIN07-6100	8 x IM12L	6100	50.94	0.51	–	–	–	–	–	–	1.39
iC7-60SLIN07-6400		6400	54.45	0.55	–	–	–	–	–	–	1.54

1) DC fuses

10.7.19 Power Losses of INU Modules without Options, Voltage Class 07, Modulator Type 6 – Optimized

- The specifications for the values in the table
 - Inverter module

- 525–690 V AC (640–1100 V DC)
- DC voltage 1025 V DC
- Switching frequency 2, 3, 4, or 6 kHz
- Modulator type 6

Table 147: Power Losses for INU Modules without Options, Modulator Type 6

Model code	Frame	Rated current $I_{L(1/5)}$ [A]	System module, 2 kHz switching frequency		System module, 3 kHz switching frequency		System module, 4 kHz switching frequency		System module, 6 kHz switching frequency		+AKFX ⁽¹⁾ Power loss to air [kW]
			Power loss to liquid [kW]	Power loss to air [kW]	Power loss to liquid [kW]	Power loss to air [kW]	Power loss to liquid [kW]	Power loss to air [kW]	Power loss to liquid [kW]	Power loss to air [kW]	
iC7-60SLIN07-170A	IM10L	170	1.00	0.01	1.20	0.01	1.47	0.01	1.83	0.02	0.03
iC7-60SLIN07-208A		208	1.25	0.01	1.49	0.02	1.83	0.02	2.27	0.02	0.05
iC7-60SLIN07-261A		261	1.68	0.02	1.95	0.02	2.37	0.02	2.99	0.03	0.05
iC7-60SLIN07-325A		325	2.21	0.02	2.57	0.03	3.15	0.03	–	–	0.07
iC7-60SLIN07-365A		365	2.68	0.03	3.00	0.03	3.93	0.04	–	–	0.08
iC7-60SLIN07-416A		416	3.13	0.03	3.60	0.04	–	–	–	–	0.10
iC7-60SLIN07-465A	IM12L	465	2.91	0.03	3.40	0.03	4.27	0.04	5.15	0.05	0.07
iC7-60SLIN07-525A		525	3.36	0.03	3.93	0.04	4.93	0.05	5.97	0.06	0.10
iC7-60SLIN07-590A		590	3.97	0.04	4.54	0.05	5.82	0.06	6.94	0.07	0.12
iC7-60SLIN07-650A		650	4.43	0.04	5.14	0.05	6.50	0.06	–	–	0.14
iC7-60SLIN07-730A		730	5.37	0.05	6.00	0.06	7.87	0.08	–	–	0.16
iC7-60SLIN07-820A		820	6.24	0.06	7.05	0.07	–	–	–	–	0.20
iC7-60SLIN07-945A	2 x IM12L	945	6.35	0.06	6.93	0.07	9.31	0.09	11.40	0.11	0.15
iC7-60SLIN07-1060		1060	6.73	0.07	7.95	0.08	9.88	0.10	11.95	0.12	0.20
iC7-60SLIN07-1230		1230	8.23	0.08	9.57	0.10	12.07	0.12	–	–	0.26
iC7-60SLIN07-1400		1400	9.80	0.10	11.33	0.11	14.37	0.14	–	–	0.26
iC7-60SLIN07-1500		1500	10.79	0.11	12.44	0.13	15.84	0.16	–	–	0.31
iC7-60SLIN07-1640		1640	12.23	0.12	14.10	0.14	–	–	–	–	0.41
iC7-60SLIN07-1795	3 x IM12L	1795	11.53	0.12	13.86	0.14	16.92	0.17	21.00	0.21	0.38
iC7-60SLIN07-2080		2080	14.48	0.14	16.79	0.17	21.25	0.21	–	–	0.43
iC7-60SLIN07-2300		2300	16.63	0.17	19.24	0.19	–	–	–	–	0.52
iC7-60SLIN07-2500		2460	18.77	0.19	21.64	0.22	–	–	–	–	0.65
iC7-60SLIN07-2830	4 x IM12L	2830	19.82	0.20	23.00	0.23	29.09	0.29	–	–	0.58
iC7-60SLIN07-3050		3050	22.15	0.22	25.47	0.26	–	–	–	–	0.70
iC7-60SLIN07-3260		3260	24.43	0.24	27.95	0.28	–	–	–	–	0.79
iC7-60SLIN07-3500	5 x IM12L	3500	24.49	0.24	28.33	0.29	35.93	0.36	–	–	0.72
iC7-60SLIN07-4035		4035	29.85	0.30	34.45	0.35	–	–	–	–	0.99

Table 147: Power Losses for INU Modules without Options, Modulator Type 6 - (continued)

Model code	Frame	Rated current $I_{L(1/5)}$ [A]	System module, 2 kHz switching frequency		System module, 3 kHz switching frequency		System module, 4 kHz switching frequency		System module, 6 kHz switching frequency		+AKFX ⁽¹⁾ Power loss to air [kW]
			Power loss to liquid [kW]	Power loss to air [kW]	Power loss to liquid [kW]	Power loss to air [kW]	Power loss to liquid [kW]	Power loss to air [kW]	Power loss to liquid [kW]	Power loss to air [kW]	
iC7-60SLIN07-4400	6 x IM12L	4400	32.21	0.32	36.21	0.37	47.24	0.47	–	–	0.94
iC7-60SLIN07-4850		4850	35.83	0.36	41.45	0.42	–	–	–	–	1.19
iC7-60SLIN07-5300	7 x IM12L	5300	37.82	0.38	44.14	0.45	55.51	0.56	–	–	1.22
iC7-60SLIN07-5600		5600	41.75	0.42	47.64	0.48	–	–	–	–	1.34
iC7-60SLIN07-6100	8 x IM12L	6100	44.30	0.44	50.94	0.51	–	–	–	–	1.39
iC7-60SLIN07-6400		6400	47.19	0.47	54.45	0.55	–	–	–	–	1.54

1) DC fuses

10.7.20 Power Losses of INU Modules with +AEU1, Voltage Class B5, Motor Cable Maximum Length 150 m (492 ft)

- The specifications for the values in the table
 - Inverter module
 - 380–500 V AC (465–800 V DC)
 - DC voltage 594 V DC
 - Option +AEU1
 - Switching frequency 2 kHz or 3 kHz
 - Modulator type 6
 - Motor cable length a maximum of 150 m (492 ft)

Table 148: Power Losses for INU Modules with Option +AEU1, Motor Cable Maximum Length 150 m (492 ft)

Model code	Frame	Rated current $I_{L(1/5)}$ [A]	System module and +AEU1, 2 kHz switching frequency ⁽¹⁾		System module and +AEU1, 3 kHz switching frequency ⁽¹⁾		+AKFX ⁽²⁾ Power loss to air [kW]	Standby loss [kW]
			Power loss to liquid [kW]	Power loss to air [kW]	Power loss to liquid [kW]	Power loss to air [kW]		
iC7-60SLINB5-206A	IR10L	206	1.64	0.06	1.94	0.07	0.04	0.036
iC7-60SLINB5-245A		245	1.97	0.07	2.31	0.08	0.04	0.036
iC7-60SLINB5-302A		302	2.51	0.09	2.92	0.10	0.06	0.036
iC7-60SLINB5-385A		385	3.55	0.14	4.12	0.15	0.09	0.036
iC7-60SLINB5-416A		416	3.94	0.16	4.55	0.17	0.10	0.036

Table 148: Power Losses for INU Modules with Option +AEU1, Motor Cable Maximum Length 150 m (492 ft) - (continued)

Model code	Frame	Rated current $I_{L(1/5)}$ [A]	System module and +AEU1, 2 kHz switching frequency ⁽¹⁾		System module and +AEU1, 3 kHz switching frequency ⁽¹⁾		+AKFX ⁽²⁾	Standby loss [kW]
			Power loss to liquid [kW]	Power loss to air [kW]	Power loss to liquid [kW]	Power loss to air [kW]	Power loss to air [kW]	
iC7-60SLINB5-525A	IR12L	525	4.05	0.13	4.82	0.15	0.10	0.072
iC7-60SLINB5-590A		590	4.59	0.15	5.45	0.17	0.12	0.072
iC7-60SLINB5-650A		650	5.16	0.17	6.17	0.19	0.14	0.072
iC7-60SLINB5-730A		730	6.08	0.20	7.17	0.22	0.16	0.072
iC7-60SLINB5-820A		820	7.18	0.24	8.49	0.27	0.20	0.072
iC7-60SLINB5-1060	2 x IR12L	1060	8.16	0.26	9.73	0.30	0.20	0.144
iC7-60SLINB5-1230		1230	9.66	0.31	11.42	0.35	0.26	0.144
iC7-60SLINB5-1400		1400	11.27	0.36	13.27	0.40	0.26	0.144
iC7-60SLINB5-1500		1500	12.84	0.42	15.23	0.48	0.31	0.144
iC7-60SLINB5-1640		1640	14.36	0.47	16.98	0.53	0.41	0.144
iC7-60SLINB5-1795	3 x IR12L	1795	14.43	0.47	17.18	0.54	0.38	0.216
iC7-60SLINB5-2080		2080	17.14	0.56	20.25	0.63	0.43	0.216
iC7-60SLINB5-2300		2300	19.77	0.65	23.45	0.74	0.52	0.216
iC7-60SLINB5-2500		2460	21.97	0.73	25.98	0.82	0.65	0.216
iC7-60SLINB5-2830	4 x IR12L	2830	23.42	0.76	27.64	0.86	0.58	0.288
iC7-60SLINB5-3050		3050	26.15	0.86	31.07	0.98	0.70	0.288
iC7-60SLINB5-3260		3260	28.57	0.94	33.69	1.06	0.79	0.288

1) System module and the dU/dt Filter in the integration unit

2) DC fuses

10.7.21 Power Losses of INU Modules with +AEU1, Voltage Class B5, Motor Cable Maximum Length 50 m (164 ft)

- The specifications for the values in the table
 - Inverter module
 - 380–500 V AC (465–800 V DC)
 - DC voltage 594 V DC
 - Option +AEU1
 - Switching frequency 2 kHz or 3 kHz
 - Modulator type 6
 - Motor cable length a maximum of 50 m (164 ft)

Table 149: Power Losses for INU Modules with Option +AEU1, Motor Cable Maximum Length 50 m (164 ft)

Model code	Frame	Rated current $I_{L(1/5)}$ [A]	System module and +AEU1, 2 kHz switching frequency ⁽¹⁾		System module and +AEU1, 3 kHz switching frequency ⁽¹⁾		+AKFX ⁽²⁾	Standby loss [kW]
			Power loss to liquid [kW]	Power loss to air [kW]	Power loss to liquid [kW]	Power loss to air [kW]	Power loss to air [kW]	
iC7-60SLINB5-206A	IR10L	206	1.56	0.06	1.84	0.06	0.04	0.036
iC7-60SLINB5-245A		245	1.89	0.07	2.21	0.08	0.04	0.036
iC7-60SLINB5-302A		302	2.43	0.09	2.81	0.10	0.06	0.036
iC7-60SLINB5-385A		385	3.39	0.13	3.90	0.14	0.09	0.036
iC7-60SLINB5-416A		416	3.78	0.15	4.33	0.16	0.10	0.036
iC7-60SLINB5-525A	IR12L	525	3.86	0.12	4.56	0.13	0.10	0.072
iC7-60SLINB5-590A		590	4.41	0.14	5.19	0.15	0.12	0.072
iC7-60SLINB5-650A		650	4.98	0.16	5.91	0.17	0.14	0.072
iC7-60SLINB5-730A		730	5.80	0.18	6.79	0.20	0.16	0.072
iC7-60SLINB5-820A		820	6.83	0.22	7.96	0.24	0.20	0.072
iC7-60SLINB5-1060	2 x IR12L	1060	7.79	0.24	9.21	0.27	0.20	0.144
iC7-60SLINB5-1230		1230	9.30	0.29	10.90	0.32	0.26	0.144
iC7-60SLINB5-1400		1400	10.91	0.34	12.75	0.38	0.26	0.144
iC7-60SLINB5-1500		1500	12.13	0.39	14.17	0.43	0.31	0.144
iC7-60SLINB5-1640		1640	13.65	0.44	15.92	0.48	0.41	0.144
iC7-60SLINB5-1795	3 x IR12L	1795	13.60	0.43	16.02	0.48	0.38	0.216
iC7-60SLINB5-2080		2080	16.32	0.51	19.09	0.57	0.43	0.216
iC7-60SLINB5-2300		2300	18.71	0.60	21.86	0.66	0.52	0.216
iC7-60SLINB5-2500		2460	20.90	0.67	24.39	0.73	0.65	0.216
iC7-60SLINB5-2830	4 x IR12L	2830	22.31	0.70	26.10	0.78	0.58	0.288
iC7-60SLINB5-3050		3050	24.73	0.79	28.95	0.87	0.70	0.288
iC7-60SLINB5-3260		3260	27.15	0.87	31.57	0.95	0.79	0.288

1) System module and the dU/dt Filter in the integration unit

2) DC fuses

10.7.22 Power Losses of INU Modules without Options, Voltage Class B5, Modulator Type 1 – SVPWM

- The specifications for the values in the table
 - Inverter module
 - 380–500 V AC (465–800 V DC)
 - DC voltage 594 V DC
 - Switching frequency 2, 3, 4, or 6 kHz
 - Modulator type 1

Table 150: Power Loss for INU Modules without Options, Modulator Type 1

Model code	Frame	Rated current $I_{L(1/5)}$ [A]	System module, 2 kHz switching frequency		System module, 3 kHz switching frequency		System module, 4 kHz switching frequency		System module, 6 kHz switching frequency		+AKFX ⁽¹⁾ Power loss to air [kW]
			Power loss to liquid [kW]	Power loss to air [kW]	Power loss to liquid [kW]	Power loss to air [kW]	Power loss to liquid [kW]	Power loss to air [kW]	Power loss to liquid [kW]	Power loss to air [kW]	
iC7-60SLINB5-206A	IM10L	206	1.18	0.01	1.39	0.01	1.60	0.02	2.03	0.02	0.04
iC7-60SLINB5-245A		245	1.45	0.01	1.69	0.02	1.94	0.02	2.46	0.02	0.04
iC7-60SLINB5-302A		302	1.87	0.02	2.17	0.02	2.49	0.02	3.17	0.03	0.06
iC7-60SLINB5-385A		385	2.58	0.03	2.99	0.03	3.42	0.03	4.37	0.04	0.09
iC7-60SLINB5-416A		416	2.88	0.03	3.33	0.03	3.81	0.04	4.88	0.05	0.10
iC7-60SLINB5-525A	IM12L	525	3.15	0.03	3.65	0.04	4.19	0.04	5.33	0.05	0.10
iC7-60SLINB5-590A		590	3.64	0.04	4.22	0.04	4.84	0.05	6.16	0.06	0.12
iC7-60SLINB5-650A		650	4.18	0.04	5.79	0.06	5.47	0.05	6.97	0.07	0.14
iC7-60SLINB5-730A		730	4.80	0.05	5.57	0.06	6.37	0.06	8.13	0.08	0.16
iC7-60SLINB5-820A		820	5.63	0.06	6.52	0.07	7.44	0.07	9.58	0.10	0.20
iC7-60SLINB5-1060	2xIM12 L	1060	6.37	0.06	7.43	0.07	8.51	0.09	10.79	0.11	0.20
iC7-60SLINB5-1230		1230	7.67	0.08	8.94	0.09	10.22	0.10	12.98	0.13	0.26
iC7-60SLINB5-1400		1400	9.08	0.09	10.54	0.11	12.06	0.12	15.34	0.15	0.26
iC7-60SLINB5-1500		1500	9.96	0.10	11.55	0.12	13.23	0.13	16.87	0.17	0.31
iC7-60SLINB5-1640		1640	11.27	0.11	13.03	0.13	14.87	0.15	19.15	0.19	0.41
iC7-60SLINB5-1795	3xIM12 L	1795	11.11	0.11	12.90	0.13	14.76	0.15	18.77	0.19	0.38
iC7-60SLINB5-2080		2080	13.45	0.13	15.62	0.16	17.84	0.18	22.76	0.23	0.43
iC7-60SLINB5-2300		2300	15.40	0.15	17.84	0.18	20.42	0.20	26.06	0.26	0.52
iC7-60SLINB5-2500		2460	17.29	0.17	20.00	0.20	22.88	0.23	29.30	0.29	0.65
iC7-60SLINB5-2830	4xIM12 L	2830	18.42	0.18	21.34	0.21	24.46	0.24	31.18	0.31	0.58
iC7-60SLINB5-3050		3050	20.38	0.20	23.61	0.24	26.97	0.27	34.49	0.34	0.70
iC7-60SLINB5-3260		3260	22.34	0.22	25.90	0.26	29.66	0.30	37.98	0.38	0.79

1) DC fuses

10.7.23 Power Losses of INU Modules without Options, Voltage Class B5, Modulator Type 6 – Optimized

- The specifications for the values in the table
 - Inverter module
 - 380–500 V AC (465–800 V DC)
 - DC voltage 594 V DC
 - Switching frequency 2, 3, 4, or 6 kHz
 - Modulator type 6

Table 151: Power Loss for INU Modules without Options, Modulator Type 6

Model code	Frame	Rated current $I_{L(1/5)}$ [A]	System module, 2 kHz switching frequency		System module, 3 kHz switching frequency		System module, 4 kHz switching frequency		System module, 6 kHz switching frequency		+AKFX ⁽¹⁾
			Power loss to liquid [kW]	Power loss to air [kW]	Power loss to liquid [kW]	Power loss to air [kW]	Power loss to liquid [kW]	Power loss to air [kW]	Power loss to liquid [kW]	Power loss to air [kW]	Power loss to air [kW]
iC7-60SLINB5-206A	IM10L	206	1.05	0.01	1.25	0.01	1.33	0.01	1.60	0.02	0.04
iC7-60SLINB5-245A		245	1.29	0.01	1.53	0.02	1.62	0.02	1.94	0.02	0.04
iC7-60SLINB5-302A		302	1.67	0.02	1.98	0.02	2.08	0.02	2.49	0.02	0.06
iC7-60SLINB5-385A		385	2.30	0.02	2.72	0.03	2.86	0.03	3.42	0.03	0.09
iC7-60SLINB5-416A		416	2.57	0.03	3.04	0.03	3.19	0.03	3.81	0.04	0.10
iC7-60SLINB5-525A	IM12L	525	2.81	0.03	3.32	0.03	3.51	0.04	4.19	0.04	0.10
iC7-60SLINB5-590A		590	3.24	0.03	3.84	0.04	4.04	0.04	4.84	0.05	0.12
iC7-60SLINB5-650A		650	3.67	0.04	4.41	0.04	4.59	0.05	5.47	0.05	0.14
iC7-60SLINB5-730A		730	4.29	0.04	5.07	0.05	5.33	0.05	6.37	0.06	0.16
iC7-60SLINB5-820A		820	5.04	0.05	5.95	0.06	6.26	0.06	7.44	0.07	0.20
iC7-60SLINB5-1060	2 x IM12L	1060	5.67	0.06	6.72	0.07	7.11	0.07	8.51	0.09	0.20
iC7-60SLINB5-1230		1230	6.86	0.07	8.09	0.08	8.54	0.09	10.22	0.10	0.26
iC7-60SLINB5-1400		1400	8.10	0.08	9.58	0.10	10.10	0.10	12.06	0.12	0.26
iC7-60SLINB5-1500		1500	8.91	0.09	10.51	0.11	11.07	0.11	13.23	0.13	0.31
iC7-60SLINB5-1640		1640	10.07	0.10	11.90	0.12	12.51	0.13	14.87	0.15	0.41
iC7-60SLINB5-1795	3 x IM12L	1795	9.90	0.10	11.72	0.12	12.36	0.12	14.76	0.15	0.38
iC7-60SLINB5-2080		2080	12.02	0.12	14.19	0.14	14.96	0.15	17.84	0.18	0.43
iC7-60SLINB5-2300		2300	13.76	0.14	16.25	0.16	17.06	0.17	20.42	0.20	0.52
iC7-60SLINB5-2500		2460	15.44	0.15	18.27	0.18	19.16	0.19	22.88	0.23	0.65
iC7-60SLINB5-2830	4 x IM12L	2830	16.46	0.16	19.43	0.19	20.46	0.20	24.46	0.24	0.58
iC7-60SLINB5-3050		3050	18.17	0.18	21.52	0.22	22.57	0.23	26.97	0.27	0.70
iC7-60SLINB5-3260		3260	20.06	0.20	23.60	0.24	24.86	0.25	29.66	0.30	0.79

1) DC fuses

10.7.24 Power Losses of INU Modules with +AES1, Voltage Class 07

- The specifications for the values in the table
 - Inverter module
 - 525–690 V AC (640–1100 V DC)
 - DC voltage 1025 V DC
 - Option +AES1
 - Switching frequency 8 kHz
 - Modulator type 6
 - Motor cable length a maximum of 100 m (328 ft)

Table 152: Power Losses of INU Modules with +AES1 the Sine-wave Filter, Voltage Class 07

Model code	Frame ⁽¹⁾	I _L [A]	System module		System module with +AES1		DC fuses +AKFX [kW]	Standby loss [kW]
			Power loss to liquid [kW]	Power loss to air [kW]	Power loss to liquid [kW]	Power loss to air [kW]		
iC7-60SLIN07-465A	IM12L/ IR12L	465	5.96	0.06	6.70	0.14	0.07	0.131
iC7-60SLIN07-525A		525	6.92	0.07	7.79	0.17	0.10	0.131
iC7-60SLIN07-590A		590	8.03	0.08	9.07	0.20	0.12	0.131
iC7-60SLIN07-650A		650	9.16	0.09	10.42	0.23	0.14	0.131
iC7-60SLIN07-730A		730	10.83	0.11	12.40	0.28	0.16	0.131
iC7-60SLIN07-945A	2 x IM12L/2 x IR12L	945	12.18	0.12	13.69	0.29	0.15	0.262
iC7-60SLIN07-1060		1060	13.98	0.14	15.75	0.34	0.20	0.262
iC7-60SLIN07-1230		1230	17.02	0.17	19.27	0.42	0.26	0.262
iC7-60SLIN07-1400		1400	20.36	0.21	23.27	0.53	0.26	0.262
iC7-60SLIN07-1795	3 x IM12L/3 x IR12L	1795	24.53	0.25	27.73	0.60	0.38	0.393
iC7-60SLIN07-2080		2080	30.17	0.30	34.44	0.78	0.43	0.393
iC7-60SLIN07-2830	4 x IM12L/4 x IR12L	2830	41.41	0.42	47.33	1.08	0.58	0.524
iC7-60SLIN07-3500	5 x IM12L/5 x IR12L	3500	50.91	0.51	58.16	1.32	0.72	0.655
iC7-60SLIN07-4400	6 x IM12L/6 x IR12L	4400	65.51	0.66	74.93	1.71	0.94	0.786

1) IR12L with option +AES1

10.7.25 Power Losses of INU Modules with +AES1, Voltage Class B5

- The specifications for the values in the table
 - Inverter module
 - 380–500 V AC (465–800 V DC)
 - DC voltage 594 V DC
 - Option +AES1
 - Switching frequency 8 kHz
 - Modulator type 6
 - Motor cable length a maximum of 100 m (328 ft)

Table 153: Power Losses of INU Modules with +AES1 the Sine-wave Filter, Voltage Class B5

Model code	Frame ⁽¹⁾	I _L [A]	System module		System module with +AES1		DC fuses +AKFX [kW]	Standby loss [kW]
			Power loss to liquid [kW]	Power loss to air [kW]	Power loss to liquid [kW]	Power loss to air [kW]		
iC7-60SLINB5-525A	IM12L/ IR12L	525	4.51	0.05	5.18	0.12	0.10	0.07
iC7-60SLINB5-590A		590	5.19	0.05	6.01	0.14	0.12	0.07
iC7-60SLINB5-650A		658	5.94	0.06	6.95	0.17	0.14	0.07
iC7-60SLINB5-730A		730	6.81	0.07	8.04	0.21	0.16	0.07
iC7-60SLINB5-1060	2 x IM12L/2 x IR12L	1060	9.11	0.09	10.46	0.24	0.20	0.14
iC7-60SLINB5-1230		1230	10.94	0.11	12.72	0.31	0.26	0.14
iC7-60SLINB5-1400		1400	12.88	0.13	15.16	0.38	0.26	0.14
iC7-60SLINB5-1795	3 x IM12L/3 x IR12L	1795	15.81	0.16	18.34	0.44	0.38	0.22
iC7-60SLINB5-2080		2080	19.11	0.19	22.47	0.57	0.43	0.22
iC7-60SLINB5-2830	4 x IM12L	2830	26.16	0.26	30.81	0.78	0.58	0.29

1) IR12L with option +AES1

10.7.26 Power Losses of DC/DC Converter Modules, Voltage Class 07

- The specifications for the values in the table
 - DC/DC converter module
 - DC voltage 1025 V DC
 - Default switching frequency
 - Power losses at rated low overload current I_L, 50% duty cycle

Table 154: Power Loss for DC/DC Converter Modules

Product code	Frame ⁽¹⁾	Nominal current I _L [A]	System module		System module with +AED1 ⁽²⁾		DC fuses +AKFF ⁽³⁾ [kW]	Standby loss [kW]
			Power loss to liquid [kW]	Power loss to air [kW]	Power loss to liquid [kW]	Power loss to air [kW]		
iC7-60SLDC07-300A	DM10L/ DR10L	300	2.59	0.03	2.92	0.07	0.08	0.07
iC7-60SLDC07-360A		360	3.14	0.03	3.52	0.09	0.11	0.07
iC7-60SLDC07-420A		420	3.74	0.04	4.18	0.11	0.13	0.07
iC7-60SLDC07-480A		480	3.82	0.04	4.38	0.13	0.14	0.07
iC7-60SLDC07-570A		570	4.07	0.04	4.86	0.14	0.19	0.13
iC7-60SLDC07-720A	DM12L/ DR12L	720	4.76	0.05	5.76	0.18	0.24	0.13
iC7-60SLDC07-840A		840	5.63	0.06	6.95	0.23	0.31	0.13
iC7-60SLDC07-960A		960	6.57	0.07	8.27	0.29	0.33	0.13
iC7-60SLDC07-1080		1080	7.59	0.08	9.73	0.36	0.34	0.13
iC7-60SLDC07-1200		1200	8.71	0.09	11.34	0.43	0.45	0.13

Table 154: Power Loss for DC/DC Converter Modules - (continued)

Product code	Frame ⁽¹⁾	Nominal current I_L [A]	System module		System module with +AED1 ⁽²⁾		DC fuses +AKFF ⁽³⁾ [kW]	Standby loss [kW]
			Power loss to liquid [kW]	Power loss to air [kW]	Power loss to liquid [kW]	Power loss to air [kW]		
iC7-60SLDC07-1440	2 x DM12L/2 x DR12L	1440	9.51	0.10	11.53	0.35	0.46	0.26
iC7-60SLDC07-1680		1680	11.26	0.11	13.90	0.45	0.60	0.26
iC7-60SLDC07-1920		1920	13.14	0.13	16.53	0.56	0.68	0.26
iC7-60SLDC07-2160		2160	15.19	0.15	19.46	0.70	0.69	0.26
iC7-60SLDC07-2400		2400	17.41	0.18	22.68	0.85	0.81	0.26
iC7-60SLDC07-2880	3 x DM12L/3 x DR12L	2880	19.71	0.20	24.80	0.87	1.02	0.26
iC7-60SLDC07-3240		3240	22.78	0.23	29.19	1.04	1.03	0.39
iC7-60SLDC07-3600		3600	26.12	0.26	34.02	1.25	1.21	0.39

1) DR1xL with option +AED1

2) +AED1 = LC Filter

3) +AKFF = DC-bus fuses and source fuses

10.7.27 Power Losses of DC/DC Converter Modules, Voltage Class B5

- The specifications for the values in the table
 - DC/DC converter module
 - DC voltage 594 V DC
 - Default switching frequency
 - Power losses at rated low overload current I_L , 50% duty cycle

Table 155: Power Loss for DC/DC Converter Modules

Product code	Frame ⁽¹⁾	Nominal current I_L [A]	System module		System module with +AED1 ⁽²⁾		DC fuses +AKFF ⁽³⁾ [kW]	Standby loss [kW]
			Power loss to liquid [kW]	Power loss to air [kW]	Power loss to liquid [kW]	Power loss to air [kW]		
iC7-60SLDCB5-300A	DM10L/DR10L	300	1.62	0.02	1.79	0.05	0.08	0.04
iC7-60SLDCB5-360A		360	1.93	0.02	2.15	0.06	0.11	0.04
iC7-60SLDCB5-420A		420	2.26	0.02	2.53	0.07	0.13	0.04
iC7-60SLDCB5-480A		480	2.60	0.03	2.94	0.09	0.14	0.04
iC7-60SLDCB5-570A		570	3.17	0.03	3.62	0.10	0.19	0.04
iC7-60SLDCB5-720A	DM12L/DR12L	720	3.48	0.04	4.09	0.12	0.24	0.07
iC7-60SLDCB5-840A		840	4.07	0.04	4.90	0.16	0.31	0.07
iC7-60SLDCB5-960A		960	4.70	0.05	5.78	0.20	0.33	0.07
iC7-60SLDCB5-1080		1080	5.36	0.05	6.74	0.26	0.34	0.07
iC7-60SLDCB5-1200		1200	6.07	0.06	7.79	0.30	0.45	0.07

Table 155: Power Loss for DC/DC Converter Modules - (continued)

Product code	Frame ⁽¹⁾	Nominal current I _L [A]	System module		System module with +AED1 ⁽²⁾		DC fuses +AKFF [kW] ⁽³⁾	Standby loss [kW]
			Power loss to liquid [kW]	Power loss to air [kW]	Power loss to liquid [kW]	Power loss to air [kW]		
iC7-60SLDCB5-1440	2 x DM12L/2 x DR12L	1440	6.95	0.07	8.18	0.24	0.46	0.14
iC7-60SLDCB5-1680		1680	8.14	0.08	9.79	0.31	0.60	0.14
iC7-60SLDCB5-1920		1920	9.39	0.09	11.55	0.39	0.68	0.14
iC7-60SLDCB5-2160		2160	10.72	0.11	13.48	0.49	0.69	0.14
iC7-60SLDCB5-2400		2400	12.13	0.12	15.57	0.59	0.81	0.14
iC7-60SLDCB5-2880	3 x DM12L/3 x DR12L	2880	14.09	0.14	17.33	0.61	1.02	0.22
iC7-60SLDCB5-3240		3240	16.08	0.16	20.22	0.72	1.03	0.22
iC7-60SLDCB5-3600		3600	18.20	0.18	23.36	0.86	1.21	0.22

1) DR1xL with option +AED1

2) +AED1 = LC Filter

3) +AKFF = DC-bus fuses and source fuses

10.7.28 Power Losses of BCU Modules, Voltage Class B5, 500 V AC, 800 V DC

Table 156: Power Losses of BCU Modules, Voltage Class B5

Model code	Frame	BCU system module			DC-fuses (Option +AKFX)	Standby loss
		Rated current I _L [A]	Power loss to liquid [kW]	Power loss to air [kW]	Power loss to air [kW]	Power loss to air [kW]
iC7-60SLBRB5-170A	BM10L	170	0.75	0.01	0.03	0.04
iC7-60SLBRB5-261A		261	1.21	0.01	0.05	0.04
iC7-60SLBRB5-416A		416	2.08	0.02	0.10	0.04
iC7-60SLBRB5-525A	BM12L	525	2.43	0.02	0.10	0.07
iC7-60SLBRB5-650A		650	3.10	0.03	0.14	0.07
iC7-60SLBRB5-820A		820	4.08	0.04	0.20	0.07
iC7-60SLBRB5-1060	2 x BM12L	1060	4.23	0.04	0.20	0.14
iC7-60SLBRB5-1400		1400	6.75	0.07	0.26	0.14
iC7-60SLBRB5-1640		1640	8.17	0.08	0.26	0.14

10.7.29 Power Losses of BCU Modules, Voltage Class 07, 690 V AC, 1100 V DC

Table 157: Power Losses of BCU Modules, Voltage Class 07

Model Code	Frame	Brake chopper module			DC-fuses (Option +AKFX)	Standby loss
		Rated current I_L [A]	Power loss to liquid [kW]	Power loss to air [kW]	Power loss to air [kW]	Power loss to air [kW]
iC7-60SLBR07-170A	BM10L	170	0.90	0.01	0.03	0.07
iC7-60SLBR07-261A		261	1.43	0.01	0.05	0.07
iC7-60SLBR07-416A		416	2.45	0.02	0.10	0.07
iC7-60SLBR07-525A	BM12L	525	2.86	0.03	0.10	0.13
iC7-60SLBR07-650A		650	3.65	0.04	0.14	0.13
iC7-60SLBR07-820A		820	4.80	0.05	0.20	0.13
iC7-60SLBR07-1060	2 x BM12L	1060	5.80	0.06	0.20	0.26
iC7-60SLBR07-1400		1400	7.97	0.08	0.26	0.26
iC7-60SLBR07-1640		1640	9.60	0.10	0.41	0.26

10.8 Technical Data

Table 158: Mains Connection

Technical item or function	Technical data
Input voltage U_{in}	Voltage class 07: 3 x 525–690 V AC (-15...+10%) Voltage class B5: 3 x 380–500 V AC (-15...+10%) Voltage class G7: 3 x 380–690 V AC (-15...+10%) Voltage class A5: 3 x 380–500 V AC (-15...+10%)
Protective Class	Class I
Input frequency	45–66 Hz for AFE/GC 25–70 Hz for GC. Low frequency operation below 45 Hz with derating of 0.2%/Hz
Default switching frequency, AFE/GC	Voltage class A5: Frame size Ax10L: 10 kHz Frame size Ax12L: 8 kHz Voltage class B5, 07: 8 kHz Voltage class G7: 8 kHz, minimum 7.6 kHz
Mains network	TN-S, TN-C, IT and TT. Supply voltage limited to 500 V AC for corner grounded networks, Wye/Delta.
Power factor	$\cos \varphi = 1$: (fundamental) (AFE) $\cos \varphi = 0$ ind. to 0 cap: (fundamental) (GC)
Total harmonics distortion THDi (Nominal situation and undistorted network. The total load balance of the system affects this value.)	AFE/GC modules: < 5% AFE/GC modules with a dedicated transformer: < 3%
Short-circuit current rating, with the specified fuses	The maximum short circuit current $I_{cc} \leq 100$ kA

Table 158: Mains Connection - (continued)

Technical item or function	Technical data
Overvoltage category	Category III
Imbalance	Nominal performance with voltage imbalance $\leq 3\%$. Derated performance with $>3\%$ voltage imbalance. Grid Converter maximum imbalanced load: 40% of S_n (nominal power)
Connections to mains	Once every 60 s for 5 minutes, then pause of 10 minutes

Table 159: Motor Connection

Technical item or function	Technical data
Output voltage	0– U_{in} , 3-phase
Output frequency	0–590 Hz
Switching frequency, INU	1.5–10 kHz Voltage class A5: 5 kHz Voltage class B5 and 07: 3 kHz Default: 8 kHz with Sine-wave Filter OF7S1SM (+AES1)
Field weakening point	1–600 Hz
Motor control principles	U/f control VVC+ (Vector Voltage Control) Flux Vector Control
Motor and generator types supported	Induction/asynchronous motor Non-Salient Permanent Magnet Motor Salient Permanent Magnet Motor Synchronous Reluctance Assisted Permanent Magnet Motor
Torque control, torque step rise time	Open loop: <5 ms with nominal torque and <1 ms with nominal torque with AFE supply Closed loop: <5 ms with nominal torque and <1 ms with nominal torque with AFE supply
Torque control, static accuracy	Open loop: $<2\%$ of motor nominal torque up to nominal speed and $<4\%$ of motor nominal torque in the field weakening area Closed loop: $<2\%$ of motor nominal torque up to nominal speed and $<4\%$ of motor nominal torque in the field weakening area
Speed control, static accuracy	Open loop: 5% of motor nominal slip up to motor nominal motor frequency and 10% of motor nominal slip in the field weakening area Closed loop: 0.01% static error of nominal speed with encoder PPR of 1024 or better
Speed control, dynamic accuracy (response)	Open loop: 0.2–0.4 s with nominal torque step Closed loop: 0.1–0.2 s with nominal torque step
Motor control resolution	Reference setpoint resolution 31 bit + sign
Cable length	Up to 150 m (492 ft) symmetrical and shielded motor cable. See the cable restrictions for filters in 7.13.1 dU/dt Filter and 7.13.2 Common-mode Filter .

Table 159: Motor Connection - (continued)

Technical item or function	Technical data
Cable length sine-wave filter	100 m (328 ft) at grounded network.
Cable length SISO filter	Maximum cable length is 400 m (1312 ft) if the SISO filter is installed at only 1 end (either AFE or at INU). Cable length greater than 2000 m (> 6562 ft) are achievable when the SISO filters are installed at both the AFE and INU.

Table 160: DC-bus Connection

Technical item or function	Technical data
Nominal DC-bus voltage	Voltage class A5: 594 V DC (400 V AC), 742 V DC (500 V AC) Voltage class 07: 1025 V DC Voltage class B5: 742 V DC
DC-bus voltage range	Voltage class B5, A5: 425–830 V DC (-0...+0%) GC, DC/DC: Start-up and short-term operation 350–425 V DC Voltage class 07: 640–1100 V DC (-0...+0%) DC/DC: Start-up and short-term operation 350–640 V DC Voltage class G7: 500–1500 V DC (-0...+0%)
Capacitance	Voltage class A5: xx10L: 3600 μ F xx12 L: 7200 μ F Voltage class B5, 07: xx10L: 1600 μ F xx12L: 3200 μ F AR12L (G7): 2280 μ F
DC short-circuit current rating, with the specified fuses	Voltage class A5/B5/07: I_{cc} 100 kA Voltage class G7: I_{cc} 120 kA (250 kA ⁽¹⁾) The time constant L/R of the fault loop impedance must be <3 ms with specified fuses.
Overvoltage category	Up to 1250 V: Category II 1250–1500 V: Category I 1250–1500 V with external monitored surge-protection device (max. 6 kV): Category II

1) Validation pending.

Table 161: DC/DC Converter DC-source Connection

Technical item or function	Technical data
Source voltage range	3–100% of DC-bus voltage with limited control performance 3–97% of DC-bus voltage with full control performance
Maximum short-circuit current from DC source	Up to 100 kA if the time constant L/R of the fault loop impedance <15 ms. Valid for recommended fuse selection. Consult Danfoss for fuse selection if L/R >15 ms.
Source current ripple with DC filter (+AED1/OF7D1)	DR10L/DC10L: AC RMS <1% of I_N RMS typical DR12L/DC12L: AC RMS <0.5% of I_N RMS typical

Table 161: DC/DC Converter DC-source Connection - (continued)

Technical item or function	Technical data
Default switching frequency	07, B5: <ul style="list-style-type: none"> DM10L/DR10L 300 A, 360 A, 420 A: 8 kHz DM10L/DR10L 480 A: 7 kHz DM10L/DR10L 570 A: 6 kHz DM12L/DR12L: 6 kHz
DC/DC Converter control principles	DC-bus voltage reference Source voltage reference Source power and current references Current and voltage limit controllers

Table 162: Control Electronic Connection

Technical item or function	Technical data
Input voltage U_{in}	24 V DC (20.4–28.8 V), DVC As (not for use in wet locations), minimum power 20 W Ground = negative polarity grounded via the electronics For details, see 8.1 Modular Control Unit .

Table 163: Ambient Conditions

Technical item or function	Technical data
Protection rating	IP00/NEMA/UL Open Type
Surrounding operating temperature	Voltage class A5: -15 (no frost)...+60 °C (5...140 °F), except -15...55 °C (5...131 °F) at I_N (nominal) for: <ul style="list-style-type: none"> INU, voltage class A5, current ratings: 520 A, 1000 A, 1960 A, 2880 A, 3820 A, 4750 A, 5680 A. AFE/GC, voltage class A5, current ratings: 460 A, 970 A, 1900 A, 2800 A, 3720 A, 4650 A, 5550 A, 6450 A, 7370 A. Voltage class B5, 07: -15 (no frost)...+60 °C (5...140 °F) at I_N Voltage class G7: -15 (no frost)...+50 °C (5...122 °F) at I_N , maximum 60 °C (140 °F), derate output current 1%/1 °C above 50 °C (122 °F) Control units: -15 (no frost)...+55 °C (5...131 °F) at I_N Glycol to be used in the coolant when temperature is under 0 °C (32 °F). Freezing not allowed.
Installation temperature	-10...+70 °C (14...158°F)
Storage/transportation temperature	-40...+70 °C (-40...158°F) No coolant allowed in modules during storage/transportation.
Relative humidity	5–95% RH, no condensation, no dripping water
Environmental conditions storage (IEC 60721-3-1)	Climatic conditions: Class 1K21 Chemically active substances: Class 1C2 Biological conditions: Class 1B1 Mechanical conditions: Class 1M11 Mechanically active substances: Class 1S12

Table 163: Ambient Conditions - (continued)

Technical item or function	Technical data
Environmental conditions for transportation (IEC 60721-3-2)	Climatic conditions: Class 2K11 Chemically active substances: Class 2C2 Biological conditions: Class 2B1 Mechanical conditions: Class 2M5 Mechanically active substances: Class 2S5
Environmental conditions operation (IEC 60721-3-3)	Climatic conditions: Class 3K22 Chemically active substances: IEC 60721-3-3 Edition 3.0/ISO 9223-Second Edition, class C4 Biological conditions: Class 3B1 Mechanically active substances: Class 3S6 Special climatic conditions (heat radiation): Class 3Z1
Pollution degree	Power units: PD3 Control units: PD2
Altitude	0–4000 m (0–13000 ft) above sea level, when the network is not corner grounded: Voltage class B5 and A5 0–3000 m (0–10000 ft) above sea level: Voltage class 07 without AFE supply 0–2000 m (0–6500 ft): Voltage class 07 with AFE supply, voltage class G7 Above 1000 m (3280 ft): Derating of maximum surrounding operating temperature by 0.5 °C per each 100 m (0.9 °F per each 330 ft) is required.
Vibration (IEC 60068-2-6) <ul style="list-style-type: none"> • IEC/EN 61800-5-1 • IEC/EN 62477-1 • IACS UR E10 	Testing was performed according to IEC/EN 61800-5-1 and IEC/EN 62477-1, with these specifications: <ul style="list-style-type: none"> • Frequency range 5–150 Hz • Amplitude ± 0.5 mm, 5–22.29 Hz • Constant peak acceleration 10 m/s^2 ($1 g_n$), 22.29–150 Hz Testing was performed according to IACS UR E10, with these specifications: <ul style="list-style-type: none"> • Frequency range 2–100 Hz • Amplitude ± 1.0 mm, 2–13.2 Hz • Constant peak acceleration 7 m/s^2 ($0.7 g_n$), 13.2–100 Hz with maximum amplification of 5
Shock (IEC 60068-2-27)	Maximum 5 g, 30 ms

Table 163: Ambient Conditions - (continued)

Technical item or function	Technical data
Sound pressure level SPL ⁽¹⁾ <div style="background-color: yellow; padding: 5px; display: inline-block; text-align: center;"> CAUTION </div> <ul style="list-style-type: none"> When acoustic noise level is >70 dB(A), use hearing protection. 	<ul style="list-style-type: none"> IM10L, AM10L, IR10L, AR10L, IR12L, AR12L: 70 dB(A) DM10L, DM12L, DR10L, DR12L: max. 87 dB(A) at worst case operation point AR12L G7 voltage class: 62 dB(A) 2 modules in parallel: +3 dB(A) 3 modules in parallel: +4.8 dB(A) 4 modules in parallel: +6 dB(A) 5 modules in parallel: +7 dB(A) 6 modules in parallel: +7.8 dB(A) 7 modules in parallel: +8.5 dB(A) 8 modules in parallel: +9 dB(A)
Sound power level SWL ⁽¹⁾⁽²⁾	<ul style="list-style-type: none"> AR12L G7 voltage class: 67 dB(A) 2 modules in parallel: +3 dB(A) 3 modules in parallel: +4.8 dB(A) 4 modules in parallel: +6 dB(A) 5 modules in parallel: +7 dB(A) 6 modules in parallel: +7.8 dB(A) 7 modules in parallel: +8.5 dB(A) 8 modules in parallel: +9 dB(A)

1) Measured at a distance of 1 m (3.3 ft), the product in a reference cabinet with the doors closed.

2) Measured according to ISO 3476:2010.

Table 164: EMC

Technical item or function	Technical data
Immunity	Fulfills IEC/EN 61800-3, 2nd environment Fulfills IEC/EN 61000-6-2
Emissions	Motor drives (AFE, INU): IEC/EN 61800-3, category C3, if the drive is installed according to manufacturer instructions. The EMC category can be changed to C4 for IT type mains. Power Converters (GC, DC/DC): CISPR11/EN 55011 (Class A, Group 1)

Table 165: Protections

Technical item or function	Technical data
Overvoltage trip limit	Voltage class 07: 1250 V DC Voltage class B5 and A5: 911 V DC Voltage class G7: 1600 V DC
Undervoltage trip limit	Set by parameter Unit Voltage Class Voltage class B5 and A5: Class 13, mains voltage 380–500 V AC: 334 V DC Class 1, mains voltage 380–440 V AC: 334 V DC Class 2, mains voltage 440–480 V AC: 334 V DC Class 3, mains voltage 480–500 V AC: 447 V DC Voltage class 07: Class 13, mains voltage 525–690 V AC: 334 V DC Class 1, mains voltage 525 V AC: 334 V DC Class 2, mains voltage 600 V AC: 447 V DC Class 3, mains voltage 690 V AC: 696 V DC For detailed voltage class descriptions, refer to the relevant application guide.
Ground fault protection	In TN and TT networks. Fulfills the requirements of IEC 60364-4-41 + AMD1, 411. Not available for DC/DC converter modules.
Missing phase supervision	Yes
Overcurrent protection	Yes
Unit overtemperature protection	Yes
Motor overload protection	Yes
Motor stall protection	Yes
Motor underload protection	Yes

Table 166: Product Compliance

Technical item or function	Technical data
Conformity	CE, RCM, UA. See the product label for more approvals.
Safety Standards	IEC/EN 61800-5-1 IEC/EN 62477-1
Functional safety	STO/SS1-t with option +BEF2. See iC7 Series Functional Safety Operating Guide, Air-cooled and Liquid-cooled System Modules .
Marine type approvals	Voltage class 07 and B5: DNV, ABS, BV, CCS, RINA, LR, KR, NK

Table 167: Efficiency

Technical item or function	Technical data
Efficiency	See 10.7.1 List of Power Loss Information .

Table 168: Liquid Cooling

Technical item or function	Technical data
Temperature of coolant	<p>Voltage class A5: -10...+45 °C (14...113 °F) at I_N (nominal) Except -10...+40 °C (14...104 °F) at I_N(nominal) for:</p> <ul style="list-style-type: none"> • INU, voltage class A5, current ratings 520 A, 1000 A, 1960 A, 2880 A, 3820 A, 4750 A, 5680 A. • AFE/GC, voltage class A5, current ratings 460 A, 970 A, 1900 A, 2800 A, 3720 A, 4650 A, 5550 A, 6450 A, 7370 A. <p>Voltage class 07: -10...+45 °C (14...113 °F) at I_N(nominal) Except -10...+38 °C (14...100 °F) at I_N(nominal) for:</p> <ul style="list-style-type: none"> • INU, voltage class 07 with +AES1/AEZ1, current ratings 730 A, 1400 A, 2080 A, and 2830–4400 A • AFE and GC, voltage class 07, current ratings 380 A, 760 A, 1500 A, 2250 A, 2940 A, 3600 A, 4320 A, 5040 A, 5750 A • DC/DC converter, voltage class 07, current ratings 1200 A, 2400 A, 3600 A <p>45 °C (113 °F) at I_L and overloadability, 38 °C (100 °F) at I_H and overloadability for the INU with sine-wave filter +AES1 or LC-filter +AEZ1.</p> <p>Voltage class G7: -10...+45 °C (14...113 °F) at I_N</p> <p>Temperature rise during circulation:</p> <ul style="list-style-type: none"> • 7 °C (13 °F) for INU • 10 °C (18 °F) for AFE/GC and INU with +AES1/AEZ1 • 5 °C (9 °F) for DC/DC converter and voltage class G7 GC <p>Glycol to be used in coolant below 0 °C (32 °F). Freezing not allowed.</p>
Pressure limits	<p>Recommended default pressure: 100–150 kPa¹⁾ Maximum operating pressure (= Design pressure): 500 kPa Maximum test pressure: 750 kPa</p>
Pressure drop	50–100 kPa at rated volumetric flow
Allowed coolants	<p>Demineralized water or pure water with the quality specified in 6.3.2 Purified Water as Coolant.</p> <p>Ethylene glycol</p> <ul style="list-style-type: none"> • DOWCAL 100 • Clariant Antifrogen N <p>Propylene glycol</p> <ul style="list-style-type: none"> • DOWCAL 200 • Clariant Antifrogen L
Heat sink material	Aluminum

1) The default pressure is the static state pressure without operating the cooling pump. Cooling pump operation increases the pressure typically 100–200 kPa. Do not exceed the maximum operating pressure in any situation.



Danfoss Drives Oy
Runsorintie 7
FIN-65380 Vaasa
danfoss.drives.com

Any information, including, but not limited to information on selection of product, its application or use, product design, weight, dimensions, capacity or any other technical data in product manuals, catalog descriptions, advertisements, etc. and whether made available in writing, orally, electronically, online or via download, shall be considered informative, and is only binding if and to the extent, explicit reference is made in a quotation or order confirmation. Danfoss cannot accept any responsibility for possible errors in catalogs, brochures, videos and other material. Danfoss reserves the right to alter its products without notice. This also applies to products ordered but not delivered provided that such alterations can be made without changes to form, fit or function of the product. All trademarks in this material are property of Danfoss A/S or Danfoss group companies. Danfoss and the Danfoss logo are trademarks of Danfoss A/S. All rights reserved.

AJ475942178716en-010601
Danfoss Drives Oy © 2026.06



1 7 2 K 2 8 4 8 F