



Voltage Measurement Option OC7V0

iC7 Series



Contents

1 Introduction

1.1 Purpose of the Operating Guide	5
1.2 Additional Resources	5
1.3 Version History	5

2 Safety

2.1 Safety Symbols	6
2.2 Safety Awareness	6
2.3 Installation Safety	7

3 Overview

3.1 Voltage Measurement Option OC7V0	8
3.2 Compatibility	9

4 Configuration

4.1 Configuration Overview	10
4.2 Option Slot Addressing in Systems with Modular Control Unit	10

5 Installation

5.1 Verifying the Shipment and the Contents	11
5.2 Items Supplied	11
5.3 Required Tools	11
5.4 Installing Boards to the Modular Control Unit	11
5.5 Installing the Voltage Measurement Option OC7V0	12
5.6 Fiber Cable Requirements	13
5.7 Terminal and Connector Specifications	13
5.8 Installation Example Diagrams	16

6 Application Examples

6.1 Grid Converter Control	17
6.2 Line Filter Energization and Transformer Magnetization	17
6.3 Closed-loop AC Voltage Control	18
6.4 External Grid Synchronization	18

7 Specifications

7.1 Technical Data	19
7.2 Dimensions	20
7.3 Related Standards	20

1 Introduction

1.1 Purpose of the Operating Guide

This operating guide provides information for safe installation, commissioning, and operation of Voltage Measurement Option OC7V0 with iC7 series drives or power converters.

This guide is intended for use by qualified personnel only. To use the drives or power converters safely and professionally, read and follow the operating instructions, and pay particular attention to the safety instructions and general warnings. Always keep this operating guide available with the drive or power converters.

1.2 Additional Resources

Additional resources are available to help understand the features, and safely install and operate the iC7 series products:

- Safety guides, which provide important safety information related to installing iC7 series drives and power converters.
- Installation guides, which cover the mechanical and electrical installation of drives, power converters, or functional extension options.
- Design guides, which provide technical information to understand the capabilities of the iC7 series drives or power converters for integration into motor control and monitoring systems.
- Operating guides, which include instructions for control options, and other components for the drive.
- Application guides, which provide instructions on setting up the drive or power converter for a specific end use. Application guides for application software packages also provide an overview of the parameters and value ranges for operating the drives or power converters, configuration examples with recommended parameter settings, and troubleshooting steps.
- *Facts Worth Knowing about AC Drives*, available for download on www.danfoss.com.
- Other supplemental publications, drawings, and guides are available at www.danfoss.com.

Latest versions of Danfoss product guides are available for download at <https://www.danfoss.com/en/service-and-support/documentation/>.

1.3 Version History

This guide is regularly reviewed and updated. All suggestions for improvement are welcome.

The original language of this guide is English.

Table 1: Version History





Version	Remarks
AN449122783579, version 0201	Updated the information regarding the installation slot selection for the option.
AN449122783579, version 0101	The first version of this guide.

2 Safety

2.1 Safety Symbols

The following symbols are used in Danfoss documentation and products.

 DANGER
Indicates a hazardous situation which, if not avoided, will result in death or serious injury.
 WARNING
Indicates a hazardous situation which, if not avoided, could result in death or serious injury.
 CAUTION
Indicates a hazardous situation which, if not avoided, could result in minor or moderate injury.
NOTICE
Indicates information considered important, but not hazard-related (for example, messages relating to property damage).

	ISO warning symbol for general warnings
	ISO warning symbol for hot surfaces and burn hazard
	ISO warning symbol for high voltage and electric shock
	Symbol for indicating the required discharge time of the capacitors in the product.
	ISO action symbol for referring to the instructions

2.2 Safety Awareness

Before starting installation, read:

- The safety guidelines and precautions related to installing the iC7 series Voltage Measurement Option OC7V0 in this operating guide
- The iC7 series System Modules Safety Guide

Supplemental information and other iC7 series guides can be downloaded from <https://www.danfoss.com/en/service-and-support/documentation/>.

2.3 Installation Safety

DANGER



DISCHARGE TIME

The drive contains DC-link capacitors, which can remain charged even when the drive is not powered. High voltage can be present even when the warning indicator lights are off. Contact with this voltage can cause death or serious injury.

- Disconnect all sources and loads which are connected to the system module.
- Wait for the capacitors to discharge fully before performing any service or repair work. The discharge time is 5 minutes. If any other source is connected, the discharge time can be longer.
- Use a calibrated measuring device to make sure that there is no voltage, before opening the drive or performing any work on the cables.

DANGER



SHOCK HAZARD

The line which is to be connected to the Voltage Measurement Option can have voltage present even when the drive is not powered. Contact with this voltage can cause death or serious injury.

- Disconnect all sources and loads which are connected to the line which is to be connected to the Voltage Measurement Option.
- Use a calibrated measuring device to make sure that there is no voltage, before performing any work on the cables.

3.2 Compatibility

The iC7 series Voltage Measurement Option OC7V0 is compatible with the iC7 series system modules and the modular control unit.

4 Configuration

4.1 Configuration Overview

The parameters related to Voltage Measurement Option OC7V0 are in parameter group 9, called **Option Board Settings**. Parameters depend on the mounting and will appear in the parameter menu after the functional extension has been mounted and wired.

4.2 Option Slot Addressing in Systems with Modular Control Unit

The physical slots 1 and 2 on the modular control unit are reserved for default control unit components. Functional extension options are positioned in the physical slots A–H as shown in [Figure 2](#).

When referred to in the software, the option uses a different name for the software address. The 1st slot position with an installed option is always addressed as 201, the 2nd position as 202, and so on, regardless of which option slot the 1st option is installed in. Software address 101 is reserved for default control unit components.

Table 2: Physical Option Slot and Its Software Address in Systems with Modular Control Unit

Software address	101	101	201	202	203	204	205	206	207	208
Slot	1	2	A	B	C	D	E	F	G	H

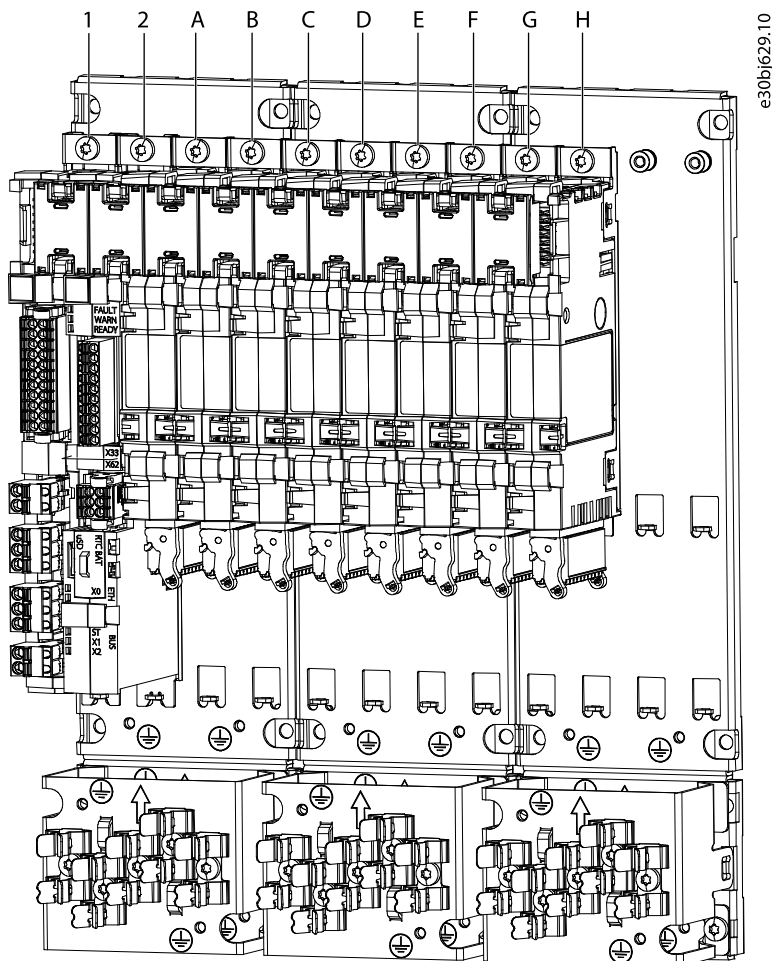

Figure 2: Option Slot Locations in Systems with Modular Control Unit

5 Installation

5.1 Verifying the Shipment and the Contents

Make sure that the items supplied and the information on the product label correspond to the order confirmation. The product label is placed on the front and right side of the option casing.

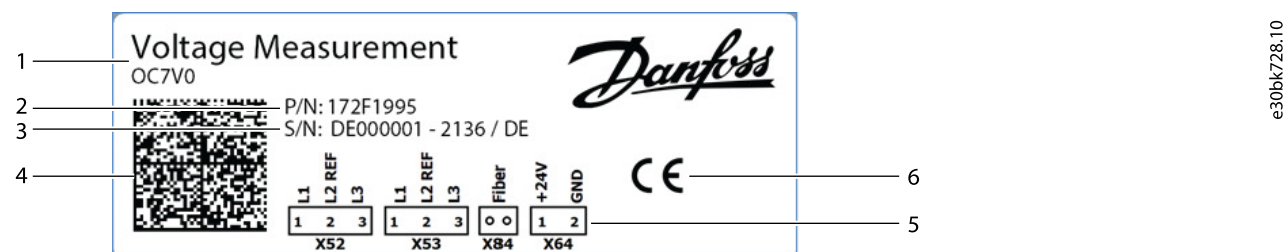

Figure 3: Example of a Product Label

1	Product name	2	Code number
3	Serial number	4	2D code which can be used to access detailed product information via MyDrive® tools
5	Identification of I/O connections on the option	6	Compliance and approval markings

5.2 Items Supplied

The Voltage Measurement Option OC7V0 can be ordered as a separate option for field mounting by using the code number.

When the Voltage Measurement Option OC7V0 is not mounted at the factory, the following items are included in the shipment:

- Voltage Measurement Option OC7V0
- DIN rail 35 x 7.5 x 150 mm (1.38 x 0.30 x 5.91 in)
- LC/LC duplex multimode patch cable, length: 5 m (16 ft)
- Option Extender OC7F2
- Option connector

5.3 Required Tools

The required tools for the installation are:

- Flathead screwdriver (the recommended size of the head is 0.3 x 2.5 mm)
- Torx screwdriver (size TX20)
- Wire crimper

5.4 Installing Boards to the Modular Control Unit

NOTICE

DAMAGE TO OPTION BOARDS

Do not install, remove, or replace option boards on the drive when the power is on. Doing this can cause damage to the boards.

- Switch off the drive before installing, removing, or replacing option boards on the drive.

! IMPORTANT: It is recommended to install Option Extender OC7F2 in the 2nd slot on the right of the control unit.

1. Remove the screw that is pre-attached to the fixing point at the top of the mounting plate and keep it.
2. Slide the lower edge of the board to the mounting plate fixing point.

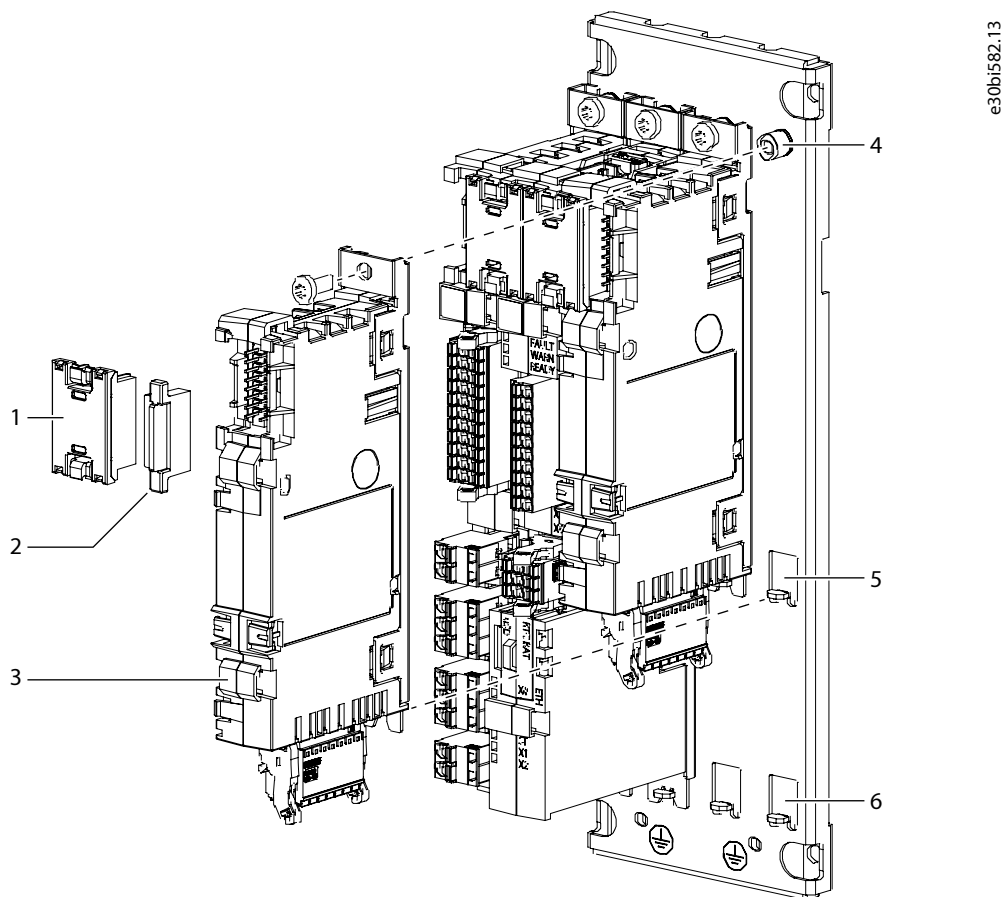

Figure 4: Installing a Board to the Modular Control Unit Mounting Plate

1	Option connector	2	Option terminal cover
3	Option board	4	Fixing point at the top
5	Fixing point at the middle	6	Fixing point at the bottom

3. Use the screw to attach the board to the fixing point at the top.
4. Attach an option connector to the installed board and the board next to it.
5. Attach option terminal covers to the empty terminals.

5.5 Installing the Voltage Measurement Option OC7V0

1. Mount the DIN rail close to the location of the voltage to be measured.

The DIN rail is included in the delivery of the Voltage Measurement Option OC7V0.

2. Mount the voltage measurement option on the DIN rail so that the terminals are in the bottom.
 - a. Lower the voltage measurement option on the DIN rail from above.
 - b. Snap the bottom part of the voltage measurement option on the DIN rail.

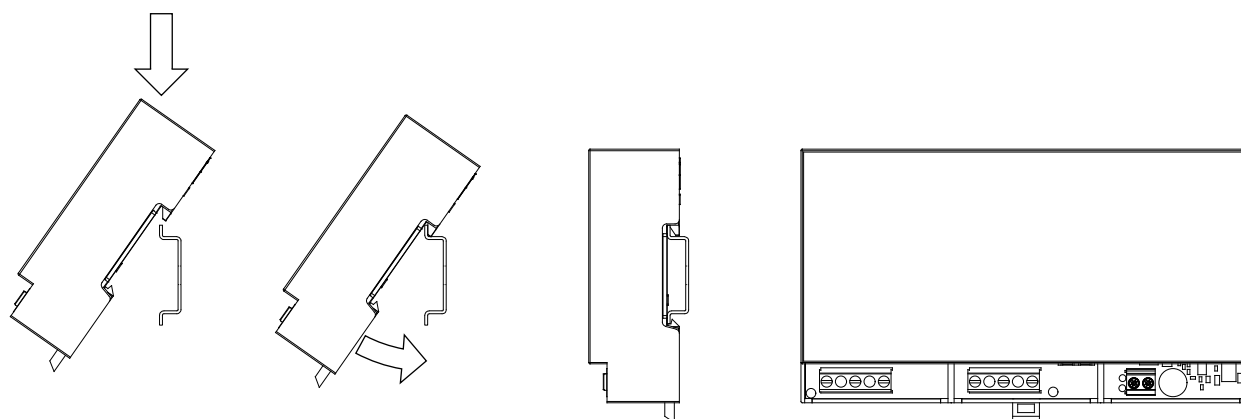

e30b1332.10

Figure 5: Mounting the Voltage Measurement Option

3. Connect the fiber cable for the communication between the option extender and the voltage measurement option. See [5.7 Terminal and Connector Specifications](#).

The delivery includes a 5 m (16 ft) long fiber cable and longer cables can be ordered separately. Make sure that the fiber length does not exceed the maximum of 20 m (65 ft).

4. Connect the 24 V supply cable from the option extender to the voltage measurement option. See [5.7 Terminal and Connector Specifications](#).
5. Make sure that the wiring between the voltage measurement option and the option extender is sufficiently protected against environmental stress. Make sure that all wiring complies with local and national regulations regarding the cross-section and ambient temperatures.
6. Connect the wiring to the voltage to be measured. See [5.8 Installation Example Diagrams](#).

5.6 Fiber Cable Requirements

The required fiber cable type is LC duplex cable assembly 0.5NA SI-POF.

The installation temperature of the fiber cable is $-40\dots+85\text{ }^{\circ}\text{C}$ ($-40\dots+185\text{ }^{\circ}\text{F}$). The minimum bending radius is 25 mm (1.0 in).

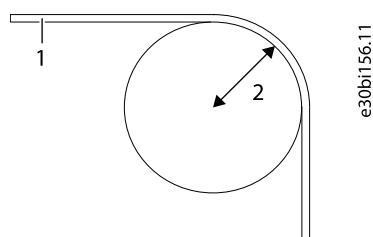

e30bt156.11

Figure 6: Bending Radius of the Fiber Cables

1	Cable	2	Bending radius (25 mm, 1.0 in)
---	-------	---	--------------------------------

5.7 Terminal and Connector Specifications

The Voltage Measurement Option OC7V0 has 2 voltage measurement groups with 2 channels each. The channels share a common reference pin.

NOTICE

Only 1 Voltage Measurement Option OC7V0 can be connected to 1 option extender.

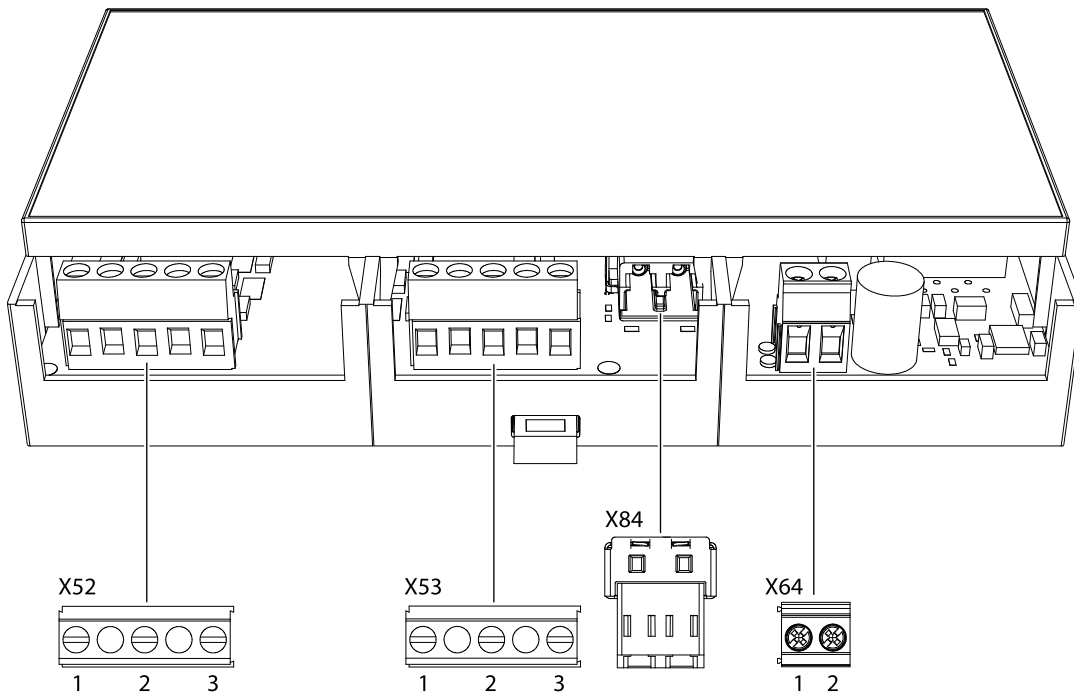

e30bk730.10

Figure 7: Terminal Locations on the Voltage Measurement Option OC7V0

Table 3: Connector Types for Voltage Measurement Option OC7V0

Terminal	Description
X52, X53 (TE CONNECTIVITY type 282843-3)	Screw connectors on PCB, not pluggable
X64 (TE CONNECTIVITY type 282841-2 or PHOENIX CONTACT type 1888687)	
X84 (Firecomms Ltd type FB2M5LVR(-P))	Plug-in type for the fiber optic cable

Table 4: Terminal Pin Assignments of Voltage Measurement Option OC7V0

Logical terminal	Terminal	Signal	Technical information
X52 voltage input 1 terminal			
1	1	L1 or DC1+	-
2	2	L2 or DC-	-
3	3	L3 or DC2+	-
X53 voltage input 2 terminal			
1	1	L1 or DC1+	-
2	2	L2 or DC-	-
3	3	L3 or DC2+	-
X64 supply voltage input terminal			
1	1	+24 V	24 V DC supply voltage from option extender only
2	2	GND	Reference for pin 1
X84 optic fiber connection			
No pins		Optic	Maximum optic fiber length 20 m (65 ft)

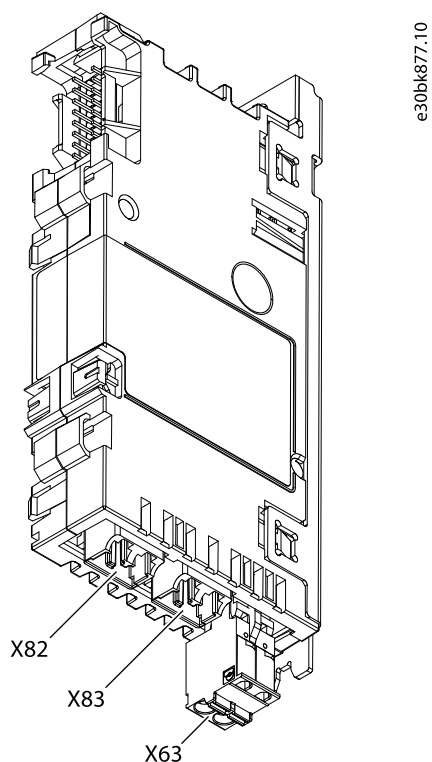

Figure 8: Terminal Locations on Option Extender OC7F2

Table 5: Connector Types for Option Extender OC7F2

Terminal	Description
X63 (Phoenix contact 1177657)	Plug-in type
X82 (Firecomms Ltd type FB2M5LVR(-P))	Plug-in type for the fiber optic cable
X83 (Firecomms Ltd type FB2M5LVR(-P))	

Table 6: Terminal Pin Assignments of Option Extender OC7F2

Logical terminal	Terminal	Signal	Technical information
X63 supply voltage input terminal			
61	1	+24 V	+24 V DC output
62	2	GND	Reference for pin 1
X82 optic fiber connection 1			
No pins		Optic	Maximum optic fiber length 20 m (65 ft)
X83 optic fiber connection 1			
No pins		Optic	Maximum optic fiber length 20 m (65 ft)

5.8 Installation Example Diagrams

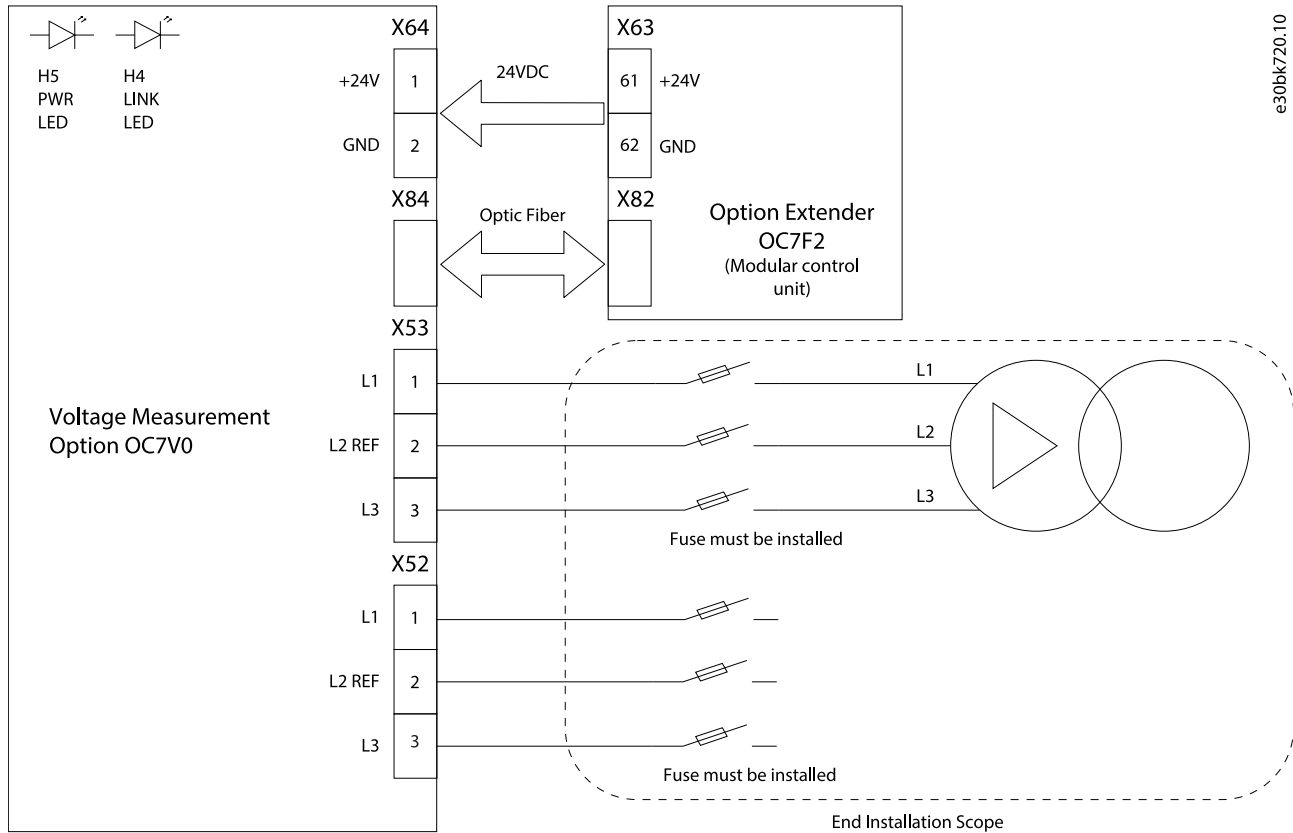
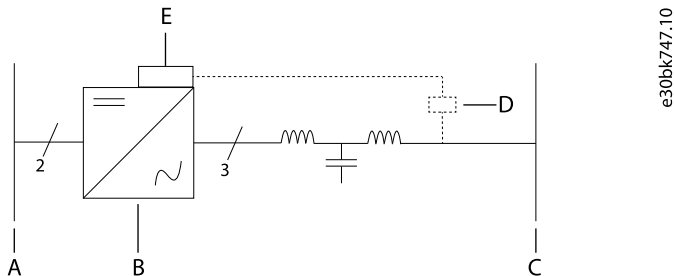

Figure 9: Delta Voltage Measurement

6 Application Examples

6.1 Grid Converter Control

The grid converter consists of a 3-phase inverter, a control unit, and an LCL filter.



e30bk747.10

Figure 10: Grid Converter with LCL Filter

A	DC bus	B	Inverter
C	AC Grid	D	Voltage Measurement Option OC7V0
E	Control unit		

The LCL filter can be replaced with an LC filter and a dedicated transformer as shown in [Figure 11](#).

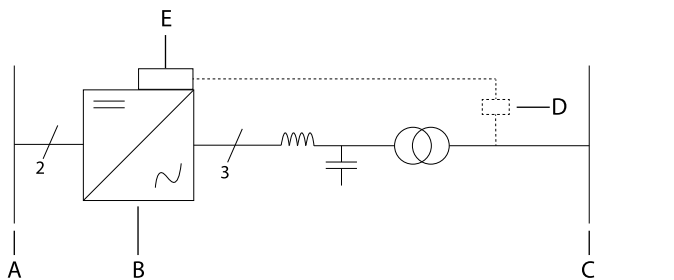

e30bk748.10

Figure 11: Grid Converter with LC Filter and Transformer

A	DC bus	B	Inverter
C	AC Grid	D	Voltage Measurement Option OC7V0
E	Control unit		

6.2 Line Filter Energization and Transformer Magnetization

The grid converter can charge the filter capacitors, magnetize the transformers, and synchronize the voltage measured from the grid side of the main circuit breaker. Thus the inrush currents and voltage transients occurring after the breaker closure are effectively avoided by using the Voltage Measurement Option OC7V0.

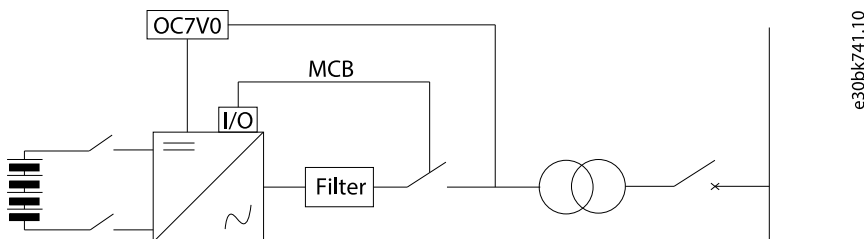

e30bk741.10

Figure 12: Line Filter Energization and Transformer Magnetization

6.3 Closed-loop AC Voltage Control

The grid converter control can be connected to different network nodes by using the Voltage Measurement Option OC7V0. For example, the voltage can be measured upstream of the line filter or the main transformer. The measurement location is configured in the application using the user parameter. An auxiliary voltage measurement transformer is used to step down the voltage to the input range of the Voltage Measurement Option OC7V0. Thus the measurement can be taken from medium voltage. The voltage loss across the transformer impedance is compensated using the closed-loop control when the measurement is from the load side. Open-loop transformer voltage drop compensation is available when the feedback is from the converter side.

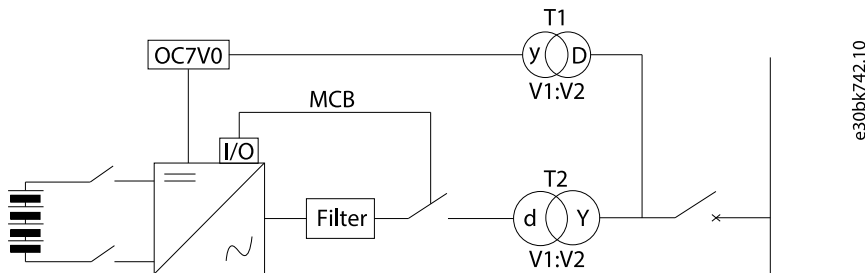

Figure 13: Closed-loop AC Voltage Control

6.4 External Grid Synchronization

The grid converter can supply an island microgrid and the Voltage Measurement Option OC7V0 can measure the external grid voltage on the other side of the tie breaker. With the help of the measurement, the grid converter can synchronize the islanded system voltage with the external grid before the tie breaker is closed. Thus the current transients involved in the breaker closure are minimized. In addition, there is no need for auxiliary synchronizer equipment. If there are transformers between the 2 circuit nodes, configure the phase difference of the converter voltage at the external grid measurement point.

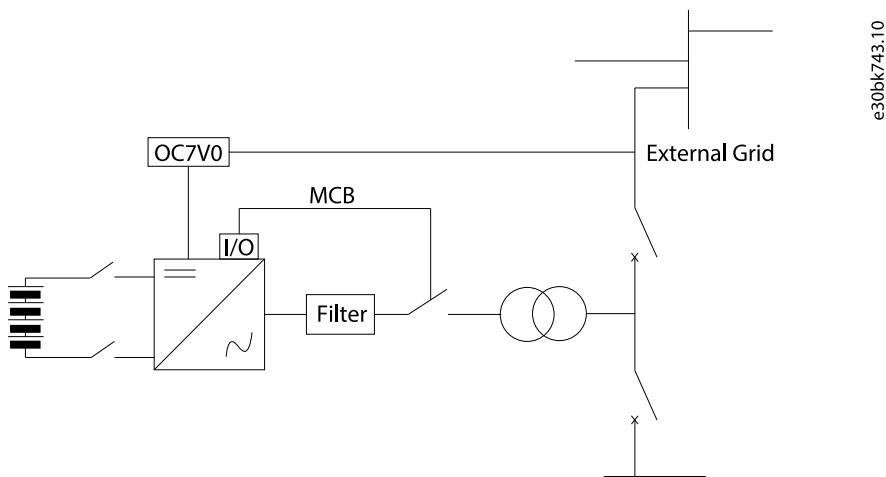

Figure 14: External Grid Synchronization

7 Specifications

7.1 Technical Data

Table 7: Voltage Measurement Option OC7V0 Specifications

Functions	Data	
Supply voltage (only 1 voltage measurement option for 1 option extender)		
Input voltage (supplied by option extender)	+24 V DC \pm 10% recommended twisted shielded pair for wiring	
Input current	Maximum 2 A, nominal 0.14 A	
Measurement channels		
Number of channels	Total 4, in 2 groups	
Measurement range, AC	0–759 V	
Measurement range, DC	-1354...+1354 V	
Absolute maximum, peak DC	-1689 V or +1689 V	
Measurement bandwidth	DC–20 kHz	
Measurement accuracy	\pm 0.5% of nominal	
Cable properties		
Cable type	Cu, 75 °C (167 °F)	
X64	Flexible/rigid wire without cable end sleeves	0.2–2.5 mm ² (24–14 AWG)
	Flexible wire with cable end sleeves with collar	0.25–2.5 mm ² (24–14 AWG)
	Stripping length	6.5 mm (0.26 in)
X52, X53	Solid/stranded wire	0.05–3.0 mm ² (30–12 AWG)
	Stripping length	6.5 mm (0.26 in)
X63	Rigid wire without cable end sleeves	0.2–1.5 mm ² (24–16 AWG)
	Flexible wire without cable end sleeves	0.2–2.5 mm ² (24–16 AWG)
	Flexible wire with cable end sleeves with collar	0.25–1.5 mm ² (24–16 AWG)
	Stripping length	10 mm (0.39 in)
Potential isolation		
Per module	Between input groups and supply voltage input	
Between the channels (input)	Reinforced insulation, OVC III, PD2	
Voltage supply for the module	24 V wired externally from the option extender	
Altitude		
Maximum altitude	3000 m (10800 ft)	
Maximum altitude, up to 480 V supply networks, no corner grounding	4000 m (13100 ft)	

Table 7: Voltage Measurement Option OC7V0 Specifications - (continued)

Functions	Data
Environment	
Overvoltage category	Category III
Pollution degree	PD2
Protection rating	IP00/UL Open Type
Ambient temperature (operating: normal conditions)	0...+75 °C (32–167 °F)
Ambient temperature (operating: reduced operation, reduced lifetime)	-40...+85 °C (-40...+185 °F)
Ambient temperature (transportation/storage)	-40...+70 °C (-40...+158 °F)
Ambient temperature (assembly)	0...+70 °C (32–158 °F)
Humidity	5–95% RH (no condensation allowed over the operating temperature range)
Weight	0.202 kg (0.445 lb)

7.2 Dimensions

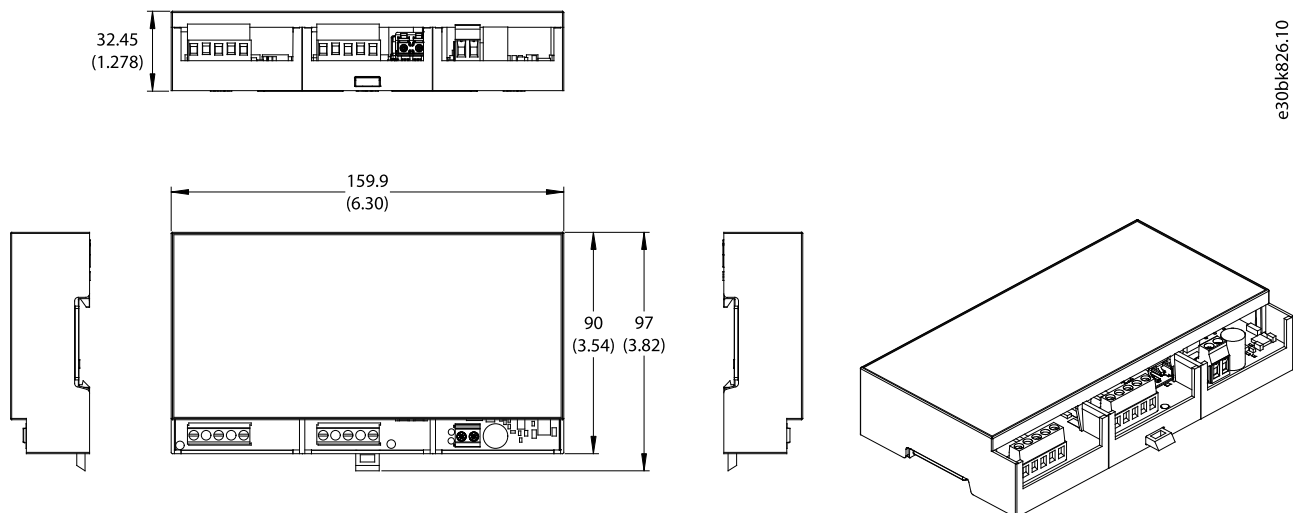

Figure 15: Dimensions of Voltage Measurement Option OC7V0

7.3 Related Standards

- IEC/EN 61800-5-1 Adjustable speed electrical power drive system – Part 5-1: Safety requirements – Electrical, thermal and energy
- IEC/EN 62477-1 Safety requirements for power electronic converter systems and equipment Part 1: General
- IEC/EN 61800-3 Adjustable speed electrical power drive systems – Part 3: EMC requirements and specific test methods for PDS and machine tools
- IEC/EN 61000-6-2 Electromagnetic compatibility (EMC) – Part 6-2: Generic standards – Immunity standard for industrial environments
- IEC/EN 61000-6-4 Electromagnetic compatibility (EMC) – Part 6-4: Generic standards – Emission standard for industrial environments
- CISPR 11 Industrial, scientific and medical equipment - Radio-frequency disturbance characteristics - Limits and methods of measurement



Danfoss A/S
Ulsnaes 1
DK-6300 Graasten
drives.danfoss.com

Any information, including, but not limited to information on selection of product, its application or use, product design, weight, dimensions, capacity or any other technical data in product manuals, catalog descriptions, advertisements, etc. and whether made available in writing, orally, electronically, online or via download, shall be considered informative, and is only binding if and to the extent, explicit reference is made in a quotation or order confirmation. Danfoss cannot accept any responsibility for possible errors in catalogs, brochures, videos and other material. Danfoss reserves the right to alter its products without notice. This also applies to products ordered but not delivered provided that such alterations can be made without changes to form, fit or function of the product. All trademarks in this material are property of Danfoss A/S or Danfoss group companies. Danfoss and the Danfoss logo are trademarks of Danfoss A/S. All rights reserved.

M00419
AQ476649821259en-010201
Danfoss A/S © 2026.06



1 3 6 R 0 3 3 2