

## IMPORTANT!

DO NOT CROSS OR CUT THE HEATING CABLE.  
REMEMBER TO MEASURE, VERIFY AND  
RECORD THE RESISTANCE. USE A MEGGER TO  
TEST THE RESISTANCE TO GROUND.

*Danfoss*



## Installation Manual

### Danfoss TX-FH Heating Cables

Danfoss *TX-FH*™  
BRINGING WARMTH TO LIFE





## **Table of Contents**

---

Danfoss TX-FH Electric Floor Heating System .....	2
Danfoss TX-FH Cable Specifications .....	3
Measuring the Resistance .....	3
General Notes.....	4
General TX-FH Cable Installation Guidelines.....	6
Danfoss TX-FH Installation - Step by Step.....	7
Danfoss Warranty .....	9
Appendix A: Layout Example .....	10



## Danfoss TX-FH Electric Floor Heating System

### Danfoss TX-FH Electric Floor Heating System

Danfoss TX-FH cables are a thick floor heating solution. Thick cables have a larger diameter than the Danfoss LX floor heating cables, allowing them to be lower in COST, higher in HEAT OUTPUT, and more DURABLE. They are installed in mud beds below the flooring materials and are most often used in new construction where overall material cost is a primary concern.

Benefits of the TX-FH thermal storage are numerous over other heating methods, and include:

- Easy and flexible installation combined with a single point connection.
- Extremely durable
- Single point connection
- Twin conductor cable
- Emits zero EMF (Electromagnetic fields)
- Safety approved for wet locations
- Reduced dust and allergens
- Silent, safe, and efficient operation
- Reclaimed interior floor space (no furnace/boiler required)
- Genuine ten year non-prorated warranty

### **CAUTION!**

It is important that this equipment is installed only by qualified electricians who are familiar with the proper sizing, installation, construction and operation of floor warming system and the hazards involved. The heating cable is designed for under floor heating purposes only.



## Danfoss TX-FH Specifications

<b>Type:</b>	Twin conductor
<b>Voltage:</b>	240V
<b>Output:</b>	6 W/ft (20 W/m)
<b>Heating Element Size:</b>	60 ft (18 m) to 680 ft (207 m)
<b>Power Lead</b>	10 ft (3.0 m)
<b>Cable Diameter:</b>	1/4 in ( 6 mm )
<b>Wire insulation:</b>	FEP, Teflon™
<b>Outer insulation:</b>	PVC
<b>Max. Allowable Temp.:</b>	220°F (105°C)
<b>Min. Installation Temp.:</b>	40°F (5°C)

Note : TX-FH cables operated on a 208V power supply will experience a 25% power reduction.

### Connection 240V

Phase - Black  
Phase - White  
Ground - Green

## Measuring the resistance

**WARNING:**  
**Remember to measure resistance.**



**MONITOR YOUR INSTALLATION!  
USE THE LITTLE BUZZER CONTINUITY  
ALARM (PART#088L0028)**



Using a digital Ohmmeter, the resistance should be measured between the black and white conductors. Compare the measured resistance to the resistance listed on the product label (on the power lead).

Also, measure the resistance between the black and green (ground) wires, and between the white and green (ground) wires to test the insulation resistance. Both should have infinite resistance. If available, Danfoss recommends using a megaohmmeter for this test with a voltage setting of up to 2500V.

Record the resistance on your warranty card. Documenting the resistance at each stage of the installation is required for warranty purposes. If the resistances do not match the expected values, the cable may need to be damaged and need repair. Contact your Danfoss representative for a repair kit (part # 088L0010)

While not required, you may also want to measure the resistance of the floor sensor. It should be approximately 12kΩ at room temperature.



## GENERAL NOTES

### Read before beginning installation!

- The installation shall be in accordance with the manufacturer's instructions and national and local electrical codes. The installation shall be in accordance with Part 424, American National Standard Institute / National Fire Protection Association (ANSI/NFPA70), National Electrical Code (NEC) and Canadian Electrical Code (CEC). Danfoss recommends GFCI for heating cables in normally wet areas ( i.e. bathrooms, showers, kitchens).
- All local codes concerning buildings, electrical installations etc. must be adhered to regardless of instructions provided in this manual. If these regulations are in direct conflict with instructions stated herein, please contact the Danfoss Electrical Heating Division.
- It is important that this equipment is only installed by qualified electricians who are familiar with the proper sizing, installation, construction and operation of electric heating cable systems and the hazards involved.
- Remember to check that the supply voltage matches the voltage required for your particular Danfoss TX-FH product;
- Extreme care must be used to ensure the TX-FH cables are not damaged when using sharp tools or other implements. Avoid walking on the cables or mats during installation;
- **Never cut the heating cable;**
- **Do not install the Danfoss TX-FH cables in such a manner that two heating cables touch, cross or overlap;**



## GENERAL NOTES ( continued )

### Read before beginning installation!

- Measure, verify and record the actual resistance throughout the installation process:
  1. Out of the box
  2. After installation
  3. After laying the mud bed
  4. After connecting thermostat and/or contactors

Record these values in the warranty card. Failure to do so will void the warranty;

- The Danfoss TX-FH electric heating system is most effective with tiled or stone or concrete floors. If carpet, wood or other flooring materials are to be used, please consult with Danfoss Electrical Heating Division.
- The TX-FH cable must be embedded in mortar or mortar mixture, concrete or similar material.
- Ensure that all sharp stones and debris are removed from the area where the heating cables are going to be installed.
- Make sure the cable is not subjected to excessive tension or strain, especially at the heating cable to power lead splice.
- At low temperatures, the heating cable stiffens and may be difficult to work with. To overcome this, connect the cable to the mains for a brief period of time. Ensure the cable is fully rolled out when this is done.
- Do not install TX-FH cable in walls or ceilings
- Do not install the heating cables under cabinets, kitchen island etc.
- Never use the heating cables to cure the tile adhesive products.
- Please consult the Danfoss Electrical Heating Division for any other questions, concerns or advice.

## General TX-FH Cable Installation Guidelines



### Cable Strapping

Should the Danfoss cable strapping ( part # 088L1051, # 088L1050 ) be used for the TX-FH cable, follow the instructions below for ease of installation.

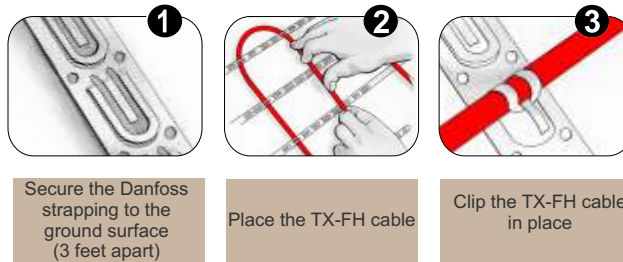

### Installing the heating cable

The TX-FH cable must be laid out with even spacing over the entire area to be heated. To ensure an accurate and easy method of installing the TX-FH cable it is recommended to use Danfoss cable strapping. The strapping should be laid perpendicular to the direction the cable will be unrolled. Space the strapping 3ft (90cm) apart. Secure the heating cable to the cable strapping at the correct center-to-center distance. Do not secure the cable too tightly as this may damage the cable.

If wire mesh is available, the cable strapping is not required. The heating cable can be attached directly to the rebar or wire mesh using tie wraps.

The heating cable can be also secured with hot melt glue, duct tape or 3/8" crown staples.



### Danfoss TX-FH Typical Installations

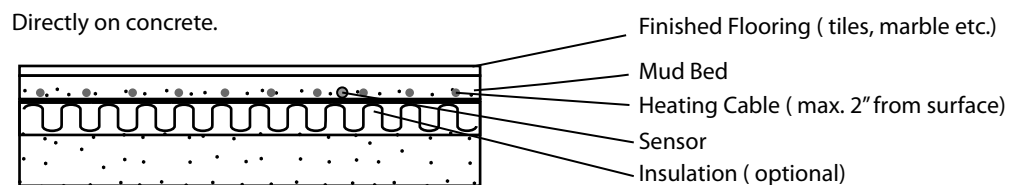
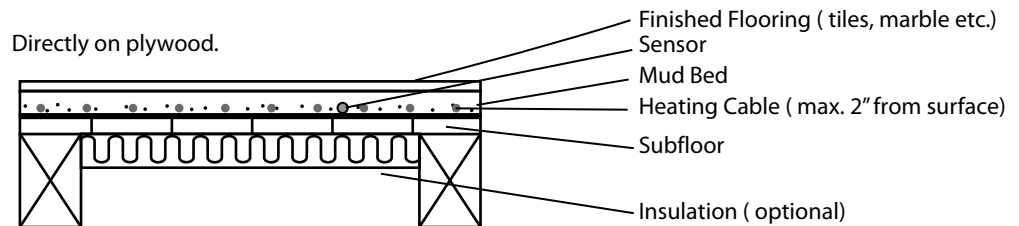



## Danfoss TX-FH Installation - Step by Step

### STEP 1: PLAN YOUR LAYOUT

Make a sketch of the area to be covered with heating TX-FH cables. Accurately measure the net area of the floor. This is the area you would walk upon. Do not install heating cable under the permanent fixtures. Select the cable spacing. Never space cables closer than 4" apart. Danfoss recommends 6" standard spacing.

You should also plan the location of the thermostats, floor sensors locations and their conduit's location. The start of cables should be as close as possible to the thermostat's final placement.

### STEP 2: INSTALLING THE FLOOR SENSOR AND CONDUIT

A floor sensor should be installed in a rigid conduit. The conduit protects sensor and facilitates its replacement in the unlikely event of failure.

The sensor and the conduit may be installed in connection with the actual construction work and connected at a later date. Please observe the following:

1. Ensure that the conduit is sealed before the concrete is poured.
2. The conduit must be positioned between the heating cables.
3. Place the sensor inside the tube until it reaches the end of the conduit.
4. The floor sensor should be installed at least 10 to 15 in into the heated area.
5. The floor sensor has a standard 10ft (3m) lead that may be extended with 20 AWG wire.

### STEP 3: MEASURE THE RESISTANCE OF THE HEATING CABLE

Using a digital ohm-meter, measure the resistance of the TX-FH cable. Compare the measured value with the resistance listed on the label of the power lead.

**Remember to record the measured resistances on the warranty card. Documenting the resistance at each stage of the installation is required for warranty purposes.**

### STEP 4: INSTALLING THE TX-FH CABLE

Install the heating cable. You may need to install the cable strapping before installing the TX-FH cable.

The power lead splice and at least 12in (30 cm) of the power lead must be embedded in the mass material. The remainder of the power lead should be in a conduit that extends to the thermostat or contactor. The power lead may be extended if required.

Measure the resistance once again and record the information on the warranty card.

TIP: Danfoss recommends taking a picture of the cable layout and conduit placement during installation. This can help in the unlikely case that the cables need repairs and for warranty claims.





## Danfoss TX-FH Installation (Continued)

### STEP 5: INSTALL THE FLOOR COVERINGS

Apply the mortar bed . Ensure that the contractors are careful not to damage the cable with tools, heavy bucket of cement , etc. When you are done installing the tile measure the resistance and record the information on the warranty card.

It is not recommended to power the cables for until the tile adhesive has cured (approximately 30 days). Check with the tile adhesive manufacturer for exact curing times. Doing so can affect both the integrity of the tiles, and the subsequent proper operation of the TX-FH cables.

### STEP 6: CONNECT POWER SUPPLY AND THERMOSTAT

The connection of the TX-FH thermostat must be done by a qualified electrician familiar with heating cables and in accordance with the National Electrical Code (NEC) and the Canadian Electrical Code (CEC). Remember to properly ground the heating cable braid.

If this is not already done, the sensor should be installed in the conduit. Remember that the sensor should reach the sealed end of the conduit. Connect the thermostat and sensor according to the wiring diagram in appendix A.

A final resistance reading of the cables should be carried out and the measured values recorded on the warranty card.

### STEP 7: RECORD INFORMATION AND AFFIX LABELS

- Ensure that all resistances measured are recorded on the warranty card.
- The eight digit product code found on the TX-FH cable power lead must be recorded on the warranty certificate.
- Install the electrical panel label at the electrical panel, indicating the location of the cable.
- Install the Warning label in a visible area of the floor, for the duration of the construction. It is also recommended that the label be kept in a suitable location on a permanent basis.

### STEP 8: ENJOY THE COMFORT OF DANFOSS TX-FH

The TX-FH electric heating system is now ready to use. Increase the temperature gradually and adjust it until it reaches a level that suits your personal preferences.



## EXTENDED WARRANTY

For a period of ten (10) years from the date of purchase Danfoss warrants that the Danfoss TX-FH cable is free from defects in material, design and workmanship. The extended warranty is only valid if the warranty certificate has been properly completed and mailed, and the installation is in accordance with the installation instructions.

The defective Danfoss TX-FH cable has to be inspected by or submitted to Danfoss or an authorized Danfoss TX-FH dealer. Failure to comply with all of the foregoing will void this extended warranty. Danfoss will, when the customer has documented that a defect in the Danfoss TX-FH cable was present at the date of delivery, repair or supply a new Danfoss TX-FH cable at Danfoss' option. All claims shall be made within the extended warranty period. Danfoss shall not be liable for any claims made later than ten years from date of purchase.

Danfoss shall not be liable for any consequential and secondary costs or damages linked to the defect or replacement of the Danfoss TX-FH cable. Danfoss will be liable for any costs related to the dismantling of defective product and the installation of a new product; however such liability is limited to the amount of five (5) times the initial product costs for each damage/case.

---

THE FOREGOING WARRANTY IS EXPRESSLY IN LIEU OF ALL OTHER WARRANTIES, EXPRESS OR IMPLIED, ON THE PART OF DANFOSS. DANFOSS DISCLAIMS ANY WARRANTY, EXPRESS OR IMPLIED, OF MERCHANTABILITY OR FITNESS FOR A PARTICULAR PURPOSE. DANFOSS NEITHER ASSUMES NOR AUTHORIZES ANY OTHER PERSON, FIRM OR CORPORATION TO ASSUME FOR IT ANY OTHER LIABILITY IN CONNECTION WITH SALE OR PRODUCT. DANFOSS SHALL NOT BE HELD RESPONSIBLE FOR DAMAGE TO PERSON OR PROPERTY, CONSEQUENTIAL LOSS, LOSS OF PROFIT, LOSSES ON GOODS IN STORE, OR THE LIKE WHICH MIGHT ARISE OUT OF THE FAILURE OF THE EQUIPMENT DELIVERED, IRRESPECTIVE OF THE CAUSE (INCLUDING FAULTY MANUFACTURE).

### How to claim this warranty

Contact the company's Customer Service department and provide the following information:

- 1) Nature of the manufacturing defect
- 2) Date of purchase and, if already installed, date of installation
- 3) If installed, name of electrician and foundation installer
- 4) Resistance readings taken by installer
- 5) Proof of purchase and serial number from product label

Our Customer Service department will provide you with an authorization number and advise you on the next steps to complete your warranty claim.

#### Disclaimer:

This warranty gives you specific legal rights and you may also have some legal rights which may vary from state to state or province to province. Danfoss hereby disclaims, and it is as a condition of the sale, that there are no implied warranties. Some states and provinces do not allow limitations on an implied warranty so the above limitation may not apply to you.

#### Manufacturer:

Mail: Danfoss Inc.  
6711 Mississauga Rd.,  
Suite 410  
Toronto, ON  
L5N 2W3  
Phone: 905-285-2050  
1-866-676-8062  
Fax: 905-285-2055

**APPENDIX A**

**LAYOUT EXAMPLE**

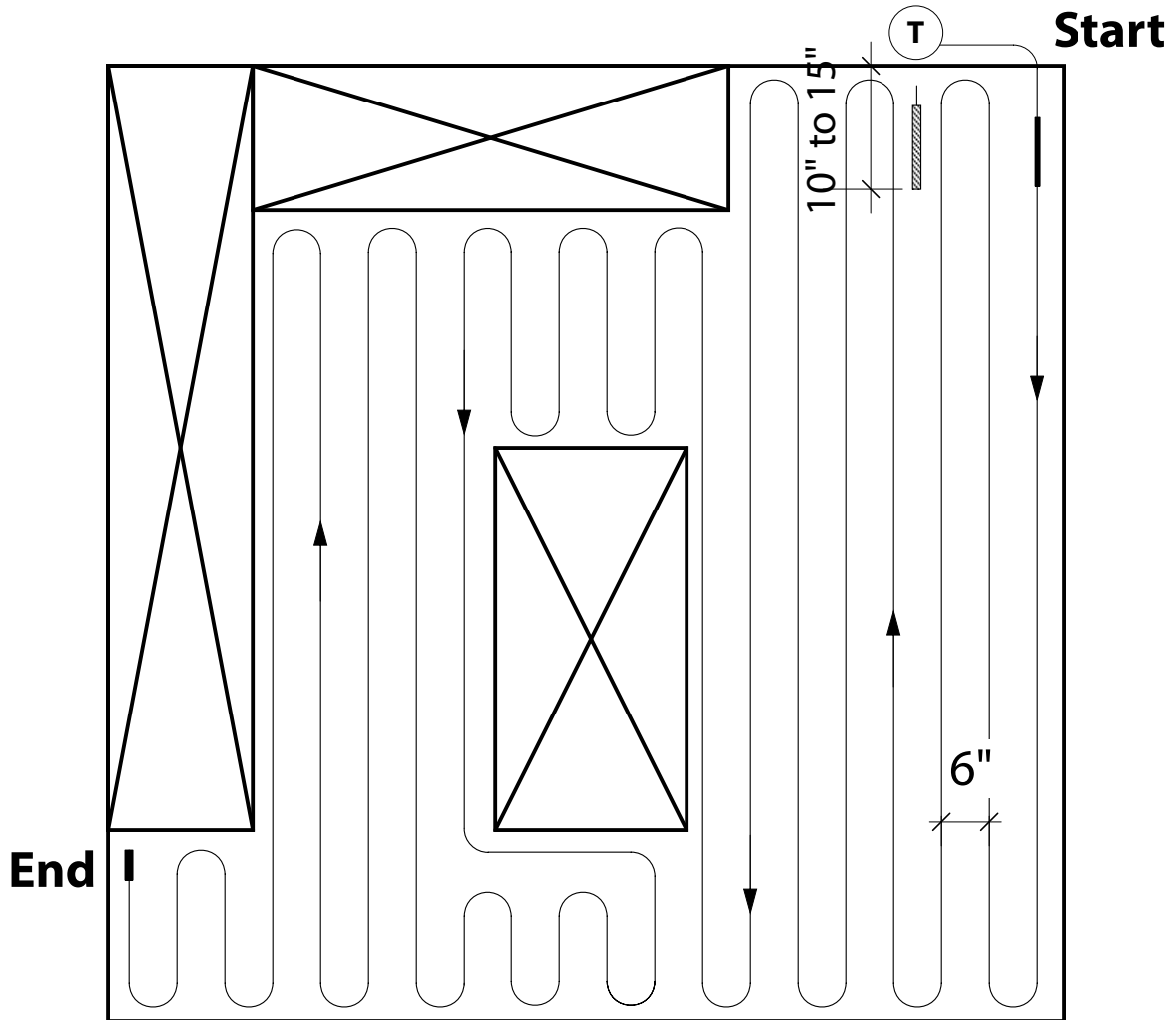

---

Danfoss can accept no responsibility for possible errors in catalogues, brochures, other printed materials, and website information. Danfoss reserves the right to alter its products without notice. This also applies to products already on order provided that such alteration can be made without subsequent changes being necessary in specifications already agreed upon. All trademarks in this material are property of the respective companies. Danfoss and the Danfoss logotype are registered trademarks of Danfoss A/S. All rights reserved.

---

The Danfoss logo is a stylized, cursive script of the word "Danfoss" in black, with a horizontal line underneath the letters.

Danfoss Inc.  
Toronto  
Toll Free: 866-676-8062  
Phone: 905-285-2050  
Fax: 905-285-2055  
[www.LX.Danfoss.com](http://www.LX.Danfoss.com)

**Danfoss TX**  
BRINGING WARMTH TO LIFE