

Instructions

ECL Comfort 210 / 296 / 310, communication description



Table of Contents

1. Introduction.....	3
2. ECL Comfort 210/296/310 communication interfaces.....	4
3. USB service port	5
3.1 USB driver installation.....	5
4. RS-485 Modbus.....	6
4.1 RS-485 network description.....	7
5. Modbus/TCP, Ethernet description	10
5.2 Static IP address	10
5.3 Dynamic IP address.....	11
5.4 Ethernet network example.....	11
6. ECL Comfort 210/296/310 Modbus description	13
6.1 Modbus address.....	13
6.2 RS-485 Baud rate.....	13
6.3 RS-485 Bias/polarization.....	14
6.4 Mode and status	14
6.5 Heat curve.....	15
6.6 Time and date.....	16
6.7 Rules for schedule adjustment.....	17
6.8 Anti-bacteria.....	18
6.9 Holiday.....	19
6.10 Alarm	20
6.11 Energy meter data, M-bus (from version 1.10).....	20
6.12 System information parameters	23
6.13 System commands.....	26
6.14 Output status, Manual output status and Output override	26
6.15 Configurable input.....	28
6.16 Unit and pulse.....	32
6.17 Limiter status (from version 1.32).....	32
7. Modbus protocol	33
7.1 Function codes.....	33
7.2 Broadcasts.....	35
7.3 Error codes.....	35
7.4 Modbus/TCP.....	35
7.5 Communication example.....	35
8. ECL 485 bus description	37
8.1 Installation of the ECL 485 network.....	37

9. Appendix	40
9.1 References.....	40
9.2 Definitions and Abbreviations.....	40
9.3 Energy meter type descriptions.....	41
9.4 Good behavior in designing a district heating Modbus network	43
9.5 Parameter list (PNU list)	45
9.6 Revision History.....	61

1. Introduction

This document describes the various communication possibilities built into the ECL Comfort 210, ECL Comfort 296 and ECL Comfort 310 product family.

The initial sections describe the main communication interfaces and their specific properties. The following describes Modbus specific implementations.

The last section describes the communication details of the ECL 485 master/slave bus.

For specific application details consult the application instructions, where the needed information about sensor and output assignments is available.

The application instructions are available here
<http://heating.danfoss.com>

For quick reference to some of the most typical used parameters in SCADA, see the section Parameter list (PNU list) in the Appendix.

ECL Comfort 210 / 296 / 310, communication description

2. ECL Comfort 210/296/310 communication interfaces

There are three communication interfaces for the ECL Comfort 210/296/310.

- USB service port, Modbus RTU with relaxed timing (non Modbus standard)
- RS-485 Modbus RTU, ECL Comfort 296 / 310 with galvanic isolation
- Modbus/TCP, Ethernet communication, ECL Comfort 296 / 310 only

Furthermore, there is an M-bus communication interface for heat meters and an ECL 485 bus for master/slave communication between ECL Comfort 210/296/310 products only.

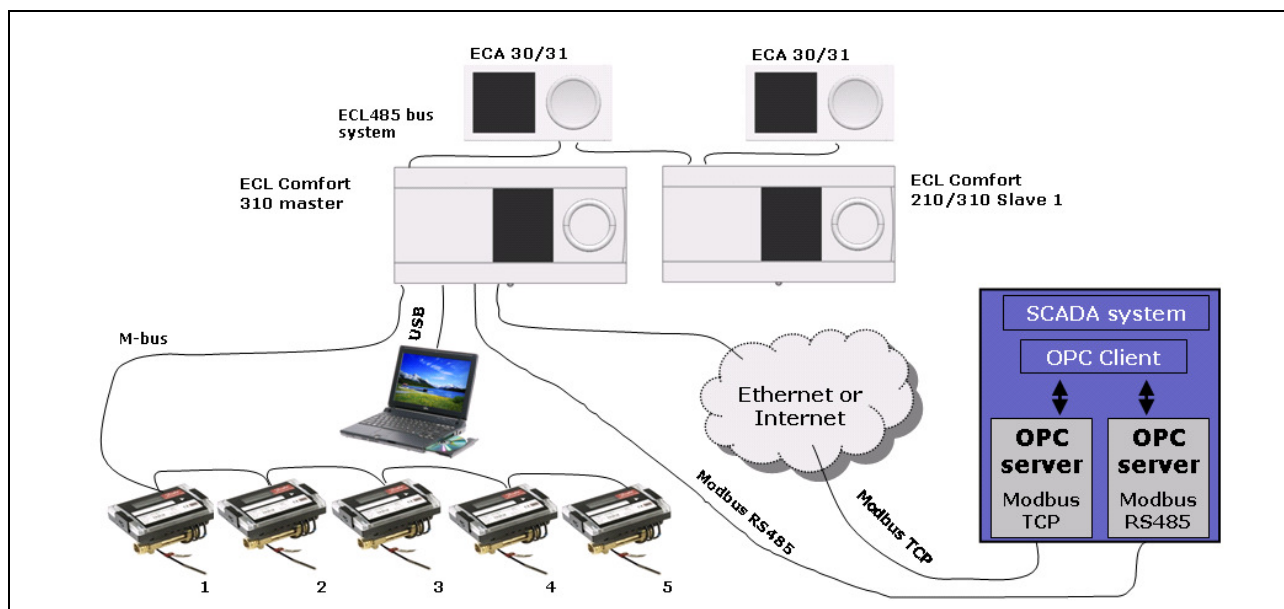

Figure 2-1:
Various communication interfaces for the ECL Comfort 210/296/310 products

The ECL Comfort 210/296/310 product family includes:

- ECL Comfort 210 controller
- ECL Comfort 296 controller
- ECL Comfort 310 controller
- ECA 30 room unit
- ECA 31 room unit with humidity sensor
- ECA 32 internal extension module



The ECL Comfort 210/296/310 product family is not compatible with older ECL controllers such as ECL Comfort 100/110, ECL Comfort 200/300 or ECA modules such as ECA 60-63, ECA 71/73, ECA 80-88.

3. USB service port

The USB service port enables easy on-site connectivity for the ECL Tool

The USB service port implements a Communication Device Class (CDC) that allows Windows PCs to recognize the ECL Comfort 210/296/310 as a Virtual Serial Port, giving functionality of a point-to-point Modbus RTU communication with the ECL.

The USB service port is similar to the RS-485 Modbus interface, with the following changes:

- Relaxed inter character timing in comparison to standard serial line Modbus
- Baud rate independent
- Point-to-point communication, only the connected ECL can be addressed (service address 254 can be used)

It is necessary to install the ECL USB driver on the PC before it is possible to communicate with the ECL controller via USB.

The driver is available as a free download from <http://heating.danfoss.com>

Information about the ECL Tool is available from <http://heating.danfoss.com>

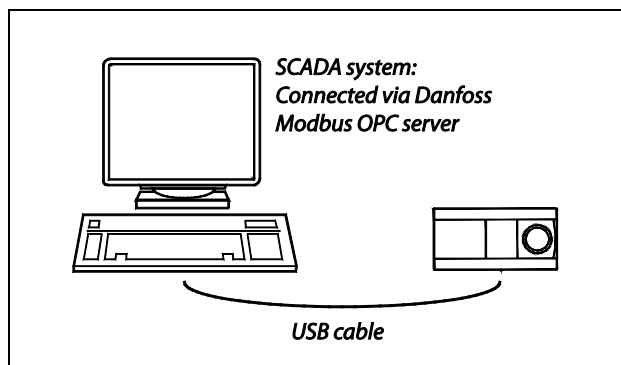

Figure3-1: USB connection example

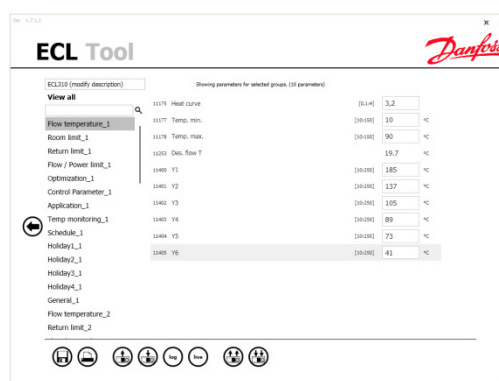

Figure3-2: ECL Tool example

3.1 USB driver installation

- Connect the ECL to the PC
- When Windows asks for a driver, choose the appropriate driver for your system (See the installation guide that accompanies the driver). On Win2k and WinXP systems, Windows will warn that the driver is not 'digitally signed'. Ignore this message and continue with the installation.
- Open the Windows Device Manager to verify that the device is installed correctly.
- A reboot is not necessary.

(see the in-depth installation description in the driver package)

4. RS-485 Modbus

The figure illustrates what a Modbus network might look like.

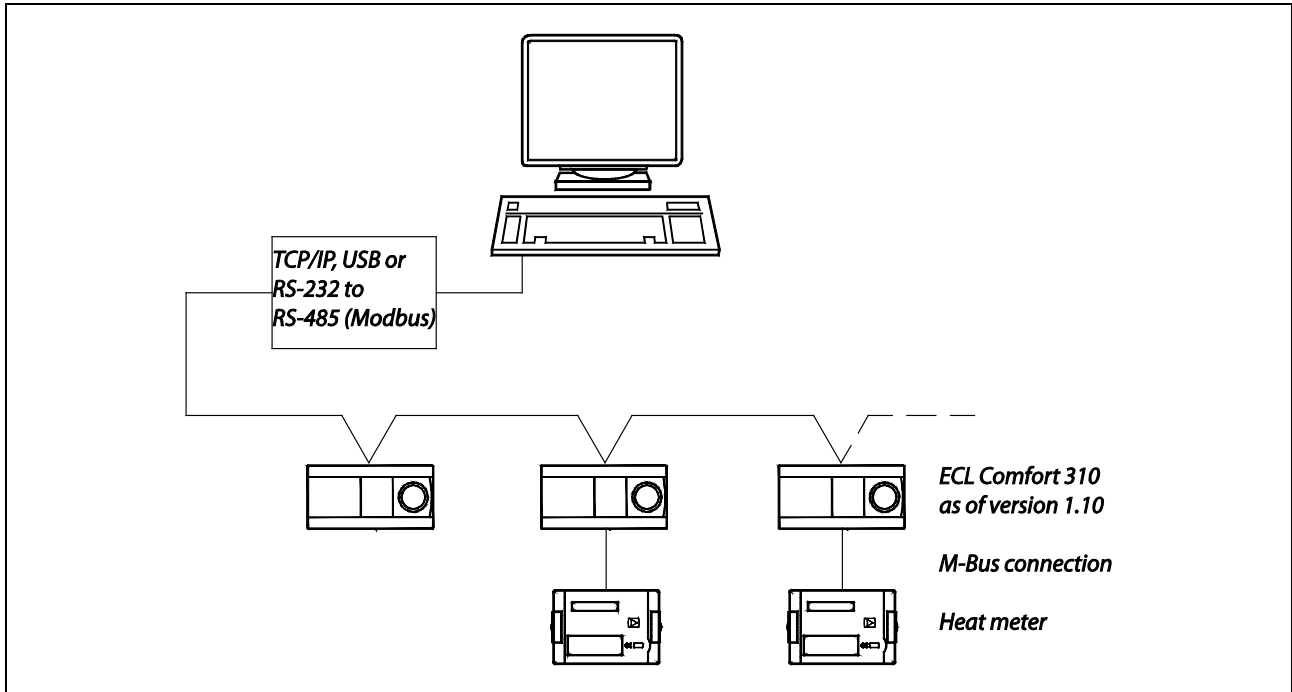

Figure 4.1: Modbus network overview

4.1 RS-485 network description

The network used for this module is conditionally compliant (implementation class = basic) with the Modbus over serial line two-wire RS-485 interface. The module uses the RTU transmission mode. Devices are connected directly to the network, i.e. daisy chained. The network uses line polarization and line termination at both ends.

These guidelines depend on the environmental conditions and the physical network characteristics:

- Maximum cable length of 1200 m without repeater
- 32 devices pr. master / repeater (a repeater counts as a device)

All devices in the network must use the same communication settings, i.e. multiple communication settings are not allowed. The module can operate with

- 9600, 19200 or 38400 (default) baud rate
- 1 start bit
- 8 data bits
- even parity
- 1 stop bit
(in total 11 bits).

For specific details, please consult the specifications

- Modbus Application Protocol V1.1a.
- Modbus over Serial Line, Specification & Implementation guide V1.0

both of which can be found on <http://www.Modbus.org/>

4.1.1 Network layouts

Figure 4-2 illustrates how termination and line polarization must be added. For specific details, consult the Modbus specifications.

ECL Comfort 210 / 296 / 310, communication description

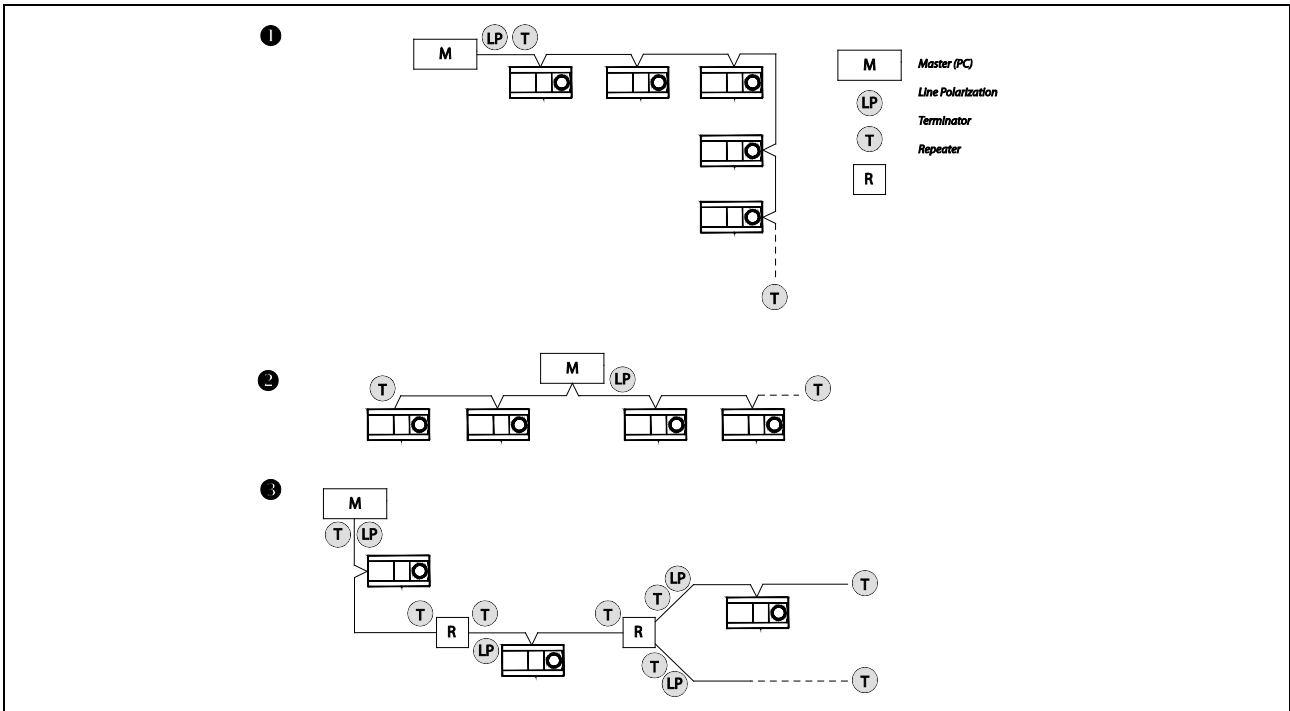

Figure 4-2: Three daisy chain network layouts

Figure 4-3 illustrates some network layouts that will not work properly.

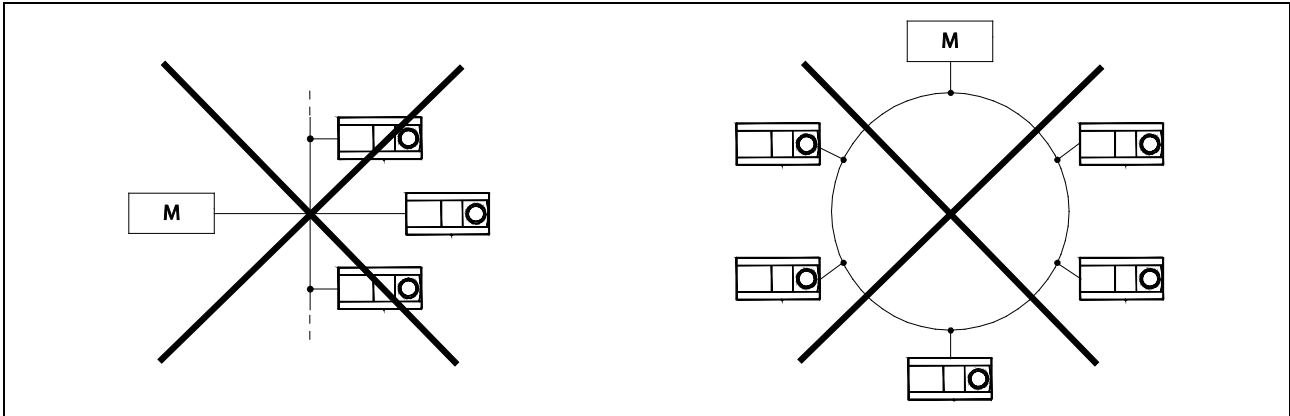

Figure 4-3: Examples of unusable network layouts

4.1.2 Installing a Modbus network

It is recommended that all of the devices on a network are installed sequentially to ensure that they will not conflict with each other.

If two or more devices have the same Modbus address they will conflict, resulting in loss of communication to that address!

The communication settings can be found in the ECL menu 'Common controller settings' > 'System' > 'Communication'

System	<input type="checkbox"/>
Communication:	
ECL 485 addr.	15
▶ Modbus addr.	1
Baud	38400
Service pin	0
Ext. reset	0

Figure 4-4: Communication settings example

5. Modbus/TCP, Ethernet description

The ECL Comfort 296 / 310 has a Modbus/TCP communication interface that allows the ECL to be connected to an Ethernet network. This allows remote access to the ECL Comfort 296 / 310 controller based on standard communication infrastructures.

For specific details, please consult the Modbus guide [Modbus_Messaging_Implementation_Guide_V1_0b.pdf](#)

which can be found on <http://www.Modbus.org/>

Specific implementation details:

The ECL Comfort 296 / 310 listens for communication on TCP port 502.

Opened Modbus/TCP connections are closed by the ECL Comfort 296 / 310 controller after approximately 75 seconds without any data exchange.

If multiple controllers are present on the same network, they must use different IP addresses.

If multiple controllers are present on a single Internet IP address, a router/firewall must perform port translation so that it is possible to distinguish the controllers by port number. See Figure 5-1 for an example.

Note that not all routers support this and some ISPs (Internet Service Providers) do not allow customers to reconfigure the routers.

Default IP address is 192.168.1.100

5.1.1 Recommended security measures

Place the ECL310 behind a router. Set rules in the firewall that limits the port forwarding range to the ECL to what is needed. If possible, limit the number of IP addresses that can communicate with the ECL310 to a few trusted addresses.

5.2 Static IP address

The ECL Comfort 296 / 310 uses a static IP address as default. DHCP is an option for software version 1.30 and higher. When installing multiple ECL Comfort 296 / 310s on an Ethernet network then be sure to give them unique IP addresses, as they will all have the same default IP address.

Remember also to change the gateway address, net mask and DNS addresses if needed.

The communication settings can be found in the ECL menu

'Common controller settings' > 'System' > 'Ethernet'



Security Note:

The Modbus/TCP implementation guide does not specify a specific security model.

The ECL Comfort 296 / 310 controller does not use any form for access control restriction and it is therefore strongly advised to only use it on a secure local network where a router/firewall provides security to other local networks or the internet. In most routers it is possible to set simple access restrictions for which kind of internet traffic that are allowed to reach the ECL Comfort 296 / 310.

Modbus/TCP communication is not affected by the removal of the key from the ECL controller. It is still possible to change all settings through communication even if the key has been removed in order to prevent this!



It is necessary to reset the controller when internet settings have been changed in order for the changes to take effect for software versions lower than 1.30.

It is recommended to only change Ethernet settings directly at the ECL or via the Modbus RS-485 or USB interface.

ECL Comfort 210 / 296 / 310, communication description

5.3 Dynamic IP address

If the ECL Comfort 296 / 310 is connected to a router that uses a dynamic Internet IP address, a Dynamic DNS (Domain Name System) service can be used to make the installation addressable from a URL name instead of an IP address. E.g. "my_ecl_installation.com" instead of "193.162.34.195".

Several companies provide dynamic DNS services. Searching the internet for dynamic DNS providers can result in these lists among others:

- <http://www.technopagan.org/dynamic/>
- http://www.dmoz.org/Computers/Internet/Protocols/DNS/DNS_Providers/Dynamic_DNS/

5.4 Ethernet network example

The following figure shows a more complex example of a possible network installation. The example also shows the ECL 485 installation for master/slave function.

The installation is separated into two different groupings, which could represent two different building blocks with a single centralized Internet router.

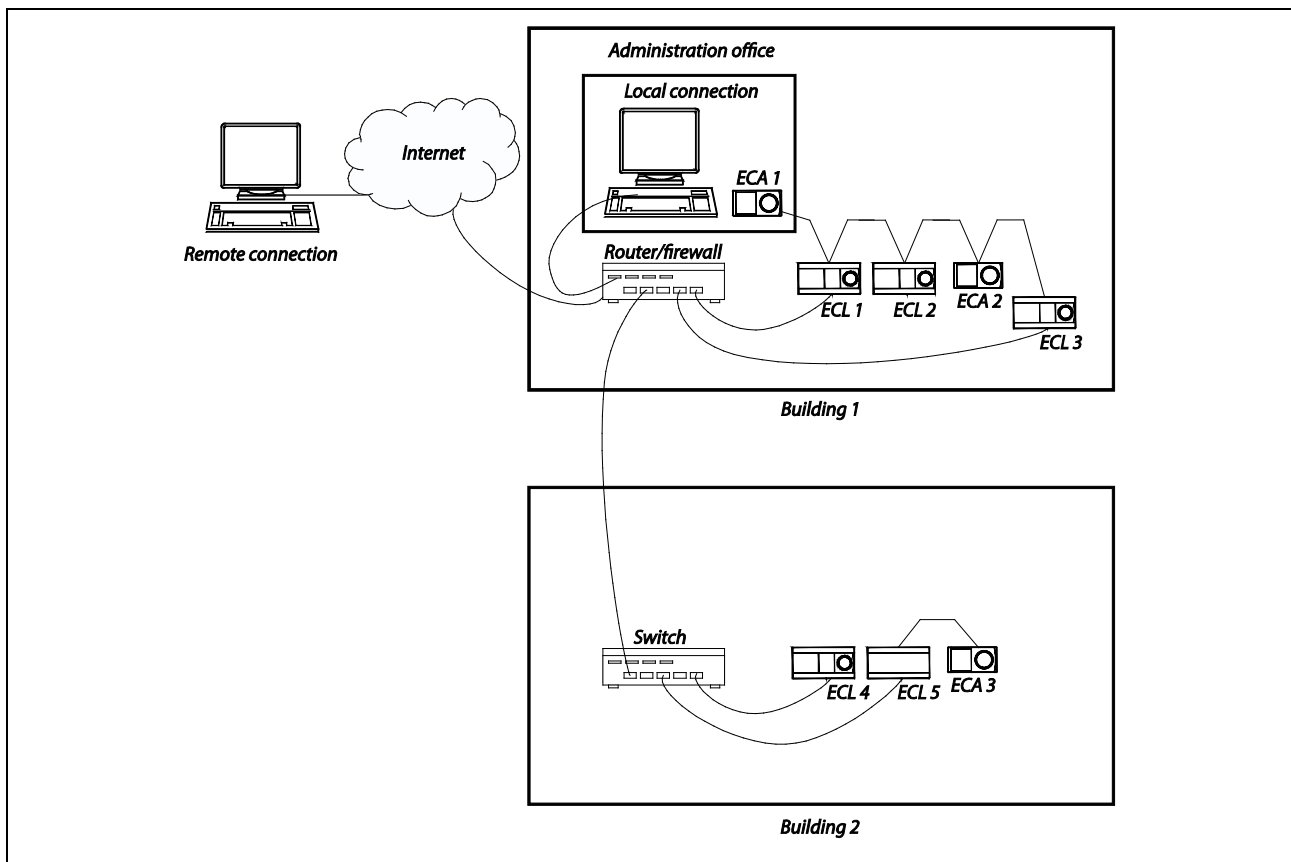

Figure 5-1: Example of an ECL 485 network where some of the controllers are connected to the internet

ECL Comfort 210 / 296 / 310, communication description

In order to contact the controllers on the local area network from the internet it is necessary for the router to perform a port translation.

Table 5-1 lists the addresses on the network. The "Local address" can be used inside the network (private). The "Remote address" must be used from internet side (public). The router/firewall must be setup to handle the necessary port translations.

Table 5-1: Router/firewall port translation example

Network	Device	Local address	Remote address	ECL 485 address
1	ECL 1	192.168.1.100 port 502	1.2.3.4 port 503	15
	ECL 2		--	1
1	ECL 3	192.168.1.102 port 502	1.2.3.4 port 504	2
	ECA 1 (HMI A)	--	--	A
	ECA 2 (HMI B)	--	--	B
2	ECL4	192.168.1.110 port 502	1.2.3.4 port 505	4
2	ECL 5	192.168.1.111 port 502	1.2.3.4 port 506	15
	ECA 3 (HMI A)	--	--	A

In the example, only the 4 ECL controllers that are connected to the router are accessible from the Internet.

Be sure to select ports that do not interfere with other services or firewalls running on the network or on the remote connection network from which the ECL is contacted.

See

www.en.wikipedia.org/wiki/List_of_TCP_and_UDP_port_numbers

for a list of standard port assignments.



Be careful when using port translation on a network where the ECL controllers are using DHCP for Ethernet configuration. DHCP is a dynamic protocol which sometimes can assign different local addresses which will interrupt the port translation.

6. ECL Comfort 210/296/310 Modbus description

This section describes the overall ECL Comfort 210/296/310 Modbus communication interface.

Parameter naming

The parameters are overall divided into two functional sections, the application – and system parameters.

Application parameters depend on the used application, e.g. “A266.1”, and include parameters such as temperature set-points, schedules and control properties etc. The parameters are as rule of thumb located in the address range 11000 – 13999. The 1000th decimal indicates the ECL Comfort circuit number, i.e. 11xxx is circuit 1, 12xxx is circuit 2, 13xxx is circuit 3. The number of applicable circuits depends on the Application, e.g. “A266.1” has 2 circuits (1 heating circuit and 1 DHW circuit).

System parameters include parameters such as system information, raw values, communication settings, output override, input configuration and time & date.

Some of the Parameter Numbers (PNU's) can be seen directly in the ECL display – the ID number.

The application parameters are named (numbered) in accordance with their name in the ECL Comfort.

A partial list of parameters can be found in the appendix.

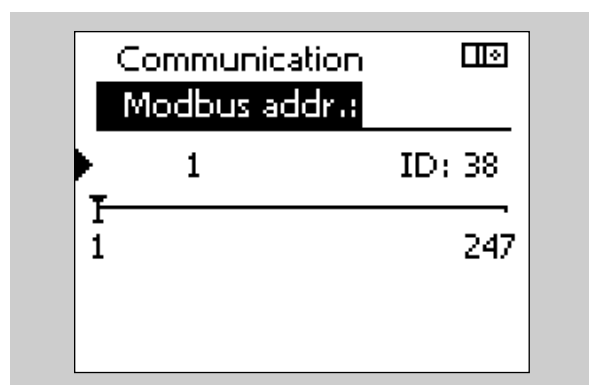
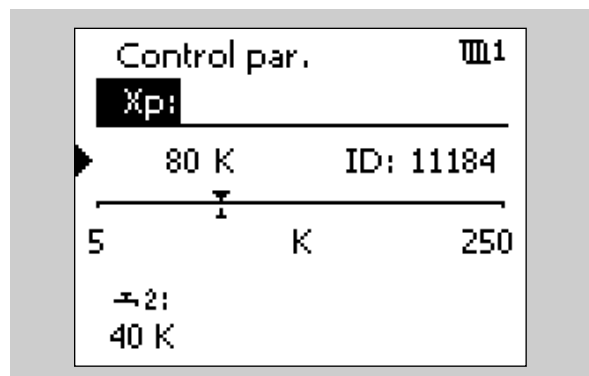

Figure 6-1: Display parameter number examples

6.1 Modbus address

The valid Modbus address range is 1 – 247. The default Modbus address is 1.

Address 254 is used as service address and may only be used when one ECL is connected, e.g. USB service port or Modbus/TCP.

The Modbus address can be changed by writing to PNU 38.

Modbus address changes take effect immediately.

It is recommended only to change the Modbus address directly at the ECL or via the Modbus USB interface.

6.2 RS-485 Baud rate

The baud rate for the RS-485 bus can be changed by writing 9 (for baud rate 9600), 19 (for baud rate 19200) or 38 (for baud rate 38400, this is default) to PNU 39 via Modbus. Attempts to write any other values are rejected.

All devices on a network must have the same baud rate.

The ECL menu for changing the baud rate was not included until ECL software version 1.30 so for previous versions it could only be changed through communication.

Baud rate changes take effect immediately.

Care must be taken if the baud rate is changed via the Modbus interface because the communication connection will be lost due to the change.

ECL Comfort 210 / 296 / 310, communication description

6.3 RS-485 Bias/polarization

Biasing/polarization on the RS-485 Modbus network is necessary for the bus to operate properly. It can be controlled by writing 0 (disable, this is default) / 1 (enable) to PNU 2049.

To simplify the installation, Danfoss recommends that bias/polarization is implemented at the Modbus master.

See the section 'Network layouts' for further information about biasing/polarization.

6.4 Mode and status

The mode parameters are located within the PNU range 4201 – 4206, i.e. 4201 is circuit 1, 4202 is circuit 2, ..., 4206 is circuit 6. The mode can be used to control the ECL Comfort mode.

The status parameters are located within the PNU range 4211 – 4216, i.e. 4211 is circuit 1, 4212 is circuit 2, ..., 4216 is circuit 6. The status indicates the current ECL Comfort status.

If one circuit is set to manual mode, it applies to all circuits (i.e. the controller is in manual mode). When the mode is changed from manual to another mode in one circuit, it also applies to all circuits in the controller. The controller automatically reverts to the previous mode for each circuit if the information is available.

All output will follow the ECL manual output setting when in manual mode.

The operating status will be read as 0 (setback) if the operating mode is larger than 3.

Operating status was enlarged from 4 states to 8 states in firmware version 1.43

Table 6-1:

Operating mode	Code
Manual operation	0
Scheduled operation	1
Constant comfort temperature	2
Constant setback temperature	3
Frost protection/standby*	4
Active cooling**	5









*

Standby and frost protection modes are not available in all applications. In general, the standby mode is available in cooling applications instead of frost protection. Please read the application instructions if in doubt.

**

Active cooling is only available in A232.

Table 6-2:

Operating status	Symbol	Code
Setback		0
Pre-comfort		1
Comfort		2
Pre-setback		3
Holiday constant comfort temperature		4
Holiday 7-23h comfort temperature		5
Holiday constant setback temperature		6
Holiday frost protection/standby		7

6.5 Heat curve

The heat curve has six points consisting of an outdoor temperature coordinate and a flow temperature coordinate. The outdoor temperature coordinates are not adjustable but the flow temperature coordinates can be changed to give a flow temperature that corresponds to the building's thermodynamic properties.

Table 6-3: Addresses for circuit 1 heat curve

Parameter	PNU	Default value
Slope (read only, scale = 10) ¹	11175	10 (= 1.0)
Min. flow temperature	11177	10 °C
Max. flow temperature	11178	90 °C
Flow temp at -30 °C	11400	75 °C
Flow temp at -15 °C	11401	60 °C
Flow temp at -5 °C	11402	50 °C
Flow temp at 0 °C	11403	45 °C
Flow temp at 5 °C	11404	40 °C
Flow temp at 15 °C	11405	28 °C

The minimum value for the parameters in Table 6-3 is 10 °C and the maximum value is 150 °C. It is possible to set the flow temperature higher than the maximum flow temperature setting (default 90 °C) but the flow temperature will still be capped by the maximum. The slope will possibly still be affected depending on the other flow temperature points.

Table 6-3 is for circuit 1 parameters. For circuit 2 add 1000 to the PNU. For circuit 3 add 2000 to the PNU and so on.

Not all applications or circuits have a heat curve.
If an Application has a writable Slope, e.g. 11175, writing this value will cause adjustment of the point values, e.g. 11400 – 11405.

¹ Not all applications allow readout of this parameter. Not all applications allow write of this parameter

6.6 Time and date

The time and date parameters are located in the PNU range 64045 – 64049.

Table 6-4:

Parameter	PNU
Hour [0;23]	64045
Minute [0;59]	64046
Day [1;31]	64047
Month [1;12]	64048
Year [2009;2099]	64049
Automatic summer time [0;1]	10198

6.6.1 Rules for setting time

The valid date range is from 01/01/2009 to 31/12/2099 using the Gregorian calendar.

When a new time is set, the seconds are internally reset to 0 in the controller. It is not possible to externally set seconds.

If an attempt is made to set an invalid time, it will be rejected.

When adjusting the date, it is necessary to set a valid date.

Example: If the date is 30/3 and it must be set to 28/2, it is necessary to change the day first before changing the month because 30/2 is not a valid date. Likewise, care must be taken during leap years. If the set date is 29/2/2012 then it is necessary to change the day before changing the year because 29/2/2011 is not a valid date.

Summer time rules

The rules for summer time change are the EU rules for central Europe. If the automatic summer time is enabled, the hour in which the clock is set forward is not a valid time. If the time is changed from 02:00 to 03:00, the time between 02:00 and 03:00 cannot be valid. Consequently, it is therefore not possible to change the time to e.g. 02:15 on the day where the summer time change takes place. By disabling automatic summer time, it is possible to overcome this problem but remember to enable it again!

When the clock is set back to normal time in autumn, the time between 02:00 and 03:00 will exist twice. The controller will therefore automatically assume that any time adjustment in that interval is after the changeover, i.e. that the summer time has ended.

Summer time starts on the last Sunday in March and ends on the last Sunday in October.

Automatic summer time is enabled by writing 1 to address 10198 and disabled by writing 0 to the same address.

6.7 Rules for schedule adjustment

The ECL Comfort divides the schedules into 7 days (1–7), each day consisting of 48 periods lasting 30 minutes.

1. The periods must be entered in chronological order, i.e. P1 ... P2 ... P3.
2. Start and stop values must be in the range 0, 30, 100, 130, 200, 230 ..., 2300, 2330, 2400.
3. Start values must be before stop values if the period is active.
4. When a stop period is written equal to the start period, the period is not active.
5. Written values that would cause invalid periods, will force automatic adjustment of affected periods

Table 6-5: Address range circuit 1

		Monday	Tuesday	Wednesday	Thursday	Friday	Saturday	Sunday
P1	Start 1	3110	3120	3130	3140	3150	3160	3170
	Stop 1	3111	3121	3131	3141	3151	3161	3171
P2	Start 2	3112	3122	3132	3142	3152	3162	3172
	Stop 2	3113	3123	3133	3143	3153	3163	3173
P3	Start 3	3114	3124	3134	3144	3154	3164	3174
	Stop 3	3115	3125	3135	3145	3155	3165	3175

ECL Comfort 210 / 296 / 310, communication description

As a general rule the address range for circuit 1 is 3110-3175, for circuit 2 it is 3210-3275, for circuit 3 it is 3310-3375 and for circuit 4 it is 3410-3475. However, some applications can have special schedules for relays controlling pumps or other things that need to run on a time schedule. Therefore, address ranges 3510-3575, 3610-3675, 3710-3775, 3810-3875 and 3910-3975 can also be used by some applications.

Example:

The schedule for Tuesday is P1 starts at 6:30 and stops at 08:00, P2 starts at 16:30 and ends 22:00 and P3 is not active.

- Write 630 to address 3120
- Write 800 to address 3121
- Write 1630 to address 3122
- Write 2200 to address 3123
- Write 2400 to address 3124
- Write 2400 to address 3125

A time period can be deactivated by writing 2400 as start and stop time.

If 0 is written as a stop value, then all other previous values on that day are also set to 0. Therefore 0 is recommended to only be used as a start value for P1.

6.8 Anti-bacteria

The anti-bacteria function can be set to be active on several days per week by setting the day setting to a value corresponding to a combination of the days. Table 6-6 shows how to calculate the value for days on which the function is active. The letter combination is for Sunday, Saturday, Friday, Thursday, Wednesday, Tuesday and Monday. Each day corresponds to a bit in the day setting so they can be combined together to give a binary value for the whole week. Table 6-6 shows some examples of how the days can be combined and gives the corresponding binary and decimal values. Table 6-7 gives the addresses for the anti-bacteria settings.

Table 6-6: Value examples for the day setting

Sun	Sat	Fri	Thu	Wed	Tue	Mon	Binary value	Decimal value
0	0	0	0	0	0	1	0000001	1
0	0	0	0	0	1	1	0000011	3
0	0	0	1	0	0	0	0001000	8
0	0	1	0	1	0	1	0010101	21
1	0	0	1	0	0	1	1001001	73
1	1	1	1	1	1	1	1111111	127

The start time value must be in the range 0-47 which corresponds to half-hour periods during the day like this: 0 = 00:00, 1 = 00:30, 2 = 01:00, 3 = 01:30 ... 47 = 23:30. The function will activate at the same time for each of the chosen days.

The duration is set in minutes and can last from 10 minutes to 600 minutes. The duration is 120 minutes by default.

The desired temperature can be set between 10 °C and 110 °C

ECL Comfort 210 / 296 / 310, communication description

but is typically around 80 °C. The anti-bacteria function is turned off by writing the value 9 to the desired temperature setting.

Table 6-7:

Setting	Value	Address (if DHW is circuit 2)
Day	0-127	12122
Start time	0-47	12123
Duration [m]	10-600	12124
Desired temperature [°C]	9-110	12125

The addresses in the table above refer to circuit 2. For circuit 1 the addresses are from 11122 to 11125, for circuit 3 the addresses are from 13122 to 13125 and so on

- The anti-bacteria function is not active if the frost protection mode is active.

6.9 Holiday

The address range for holiday settings is from 10700 to 10839. Table 6-8 shows how a schedule consists of a mode (mode from Table 6-9 depending on application), a start time (day-month-year) and an end time (day-month-year) as well as the addresses to change them. Up to 20 schedules can be defined but typically less will actually be used depending on the application. See the application instructions for information about which holiday schedules belong to the specific circuits.

The end date must be in the future compared to the ECL's current date otherwise the holiday mode will be cancelled.

The holiday mode must be written after the start and end dates. If the mode is written before then the holiday period will perhaps not be accepted if the old end date is in the past.

Table 6-8: Addresses for holiday schedules

	Mode	Start day	Start month	Start year	End day	End month	End year
Schedule P1	10700	10701	10702	10703	10704	10705	10706
Schedule P2	10707	10708	10709	10710	10711	10712	10713
Schedule P3	10714	10715	10716	10717	10718	10719	10720
Schedule P4	10721	10722	10723	10724	10725	10726	10727
...
Schedule P20	10833	10834	10835	10836	10837	10838	10839

Maximum start or end year is 2050.

Table 6-9: Modes for holiday schedules

Operating mode	Code	Display symbol
Scheduled operation (holiday off)	0	

ECL Comfort 210 / 296 / 310, communication description

Constant comfort temperature	1	
7 – 23h Comfort temperature	2	
Constant setback temperature	3	
Frost protection / standby	4	

It depends on the specific application or circuit whether frost protection or standby mode is available.

A holiday period is only active if the circuit is in scheduled operating mode.

6.10 Alarm

PNU 1024 and 1025 holds the alarm status bitmask. The meaning of the alarm numbers is specific to the application. Alarm number 1 corresponds to PNU 1025 bit 0.

The ECL display can be used to show the alarm numbers, e.g. PNU 1040 – 1071 hold the status of each individual alarm ID 1 – 32.

A non-zero value indicates an alarm.

Example:

Alarm ID 18 has PNU 1057.

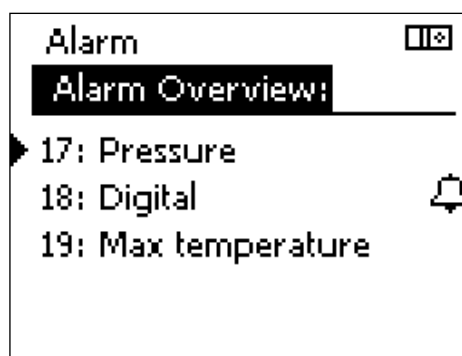

6.11 Energy meter data, M-bus (from version 1.10)

The ECL Comfort 296 / 310 allows communication with up to 5 energy meters via M-bus. The M-bus readout is based on the EN-1434 standard.



Danfoss recommends that AC supplied energy meters are used for M-bus communication.

Use of a battery supplied energy meter will normally shorten the battery life-time. Consult the specific manufacturer for details about battery life-time and the allowed data exchange rate.

M-bus configuration

PNU	Description	
5997	M-bus Baud rate	0: 300 (default) 1: 600 2: 1200 3: 2400
5998	M-bus command request	0: None 1: Init (re-initialization)

ECL Comfort 210 / 296 / 310, communication description

		2: Scan for energy meter
5999	M-bus state	0: Reset 1: Init 2: Scanning 3: Idle (collecting data if setup is present)

The available data from an energy meter depends on selected 'Type' and what the energy meter supports. See {Appendix} for further description.

Base PNU	
6000	Energy meter 1
6050	Energy meter 2
6100	Energy meter 3
6150	Energy meter 4
6200	Energy meter 5

ECL Comfort 210 / 296 / 310, communication description

PNU offset	Description	Default
0	Address	255, 0 – 254 are valid (251 – 254 have special function. Only use 254 if one meter is attached)
1	Type	0 : Generic small data set, small units 1: Generic small data set, large units 2: Generic large data set, small units 3: Generic large data set, large units 4: Volume & Energy only data set
2	Scan time in seconds	60
3	ID / Serial	
4		
5	Reserved	
6	Flow temp. [0.01 °C]	
7	Return temp. [0.01 °C]	
8	Flow [0.1 l/h]	
9		
10	Power [0.1 kW]	
11		
12	Acc. Volume [0.1 m ³]	
13		
14	Acc. Energy [0.1 kWh]	
15		
...		
49	Reserved	0

When two PNU are used, the first contains the high word information and the last the low word information.

Example:

Energy meter 3 ID / Serial is found by combining PNU 6103 and 6104, if

PNU 6103 = 0x00A7 (hex)

PNU 6104 = 0xFEE3 (hex)

This gives ID / Serial 11009763

Energy meter PNU Example:

Energy meter 3 Flow temperature PNU = 6100+6 = 6106.

See the type descriptions in section "Energy meter type descriptions"

ECL Comfort 210 / 296 / 310, communication description

6.11.1 Installation process

The ECL Comfort 296 / 310 will NOT automatically search for M-bus devices. The M-bus addresses can either be set directly (PNU offset 0, e.g. 6000) or the ECL Comfort 296 / 310 can search for devices via the "SCAN" function.

ECL display examples:

Installation by setting the address directly

Adjust the address for all connected energy meters. (The primary M-bus address must be used – in some M-bus devices the address must be set).

- Adjust the type if needed.
- Adjust the scan time if needed.
- Done.

Installation by SCAN function

Set Command to SCAN.

Wait until all energy meters are found. This can be observed in the Address fields for the respective energy meters.

When all energy meters have been found, the SCAN function can be ended by setting the Command to INIT. Alternatively wait for the SCAN function to end automatically – this takes about 12 minutes.

- Adjust the type if needed.
- Adjust the scan time if needed.

When an energy meter address or type is changed, the M-bus performs a (re-)initialization, where M-bus values are reset. Values will appear again when the state is in IDLE.

System	
M-bus config:	
Energy Meter 4	
M-bus address	54
Scan time	60 s
Type	0
ID	34489746

Energy Meters	
Energy Meter 4:	
ID	34489746
Flow T	75.5 °C
Return T	29.9 °C
Flow	610.0 l/h
Power	32.1 kW

6.12 System information parameters

The system information parameters include information about types and versions. The parameters can be found in the parameter list in the appendix. Only the ones with a special encoding/decoding are described here.

Hardware no.

PNU 34 holds the hardware revision number. It is returned as a 2-byte number where the first byte is the major version number and the second byte is the minor version number.

For example, the decimal number 16642 is returned: The hardware revision number is then found as the first byte as Unicode I hexadecimal format.

Unicode 0x41 corresponds to A, Unicode 0x42 corresponds to B, and Unicode 0x43 corresponds to C etc.

The controller from the example is consequently a revision A 2 hardware.

Hardware	= 16642
	= 0x4102
	= 0x41.0x02
	= A.2

ECL Comfort 210 / 296 / 310, communication description

Software no.

PNU 35 holds the software version number. It is returned as a 2-byte number where the first byte is the major version number and the second byte is the minor version number.

For example, the number 257 is returned.

Software	= 257
	= 0x0101
	= 0x01.0x01
	= 1.01

Build no.

PNU 8 holds the software build number. Version 1.00 has built number 2410. Later versions will have a higher build numbers.

Production time

PNU 2099 holds the production week and year. It is returned as a 2-byte decimal number which must be converted to another format. The first byte is the year and the second byte the week.

For example, the number 2563 is returned:
The production year is then found as shown.

The controller from the example is then produced during week 3 in the year 2010.

Production time	= 2563
	= 0x0A03
Production year	= 2000 + 0x0A
	= 2000 + 10
	= 2010
Production week	= 0x03
	= 03

Application name and version

The application name and version can be read on PNU 2060-2063. Application prefix can be read on PNU 2060, type number can be read on PNU 2061, sub number can be read on PNU 2062 and application version can be read on PNU 2063.

The application version consists of a major number and a minor number. The minor number is usually not used because it is only for very minor changes in the application. If an error has been corrected or a new setting has been added to the application, then it will be the major number that is changed. The minor number is only changed if cosmetic changes in the code itself have been made.

At time of writing all released applications have prefix A, but other prefixes are planned for the future.

Code no.

PNU 19 holds the code number for the product. Use 087H as prefix.

Example for an A214.1 V01 (02):

Application prefix	= 65
	= 0x41
	= A
Application type number	= 214
Application typesub number	= 1
Application version	= 258
	= 0x0102
	= 0x01.0x02
	= 1.02

087H3020	is for ECL Comfort 210, 230 V
087H3024	is for ECL Comfort 210, 24 V
087H3030	is for ECL Comfort 210B, 230 V
087H3034	is for ECL Comfort 210B, 24 V
087H3040	is for ECL Comfort 296 / 310, 230 V
087H3044	is for ECL Comfort 296 / 310, 24 V
087H3050	is for ECL Comfort 310B, 230 V
087H3054	is for ECL Comfort 310B, 24 V

Serial number

The ECL controller's serial number can be read on PNU 36 and 37.

PNU 36	= 1
PNU 37	= 215

ECL Comfort 210 / 296 / 310, communication description

Serial no. = 1 & 215 = 0x0001 & 0x0215 = 0x00010215 = 66069
--

ECL Comfort 210 / 296 / 310, communication description

ECA extension

Serial number, code number, software version and hardware version can be read for an attached ECA 32 or other expansion.

The formats are just as for the ECL controller.

Code no. type is reserved for future use, currently 0 is always read.

If no extension modules are attached, the PNU will return 0.

3rd and 4th extension are reserved for future use but not yet implemented.

Read PNU 10213 to check whether an ECA 30/31 unit is attached as HMI A, or PNU 10216 to check whether an ECA 30/31 unit is attached as HMI B. If no room unit is attached, the value 19200 will be returned.

ECA extension	Parameter	PNU
1 st extension	Serial no.	2100-2101
	Software	2102
	Hardware	2103
	Code no. type	2104
	Code no	2105
2 nd extension	Serial no.	2110-2111
	Software	2112
	Hardware	2113
	Code no. type	2114
	Code no	2115
3 rd extension (reserved)	Serial no.	2120-2121
	Software	2122
	Hardware	2123
	Code no. type	2124
	Code no	2125
4 th extension (reserved)	Serial no.	2130-2131
	Software	2132
	Hardware	2133
	Code no. type	2134
	Code no	2135

6.13 System commands

PNU 1, System command:

Value	Command	Comment
2	Reset internal ECL log	Also reset during application installation

PNU 2097, Wink display back light in seconds. Write 0 to abort active wink. If an ECA 30/31 is connected to the ECL, the ECA will also wink.

6.14 Output status, Manual output status and Output override

The outputs are controlled by one of the following sources

- Manual state
- Override state
- Regulation

The resulting value can be read in the output's "status"

When the controller is in Manual mode it controls all output used by the specific application. The manual control has priority.

When the controller is not in Manual mode, the output can be controlled by "Output override".



It is not possible to set the manual output state from the Modbus interface – it can only be done via the ECL display (or ECA 30/31 remote unit).

6.14.1 Output status (from version 1.10)

PNU 3998 and 3999 holds a read only bit mask for all ECL outputs.

ECA 32 ²			Bit 15	Bit 14	Bit 13	Bit 12

² From version 1.20

ECL Comfort 210 / 296 / 310, communication description

			<i>Relay4</i>	<i>Relay3</i>	<i>Relay2</i>	<i>Relay1</i>
ECL	Bit 11	Bit 10	Bit 9	Bit 8	Bit 7	Bit 6
	<i>Relay6</i>	<i>Relay5</i>	<i>Relay4</i>	<i>Relay3</i>	<i>Relay2</i>	<i>Relay1</i>
	Bit 5	Bit 4	Bit 3	Bit 2	Bit 1	Bit 0
	<i>Triac6</i>	<i>Triac5</i>	<i>Triac4</i>	<i>Triac3</i>	<i>Triac2</i>	<i>Triac1</i>

See the application description for determining the usage of each output.

Output status for triac 1-6 can be read on PNU 4000-4005

Output status for relay 1-6 can be read on PNU 4006-4011

Output status for ECA 32 relay 1-4 can be read on PNU 4012-4015

Output status for ECA 32 AO 1-3 can be read on PNU 4016-4018

Output status is the current "value" for the output (independent of the source: manual, override or regulation).

The scale for PNU 4016-4018 is 10. I.e. if the read output value is 119 then the output is opened 11.9%. The ECL will only show 11 % because the decimal is not shown.

6.14.2 Manual status (read only)

If a manual status is non-zero it controls, the respective output.

Manual status can be read in PNU 4020 – 4031 (Triac 1, Triac 2, ..., relay 6).

Manual status for ECA 32 relay 1-4 can be read on PNU 4032-4035

Manual status for ECA 32 AO 1-3 can be read on PNU 4036-4038

Manual value for ECA 32 AO 1-3 can be read on PNU 4056-4058

The scale for PNU 4056-4058 is 10. I.e. if the read output value is 119 then the output is opened 11.9%.

(The ECL will only show 11 % because the decimal is not shown)

For 3-point motorized control valve value output, the first PNU holds the value, e.g. PNU 4020 for motorized control valve 1.

Value	Display value	Comment
0	AUTO	Follows regulation or output override value
1	STOP	The motorized control valve is not moved
2	CLOSE	The motorized control valve is moved downwards
3	OPEN	The motorized control valve is moved upwards

For relay output the following values apply:

Value	Display value	Comment
0	AUTO	Follows regulation or output override value
1	OFF	The pump is turned off
2	ON	The pump is turned on

6.14.3 Output override

Output override can be used to control output in the ECL when it is **not** in manual mode. If the ECL is in manual mode, the override settings are not necessarily true, as it depends on the output the application uses, and it can therefore not be relied upon to show the actual status of the output. Output override can also be used to control outputs that are not used in a specific application and those outputs will therefore not be overruled if the ECL is in manual mode!

Output override state can be set in

PNU 4060 – 4071 (ECL Triac 1, ..., Triac 6, ..., relay 1, ..., relay 6).

PNU 4072 – 4075 (ECA 32 relay 1, ..., relay 4)

PNU 4076 – 4078 (ECA 32 AO 1, ..., AO 3 **state**)

PNU 4096 – 4098 (ECA 32 AO 1, ..., AO 3 **value**)

Values are formatted equal to manual status.

For ECA 32 analogue outputs there are additional override values which can be read on PNU 4096-4098.

The scale for PNU 4056-4058 and 4096-4098 is 10. I.e. if the read output value is 119 then the output is opened 11.9%.

(The ECL will only show 11 % because the decimal is not shown)

6.15 Configurable input

The ECL Comfort 210 has two configurable input, i.e. S7-S8, whereas the ECL Comfort 296 / 310 has four configurable input, i.e. S7-S10.

Sensor input S7 -S10 are configurable so that they can be connected to different I/O types depending on application.

It is possible to set input options in order to accommodate various output signal types from different hardware. To set a sensor input to a specific type or input option, write the type (1-6) or option (0-3) to the address as indicated in Table 6-10 or Table 6-11.



The tables are only guiding and some applications may have limitations if the input are pre-configured. Please consult the installation guide for the application key for further information.

ECL Comfort 210 / 296 / 310, communication description

Table 6-10:

Sensor	S7	S8	S9	S10	S11*	S12*
PNU	4100	4101	4102	4103	4104	4105
Type: 1 = Pt1000	✓	✓	✓	✓	✓	✓
Type: 2 = 0-10 V ADC	✓	✓	✓	✓	✓	✓
Type: 3 = Digital	✓	✓	✓	✓	✓	✓
Type: 4 = Flow switch		✓				
Type: 5 = Pulse	✓					
Type: 6 = Frequency	✓					

*S11 and S12 are only available if an internal I/O module is installed

Table 6-11:

Sensor	S7	S8	S9	S10	S11*	S12*
PNU	4120	4121	4122	4123	4124	4125
Option: 0 = None	✓	✓	✓	✓	✓	✓
Option: 1 = Pull up ³	✓	✓	✓	✓	✓	✓
Option: 2 = Cap load ⁴	✓	✓	✓	✓	✓	✓
Option: 3 = Pull up & Cap load	✓	✓	✓	✓	✓	✓
Option: 255 = Default						

* S11 and S12 are only available if an internal I/O module is installed

A write error will be returned if the application does not allow the input configuration to be changed.

6.15.1 ECA 32 Extension I/O module

If an ECA 32 I/O module is installed, more sensors are available. Sensor input S13-S14 are configurable so that they can be connected to a Pt 1000 temperature sensor or a 0-10 V digital input, depending on application.

Input S17-S18 are configurable so that they can be connected to a Pt1000 temperature sensor, a 0-10 V digital input, a dry contact or a pulse (200 Hz) input, depending on application.

To set a sensor input to a specific type or input option write the type (1-6) or option (0-3) to the address as indicated in Table 6-12 or Table 6-13.



The tables are only guiding and some applications may have limitations if the inputs are pre-configured. Please consult the application instructions for further information.

Table 6-12:

Sensor	S13	S14	S15	S16	S17	S18
PNU	4106	4107	4108	4109	4110	4111
Type: 1 = PT1000	✓	✓	✓	✓		
Type: 2 = 0-10V ADC	✓	✓	✓	✓		
Type: 3 = Digital	✓	✓	✓	✓		
Type: 4 = Flow switch						
Type: 5 = Pulse					✓	✓
Type: 6 = Frequency					✓	✓

³ Pull up enables a pull-up resistor to +12V

⁴ Cap load enables a capacitor load. This is used to keep mechanical contact points clean

ECL Comfort 210 / 296 / 310, communication description

Table 6-13:

Sensor	S13	S14	S15	S16	S17	S18
PNU	4126	4127	4128	4129	4130	4131
Option: 0 = None	✓	✓	✓	✓	✓	✓
Option: 1 = Pull up	✓	✓	✓	✓	✓	✓
Option: 2 = Cap load	✓	✓	✓	✓	✓	✓
Option: 3 = Pull up & Cap load	✓	✓	✓	✓	✓	✓
Option: 255 = Default						

A write error will be returned if the application does not allow the input configuration to be changed.

6.16 Unit and pulse

The unit setting (PNU 1X115) is a special setting which depends on the value of the pulse setting (PNU 1X114). See in the table below what the unit value means depending on the pulse value.

	Pulse = 0	Pulse > 0
Unit = 0	L/h	mL, L/h
Unit = 1	L/h	L, L/h
Unit = 2	m3/h	mL, m3/h
Unit = 3	m3/h	L, m3/h
Unit = 4	kW	Wh, kW
Unit = 5	kW	kWh, kW
Unit = 6	MW	kWh, MW
Unit = 7	MW	MWh, MW
Unit = 8	GW	MWh, GW
Unit = 9	GW	GWh, GW

6.17 Limiter status (from version 1.32)

The limiter information holds information about what is influencing the temperature reference.



E.g. if room influence is active and room temperature is higher than room set-point, the reference will be turned down.

The limiter value indicates which way the reference is moved – in some cases it is not known in advance and both directions are selected.

The limiter information is interpreted as a bit mask.

Word	Limiter
Word 1	Return lim. (bit 0-1) Room lim. (bit 2-3) Wind influence Res Res Res Parallel priority Flow / power lim. (bit 14-15)
Word 2	Holiday (bit 0-1) Ext. override ECA override Anti-bacteria Boost Ramp Slave, demand Heating cut-out (bit 14-15)
Word 3	DHW priority (bit 0-1) DHW influence SCADA offset SCADA override Ext. desired T Res Res Res (bit 14-15)
Word 4	Res

Circuit	PNU
Circuit 1	4220 – 4223
Circuit 2	4224 – 4227
Circuit 3	4228 – 4231
Circuit 4	4232 – 4235

Value	"Symbol" & meaning
0	
1	 Increased reference
2	 Decreased reference
3	 Changed reference

7. Modbus protocol

The ECL Comfort 210/296/310 controllers are Modbus compliant devices. The controller supports a number of public function codes. The Modbus application data unit (ADU) is limited to 240 bytes.

Supported public function codes

- 03 (0x03) Read Holding Registers
- 04 (0x04) Read Input Registers
- 06 (0x06) Write Single Register

7.1 Function codes

Table 7-1: Function codes

Function	Function code	Comments
Read PNU	0x03 or 0x04	Single PNU/register only
Write PNU	0x06	Single PNU/holding register only

7.1.1 Modbus messages

7.1.1.1 Read read-only parameter (0x03)

This function is used to read the value of an ECL Comfort read-only parameter number. Values are always returned as integer values and must be scaled according to the parameter definition.

Requesting a quantity of more than 123 parameters in sequence gives an error response. Requesting non-existing parameter number(s) will give an error response.

Request

Function code	1 byte	0x03
Start PNU	2 bytes	0x0001 – 0xffff
Quantity N of PNU	2 bytes	0x0001 – 0x007B

Response

Function code	1 byte	0x03
Byte count	1 byte	2 – 246
PNU data value	2 bytes	0x0000 – 0xffff

Error

Function code	1 byte	0x83
Error code	2 bytes	1: Illegal Function 2: Parameter not available 3: Quantity exceeds limit 4: Invalid telegram

The request/response is Modbus compliant when reading a sequence of parameters (read input register).

7.1.1.2 Read parameters (0x04)

This function is used to read the value of an ECL Comfort parameter number. Values are always returned as integer values and must be scaled according to the parameter definition.

Requesting a quantity of more than 123 parameters gives an error response. Requesting non-existing parameter number(s) will give an error response.

Request

Function code	1 byte	0x04
Start PNU	2 bytes	0x0001 – 0xffff
Quantity N of PNU	2 bytes	0x0001 – 0x007B

Response

Function code	1 byte	0x04
Byte count	1 byte	2 - 246
PNU data value	2 bytes	0x0000 – 0xffff

Error

Function code	1 byte	0x84
Error code	2 bytes	1: Illegal Function 2: Parameter not available 3: Quantity exceeds limit 4: Invalid telegram

The request/response is Modbus compliant reading a sequence of parameters (Read input register).

7.1.1.3 Write parameter number (0x06)

This function is used to write a new setting value to an ECL Comfort parameter number. Values must be written as integer values and must be scaled according to the parameter definition.

Attempts to write a value outside the valid range will give an error response. The minimum and maximum values must be obtained from the instructions for ECL Comfort controller.

Request

Function code	1 byte	0x06
Write PNU	2 bytes	0x0001 – 0xffff
New PNU value	2 bytes	0x0000 – 0xffff

Response

Function code	1 byte	0x06
Write PNU	2 bytes	0x0001 – 0xffff
New PNU value	2 bytes	0x0000 – 0xffff

ECL Comfort 210 / 296 / 310, communication description

Error

Function code	1 byte	0x86
Error code	2 bytes	1: Illegal Function 2: Parameter not available 3: Illegal value 4: Invalid telegram / PNU not writable

The request/response is Modbus compliant when writing a parameter (Write single register).

7.2 Broadcasts

The modules support Modbus broadcast messages (unit address = 0).

Command/function where a broadcast is usable

- Write ECL parameter (0x06)

The Modbus address 254, service address, can be used if only one ECL is connected. For the address 254 all commands can be used.

7.3 Error codes

For specific details, please consult the specifications

- Modbus Application Protocol V1.1a.
- Modbus over Serial Line, Specification & Implementation guide V1.0

both of which can be found on <http://www.Modbus.org/>

7.4 Modbus/TCP

The ECL Comfort 296 / 310 supports Modbus over TCP connections so that it is possible to send and receive Modbus commands over an Ethernet network. The Modbus traffic must be sent to port 502.

7.5 Communication example

The following examples show how the communication looks from the low level on the serial line
ECL Modbus address 1 is used.

Read of Comfort set-point, PNU 11180

The register address is PNU-1, i.e. 11179 = 0x2BAB

Complete request & response⁵:

01 03 2B AB 00 01 FC 0E

01 03 02 00 C8 B9 D2

The value 0x00C8 is 200, scale of the set-point is 10, i.e. the values are 20,0

Read of Sensor S2, PNU 10202

The register address is PNU-1, i.e. 10202 = 0x 27DA

Complete request & response:

⁵ The two last hexadecimal values are the CRC

ECL Comfort 210 / 296 / 310, communication description

01 03 27 D9 00 01 5F 45

01 03 02 08 60 BF AC

The value 0x0860 is 2144, scale of the sensor is 100, i.e. the values are 21,44 (21,5)

8. ECL 485 bus description

The ECL 485 bus is used to connect ECL Comfort 210/296/310 and ECA 30/31 with each other in a master/slave system.

The master/slave communication exchanges information between the devices, e.g. time and date, outdoor temperature, refill request⁶ etc.

The ECL 485 bus wiring must be done similar to a Modbus RS-485 network, i.e. devices must be connected in a daisy chain network (polarization is done by the ECL master, address 15). The recommended network installation procedure is as in section 8.1.2.

The total cable length of maximum 200 meters (all devices incl. the internal ECL 485 communication bus) should not be exceeded. Cable lengths of more than 200 meters may increase noise sensitivity (EMC).

² Refill is a functionality for the A231, A331, A361 and A368 applications



Only Danfoss District Energy products developed for the ECL 485 bus can be used.



No third party products can be used!

8.1 Installation of the ECL 485 network

The ECL 485 bus is similar to Modbus concerning that an address is to be used only once in the network. Using the same address multiple times will cause malfunction. It is recommended that all of the devices are installed sequentially to ensure that they will not conflict with each other.

Address 15 is reserved for the master controller.

Addresses 1-9 are reserved for slave controllers.

Address 0 is reserved for listening slaves. Listening slaves can only listen for master broadcasts and cannot broadcast anything to the master. Blind controllers cannot be used as listening slaves.

⁶ Refill is a functionality for the A231, A331, A361 and A368 applications

8.1.1 ECL Comfort 210B and ECL Comfort 310B application installation

The ECA 30/31 can be used for installation of an application in an ECL controller without display and dial (also called blind/B/type B/HMI less).

Installation of the application must be done in a point-to-point connection between the ECL and ECA 30/31.

If necessary, disconnect other ECL or ECA products from the ECL 485 bus

Connect the ECL Comfort 210B / 310B directly to the ECA 30/31

If necessary, set the ECA 30/31 slave address to 'A' and the connection address to 15

The ECA 30/31 will now act as an ECL with display and dial. Select the application normally

When the application is installed the ECL will be set to ECL 485 master (address 15)

If necessary, adjust the ECL Comfort 210B / 310B's ECL 485 address and connect it to the ECL 485 network again.

8.1.2 Recommended installation sequence

Before starting the electrical wiring and installation, it is recommended that a network plan is made which specifies ECL 485 address. If the ECL controllers are to be used in a SCADA system, it is also recommended to include the network plan.

1. Setup all the hardware with all cables and wires for the controllers and room units
 - a. If necessary, ensure that terminations are present
2. Turn on power to the intended master controller, ECL with ECL 485 address 15
 - a. If necessary, install application
 - b. Check that everything (including all addresses (ECL 485, Modbus & IP) is as intended
3. Turn on power to room units one by one
 - a. Check that the slave and ECL addresses are as intended
 - b. Copy application if needed from controller.
4. Turn on power to the slave controller with the lowest address
 - a. If the controller is without HMI, type B, the ECL must be configured separately
 - b. If necessary, install application and make sure the set ECL 485 address

Repeat step 4 until all controllers are installed.

8.1.3 ECA 30/31 application copy

The ECA 30/31 will automatically detect a new application after 30 seconds when it connects to a controller that has been updated.

The ECA 30/31 can hold 10 applications in its memory which is sufficient for a network with one master and nine slaves.

The copying process takes about 2–3 minutes. If two ECA 30/31 are used at the same time the process will take longer for the ECA 30/31 that started last.

9. Appendix

9.1 References

[1]	http://www.Modbus.org/	Modbus homepage The Modbus standards can be downloaded from here

9.2 Definitions and Abbreviations

	Description
SW	Software
HW	Hardware
HMI	Human Machine Interface
ECL	ECL Comfort 210, ECL Comfort 296 or ECL Comfort 310
B type	ECL Comfort 210B or ECL Comfort 310B, ECL without HMI (display and dial)
ECA	ECA 30 Room unit module
Room Unit	ECA 30 module
SCADA	Supervisory Control and Data Acquisition, common name for (Modbus) network solutions
PNU	Parameter NU number, is referring to the Modbus register address Note the PNU starts with 1, whereas Modbus registers starts with 0

9.3 Energy meter type descriptions

The following shows the possible types and the related values. Note that some energy meter only supports a limited number of parameters.

The type 0 & 1 values should be supported by most energy meters.

Changes to the Type settings causes meter value reset, i.e. it should be set once.

"PNU offset"	Type 0 (default)	Type 1
0	Address	Address
1	Type	Type
2	Scan time	Scan time
3	ID / Serial	ID / Serial
4	- low part	- low part
5	Reserved	Reserved
6	Flow temp. [0,01 °C]	Flow temp. [0,01 °C]
7	Return temp. [0,01 °C]	Return temp. [0,01 °C]
8	Flow [0,1 l/h]	Flow [0,1 l/h]
9	- low	- low
10	Power [0,1 kW]	Power [0,1 kW]
11	- low	- low
12	Acc. Volume [0,1 m3]	Acc. Volume [0,1 m3]
13	- low	- low
14	Acc. Energy [0,1 kWh]	Acc. Energy [0,1 MWh]
15	- low	- low
16		
17		
18		
19		
20		
21		
22		
23		
24		

ECL Comfort 210 / 296 / 310, communication description

"PNU offset"	Type 2	Type 3
0	Address	Address
1	Type	Type
2	Scan time	Scan time
3	ID / Serial	ID / Serial
4	- low part	- low part
5	Reserved	Reserved
6	Flow temp. [0,01 °C]	Flow temp. [0,01 °C]
7	Return temp. [0,01 °C]	Return temp. [0,01 °C]
8	Flow [0,1 l/h]	Flow [0,1 l/h]
9	- low	- low
10	Power [0,1 kW]	Power [0,1 kW]
11	- low	- low
12	Acc. Volume [0,1 m3]	Acc. Volume [0,1 m3]
13	- low	- low
14	Acc. Energy [0,1 kWh]	Acc. Energy [0,1 MWh]
15	- low	- low
16	Tariff1 Acc. Energy [0,1 kWh]	Tariff1 Acc. Energy [0,1 MWh]
17	- low	- low
18	Tariff2 Acc. Energy [0,1 kWh]	Tariff2 Acc. Energy [0,1 MWh]
19	- low	- low
20	Up time [d]	Up time [d]
21	Current time [m-bus defined structure]	Current time [m-bus defined structure]
22	- low	- low
23	Error status [heat meter defined bitmask]	Error status [heat meter defined bitmask]
24		

"PNU offset"	Type 4	
0	Address	
1	Type	
2	Scan time	
3	ID / Serial	
4	- low part	
5	Reserved	
6	Acc. Volume [0,1 m3]	
7	- low	
8	Acc. Energy [0,1 kWh]	
9	- low	
10	Acc. Volume2 [0,1 m3]	
11	- low	
12	Acc. Energy2 [0,1 kWh]	
13	- low	
14	Acc. Volume3 [0,1 m3]	
15	- low	
16	Acc. Energy3 [0,1 kWh]	
17	- low	
18	Acc. Volume4 [0,1 m3]	
19	- low	
20	Acc. Energ4y [0,1 kWh]	
21	- low	
22		
23		
24		

9.4 Good behavior in designing a district heating Modbus network

In this chapter some basic design recommendations are listed. These recommendations are based on communication in heating systems. This chapter is built as an example of a network design. The example can vary from a specific application. The typical requirement in heating systems is to get access to a number of similar components and to be able to make a few adjustments. The illustrated performance levels might decrease in real systems.

In general, it can be said that the network master controls the performance of the network.

9.4.1 Considerations before implementing communication

It is very important to be realistic when network and performance are specified. Some considerations have to be made in order to secure that important information is not blocked because of a frequent update of trivial information. Keep in mind that heating systems typically have long time constants, and hence can be polled less frequent.

9.4.2 Basic needs for information in SCADA systems

The ECL Comfort controller can support a network with some pieces of information concerning a heating system. It might be a good idea to consider how to split up the traffic that these different information types generate.

- Alarm handling: Values that are used to generate alarm conditions in the SCADA system.
- Error handling: In all networks errors will occur, error means time out, check of sum error, retransmission and extra traffic generated. The errors might be caused by EMC or other conditions, and it is important to reserve some bandwidth for error handling.
- Data logging: Logging of temperature etc. in a database is a function which typically is non-critical in a heating system. This function must normally run all the time "in the background". It is not recommended to include parameters such as set-points and other parameters that require user interaction to change.
- Online communication: This is direct communication with a single controller. When a controller is chosen (e.g. service picture in a SCADA system) the traffic to this single controller is increased. Parameter values can be polled frequently in order to give the user fast response. When the online communication is no longer needed (e.g. leaving the service picture in a SCADA system), the traffic must be set back to the normal level.
- Other devices: Do not forget to reserve bandwidth for devices from other manufacturers and future devices. Heat meters, pressure sensors, and other devices have to share the network capacity.

The level for different kinds of communication types must be considered (an example is given in Figure 9.1).

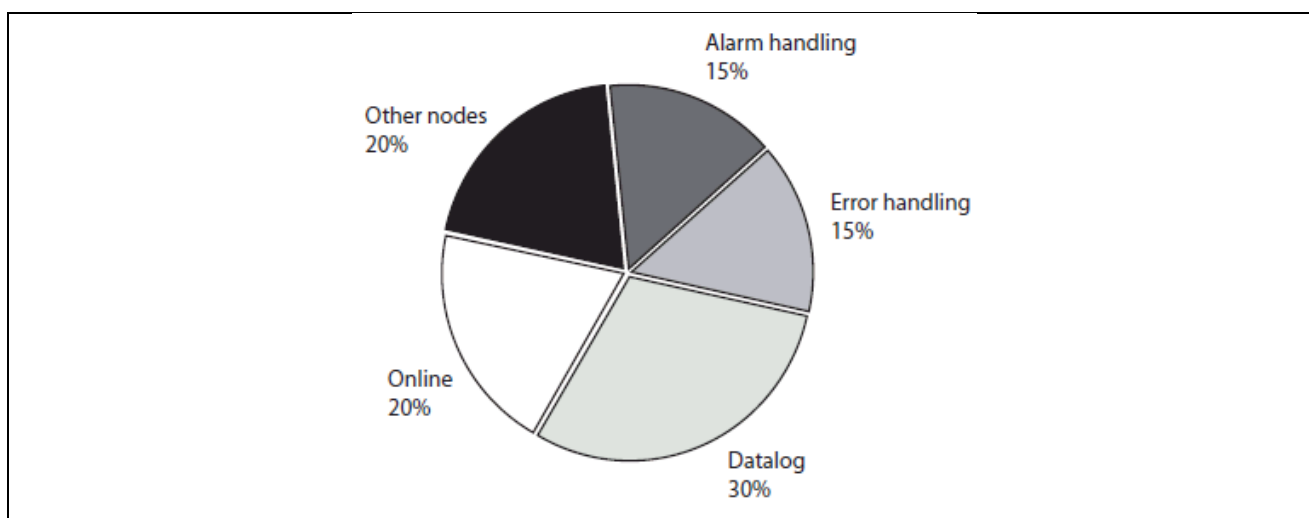

Figure 9-1

9.4.3 Final number of nodes in the network

At start-up the network has to be designed with due consideration to the final number of nodes and the network traffic in the network.

ECL Comfort 210 / 296 / 310, communication description

A network with few controllers connected might run without any bandwidth problems at all. When the network is increased, however, bandwidth problems might occur in the network. To solve such problems, the amount of traffic has to be decreased in all controllers, or extra bandwidth can be implemented.

9.4.4 Parallel network

If a large number of controllers is used in a limited area with a limited length of the communication cable, parallel network might be a way to generate more bandwidth.

If the master is located in the middle of the network, the network can easily be split-up into two and the bandwidth can be doubled.

9.4.5 Bandwidth considerations

Modbus is based on a command/query and response, meaning that the SCADA system sends a command/query and the ECL controller respond to this. Do not attempt to send new commands before a response is received or the timeout expires.

In a Modbus network it is not possible to send commands/queries to different devices at the same time (except broadcast). One command/query – response must be completed before the next can be started. It is necessary to think about the roundtrip time when designing the network. Larger networks will inherently have larger roundtrip times.

If multiple devices must have the same information, it is possible to use the broadcast address 0. Broadcast can only be used when no response is necessary, i.e. by a write command.

The network must always be configured as a daisy chained network, see the three examples from a very simple network to more complex networks in section 'Network layout'.

ECL Comfort 210 / 296 / 310, communication description

9.5 Parameter list (PNU list)

The parameter list is an overall description of possible parameters. The actual available parameters depend on the used application, e.g. A266.1 contains more parameters than the A230.1 application.

For details consult the installation guide for the application key.

Example of typical PNU of interest for an A266.1

A266.1 example showing the most typical PNU⁷ of interest

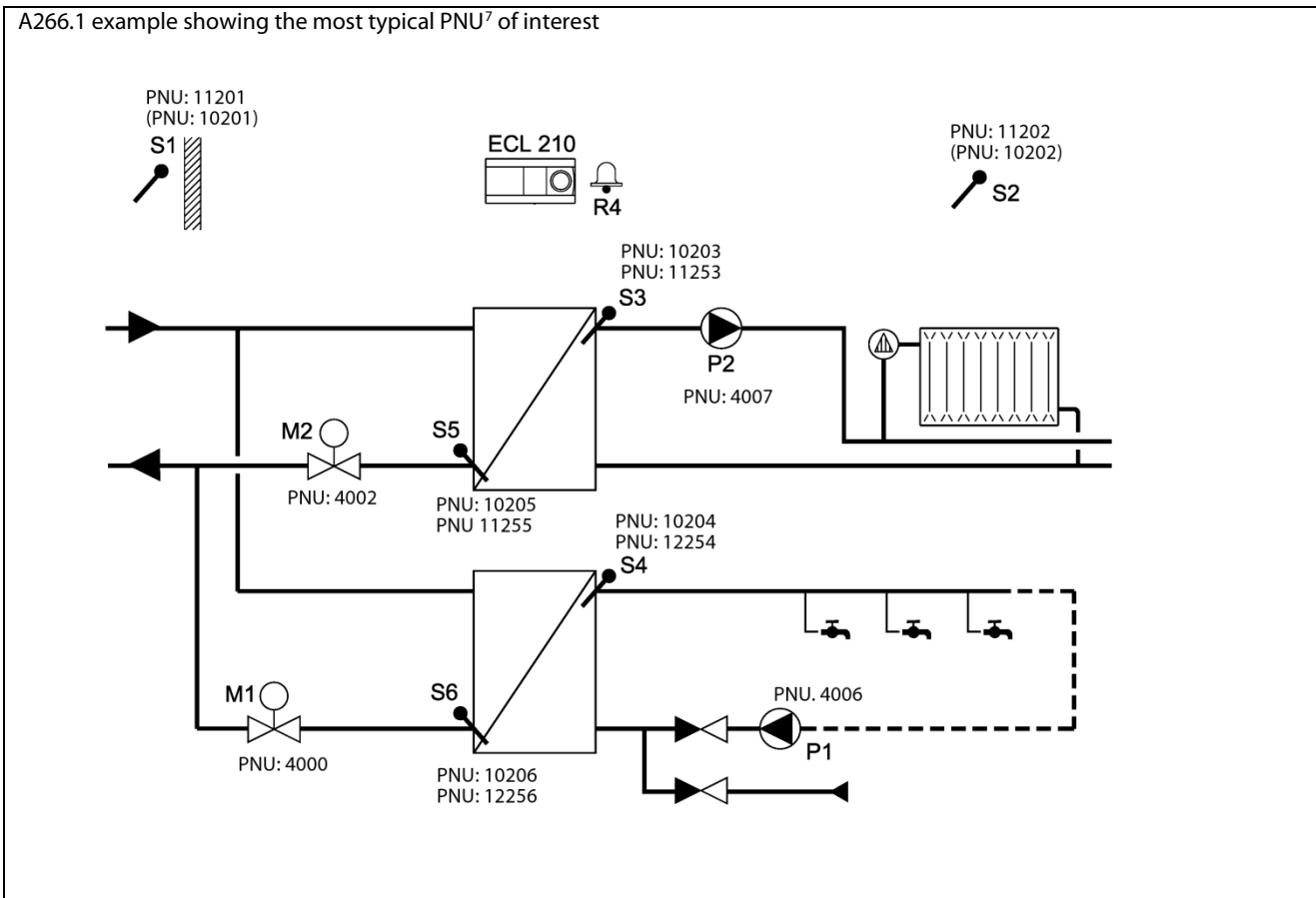

Further most typical PNU of interest

	PNU	
Circuit 1	4201, 4211	Mode and status
	11180, 11181	Comfort / Saving room set-point
Circuit 2 (DHW)	4202, 4212	Mode and status
	12190, 12191	Comfort / Saving DHW set-point

⁷ The (PNU), e.g. (PNU: 10202) are the sensor value.

ECL Comfort 210 / 296 / 310, communication description

Note: The list only contains circuit I examples. Circuit II, III and IV will use equal numbers, with 12xxx, 13xxx, 14xxx prefix.

Any scale information in the parameter list should only be used as a guideline, as this may change with Application.

ECL Comfort Parameter	Description	PNU	Access	Scale
ECL Sales and order number		19		
Hardware revision		34		
ECL Software version		35		
Serial high part		36		
Serial low part		37		
Modbus Network Address		38		
Modbus Baud rate		39		
Address Type (1: Static IP, 0: DHCP)		258		
IP adr. 1		278		
IP adr. 2		279		
IP adr. 3		280		
IP adr. 4		281		
Net mask 1		286		
Net mask 2		287		
Net mask 3		288		
Net mask 4		289		
Gateway adr. 1		282		
Gateway adr. 2		283		
Gateway adr. 3		284		
Gateway adr. 4		285		
Alarm field 2 – Sum alarms 17-32		1024		
Alarm field 1 – Sum alarms 1-16		1025		
Alarm field 2 – Clear alarms 17-32		1032		
Alarm field 1 – Clear alarms 1-16		1033		
Alarm Context #01		1040		
Alarm Context #02		1041		
Alarm Context #03		1042		
Alarm Context #04		1043		
Alarm Context #05		1044		
Alarm Context #06		1045		
Alarm Context #07		1046		
Alarm Context #08		1047		
Alarm Context #09		1048		
Alarm Context #10		1049		
Alarm Context #11		1050		
Alarm Context #12		1051		
Alarm Context #13		1052		
Alarm Context #14		1053		
Alarm Context #15		1054		
Alarm Context #16		1055		
Alarm Context #17		1056		
Alarm Context #18		1057		
Alarm Context #19		1058		
Alarm Context #20		1059		

ECL Comfort 210 / 296 / 310, communication description

ECL Comfort Parameter	Description	PNU	Access	Scale
Alarm Context #21		1060		
Alarm Context #22		1061		
Alarm Context #23		1062		
Alarm Context #24		1063		
Alarm Context #25		1064		
Alarm Context #26		1065		
Alarm Context #27		1066		
Alarm Context #28		1067		
Alarm Context #29		1068		
Alarm Context #30		1069		
Alarm Context #31		1070		
Alarm Context #32		1071		
ECL485 Bus address		2048		
Modbus Bias		2049		
Language		2050		
Pt1000 sensor monitor				
Sensor monitor valid mask1		2052		
Sensor monitor valid mask2		2053		
Sensor monitor error mask1		2054		
Sensor monitor error mask2		2055		
Application info				
Application prefix		2060		
Application type number		2061		
Application type sub number		2062		
Application version		2063		
Res. for further PNU's e.g. App sales number				
Wink		2097		
ECL Sales number type		2098		
ECL production date		2099		
4* Extension Device x info				
Serial High		2100		
Serial Low		2101		
SW version		2102		
HW version		2103		
Sales number type		2104		
Sales number		2105		
Device 2		2110		
...		...		
Device 4 info end		2135		
Service Pin		2150		
Extension Reset		2151		

ECL Comfort 210 / 296 / 310, communication description

ECL Comfort Parameter	Description	PNU	Access	Scale
Schedule PNU 3110 - 3675				
Schedule Monday circuit X period 1 start	Monday P1 ON	3110	R/W	
Schedule Monday circuit X period 1 stop	Monday P1 OFF	3111	R/W	
Schedule Monday circuit X period 2 start	Monday P2 ON	3112	R/W	
Schedule Monday circuit X period 2 stop	Monday P2 OFF	3113	R/W	
Schedule Monday circuit X period 3 start	Monday P3 ON	3114	R/W	
Schedule Monday circuit X period 3 stop	Monday P3 OFF	3115	R/W	
Schedule Tuesday circuit X period 1 start	Tuesday P1 ON	3120	R/W	
Schedule Tuesday circuit X period 1 stop	Tuesday P1 OFF	3121	R/W	
Schedule Tuesday circuit X period 2 start	Tuesday P2 ON	3122	R/W	
Schedule Tuesday circuit X period 2 stop	Tuesday P2 OFF	3123	R/W	
Schedule Tuesday circuit X period 3 start	Tuesday P3 ON	3124	R/W	
Schedule Tuesday circuit X period 3 stop	Tuesday P3 OFF	3125	R/W	
Schedule Wednesday circuit X period 1 start	Wednesday P1 ON	3130	R/W	
Schedule Wednesday circuit X period 1 stop	Wednesday P1 OFF	3131	R/W	
Schedule Wednesday circuit X period 2 start	Wednesday P2 ON	3132	R/W	
Schedule Wednesday circuit X period 2 stop	Wednesday P2 OFF	3133	R/W	
Schedule Wednesday circuit X period 3 start	Wednesday P3 ON	3134	R/W	
Schedule Wednesday circuit X period 3 stop	Wednesday P3 OFF	3135	R/W	
Schedule Thursday circuit X period 1 start	Thursday P1 ON	3140	R/W	
Schedule Thursday circuit X period 1 stop	Thursday P1 OFF	3141	R/W	
Schedule Thursday circuit X period 2 start	Thursday P2 ON	3142	R/W	
Schedule Thursday circuit X period 2 stop	Thursday P2 OFF	3143	R/W	
Schedule Thursday circuit X period 3 start	Thursday P3 ON	3144	R/W	
Schedule Thursday circuit X period 3 stop	Thursday P3 OFF	3145	R/W	
Schedule Friday circuit X period 1 start	Friday P1 ON	3150	R/W	
Schedule Friday circuit X period 1 stop	Friday P1 OFF	3151	R/W	
Schedule Friday circuit X period 2 start	Friday P2 ON	3152	R/W	
Schedule Friday circuit X period 2 stop	Friday P2 OFF	3153	R/W	
Schedule Friday circuit X period 3 start	Friday P3 ON	3154	R/W	
Schedule Friday circuit X period 3 stop	Friday P3 OFF	3155	R/W	
Schedule Saturday circuit X period 1 start	Saturday P1 ON	3160	R/W	
Schedule Saturday circuit X period 1 stop	Saturday P1 OFF	3161	R/W	
Schedule Saturday circuit X period 2 start	Saturday P2 ON	3162	R/W	
Schedule Saturday circuit X period 2 stop	Saturday P2 OFF	3163	R/W	
Schedule Saturday circuit X period 3 start	Saturday P3 ON	3164	R/W	
Schedule Saturday circuit X period 3 stop	Saturday P3 OFF	3165	R/W	
Schedule Sunday circuit X period 1 start	Sunday P1 ON	3170	R/W	
Schedule Sunday circuit X period 1 stop	Sunday P1 OFF	3171	R/W	
Schedule Sunday circuit X period 2 start	Sunday P2 ON	3172	R/W	
Schedule Sunday circuit X period 2 stop	Sunday P2 OFF	3173	R/W	
Schedule Sunday circuit X period 3 start	Sunday P3 ON	3174	R/W	
Schedule Sunday circuit X period 3 stop	Sunday P3 OFF	3175	R/W	
Schedule 2 - start		3210		
Schedule 2 - end		3275		
Schedule 3 - start		3310		
Schedule 3 - end		3375		
Schedule 4 - start		3410		
Schedule 4 - end		3475		
Schedule 5 - start		3510		
Schedule 5 - end		3575		
Schedule 6 - start		3610		
Schedule 6 - end		3675		

ECL Comfort 210 / 296 / 310, communication description

ECL Comfort Parameter	Description	PNU	Access	Scale
Output				
Output bit mask High word (digital outputs)		3998		
Output bit mask Low word (digital outputs)		3999		
Triac 1		4000	R	
...				
Triac 6		4005	R	
Relay 1		4006	R	
...				
Relay 6		4011	R	
ECA 32 Relay 1		4012	R	
...				
ECA 32 Relay 4		4015	R	
Manual status, Triac 1		4020	R	
Manual status, Triac 2		4021	R	
Manual status, Triac 3		4022	R	
Manual status, Triac 4		4023	R	
Manual status, Triac 5		4024	R	
Manual status, Triac 6		4025	R	
Manual status, Relay 1		4026	R	
Manual status, Relay 2		4027	R	
Manual status, Relay 3		4028	R	
Manual status, Relay 4		4029	R	
Manual status, Relay 5		4030	R	
Manual status, Relay 6		4031	R	
Manual status, ECA32 Relay 1		4032	R	
Manual status, ECA32 Relay 2		4033	R	
Manual status, ECA32 Relay 3		4034	R	
Manual status, ECA32 Relay 4		4035	R	
Manual status, ECA32 AO1		4036		
Manual status, ECA32 AO2		4037		
Manual status, ECA32 AO3		4038		
Manual values - reserve start		4040	R	
Manual value, ECA32 AO1		...		
Manual value, ECA32 AO1		4056		
Manual value, ECA32 AO1		4057		
		4058		
Manual values - reserve end		4059	R	
Override status, Triac 1		4060	RW	
Override status, Triac 2		4061	RW	
Override status, Triac 3		4062	RW	
Override status, Triac 4		4063	RW	
Override status, Triac 5		4064	RW	
Override status, Triac 6		4065	RW	
Override status, Relay 1		4066	RW	
Override status, Relay 2		4067	RW	
Override status, Relay 3		4068	RW	
Override status, Relay 4		4069	RW	
Override status, Relay 5		4070	RW	
Override status, Relay 6		4071	RW	
Override status, ECA32 Relay 1		4072	RW	
Override status, ECA32 Relay 2		4073	RW	
Override status, ECA32 Relay 3		4074	RW	
Override status, ECA32 Relay 4		4075	RW	
Override status, ECA32 AO1		4076		
Override status, ECA32 AO2		4077		
Override status, ECA32 AO3		4078		

ECL Comfort 210 / 296 / 310, communication description

ECL Comfort Parameter	Description	PNU	Access	Scale
Override values - reserve start		4080		
...		...		
Override value, ECA32 AO1		4096		
Override value, ECA32 AO2		4097		
Override value, ECA32 AO3		4098		
...		...		
Override values - reserve end		4099		
Override values - reserve start		4080		
...		...		
Override value, ECA32 AO1		4096		
Override value, ECA32 AO2		4097		
Override value, ECA32 AO3		4098		
...		...		
Override values - reserve end		4099		
Config setup				
Config type S7		4100		
Config type S8		4101		
Config type S9		4102		
Config type S10		4103		
Config type S11		4104		
Config type S12		4105		
ECA 32 Config type S13		4106		
ECA 32 Config type S14		4107		
ECA 32 Config type S15		4108		
ECA 32 Config type S16		4109		
ECA 32 Config type S17 Pulse/frequency		4110		
ECA 32 Config type S18 Pulse/frequency		4111		
Config option S7		4120		
Config option S8		4121		
Config option S9		4122		
Config option S10		4123		
Config option S11		4124		
Config option S12		4125		
ECA 32 Config option S13		4126		
ECA 32 Config option S14		4127		
ECA 32 Config option S15		4128		
ECA 32 Config option S16		4129		
ECA 32 Config option S17 Pulse/frequency		4130		
ECA 32 Config option S18 Pulse/frequency		4131		
Controller mode				
Circuit 1 mode		4201	R/W	
Circuit 2 mode		4202	R/W	
Circuit 3 mode		4203	R/W	
Circuit 4 mode		4204	R/W	
Circuit 1 status		4211	R	
Circuit 2 status		4212	R	
Circuit 3 status		4213	R	
Circuit 4 status		4214	R	

ECL Comfort 210 / 296 / 310, communication description

ECL Comfort Parameter	Description	PNU	Access	Scale
Limiter info				
Circuit 1 limiter flags 1		4220		
Circuit 1 limiter flags 2		4221		
Circuit 1 limiter flags 3		4222		
Circuit 1 limiter flags 4		4223		
Circuit 2 limiter flags 1		4224		
Circuit 2 limiter flags 2		4225		
Circuit 2 limiter flags 3		4226		
Circuit 2 limiter flags 4		4227		
Circuit 3 limiter flags 1		4228		
Circuit 3 limiter flags 2		4229		
Circuit 3 limiter flags 3		4230		
Circuit 3 limiter flags 4		4231		
Circuit 4 limiter flags 1		4232		
Circuit 4 limiter flags 2		4233		
Circuit 4 limiter flags 3		4234		
Circuit 4 limiter flags 4		4235		
M-bus				
M-bus - common				
Baud rate		5997		
Command request		5998		
State		5999		
M-bus Energy meter 1				
Address		6000		
Type		6001		
Scan time		6002		
ID / Serial		6003		
- low part		6004		
Reserved		6005		
Flow temperature		6006		
Return temperature		6007		
Flow		6008		
- low part		6009		
Power		6010		
- low part		6011		
Accumulated Volume		6012		
- low part		6013		
Accumulated Energy		6014		
- low part		6015		
Dynamic part		...		
Last pnu		6049		
M-bus Energy meter 2				
..		6050		
M-bus Energy meter 2				
..		6100		
M-bus Energy meter 2				
..		6150		
M-bus Energy meter 2				
..		6200		
Last pnu		6249		
Daylight saving time changeover		10198		

ECL Comfort 210 / 296 / 310, communication description

ECL Comfort Parameter	Description	PNU	Access	Scale
Raw sensor 1		10201		100
Raw sensor 2		10202		100
Raw sensor 3		10203		100
Raw sensor 4		10204		100
Raw sensor 5		10205		100
Raw sensor 6		10206		100
Raw sensor 7		10207		100
Raw sensor 8		10208		100
Raw sensor 9		10209		100
Raw sensor 10		10210		100
Raw sensor 11		10211		100
Raw sensor 12		10212		100
ECA30 room A, Raw sensor 13		10213		100
ECA30 room A res.		10214		
ECA30 room A, humidity, raw sensor 15		10215		
ECA30 room B, Raw sensor 13		10216		
ECA30 room B res.		10217		
ECA30 room B, humidity, raw sensor 15		10218		
ECA32 S13		10219		
ECA32 S14		10220		
ECA32 S15		10221		
ECA32 S16		10222		
ECA32 S17 PF		10223		
ECA32 S18 PF		10224		
Makeup_Number_Of_Pumps	Make up water	10326		
Scada Outdoor temperature		10400		100
Scada heat offset 1		10401		
Scada heat offset 2		10402		
Scada heat offset 3		10403		
Scada heat offset 4		10404		
Scada boiler ctrl 1		10405		
Scada boiler ctrl 2		10406		
Scada boiler ctrl 3		10407		
Scada boiler ctrl 4		10408		
MinOutdoorTemp		10500		
MinHourTime		10501		
MinMinuteTime		10502		
MaxOutdoorTemp		10505		
MaxHourTime		10506		
MaxMinuteTime		10507		
OutdoorTrend		10510		

ECL Comfort 210 / 296 / 310, communication description

ECL Comfort Parameter	Description	PNU	Access	Scale
Alarm group contains 20 PNU's can be placed at 10600, 116x0, 126x0, 136x0				
Pressure		0	10600	
Voltage		1	10601	
Temperature		2	10602	
Digital		3	10603	
-res		4	10604	
-res		5	10605	
-res		6	10606	
Low X		7	10607	
High X		8	10608	
Low Y		9	10609	
High Y		10	10610	
-res		11	10611	
-res		12	10612	
-res		13	10613	
Alarm High		14	10614	
Alarm Low		15	10615	
Digital Alarm value		16	10616	
Timeout		17	10617	
-res		18	10618	
-res		19	10619	
Holiday group number 107xx, 117xx, 127xx, 137xx				
Hol_Status_P1	Holiday program 1		10700	
Hol_Start_Day_P1			10701	
Hol_Start_Month_P1			10702	
Hol_Start_Year_P1			10703	
Hol_End_Day_P1			10704	
Hol_End_Month_P1			10705	
Hol_End_Year_P1			10706	
Hol_Status_P2	Holiday program 2		10707	
			10713	
Hol_Status_P3	Holiday program 3		10714	
			10720	
Hol_Status_P4	Holiday program 4		10721	
			10727	
Hol_Status_P5	Holiday program 5		10728	
			10734	
Hol_Status_P6	Holiday program 6		10735	
			10741	
Hol_Status_P7	Holiday program 7		10742	
			10748	
Hol_Status_P8	Holiday program 8		10749	
			10755	
Hol_Status_P9	Holiday program 9		10756	
			10762	
Hol_Status_P10	Holiday prog. 10		10763	
			10769	
Hol_Status_P11	Holiday prog. 11		10770	
			10776	

ECL Comfort 210 / 296 / 310, communication description

ECL Comfort Parameter	Description	PNU	Access	Scale
Hol_Status_P12	Holiday prog. 12	10777		
		10783		
Hol_Status_P13	Holiday prog. 13	10784		
		10790		
Hol_Status_P14	Holiday prog. 14	10791		
		10797		
Hol_Status_P15	Holiday prog. 15	10798		
		10804		
Hol_Status_P16	Holiday prog. 16	10805		
		10811		
Hol_Status_P17	Holiday prog. 17	10812		
		10818		
Hol_Status_P18	Holiday prog. 18	10819		
		10825		
Hol_Status_P19	Holiday prog. 19	10826		
		10832		
Hol_Status_P20	Holiday prog. 20	10833		
		10839		

ECL Comfort 210 / 296 / 310, communication description

ECL Comfort Parameter	Description	PNU	Access	Scale
ECA addr.		11010		
Auto saving		11011		
Boost		11012		
Ramp		11013		
Optimizer		11014		
Adapt. time		11015		
Master/ slave demand		11017		
Based on		11020		
Total stop		11021		
P exercise		11022		
M exercise		11023		
Actuator		11024		
Pre stop		11026		
Limit		11030		
High T out X1		11031		
Low limit Y1		11032		
Low T out X2		11033		
High limit Y2		11034		
Infl. - max.		11035		10
Infl. - min.		11036		10
Adapt. time		11037		
Heat Circulation postrun		11040		
DHW Primary postun		11041		
DHW Secondary postrun		11042		
Parallel operation		11043		
Max Hot water load time		11044		
Max heat time		11045		

ECL Comfort 210 / 296 / 310, communication description

ECL Comfort Parameter	Description	PNU	Access	Scale
Master/slave Pump demand		11050		
Valve or pump function		11051		
DHW prior.		11052		
Primary secondary placed		11053		
Continue regulation		11054		
DHW Circulation Priority		11055		
Wind_Gain_Min		11056		
Wind_Gain_Max		11057		
Flow T adapt time		11067		
Flow_Switch		11069		
Circulation P frost T		11076		
P frost T		11077		
P heat T		11078		
Max. FlowTemp.		11079		
Delay		11080		
Wind Filter const.		11081		
External_Setpoint		11084		
Priority		11085		
Standby T (Cool application)		11092		
Frost pr. T (Heat application)		11093		
Start_Puls		11094		
Stop_Puls		11095		
PI_Tn_Saving		11096		
Sensor_Saving		11097		
Wind speed		11098		
Wind_Setpoint		11099		
S1 T filter		11100		
Ext. desired		11101		
Flow_Energy_Input_Type		11109		
Flow_Energy_actual		11110		10
Flow_Energy_Limit		11111		10
Flow_Energy_Intr.gr		11112		
Flow_Energy_Filter_Value		11113		
Flow_Energy_Impuls		11114		
Flow_Energy_Unit		11115		
Flow_Energy_High_Limit_Y2		11116		10
Flow_Energy_Low_Limit_Y1		11117		10
Flow_Energy_Low_Tout_X2		11118		
Flow_Energy_High_Tout_X1		11119		

ECL Comfort 210 / 296 / 310, communication description

ECL Comfort Parameter	Description	PNU	Access	Scale
Ext. input		11141		
Ext. mode		11142		
Alarm Clear		11146		
Upper difference		11147		
Lower difference		11148		
Delay		11149		
Cut off temp.		11150		
Max DHW load temperature		11152		
Knee point		11162		
Motor pr.		11174		
Heat curve ⁸		11175		10
Displace		11176		
Temp. min.		11177		
Temp. max.		11178		
Cut-out		11179		
Comfort Room setpoint		11180		10
Saving Room setpoint		11181		10
Infl. - max.		11182		
Infl. - min.		11183		10
Xp		11184		10
Tn		11185		
M run		11186		
Nz		11187		
Min. act. time		11189		
Comfort DHW setpoint		11190		10
Saving DHW setpoint		11191		10
Circuit 1 sensor values⁹				
S1 sensor		11201	R	100
S2 sensor		11202	R	100
S3 sensor		11203	R	100
S4 sensor		11204	R	100
S5 sensor		11205	R	100
S6 sensor		11206	R	100
S7 sensor		11207	R	100
S8 sensor		11208	R	100
S9 sensor		11209	R	100
S10 sensor		11210	R	100
S1 sensor reference		11251	R	100
S2 sensor reference		11252	R	100
S3 sensor reference		11253	R	100
S4 sensor reference		11254	R	100
S5 sensor reference		11255	R	100
S6 sensor reference		11256	R	100
S7 sensor reference		11257	R	100
S8 sensor reference		11258	R	100
S9 sensor reference		11259	R	100
S10 sensor reference		11260	R	100

⁸ In some applications the heat curve parameter is writable, and will, if set, adjust “y” points (PNU 11400 – 11405)!

⁹ Sensors within a circuit (e.g. 11202, 12202, not 10202) are normally only available for sensors that have multiple sources e.g. room temperature that also can come from ECA 30

ECL Comfort 210 / 296 / 310, communication description

ECL Comfort Parameter	Description	PNU	Access	Scale
High_Signal_X2		11300		
High_Setpoint_Y2		11301		
Low_Signal_X1		11302		
Low_Setpoint_Y1		11303		
Retry Time	Two pump control	11310		
TP_Day_Value	Two pump control	11311		
TP_Hour_Value	Two pump control	11312		
Stabilization Time	Two pump control	11313		
ChangeOver Time	Two pump control	11314		
Alarm_Status_Clear_TwinPump	Two pump control	11315		
TwinPump_Motion	Two pump control	11316		
Makeup_Motion	Make up water	11320		
Makeup_Pressure_Set	Make up water	11321		
Makeup_Pressure_Diff	Make up water	11322		
Makeup_Time_Out	Make up water	11323		
Alarm_Status_Clear_Makeup	Make up water	11324		
Wait_Open_Valve	Make up water	11325		
Makeup_Number_Of_Pumps	Make up water	11326		
Makeup_Input_Type	Make up water	11327		
H-Curve point Y1		11400		
H-Curve point Y2		11401		
H-Curve point Y3		11402		
H-Curve point Y4		11403		
H-Curve point Y5		11404		
H-Curve point Y6		11405		
H-Curve point X1 ¹⁰		11406		
H-Curve point X2		11407		
H-Curve point X3		11408		
H-Curve point X4		11409		
H-Curve point X5		11410		
H-Curve point X6		11411		
Select reference		11500		
Reference place		11501		
Pressure		11600		
Alarm high		11614		
Alarm low		11615		
Alarm timeout		11617		
Low X		11607		
High X		11608		
Low Y		11609		
High Y		11610		
Digital		11623		

¹⁰ The heat curve X points are typical not available

ECL Comfort 210 / 296 / 310, communication description

ECL Comfort Parameter	Description	PNU	Access	Scale
Alarm value		11636		
Alarm timeout		11637		
Display backlight		60058		
Display contrast		60059		
Hour		64045	R/W	
Min		64046	R/W	
Date		64047	R/W	
Month		64048	R/W	
Year		64049	R/W	

9.6 Revision History

Version	Date	Description
1	2010-11-15	Initial release
2	2011-03-21	Minor corrections
3	2011-08-20	Correction to schedule description and minor additions
4	?	Addition to Holiday description Added description of output (such as ECA 32 relays and analogue outputs) Parameter List updated, scale Added better description about schedules and anti-bacteria and for extra circuits

Danfoss A/S

Heating Segment • heating.danfoss.com • +45 7488 2222 • E-Mail: heating@danfoss.com

Danfoss can accept no responsibility for possible errors in catalogues, brochures and other printed material. Danfoss reserves the right to alter its products without notice. This also applies to products already on order provided that such alterations can be made without subsequential changes being necessary in specifications already agreed.
All trademarks in this material are property of the respective companies. Danfoss and all Danfoss logotypes are trademarks of Danfoss A/S. All rights reserved.
