

Инструкция

VG, VGF, VGS, VGU, VGUF

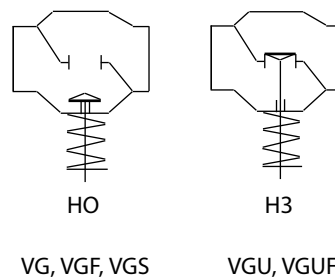

Тип	P _y	T _{макс.} (°C)	T _{мин.} (°C)
VG	25	150	2
VGF	25	150	2
VGS	25	200	2
VGU	25	150	2
VGUF	25	150	2

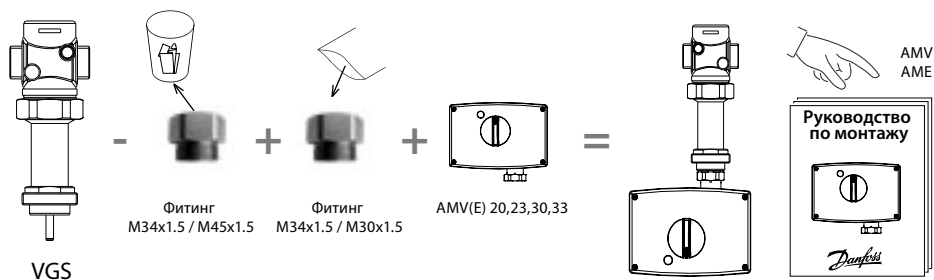
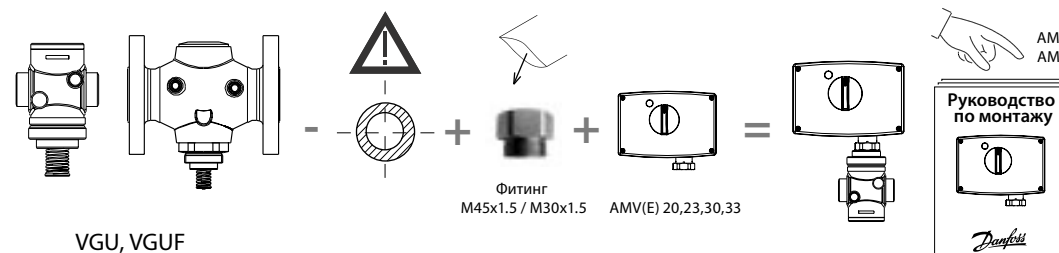
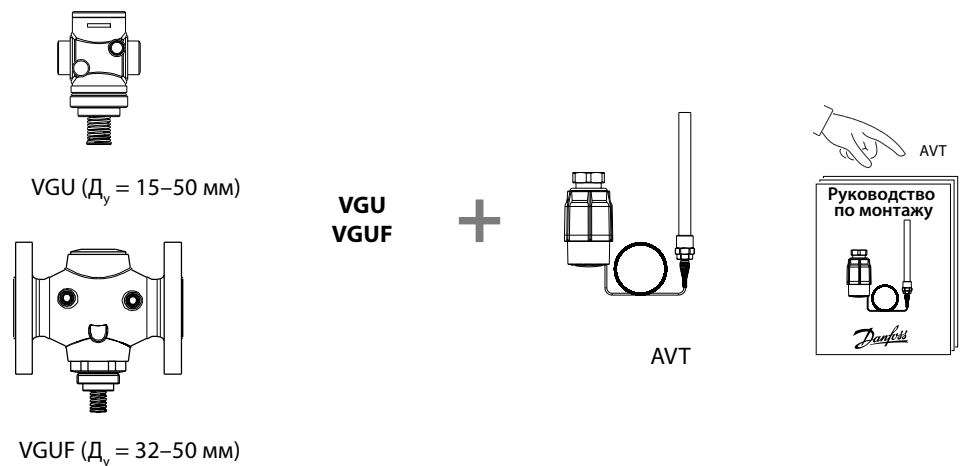
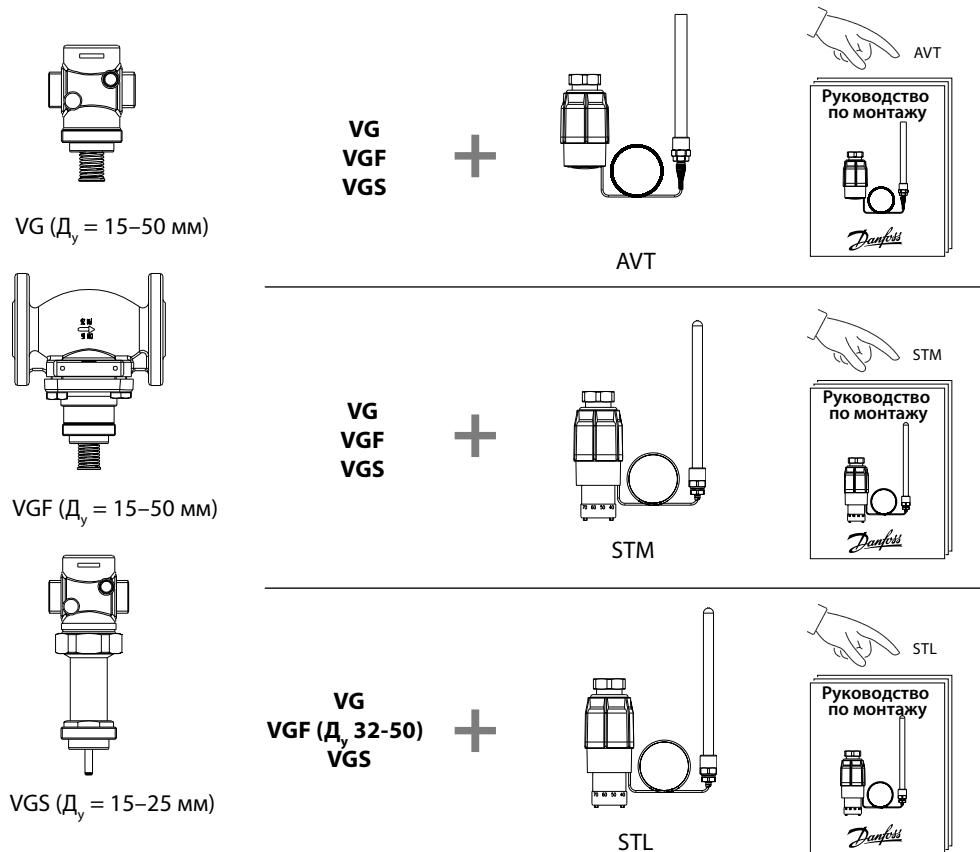
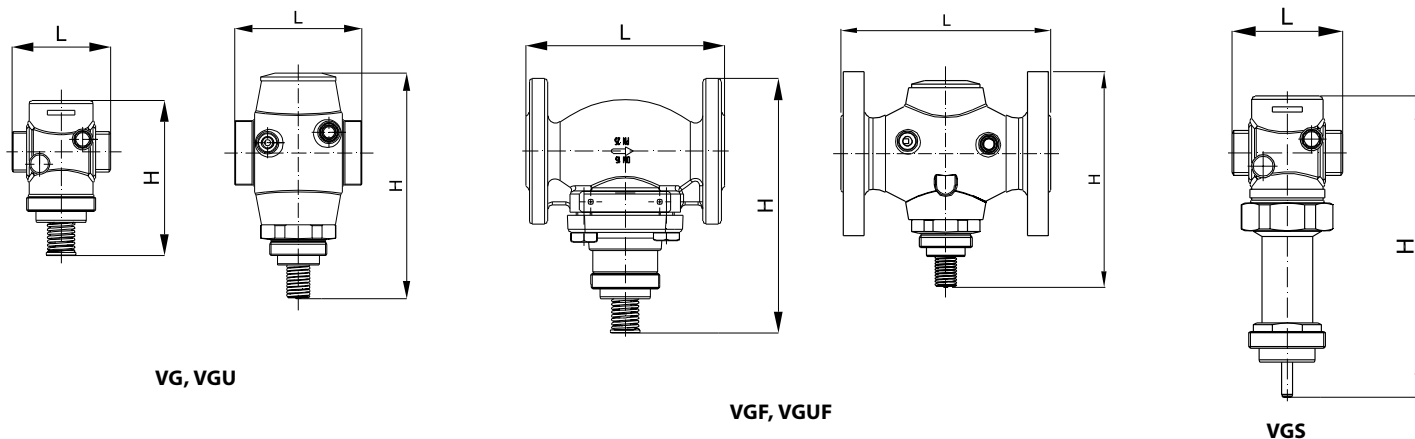

D _в , мм		15	20	25	32	40	50
VG	L	65	70	75	100	110	130
	H	102	102	102	176	176	176
VGF	L	130	150	160	180	200	230
	H	165	172	175	184	189	196
VGS	L	65	70	75	-	-	-
	H	176	176	179	-	-	-
VGU	L	65	70	75	100	110	130
	H	105	105	107	173	173	173
VGUF	L	-	-	-	180	200	230
	H	-	-	-	180	185	193

Примечание: другие размеры фланцев — смотри таблицу для фитингов.

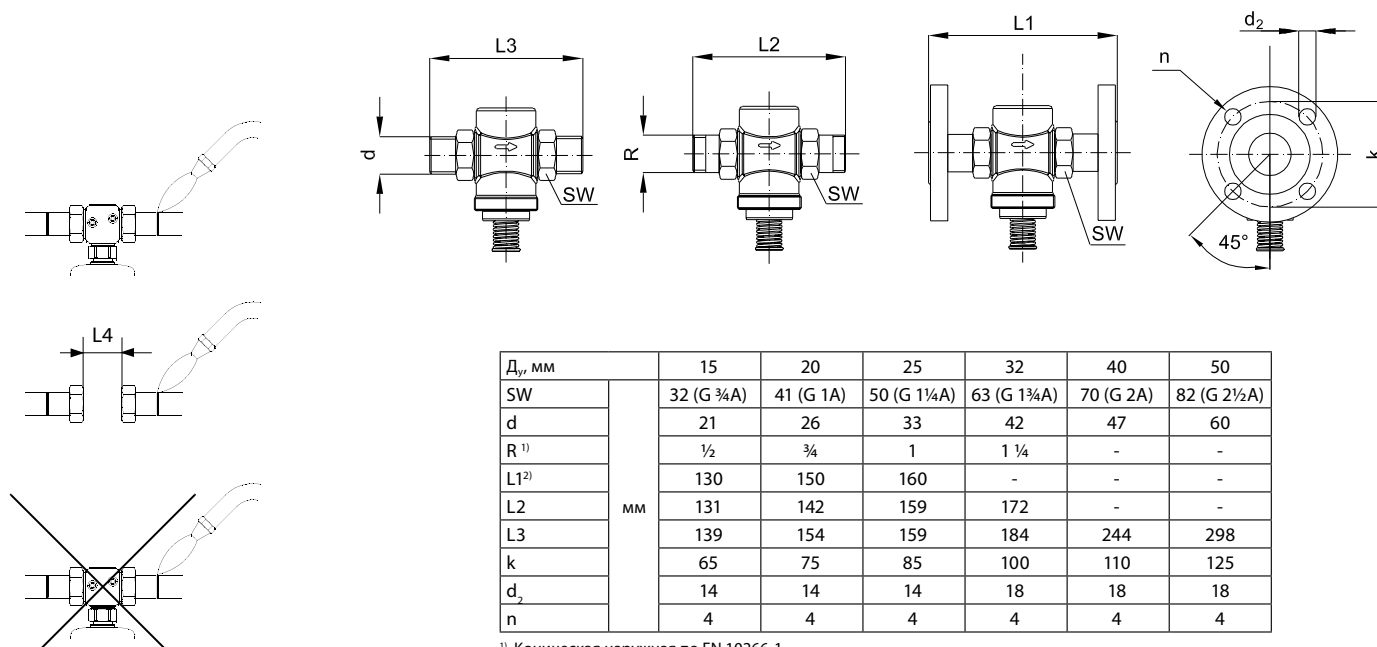

¹⁾ Коническая наружная по EN 10266-1.

²⁾ Фланцы P_g 25, по EN 1092-2.

В соответствии с EN 1092-2, EN 1092-3

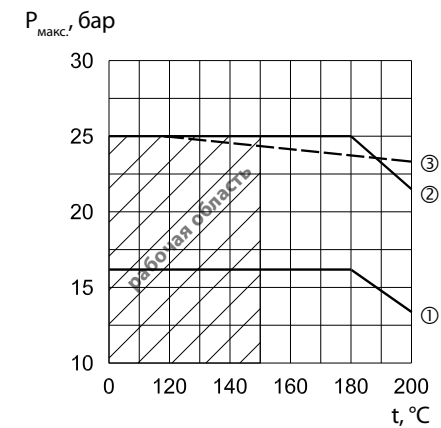

① CuSn5ZnPb (Rg5) P_y 16

② CuSn5ZnPb (Rg5) P_y 25

③ EN-GJS-400-18-LT (GGG 40.3) P_y 25