

Operation guide

# Rotary position sensors CANopen output DST X510 and DST X520



**Table of contents**

Contents	
1. General information.....	2
1.1 Contact.....	2
1.2 General.....	2
1.3 Abbreviations.....	3
2. Electrical connections.....	4
2.1 Deutsch version with shaft.....	4
2.2 AMP Supersxeal with shaft.....	5
2.3 AMP Superseal without shaft.....	6
2.4 Cable without shaft.....	7
2.5 Functional Block.....	8
3. Network Management.....	8
4. Baud rate.....	9
5. Node-ID and Resolution.....	9
6. Parameter settings.....	9
7. Restore default parameters.....	10
8. Restore default parameters.....	10
9. Error handling.....	10
10. SDO communication.....	11
11. PDO communication and Angle calculation.....	11
12. CANopen features summary.....	15
13. Communication examples.....	19

---

**1. General Information****1.1 Contact**

Danfoss A/S  
Industrial Automation  
DK-6430 Nordborg  
Denmark  
[www.ia.danfoss.com](http://www.ia.danfoss.com)  
E-mail: [IA-Sensorglobaltechnicalsupport@danfoss.com](mailto:IA-Sensorglobaltechnicalsupport@danfoss.com)

---

**1.2 General**

The document describes the standard CANopen implementations created. It is addressed to CANopen system integrators and to CANopen device designers who already know the content of standards designed by C.i.A. (CAN in Automation).

### 1.3 Abbreviations and terms

Abbreviation/term	Definition
CAN	Controller Area Network Describes a serial communication bus that implements the “physical” level 1 and the “data link” level 2 of the ISO/OSI reference model.
CAN	CAN Application Layer Describes implementation of the CAN in level 7 “application” of the ISO/OSI reference model from which CANopen derives.
CMS	CAN Message Specification CAN service element. Defines the CAN Application Layer for the various industrial applications.
COB	Communication Object Unit of transport of data in a CAN network (aCAN message). A maximum of 2,048 COBs may be present in a CAN network, each of which may transport from 0 to a maximum of 8 bytes.
COB-ID	COB Identifier Identifying element of a CAN message. The identifier determines the priority of a COB in case of multiple messages in the network.
D1 - D8	Data from 1 to 8 Number of data bytes in the data field of a CAN message.
DLC	Data Length Code Number of data bytes transmitted in a single frame.
ISO	International Standard Organization International authority providing standards for various merchandise sectors.
NMT	Network Management CAN service element. Describes how to configure, initialize, manage errors in a CAN network.
PDO	Process Data Object Process data communication objects (with high priority).
RXSDO	Receive SDO SDO objects received from the remote device.
SDO	Service Data Object Service data communication objects (with low priority). The value of this data is contained in the “Objects Dictionary” of each device in the CAN network.
TXPDO	Transmit PDO PDO objects transmitted by the remote device.
TXSDO	Transmit SDO SDO objects transmitted by the remote device.

**NOTE:**

The numbers followed by the suffix “h” represent a hexadecimal value, with suffix “b” a binary value, and with suffix “d” a decimal value. The value is decimal unless specified otherwise.

2. Electrical Connections    2.1 Deutsch version with shaft

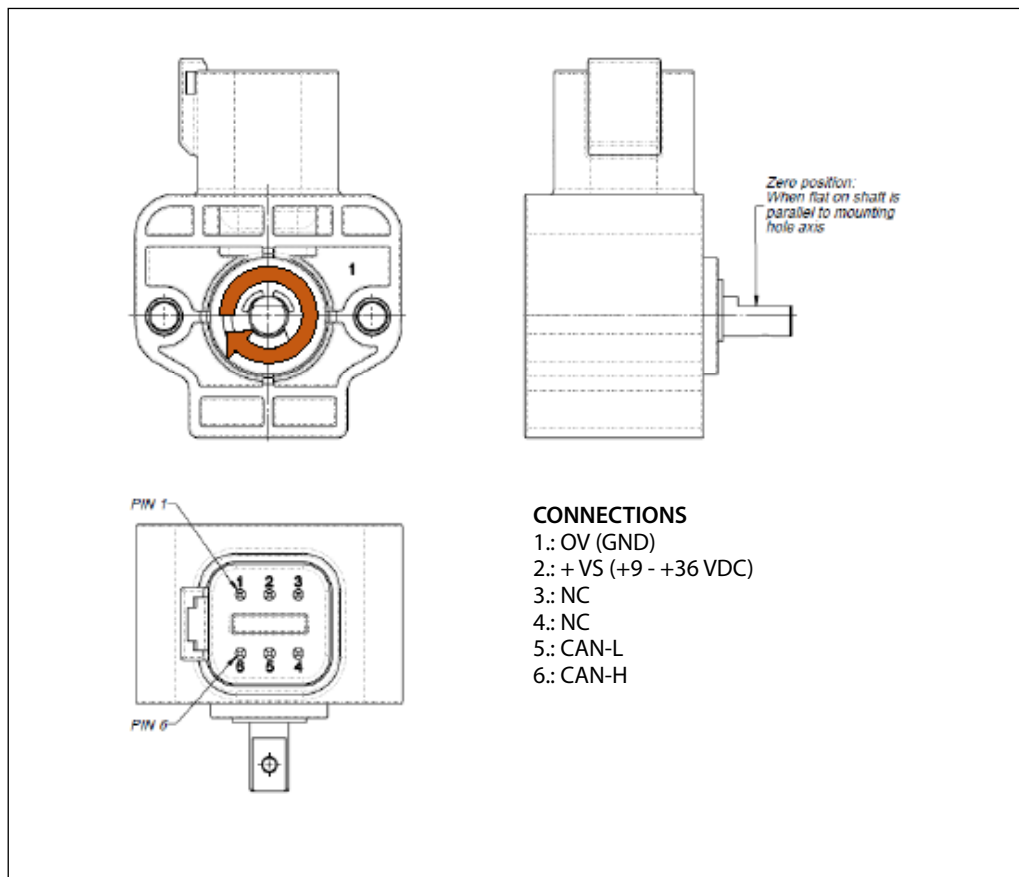

**NOTE:**

Please make sure that the CANbus is terminated. The impedance measured between CAN-H and CAN-L must be 60 ohm that means the cable must be connected to a 120 ohm resistor on each ends of the bus line. Internally the transducer is not terminated with the resistor of 120 ohm. Do not confuse the signal lines of the CAN bus, otherwise communication with the transducer is impossible.

## 2.2 AMP version with shaft

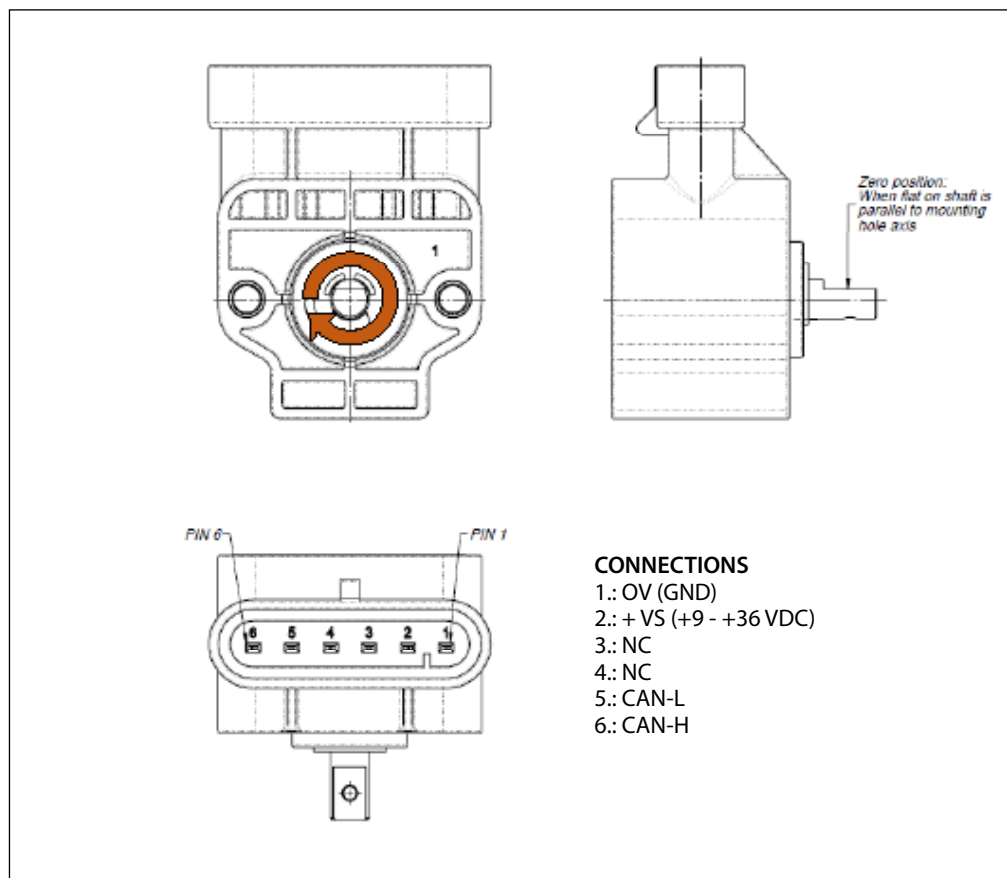

### NOTE:

Please make sure that the CANbus is terminated. The impedance measured between CAN-H and CAN-L must be 60 ohm that means the cable must be connected to a 120 ohm resistor on each ends of the bus line. Internally the transducer is not terminated with the resistor of 120 ohm. Do not confuse the signal lines of the CAN bus, otherwise communication with the transducer is impossible.

### 2.3 AMP Superseal version without shaft

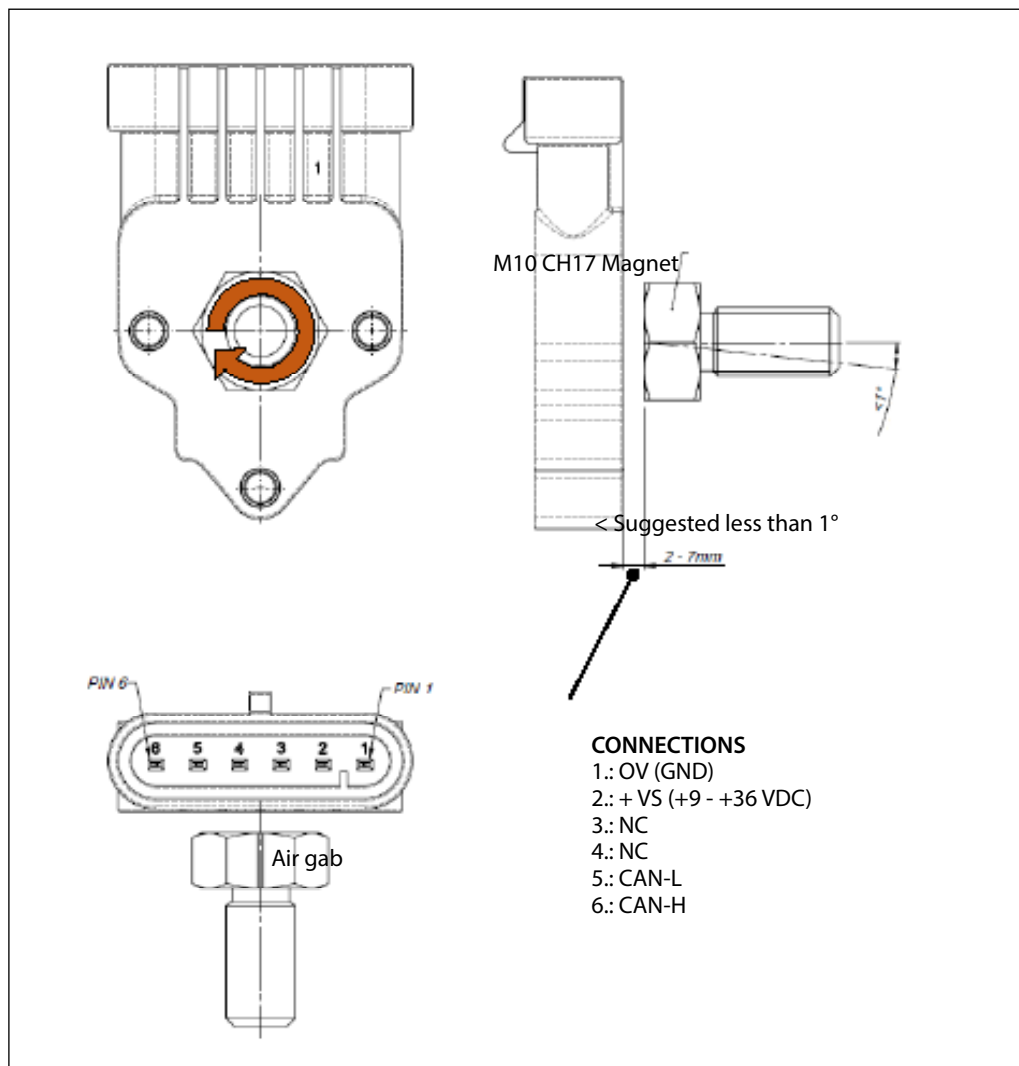

**NOTE:**

Please make sure that the CANbus is terminated. The impedance measured between CAN-H and CAN-L must be 60 ohm that means the cable must be connected to a 120 ohm resistor on each ends of the bus line. Internally the transducer is not terminated with the resistor of 120 ohm. Do not confuse the signal lines of the CAN bus, otherwise communication with the transducer is impossible.

## 2.4 Cable version without shaft

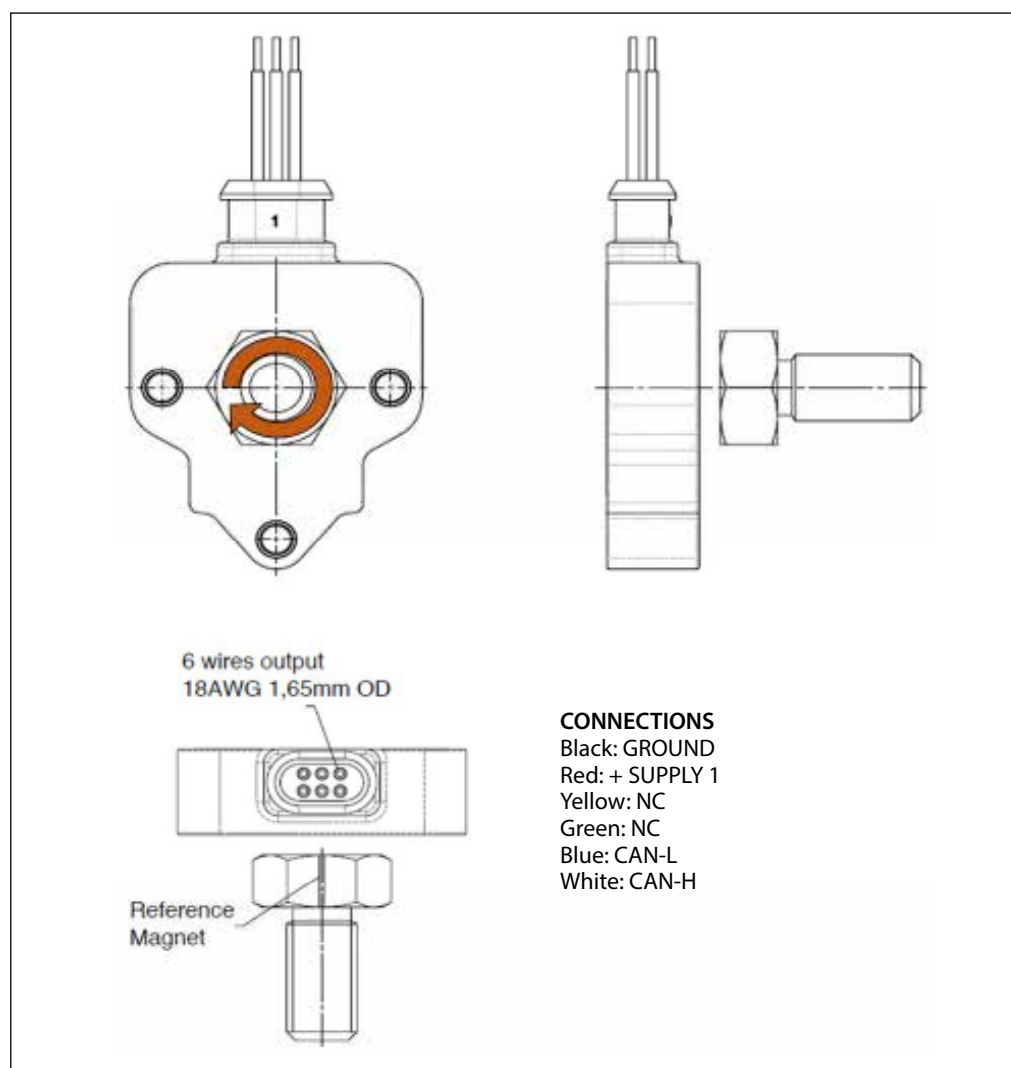

### NOTE:

Make sure that the CANbus is terminated. The impedance measured between CAN-H and CAN-L must be 60 ohm that means the cable must be connected to a 120 ohm resistor on each end of the bus line. Internally the transducer is not terminated with resistor of 120 ohm. Do not confuse the signal lines of the CANbus, otherwise communication with the transducer is impossible.

### 2.5 Functional Block

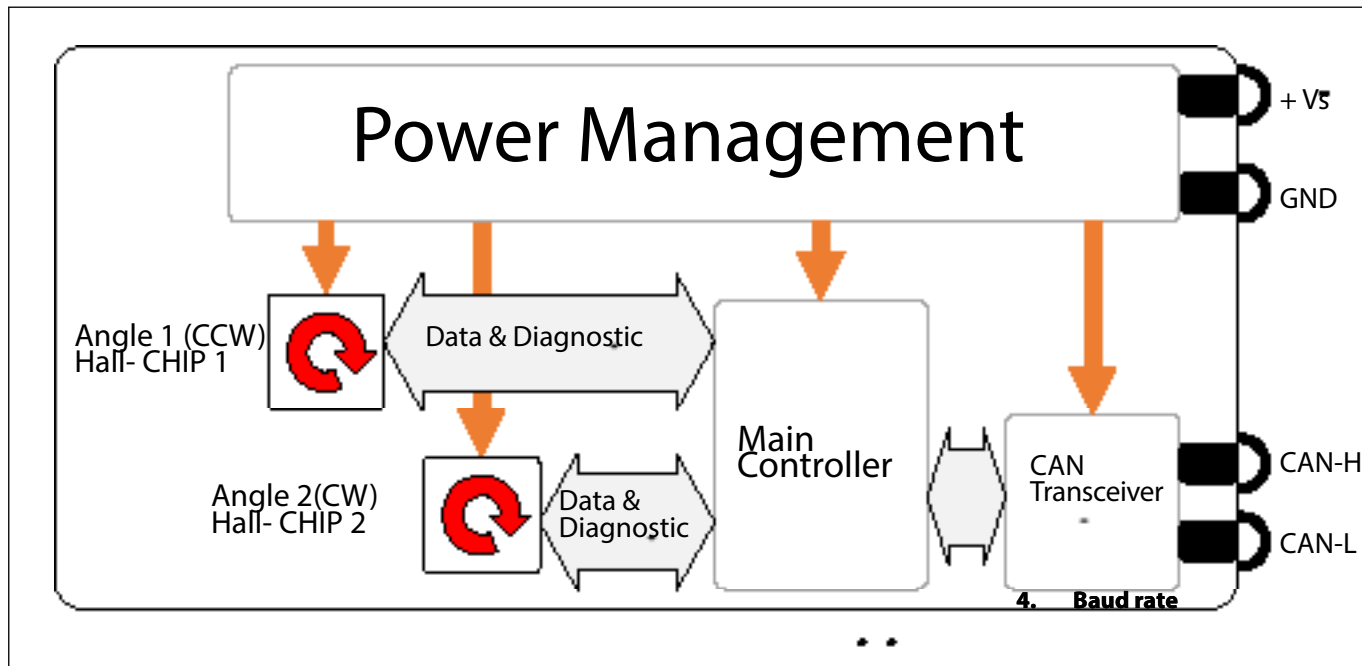

3. **Network Management (NMT)** The device supports CANopen network management functionality NMT Slave (Minimum Boot Up).

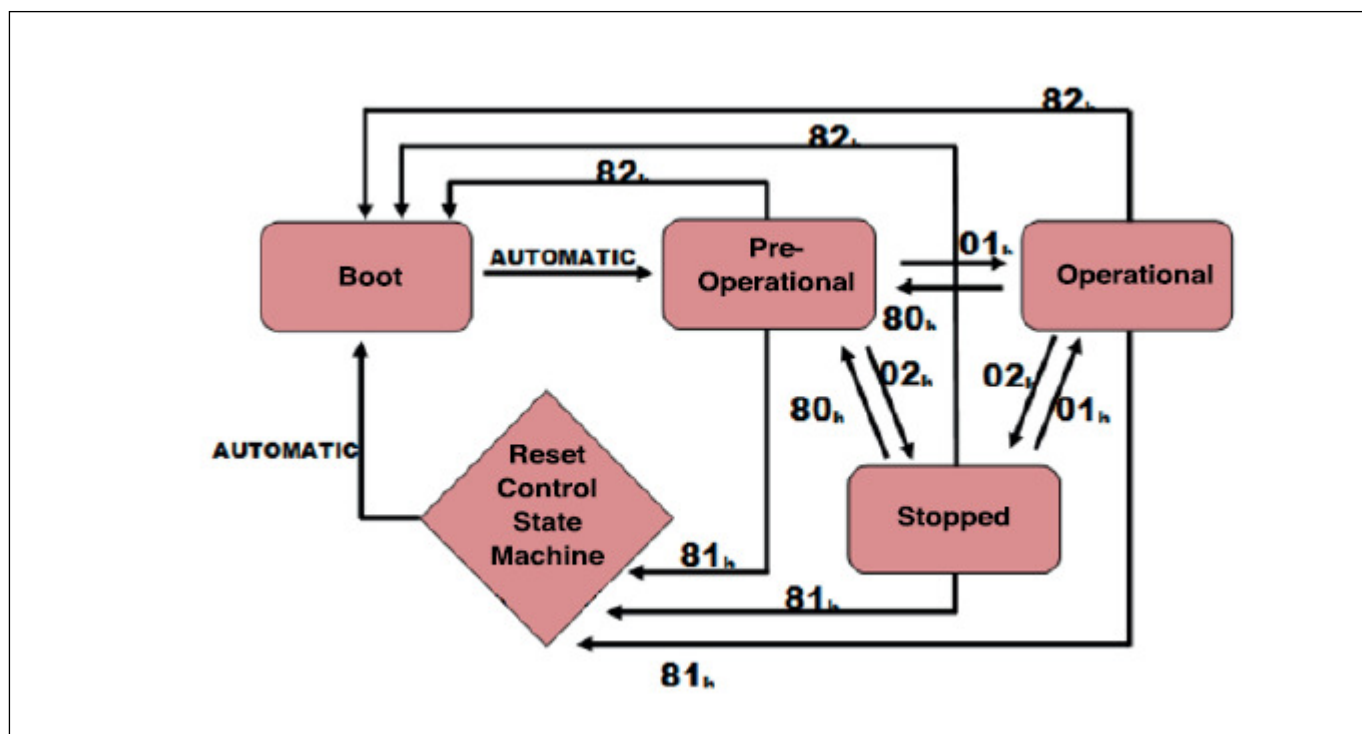



Every CANopen device contains an international Network Management server that communicates with an external NMT master. One device in a network, generally the host, may act as the NMT master.

Through NMT messages, each CANopen device's network management server controls state changes within its built-in **Communication State Machine**.

This is independent from each node's operational state machine, which is device dependant and described in **Control State Machine**.

It is important to distinguish a CANopen device's operational state machine from its Communication State Machine. CANopen sensors and I/O modules, for example, have completely different operational state machines than servo drives. The **"Communication State Machine"** in all CANopen devices, however, is identical as specified by the DS301.

NMT messages have the highest priority. The 5 NMT messages that control the Communication State Machine each contain 2 data bytes that identify the node number and a command to that node's state machine.

Table 1 shows the 5 NMT messages supported, and Table 2 shows the correct message for sending these messages.

NMT Message	COOB-ID	Data Byte 1	Data Byte 2
Start Remote Node	0	01h	Node-ID*
Stop Remote Node	0	02h	Node-ID*
Pre-operational State	0	80h	Node-ID*
Reset Node	0	81h	Node-ID*
Reset Communication	0	82h	Node-ID*
* Node-ID = Drive address (from 1 to 7Fh)			

Table 1

Arbitration Field	Data Field										
	COB-ID	RTR	Byte 1	Byte 2	Byte 3	Byte 4	Byte 5	Byte 6	Byte 7	Byte 8	
000h	0	See table 1	See table 2	These bytes are not sent							

Table 2

#### 4. Baud rate

Baud rate can be configurable via Layer Setting Services and Protocol (LSS) and via SDO communication (index 0x5999).

**The default Baud rate is 250kbit/s.**

#### Important Note:

*Changing this parameter can disturb the network!  
Use the service only if one device is connected to the network!*

#### 5. Baud rate

Node-ID can be configurable via Layer Setting Services and Protocol (LSS) and via SDO communication (index 0x5999).

This parameters are called LSS parameters (marking LSS-PARA). The resolution can be configurable by using manufacturing specific objec 0x2100.

**The default Node-ID is 7F.  
The default resolution is 0.1°.**

#### Important note:

*Changing this parameter can disturb the network!  
Use the service only if one device is connected to the network!*

#### 6. Parameter settings

All object dictionary parameters (object with marking PARA) can be saved in a special section of the internal EEPROM and secured by checksum calculation.

The special LSS parameters (objects with marking LL-PARA), also part of the object dictionary, will be also saved in a special section of the internal EEPROM and secured by checksum calculation.

Due to the internal architecture of the microcontroller the parameter write cycles are limited to 100,000 cycles.

- 7. Restore default parameters**
- All object dictionary parameters (objects with marking PARA) can be restored to factory default values via SDO communication (index 0x1011).

**8. Restore default parameters**

The heartbeat mechanism for this device is established through cyclic transmission of the heartbeat message done by the heartbeat producer. One or more devices in the network are aware of this heartbeat message. If the heartbeat cycle fails from the heartbeat producer the local application on the heartbeat consumer will be informed about that event.

The implementation of either guarding or heartbeat is mandatory. The device supports Heartbeat Producer functionality. The producer heartbeat time is defined in object 0x1017.

**Heartbeat Message**

COB-ID	Byte	0
700 + Node-ID	Content	NMT State

**9. Error handling**

**Principle**

Emergency messages (EMCY) shall be triggered by internal errors on device and they are assigned the highest possible priority to ensure that they get access to the bus without delay (EMCY Producer). By default, the EMCY contains the error field with pre-defined error numbers and additional information.

**EMCY Message**

The EMCY COB-ID is defined in object 0x1014. The EMCY message consists of 8 bytes. It contains an emergency error code, the contents of object 0x1001 and 5 byte of manufacturer specific error code. The device uses only the 1st byte as manufacturer specific error code. When a failure occurs, the reading of the angular position from the failed channel presents an out-of-range value, i.e. 0xFFFF.

**Error Behavior (object 0x4000)**

If a serious device failure is detected the object 0x4000 specifies, to which state the module shall be set:

- =: Pre-operational
- 1: No state change (default)
- 2: Stopped

**Supported Manufacturer Specific Error Codes (object 0x4001)**

Error code	Description
0000 0000	No error
0000 0001	Angle 1 sensor chip error
0000 0010	Angle 2 sensor chip error
0000 0100	Angle mismatch (Angle 1 vs Angle 2) error, object 0x2103 <b>NOT IMPLEMENTED</b>
0001 0000	Program checksum error
0100 0000	LSS Parameter checksum error
1000 0000	Magnetic field too high/low

## 10. SDO communication

The device fulfils the SDO Server functionality. With Service Data Object (S.D.O.) the access to entries of a device Object Dictionary is provided. As these entries may contain data of arbitrary size and data type SDOs can be used to transfer multiple data sets from a client to a server and vice versa.

### Structure of SDO-request by the Master

COB-ID	DLC	Byte 1	Byte 2	Byte 3	Byte 4	Byte 5	Byte 6	Byte 7	Byte 8
600+Node-ID	8	CMD	Index		Sub-Index	Data	Data	Data	Data

### Structure of SDO-answer by the Slave

COB-ID	DLC	Byte 1	Byte 2	Byte 3	Byte 4	Byte 5	Byte 6	Byte 7	Byte 8
5807+Node-ID	8	RES	Index		Sub-Index	Data	Data	Data	Data

#### Write Access, Data Transfer from Host to Slave

Each access to object dictionary is checked by the slave for validity. Any write access to nonexistent objects, to read - only objects or with a non-corresponding data format are rejected and answered with a corresponding error message.

*CMD determines the direction of data transfer and the size of the data object:*

23 hex Sending of 4-byte data  
(bytes 5 - 8 contain a 32-bit value)  
2B hex Sending of 2-byte data  
(bytes 5, 6 contain a 16-bit value)  
2F hex Sending of 1-byte data  
(byte 5 contains an 8-bit value)

*The Slave answers:*

RES response of the slave:  
60 hex Data sent successfully  
80 hex Error

#### Read Access, Data Transfer from Slave to Host

Any read access to non-existing objects is answered with an error message.

*CMD determines the direction of data transfer:*  
40 hex read access (in any case)

*The Slave answers:*

RES Response of the slave:  
42 hex Bytes used by node when replying to read command with 4 or less data  
43 hex Bytes 5 - 8 contain a 32-bit value  
4B hex Bytes 5, 6 contain a 16-bit value  
4F hex Byte 5 contains an 8-bit value  
80 hex Error

## 11. PDO communication and Angle calculation

### Transmit PDO #0

This PDO transmits asynchronously the position value of the angle sensor. Default transmission rate is 100 ms. The Tx PDO#0 shall be transmitted cyclically, if the cyclic timer (object 0x1800.5) is programmed > 0. Values between 1 ms and 65535 ms shall be selectable by parameter settings. The Tx PDO#0 will be transmitted by entering the "Operational" state.

Byte	Byte 1	Byte 2	Byte 3	Byte 4	Byte 5 Byte 6 Byte 7	Byte 8
Description	ANGLE 1 object (0x2110.1) High-Byte	ANGLE 1 object (0x2110.2) Low-Byte	ANGLE 2 object (0x2110.3) High-Byte	ANGLE 2 object (0x2110.4) Low-Byte	(0xFF)	Error Code (object 0x4001)
TxPDO# with default mapping when object 0x5001 = 0 (big endian)						

Byte	Byte 1	Byte 2	Byte 3	Byte 4	Byte 5 Byte 6 Byte 7	Byte 8
Description	ANGLE 1 object (0x2110.1) Low-Byte	ANGLE 1 object (0x2110.2) High-Byte	ANGLE 2 object (0x2110.3) Low-Byte	ANGLE 2 object (0x2110.4) High-Byte	(0xFF)	Error Code (object 0x4001)
TxPDO# with default mapping when object 0x5001 = 0 (little endian)						

Example of PDO mapping is reported in the case of Angle 1 = 0.00° and Angle 2 = 359.99°

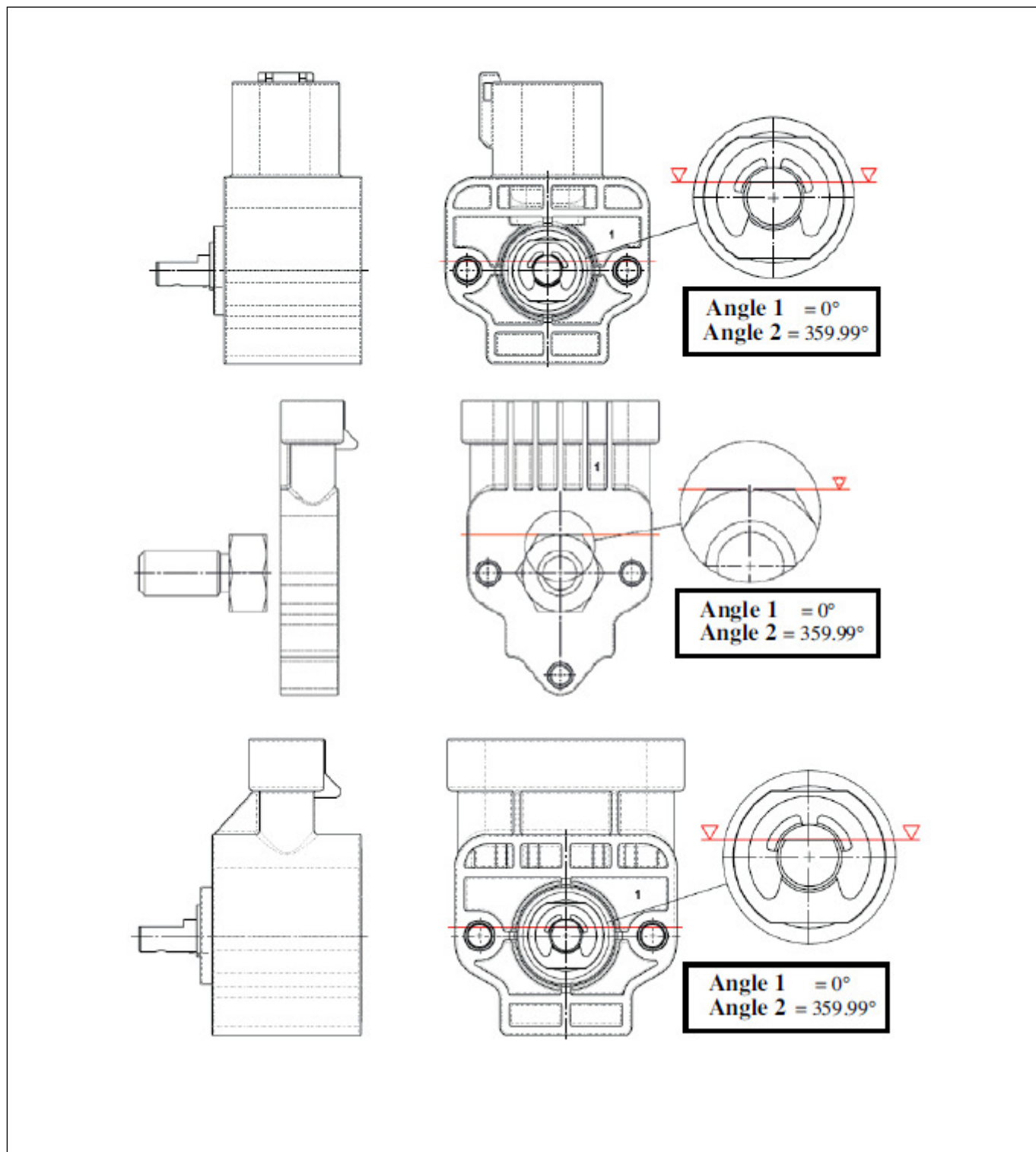

**Reading resolution  $\pm 0.1^\circ$  (see manufacturing specific object 0x2100 and example (7) at the end of this manual)**

Example of PDO mapping for:  
 Angle 1 = 0.-0° and Angle 2 = 359.9° (Node-ID = 02h, resolution 0.1°, zero degree point = 0.0°, CCW and big endian)

ID	Byte 1	Byte 2	Byte 3	Byte 4	Byte 5	Byte 6	Byte 7	Byte 8
182h	00h	00h	0Eh	0Fh	FFh	FFh	FFh	00h

**Angle 1:**

Byte 1 MSB (00h) = 00h Byte 2 LSB (00h) = 00h  
 Angle 1 = 0000h to decimal 0d (resolution 0.1°) = 0.0°

**Angle 2:**

Byte 3 MSB (00h) = 0Eh Byte 4 LSB (00h) = 0Fh  
 Angle 2 = 0E0Fh to decimal 3599d (resolution 0.1°) = 359.9°

**Reading resolution  $\pm 0.01^\circ$  (see manufacturing specific object 0x2100 and example (8) at the end of this manual)**

Example of PDO mapping for:  
 Angle 1 = 0.-0° and Angle 2 = 359.9° (Node-ID = 02h, resolution 0.1°, zero degree point = 0.0°, CCW and big endian)

ID	Byte 1	Byte 2	Byte 3	Byte 4	Byte 5	Byte 6	Byte 7	Byte 8
182h	00h	00h	8Ch	9Fh	FFh	FFh	FFh	00h

**Angle 1:**

Byte 1 MSB (00h) = 00h Byte 2 LSB (00h) = 00h  
 Angle 1 = 0000h to decimal 0d (resolution 0.1°) = 0.0°

**Angle 2:**

Byte 3 MSB (00h) = 0Ch Byte 4 LSB (00h) = 9Fh  
 Angle 2 = 8C9Fh to decimal 35999d (resolution 0.1°) = 359.9°

Example of PDO mapping is reported in the case of Angle 1 = 270.0° and Angle 2 = 90.0°

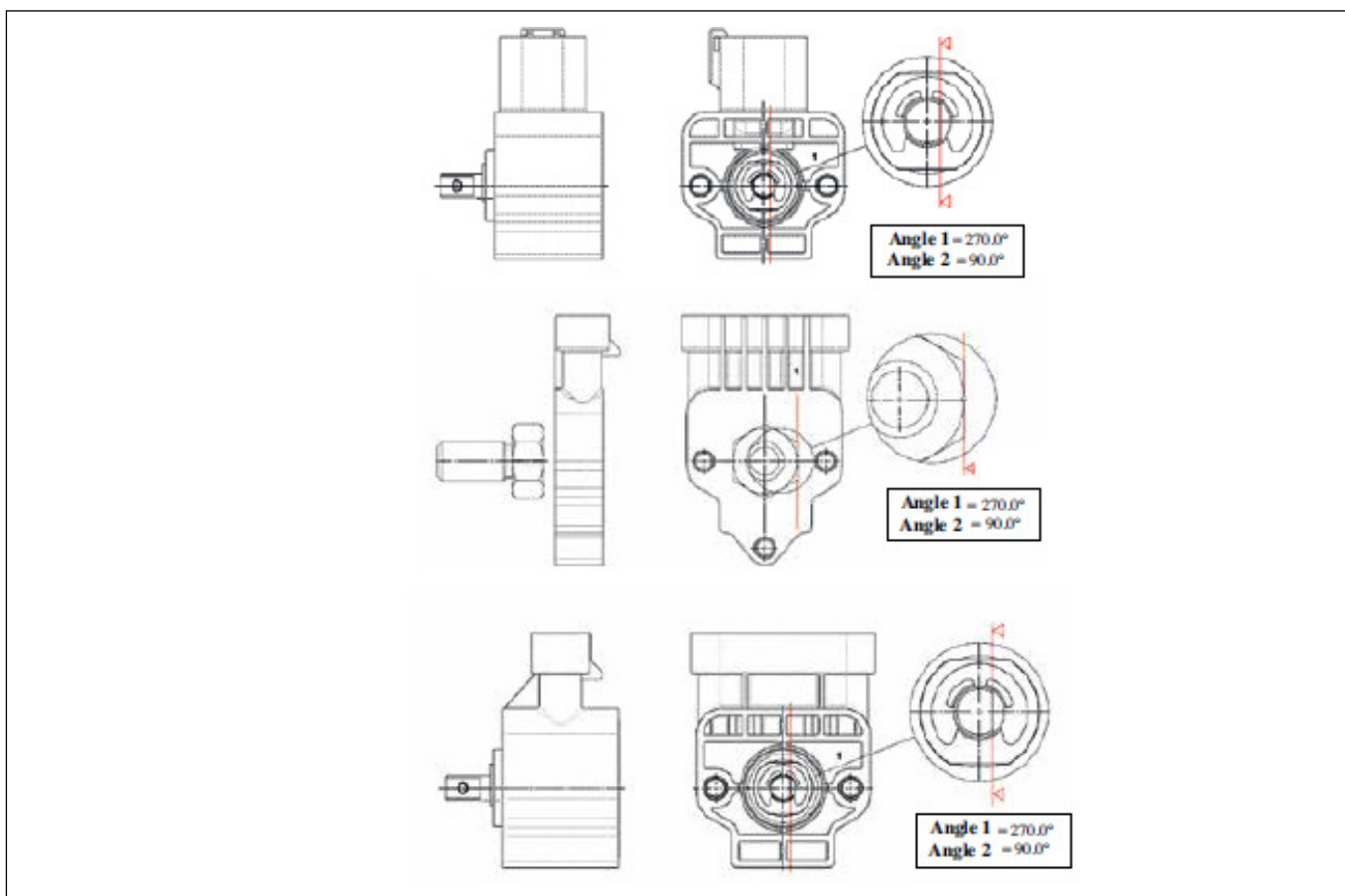

**Reading resolution  $\pm 0.1^\circ$  (see manufacturing specific object 0x2100 and example (7) at the end of this manual)**

Example of PDO mapping for:  
 Angle 1 = 270.-0° and Angle 2 = 90.0° (Node-ID = 02h, resolution 0.1°, zero degree point = 0.0°, CCW and big endian)

ID	Byte 1	Byte 2	Byte 3	Byte 4	Byte 5	Byte 6	Byte 7	Byte 8
182h	0Ah	8Ch	03h	84h	FFh	FFh	FFh	00h

**Angle 1:**  
 Byte 1 MSB (00h) = 0Ah Byte 2 LSB (00h) = 8Ch  
 Angle 1 = 0A8Ch to decimal 0d (resolution 0.1°) = 270.0°

**Angle 2:**  
 Byte 3 MSB (00h) = 03h Byte 4 LSB (00h) = 84h  
 Angle 2 = 0384h to decimal 900d (resolution 0.1°) = 90.0°

**Reading resolution  $\pm 0.01^\circ$  (see manufacturing specific object 0x2100 and example (8) at the end of this manual)**

Example of PDO mapping for:  
 Angle 1 = 270.-0° and Angle 2 = 90.0° (Node-ID = 02h, resolution 0.1°, zero degree point = 0.0°, CCW and big endian)

ID	Byte 1	Byte 2	Byte 3	Byte 4	Byte 5	Byte 6	Byte 7	Byte 8
182h	69h	78h	23h	28h	FFh	FFh	FFh	00h

**Angle 1:**  
 Byte 1 MSB (00h) = 69h Byte 2 LSB (00h) = 78h  
 Angle 1 = 6978h to decimal 27000d (resolution 0.1°) 270.0°

**Angle 2:**  
 Byte 3 MSB (00h) = 23h Byte 4 LSB (00h) = 28h  
 Angle 2 = 90.0°

**Angle calculation for ANGLE 1 and ANGLE 2**

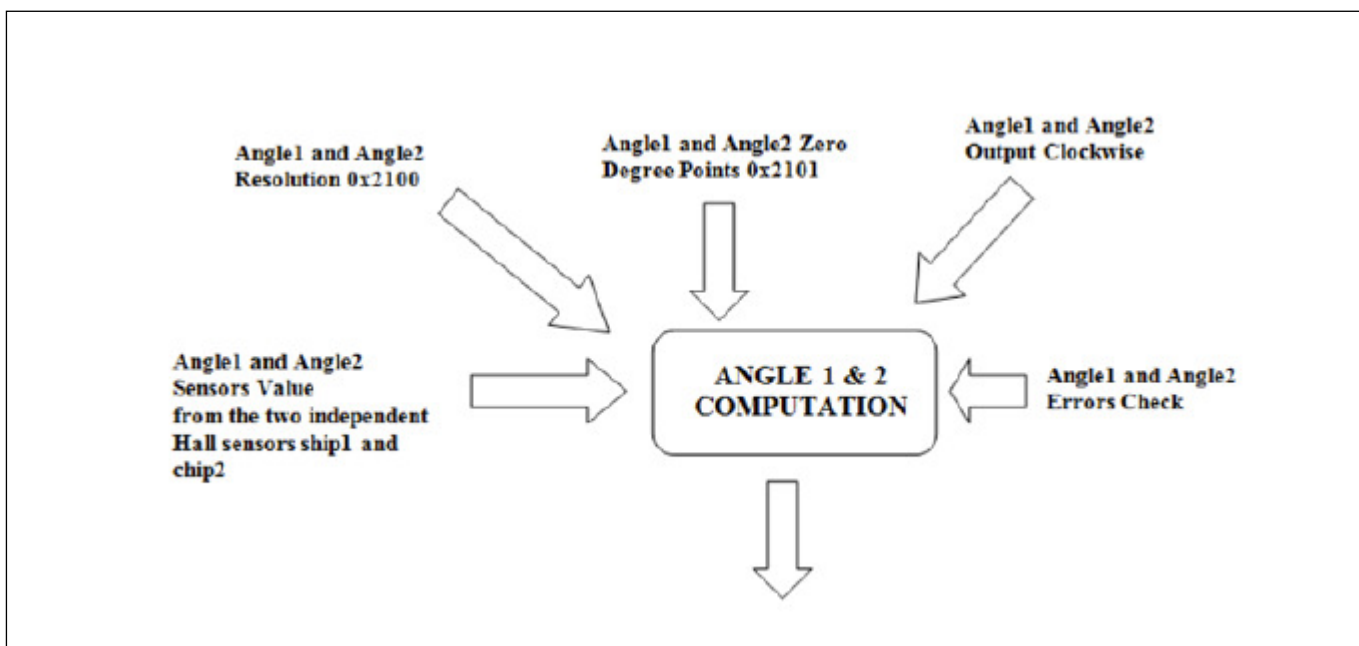
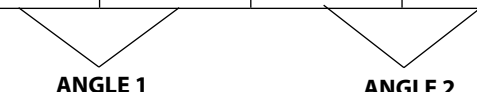

Fig. 1 Angle computation

ID	Byte 1	Byte 2	Byte 3	Byte 4	Byte 5	Byte 6	Byte 7	Byte 8
182h	00h	00h	0Eh	0Fh	FFh	FFh	FFh	00h



**Important note:**

The two angles Angle 1 and Angle 2 are obtained independently from each other (i.e. in DST X510/DST X520 series contactless rotary sensors there are two on-board HALL chips) in a sort of redundant configuration.

**12. CANopen features summary**
**Communication Profile**

The parameters which are critical for communication are determined in the Communication profile.  
This area is common for all CANopen devices.

Index	Sub Index	Name	Type	Access	Default value	Comments
1000h		Device Profile	Unsigned 32	Ro	0x00000000	No standardized device profil adapted
1001h		Error Register	Unsigned 8	Ro	0x00	Always ZERO
1008h		Manufacturer Device Name	String	Ro	"GRA" or "GRN"	Rewfer to Danfoss data sheet: GRA: DST X510 contactless rotary sensor with shaft GRN: DST X520 Contactless rotary sensor without shaft
1009h		Manufacturer Hardware Version	String	Ro	"1.00"	
100Ah		Manufacturer Software Version	String	Ro	"1.14"	
1010h	0	Number of entries	Unsigned 8	Ro	1	"save" (0x65766173) to store all parameters (objects with marking PARA)
	1	Save all parameters	Unsigned 32	Rw		
1011h	0	Restore default parameters	Unsigned 8	Ro		"load" (0x64616F6C) to restore all parameters (objects with PARA and LSS-PARA)
	1	Restore all parameters	Unsigned 32	Rw		
1014h	0	Emergency ID	Unsigned 32	Rw	0x80+Node-ID	
1017h	0	Producer time/Heart beat	Unsigned 16	Rw	0	Min. = 0 & Max. = 65536 with unit = 1ms; If 0: NOT USED
1018h	0	Identity object	Unsigned 8	Ro	4	Refer to Vendor ID: 0x0000093
	1	Vendor ID	Unsigned 32	Ro	0x0000093	
	2	Product code	Unsigned 32	Ro	0x0000064	
	3	Revision number	Unsigned 32	Ro	0x0000001	
	4	Serial number	Unsigned 32	Ro	0x0000000	

Ro = the parameter can be read only

Rw = the parameter can be read and also written

Wo = the parameter can be written only



Index	Sub Index	Name	Type	Access	Default value	Comments
<b>SDO Server Parameter</b>						
1200h	0	Number of entries	Unsigned 8	Ro	2	
	1	COB-ID Client to Server (Tx)	Unsigned 32	Ro	0x600+Node-ID	
	2	COB-ID Server to Server (tx)	Unsigned 32	Ro	0x580+Node-ID	
1800h	0	1 <sup>st</sup> Transmit PDO Parameter	Unsigned 8	Ro	Default value Ro	Comments Ro
	1	COB-ID	Unsigned 32	Ro	180h + Node-ID	Comments 180h, Node-ID
	2	Transmission Type	Unsigned 8	Rw	253	Asynchronous transmission
	3	Inhibit Time	Unsigned 16	Ro	0	Min. = 0 & Max. = 65535
	4	Reserved	//	//	14	Min. 14 Max. 14 with unit 1 ms
	5	Timer	Unsigned 16	Rw	100	Min. = 4 & Max. = 65535
<b>TxPDO Mapping Parameter</b>						
1A00h	0	Number of entries	Unsigned 8	Ro	8	Objects: 0x2110.1 0x2110.2 0x2110.3 0x2110.4 0x2110.5 0x2110.6 0x2110.7 0x4001.0
	1	1 <sup>st</sup> Mapped Object	Unsigned 32	Ro	0x21100108	
	2	2 <sup>nd</sup> Mapped Object	Unsigned 32	Ro	0x21100208	
	3	3 <sup>rd</sup> Mapped Object	Unsigned 32	Ro	0x21100308	
	4	4 <sup>th</sup> Mapped Object	Unsigned 32	Ro	0x21100408	
	5	5 <sup>th</sup> Mapped Object	Unsigned 32	Ro	0x21100508	
	6	6 <sup>th</sup> Mapped Object	Unsigned 32	Ro	0x21100608	
	7	7 <sup>th</sup> Mapped Object	Unsigned 32	Ro	0x21100708	
	8	4 <sup>th</sup> Mapped Object	Unsigned 32	Ro	0x40010008	
	2	Angle 2 Zero degree point	Unsigned 16	Ro	0	

Ro = the parameter can be read only

Rw = the parameter can be read and also written

Wo = the parameter can be written only



### Manufacturer Specific Profile Objects

In this section you will find the manufacturer specific profile indices for transducers.

Index	Sub Index	Name	Type	Access	Default value	Comments
<b>Angle Value</b>						
2000h	0	Number of entries	Unsigned 8	Ro	2	Angle sensor 1 and Angle sensor 2 in a single chip with 360° fullscale and a resolution of about 0.022°/bit Min. = 0 & Max. = 16383
	1	Angle 1 Sensor Value	Unsigned 16	Ro	0	
	2	Angle 2 Sensor Value	Unsigned 16	Ro	0	
<b>Angle Filter Function</b>						
2001h	0	Number of entries	Unsigned 8	Ro	2	Min. = 0 & Max. = 255 0: Not used NOT IMPLEMENTED
	1	Angle 1 FILTER	Unsigned 8	Rw	0	
	2	Angle 2 FILTER	Unsigned 8	Rw	0	
<b>Angle Sensor Process Data</b>						
	0	Number of entries	Unsigned 8	Ro	3	
	1	Angle 1 Process data	Unsigned 16	Ro	0	Angle 1 Process data
	2	Angle 2 Process data	Unsigned 16	Ro	0	Angle 2 Process data
	3	Angle 1 & 2 Process data	Unsigned 32	Ro	0	Angle 1 & 2 Process data sent at the same time
<b>Angle Resolution</b>						
2100h	0	Number of entries	Unsigned 8	Ro	2	The Angle 1 and 2: Resolution accepted values are: 1000d: 1° bit; 100d: 0.1° bit; 22d: 0.01° bit (14 bits effective resolution 0.02°)
	1	Angle 1 Resolution	Unsigned 16	Rw	100	
	2	Angle 2 Resolution	Unsigned 16	Rw	100	
<b>Angle Zero Degree Point</b>						
2101h	0	Number of entries	Unsigned 8	Ro	2	Angle 1 & 2 Zero Degree Point have to be in relationing with the maximum allowed degree Min. = 0 & Max. = 16383
	1	Angle 1 Zero degree point	Unsigned 16	Ro	0	
<b>Angle Clockwise</b>						
2102h	0	Number of entries	Unsigned 8	Ro	2	0: CCW 1: CW
	1	Angle 1	Unsigned 8	Rw	X	
	2	Angle 2	Unsigned 8	Rw	X	
2103h		Angle maximum difference			0	According to the ordering code NOT IMPLEMENTED
<b>Angle 1 and Angle 2 Values</b>						
2110h	0	Number of entries	Unsigned 8	Ro	4	
	1	Angle 1 Output Value Byte 0	Unsigned 8		0	Unit: 0x2100 MSB when PDO coding Big Endian (Index 0x500) is used Min.= 0 & Max. = 255
	2	Angle 1 Output Value Byte 1	Unsigned 8		0	Unit: 0x2100 MSB when PDO coding Big Endian (Index 0x500) is used Min.= 0 & Max. = 255
	3	Angle 1 Output Value Byte 0	Unsigned 8		0	Unit: 0x2100 MSB when PDO coding Big Endian (Index 0x500) is used Min.= 0 & Max. = 255
	4	Angle 1 Output Value Byte 0	Unsigned 8		0	Unit: 0x2100 MSB when PDO coding Big Endian (Index 0x500) is used Min.= 0 & Max. = 255

Index	Sub Index	Name	Type	Access	Default value	Comments
Angle Value						
4000h		Error Behavior - PARA	Unsigned 8	Rw	1	0: Pre-operational, 1: No state change 2: Stopped; Min. = 0 & Max. = 255
4001h		Error code	Unsigned 8	Ro	0	0000 0000 No error 0000 0001 Angle 1 sensor chip error 0000 0010 Angle 2 sensor chip error 0000 0100 Angle mismatch (Angle 1 vs Angle 2) error, object 0x2103 NOT IMPLEMENTED 0001 0000 Program checksum error 0100 0000 LSS Parameter checksum error 1000 0000 Magnetic field too high/low
5000h		Automatic NMT Start after Power-on - PARA	Unsigned 8	Rw	1	0: Not activated 1: Little endian Min. = 0 & Max. = 1
5001h		PDO coding standard used - PARA	Undesigned	Rw	0	0: Big endian 1: Little Endian Min. = 0 & Max. = 1
LSS Parameter						
5999h	0	Number of entries	Unsigned 8	Ro	3	
	1	Baud rate - LSS-PARA	Unsigned 16	Rw	250	Possible values: 50 kbit/s 125 kbit/s 250 kbit/s 500 kbit/s 800 kbit/s 1000 kbit/s Min. = 50 & Max. = 1000 <b>IMPORTANT:</b> use this service only if one device is connected to the network
	2	Node-ID - LSS-PARA	Unsigned 8	Rw	2	Min. = 1 & Max. = 127 <b>IMPORTANT:</b> use this service only if one device is connected to the network
	3	Store - LSS-PARA	Unsigned 32	Wo		"Save" (0x65766173) to store all LSS parameters (object with marking LSS-PARA) <b>IMPORTANT:</b> use this service only if one device is connected to the network

Ro = the parameter can be read only

Rw = the parameter can be read and also written

Wo = the parameter can be written only

### 13. Communication examples

#### Example 1: How to change the Baud Rate Setting from 250 kbaud to 500 kbaud

With Service Data Object (S.D.O) the access to entries of a device Object Dictionary is provided. As these entries may contain data of arbitrary size and data type SDOs can be used to transfer multiple data sets from a client to a server and vice versa.

#### Structure of SDO-request by the Master

COB-ID	DLC	Byte 1	Byte 2	Byte 3	Byte 4	Byte 5	Byte 6	Byte 7	Byte 8
600+Node-ID	8	CMD	Index		Sub-Index	Data			

**CMD** determines the direction of data transfer and the size of the data object:

23 hex Sending of 4-byte data (bytes 5 - 8 contain a 32 bith value)

2B hex Sending of 2-byte data (bytes 5, 6 contain a 16-bit value)

2F hex Sending of 1-byte data (byte 5 contains an 8-bit value)

#### Structure of SDO-answer by the Slave

COB-ID	DLC	Byte 1	Byte 2	Byte 3	Byte 4	Byte 5	Byte 6	Byte 7	Byte 8
580+Node-ID	8	CMD	Index		Sub-Index	Data			

#### RES Response of Slave:

60 hex Data sent successfully

80 hex Error

#### Write (in the example the Node-ID = 0x03)

COB-ID	Byte 1	Byte 2	Byte 3	Byte 4	Byte 5	Byte 6	Byte 7	Byte 8
603h	2Bh	99h	59h	01h	F4h	01h	00h	00h

5999h		LSS Parameter				
	0	Number of entries	Unsigned 8	Ro	3	
	1	Baud rate - LSS-PARA	Unsigned 16	Rw	500	Possible values: 50 kbit/s 125 kbit/s 250 kbit/s 500 kbit/s 800 kbit/s 1000 kbit/s Min. = 50 & Max. = 1000 <b>IMPORTANT:</b> use this service only if one device is connected to the network
	2	Node-ID - LSS-PARA	Unsigned 8	Rw	2	Min. = 1 & Max. = 127 <b>IMPORTANT:</b> use this service only if one device is connected to the network
	3	Store - LSS-PARA	IUnsigned 32	Wo		"Save" (0x65766173) to store all LSS parameters (object with marking LSS-PARA) <b>IMPORTANT:</b> use this service only if one device is connected to the network

The supported baudrate are listed in the following table:

Byte 5	Byte 6	Baudrate
32h	00h	50 Kbaud
7Dh	00h	125 Kbaud
FAh	00h	250 Kbaud
F4h	01h	500 Kbaud
20h	03h	800 Kbaud
E8h	03h	1Mbaud

The answer after successful storing you will receive is:

ID	Byte 1	Byte 2	Byte 3	Byte 4	Byte 5	Byte 6	Byte 7	Byte 8
583h	60h	99h	59h	01h	00h	00h	00h	00h

With the aim to save new Baud Rate write the "save" command as below:

**Write (in the example the Node-ID = 0x03)**

ID	Byte 1	Byte 2	Byte 3	Byte 4	Byte 5	Byte 6	Byte 7	Byte 8
603h	23h	99h	59h	03h	73h	61h	76h	65h

**Note:** save command is given by sending the code:

73h	61h	76h	65h
-----	-----	-----	-----

Where:

**73h** = ASCII code "s"

**61h** = ASCII code "a"

**76h** = ASCII code "v"

**65h** = ASCII code "e"

The answer after successful storing you will receive is:

ID	Byte 1	Byte 2	Byte 3	Byte 4	Byte 5	Byte 6	Byte 7	Byte 8
583h	60h	99h	59h	03h	00h	00h	00h	00h

**IMPORTANT NOTE:**

After setting the new entries a reset must be made so that the new entries become valid (switch off the module for a short time).

**Example 2: How to change the ID-Node from 0x03h (3d) to 0x06h (6d)**

With Service Data Object (S.D.O) the access to entries of a device Object Dictionary is provided. As these entries may contain data of arbitrary size and data type SDOs can be used to transfer multiple data sets from a client to a server and vice versa.

**Structure of SDO-request by the Master**

COB-ID	DLC	Byte 1	Byte 2	Byte 3	Byte 4	Byte 5	Byte 6	Byte 7	Byte 8
600+Node-ID	8	CMD	Index		Sub-Index	Data			

**CMD** determines the direction of data transfer and the size of the data object:

23 hex Sending of 4-byte data (bytes 5 - 8 contain a 32 bit value)

2B hex Sending of 2-byte data (bytes 5, 6 contain a 16-bit value)

2F hex Sending of 1-byte data (byte 5 contains an 8-bit value)

**Structure of SDO-answer by the Slave**

COB-ID	DLC	Byte 1	Byte 2	Byte 3	Byte 4	Byte 5	Byte 6	Byte 7	Byte 8
580+Node-ID	8	CMD	Index		Sub-Index	Data			

**RES Response of Slave:**

60 hex Data sent successfully

80 hex Error

**Write (in the example the Node-ID = 0x03)**

COB-ID	Byte 1	Byte 2	Byte 3	Byte 4	Byte 5	Byte 6	Byte 7	Byte 8
603h	2Bh	99h	59h	02h	F4h	06h	00h	00h

5999h		LSS Parameter				
	0	Number of entries	Unsigned 8	Ro	3	
	1	Baud rate - LSS-PARA	Unsigned 16	Rw	250	Possible values: 50 kbit/s 125 kbit/s 250 kbit/s 500 kbit/s 800 kbit/s 1000 kbit/s Min. = 50 & Max. = 1000 <b>IMPORTANT:</b> use this service only if one device is connected to the network
	2	Node-ID - LSS-PARA	Unsigned 8	Rw	6	Min. = 1 & Max. = 127 <b>IMPORTANT:</b> use this service only if one device is connected to the network
	3	Store - LSS-PARA	IUnsigned 32	Wo		"Save" (0x65766173) to store all LSS parameters (object with marking LSS-PARA) <b>IMPORTANT:</b> use this service only if one device is connected to the network

To supported Node-ID are 0x01 to 0x7F

The answer after successful storing you will receive is:

ID	Byte 1	Byte 2	Byte 3	Byte 4	Byte 5	Byte 6	Byte 7	Byte 8
583h	60h	99h	59h	02h	00h	00h	00h	00h

With the aim to save new Baud Rate write the "save" command as below:

**Write (in the example the Node-ID = 0x03)**

ID	Byte 1	Byte 2	Byte 3	Byte 4	Byte 5	Byte 6	Byte 7	Byte 8
603h	23h	99h	59h	03h	73h	61h	76h	65h

**Note:** save command is given by sending the code:

73h	61h	76h	65h
-----	-----	-----	-----

Where:

**73h** = ASCII code "s"

**61h** = ASCII code "a"

**76h** = ASCII code "v"

**65h** = ASCII code "e"

The answer after successful storing you will receive is:

ID	Byte 1	Byte 2	Byte 3	Byte 4	Byte 5	Byte 6	Byte 7	Byte 8
583h	60h	99h	59h	03h	00h	00h	00h	00h

**IMPORTANT NOTE:**

After setting the new entries a reset must be made so that the new entries become valid (switch off the module for a short time).

**Example 3: How to activate an automatic NMT Start after Power ON (the PDO will be send automatically after power ON)**

With Service Data Object (S.D.O) the access to entries of a device Object Dictionary is provided. As these entries may contain data of arbitrary size and data type SDOs can be used to transfer multiple data sets from a client to a server and vice versa.

**Structure of SDO-request by the Master**

COB-ID	DLC	Byte 1	Byte 2	Byte 3	Byte 4	Byte 5	Byte 6	Byte 7	Byte 8
600+Node-ID	8	CMD	Index		Sub-Index	Data			

**CMD** determines the direction of data transfer and the size of the data object:

23 hex Sending of 4-byte data (bytes 5 - 8 contain a 32 bit value)

2B hex Sending of 2-byte data (bytes 5, 6 contain a 16-bit value)

2F hex Sending of 1-byte data (byte 5 contains an 8-bit value)

**Structure of SDO-answer by the Slave**

COB-ID	DLC	Byte 1	Byte 2	Byte 3	Byte 4	Byte 5	Byte 6	Byte 7	Byte 8
580+Node-ID	8	CMD	Index		Sub-Index	Data			

**RES Response of Slave:**

60 hex Data sent successfully

80 hex Error

**Write (in the example the Node-ID = 0x03)**

COB-ID	Byte 1	Byte 2	Byte 3	Byte 4	Byte 5	Byte 6	Byte 7	Byte 8
603h	2Fh	00h	50h	00h	01h	00h	00h	00h

**Object:**

5000h	Automatic NMT Start after Power-On - PARA	Unsigned 8	Rw	1	0: Not activated 1: Activated Min. = 0 & Max. = 1			
-------	---	------------	----	---	---	--	--	--

With the aim to save new Baud Rate write the "save" command as below:

**Write (in the example the Node-ID = 0x03)**

ID	Byte 1	Byte 2	Byte 3	Byte 4	Byte 5	Byte 6	Byte 7	Byte 8
603h	23h	10h	10h	01h	73h	61h	76h	65h

**Note:** save command is given by sending the code:

73h	61h	76h	65h
-----	-----	-----	-----

Where:

**73h** = ASCII code "s"

**61h** = ASCII code "a"

**76h** = ASCII code "v"

**65h** = ASCII code "e"

The answer after successful storing you will receive is:

ID	Byte 1	Byte 2	Byte 3	Byte 4	Byte 5	Byte 6	Byte 7	Byte 8
583h	60h	10h	10h	01h	00h	00h	00h	00h

**IMPORTANT NOTE:**

After setting the new entries a reset must be made so that the new entries become valid (switch off the module for a short time).

**Example 4: How to change the PDO rate (time interval) from 100 ms to 20 ms**

With Service Data Object (S.D.O) the access to entries of a device Object Dictionary is provided. As these entries may contain data of arbitrary size and data type SDOs can be used to transfer multiple data sets from a client to a server and vice versa.

**Structure of SDO-request by the Master**

COB-ID	DLC	Byte 1	Byte 2	Byte 3	Byte 4	Byte 5	Byte 6	Byte 7	Byte 8
600+Node-ID	8	CMD	Index		Sub-Index	Data			

**CMD** determines the direction of data transfer and the size of the data object:

23 hex Sending of 4-byte data (bytes 5 - 8 contain a 32 bit value)

2B hex Sending of 2-byte data (bytes 5, 6 contain a 16-bit value)

2F hex Sending of 1-byte data (byte 5 contains an 8-bit value)

**Structure of SDO-answer by the Slave**

COB-ID	DLC	Byte 1	Byte 2	Byte 3	Byte 4	Byte 5	Byte 6	Byte 7	Byte 8
580+Node-ID	8	CMD	Index		Sub-Index	Data			

**RES Response of Slave:**

60 hex Data sent successfully

80 hex Error

**Write (in the example the Node-ID = 0x03)**

COB-ID	Byte 1	Byte 2	Byte 3	Byte 4	Byte 5	Byte 6	Byte 7	Byte 8
603h	2Bh	00h	18h	05h	14h	00h	00h	00h

**Object:**

1800h	0	1st Transmit PDO Parameter	Unsigned 8	Ro		
	1	COB-ID	Unsigned 32	Ro	180h+Node-ID	
	2	Transmission Type	Unsigned 8	Rw	254	PAsynchronous transmission
	3	Inhibit Time	Unsigned 16	Ro	0	Min. = 0 & Max. = 65535 with unit = 1 ms
	4	Reserved	//	//		
	5	Timer	Unsigned 16	Rw	20	Min. = 4 & Max. = 65535 with unit = 1 ms

The answer after succesful storing you will receive is:

ID	Byte 1	Byte 2	Byte 3	Byte 4	Byte 5	Byte 6	Byte 7	Byte 8
583h	60h	00h	18h	05h	00h	00h	00h	00h



With the aim to save new Baud Rate write the "save" command as below:

**Write (in the example the Node-ID = 0x03)**

ID	Byte 1	Byte 2	Byte 3	Byte 4	Byte 5	Byte 6	Byte 7	Byte 8
603h	23h	10h	10h	01h	73h	61h	76h	65h

**Note:** save command is given by sending the code:

73h	61h	76h	65h
-----	-----	-----	-----

Where:

**73h** = ASCII code "s"

**61h** = ASCII code "a"

**76h** = ASCII code "v"

**65h** = ASCII code "e"

The answer after successful storing you will receive is:

ID	Byte 1	Byte 2	Byte 3	Byte 4	Byte 5	Byte 6	Byte 7	Byte 8
583h	60h	10h	10h	01h	00h	00h	00h	00h

**IMPORTANT NOTE:**

After setting the new entries a reset must be made so that the new entries become valid (switch off the module for a short time).

**Example 5: How to set the ZERO degree point to Angle 1 (example with resolution  $\pm 0.1^\circ$ )**

With Service Data Object (S.D.O) the access to entries of a device Object Dictionary is provided. As these entries may contain data of arbitrary size and data type SDOs can be used to transfer multiple data sets from a client to a server and vice versa.

**Structure of SDO-request by the Master**

COB-ID	DLC	Byte 1	Byte 2	Byte 3	Byte 4	Byte 5	Byte 6	Byte 7	Byte 8
600+Node-ID	8	CMD	Index		Sub-Index	Data			

**CMD** determines the direction of data transfer and the size of the data object:

23 hex Sending of 4-byte data (bytes 5 - 8 contain a 32 bit value)

2B hex Sending of 2-byte data (bytes 5, 6 contain a 16-bit value)

2F hex Sending of 1-byte data (byte 5 contains an 8-bit value)

**Structure of SDO-answer by the Slave**

COB-ID	DLC	Byte 1	Byte 2	Byte 3	Byte 4	Byte 5	Byte 6	Byte 7	Byte 8
580+Node-ID	8	CMD	Index		Sub-Index	Data			

**RES Response of Slave:**

60 hex Data sent successfully

80 hex Error

**Write (in the example the Node-ID = 0x03)**

If the actual value of the Angle 1 is 02h 65 h = 0265 h = 613 d = 61.3° with the aim to move the Angle 1 to ZERO add to Byte 5 and Byte 6 the values below:

COB-ID	Byte 1	Byte 2	Byte 3	Byte 4	Byte 5	Byte 6	Byte 7	Byte 8
603h	2Bh	01h	21h	01h	65h	02h	00h	00h

**Object:**

2101h		Angle ZERO Degree Point				The Angle 1 and Angle 2 ZERO Degree Point have to be in relation with the mas. allowed degree Min. = 0 & Max. = 16383
	0	Number of entries	Unsigned 8	Ro	2	
	1	Angle 1 ZERO Degree Point	Unsigned 16	Rw	613	
	2	Angle 2 ZERO Degree Point	Unsigned 16	Rw	0	

The answer after succesful storing you will receive is:

ID	Byte 1	Byte 2	Byte 3	Byte 4	Byte 5	Byte 6	Byte 7	Byte 8
583h	60h	01h	21h	01h	00h	00h	00h	00h

With the aim to save new Baud Rate write the "save" command as below:

**Write (in the example the Node-ID = 0x03)**

ID	Byte 1	Byte 2	Byte 3	Byte 4	Byte 5	Byte 6	Byte 7	Byte 8
603h	23h	10h	10h	01h	73h	61h	76h	65h

**Note:** save command is given by sending the code:

73h	61h	76h	65h
-----	-----	-----	-----

Where:

**73h** = ASCII code "s"

**61h** = ASCII code "a"

**76h** = ASCII code "v"

**65h** = ASCII code "e"

The answer after successful storing you will receive is:

ID	Byte 1	Byte 2	Byte 3	Byte 4	Byte 5	Byte 6	Byte 7	Byte 8
583h	60h	10h	10h	01h	00h	00h	00h	00h

**IMPORTANT NOTE:**

After setting the new entries a reset must be made so that the new entries become valid (switch off the module for a short time).

**Example 6: How to set the ZERO degree point to Angle 2 (example with resolution  $\pm 0.1^\circ$ )**

With Service Data Object (S.D.O) the access to entries of a device Object Dictionary is provided. As these entries may contain data of arbitrary size and data type SDOs can be used to transfer multiple data sets from a client to a server and vice versa.

**Structure of SDO-request by the Master**

COB-ID	DLC	Byte 1	Byte 2	Byte 3	Byte 4	Byte 5	Byte 6	Byte 7	Byte 8
600+Node-ID	8	CMD	Index		Sub-Index	Data			

**CMD** determines the direction of data transfer and the size of the data object:

23 hex Sending of 4-byte data (bytes 5 - 8 contain a 32 bit value)

2B hex Sending of 2-byte data (bytes 5, 6 contain a 16-bit value)

2F hex Sending of 1-byte data (byte 5 contains an 8-bit value)

**Structure of SDO-answer by the Slave**

COB-ID	DLC	Byte 1	Byte 2	Byte 3	Byte 4	Byte 5	Byte 6	Byte 7	Byte 8
580+Node-ID	8	CMD	Index		Sub-Index	Data			

**RES Response of Slave:**

60 hex Data sent successfully

80 hex Error

**Write (in the example the Node-ID = 0x03)**

If the actual value of the Angle 1 is 02h 65 h = 0265 h = 613 d = 61.3° with the aim to move the Angle 2 to ZERO add to Byte 5 and Byte 6 the values below:

COB-ID	Byte 1	Byte 2	Byte 3	Byte 4	Byte 5	Byte 6	Byte 7	Byte 8
603h	2Bh	01h	21h	02h	65h	02h	00h	00h

**Object:**

2101h		Angle ZERO Degree Point				The Angle 1 and Angle 2 ZERO Degree Point have to be in relation with the mas. allowed degree Min. = 0 & Max. = 16383
	0	Number of entries	Unsigned 8	Ro	2	
	1	Angle 1 ZERO Degree Point	Unsigned 16	Rw	0	
	2	Angle 2 ZERO Degree Point	Unsigned 16	Rw	613	

The answer after succesful storing you will receive is:

ID	Byte 1	Byte 2	Byte 3	Byte 4	Byte 5	Byte 6	Byte 7	Byte 8
583h	60h	01h	21h	02h	00h	00h	00h	00h

With the aim to save new Baud Rate write the "save" command as below:

**Write (in the example the Node-ID = 0x03)**

ID	Byte 1	Byte 2	Byte 3	Byte 4	Byte 5	Byte 6	Byte 7	Byte 8
603h	23h	10h	10h	01h	73h	61h	76h	65h

**Note:** save command is given by sending the code:

73h	61h	76h	65h
-----	-----	-----	-----

Where:

**73h** = ASCII code "s"

**61h** = ASCII code "a"

**76h** = ASCII code "v"

**65h** = ASCII code "e"

The answer after successful storing you will receive is:

ID	Byte 1	Byte 2	Byte 3	Byte 4	Byte 5	Byte 6	Byte 7	Byte 8
583h	60h	10h	10h	01h	00h	00h	00h	00h

**IMPORTANT NOTE:**

After setting the new entries a reset must be made so that the new entries become valid (switch off the module for a short time).

**Example 7: How to set the resolution to  $\pm 0.1^\circ$  on Angle 1 and Angle 2 (the current setting resolution is  $\pm 0.1^\circ$ )**

With Service Data Object (S.D.O) the access to entries of a device Object Dictionary is provided. As these entries may contain data of arbitrary size and data type SDOs can be used to transfer multiple data sets from a client to a server and vice versa.

**Structure of SDO-request by the Master**

COB-ID	DLC	Byte 1	Byte 2	Byte 3	Byte 4	Byte 5	Byte 6	Byte 7	Byte 8
600+Node-ID	8	CMD	Index		Sub-Index	Data			

**CMD** determines the direction of data transfer and the size of the data object:

23 hex Sending of 4-byte data (bytes 5 - 8 contain a 32 bit value)

2B hex Sending of 2-byte data (bytes 5, 6 contain a 16-bit value)

2F hex Sending of 1-byte data (byte 5 contains an 8-bit value)

**Structure of SDO-answer by the Slave**

COB-ID	DLC	Byte 1	Byte 2	Byte 3	Byte 4	Byte 5	Byte 6	Byte 7	Byte 8
580+Node-ID	8	CMD	Index		Sub-Index	Data			

**RES Response of Slave:**

60 hex Data sent successfully

80 hex Error

With the aim to set the resolution on Angle 1 to  $\pm 0.01^\circ$  send write the PDO (in the example the Node-ID = 0x03)

COB-ID	Byte 1	Byte 2	Byte 3	Byte 4	Byte 5	Byte 6	Byte 7	Byte 8
603h	2Bh	00h	21h	01h	64h	02h	00h	00h

**Object:**

2100h	Angle RESOLUTION				The Angle 1 and Angle 2 Resolution accepted values are: 1000d: 1 Deg/bit 100d: 0.1 Deg/bit 22d: 0.01 Deg/bit (14 bits effective resolution 0.02°)	
	0	Number of entries	Unsigned 8	Ro		2
	1	Angle 1 Resolution	Unsigned 16	Rw		100
	2	Angle 2 Resolution	Unsigned 16	Rw		22

When the aim to set the resolution on Angle 2 to  $\pm 0.01^\circ$  send write the PDO (in the example Node-ID = 0x03):

ID	Byte 1	Byte 2	Byte 3	Byte 4	Byte 5	Byte 6	Byte 7	Byte 8
603h	2Bh	01h	21h	02h	64h	00h	00h	00h

**Object:**

2100h		Angle RESOLUTION				The Angle 1 and Angle 2 Resolution accepted values are: 1000d: 1 Deg/bit 100d: 0.1 Deg/bit 22d: 0.01 Deg/bit (14 bits effective resolution 0.02°)		
	0	Number of entries	Unsigned 8	Ro	2			
	1	Angle 1 Resolution	Unsigned 16	Rw	100			
	2	Angle 2 Resolution	Unsigned 16	Rw	100			

The answer after succesful storing you will receive is:

ID	Byte 1	Byte 2	Byte 3	Byte 4	Byte 5	Byte 6	Byte 7	Byte 8
583h	60h	01h	21h	01h	00h	00h	00h	00h

With the aim to save new Baud Rate write the "save" command as below:

**Write (in the example the Node-ID = 0x03)**

ID	Byte 1	Byte 2	Byte 3	Byte 4	Byte 5	Byte 6	Byte 7	Byte 8
603h	23h	10h	10h	03h	73h	61h	76h	65h

With the aim to save new Baud Rate write the "save" command as below:

**Write (in the example the Node-ID = 0x03)**

ID	Byte 1	Byte 2	Byte 3	Byte 4	Byte 5	Byte 6	Byte 7	Byte 8
603h	23h	10h	10h	01h	73h	61h	76h	65h

**Note:** save command is given by sending the code:

73h	61h	76h	65h
-----	-----	-----	-----

Where:

**73h** = ASCII code "s"

**61h** = ASCII code "a"

**76h** = ASCII code "v"

**65h** = ASCII code "e"

The answer after successfull storing you will receive is:

ID	Byte 1	Byte 2	Byte 3	Byte 4	Byte 5	Byte 6	Byte 7	Byte 8
583h	60h	10h	10h	01h	00h	00h	00h	00h

**IMPORTANT NOTE:**

After setting the new entries a reset must be made so that the new entries become valid (switch off the module for a short time).

**Example 8: How to set the resolution to  $\pm 0.1^\circ$  on Angle 1 and Angle 2 (the current setting resolution is  $\pm 0.1^\circ$ )**

With Service Data Object (S.D.O) the access to entries of a device Object Dictionary is provided. As these entries may contain data of arbitrary size and data type SDOs can be used to transfer multiple data sets from a client to a server and vice versa.

**Structure of SDO-request by the Master**

COB-ID	DLC	Byte 1	Byte 2	Byte 3	Byte 4	Byte 5	Byte 6	Byte 7	Byte 8
600+Node-ID	8	CMD	Index		Sub-Index	Data			

**CMD** determines the direction of data transfer and the size of the data object:

23 hex Sending of 4-byte data (bytes 5 - 8 contain a 32 bit value)

2B hex Sending of 2-byte data (bytes 5, 6 contain a 16-bit value)

2F hex Sending of 1-byte data (byte 5 contains an 8-bit value)

**Structure of SDO-answer by the Slave**

COB-ID	DLC	Byte 1	Byte 2	Byte 3	Byte 4	Byte 5	Byte 6	Byte 7	Byte 8
580+Node-ID	8	CMD	Index		Sub-Index	Data			

**RES Response of Slave:**

60 hex Data sent successfully

80 hex Error

With the aim to set the resolution on Angle 1 to  $\pm 0.01^\circ$  send write the PDO (in the example the Node-ID = 0x03)

COB-ID	Byte 1	Byte 2	Byte 3	Byte 4	Byte 5	Byte 6	Byte 7	Byte 8
603h	2Bh	00h	21h	01h	16h	02h	00h	00h

**Object:**

2100h	0	Angle RESOLUTION				The Angle 1 and Angle 2 Resolution accepted values are: 1000d: 1 Deg/bit 100d: 0.1 Deg/bit 22d: 0.01 Deg/bit (14 bits effective resolution 0.02°)
	0	Number of entries	Unsigned 8	Ro	2	
	1	Angle 1 Resolution	Unsigned 16	Rw	22	
	2	Angle 2 Resolution	Unsigned 16	Rw	100	

When the aim to set the resolution on Angle 2 to  $\pm 0.01^\circ$  send write the PDO (in the example Node-ID = 0x03):

ID	Byte 1	Byte 2	Byte 3	Byte 4	Byte 5	Byte 6	Byte 7	Byte 8
603h	2Bh	00h	21h	02h	16h	00h	00h	00h



**Object:**

2100h		Angle RESOLUTION				The Angle 1 and Angle 2 Resolution accepted values are: 1000d: 1 Deg/bit 100d: 0.1 Deg/bit 22d: 0.01 Deg/bit (14 bits effective resolution 0.02°)		
	0	Number of entries	Unsigned 8	Ro	2			
	1	Angle 1 Resolution	Unsigned 16	Rw	100			
	2	Angle 2 Resolution	Unsigned 16	Rw	220			

The answer after succesful storing you will receive is:

ID	Byte 1	Byte 2	Byte 3	Byte 4	Byte 5	Byte 6	Byte 7	Byte 8
583h	60h	00h	21h	01h	00h	00h	00h	00h

ID	Byte 1	Byte 2	Byte 3	Byte 4	Byte 5	Byte 6	Byte 7	Byte 8
583h	60h	00h	21h	02h	00h	00h	00h	00h

With the aim to save new Baud Rate write the “save” command as below:

**Write (in the example the Node-ID = 0x03)**

ID	Byte 1	Byte 2	Byte 3	Byte 4	Byte 5	Byte 6	Byte 7	Byte 8
603h	23h	10h	10h	01h	73h	61h	76h	65h

**Note:** save command is given by sending the code:

73h	61h	76h	65h
-----	-----	-----	-----

Where:

**73h** = ASCII code “s”

**61h** = ASCII code “a”

**76h** = ASCII code “v”

**65h** = ASCII code “e”

The answer after successfull storing you will receive is:

ID	Byte 1	Byte 2	Byte 3	Byte 4	Byte 5	Byte 6	Byte 7	Byte 8
583h	60h	10h	10h	01h	00h	00h	00h	00h

**IMPORTANT NOTE:**

After setting the new entries a reset must be made so that the new entries become valid (switch off the module for a short time).

**Example 9: How to send the command**
**RESTORE**

With Service Data Object (S.D.O) the access to entries of a device Object Dictionary is provided. As these entries may contain data of arbitrary size and data type SDOs can be used to transfer multiple data sets from a client to a server and vice versa.

**Structure of SDO-request by the Master**

COB-ID	DLC	Byte 1	Byte 2	Byte 3	Byte 4	Byte 5	Byte 6	Byte 7	Byte 8
600+Node-ID	8	CMD	Index		Sub-Index	Data			

**CMD** determines the direction of data transfer and the size of the data object:

23 hex Sending of 4-byte data (bytes 5 - 8 contain a 32 bit value)

2B hex Sending of 2-byte data (bytes 5, 6 contain a 16-bit value)

2F hex Sending of 1-byte data (byte 5 contains an 8-bit value)

**Structure of SDO-answer by the Slave**

COB-ID	DLC	Byte 1	Byte 2	Byte 3	Byte 4	Byte 5	Byte 6	Byte 7	Byte 8
580+Node-ID	8	CMD	Index		Sub-Index	Data			

**RES Response of Slave:**

60 hex Data sent successfully

80 hex Error

**Write (in example the Node-ID = 0x7F)**

ID	Byte 1	Byte 2	Byte 3	Byte 4	Byte 5	Byte 6	Byte 7	Byte 8
67Fh	23h	11h	10h	01h	6Ch	6Fh	61h	64h

**Object:**

1011h	1	Load all parameters	Unsigned 8	Wo	"Load" (0x64616F6C) to restore all parameters (objects with marking PARA and LSS-PARA)			
-------	---	---------------------	------------	----	--	--	--	--

The answer after successful storing you will receive is:

ID	Byte 1	Byte 2	Byte 3	Byte 4	Byte 5	Byte 6	Byte 7	Byte 8
5FFh	60h	11h	10h	01h	00h	00h	00h	00h

**IMPORTANT NOTE:**

After setting the new entries a reset must be made so that the new entries become valid (switch off the module for a short time).



ENGINEERING  
TOMORROW

*Danfoss*

Danfoss A/S | Industrial Automation | Nordborgvej 81 | DK-6430 Nordborg | Denmark | [www.ia.danfoss.com](http://www.ia.danfoss.com)

---

Danfoss can accept no responsibility for possible errors in catalogues, brochures and other printed material. Danfoss reserves the right to alter its products without notice. This also applies to products already on order provided that such alterations can be made without subsequential changes being necessary in specifications already agreed. All trademarks in this material are property of the respective companies. Danfoss and the Danfoss logotype are trademarks of Danfoss A/S. All rights reserved.

---