



Perfect control, Perfect performance

AHQM/AHPBM-F control valve

Contents

- Introduction - What is AHQM/AHPBM-F?
- Customer value – Core features & benefits
- How does AHQM work? The design
- Application, system design & installation
- Main technical features & data
- Easy valve selection and dimensioning





Multi-functional control valves from Danfoss

- The AHQM is a multi-functional control valve with integrated differential pressure controller and flow limiter.
- The version AHPBM-F is a self-acting differential pressure controller (fixed setting) with flow limitation and integrated control valve.



Perfect control, Perfect performance

- The goal of any heating and cooling system is clear:
- Creating individual indoor comfort and do it energy efficient at minimal cost. It's not only the investment expenses that are important; the environmental impact also needs to be taken into account.
- This means installations need to be easy to construct and maintain by using as little energy as possible.



For micro heating networks and low temperature systems

- The Danfoss AHQM/AHPBM-F multi-functional control valves are extremely compact and are perfectly suited for the demands in micro heating networks and low temperature district heating and cooling systems.
- AHQM/AHPBM-F enable you to make fast installation and trouble-free commissioning of the heating/cooling network.
- In operation it optimises the system to give maximum comfort and minimum energy consumption.

Contents

- Introduction - What is AHQM/AHPBM-F?
- Customer value – Core features & benefits
- How does AHQM work? The design
- Application, system design & installation
- Main technical features & data
- Easy valve selection and dimensioning





With the AHQM controller you get these benefits

- One-product – multiple applications (integrates the function of 3 control valves)
 - Motorized Control Valve
 - Differential pressure controller
 - Flow limitation
- Easy valve selection
- Small built-in dimensions in the application due to compact design
- Increased comfort and lifetime
- Low installation and commissioning costs
- High valve authority (V_a) $\sim 100\%$



Simple valve selection

- Easy selection for you as the consultant or installer – only the designed flow rate is required for correct selection of the appropriate valve size
- Minimum available differential pressure ~ 0,3 bar.
- Max available differential pressure = 4 bar
- Max. flow rates:
 - DN15: 0,43 – 0,7 – 1,0 m³/h
 - DN20: 1,2 m³/h
 - DN25: 2,2 m³/h
 - DN32: 3,4 m³/h

One product for multiple applications

Always a perfect match

- AHQM/AHPBM-F can be combined with a wide range of Danfoss electrical actuators and controllers enabling usage in multiple applications and system designs.
- The AHQM has a standard actuator connection (M30x1,5mm) and can be fitted with a broad range of Danfoss electrical actuators, e.g. types AMV(E)-H 130/140 – AMV 150 and AMV(E) 13 with DIN approved safety function (DIN 32730).





Increased comfort and life time

Full valve authority ($V_a \sim 100\%$)

- The AHQM control valve has an integrated differential pressure controller that keeps the differential pressure across the control valve constant. Because of this, the control valve automatically has an authority of 100% which provides stable and precise temperature control.
- With full valve authority ($V_a \sim 100\%$) time can be saved since no complicated calculation is needed.



Low installation and commissioning costs

Easy flow setting

- The multi-functional AHQM control valve does the job for typically up to 3 stand-alone valves.
- Fast and flexible commissioning is done due to flow setting without use of tools and easy adjustment in case of changes in system design conditions.
The system can easily be adapted or re-commissioned) to the new conditions
- The control features of the AHQM valve ensure that the flow in the installation is accurately controlled under all circumstances and independent of the load on the system.

Contents

- Introduction - What is AHQM/AHPBM-F?
- Customer value – Core features & benefits
- How does AHQM work? The design
- Application, system design & installation
- Main technical features & data
- Easy valve selection and dimensioning



How does AHQM work?

- The AH-QM consists basically out of 3 parts:
- A control valve
- An integrated differential pressure controller
- A flow limiter / Adjustable restriction screw.

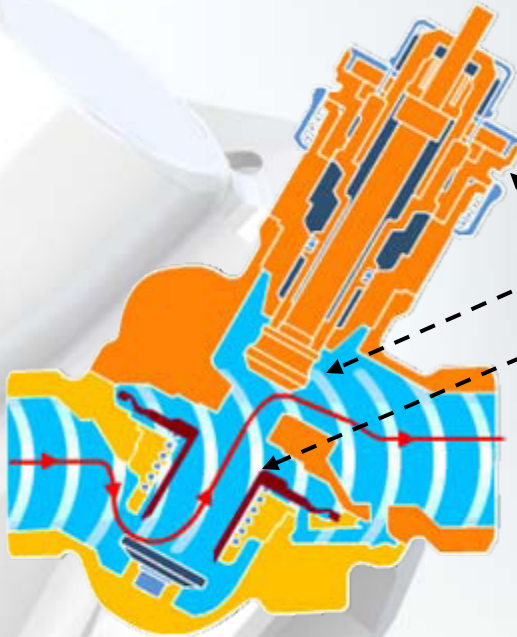

How does AHQM work?

- The integrated differential pressure controller keeps a constant differential pressure across the control valve.
- $\text{Max } Q = K_v \times \sqrt{\Delta p}$
- Constant differential pressure and a known K_v value enable you to limit the max flow rate.



How does AHQM work?

- So, AHQM gives stable control with maximal precision
- Perfect control for prefect performance!

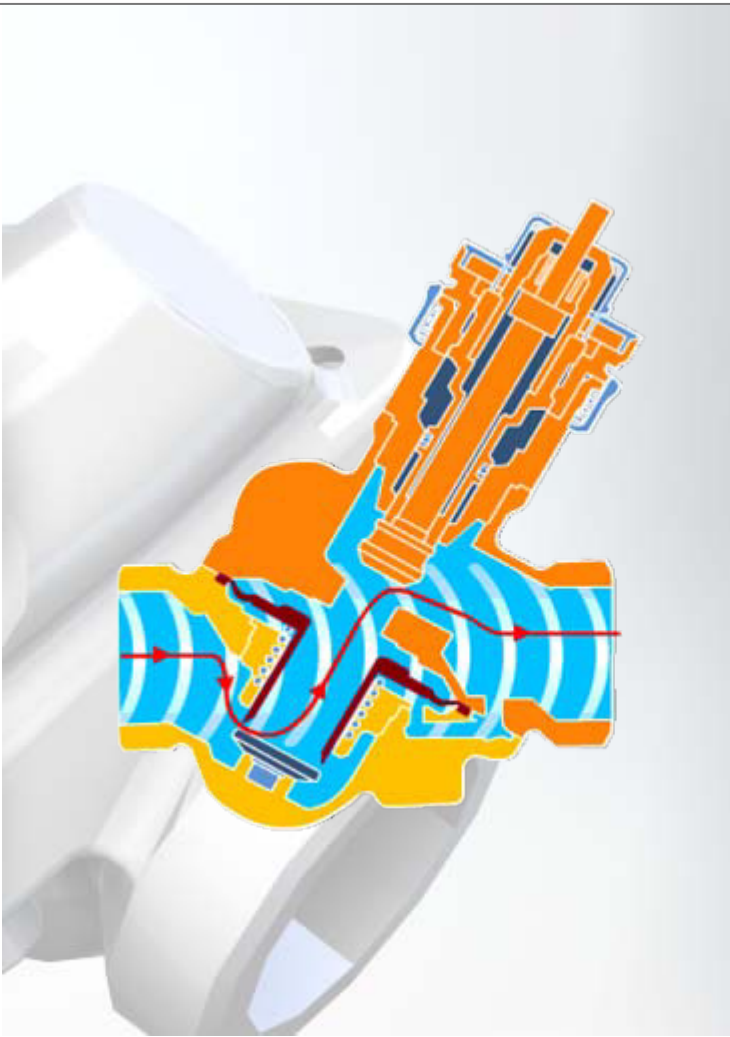

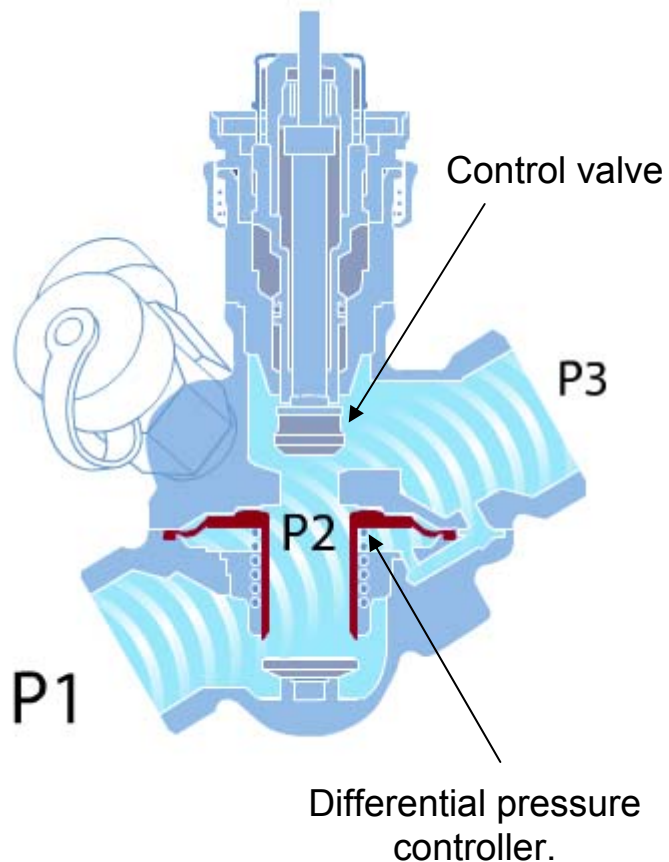

How does AHQM work?

- P1 and P3 are the available differential pressure across the AHQM valve.
- The integrated differential pressure controller maintains a constant and low differential pressure across the control valve (P2-P3).
- The built-in diaphragm maintains a constant low differential pressure across the valve cone (P2 and P3)
- The designed flow is not affected by other factors in the system such as variation in available differential pressure.

The basic working principle of AHQM

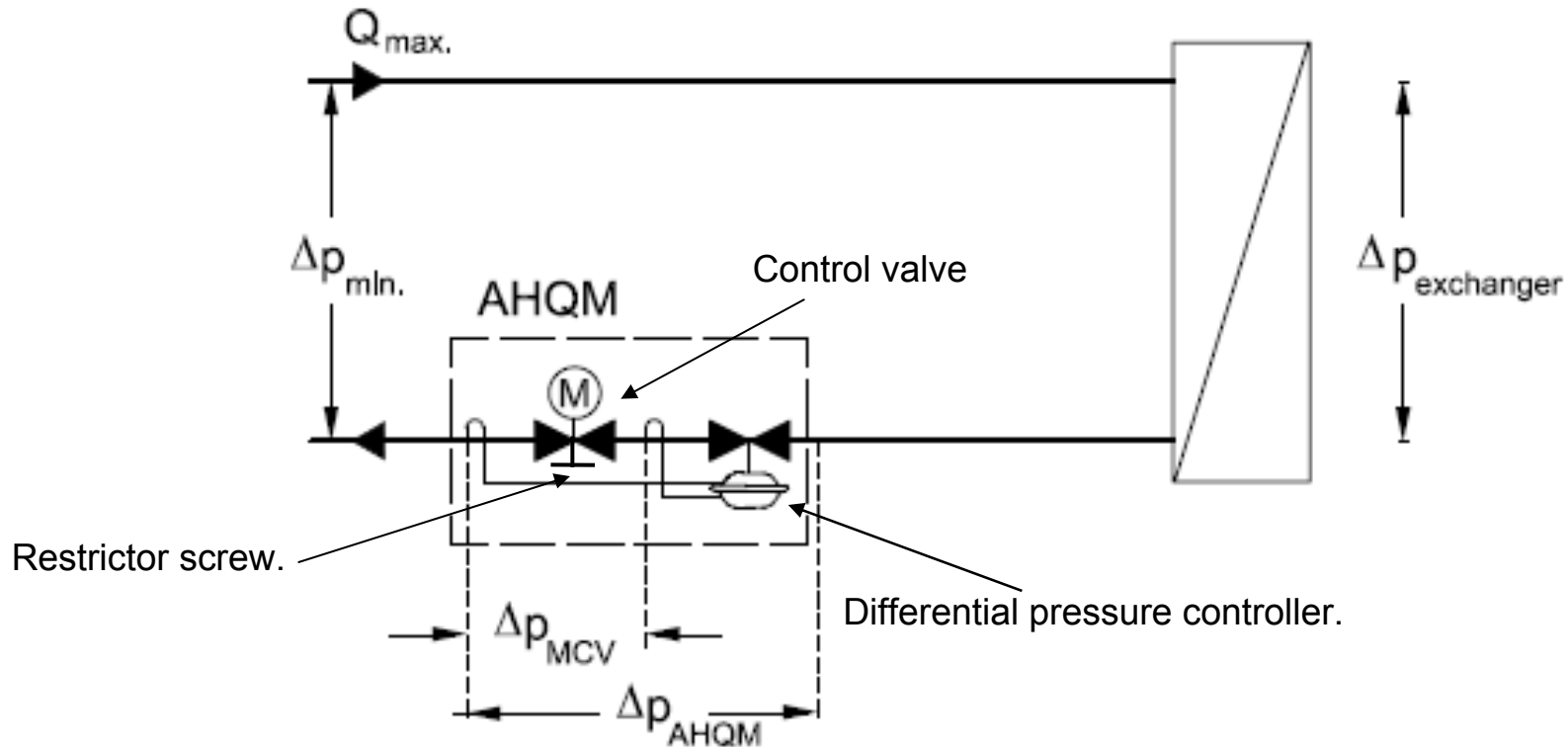

Adjustable restrictor screw

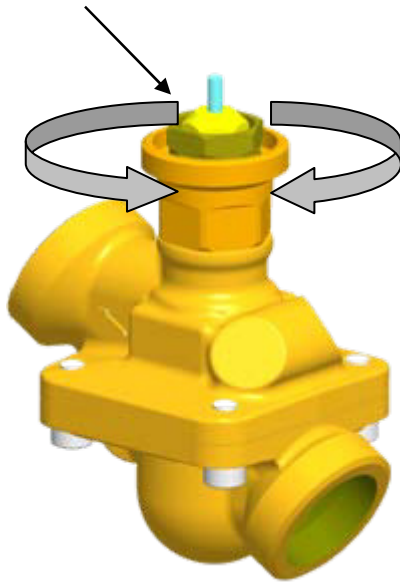

Easy to limit the max flow rate

- It is straight forward to set the design flow.
- Thanks to the flow restrictor screw, the calculated flow can be adjusted easily - without the use of tools.
- Flow can be adjusted by turning the restrictor screw – will not be affected by other factors in the system.
- The Kv value of the valve doesn't need to be calculated anymore.

Main design for AHQM



- No gap between actuator and valve stem in open position.
- Reduce reaction time.

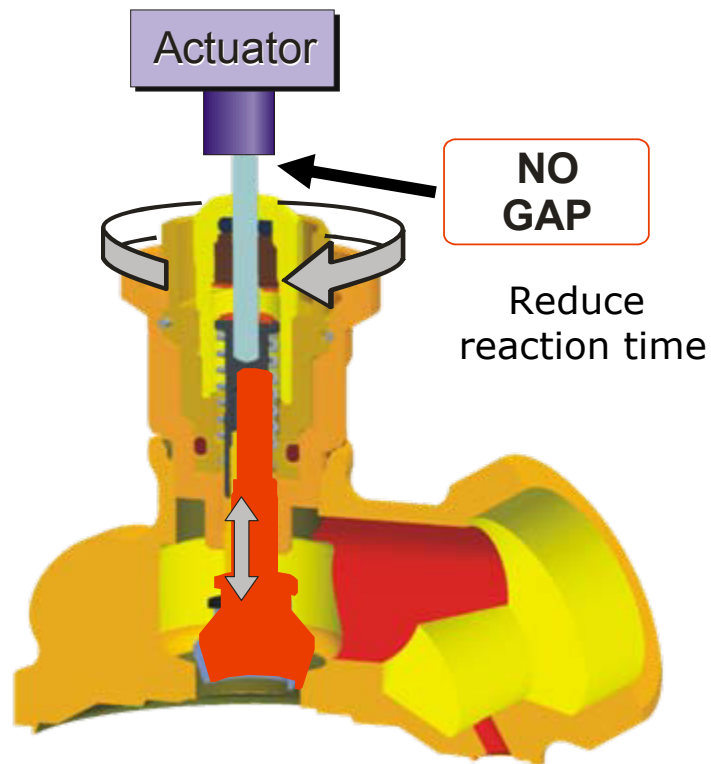

Contents

- Introduction - What is AHQM/AHPBM-F?
- Customer value – Core features & benefits
- How does AHQM work? The design
- Application, system design & installation
- Main technical features & data
- Easy valve selection and dimensioning



Nahrwärme / Block heating / Bio network.

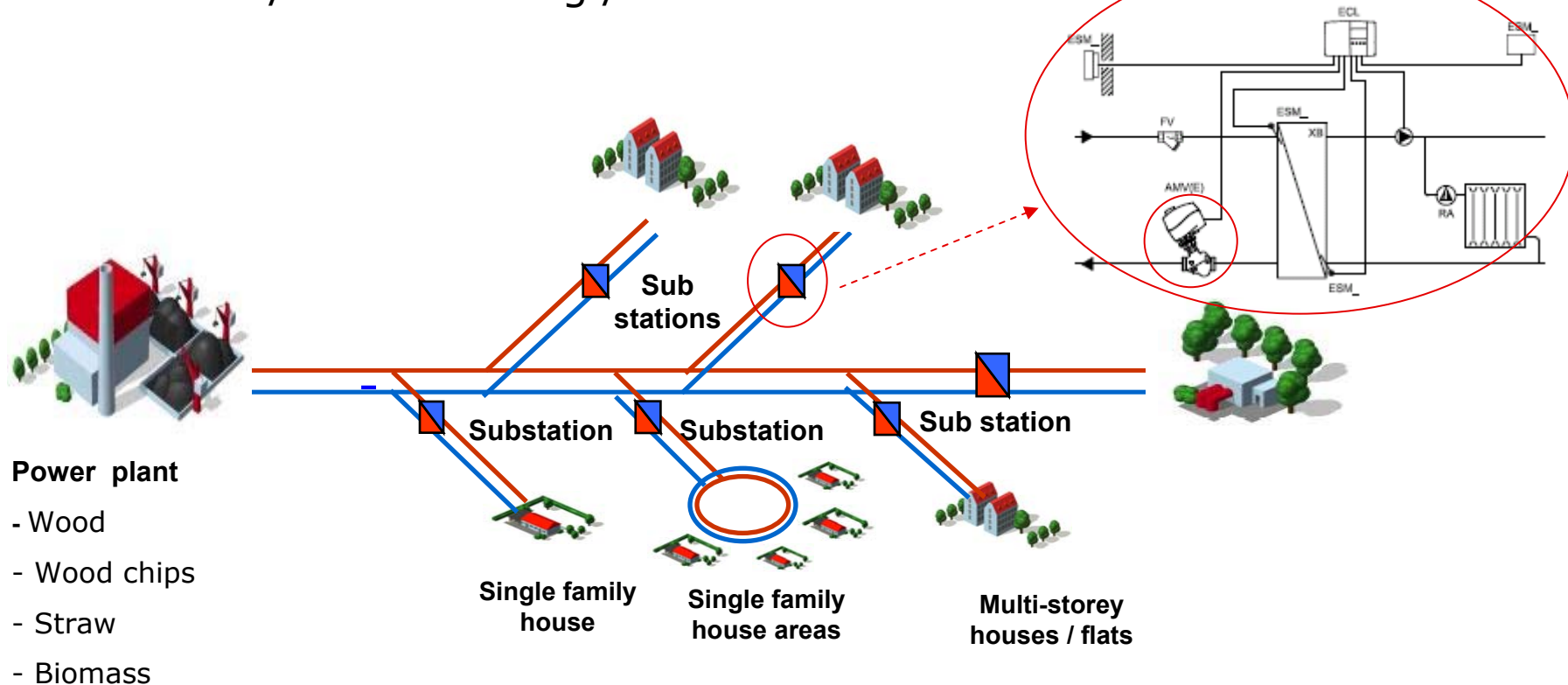

- Supply temperature: Summer 70° / Winter 90 °C (Max. 100° - 120 °C)
- PN10 / 16
- Differential pressure: < 4 bar
- Direct / Indirect connection.

Benefits integrating three basic control functions in one valve

Traditional vs “new” control application:

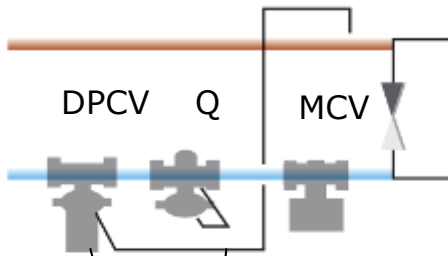

- Differential pressure controller DPCV.
- Motorized control valve MCV.
- Flow limiter Q (DRV).

3 control functions into one valve.

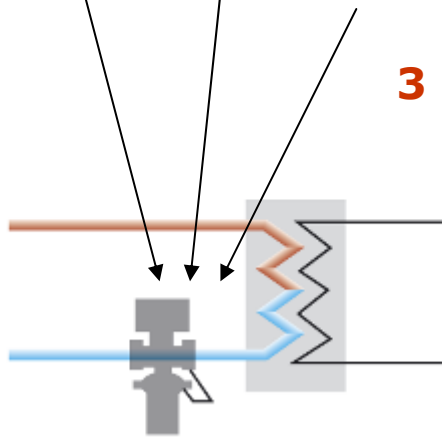

- Multi-functional control valve with
- Differential pressure controller.
 - Flow limiter.
 - Motorized control valve integrated in one valve body.

Multi-functional valve.
type AHQM/AVQM/AFQM

Key benefits

- Reduce initial costs.
- Compact - Smaller built-in dimension
- Low installation costs – only install one valve.
- Full valve authority; $V_a \sim 100\%$

Easy and faster installation

Traditional

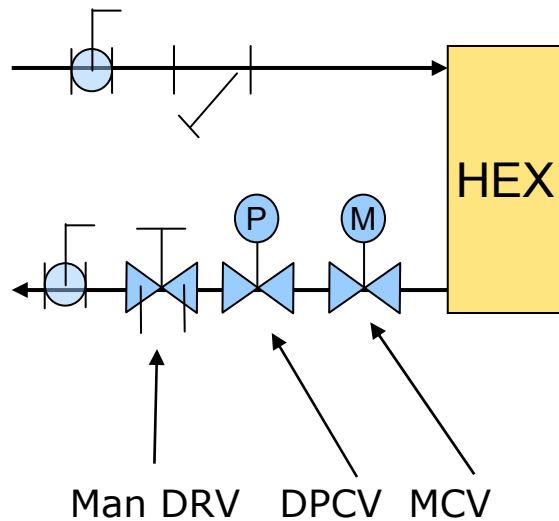

With AHQM

One control valve only, means:

- Faster installation
- Easier commissioning.
- More compact unit and system design.

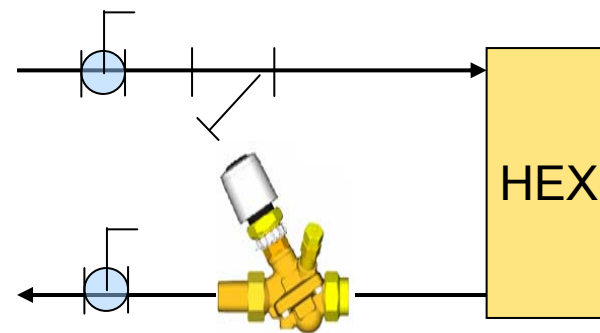

Installation of AHQM

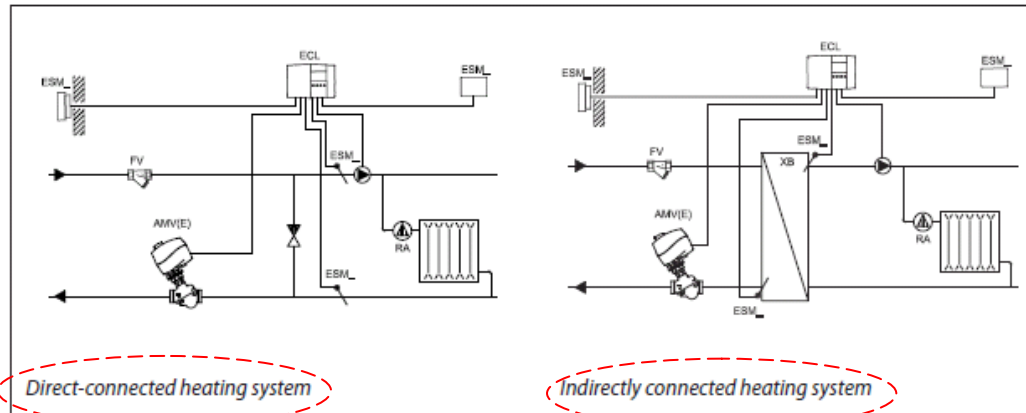

Return mounting

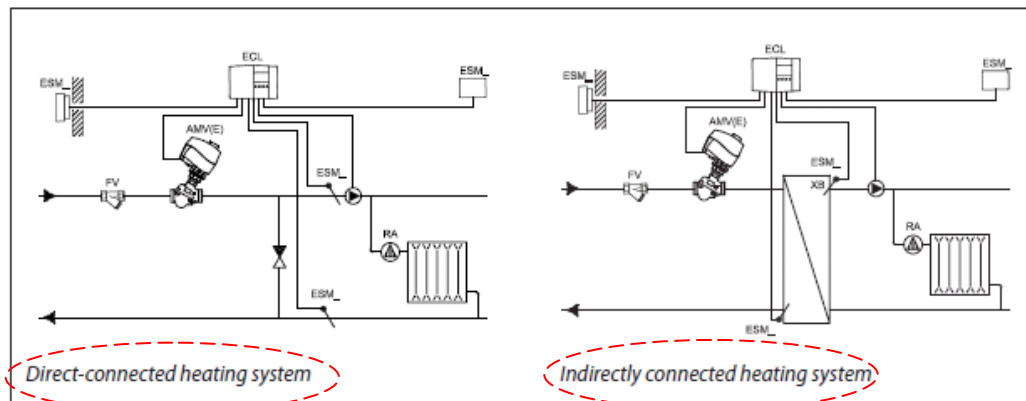

Flow mounting

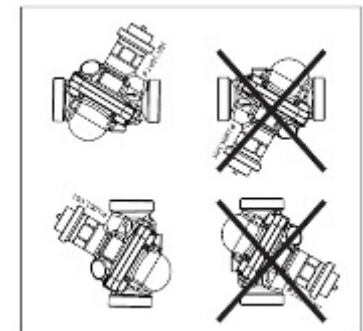

Installation of AHPBM-F

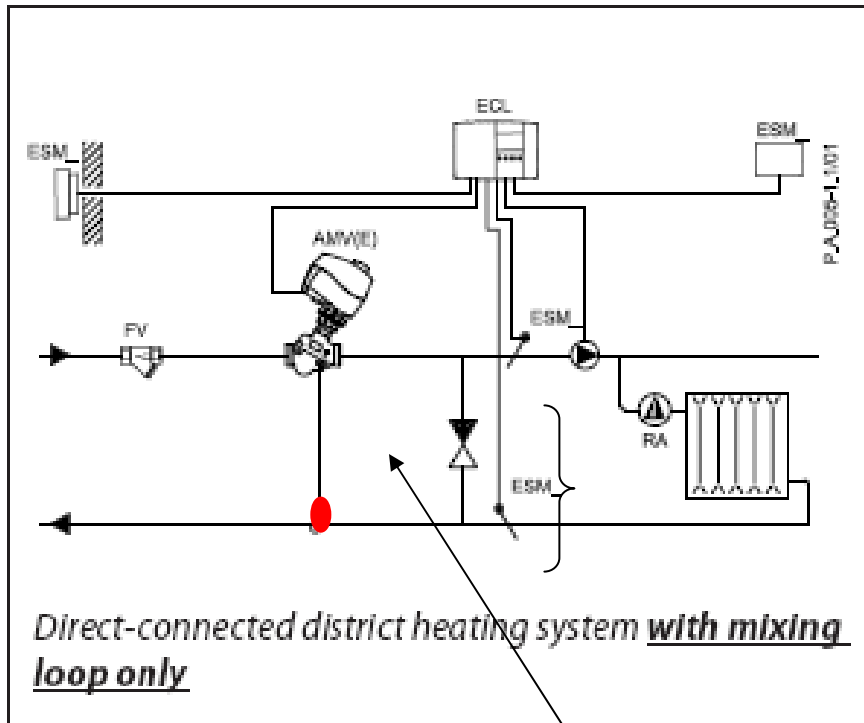

~15 kPa

AHPBM-F is primarily used in direct connected heating system with mixing loop.

It has to be installed in the flow pipe due to the connection of the impulse tube for the differential pressure controller.

Limit the differential pressure across the radiator valves when all radiator valves are in closed position.

Max differential pressure across the radiator valves.
(Pump pressure + 15kPa)

Application - Directly connected – Mixing loop

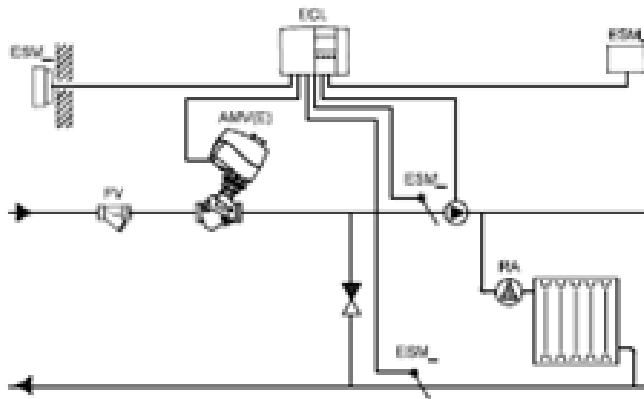

AHQM

Control the mixing temperature in combination with the electronic controller type ECL and limit the max flow rate to the heating circuit.

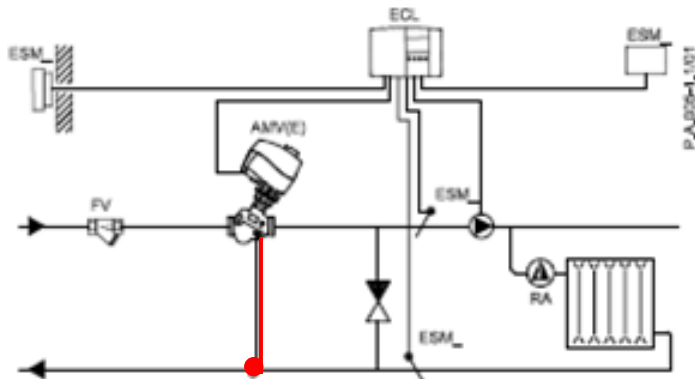

AHPBM-F

Limit the differential pressure across the radiator valves when all radiator valves are in closed position.

Max differential pressure across the radiator valves. (Pump pressure + 15kPa)

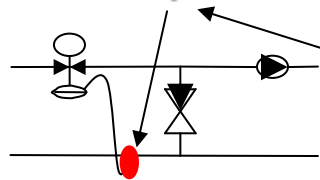

Impulse tube connection.

Flow limitation

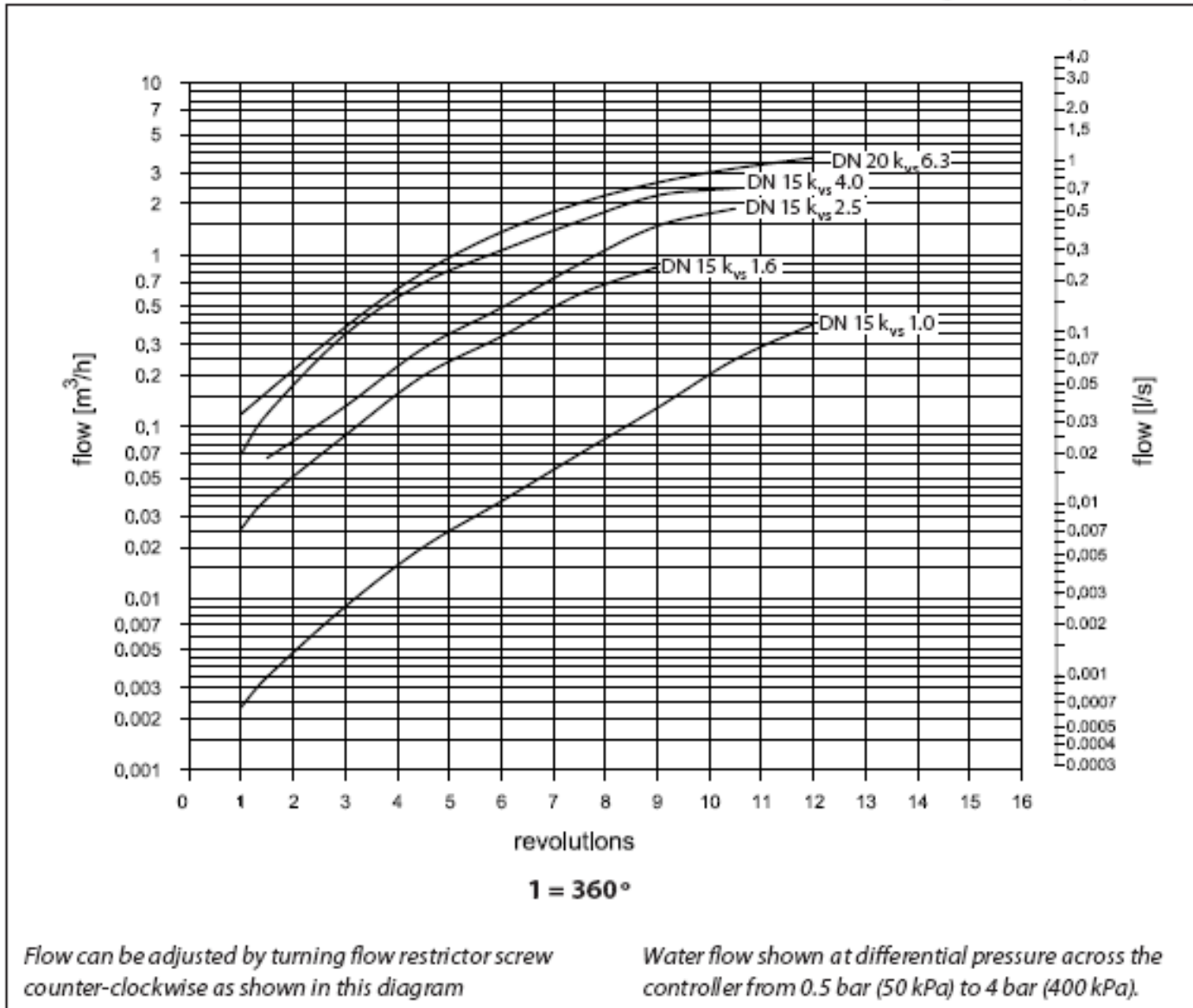

The max flow rate can easily be set by turning flow restrictor screw shown in the diagram.

Contents

- Introduction - What is AHQM/AHPBM-F?
- Customer value – Core features & benefits
- How does AHQM work? The design
- Application, system design & installation
- Main technical features & data
- Easy valve selection and dimensioning



The complete range of AHQM controllers



DN40 -150 are available
from Q1-2010



AHQM



AHQM



AHQM

PN (bar):
DN (mm):
Connection type:
Matr:
Min Δp (bar)
Max Δp (bar)
Max flow (m³/h)
Kvs (m³/h)
Max temp (°C):

16	16	16
15-32	40-50	65-150
Thread	Thread	Flange
DZR Brass	Rg5 (Bronze)	Cast iron
~0,3 bar	~0,4 bar	~0,4 bar
4 bar	4 bar	4 bar
0,4 - 3,4	10- 12	20- 145
1,6-2,5-4-6,3		
120 °C	120 °C	120 °C
Flow / Return. (AMV150) AMV(E) 130/140 AMV(E)13	Flow / Return AMV(E) 15	Flow /Return AMV(E) 15 DN65-100 AMV(E) 55 DN125-150

No safety function !!



AHPBM-F

- AHPBM-F is a self-acting differential pressure controller (fixed setting) with flow limitation and integrated control valve.
- It is primarily for use in direct connected heating systems e.g. with mixing loop.

AHQM/AHPBM-F – Technical data



Nominal pressure:	16 bar
Medium temperature:	2 120 °C
Min. / Max. available differential pressure:	(30 KPa) 50 kPa 400 kPa
Material (valve body / valve seat / valve cone):	Dezincing free brass

AHQM / AHPBM-F	DN (mm)	k_{vs} (m ³ /h)	Q_{min} (m ³ /h)	Q_{nom} (m ³ /h)
	15	1.0	0.035	0.43
		1.25	0.11	0.7
		1.6	0.2	1.0
	20	2.5	0.25	1.2
	25	4.0	0.43	2.2
32	6.3	0.65	3.4	

AHPBM-F has fixed settings	
DN (mm)	Fixed Δp setting (kPa)
15-20	12
25-32	14

Electrical actuators suitable for AHQM/AHPBM-F



AMV(E) 13

14 sec / mm

Actuator with
safety function



AMV(E) 150

24 sec / mm



AMV(E) 130/140 H

24 sec / mm



AHQM / AHPBM-F

Contents

- Introduction - What is AHQM/AHPBM-F?
- Customer value – Core features & benefits
- How does AHQM work? The design
- Application, system design & installation
- Main technical features & data
- Easy valve selection and dimensioning





With the AH-QM, money can be saved in every phase

- Calculation
- Installing
- Commissioning
- In operation



Calculation

- A control valve needs to be able to impose its characteristic to the hydronic circuit.
- To achieve that the resistance in the valve needs to be big enough.



Calculation

Authority =

$$\frac{\Delta p \text{ valve}}{\Delta p \text{ valve} + \cancel{\text{system}}} = 100\%$$

- Because the differential pressure across the AH-QM is constant under all circumstances (Complete open valve to closed valve) the authority is always 100%.
- Therefore the authority doesn't need to be calculated at all!!

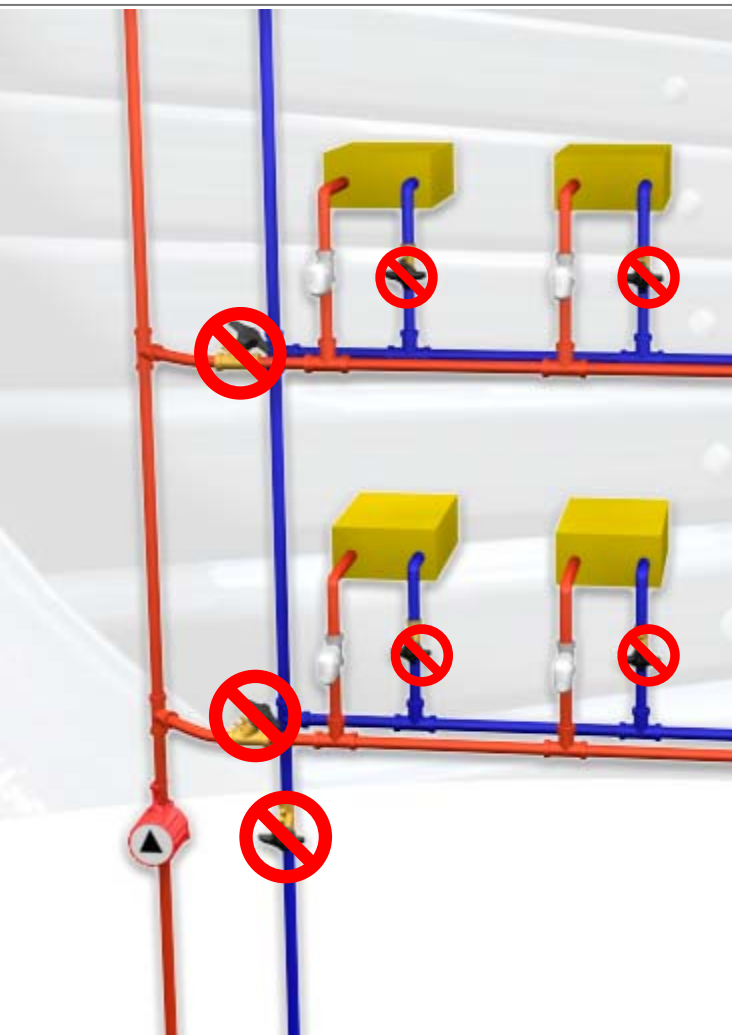

Installation

Savings – An example:

12 x DN 15 (70 min/pcs.) = 840 min

3 X DN 40 (80 min/pcs.) = 240 min

1 X DN 80 (120 min/pcs.) = 120 min

1200 min ~ 20 hours

**For renovation the savings
can be doubled!**

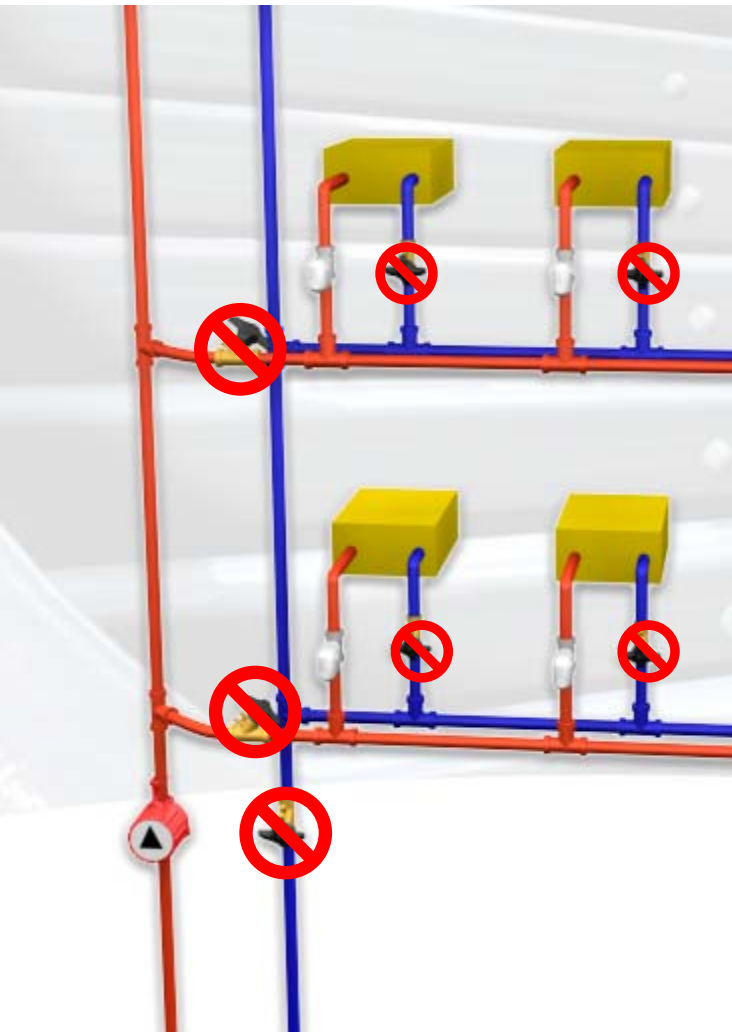

Commissioning

- **Commissioning becomes nearly unnecessary**
(saving of approx. 15 min per valve)
- **No extra organisation or planning needed**
 - Creating 100% load is unnecessary
 - Combine mounting and setting so everything can be finished in one visit can be done by the installer.
- **Phased commissioning**
You don't have to wait with the commissioning until the building is completely finished. Installation can be finished within a shorter time frame.

Savings – An example:
16 valves (15 min/valve.) = 240 min ~4 hours



In operation

- The right flow at all loads
- The control valve always has 100% authority
- Therefore: Always accurate control performance can be achieved.

- Changes do not influence the rest of the installation

Valve selection.

For selection the AH-QM valve only the design flow is needed.

DN	Kvs	Flow range m ³ /h	
		Min.	Max
15	1,0	0,035	0,43
15	1,25	0,11	0,7
15	1,6	0,2	1,0
20	2,5	0,25	1,2
25	4,0	0,43	2,2
32	6,3	0,65	3,4

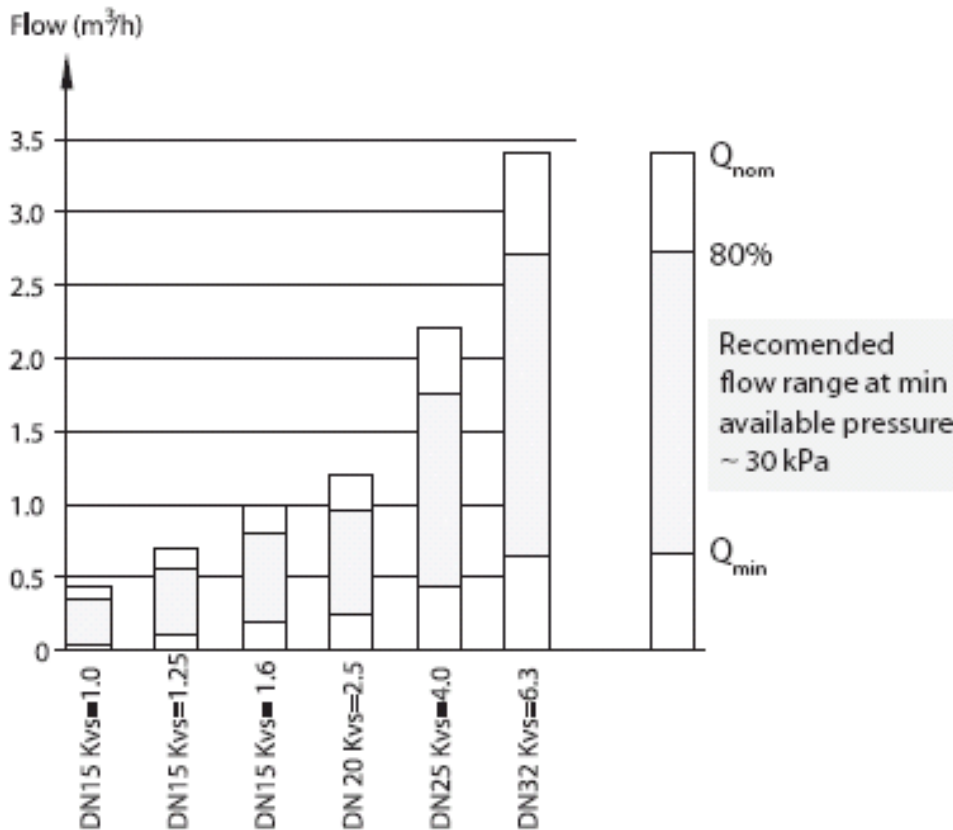

Valve sizing – An example

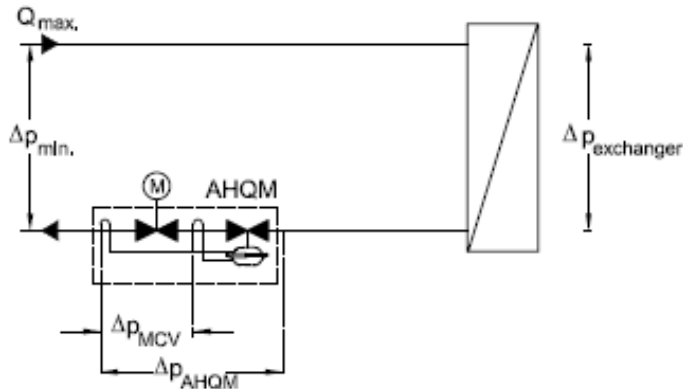

Max flow: 0,55 m³/h
 Pressure drop HEX: 0,1 bar
 Pressure drop in pipes e.g 0,1 bar

Size.
 1) Valve size DN / Kvs.
 2) Flow limitation.
 3) Min. available differential pressure AHQM

Valve

Nominal diameter	DN	15	20	25	32		
k _{vs} value		1.0	1.25	1.6	2.5	4.0	6.3
Q _{min}	m ³ /h	0.035	0.11	0.2	0.25	0.43	0.65
Q _{nom} *		0.43	0.7	1.0	1.2	2.2	3.4

Pressure drop across MCV |----- 0,12 bar -----| -- 0,14 bar --

- 1) DN15 Kvs=1,25 Flow range 0,11 – 0,7 m³/h
- 2) Pre-setting ??

Pre-setting – An example

0,55 m³/h

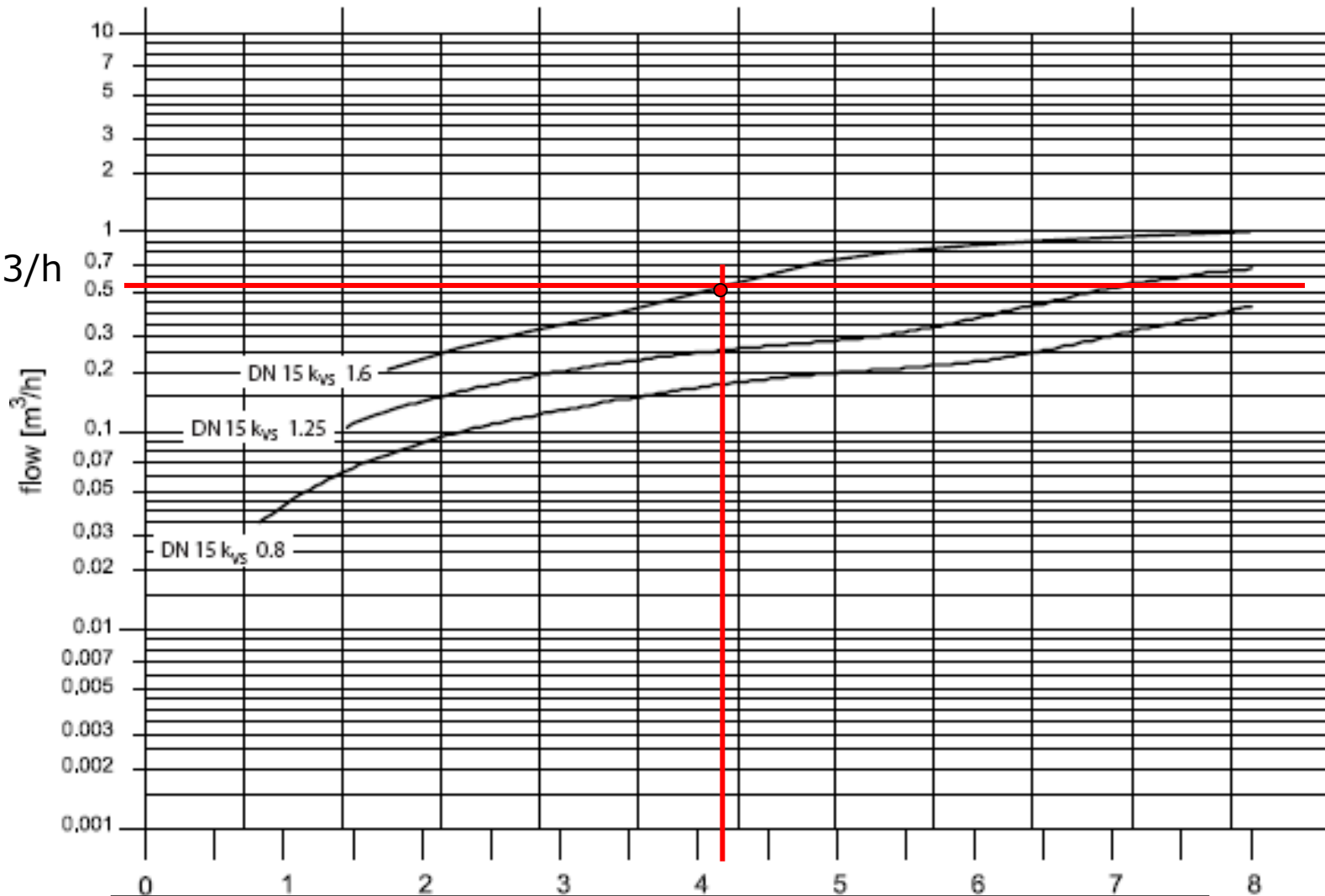

Number of revolution: DN15 K_{vs}=1,25 4,3 revolution.

Valve sizing – An example

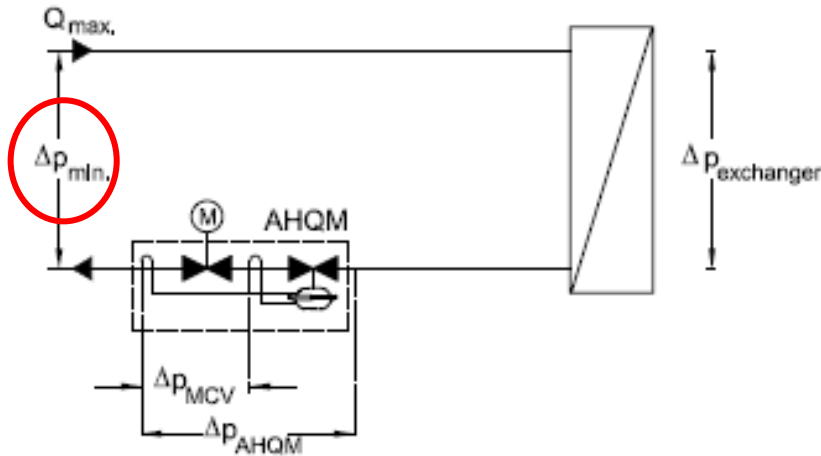

Max flow:	0,55 m ³ /h
Pressure drop - HEX:	0,1 bar
Pressure drop in pipe etc	0,1 bar

- Find.
- 1) Valve size DN / Kvs.
 - 2) Pres setting?
 - 3) Min. diff. available pressure for the substation?

3) Min. diff. pressure for the substation = 0,1 + 0,1 + dP AHQM (bar)

$$\Delta p_{AHQM,MIN} = \left(\frac{Q_{max.}}{k_{vs}} \right)^2 + \Delta p_{MCV}$$

$$dP \text{ AHQM} = (0,55/1,25)^2 + 0,12 = 0,19+0,12=0,31 \text{ bar}$$

$$dP_{min} = 0,31 + 0,1 + 0,1 = 0,51 \text{ bar}$$

EUROHEAT & POWER Guidelines for District Heating Substations



October 2008

Operating and design data

Euroheat & Power strongly recommends DH companies to build all new systems, including new parts in older systems, in accordance with the temperature and pressure levels provided below.

NOTE: Existing systems are not reflected in Table 1 below.

Table 1

District heating system	Operating data	Design data
High-temperature system (HTS system)	100°C; 1,6 MPa differential pressure 0,8 – 0,10 Mpa	110°C; 1,6 MPa
Low-temperature system (LTS system)	Max 85°C; 0,6 MPa differential pressure 0,35 – 0,3 MPa	90°C; 0,6 MPa

One product for multiple applications

- AHQM/AHPBM-F are multi-functional controlles
 - Motorized Control Valve
 - Differential pressure controller
 - Flow limitation
- Compact design gives smaller built-in dimensions
- Low installation costs, since only one valve has to be installed.
- Easy to size and select – only max flow rate are required (available differential pressure has to be verified)
- Easy commissioning/setting the required max. flow. No additional tools are needed.
- Minimum available differential pressure $\sim 0,3$ bar.
- Possible to limit the flow during building period – and then later mount the electrical actuator.
- High valve authority (V_a) $\sim 100\%$ - (Doesn't need to be calculated)





Learn more about Danfoss

www.dh.danfoss.com