

BD350/350GH Direct Current Twin Compressor R134a 24V

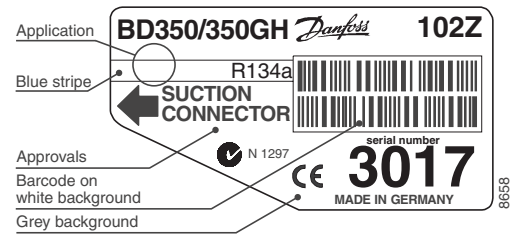

General

Code number (without electronic units)	102Z3017
Electronic unit (2 pcs. required)	single: 101N0710, 36 pcs: 101N0711
Approvals	e4, CE, C-Tick
Compressors on pallet	50

Application

Application		LBP/MBP/HBP
Evaporating temperature	°C	-25 to 15
Voltage range	VDC	19.6-31.5
Max. condensing temperature continuous (short)	°C	60 (70)
Max. winding temperature continuous (short)	°C	125 (135)

- S = Static cooling normally sufficient
- O = Oil cooling
- F₁ = Fan cooling 1.5 m/s
(compressor compartment temperature equal to ambient temperature)
- F₂ = Fan cooling 3.0 m/s necessary
- SG = Suction gas cooling normally sufficient
- = not applicable in this area

Cooling requirements

Application	LBP	MBP	HBP
32°C	S	S	S
38°C	S	S	S
43°C	S	S	S
Remarks on application:			

Motor

Motor type	Variable speed
Resistance, all 3 windings (25°C)	Ω 0.1

Design

Displacement	cm ³	2 x 5.08
Oil quantity (type)	cm ³	560 (polyolester)
Maximum refrigerant charge	g	800
Free gas volume in compressor	cm ³	2 x 1690
Weight - Compressor/Electronic unit	kg	15.8/2 x 0.3

Battery protection settings

Voltage	Min. value	Default	Max. value
Cut out (0.1 steps)	VDC 19.0	21.1	27.0
Cut in diff. (0.1 steps)	VDC 0.5	3.9	10.0

Dimensions

Height	mm	A	173
		B	169
		B1	-
		B2	-
Suction connector	location/I.D. mm angle	C	6.2 90°
Process connector	location/I.D. mm angle	D	6.2 31.5°
Discharge connector	location/I.D. mm angle	E	5.0 28°
Connector tolerance	I.D. mm		±0.09, on 5.0 +0.12/+0.20
Remarks			

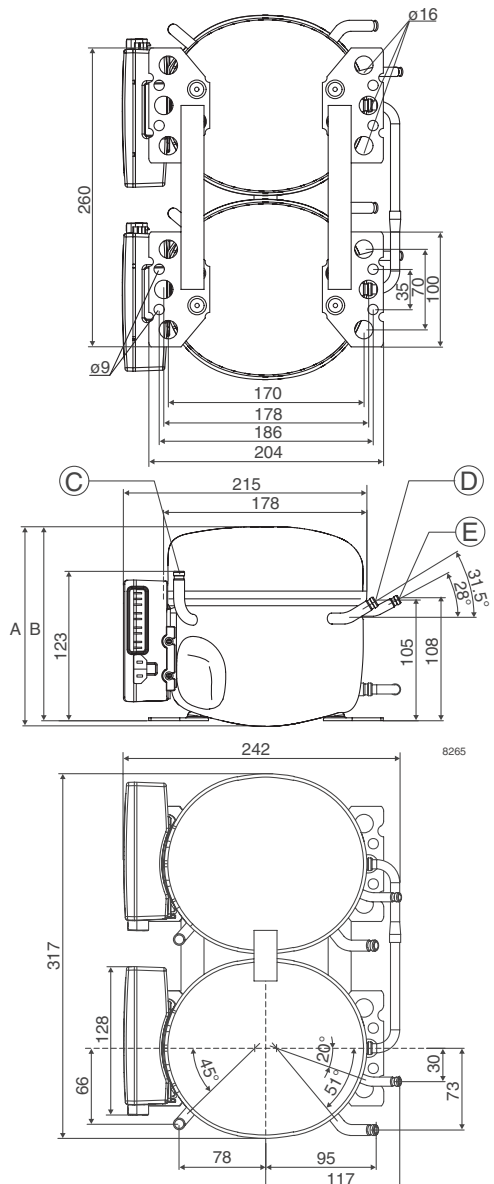

Capacity (EN 12900 Household/CECOMAF)

rpm \ °C	-25	-23.3	-20	-15	-10	-6.7	-5	0	5	7.2	10	15
2,500	169.4	187.4	226	294	376	438	472	584	716	780	868	1040
3,000	202	224	272	352	450	524	566	702	860	936	1042	1250
3,500	228	252	304	396	508	592	638	792	970	1056	1176	1412
4,000	252	278	338	440	564	658	710	880	1080	1176	1308	1572

Capacity (ASHRAE LBP)

rpm \ °C	-25	-23.3	-20	-15	-10	-6.7	-5	0	5	7.2	10	15
2,500	210	232	280	364	466	542	584	726	890	970	1078	1296
3,000	252	278	336	438	558	650	702	870	1068	1164	1296	1558
3,500	282	312	376	492	628	732	790	982	1204	1312	1462	1758
4,000	312	346	418	546	698	814	880	1092	1340	1462	1628	1958

Power consumption

rpm \ °C	-25	-23.3	-20	-15	-10	-6.7	-5	0	5	7.2	10	15
2,500	154.8	163.6	181.6	210	240	260	272	304	336	350	368	400
3,000	191	202	224	258	296	320	334	372	412	430	452	490
3,500	218	230	256	298	342	372	388	434	482	502	528	576
4,000	244	258	288	338	388	424	442	496	552	576	606	660

Current consumption

rpm \ °C	-25	-23.3	-20	-15	-10	-6.7	-5	0	5	7.2	10	15
2,500	6.46	6.82	7.56	8.76	10.02	10.86	11.32	12.64	14.00	14.58	15.34	16.66
3,000	7.96	8.40	9.32	10.78	12.30	13.34	13.90	15.52	17.16	17.88	18.80	20.42
3,500	9.04	9.58	10.68	12.42	14.24	15.50	16.16	18.10	20.06	20.92	22.02	23.96
4,000	10.14	10.76	12.04	14.06	16.20	17.64	18.40	20.68	22.96	23.98	25.26	27.50

COP (EN 12900 Household/CECOMAF)

rpm \ °C	-25	-23.3	-20	-15	-10	-6.7	-5	0	5	7.2	10	15
2,500	1.09	1.15	1.25	1.40	1.56	1.68	1.74	1.93	2.13	2.23	2.36	2.60
3,000	1.06	1.11	1.21	1.37	1.53	1.64	1.70	1.88	2.09	2.18	2.31	2.55
3,500	1.05	1.09	1.19	1.33	1.48	1.59	1.65	1.82	2.01	2.10	2.22	2.45
4,000	1.03	1.08	1.17	1.31	1.45	1.55	1.61	1.77	1.96	2.05	2.16	2.38

COP (ASHRAE LBP)

rpm \ °C	-25	-23.3	-20	-15	-10	-6.7	-5	0	5	7.2	10	15
2,500	1.36	1.42	1.55	1.74	1.95	2.09	2.17	2.40	2.67	2.79	2.95	3.27
3,000	1.32	1.38	1.51	1.70	1.90	2.04	2.12	2.35	2.61	2.73	2.89	3.20
3,500	1.30	1.36	1.48	1.66	1.85	1.98	2.05	2.27	2.52	2.63	2.79	3.08
4,000	1.28	1.34	1.45	1.62	1.81	1.93	2.00	2.22	2.45	2.56	2.71	2.99

Operational errors

Error code	Error type
	Can be read out in the software Tool 4 Cool™ .
6	Thermostat failure (If the NTC thermistor is short-circuit or has no connection, the electronic unit will enter manual mode).
5	Thermal cut-out of electronic unit (If the refrigeration system has been too heavily loaded, or if the ambient temperature is high, the electronic unit will run too hot).
4	Minimum motor speed error (If the refrigeration system is too heavily loaded, the motor cannot maintain minimum speed at approximately 1,850 rpm).
3	Motor start error (The rotor is blocked or the differential pressure in the refrigeration system is too high).
2	Fan over-current cut-out (The fan loads the electronic unit with more than 1.8A _{peak}).
1	Battery protection cut-out (The voltage is outside the cut-out setting).

Wire Dimensions

Cross section [mm ²]	Size		Max. length* 24V operation	
	AWG [Gauge]	[m]	[ft.]	
2 x 4	11	1.5	4.92	
2 x 6	9	2	6.60	
2 x 10	7	4	13.12	

*Length between battery and electronic unit

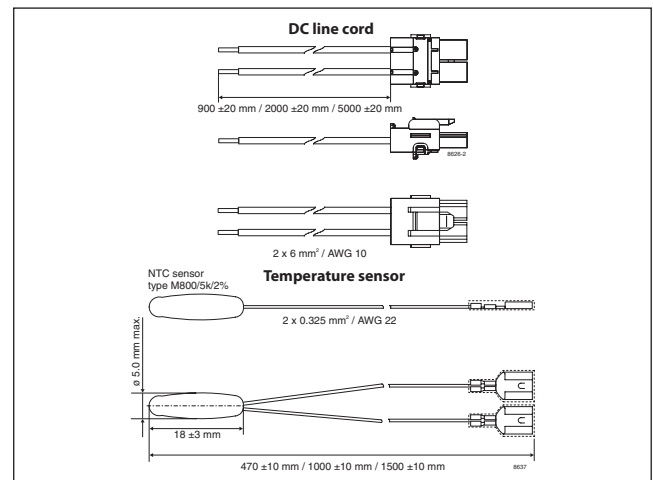
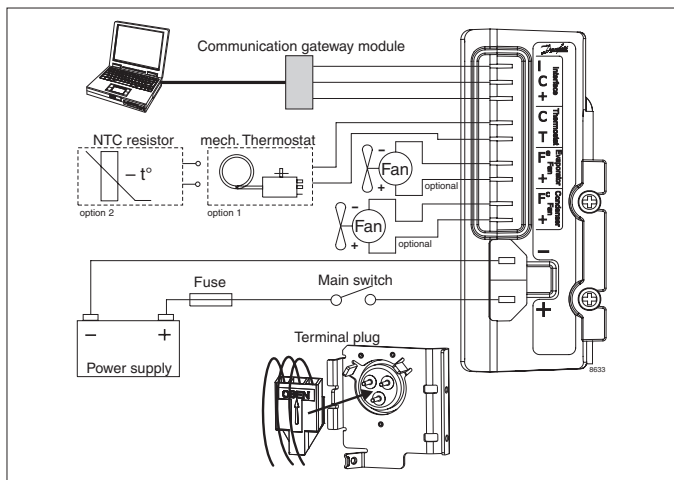

Accessories for one BD350GH	Single pack	I - Pack
DC line cord, 900 mm	105N9542	105N9543, 36 pcs
DC line cord, 2000 mm	105N9540	105N9541, 36 pcs
DC line cord, 5000 mm	105N9538	105N9539, 36 pcs
Temperature sensor 470 mm	105N9612	105N9613, 200 pcs.
Temperature sensor 1000 mm	105N9614	105N9615, 100 pcs.
Temperature sensor 1500 mm	105N9616	105N9617, 100 pcs.
Communication cable 1500 mm	-	105N9545, 100 pcs.
Communication cable 3000 mm	-	105N9547, 50 pcs.
Communication gateway module	105N9501	-

Note: each fan max. 40W

Test conditions	EN 12900/CECOMAF	ASHRAE
Condensing temperature	55°C	54.4°C
Ambient temperature	32°C	32°C
Suction gas temperature	32°C	32°C
Liquid temperature	no subcooling	32°C

Accessories for	BD350/350GH	Code number
Bolt joint for one compressor	Ø: 16 mm	118-1917
Bolt joint in quantities	Ø: 16 mm	118-1918
Snap-on in quantities	Ø: 16 mm	118-1919
Standard automobile fuse DIN 7258	24V: 30A	Not deliverable from Danfoss
Main switch	rated to min. 50A	

Danfoss can accept no responsibility for possible errors in catalogues, brochures and other printed material. Danfoss reserves the right to alter its products without notice. This also applies to products already on order provided that such alterations can be made without consequential changes being necessary in specifications already agreed. All trademarks in this material are property of the respective companies. Danfoss and the Danfoss logotype are trademarks of Danfoss A/S. All rights reserved.