

Data sheet

# Oil Motor Pump type BFPM 21

## Application

The BFPM range is a series of Danfoss oil pumps in combination with a highly efficient permanent magnet motor.

The BFPM Electronic Controller must be used for controlling BFPM motor pumps (see separate data sheet for BFPM Electronic Controller).

**BFPM 21** is designed for small domestic oil burners up to 24 l/h.

### BFPM 21 features:

- Light oil and kerosene
- 1- or 2-pipe operation
- 1-stage
- Built-in pressure regulator
- Solenoid valve cut-off
- Cartridge filter

## Function

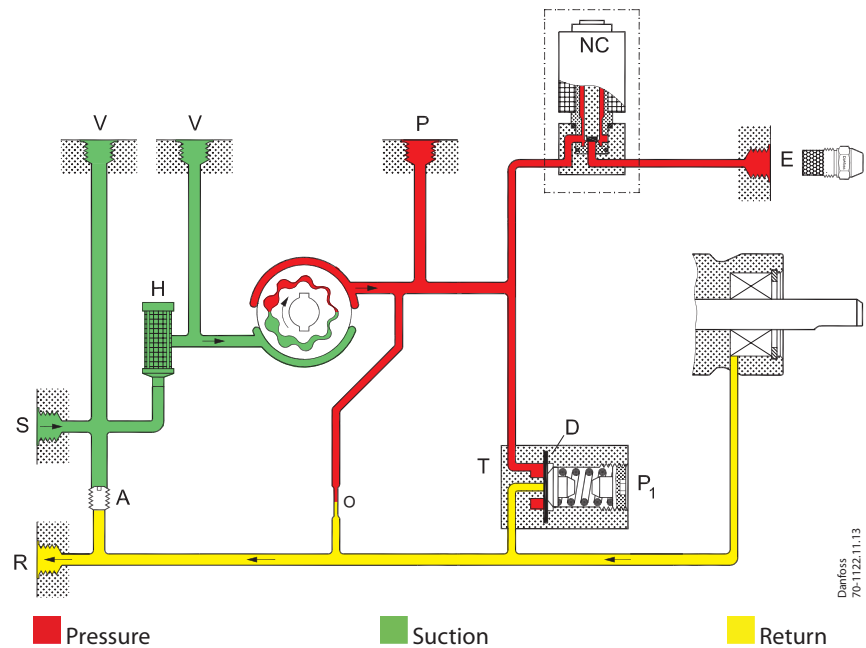

From the suction inlet (S) oil is drawn through the filter (H) to the gear set, where the pressure is increased. When voltage is applied to the NC-valve, it opens and releases oil to the nozzle outlet.

By means of the diaphragm (D) in the pressure regulator (T), the pressure is kept constant at the value set on adjustment screw (P1).

In 2-pipe systems the excess oil is led back to the return outlet (R) and the tank.

In 1-pipe systems with plugged return outlet (R) and screw (A) removed, the oil is returned internally to the gear set (see figure).

### Cut-off function, solenoid valve

When the burner stops, the voltage to the NC-valve is cut off and the oil flow to the nozzle outlet is cut off immediately.

### Bleeding

In 2-pipe systems the pump is self-priming, i.e. bleeding is performed via the constriction (O) to the return outlet (R).

In 1-pipe systems with plugged return outlet (R), bleeding must be performed through the nozzle outlet (E) or the pressure gauge port (P).

### Warranty

For pumps used outside the stated technical data and used with oil containing abrasive particles Danfoss cannot give any warranty.

*Note! The solenoid valve must be replaced after 250.000 operations or 10 years (approved life expectancy).*

Identification

<b>BFPM</b>	2	1	L	3	L	
						<b>L:</b> left hand nozzle outlet
						<b>3:</b> capacity 24 l/h
						<b>L:</b> left hand rotation
						<b>1:</b> with one solenoid valve
					<b>2:</b> cartridge filter, pressure adjustment on front	

Nozzle capacity at 4.3 cSt., 10 bar, 2800 min<sup>-1</sup>

Technical Data

Oil types	Standard fuel gas oil and fuel gas oil acc. to DIN V 51603-6 EL A Bio-10 (Max. 10% FAME)
Viscosity range (measured in suction inlet)	(1.3) 1.8 to 12.0 cSt. (mm <sup>2</sup> /s)
Filter area/mesh	11 cm <sup>2</sup> /200 μm
Pressure range <sup>1)</sup>	7 to 20 bar
Default setting	10 ±1 bar
Max. pressure in suction inlet/return outlet	2 bar
Speed	400 to 3400 min <sup>-1</sup>
Ambient/transport temperature	-20 to +70° C
Temperature of medium	0 to +70° C
Power supply/drive BFPM motor <sup>2)</sup>	230 V switched from controller
Coil power consumption	9 W
Coil rated voltage (other voltages on request)	220/240V, 50/60 Hz
Coil enclosure	IP 40

<sup>1)</sup> Max. 12 bar at 1.3 cSt., max. 15 bar at 1.8 cSt.

<sup>2)</sup> Warning: Do not connect BFPM motor directly to 230 V/50 Hz power supply!

Nozzle capacity

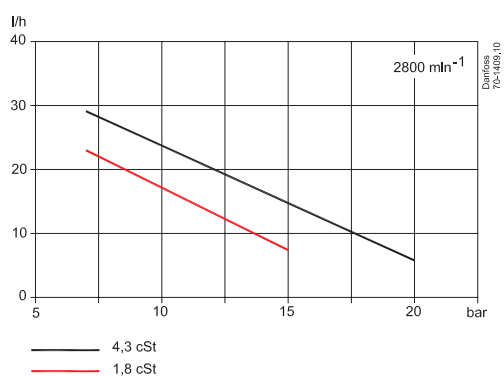

Power consumption

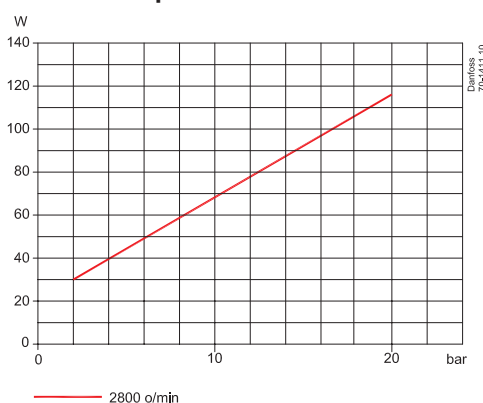

Connections

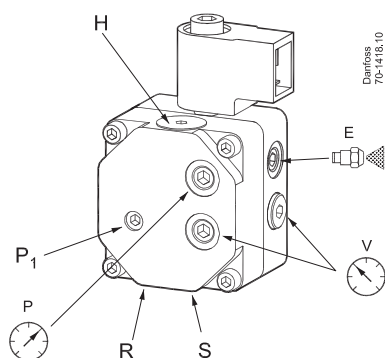

Danfoss  
70-4418.10

- P<sub>1</sub>**: Pressure adjustment
- S**: Suction inlet G1/4
- R**: Return outlet G1/4
- E**: Nozzle outlet G1/8
- P**: Pressure gauge port G1/8
- V**: Vacuum gauge port G1/8
- H**: Filter

Change-over and Filter Replacement

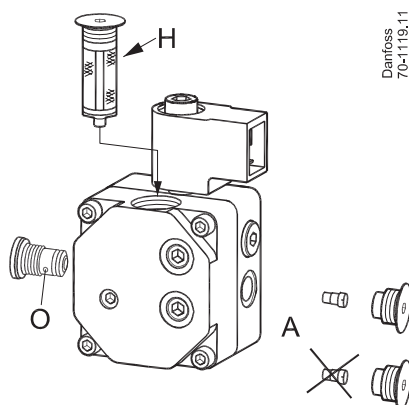

Danfoss  
70-11119.11

- H**: Filter
- A**: 2-pipe operation, with screw
- B**: 1-pipe operation, without screw

Dimensions

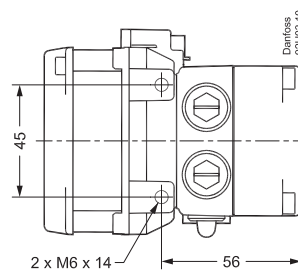

Danfoss  
92U03.10

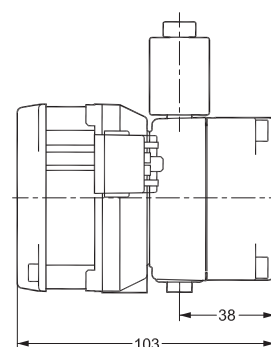
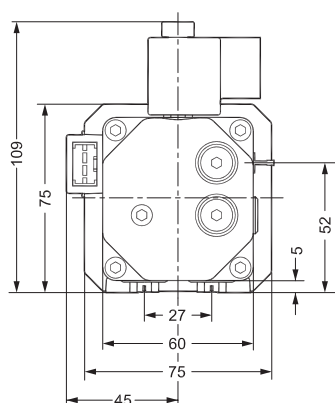

Mounting

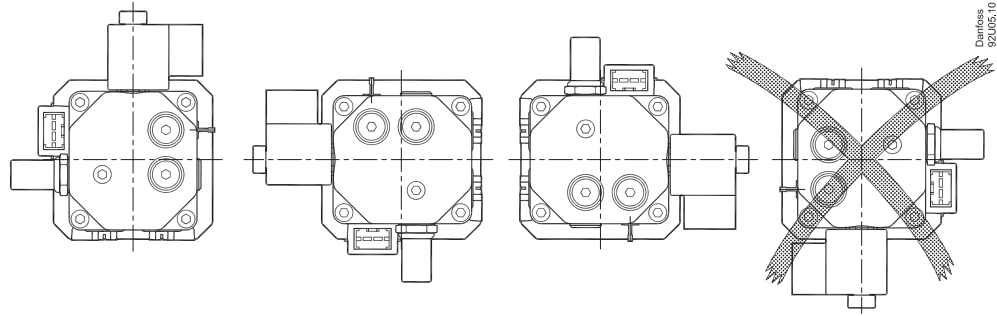

Danfoss  
92U05.10

Additional documentation on burner components is available on <http://heating.danfoss.com/>

**Danfoss A/S**

Heating Segment • [heating.danfoss.com](http://heating.danfoss.com) • +45 7488 2222 • E-Mail: [heating@danfoss.com](mailto:heating@danfoss.com)

Danfoss can accept no responsibility for possible errors in catalogues, brochures and other printed material. Danfoss reserves the right to alter its products without notice. This also applies to products already on order provided that such alterations can be made without subsequential changes being necessary in specifications already agreed. All trademarks in this material are property of the respective companies. Danfoss and all Danfoss logotypes are trademarks of Danfoss A/S. All rights reserved.