

Data Sheet

H1-The new Generation of Hydrostatics

250 cm³ Bent Axis Variable Motor

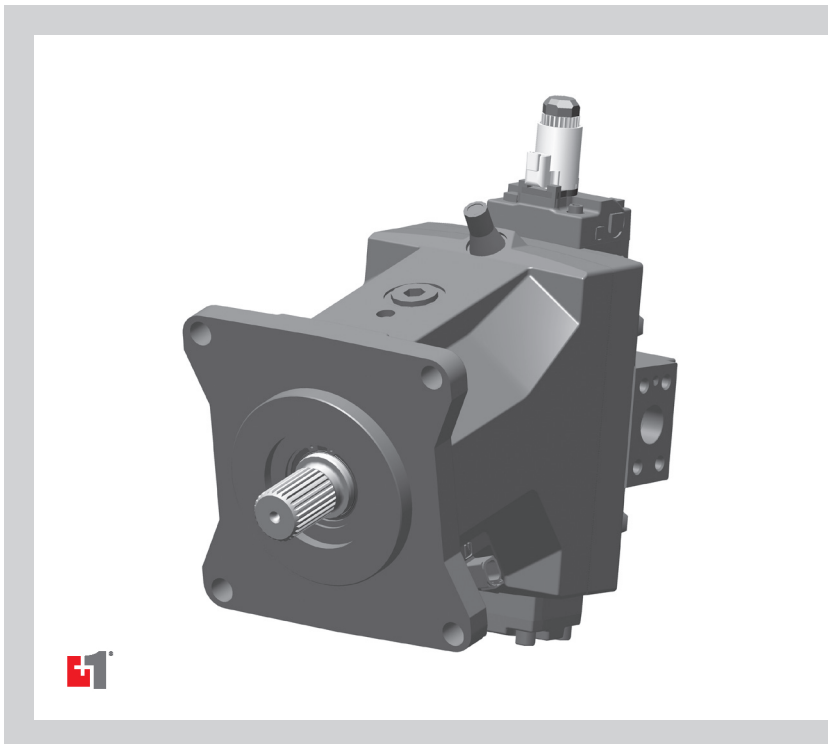

For more than 40 years, Danfoss has been developing state-of-the-art components and systems for mobile machinery used in off-highway operations around the world.

We have become a preferred supplier by offering the best of what really matters: The hardware inside your vehicle application.

H1 - our new generation of servo-controlled hydrostatic pumps and bent axis variable motors is no exception.

The H1 product is built around an advanced control and available in a wide range of displacements. It is designed for quality and reliability and offers expanded functionality, greater total efficiency, and easy installation.

All H1 control and sensor options are PLUS+1[®] Compliant. PLUS+1[®] allows you to rapidly develop and customize electronic machine control. It opens up the future by combining machine controls and diagnostics in an integrated operating network.

Features

- **Designed for quality and reliability**
 - Proven and optimized 9 piston rotating group
 - Single piece housing
 - Electric components with IP67 & IP69K rating
- **Installation and packaging benefits**
 - Optimized for shortest length
 - Standardized connector interface
 - Integrated loop flushing device
 - Radial or axial high pressure ports
- **Wide range of controls**
 - Electric Two-position Control
 - Electric Proportional Control
 - Hydraulic Two-position Control
 - Hydraulic Proportional Control
 - Pressure Compensator Override
 - Proportional Pressure Compensator Override
 - Brake Pressure Defeat option
- **Expanded functionality**
 - Zero degree capability together with a high performance 32 degree maximum angle
 - Enhanced control functions with proportional controls de-energized at minimum or maximum displacement
 - Optional integrated speed sensor with
 - Dual redundant speed sensing
 - Direction indication
 - Temperature sensing
 - Wire fault detection
- **Greater total efficiency**
 - Minimized losses
 - Improved at high flow conditions
- **Common controls across the entire motor family**
 - PLUS+1[®] Compliant control and sensor options

Technical specifications

Physical Properties

Features	Units	Size 250	
Displacement	cm ³ [in ³]	250 [15.25]	
Weight (with Electric Proportional Control)			
SAE ISO 3019/1	kg [lb]	87.7 [193]	
Operating Parameters			
Output Speed min-1 [rpm]	Rated	at max. displacement	2200
		at min. displacement (6°)	3650
		at 0° displacement	4050
	Maximum	at max. displacement	2800
		at min. displacement (6°)	4500
System Pressure bar [psi]	Working	450 [6527]	
	Maximum	480 [6960]	
	Min. low loop	7.5 [109]	
Case Pressure bar [psi]	Rated	3 [44]	
	Maximum	5 [73]	
	Minimum	0.3 [4]	

Schematic (example)

Electric Proportional Control

(de-energized = max. displacement)

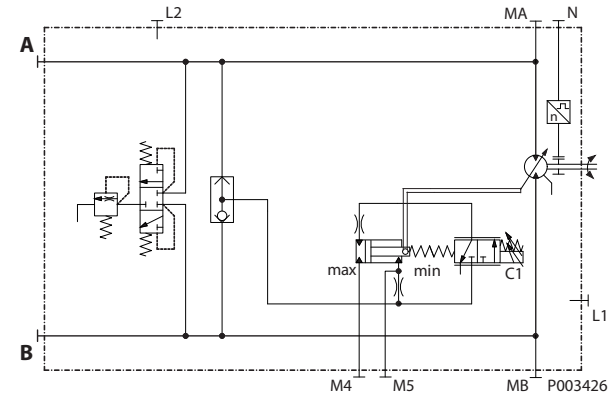

Installation Drawings

SAE ISO 3019/1 with Electric Proportional Control (de-energized = max. displacement)

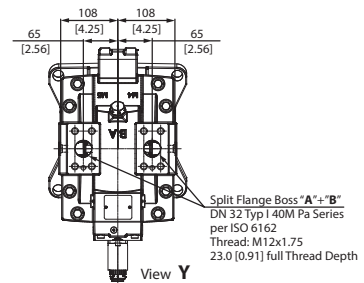
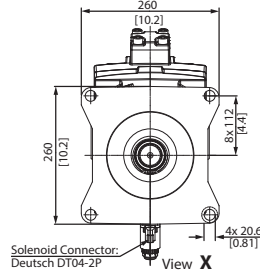
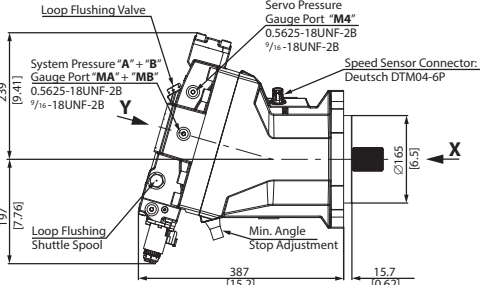

SAE ISO 3019/1 with Electric Proportional Control (de-energized = min. displacement)

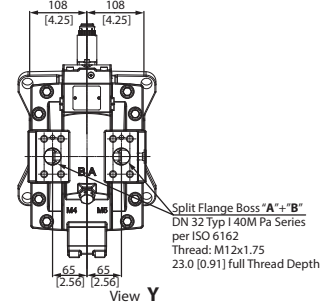
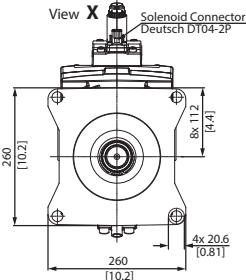
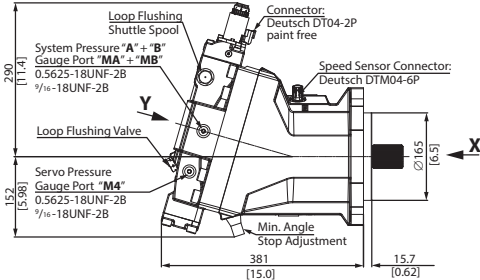

SAE ISO 3019/1 with Electric Two-Position Control (de-energized = min. displacement) Pressure Compensator Override, Brake Pressure Defeat

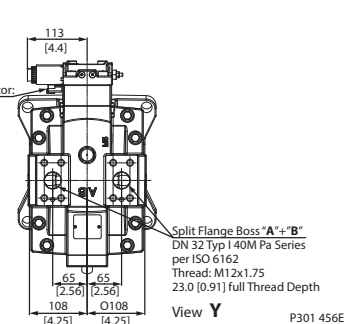
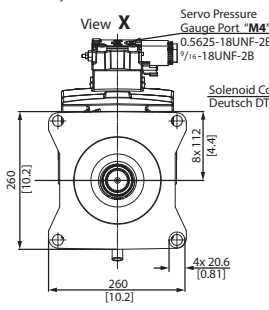
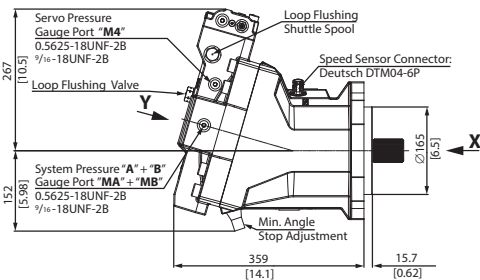

Danfoss Power Solutions (US) Company
2800 East 13th Street
Ames, IA 50010, USA
Phone: +1 515 239 6000

Danfoss Power Solutions GmbH & Co. OHG
Krokamp 35
D-24539 Neumünster, Germany
Phone: +49 4321 871 0

Danfoss Power Solutions ApS
Nordborgvej 81
DK-6430 Nordborg, Denmark
Phone: +45 7488 2222

Danfoss Power Solutions Trading (Shanghai) Co., Ltd.
Building #22, No. 1000 Jin Hai Rd
Jin Qiao, Pudong New District
Shanghai, China 201206
Phone: +86 21 3418 5200

Danfoss can accept no responsibility for possible errors in catalogues, brochures and other printed material. Danfoss reserves the right to alter its products without notice. This also applies to products already on order provided that such alterations can be made without changes being necessary in specifications already agreed. All trademarks in this material are property of the respective companies. Danfoss and the Danfoss logotype are trademarks of Danfoss A/S. All rights reserved.