

Data sheet

APP Pumps

APP 53 / APP 65 / APP 78 / APP 86 / APP 92

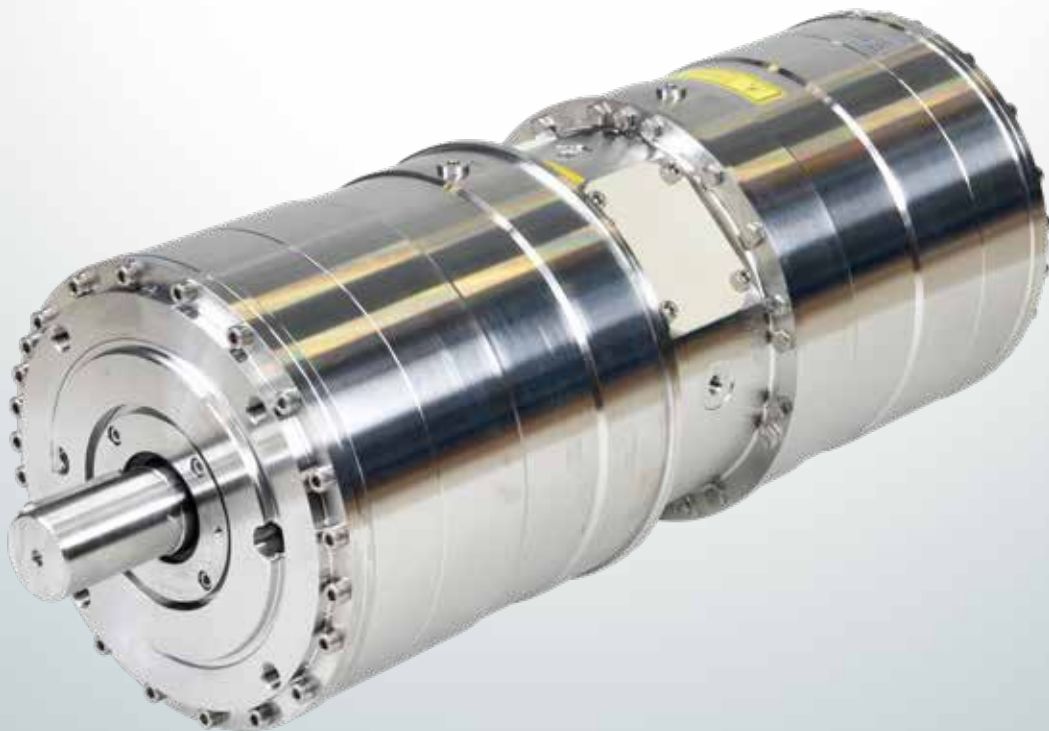

Table of Contents	1.	Introduction	3
	2.	Benefits.....	3
	3.	Application examples	3
	4	Technical data	4
	4.1	APP 53-92.....	4
	5.	Performance curves.....	6
	5.1	APP 53 flow at different rpm.....	6
	5.2	APP 65 flow at different rpm.....	7
	5.3	APP 78 flow at different rpm.....	8
	5.3	APP 86 flow at different rpm.....	9
	5.4	APP 92 flow at different rpm.....	10
	6.	Flushing valve curves	11
	6.1	APP 53-92 integrated flushing valve	11
	7.	Motor requirements.....	11
	7.1	Calculation factor at 60 barg / 870 psig for APP 53-92	11
	8.	Temperature and corrosion.....	12
	8.1	Operation.....	12
	9.	Installation.....	12
	9.1	Filtration.....	13
	9.2	RO system with direct supply:	13
	10.	Dimensions and connections.....	15
	10.1	APP 53.....	15
	10.2	APP 65 - 92.....	16
	10.3	APP 53-92 with IE3 motor 110 kW.....	18
	10.4	APP 53-92 with IE3 motor 132 kW.....	18
	10.5	APP 53-92 with IE3 motor 160 kW.....	19
	10.6	APP 53-92 with IE3 motor 200 kW.....	19
	11.	Pump connections	20
	11.1	APP 53 - 92.....	20
	12.	VCM 3" Victaulic.....	21
	12.1	Technical data	21
	12.2	Flow versus pressure	22
	13.	Accessories	23
	14.	Service and warranty.....	23

1. Introduction

The Danfoss range of APP high-pressure pumps is designed according to EN 809 for use in RO applications with low viscosity and corrosive fluids such as sea water.

Danfoss APP pumps are positive displacement pumps with axial pistons that move a fixed amount of water in each cycle. Flow is proportional to the number of input shaft revolutions (rpm).

Unlike centrifugal pumps, they produce the same flow at a given speed no matter what the discharge pressure.

The sectional drawing below illustrates the main components of the APP 53-92 pump range.

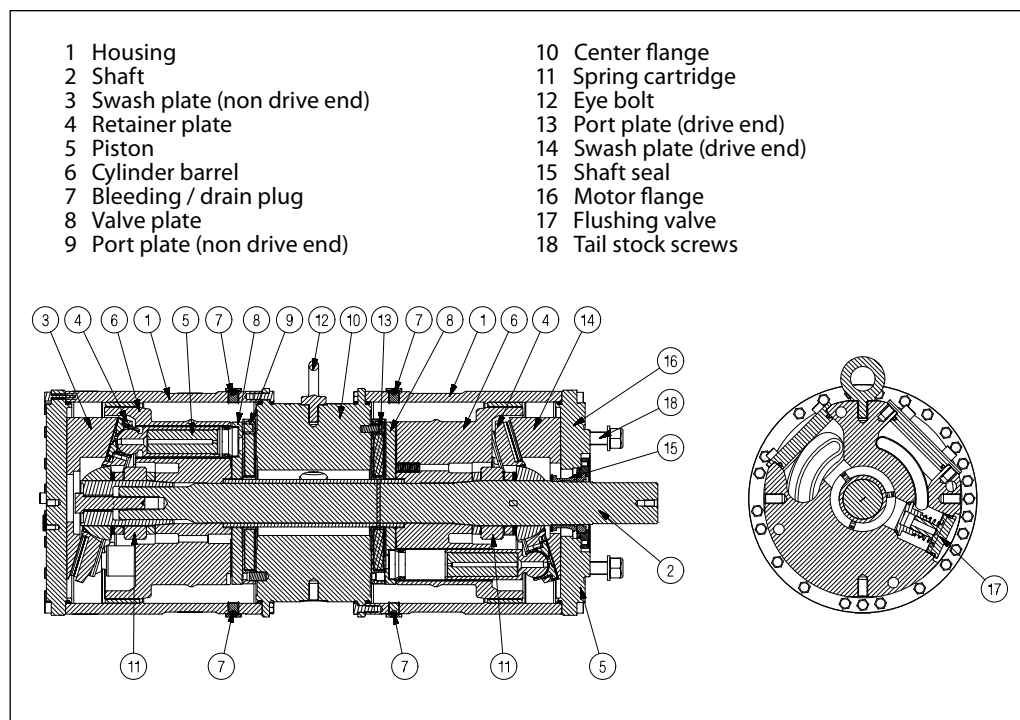

2. Benefits

- **Zero risk of lubricant contamination:**
 - Oil lubricants are replaced with the pumped medium, water, so there is no contamination risk from the pump.
- **Low maintenance costs:**
 - Efficient design and all-stainless steel construction ensure exceptionally long life. When Danfoss specifications are met, service intervals of 8,000 hours can be expected. Service is easy, and can be carried out on-site due to the simple design and few parts.
- **Low energy costs:**
 - The highly efficient axial piston design provides the lowest energy consumption of any comparable pump on the market.
- **Easy installation:**
 - The most compact and lightest design available.
 - The pump can be installed horizontally in different positions rotating it around the shaft (see section 10 for example).
- **High reliability:**
 - No pulsation dampeners necessary due to extremely low pressure pulsation.
 - Powered directly by electric motors or combustion engines (with special coupling).
 - All pumps are supplied with an integrated flushing valve that allows the fluid to flow from inlet to the outlet, when the pump is not running.
- **Certified quality:**
 - All parts are made of high corrosion resistant materials e.g. Duplex (EN1.4462/ UNS S31803) and Super Duplex (EN1.4410/UNS S32750) stainless steel and carbon reinforced PEEK.
 - Available with positive material identification (PMI) certification on request.
 - ISO 9001, ISO 14001, IAFT 16949
 - ATEX certification available for APP S (all Super Duplex) and APP S 674 (API). Please see relevant data sheets.

3. Application examples

Danfoss APP pumps are built into a broad range of RO desalination plants around the world:

- Containerized solutions for hotels, resorts and residences on islands and in coastal regions
- Mobile systems for humanitarian and military organizations
- Onboard systems for ships and yachts
- Offshore platforms for the oil and gas industry
- Municipal and regional waterworks

4 Technical data

4.1 APP 53-92

Pump size		APP 53/1500	APP 65/1500	APP78 /1500	APP 86/1700	APP 92/1780
Code number		180B7806	180B7807	180B7808	180B7809	180B7810
Geometric displacement	cm ³ /rev.	617	778	888	888	888
	in ³ /rev.	37.7	47.3	54.2	54.2	54.2
Pressure						
Max. outlet ¹⁾ pressure (MAWP)	barg	80	80	80	70	70
	psig	1,160	1,160	1,160	1,015	1,015
Min. inlet operating pressure	barg	2	2	2	2.5	3.5
	psig	29	29	29	36	50
Max. inlet operating pressure	barg	5	5	5	5	5
	psig	73	73	73	73	73
Max. inlet pressure peak	barg	10	10	10	10	10
	psig	145	145	145	145	145
Min. outlet pressure	barg	30	30	30	30	30
	psig	435	435	435	435	435
Speed						
Min. speed continuous	rpm	700	700	700	700	700
Max. speed continuous	rpm	1,500	1,500	1,500	1,700	1,780
Flow						
Min. flow	m ³ /h	24	32	36	36	36
	gpm	106	141	158	158	158
700 rpm at max. pressure	m ³ /h	24	32	36	36	36
	gpm	106	141	158	158	158
1000 rpm at max. pressure	m ³ /h	35	45	52	52	52
	gpm	154	198	228	228	228
1200 rpm at max. pressure	m ³ /h	42	54	62	62	62
	gpm	187	238	275	275	275
1500 rpm at max. pressure	m ³ /h	53	68	78	78	78
	gpm	235	299	345	345	345
1700 rpm at max. pressure	m ³ /h				88	88
	gpm				387	387
1780 rpm at max. pressure	m ³ /h					92
	gpm					405
Efficiency						
1000 rpm ³⁾	%	88	88	89	89	89
1200 rpm ³⁾	%	89	89	90	89	89
1500 rpm ³⁾	%	88	89	89	88	88
1700 rpm ³⁾	%				88	88
1780 rpm ³⁾	%					87

Pump size		APP 53/1500	APP 65/1500	APP 78/1500	APP 86/1700	APP 92/1780
Code number		180B7806	180B7807	180B7808	180B7809	180B7810
Technical specifications						
Media ²⁾ temperature	°C	2-50	2-50	2-50	2-50	2-50
	°F	36-122	36-122	36-122	36-122	36-122
Ambient temperature	°C	0-50	0-50	0-50	0-50	0-50
	°F	32-122	32-122	32-122	32-122	32-122
Weight (dry)	kg	196	196	196	196	196
	lb	432	432	432	432	431
Weight (operation) ⁶⁾	kg	204	204	204	204	204
	lb	450	450	450	450	450
Sound pressure level	db(A)	84-95	84-95	84-93	84-96	84-96
Footprint with IE3 motor ⁴⁾	m ²	1.49	1.49	1.50	1.50	1.50
	Foot ²	16.0	17.0	16.1	16.1	16.1
Typical motor size						
Max. speed at max. pres- sure ⁵⁾	kW	132	160	160	200	250
	HP	200	250	250	300	300

¹⁾ Max. allowable working pressure at continuous operation. The pump is designed according to EN809, i.e. to withstand hydrostatic test pressure (HTP) of 1.3 x MAWP. For lower and higher pressure, please contact Danfoss.

²⁾ Dependent on the NaCl concentration.

³⁾ Typical efficiency at max. pressure after a system has been commissioned and run in.

⁴⁾ Maximum area covered with recommended IE3 motor configurations (excl. of space to service pump)

⁵⁾ IE3 and NEMA motors, 4-pole, current insulated ND non drive end bearing

⁶⁾ Operating with water

5. Performance curves

If the flow required and the rotation speed (rpm) of the pump is known, it is easy to select the pump, fitting the application best, by using the diagram below.

Furthermore, this diagram shows that the flow can be changed by changing the rotation speed of the pump. The flow/rpm ratio is constant, and the "required" flow can be obtained by changing the rotation speed to a corresponding value. Thus, the required rpm can be determined as:

$$\text{Required rpm} = \frac{\text{Required flow} \times \text{Rated rpm}}{\text{Rated flow}}$$

5.1 APP 53 flow at different rpm

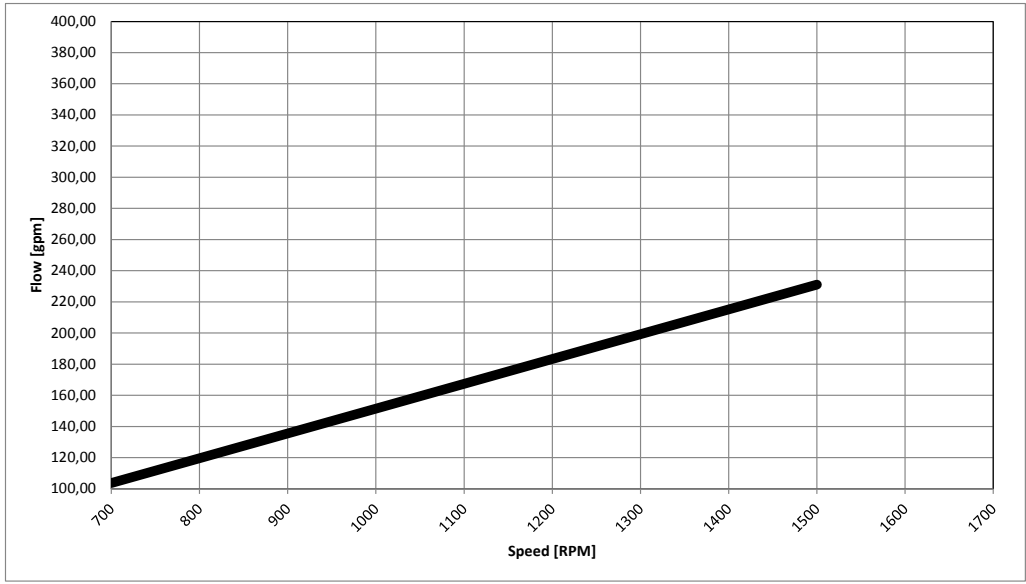
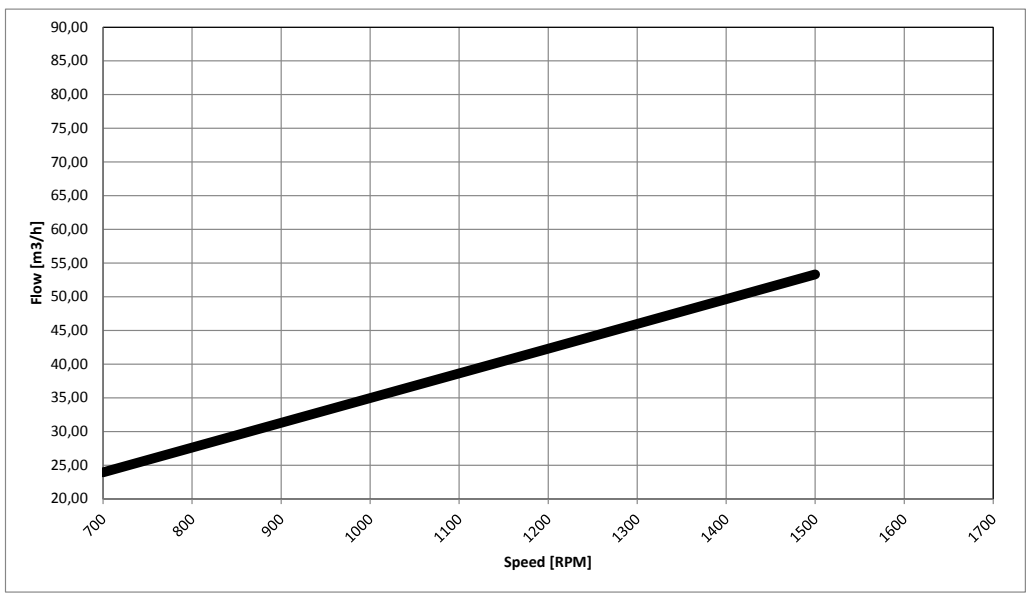

5.2 APP 65 flow at different rpm

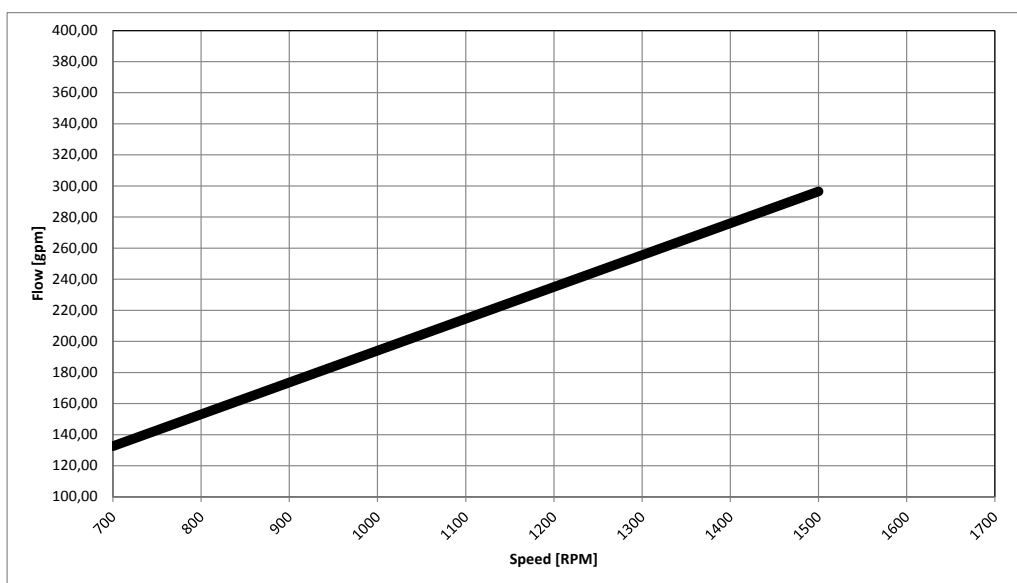
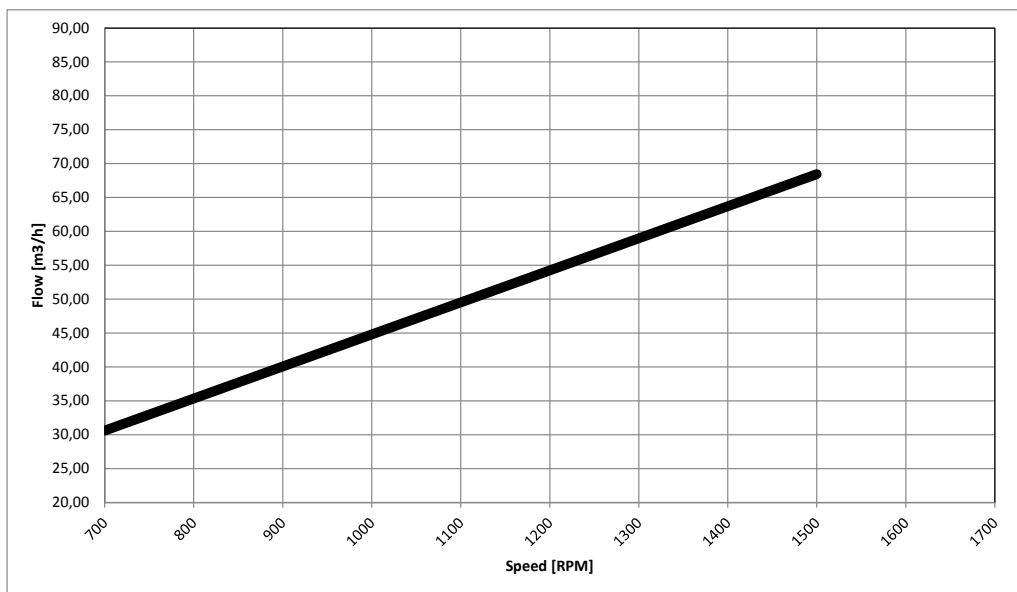

5.3 APP 78 flow at different rpm

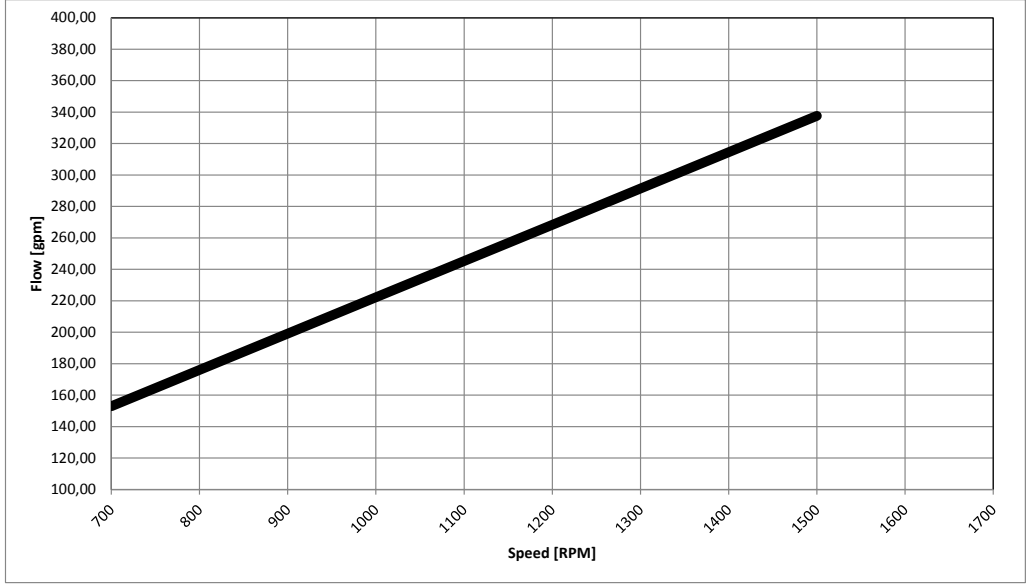
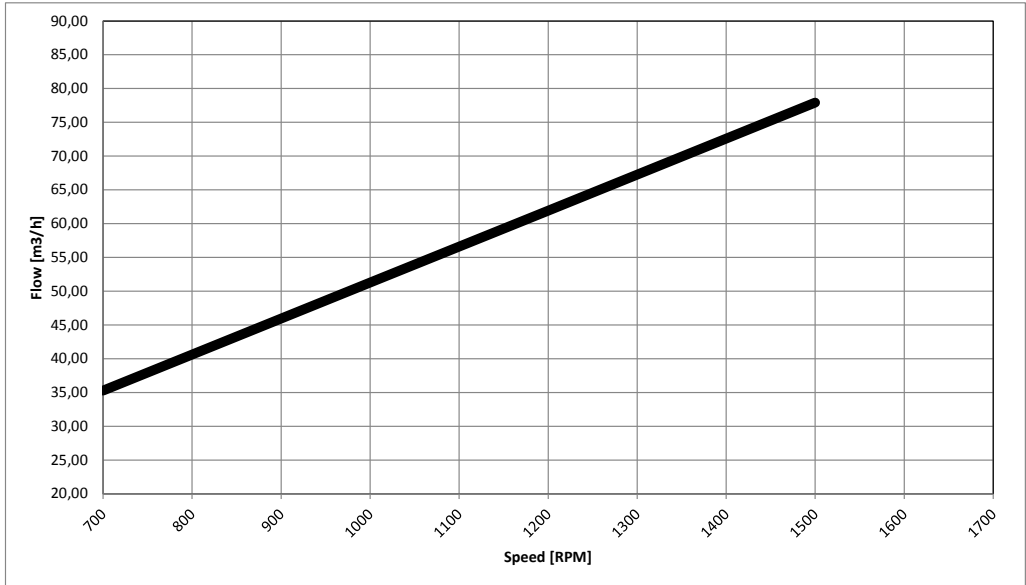

5.3 APP 86 flow at different rpm

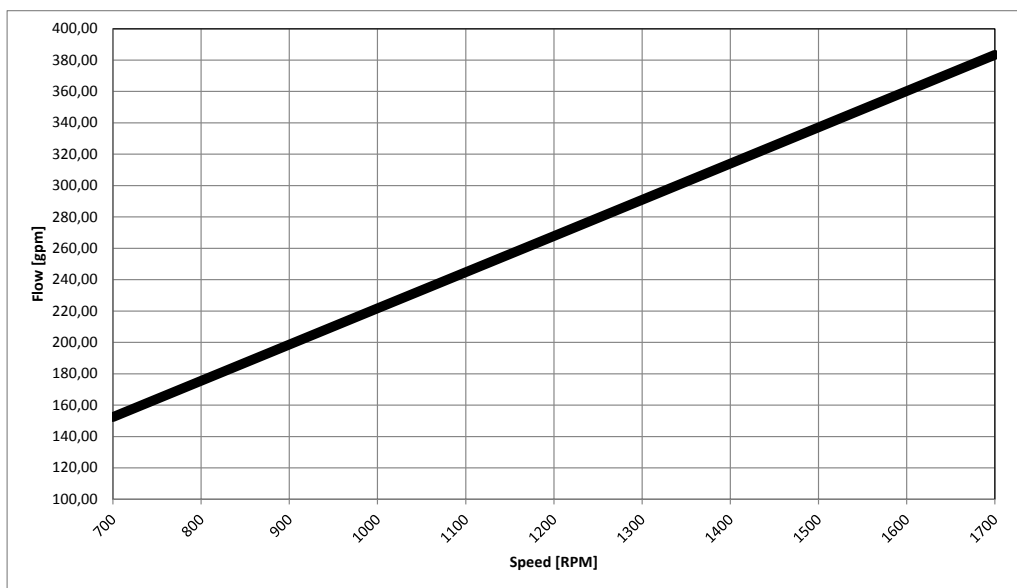
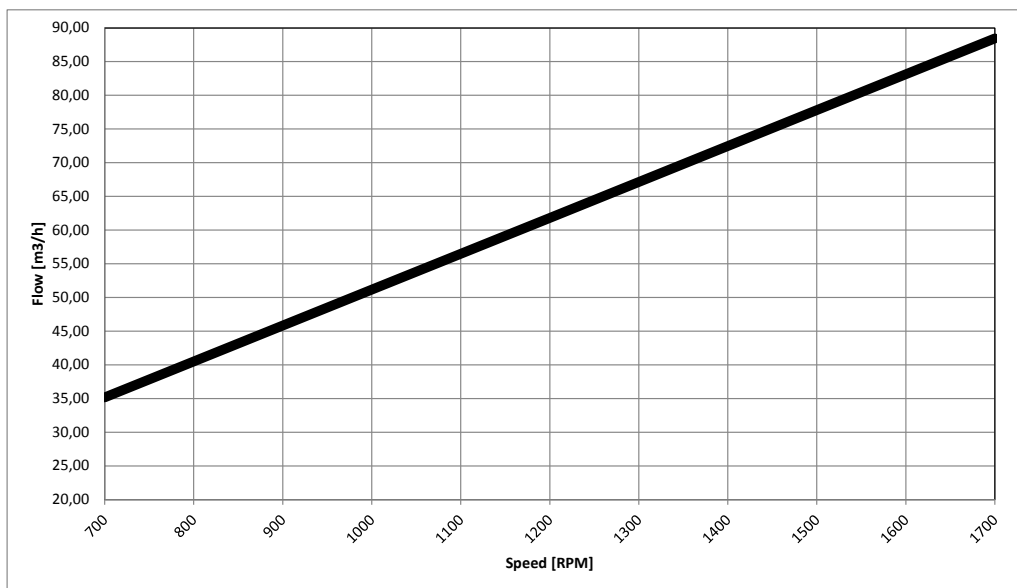

5.4 APP 92 flow at different rpm

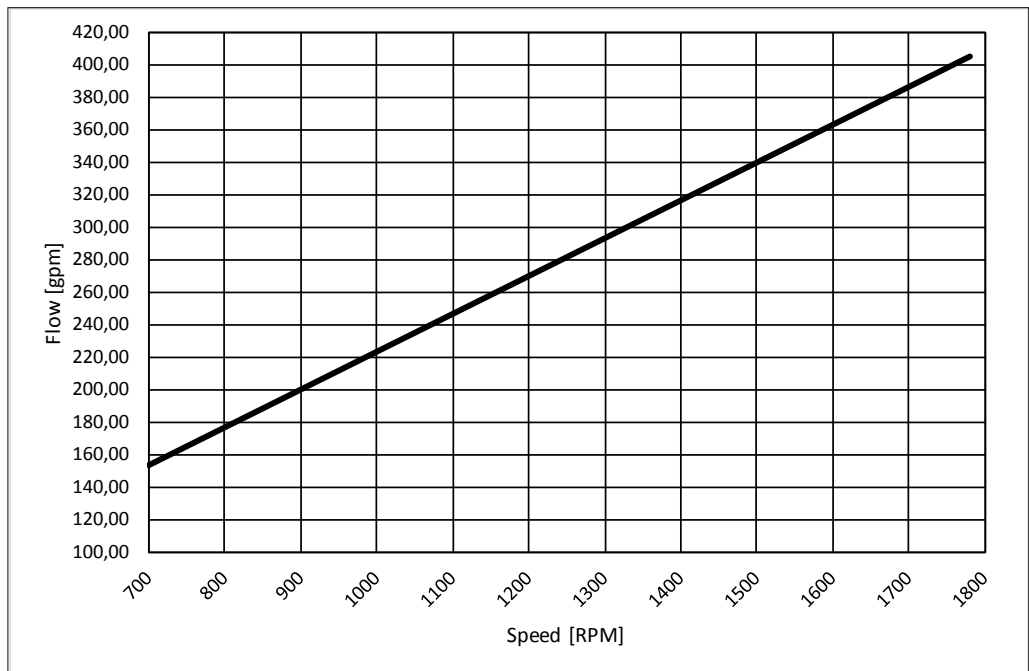
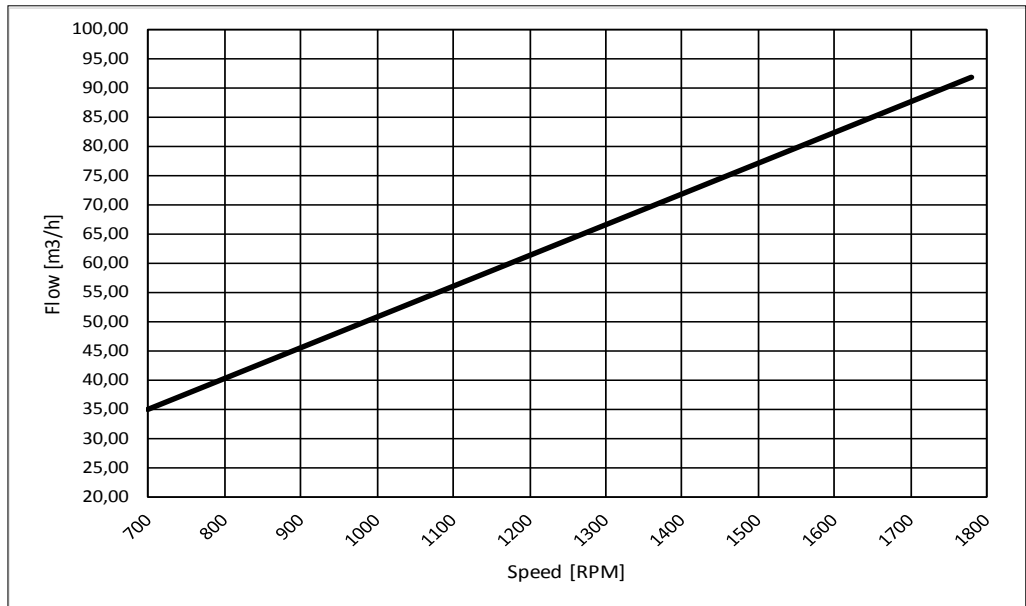

6. Flushing valve curves **6.1 APP 53-92 integrated flushing valve**

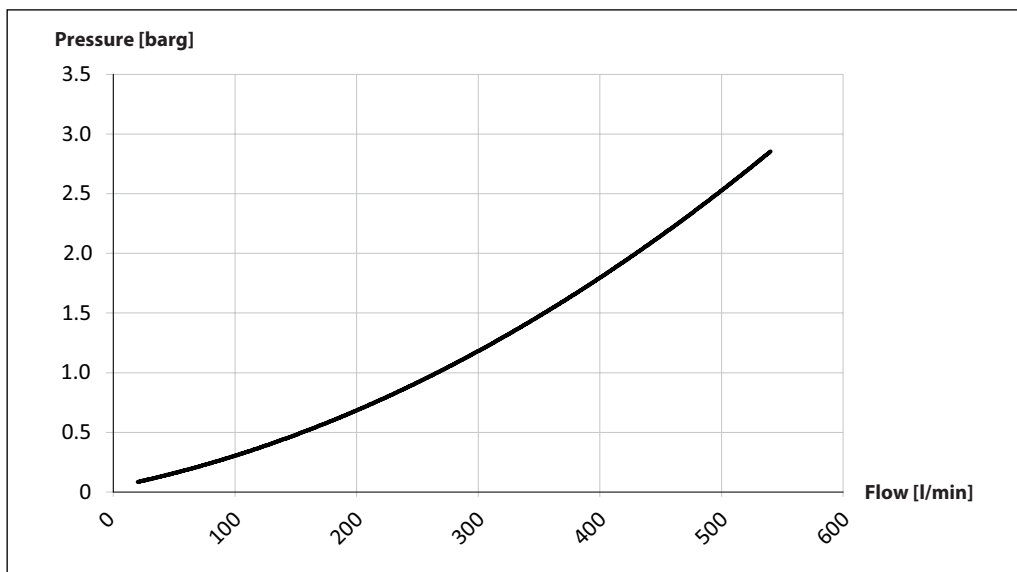

7. Motor requirements The power requirements can be determined using one of the following guiding equations:

$$\text{Required power} = \frac{\text{l/min} \times \text{barg}}{\text{Calc. factor}} \text{ [kW]} \text{ or } \frac{16.7 \times \text{m}^3/\text{h} \times \text{barg}}{\text{Calc. factor}} \text{ [kW]} \text{ or } \frac{0.35 \times \text{gpm} \times \text{psig}}{\text{Calc. factor}} \text{ [Hp]}$$

1 hp	=	0.75 kW
1 gpm	=	3.79 l/min
1 m ³ /h	=	4.40 gpm
1 kW	=	1.34 hp
1 l/min	=	0.26 gpm
1 gpm	=	0.23 m ³ /h

7.1 Calculation factor at 60 barg / 870 psig for APP 53-92

Name	rpm	Calculation factor
APP 53	1500	528
APP 65	1500	534
APP 78	1500	534
APP 86	1700	528
APP 92	1780	522

8. Temperature and corrosion

8.1 Operation

The chart below illustrates the corrosive resistance of different types of stainless steel related to NaCl concentration and temperature.

If the water pump is operated at high salinity always flush the water pump with fresh water at operation stop in order to minimize the risk of crevice corrosion.

All wetted parts of the APP pump are made of Duplex or Super Duplex.

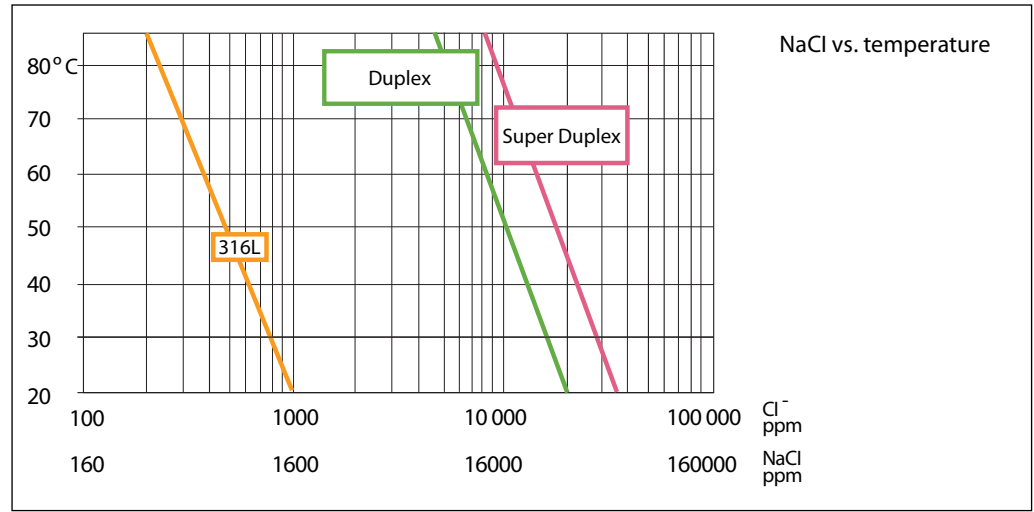

9. Installation

See example below on how to mount the pump and connect it to an electric motor or combustion engine (special coupling).

If alternative mounting is required, please contact your Danfoss sales representative for further information.

Note: Do not add any axial or radial loads to the pump shaft.

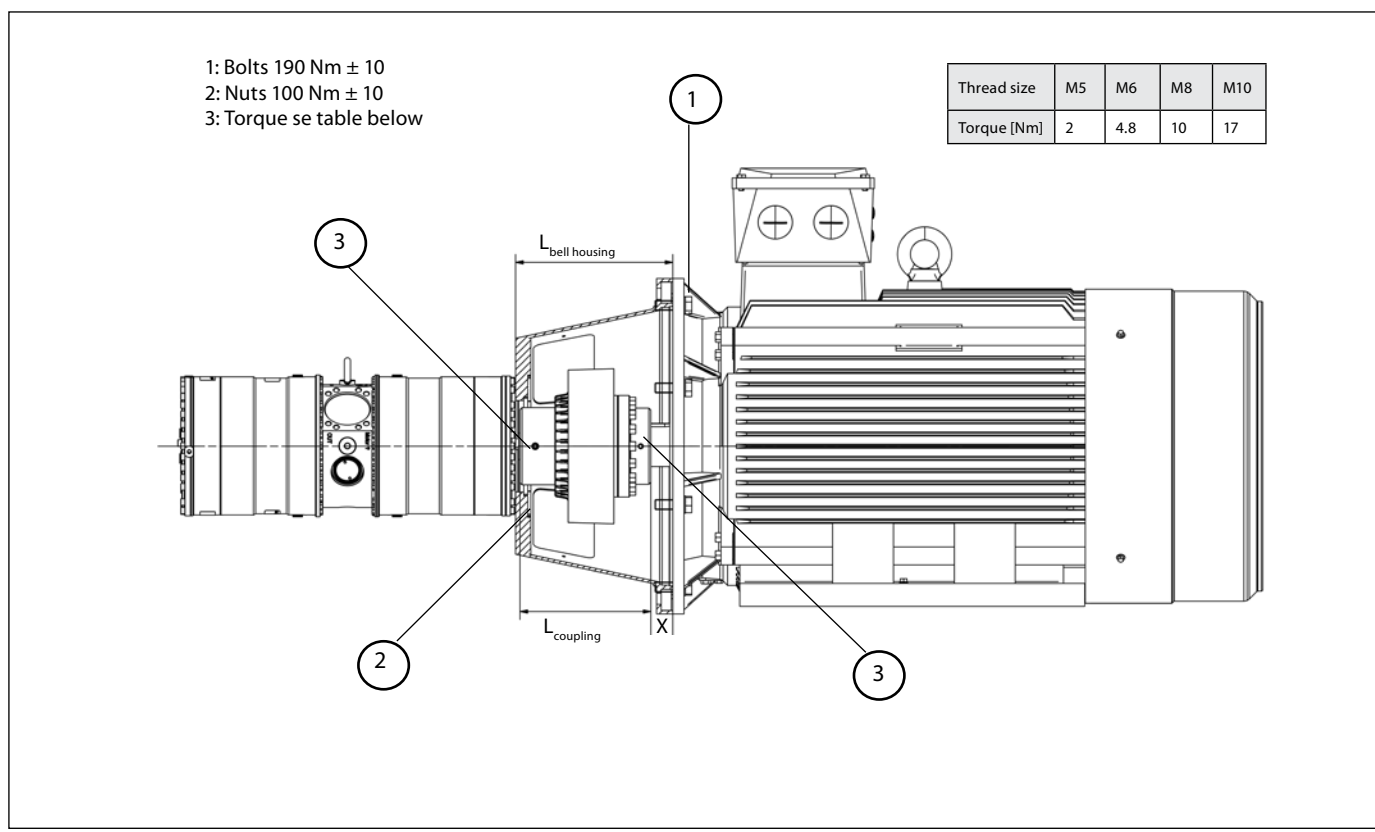

9.1 Filtration

Proper filtration is crucial for the performance, maintenance and warranty of your pump.

Protect your pump, and the application in which it is installed, by always ensuring that all filtration specifications are met, and by always changing filter cartridges according to schedule.

Since water has very low viscosity, Danfoss APP pumps have been designed with very narrow clearances in order to control internal leakage rates and improve component performance.

To minimize wear on the pump, it is therefore essential to filter inlet water properly.

The main filter must have a filtration efficiency of 99.98% at 10 µm. We strongly recommend that you always use precision depth filter cartridges rated 10µm abs. $\beta_{10} \geq 5000$.

Please note that we do not recommend bag filters or string-wound filter cartridges, which typically have only 50% filtration efficiency. This means that out of the 100,000 particles that enter such filters, 50,000 particles pass right through; compare this to precision depth filters that are 99.98% efficient, and only allow 20 of the same 100,000 particles to pass through.

For more information on the importance of proper filtration, including explanation of filtration principles, definitions and guidance on how to select the right filter for your pump, please consult our Filtration information and specifications (Danfoss document number 521B1009).

Noise

Since the pump unit is typically mounted on a frame or bell housing the overall noise level can only be determined for a complete system. To minimize vibrations and noise throughout the system, it is therefore very important to mount the pump unit correctly on a frame with anti-vibration-dampeners, and to use flexible hoses rather than metal pipes where possible.

The noise level is influenced by:

- **Pump speed:**
High rpm generates more fluid/structure borne pulsations/vibrations than low rpm, because of higher frequency.
- **Discharge pressure:**
High pressure generates more noise than low pressure.
- **Pump mounting:**
Rigid mounting generates more noise than flexible mounting, because of structure-borne vibrations. Be sure to use dampeners when mounting.
- **Connections to pump:**
Pipes connected directly to the pump make more noise than flexible hoses, because of structure-borne vibrations.

- **Variable frequency drives (VFD):**
Motors regulated by VFDs can produce more noise if the VFD does not have the right settings.

9.2 RO system with direct supply:

- Inlet line:**
- a) Dimension the inlet line to obtain minimum pressure loss (large flow, minimum pipe length, minimum number of bends/connections, and fittings with low or no pressure losses) .

- Inlet filter:**
- b) Install an inlet filter (1) in front of the APP pump (2). Please consult section 9.1, "Filtration" for guidance on how to select the right filter. Thoroughly clean pipes and flush system prior to start-up.

- Inlet pressure:**
- c) In order to eliminate the risk of cavitation and other pump damage, pump inlet pressure must always be maintained according to specifications described in item 4 about technical data.

- Low pressure relief valve:**
- d) Install a low pressure relief valve (9) in order to avoid system or pump damage in case the pump stops momentarily or is spinning backwards.

- Monitoring pressure switch:**
- e) Install a monitoring pressure switch (3) between the filter (1) and the pump inlet. Set the minimum inlet pressure according to specifications described in item 4 about technical data. If the inlet pressure is lower than the minimum pressure set, the monitoring pressure switch must prevent the pump from starting or from running.

- Hoses:**
- f) Always use flexible hoses (4) to minimize vibrations and noise. Please consult the Danfoss Hoses and hose fittings data sheet (521B0909) for guidance.

- Flushing valve:**
- g) For easy system filling and flushing, the APP pump has an integrated valve (6).

- Non-return valve:**
- h) A non-return valve (7) in outlet can be installed in order to avoid backspin of the pump. The volume of water in the membrane vessel works as an accumulator and will send flow backwards in case the pump stops momentarily.

- i) **High pressure safety or relief valve:**
 As the Danfoss APP pump begins to create pressure and flow immediately after start-up and regardless of any counter pressure, a safety or pressure relief valve (8) should be installed after the non-return valve to prevent system damage and to avoid high pressure peaks.

Note: If a non-return valve is mounted in the inlet line, a low-pressure relief valve is also required between the non-return valve and pump as protection against high-pressure peaks.

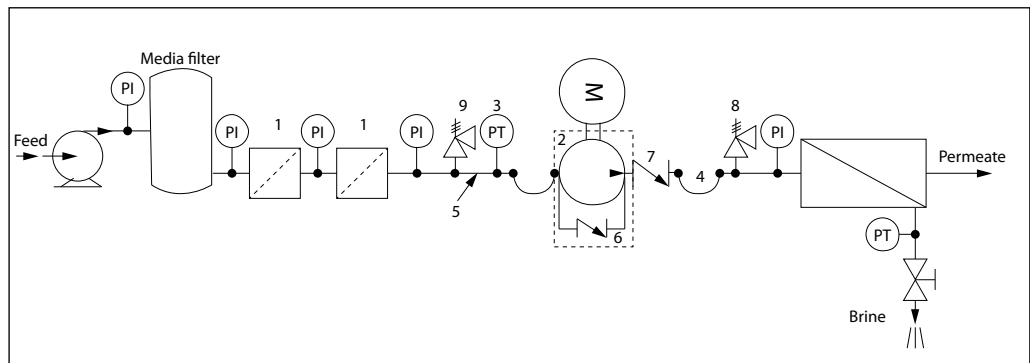

10. Dimensions and connections

10.1 APP 53

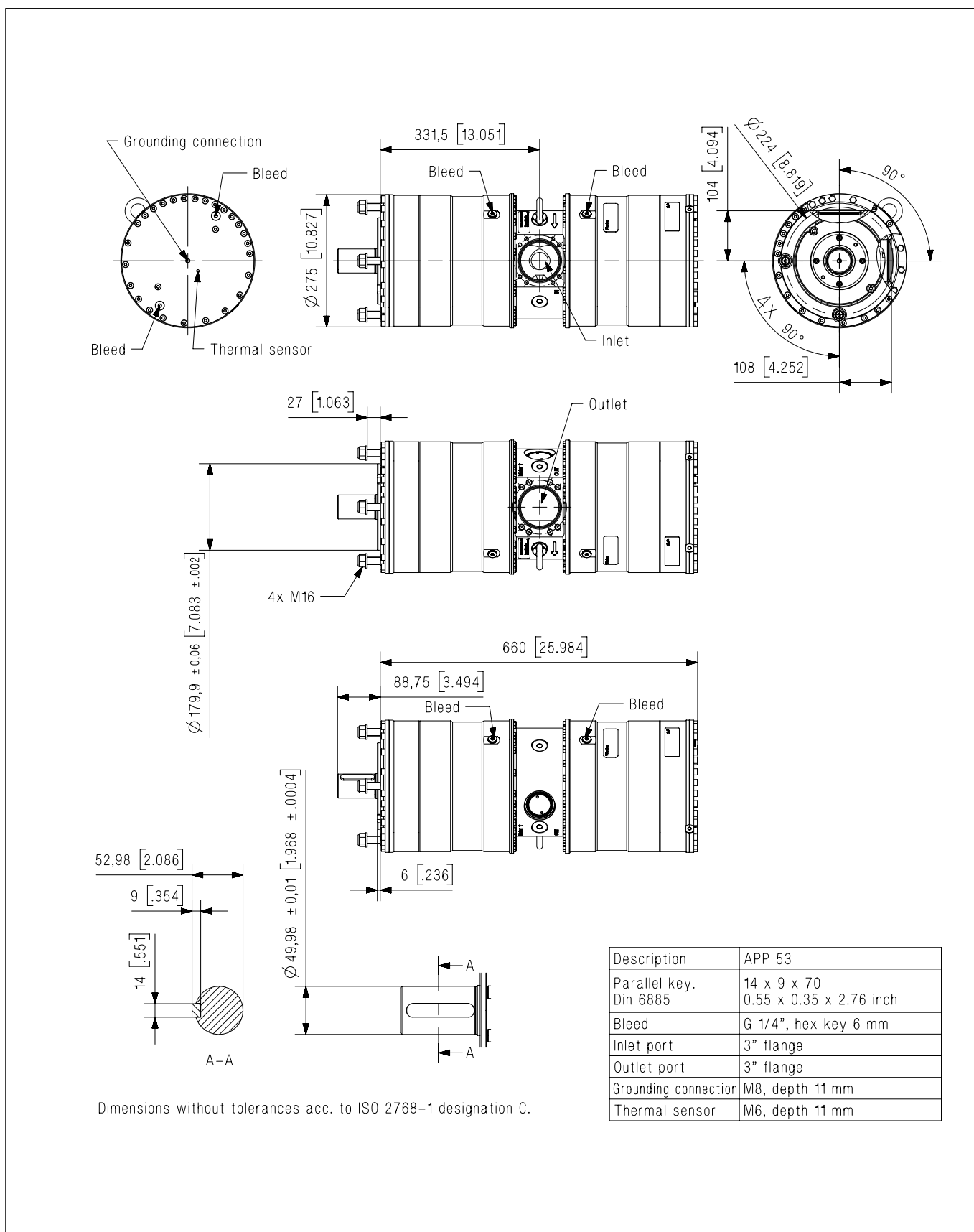

10.2 APP 65 - 92

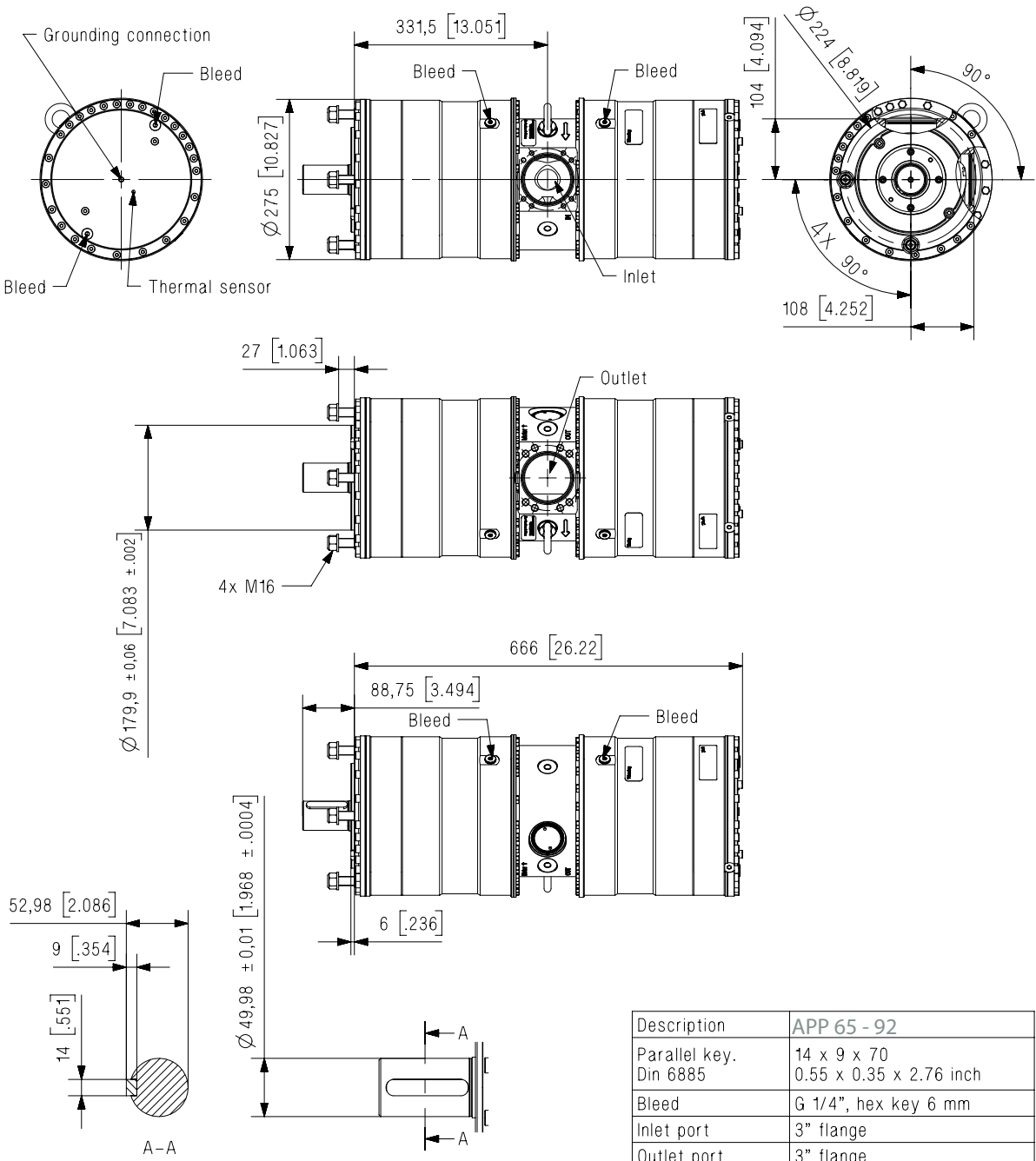

Dimensions without tolerances acc. to ISO 2768-1 designation C.

Description	APP 65 - 92
Parallel key.	14 x 9 x 70
Din 6885	0.55 x 0.35 x 2.76 inch
Bleed	G 1/4", hex key 6 mm
Inlet port	3" flange
Outlet port	3" flange
Grounding connection	M8, depth 11 mm
Thermal sensor	M6, depth 11 mm

The APP 53-92 connections (inlet and outlet) can be adjusted in intervals of 45 degrees. Please see typical installations with check valve VCM 92 mounted in the outlet port in the drawing below. Non-standard configurations are available on request. For adjustment on site, please see Installation, Operation and Maintenance Manual or contact Danfoss.

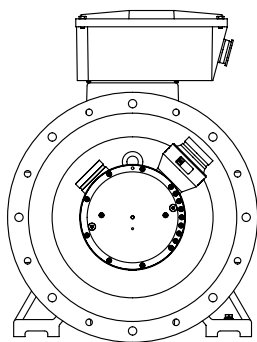

Standard configuration

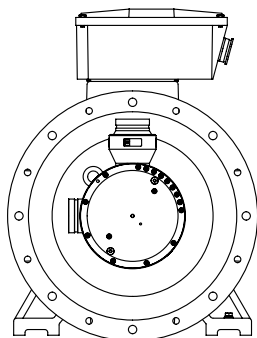
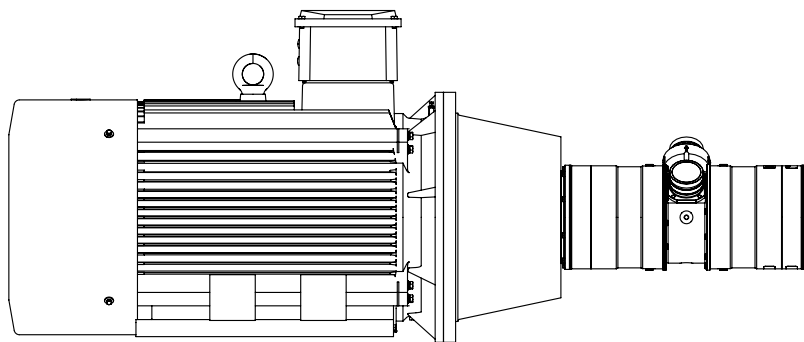

Non-standard configuration, turned 45 degrees left.

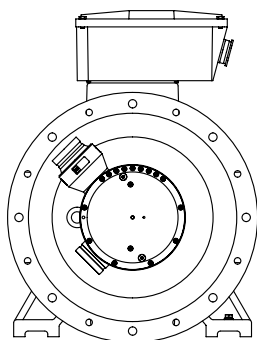
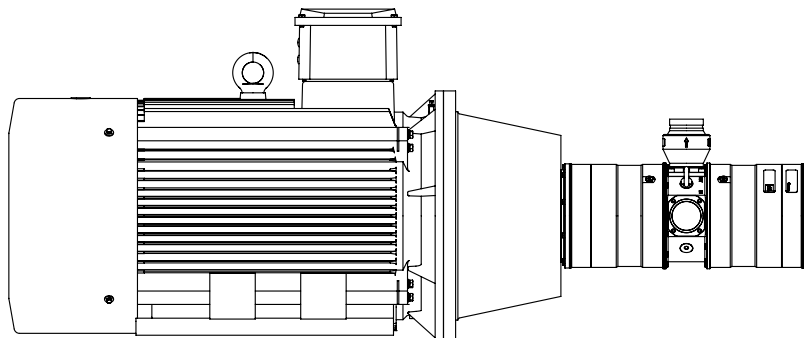

Non-standard configuration, turned 90 degrees left.

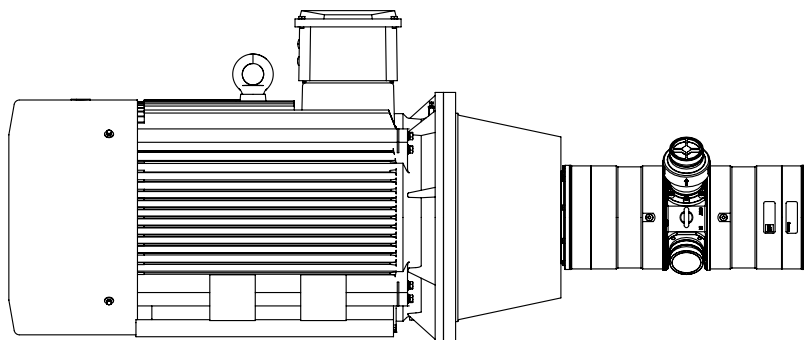

10.3 APP 53-92 with IE3 motor 110 kW

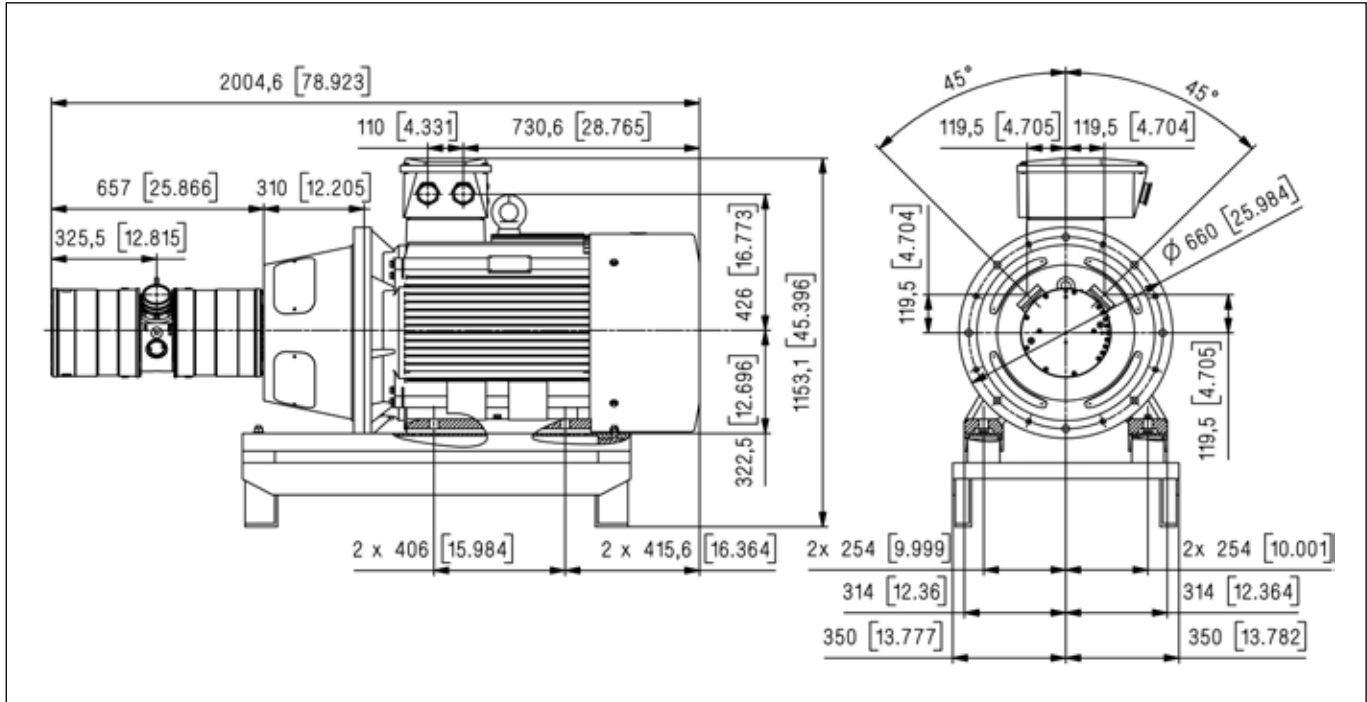

10.4 APP 53-92 with IE3 motor 132 kW

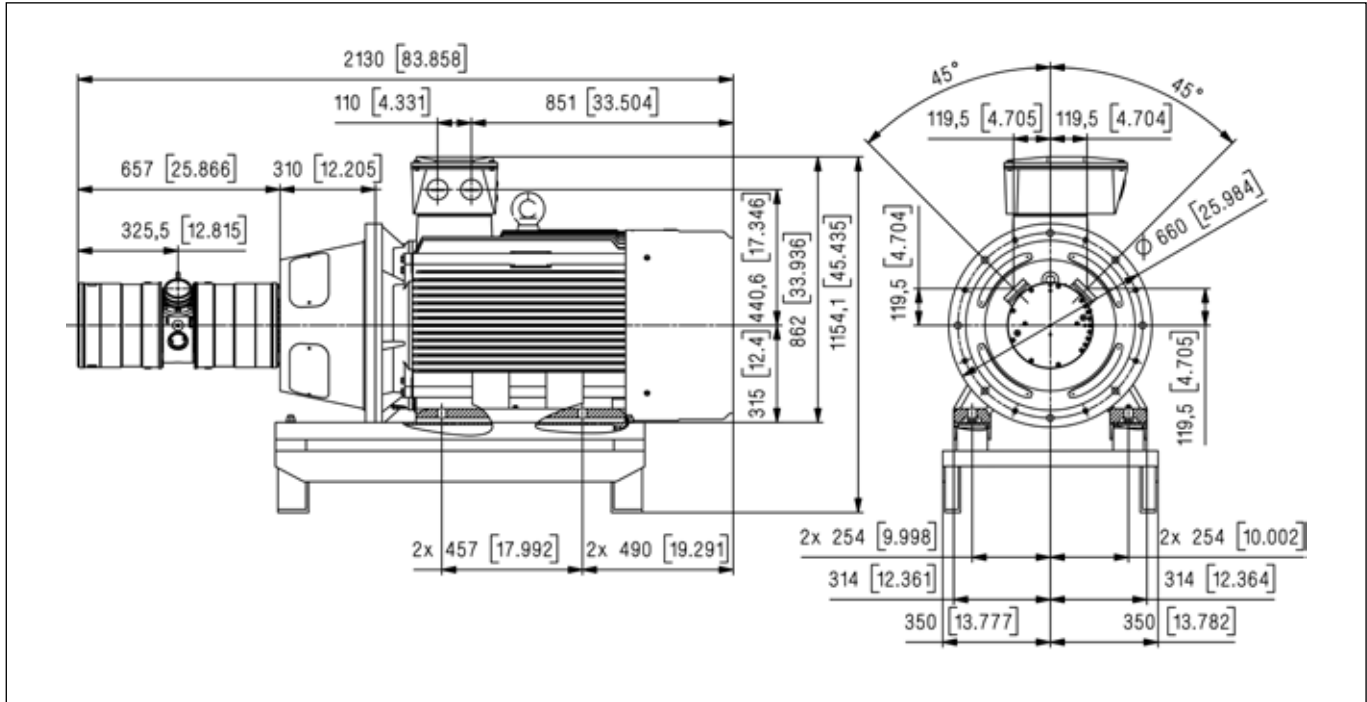

10.5 APP 53-92 with IE3 motor 160 kW

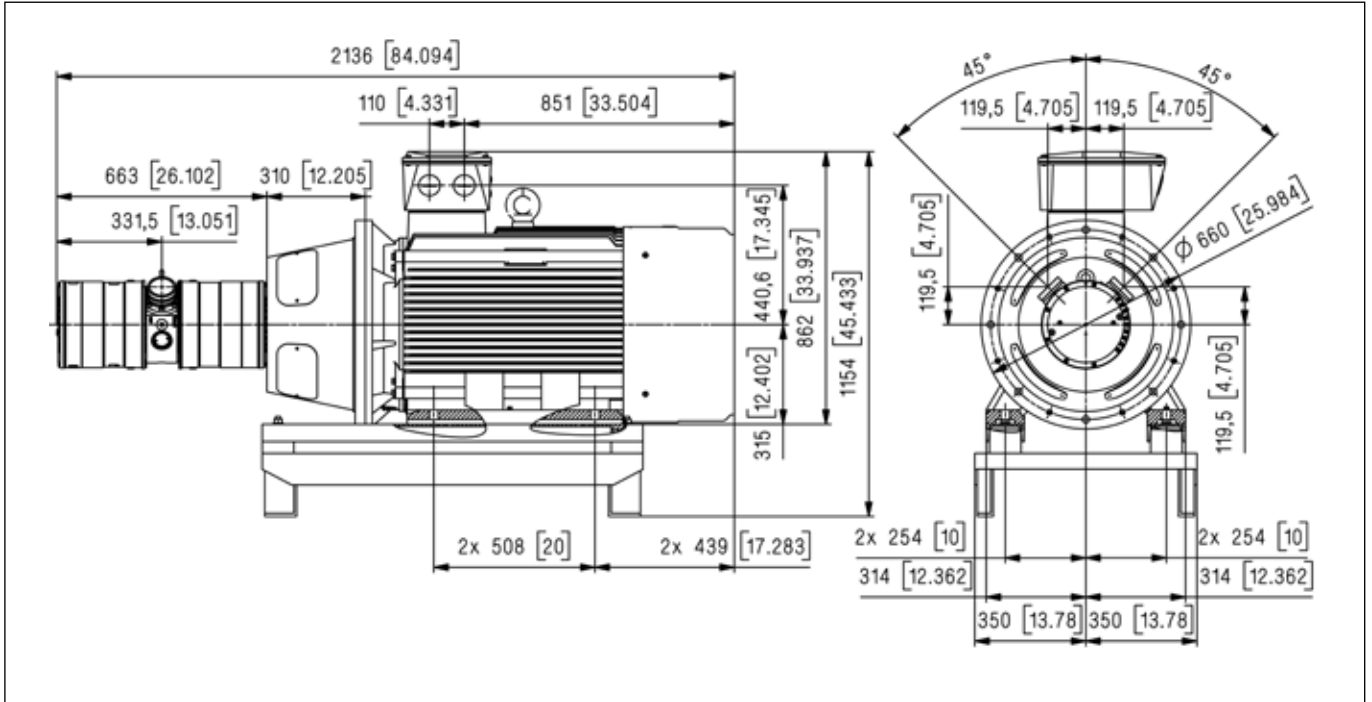

10.6 APP 53-92 with IE3 motor 200 kW

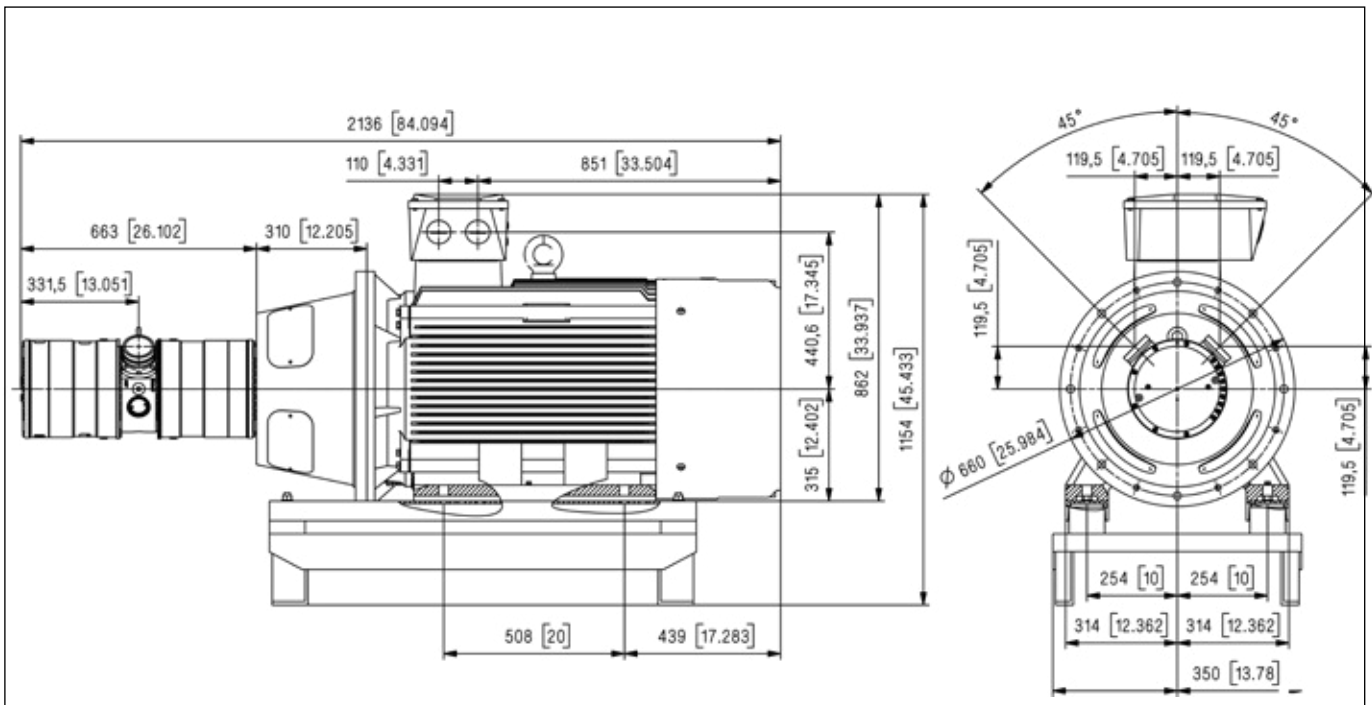

11. Pump connections

11.1 APP 53 - 92

Use only style 77DX coupling.

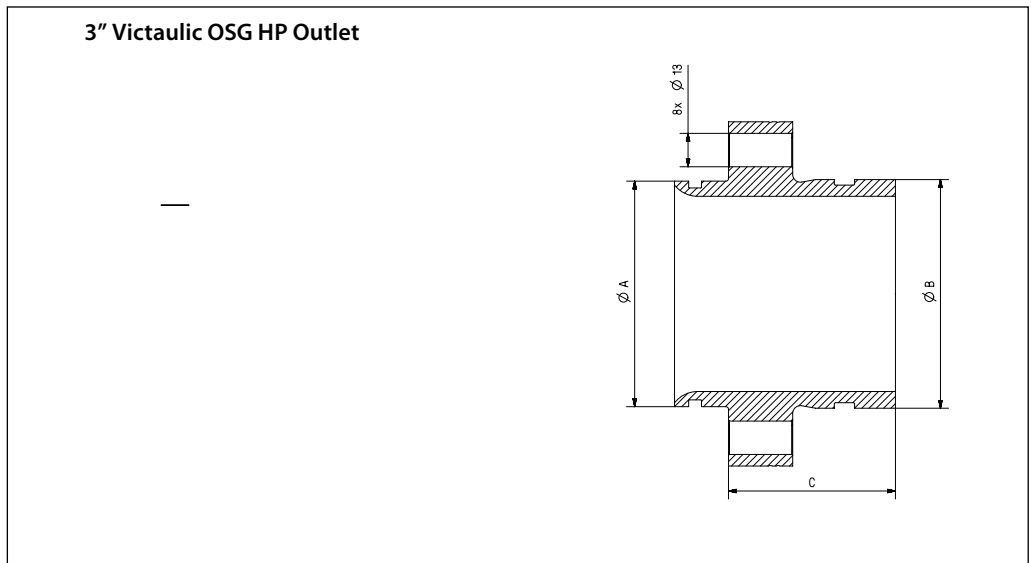
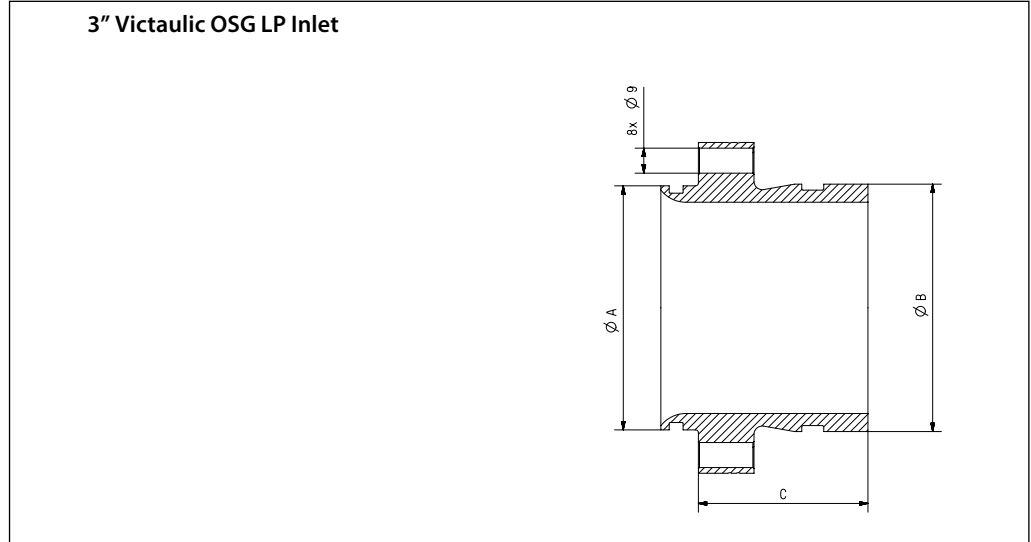

Connection	Diameter (A)	Victaulic ¹⁾ (B)	Length (C)	Material	Max. Pressure	Code number
3" Inlet connector	87.8 mm (3.46 inch)	3" Vic. OSG	61.0 mm (2.40")	Super Duplex	10 barg (145 psig)	180Z1991
3" outlet connector	87.8 mm (3.46 inch)	3" Vic. OSG	65.0 mm (2.56")	Super Duplex	80 barg (1160 psig)	180Z1992

¹⁾ The installation instruction for Style 77DX is located in the Victaulic document I-100 Field Installation Handbook (<http://static.victaulic.com>)

12. VCM 3" Victaulic

The non-return valve is designed for use in Seawater Reverse Osmosis (SWRO) membrane systems. In case the high-pressure pump stops momentarily, the volume of water in the membrane vessel may work as an accumulator and will send flow backwards.

When using multiple pumps in parallel, the non-return valve prevents the water from one pump to run into the parallel-coupled pumps at start-up. The valve is prepared for easy installation on the high-pressure outlet of APP 53-92.

Use only Style 77DX coupling

12.1 Technical data

Type	Connection ¹⁾	Diameter mm (inch)	Victaulic ³⁾ (outlet connection)	Length mm (inch)	Material ²⁾	Max. pressure barg (psig)	Code number
VCM 92	3" outlet check valve ¹⁾	87.7 (3.45)	3" Vic. OSG	180.5 (7.10)	Super Duplex	80 (1.160)	180H0058

¹⁾ The check valve is mounted directly in the outlet port with a flange with 8 screws M12 x 25.

²⁾ Wetted parts materials: Super Duplex, PEEK, PP, Hasteloy; FKM, NBR

³⁾ The installation instruction for Style 77DX is located in the Victaulic document I-100 Field Installation Handbook (<http://static.victaulic.com>)

VCM		VCM 92
Min. flow continuously	m ³ /h	20
	gpm	88
Max. flow continuously	m ³ /h	92
	gpm	405
Max pressure MAWP	barg	80
	psig	1160
Opening pressure	barg	0.05- 0.08
	psig	0.73-1.16
Pressure loss at max. flow	barg	< 0.45
	psig	< 6.5

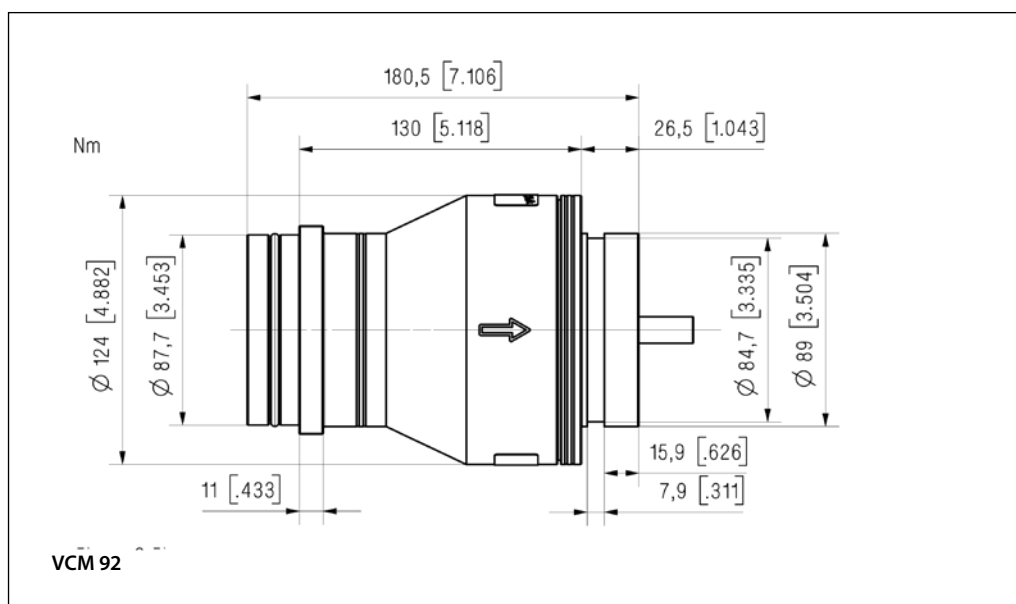

- 1. Valve housing (Super Duplex)
- 2. Valve guide and valve stop (Super Duplex, PEEK and PP)
- 3. Valve Cone (Super Duplex)
- 5. Spring (Hasteloy)
- 6. O-ring (NBR)
- 7. O-ring (FKM 75)
- 8. O-ring (NBR)

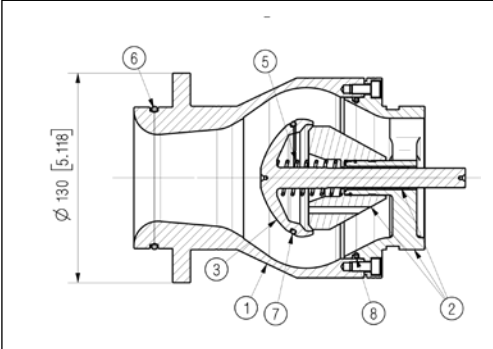

12.2 Flow versus pressure
Pressure drop curves for check valve VCM 92

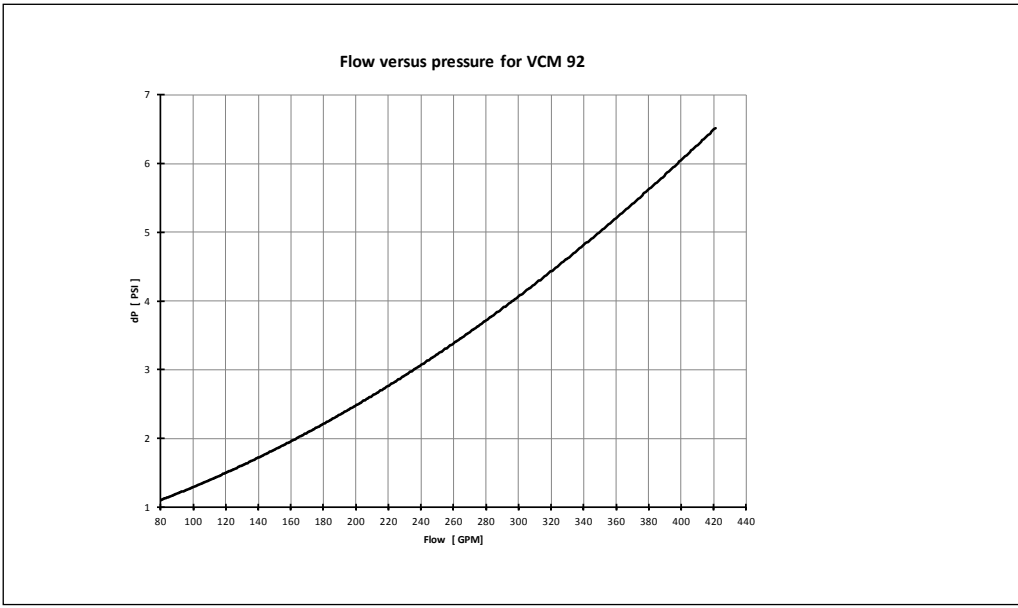
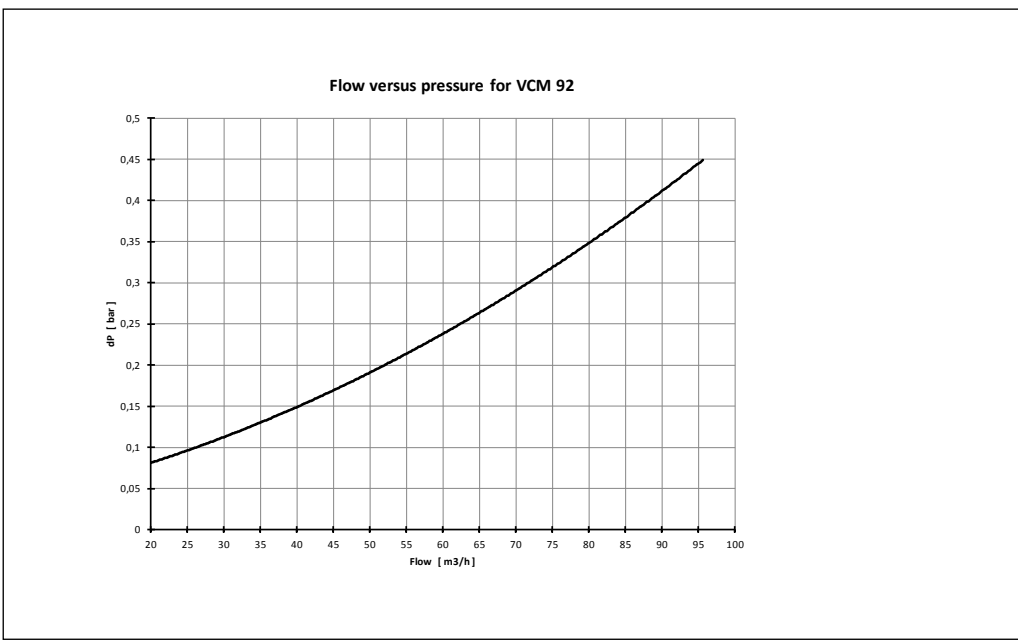

13. Accessories

Accessories	Type	Code number
3" Inlet hose kit - 2 m (79") 6 barg	3" Victaulic	180Z0144
3" Outlet hose - 1 m (39.4") 80 barg	3" Victaulic	180Z0611
Coupling APP 53 - APP 92 IEC 315	Bowex I-100 HEW Compact	180Z4066
Coupling APP 53 - APP 92 IEC 280	Bowex I-80 HEW Compact	180Z4081
Coupling kit APP 53 - APP 92 incl. bell housing IEC 315	Bowex ø660/310	180Z4083
Coupling kit APP 53 - APP 92 incl. bell housing IEC 280	Bowex ø550/265	180Z4082
Base frame incl. vibration dampeners	IEC 315	180Z0661

14. Service and warranty
Warranty

Danfoss APP pumps are designed for long operation, low maintenance and reduced lifecycle costs.

Provided that the pump has been running according to the Danfoss specifications, Danfoss guarantees 8,000 hours service-free operation, however, max. 18 months from date of production.

If Danfoss recommendations concerning system-design are not followed, it will strongly influence the life of the APP pumps. Other factors that affect pump performance and lifetime include:

- Insufficient filtration
- Insufficient bleeding and venting
- Running the pump at speed outside specifications.
- Supplying the pump with water at temperature higher than recommended.
- Running the pump at inlet pressure outside specifications.
- Running the pump at outlet pressure outside the specifications.
- Wrong direction of rotation.

Maintenance

After 8,000 hours of operation it is strongly recommended to inspect the pump and change any worn parts, e.g. pistons and shaft seal. This is done in order to prevent a potential breakdown of the pump. If the parts are not replaced, more frequent inspection is recommended according to our guidelines.

Pump shutdown:

The APP pumps are made of Duplex/Super Duplex materials with excellent corrosion properties. It is, however, always recommended to flush the pump with freshwater when the system is shut down.

Repair

In case of irregular function of the APP pump, please contact Danfoss High Pressure Pumps.

Danfoss A/S
High Pressure Pumps
DK-6430 Nordborg
Denmark