

Datasheet

# TP7000, TP7000-RF and TP7000M Programmable Room Thermostats

Features



The TP7000 combines the functions of a time clock and room thermostat into a stylish, simple to use controller that allows the user to programme different temperatures for different times to match lifestyle demands. The TP7000 offers true 7-day programming, allowing each day to be set differently if so required. In addition, the unit can be set to 5/2-day mode allowing one set of programmes to be used for weekdays with a different set being available for the weekends.

TP7000 is available in hard wired versions and in labour saving RF versions. Both hard wired and RF models offer up to six temperature changes each day and include the option of programming an "Off".

TP7000 offers several advanced features which can be selected by the installer at the time of installation, these include:

- Optimum start control :This feature uses internal temperature to calculate the time in advance of programmed time that the system must switch on in order to ensure that programmed temperature is achieved by the programmed time.
- Chrono-proportional control:This feature defines the boiler cycle rate and the on/off times of the boiler within the cycle. This adds to comfort and improves boiler efficiency, particularly with condensing type boilers.

RF models incorporate a digital FM radio transmitter which transmits a unique thermostat identity code which is learnt by the RX receiver during commissioning. Receivers, which are available in 1, 2 & 3 zone versions, can be mounted up to 30 metres from the thermostat and can be used to switch boilers, pumps or control valves.

The range includes battery and mains powered versions in both built-in and remote sensor types, please refer to the data table for details and ordering codes.

- 7-day or 5/2 day programming options
- Up to 6 time and temperature events per day
- Available in hard wired and RF versions
- Hard wired versions available for battery and mains operation
- Holiday programming mode and thermostat mode
- Many user overrides including programme extension

Installer Settings -  
DIL Switches

<b>All models</b>			
Sw <sup>1</sup>	5/2 day programming		7 day programming
Sw <sup>2</sup>	Optimum start controller enabled		Optimum start controller disabled
Sw <sup>3</sup>	Chrono-proportional control		On/Off control
<b>TP7000, A, B, AB, M, MA, RF &amp; A-RF models with 3/6 cycles per hour option</b>			
Sw <sup>4</sup>	Chrono-proportional, 6 cycles / hour		Chrono-proportional, 3 cycles / hour
<b>TP7000C, CA, CM, CMA, C-RF &amp; CA-RF models with 6/12 cycles per hour option</b>			
Sw <sup>4</sup>	Chrono-proportional, 12 cycles / hour		Chrono-proportional, 6 cycles / hour

Note: Sw<sup>4</sup> is only active if Sw<sup>3</sup> is set to chrono-proportional mode

# Datasheet

# TP7000 Series - Programmable Room Thermostats

## Installer Settings - Optimum Start Control

If DIL SW2 has been set to Optimum start control enabled, the Optimum start control setting must be made within the user programming mode. The table below shows the calculated time before the programmed time that the first event of the day will commence, dependant upon the difference in room temperature and the programmed temperature for the first event. Setting options are 0:00, (OSC disabled), 0:30, 1:00, 1:30 or 2:00).

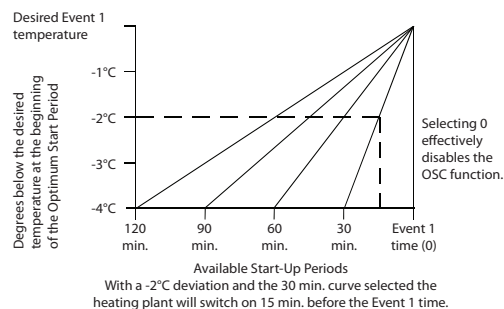

## Thermostat Specification

Thermostat Features		TP7000-RF		TP7000		TP7000M	
Order code	- Built-in Sensor	087N741000	087N741400	087N740000	087N740400	087N740800	087N741900
	- Remote Sensor (A models)	087N741100	087N741500	087N740100	087N740500	087N740900	087N742000
Control type - On/Off or Chrono-proportional, 3/6 cycles per hour		.		.		.	
Control type - On/Off or Chrono-proportional, 6/12 cycles per hour (C models)			.		.		.
RF - Wireless thermostat		.					
Hard wired thermostat				.			.
Digital clock type		24 hour (can be set to AM/PM mode by user)					
Selectable 7-day or 5/2-day operation		Yes					
Number of events per day		Up to 6					
Control temperature range		Off, 5-30°C (can be set to Fahrenheit by user)					
Total switching differential (On/Off mode)		<1.0°C					
Factory pre-set programme		Yes					
Programmable holiday mode		Yes, up to 99 days					
Installer selectable optimum start control		Yes - Off, 30, 60, 90 or 120 minutes early switch on at set-point minus 4K					
Thermostat mode and frost mode		Yes, set to 8.0°C, but adjustable between 5-30°C					
Power supply		2 x AA/MN1500/LR6 alkaline batteries			230V, 50 Hz		
Memory back-up		Capacitor during battery change for 1 minute			Rechargeable cell (see note 1)		
Switching action of output relay		N/A		SPDT			
Switch rating of relay contact, voltage and current		N/A		3 (1) A, 10-230 Vac			
Transmitter frequency (RF models only)		433.92 MHz		N/A			
Transmitter range (RF models only)		30 metres max.		N/A			
Dimensions (mm)		138 wide x 88 high x 28 deep					
Pollution situation		Degree 2					
Rated impulse voltage		N/A		2.5Kv			
Ball pressure test		75°C					
Note 1: Unit must be powered up for 6 days to charge cell before full back up is available							

## Receiver Specification (RF Models Only)

Receiver Features	RX1	RX2	RX3
Order codes	087N747600	087N747700	087N747800
Single channel receiver module, works in conjunction with one thermostat	.		
Two channel receiver module, works in conjunction with two thermostats		.	
Three channel receiver module, works in conjunction with three thermostats			.
Transmitter code self learning feature	.	.	.
Receiver frequencies	433.92 MHz		
Supply voltage	220/240 Vac, 50 Hz		
Output relay current rating	3 (1) A		
Output relay configuration (commons linked internally)	1 x SPDT	1 x SPDT 1 x SPST	1 x SPDT 2 x SPST
Memory retention	Memory retained electronically on power down		
Dimensions (mm)	138 wide x 88 high x 32 deep		

# Datasheet

# TP7000 Series - Programmable Room Thermostats

## ErP Class



ERP Class		
The products represented within this document are classified according to, and allow completion of, the Energy Related Product (ErP) Directive System Package fiche and the ErP system data label. ErP Labelling obligation is applicable from 26th September 2015.		
ErP Class	Product Function and ErP Description	Additional efficiency gain
IV	<b>TPI Room Thermostat, for use with on/off output heaters</b> An electronic room thermostat that controls both thermostat cycle rate and in-cycle on/off ratio of the heater proportional to room temperature. TPI control strategy reduces mean water temperature, improves room temperature control accuracy and enhances system efficiency.	2%

## Wiring Details

### TP7000 & TP7000A

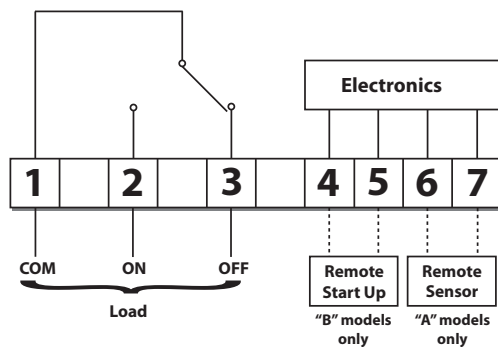

### RX1

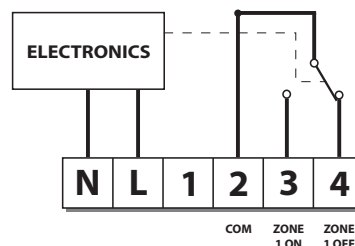

### TP7000M & TP7000MA

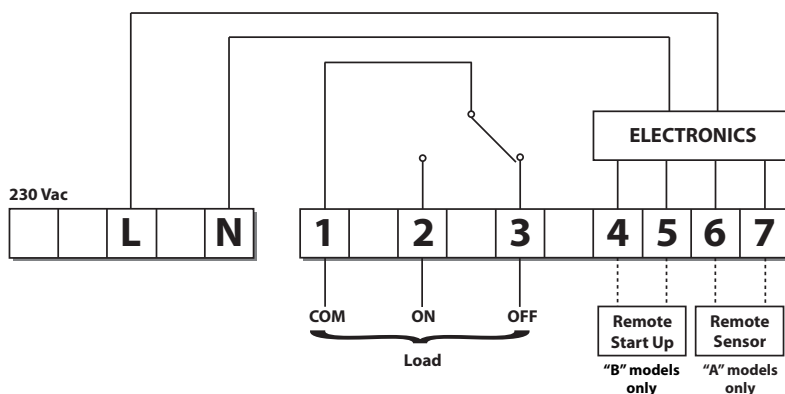

### RX2

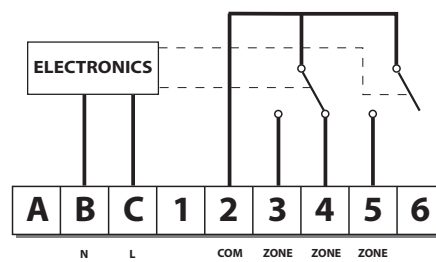

### TP7000-RF & TP7000A-RF

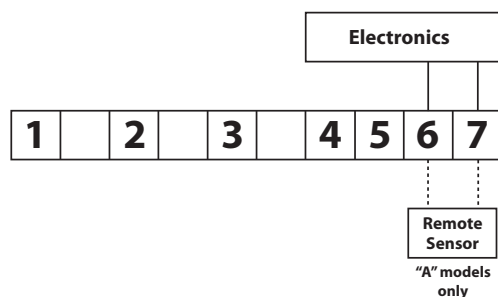

### RX3

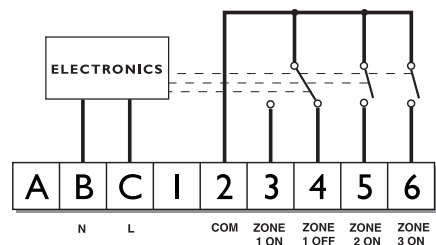

**Danfoss Randall Ltd.**

Ampthill Road  
Bedford MK42 9ER  
Tel: 0845 1217 400  
Fax: 0845 1217 515  
Email: danfosrandall@danfoss.com  
Website: www.danfoss-randall.co.uk

Danfoss can accept no responsibility for possible errors in catalogues, brochures, and other printed material. Danfoss reserves the right to alter its products without notice. This also applies to products already on order provided that such alterations can be made without subsequential changes being necessary in specifications already agreed.  
All trademarks in this material are property of the respective companies. Danfoss and the Danfoss logotype are trademarks of Danfoss A/S. All rights reserved.

---