

Data Sheet

ABN A5 Actuator for AB-QM, ON/OFF

Application



The ABN A5 on/off thermal actuator has been specifically designed for use with AB-QM valve sizes ½" to 1¼" for heating and cooling applications.

Features include:

- Actuator travel 5.0 mm
- Available as normally closed (NC) or normally open (NO)
- Power consumption 1/1.2 W
- Plug-in cable
- Simple snap-on installation
- IP54 in any installation position
- First-Open function
- Compact size, small dimensions
- All round function indicator
- Noiseless and maintenance-free
- Certified by TÜV

The actuator can be controlled with an on/off or PWM controller which is provided either by a room thermostat or by a central direct digital control (DDC) system.

Function

The actuator mechanism of the ABN A5 actuator uses a positive temperature coefficient (PTC) resistor heated wax element and a compression spring. The wax element is heated by applying the operating voltage and moves the integrated piston. The force generated by this movement is transferred to the piston, thus opening or closing the valve.

First open function (for NC versions only)

In its delivery condition, the ABN A5 is partially open to assist in the mounting of the actuator and filling of the system. Until the actuator is energized, the actuator is partially open. When power is wired to the actuator the first open function is unlocked and by applying the operating voltage for more than 6 minutes the ABN A5 will then be completely operable.

Version NC "normally closed" (valve closed)

In case of the normally closed version, when the actuator is powered the actuator steadily opens. When power is removed and after expiry of the hold time, the actuator closes in the same steady rate by the closing force of the compression spring.

The closing force of the actuator is matched to AB-QM ½" to 1¼" valves and keeps the valve closed when de-energized.

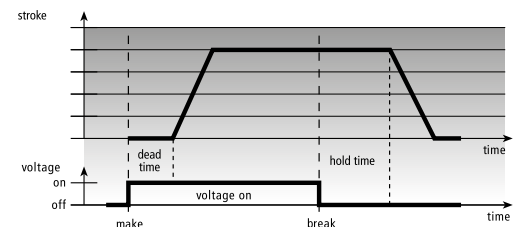

Fig. 1: Example of opening curve.

Version NC with end switch (082F1154)

The integrated micro switch is switched at a travel path of approx. 2 mm or 50% open. After the operating voltage is removed and after expiry of the hold time the valve is closed evenly by the closing force of the compression spring. The micro switch is closed after the actuator travels approx. 2 mm (50% closed) from full open.

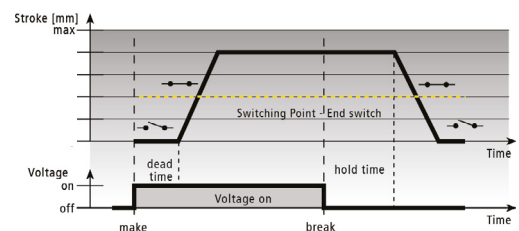

Fig. 2: Example of opening curve.

Version NO "normally open"

In case of the normally open version, the actuator will close when the operating voltage is applied to the actuator. After the operating voltage is removed and after expiry of the hold time, the actuator evenly opens by the compressive force of the internal actuator spring.

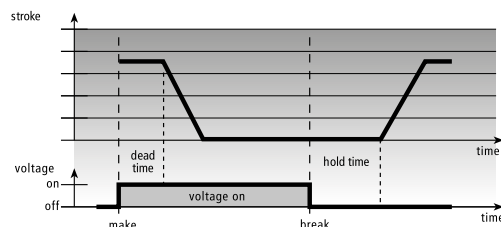

Fig. 3: Example of closing curve.

Function display

The function display, or position indicator of the ABN A5 is located on the top of the actuator. This position feedback allows identifying the operating condition (valve open or closed) at a glance.

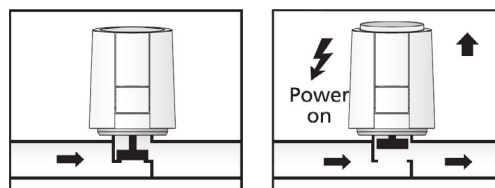

Fig. 4: Function display for NC versions extends proportionally with actuator opening from 0 mm to 5-6 mm.

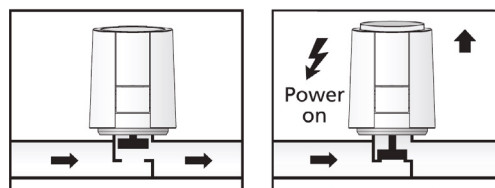

Fig. 5: Function display for NO versions extends only when valve is fully closed by approx. 0.5 mm.

Ordering

Type	Supply voltage	Normally Open/ Normally Closed	Cable	End Switch	Code no.
ABN A5, ON/OFF with VA 41 adapter, w/o cable (ordered separately, see below)	24 VAC/DC	NC	Plug-in, not included	No	082F1150
	24 VAC/DC	NO	Plug-in, not included	No	082F1151
	120 VAC	NC	Plug-in, not included	No	082F1156
	120 VAC	NO	Plug-in, not included	No	082F1157
	24 VAC/DC	NC	Pre-wired, 3 ft (1 m)	Yes	082F1154

(082F1154 is pre-wired to the actuator, no additional ordering of cable is required)

Cables

Cables are not included and should be ordered separately (not valid version with end switch). It is possible to select between different lengths and standard or halogen free material.

Cables	Material	Code no.
3ft (1m)	Standard (PVC)	082F1144
16ft (5m)	Standard (PVC)	082F1145
10 metres	Standard (PVC)	082F1146

Data

ABN A5 type	24 V
Version	NC / NO / NC w/ endswitch
Voltage	24 V AC/DC, +20%...-10%, 0-60 Hz
Max. inrush current	< 300 mA during max. 2 min.
Operating power	1 W (5 mm), 1.2 W (6.5 mm) ¹⁾
Control voltage	On/Off
Actuator travel	5 mm
Actuating force	100 N
Closing and opening time	~4 min.
Fluid temperature	32 to 212°F (0 to 100°C)
Storage temperature	-13 to 149°F (-25 to 65°C)
Ambient temperature	32 to 140°F (0 to 60°C)
Degree/class of protection	IP54 ²⁾ /III safety extra-low voltage
CE conformity according to	EN60730, UL60730
Housing/housing colour	Polyamid/White RAL9003
Connecting cable	2 x 0.75 mm ² PVC, or halogen free
Adapter (included)	VA 41
Overvoltage resistance EN60730-1	min. 2.5 kV
Weight	0.22lb (0.1 kg)

¹⁾ Measured with precision reference instrument LMG95.

²⁾ In all installation positions.

Connections

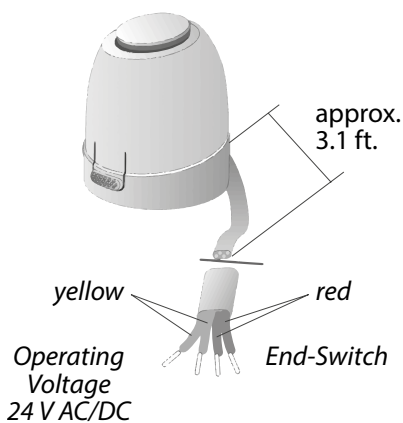

Cable connection of version with end switch 082F1154.

Installation

Installation with valve adapter

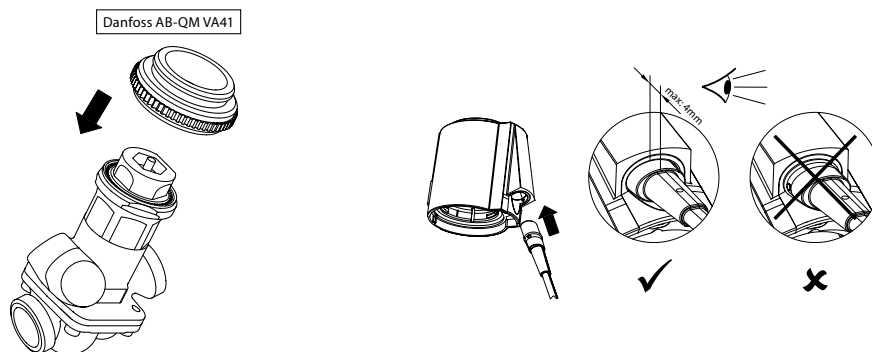

Screw the valve adapter manually onto the valve. Connect cable and actuator.

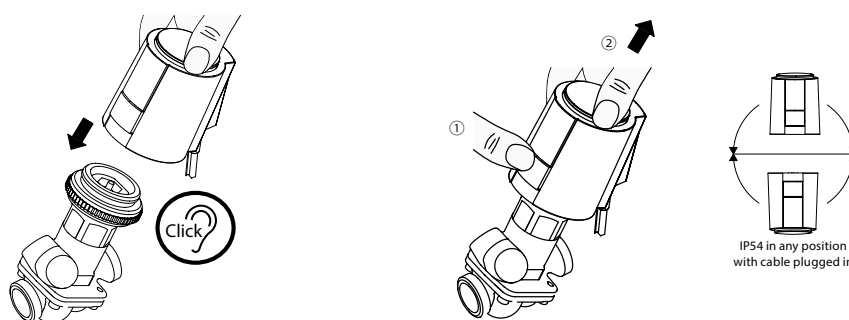

Place the actuator vertically on the valve adapter. The actuator snaps onto the valve adapter with a "click" when pressed down vertically by hand.

Dimensions

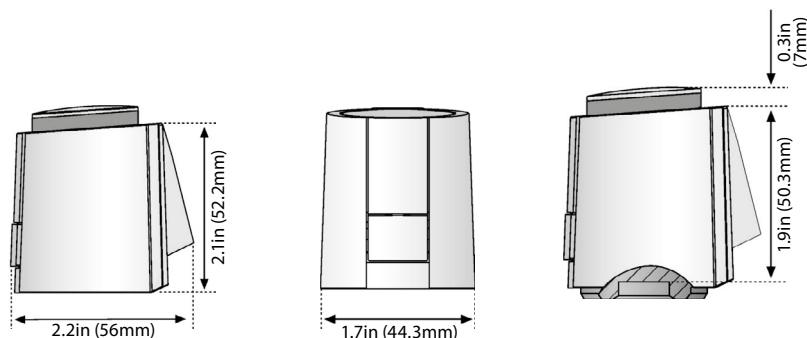

Danfoss can accept no responsibility for possible errors in printed materials and reserves the right to alter its products without notice. All trademarks in this material are property of the respective companies. Danfoss and Danfoss logotype are trademarks of Danfoss A/S. All rights reserved.



Danfoss
 Toronto, ON
 Tel.: 866-375-4822, Fax: 416-352-5981
 www.na.heating.danfoss.com

Danfoss
 Baltimore, MD
 Tel.: 443-512-0266, Fax: 443-512-0270
 www.na.heating.danfoss.com