

Data sheet

# Servo-operated 2-way proportional solenoid valves

## Type EV260B



EV260B is a proportional (modulating) servo-operated 2-way solenoid valve with connections from 1/4" to 3/4".

Through stepless regulation of the coil current, the armature can be placed in any position in the armature tube, thus setting the valve to any position between completely closed and completely open.

The valve is fully open when the coil current has reached its maximum value.

### Features and versions:

- For water, oil and similar neutral liquids
- Linear characteristic throughout the regulation range
- Closes on power failure (fail-safe function)
- Flow range from 0.5 – 12.7 m<sup>3</sup>/h
- Differential pressure from: 7.25 – 145 psi
- Media temperature from: 14 – 176 °F
- Ambient temperature: Up to 122 °F
- Coil enclosure: Up to IP67
- Viscosity: Up to 50 cSt
- Thread connections: From G/NPT 1/4 – 3/4
- DN 6 – 20
- Brass version NC
- Standard 4–20 mA or 0–10 V DC pilot signal
- Available with G and NPT thread.

**Brass valve body, NC  
G thread**



Conne- ction ISO 228/1	Seal material	Orifice size	K <sub>v</sub> - value [m <sup>3</sup> /h]	Differential pressure min. to max. [bar] / coil type			Media temperature min. to max. [°C]	Code number
				Terminal box	Signal converter 0 – 10V	Signal converter 4 – 20 mA		
				20 W DC	20 W DC	20 W DC		
G 1/4	PTFE	6	0.8	0.5 – 10	0.5 – 10	0.5 – 10	-10 – 80	<b>032U8052</b>
G 3/8	PTFE	6	0.8	0.5 – 10	0.5 – 10	0.5 – 10	-10 – 80	<b>032U8053</b>
G 3/8	PTFE	10	1.3	0.5 – 10	0.5 – 10	0.5 – 10	-10 – 80	<b>032U8054</b>
G 1/2	PTFE	10	1.3	0.5 – 10	0.5 – 10	0.5 – 10	-10 – 80	<b>032U8055</b>
G 1/2	PTFE	15	2.1	0.5 – 10	0.5 – 10	0.5 – 10	-10 – 80	<b>032U8056</b>
G 3/4	PTFE	20	5.0	0.5 – 10	0.5 – 10	0.5 – 10	-10 – 80	<b>032U8057</b>

**Brass valve body, NC  
NPT thread**



Conne- ction ISO 228/1	Seal material	Orifice size [inch]	C <sub>v</sub> - value [USgal/min]	Differential pressure min. to max. [psi] / coil type			Media temperature min. to max. [°F]	Code number
				Terminal box	Signal converter 0 – 10V	Signal converter 4 – 20 mA		
				20 W DC	20 W DC	20 W DC		
NPT 1/4	PTFE	1/4	0,9	7 – 145	7 – 145	7 – 145	14 – 176	<b>032U8062</b>
NPT 3/8	PTFE	1/4	0,9	7 – 145	7 – 145	7 – 145	14 – 176	<b>032U8063</b>
NPT 1/2	PTFE	3/8	1,5	7 – 145	7 – 145	7 – 145	14 – 176	<b>032U8065</b>
NPT 1/2	PTFE	9/16	2,4	7 – 145	7 – 145	7 – 145	14 – 176	<b>032U8066</b>
NPT 3/4	PTFE	3/4	5,8	7 – 145	7 – 145	7 – 145	14 – 176	<b>032U8067</b>

**Technical data, valve**

Installation	Vertical solenoid system is recommended.		
Pressure range	0.5 – 10 bar / 7 – 145 psi		
Max.test pressure	15 bar / 217 psi		
Rangeability	Better than 1:20 (5-100%)		
Ambient temperature	Up to 50 °C / 122 °F		
Viscosity	Max. 50 cSt		
Materials	Valve body	Brass	W.no. 2.0402
	Armature:	Stainless steel	W.no. 1.4105 / AISI 430FR
	Armature tube:	Stainless steel	W.no. 1.4306 / AISI 304L
	Spindle:	Stainless steel	W.no. 1.4105 / AISI 430FR
	Spring:	Stainless steel	W.no. 1.4568
	O-rings:	NBR / CR	–
	Valve plate:	FKM	–
	Diaphragm:	PTFE	–
Seat and guide ring:	PTFE	–	

Dimensions and weight

Type	Weight gross valve body without signal converter [kg]	Weight gross valve body with signal converter [kg]	L [mm]	L <sub>1</sub> with terminal box [mm]	L <sub>1</sub> with signal converter [mm]	L <sub>2</sub> [mm]	H <sub>1</sub> [mm]	H <sub>2</sub> [mm]	B [mm]
EV260B 6	1.02	1.22	62	112	128	30	13	71	68
EV260B 10	1.02	1.22	62	112	128	30	13	71	68
EV260B 15	1.17	1.37	81	112	128	30	15	74	68
EV260B 20	1.71	1.91	98	112	128	30	18	79	68

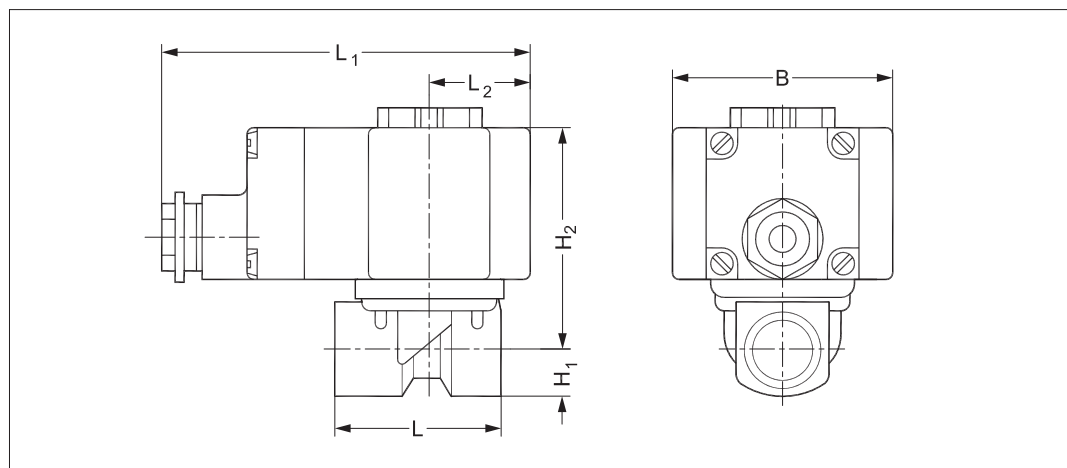

Dimensions

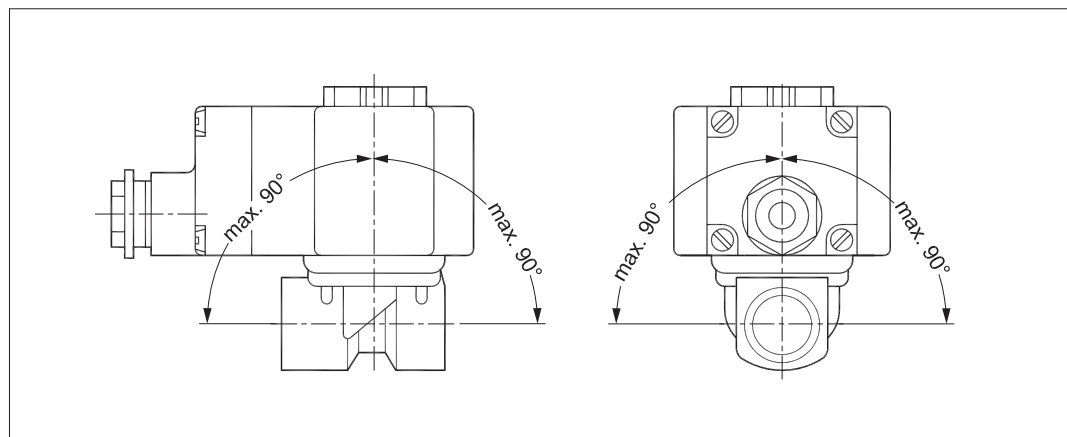

Mounting angle



Below coils can be used with EV260B

Coil	Power consumption	Supply voltage	Enclosure	Features	Code number
	20 W DC	24 V full wave rectified	IP67 only including seal kit 018Z0090	Terminal box	<b>018Z6987</b>
	20 W DC	21 – 30 V	IP65 only including seal kit 018Z0090	With signal converter Pilot signal: 0 – 10 V 2 meter cable	<b>018Z0290</b>
	20 W DC	21 – 30 V	IP65 only including seal kit 018Z0090	With signal converter Pilot signal: 4 – 20 mA 2 meter cable	<b>018Z0291</b>

Technical data, coil

Insulation of coil windings	400 k $\Omega$ for 0 - 10 V pilot signal. 250 $\Omega$ for 4 to 20 mA pilot signal
Coil resistance	23.5 $\Omega$ at an ambient temperature of 20 °C
Insulation of coil windings	Class H according to IEC 85
Duty rating	Continuous

Spare parts kit

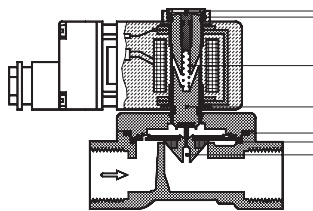

Type	Code number
EV260B 6	032U8039
EV260B 10	032U8040
EV260B 15	032U8041
EV260B 20	032U8042

EV260B spare parts kit comprises:

- Locking button and nut for the coil
- Complete armature with spring
- Diaphragm
- Adjustment screw including o-ring
- Two O-rings



Function

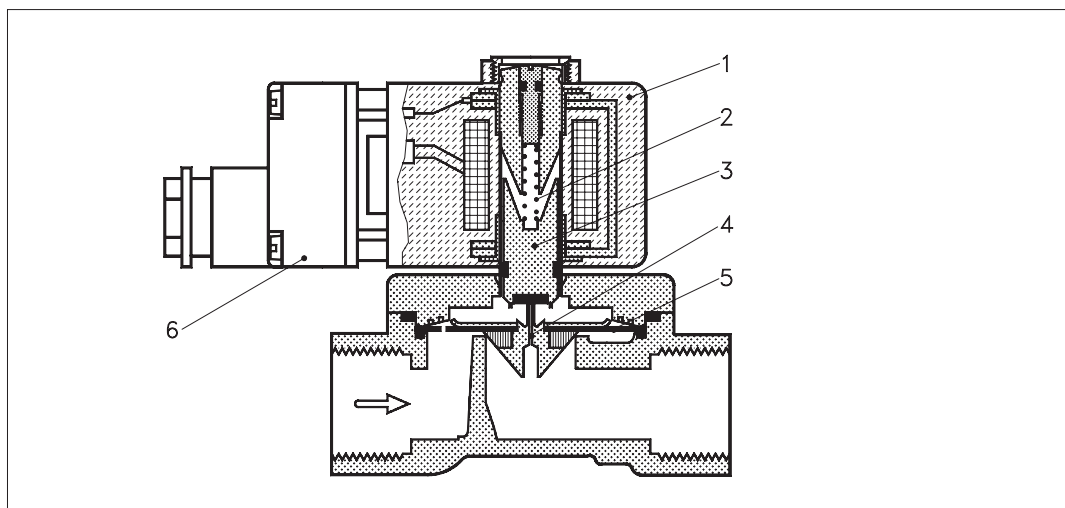

- 1. Coil
- 2. Closing spring
- 3. Armature
- 4. Pilot orifice
- 5. Diaphragm
- 6. Terminal box

Proportional regulation of the opening and closing of the EV260B valves is achieved through stepless regulation of the coil current and thus of the pulling force of the solenoid coil.

When the coil current is increased, the pulling force of the coil (1) will at a certain point exceed the counteracting spring force of the closing spring (2). The armature (3) moves up, opening the pilot orifice (4) in the diaphragm (5), which due to the servo effect follows the armature's movement.

The valve is fully open when the coil current has reached its maximum value.

Through stepless regulation of the coil current the armature can be placed in any position in the armature tube, and the valve thus set to any position between completely closed and completely open.

The effective coil current range for EV260B proportional valves without signal converter is approx. 300-600 mA.

The EV260B valves are also available with a signal converter built in the coil's terminal box (6). The signal converter's output terminals are connected to the solenoid coil.

The signal converter regulates the coil current so that it is proportional to the input signal (pilot signal).

- The pilot signal may be a
- 0 - 10 V DC voltage signal
  - or a
  - 4 - 20 mA current signal

Signal flow characteristics

*Coil type BK*

*Without signal converter*

The basic version consists of a valve with a coil for pulsating direct current. The supply voltage of 24 V DC can be established with full-wave rectified alternating current. The valve begins to open at a coil current of approx. 300 mA and is fully open at a coil current of approx. 600 mA. The ratio between coil current and flow between the two outer points is directly proportional.

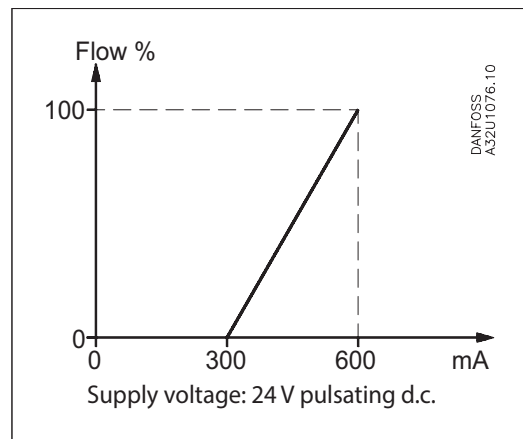

*Coil type BM*

*With signal converter and 0-10 V pilot signal*

The ratio between pilot signal and flow is directly proportional throughout the regulation range.

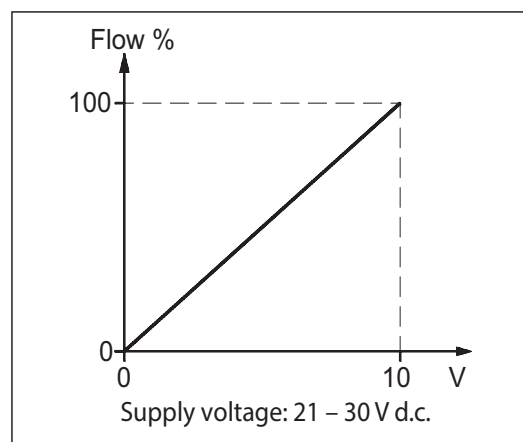

*Coil type BL*

*With signal converter and 4-20 mA pilot signal*

The ratio between pilot signal and flow is directly proportional throughout the regulation range.

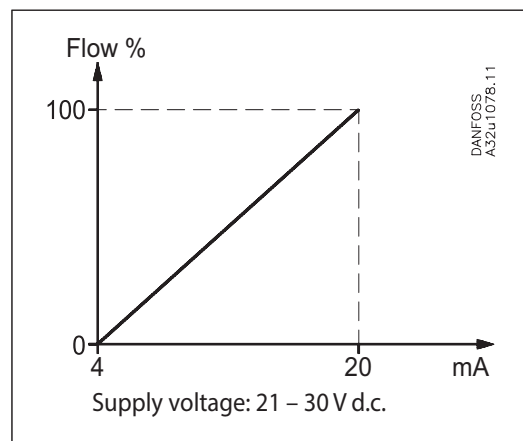

**Capacity diagram:**

Example:  
Capacity for EV260B 6 at differential  
pressure of 3 bgr.  
Approx. 1.4 m<sup>3</sup>/h

