

Data sheet

Modulating controlled actuator AME 11

Description



In addition to basic function such as manual control and position indication, the actuators are also equipped with force sensitive switch-off to ensure that actuators and valves are not exposed to overloading.

Main data:

- Nominal voltage: 24 Vac
- Force: 300 N
- Speed: 7 s/mm
- Max. medium temperature: 130 °C + adapter (150 °C)
- End-position signals

Note:

The use of AME actuators together with VS2 DN 15 is not recommendable. Linear characteristics as in VS2 DN 15 valves is not recommendable in DHW production.

The actuator is available for the modulating controllers with the control Y signal. It is used with VS2, VM2, VB2, VMV and AVQM valves.

Ordering

Actuators

Type	Supply voltage	Code No.
AME 11	24 V	082G3034

Accessories

Type	Code No.
High temperature adapter (150°C)	065Z7547

Technical data

Power supply	Vac	24; +10 to -15 %
Power consumption	VA	4.4
Frequency	Hz	50/60
Control input Y	Vdc	0-10 (2-10) Ri = 24 kΩ
	mA	0-20 (4-20) Ri = 500 Ω
Output signal X	Vdc	0-10 (2-10)
Closing force	N	300
Max. stroke	mm	7
Speed	s/mm	7
Max. medium temperature	°C	130 (150 with adapter)
Ambient temperature		0 ... 55
Storage and transport temperature		-40 ... 70
Ambient humidity	5-95 % r.h., non-condensing	
Protection Class	II	
Grade of enclosure	IP 54	
Weight	kg	0.6
 - marking in accordance with standards		Low Voltage Directive (LVD) 2014/35/EU: EN 60730-1, EN 60730-2-14 Electromagnetic Compatibility Directive (EMC) 2014/30/EU: EN 61000-6-2, EN 61000-6-3

Installation

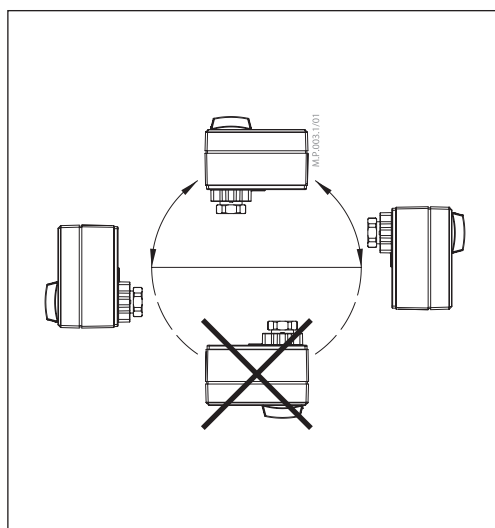

Mechanical

The actuator should be mounted with the valve stem in either horizontal position or pointing upwards.

The actuator is fixed to the valve body by means of a mounting ring, which requires no tools for mounting. The ring should be tightened by hand.

Electrical

Important: It is strongly recommended that the mechanical installation is completed before the electrical installation.

Note: Two cable entries are provided for M 16x1.5 cable glands. One entry is provided with a rubber grommet. Note that in order to maintain the enclosure's IP rating, appropriate cable glands must be used.

Disposal

The actuator must be dismantled and the elements sorted into various material groups before disposal.

Commissioning

Complete the mechanical and electrical installation and perform the necessary checks and tests:

- Isolate control medium. (e.g. self-adjusting in a steam application without suitable mechanical isolation could cause a hazard).
- Apply the power. Note that the actuator will now perform the self-adjusting function.
- Apply the appropriate control signal and check the valve stem direction is correct for the application.
- Ensure that the actuator drives the valve over its full stroke, by applying the appropriate control signal. This action will set the valve stroke length.

The unit is now fully commissioned.

Commissioning / testing feature

The actuator can be driven to the fully open or closed positions (depending on valve type) by connecting SN to terminals 1 or 3.

Manual Override

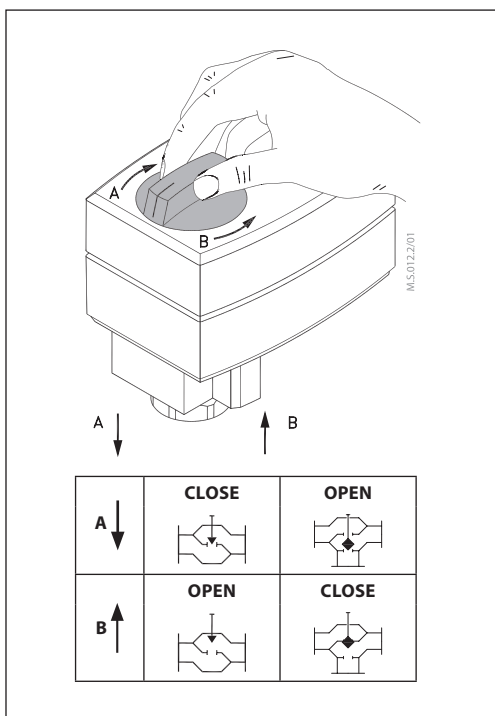

The manual override is achieved by turning the manual knob to the required position. Observe the direction of rotation symbol.

If manual override has been used then X and Y signal are not correct until the actuator reaches its end position. If this is not accepted reset the actuator.

- Disconnect power supply
- Adjust valve position using control knob
- Set valve to closed position
- Restore power supply

DIP switch setting

The diagram illustrates the DIP switch settings for the actuator. It shows a physical layout of 9 switches with their functions: 1 (U/I), 2 (0...10V), 3 (Inverse), 4 (Sequential), 5 (5(6)...10V), 6 (3 point/RL), 7 (LIN flow), 8 (Red. Kvs), and 9 (Reset). Below this, two wiring diagrams for the DIR terminal are shown, one for DIP 3 = OFF (DIR) and one for DIP 3 = ON (INV). To the right, two graphs show the relationship between input voltage (0V to 10V) and output current (0mA to 20mA) for the DIR terminal. The top graph shows a linear relationship for DIP 3 = OFF (DIR), and the bottom graph shows an inverse relationship for DIP 3 = ON (INV).

The actuator has a selection of DIP switches under the removable cover. The switch provides the following functions:

DIP1: U/I - Input signal type selector:

- If set to OFF position, input signal Y is set to voltage (Y).
If set to ON position, input signal Y is set to be current (mA).

DIP2: 0/2 - Input signal range selector:

- If set to OFF position, the input signal is in the range from 2 V to 10 V (voltage input) or from 4 mA to 20 mA (current input). If set to ON position, the input signal is in the range from 0 V to 10 V (voltage input) or from 0 mA to 20 mA (current input).

DIP3: D/I - Direct or inverse acting selector:

- If set to OFF position, the actuator is direct acting (actuator's stem extends by voltage increase). If actuator is set to ON position the actuator is inverse acting (actuator's stem retracts by voltage increase).

DIP4: —/Seq - Normal or sequential mode selector:

- Two actuators can be set to work parallel with one control signal. If the SEQUENTIAL is set than an actuator responds to split control signal (see 0(2) V ... 5(6) V / 5(6) V ... 10 V).

NOTE: This combination works in combination with DIP 5: 0(2) V ... 5(6) V / 5(6) V ... 10 V

DIP5: 0-5 V/5-10 V - Input signal range in sequential mode:

- This function is available if switch DIP 4: --- / Sequential is set. Actuator can be set to match the range of the control signal:
2 ... 6 V (DIP 2: 2 V ... 10)
0 ... 5 V (DIP 2: 0 V ... 10)
4 ... 12 mA (DIP 2: 2 V ... 10)
0 ... 10 mA (DIP 2: 0 ... 10)

OR

- 6 ... 10 V (DIP 2: 2 V ... 10)
- 5 ... 10 V (DIP 2: 0 V ... 10)
- 12 ... 20 mA (DIP 2: 2 V ... 10)
- 10 ... 20 mA (DIP 2: 0 ... 10)

DIP6: Prop./3-pnt - Modulating or 3-point mode selector:

Actuator can operate in modulating (DIP 6 to OFF) or in "simple" 3-point mode, if the 3-point function is selected (DIP 6 to ON).

Modulating mode; DIP 6 set to OFF (factory setting)

- After the actuator has been connected to power supply, the actuator will start the self-adjustment procedure. The indicator LED flashes until self-adjustment is finished.
- Actuator's stem will run to its totally extended or retracted position by bridging SN signal to terminals 1 or 3 and will remain in this position as long as potential is present.
It is not allowed to bridge SP to terminal 1 or 3 when DIP 6 is set to OFF .

3-point mode; DIP 6 set to On

Look carefully wiring diagrams as wiring is different for controllers with triacs output (ECL) in comparison to controllers with relay output.

- Connect SN (Neutral) and power supply (24Vac) via controller to terminals 1 or 3.
- Return signal X (depends on DIP 2, 3, 4 & 5) is possible if connected power supply to SP and SN.

SW7: LOG/LIN - Not in use.

SW8: 100 % K_{vs}/Reduced K_{vs} - Not in use.

SW9: Reset:

- Changing this switch position will cause the actuator to go through a self-adjustment procedure.

Wiring



24 Vac only.

DIP 6 = OFF **Wiring for modulating mode**

SN	0 V	Neutral
SP	24 Vac	Power supply
Y	0(2)-10 Vac 0(4)-20 mA	Input
1	SN	Input
3		
X	0(2)-10 Vdc	Output

Actuator needs to perform Self-adjusting prior changing DIP 6 to ON.
Output signal depends on DIP 2, 3&5 setting.

* Only for actuators with safety function

DIP 6 = ON **Wiring for 3-point floating mode / Controller with relay output**

SN	0 V	Neutral
SP	24 Vac	Power supply
1	SP	Input
3		
X	0(2)-10 Vdc	Output

DIP 6 = ON **Wiring for 3-point floating mode / Controller with triacs output**

SN	0 V	Neutral
SP	24 Vac	Power supply
1	SP	Input
3		
X	0(2)-10 Vdc	Output

*R1, *R2=2.6 kΩ (0.5W)

Automatic self-adjustment feature

When power is first applied, the actuator will automatically adjust to the length of the valve stroke. Subsequently, the self-adjustment feature can be re-initialised by changing position of SW9.

Wiring length	Recommended square of the wiring
0-50 m	0.75 mm ²
> 50 m	1.5 mm ²

Diagnostic LED

The red diagnostic LED is located on the pcb under the cover. It provides indication of three operational states:

- Actuator Healthy (Permanently ON),
- Self-adjusting (Flashes once per second),
- Error (Flashes 3 times per second - seek technical assistance).

Dimensions

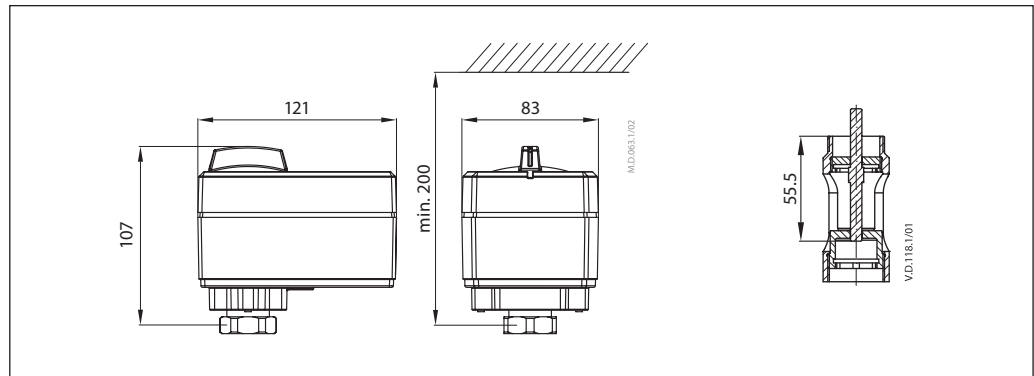

Actuator - valve combinations

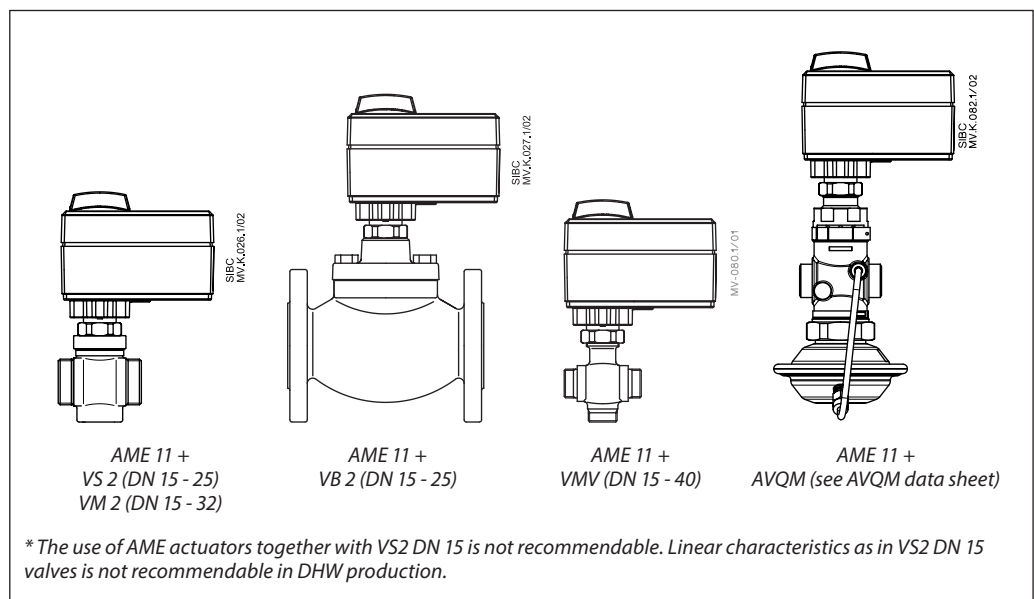



Danfoss A/S

Heating Segment • heating.danfoss.com • +45 7488 2222 • E-Mail: heating@danfoss.com

Danfoss can accept no responsibility for possible errors in catalogues, brochures and other printed material. Danfoss reserves the right to alter its products without notice. This also applies to products already on order provided that such alterations can be made without subsequential changes being necessary in specifications already agreed. All trademarks in this material are property of the respective companies. Danfoss and all Danfoss logotypes are trademarks of Danfoss A/S. All rights reserved.
