

## Data sheet

# Pressure independent balancing and control valve AB-QM DN 10-250

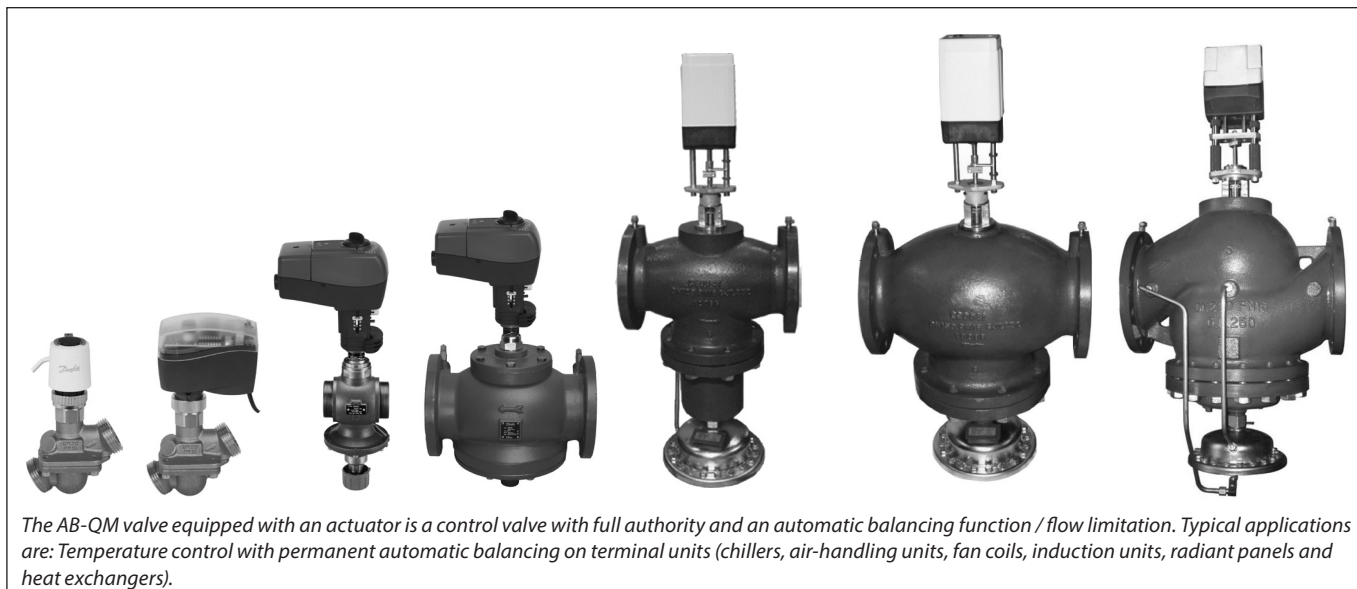

### Description

The **precise flow control performance** of the AB-QM with a Danfoss actuator provides increased comfort and **superior Total Cost of Ownership** because of savings made on:

- Efficient energy transfer and minimal pumping costs since there are no overflows at partial loads because of the exact pressure independent flow limitation.
  - Smaller pump investments and lower energy consumption as the pump head needed is lower than in the traditional setup. With the built in test plugs it is easy to troubleshoot and find the optimal setpoint for the pump.
  - Reduced movements of the actuator since the built-in differential pressure controller ensure the pressure fluctuations do not influence the room temperature.
  - Achieving a stable temperature in a room leading to a lower average temperature at the same comfort level.
  - Minimal flow complaints, as the valve performs as designed.
  - Minimal blockage complaints, as the membrane design makes AB-QM less susceptible to blockage than a cartridge type construction.
- Trouble-free segmentation of the building project. When sections of a project are finished they can normally not be handed over to the customer with a fully functional HVAC installation. However the AB-QM with a Danfoss actuator will automatically control the flow, even when other parts of the installation are still unfinished. The AB-QM doesn't need to be adjusted after finalisation of the project.
  - Commissioning costs are close to zero because of the convenient setting procedure that doesn't require flow charts, calculations or measuring equipment. The AB-QM valves can be set to a precise design value even when the system is up and running.
  - Lower installation costs as the AB-QM valve covers two functions, Balancing and Control.

**Control performance**

The AB-QM has a linear control characteristic. The AB-QM is pressure independent which means that the control characteristic is independent from the available pressure and is not influenced by a low authority. The flow limitation on the AB-QM is achieved by limiting the stroke and the Danfoss actuators calibrate to the stroke of the valves. This means that the AB-QM keeps its linear characteristic regardless of the setting or differential pressure.

Because of the predictable characteristic the actuators on the AB-QM can be used to change the response from linear to logarithmic (equal percentage). That makes the AB-QM suitable for all applications, including AHUs, where the equal percentage characteristic is needed to get a stable control loop. The actuators can be switched from linear to logarithmic by changing a dipswitch setting on the actuator.

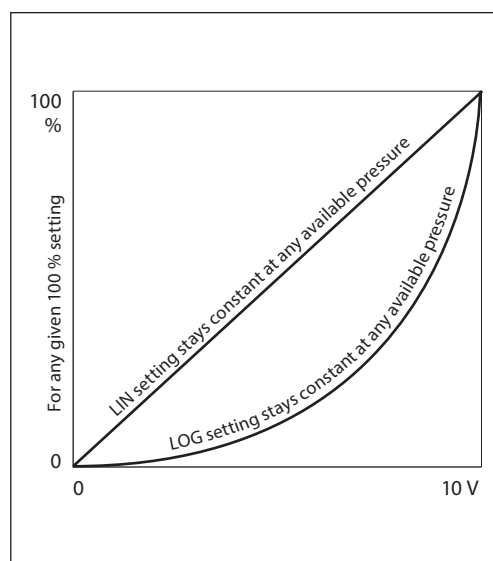

**Applications**

- variable flow systems

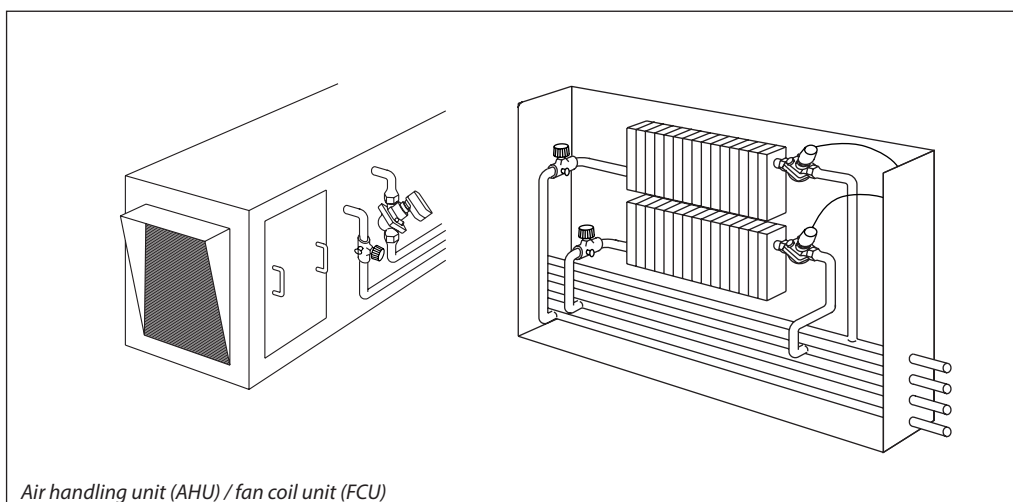

*Air handling unit (AHU) / fan coil unit (FCU)*

An AB-QM with a Danfoss actuator is used as a control valve for terminal units, like an AHU (Air Handling Unit), FCU (Fan Coil Unit) or radiation panel. The AB-QM ensures and controls the required flow on every terminal unit and maintains Hydraulic balance in the system.

Because of the integrated differential pressure controller the control valve always has 100 % authority and therefore always offers stable control. At partial load there is no overflow, contrary to conventional solutions, because the AB-QM will always limit the flow to exactly what is needed. By installing the AB-QM the whole system is divided in completely independent control loops.

There is a full range of Danfoss actuators available for the AB-QM, suitable for every control strategy. Actuators are available for On/Off, 0-10 Volt, 4-20 mA or floating point.

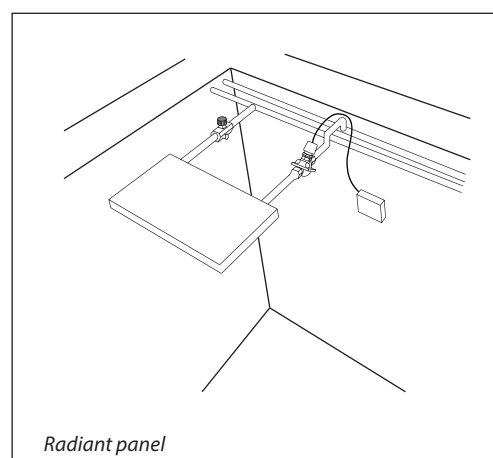

*Radiant panel*

**Applications**

- constant flow systems

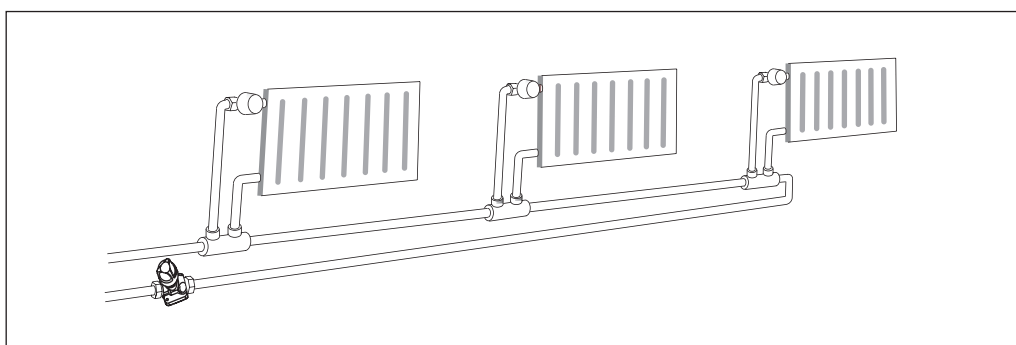
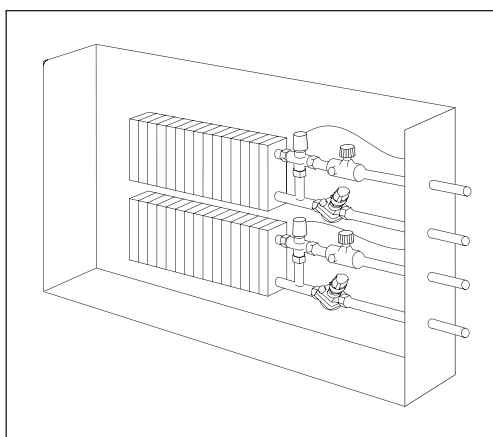

In constant flow systems with FCUs or in a one pipe heating system the AB-QM can be installed as an automatic balancing valve in every riser. The AB-QM limits the flow to the set value, thus automatically achieving hydronic balance in the system.

*There are numerous applications in which AB-QM can be used. Every time you need an automatic flow limiter or a control valve you can take advantage of the cost-saving properties of the AB-QM. This includes systems with (floor) heating/cooling, concrete core activation or radiant panels.*

**Note: For more application examples please contact your local Danfoss organization.**

**Easy implementation**

- No Kv or authority calculations needed. Flow is the only parameter to be considered when designing.
- The AB-QM always fits the application because the maximum setting of the AB-QM corresponds with international standards for flow velocity in pipes.
- The AB-QM can be used for all HVAC applications since it can have a linear or logarithmic characteristic when combined with thermal electric or gear actuators.
- Compact design, essential when only limited space is available. e.g. in fan-coil units.
- Easy commissioning. No specialized staff or measuring equipment are needed.
- Easy trouble shooting.
- Fast start-up because AB-QM valves don't need to be flushed or de-aired before use.
- Trouble-free segmentation of the building project. The AB-QM will automatically control the flow, even when parts of the installation are still unfinished. It's not necessary to adjust the AB-QM after finalisation of the building project.

**Ordering**
**AB-QM threaded version (with test plugs and without test plugs)**

Picture	DN	Q <sub>nom.</sub> (l/h)	Ext. thread (ISO 228/1)	Code No.	AB-QM	Ext. thread (ISO 228/1)	Code No.	
	10 LF	150	G ½A	<b>003Z126100</b>		G ½A	<b>003Z125100</b>	
	10	275		<b>003Z121100</b>			<b>003Z120100</b>	
	15 LF	275	G ¾A	<b>003Z126200</b>		<b>003Z125200</b>		
	15	450		<b>003Z121200</b>		<b>003Z120200</b>		
	20	900	G 1A	<b>003Z121300</b>		G 1A	<b>003Z120300</b>	
	25	1.700	G 1 ¼A	<b>003Z121400</b>		G 1 ¼A	<b>003Z120400</b>	
	32	3.200	G 1 ½A	<b>003Z121500</b>		G 1 ½A	<b>003Z120500</b>	
	40	7.500	G 2A	<b>003Z077000</b>		<i>AB-QM (DN 10-32) can not be upgraded to AB-QM with test plugs!</i>		
	50	12.500	G 2 ½A	<b>003Z076100</b>				

**AB-QM flanged version**

Picture	DN	Q <sub>nom.</sub> (l/h)	Flange connection	Code No.
	50	12,500	PN16	<b>003Z077200</b>
	65	20,000		<b>003Z077300</b>
	80	28,000		<b>003Z077400</b>
	100	38,000		<b>003Z077500</b>
	125	90,000		<b>003Z070500</b>
	125 HF	110,000		<b>003Z071500</b>
	150	145,000		<b>003Z070600</b>
	150 HF	190,000		<b>003Z071600</b>
	200	190,000		<b>003Z070700</b>
	200 HF	250,000		<b>003Z071700</b>
250	280,000	<b>003Z070800</b>		
250 HF	370,000	<b>003Z071800</b>		

Ordering (continued)

Accessories & spare parts

Type	Comments		Code No.
	To pipe	To valve	
Union connection (1 pcs.)  	R 3/8	DN 10	003Z023100
	R 1/2	DN 15	003Z023200
	R 3/4	DN 20	003Z023300
	R 1	DN 25	003Z023400
	R 1 1/4	DN 32	003Z023500
	R 1 1/2	DN 40	003Z027900
	R 2	DN 50	003Z027800
Shut-off & protection piece (max. closing pressure 16 bar)		DN 10-32	003Z123000
Shut-off - plastic (max. closing pressure 1 bar)			003Z024000
Handle AB-QM (necessary accessory if installing valve without actuator)		DN 40-100	003Z069500
		DN 125-250	003Z069600
Insulation Cap		DN10	003Z473000
		DN15	003Z473100
		DN20	003Z473200
		DN25	003Z473300
		DN32	003Z473400
		DN40	003Z473500
	DN50	003Z473600	
Locking Ring (5 pcs.)		DN 10-32	003Z123600
Adapter for AB-QM DN 10, G 1/2 internal thread for AB-QM, G 3/8 internal thread (1 pcs.)			003Z395400
Adapter for AB-QM DN 15, G 3/4 internal thread for AB-QM, G 3/4 external thread (1 pcs.)			003Z395500
Adapter for AB-QM DN 20, G 1 internal thread for AB-QM, G 1A external thread (1 pcs.)			003Z395600
Adapter for AB-QM DN 25, G 3/4 internal thread for AB-QM, G 3/4 external thread (1 pcs.)			003Z395700
Adapter AMV(E) 15/16/25/35 (AB-QM DN 40-100, 2nd. generation)			003Z069400
Stem heater for AB-QM DN 40-100 / AME 15 QM			065B217100
Stem heater for AB-QM DN 40-100 / AME 435 QM			065Z031500
Stem heater for AB-QM DN 125, 150 / AME 55 QM			065Z7022 00
Stem heater for AB-QM DN 200, 250 / AME 85 QM			065Z702100

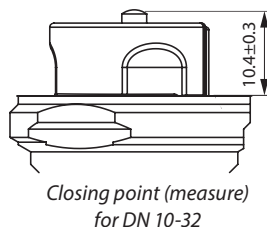

Combinations AB-QM with electrical actuators (AB-QM DN 10-100) <sup>1)</sup>

Valve type	Stroke (mm)	TWA-Z <sup>3)</sup>	AMI 140	ABNM	AMV 110/120 NL AME 110/120 NL	AME 435 QM
		Recommended ordering code numbers (for details refer to data sheets for these actuators)				
		082F138000 NC, 230 V	082H804800 AMI 140 24 V, 12 s/mm, 2-point control	082F116000 Thermal act. LOG 24 V (0-10 V)	082H805600 AMV 110 NL 24 V, 24 s/mm, 3-point control	082H017100 AME 435 QM 24 V
		082F138200 NC, 24 V			082H805700 AME 110 NL 24 V, 24 s/mm, 0-10 V	
DN 10-20	2.25	✓	✓	✓	✓	-
DN 25, 32	4.50	✓ <sup>2)</sup>	✓	✓ <sup>4)</sup>	✓	-
DN 40, 50	10	-	-	-	-	✓
DN 65-100	15	-	-	-	-	✓

<sup>1)</sup> Minimum recommended AB-QM setting is 20 %

<sup>2)</sup> up to 60 % of Q<sub>nom</sub>

<sup>3)</sup> Please be aware that only this type of TWA actuator is to be used with AB-QM

<sup>4)</sup> up to 60% of Q<sub>nom</sub>

Additional actuator's functionality available, for more info please contact your local Danfoss organization.

**Ordering (continued)**
**Combinations AB-QM with electrical actuators (AB-QM, DN 125-250)**

Valve type	Stroke (mm)	AME 55 QM	AME 85 QM
		Recommended ordering code numbers (for details refer to data sheets for these actuators)	
		082H307800 24 V, 8 s/mm, 0-10 V	082G145300 24 V, 8 s/mm, 0-10 V
DN 125	30	✓	-
DN 150	30	✓	-
DN 200	27	-	✓
DN 250	27	-	✓

Operational pressure for all AB-QM valves is 4 bar. Closing pressure for all actuators is 16 bar.  
Additional actuator's functionality available, for more info please contact your local Danfoss organization.

**Technical data**
**AB-QM (thread version)**

Nominal diameter		DN	10 Low Flow	10	15 Low Flow	15	20	25	32	40	50
Flow range	$Q_{nom}$ (100 %) <sup>1)</sup>	l/h	150	275	275	450	900	1.700	3.200	7.500	12.500
	$Q_{high}$ <sup>4)</sup>		180	330	330	540	1080	1.870 <sup>5)</sup>	3.520 <sup>5)</sup>	7.500	12.500
Setting range <sup>2)</sup>		%	20-120				20-110		40-100		
Diff. pressure <sup>3), 4)</sup>	$\Delta p_{Q_{nom}}$ ( $\Delta p_{Q_{high}}$ )	kPa	16-400 (18-400)				20-400 (25-400)		30-400		
Pressure stage		PN	16								
Control range		Acc. to standard IEC 534 control range is high as Cv characteristic is linear (1:1000)									
Control valve's characteristic		Linear (could be converted by actuator to equal percentage)									
Leakage acc. to standard IEC 534		No visible leakage (at 100N)								max. 0.05 % of $Q_{nom}$ at 500N	
For shut off function		Acc. to ISO 5208 class A - no visible leakage									
Flow medium		Water and water mixture for closed heating and cooling systems according to plant type I for DIN EN 14868. When used in plant Type II for DIN EN 14868 appropriate protective measures are taken. The requirements of VDI 2035, part 1 + 2 are observed.									
Medium temperature		°C	-10 ... +120								
Stroke		mm	2.25				4.5		10		
Connection	ext. thread (ISO 228/1)	G ½ A	G ½ A	G ¾ A	G ¾ A	G 1 A	G 1¼ A	G 1½ A	G 2 A	G 2½ A	
	actuator	M30 x 1.5								Danfoss standard	
<b>Materials in the water</b>											
Valve bodies		DZR Brass (CuZn36Pb2As - CW 602N)								Grey iron EN-GJL-250 (GG 25)	
Membranes and O-rings		EPDM									
Springs		W.Nr. 1.4568, W.Nr. 1.4310									
Cone (Pc)		W.Nr. 1.4305								CuZn40Pb3-CW 614N, W.Nr. 1.4305	
Seat (Pc)		EPDM									
Cone (Cv)		CuZn40Pb3 - CW 614N									
Seat (Cv)		DZR Brass (CuZn36Pb2As - CW 602N)								W.Nr. 1.4305	
Screw		Stainless Steel (A2)									
Flat gasket		NBR									
Sealing agent (only for valves with test plugs)		Dimethacrylate Ester									
<b>Materials out of the water</b>											
Plastic parts		PA								POM	
Insert parts and outer screws		CuZn39Pb3 - CW 614N; W.Nr. 1.4310; W.Nr. 1.4401									

<sup>1)</sup> factory setting of the valve is done at nominal setting range.

<sup>2)</sup> Regardless of the setting, the valve can modulate below 1% of set flow.

<sup>3)</sup>  $\Delta p = (P1 - P3) \text{ min} - \text{max}$

<sup>4)</sup> When set above 100%, minimum starting pressure needed is higher, see figures in the ().

<sup>5)</sup> When set above 100%, it can be used as a flow limiter only.

According suitability and usage especially in not oxygen tight systems please mind the instructions given by the coolant producer.

Pc - pressure controller part  
Cv - Control valve part

**Technical data (continued)**
**AB-QM (flange version)**

Nominal diameter		DN	50	65	80	100
Flow range	$Q_{nom}$ (100 %) <sup>1)</sup>	l/h	12.500	20.000	28.000	38.000
	$Q_{high}$ <sup>4)</sup>		12.500	20.000	28.000	38.000
Setting range <sup>2)</sup>		%	40-100			
Diff. pressure <sup>3), 4)</sup>	$\Delta p_{Qnom}$	kPa	30-400			
	$(\Delta p_{Qhigh})$		(30-400)			
Pressure stage		PN	16			
Control range		Acc. to standard IEC 534 control range is high as Cv characteristic is linear. (1:1000)				
Control valve's characteristic		Linear (could be converted by actuator to equal percentage)				
Leakage acc. to standard IEC 534		max. 0.05 % of $Q_{nom}$ at 500 N				
For shut off function		Acc. to ISO 5208 class A - no visible leakage				
Flow medium		Water and water mixture for closed heating and cooling systems according to plant type I for DIN EN 14868. When used in plant Type II for DIN EN 14868 appropriate protective measures are taken. The requirements of VDI 2035, part 1 + 2 are observed.				
Medium temperature		°C	-10 ... +120			
Stroke		mm	10	15		
Connection	flange	PN 16				
	actuator	Danfoss standard				
<b>Materials in the water</b>						
Valve bodies		Grey iron EN-GJL-250(GG25)				
Membranes/ Bellow		EPDM				
O-rings		EPDM				
Springs		W.Nr. 1.4568, W.Nr. 1.4310				
Cone (Pc)		CuZn40Pb3 - CW 614N, W.Nr. 1.4305				
Seat (Pc)		W.Nr. 1.4305				
Cone (Cv)		CuZn40Pb3 - CW 614N				
Seat (Cv)		W.Nr. 1.4305				
Screw		Stainless Steel (A2)				
Flat gasket		NBR				

Nominal diameter		DN	125	125 HF	150	150 HF	200	200 HF	250	250 HF
Flow range	$Q_{nom}$ (100 %) <sup>1)</sup>	l/h	90.000	110.000	145.000	190.000	190.000	250.000	280.000	370.000
	$Q_{high}$ <sup>4)</sup>		100.000	120.000	160.000	229.000	228.000	300.000	336.000	444.000
Setting range <sup>2)</sup>		%	40-110				40-120			
Diff. pressure <sup>3), 4)</sup>	$\Delta p_{Qnom}$	kPa	30-400	60-400	30-400	60-400	30-400	60-400	30-400	60-400
	$(\Delta p_{Qhigh})$		(50-400)	(80-400)	(50-400)	(80-400)	(50-400)	(80-400)	(50-400)	(80-400)
Pressure stage		PN	16							
Control range		Acc. to standard IEC 534 control range is high as Cv characteristic is linear.								
Control valve's characteristic		Linear (could be converted by actuator to equal percentage)								
Leakage acc. to standard IEC 534		max.0.01 % of $Q_{nom}$ at 650N			max. 0.01 % of $Q_{nom}$ at 1000N					
Flow medium		Water and water mixture for closed heating and cooling systems according to plant type I for DIN EN 14868. When used in plant Type II for DIN EN 14868 appropriate protective measures are taken. The requirements of VDI 2035, part 1 + 2 are observed.								
Medium temperature		°C	-10 ... +120							
Stroke		mm	30	30	27	27				
Connection	flange	PN 16								
	actuator	Danfoss standard								
<b>Materials in the water</b>										
Valve bodies		Grey iron EN-GJL-250 (GG 25)								
Membranes/ Bellow		W.Nr.1.4571	EPDM							
O-rings		EPDM								
Springs		W.Nr.1.4401	W.Nr.1.4310							
Cone (Pc)		W.Nr.1.4404NC	W.Nr.1.4021							
Seat (Pc)		W.Nr.1.4027								
Cone (Cv)		W.Nr.1.4404NC	W.Nr.1.4021							
Seat (Cv)		W.Nr.1.4027								
Screw		W.Nr.1.1181								
Flat gasket		Graphite gasket	Non asbestos							

<sup>1)</sup> factory setting of the valve is done at nominal setting range.

<sup>2)</sup> Regardless of the setting, the valve can modulate below 1% of set flow.

<sup>3)</sup>  $\Delta p = (P1 - P3) \text{ min} \sim \text{max}$

<sup>4)</sup> When set above 100%, minimum starting pressure needed is higher, see figures in the ().

Pc - pressure controller part

Cv - Control valve part

**Design**

- 1 Spindle
- 2 Stuffing box
- 3 Pointer
- 4 Control valve's cone
- 5 Membrane
- 6 Main spring
- 7 Hollow cone (pressure controller)
- 8 Vulcanized seat (pressure controller)

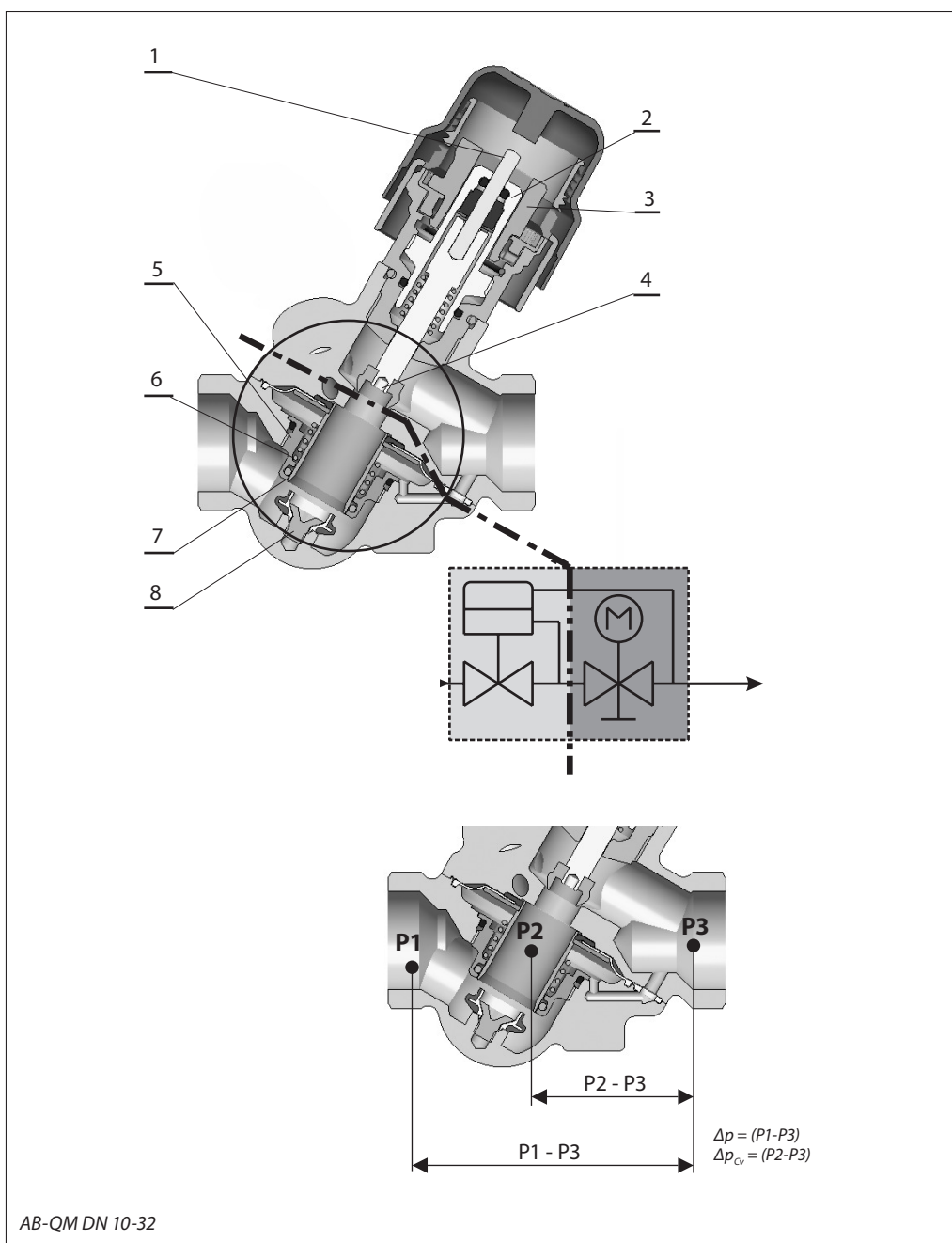

**Function:**

The AB-QM valve consists of two parts:

- 1. Differential pressure controller
- 2. Control valve

**1. Differential pressure controller DPC**

The differential pressure controller maintains a constant differential pressure across the control valve. The pressure difference  $\Delta p_{cv}$  ( $P2 - P3$ ) on the membrane is balanced with the force of the spring. Whenever the differential pressure across the control valve changes (due to a change in available pressure, or movement of the control valve) the hollow cone is displaced to a new position which brings a new equilibrium and therefore keeps the differential pressure at a constant level.

**2. Control valve Cv**

The control valve has a linear characteristic. It features a stroke limitation function that allows adjustment of the  $K_v$  value. The percentage marked on the scale equals the percentage of 100 % flow marked on the pointer. Changing the stroke limitation is done by lifting the blocking mechanism and turning the top of the valve to the desired position, shown on the scale as a percentage. A locking mechanism automatically prevents unwanted changing of the setting.



Design (continued)

1. Shut off screw
2. Main spring
3. Membrane
4. DP cone
5. Seat
6. Valve body
7. Control valves cone
8. Locking screw
9. Scale
10. Stuffing box
11. Spindle

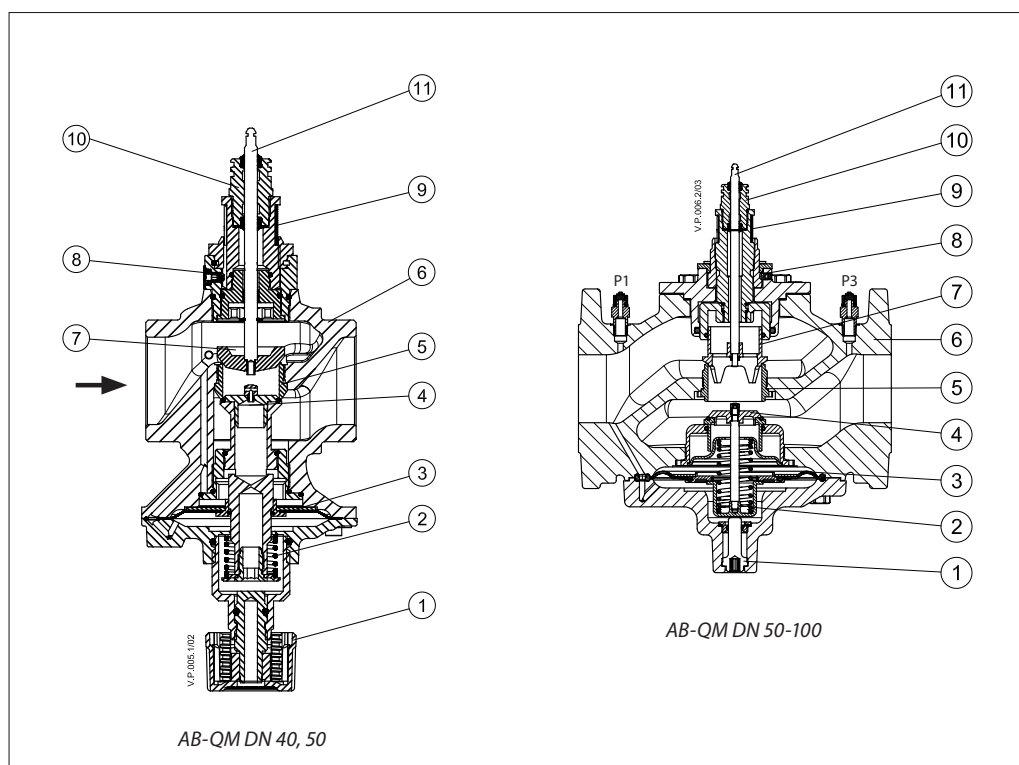

1. Valve body
2. Valve seat
3. DPC cone
4. CV cone
5. Controller casting
6. Rolling diaphragm
7. Adjusting screw
8. Bellow for pressure relief on DPC cone

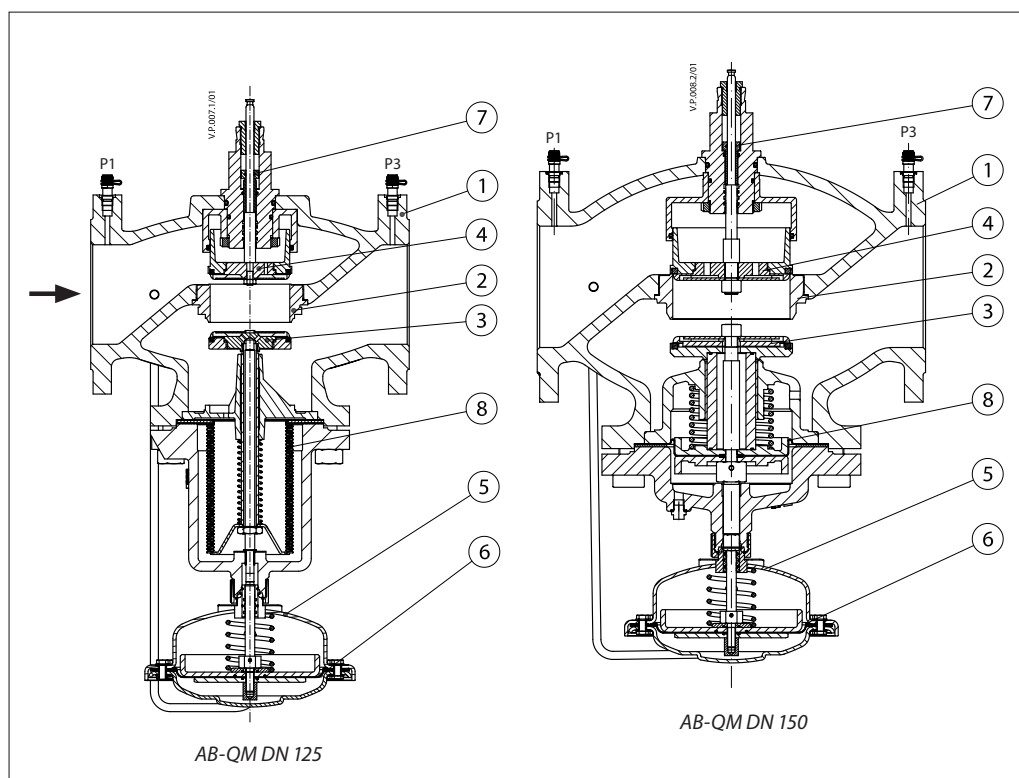

Design (continued)

1. Valve body
2. Valve seat
3. DPC cone
4. CV cone
5. Controller casting
6. Rolling diaphragm
7. Adjusting screw
8. Bellow for pressure relief on DPC cone

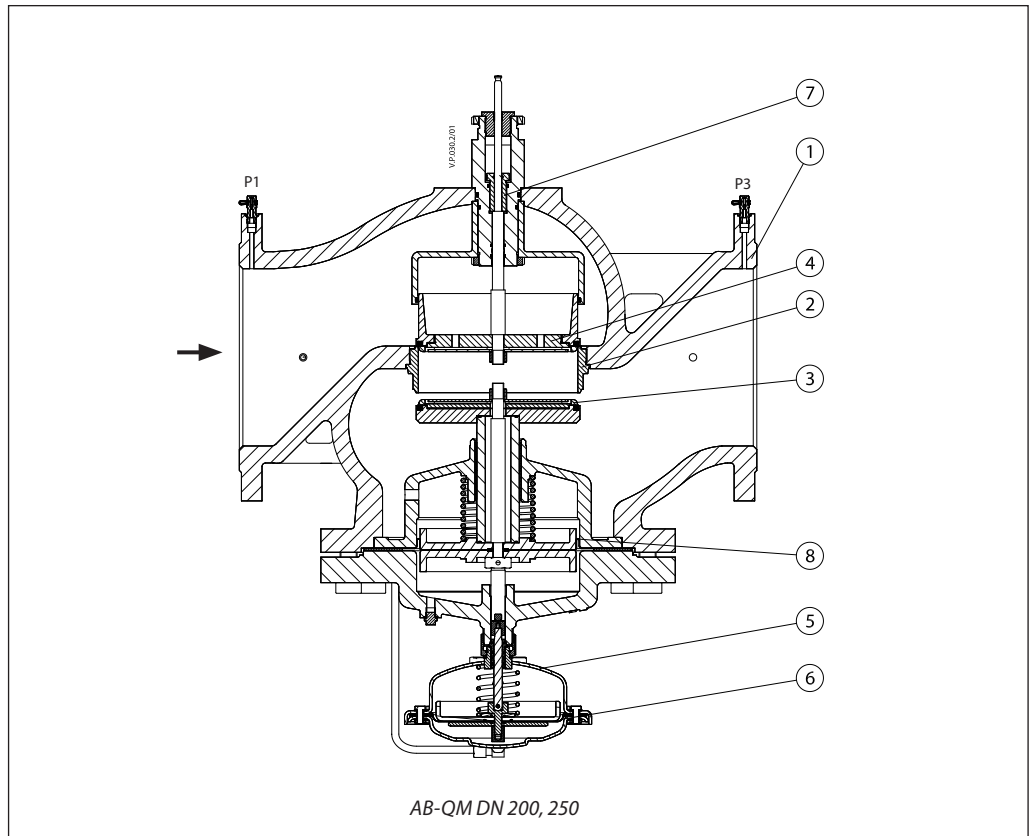

Sizing

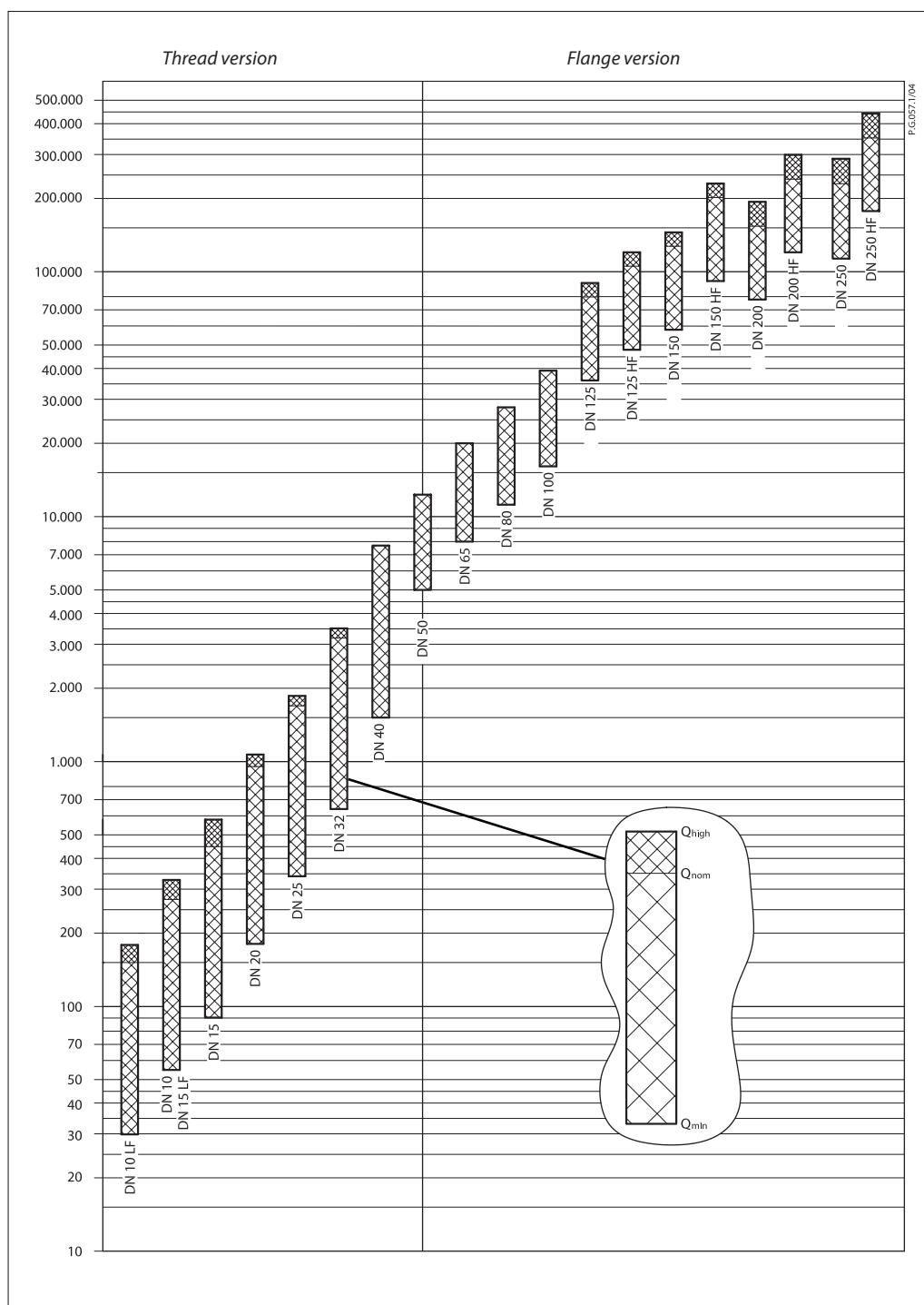

Sizing (continued)

**Example 1: Variable flow system**

Given:

Cool requirement per unit : 1000 W  
 Flow temperature in the system: 6 °C  
 Return temperature in the system: 12 °C

Required - control and balancing valves:

AB-QM and actuators type for BMS system.

Solution:

Flow in the system: Q (l/h)  
 $Q = 0.86 \times 1000 / (12 - 6) = 143 \text{ l/h}$

Selected:

AB-QM DN 10 mm with  $Q_{nom} = 275 \text{ l/h}$  presetting on  $143/275 = 0.52 = 52\%$  of nominal opening.  
 Actuators: AMV 110NL - 24 V

Remarks:

required minimum differential pressure across the AB-QM DN 10: 16 kPa.

**Example 2: Constant flow system**

Given:

Cool requirement per unit : 4000 W  
 Flow temperature in the system : 6 °C  
 Return temperature in the system : 12 °C

Required - automatic flow limiter:

AB-QM and presetting.

Solution:

Flow in the system : Q (l/h)  
 $Q = 0.86 \times 4000 / (12 - 6) = 573 \text{ l/h}$

Selected:

AB-QM DN 20 mm with  $Q_{nom} = 900 \text{ l/h}$  presetting on  $573/900 = 0.64 = 64\%$  of maximum opening.

Remarks:

required minimum differential pressure across the AB-QM DN 20: 16 kPa.

**Example 3: Sizing AB-QM according pipe dimension**

Given:

Flow in system 1.4 m<sup>3</sup>/h (1400 l/h = 0.38l/s), pipe dimension DN 25 mm

Required - automatic flow limiter:

AB-QM and presetting.

Solution:

In this case we have selected the AB-QM DN 25 mm with  $Q_{nom} = 1700 \text{ l/h}$

In this case it will be recommended to check the maximum velocity in the pipe. For this we calculate velocity in the pipe for condition:  
 DN 25 mm – Di 27.2 mm

Dimension and condition acceptable, velocity below 1.0 m/s.

Presetting on the valve AB-QM DN 25 mm  $1400/1700 = 0.82 = 82\%$  of nominal opening.

Remarks:

required minimum differential pressure across the AB-QM DN 25: 20 kPa.

Pump optimising /  
Trouble shooting

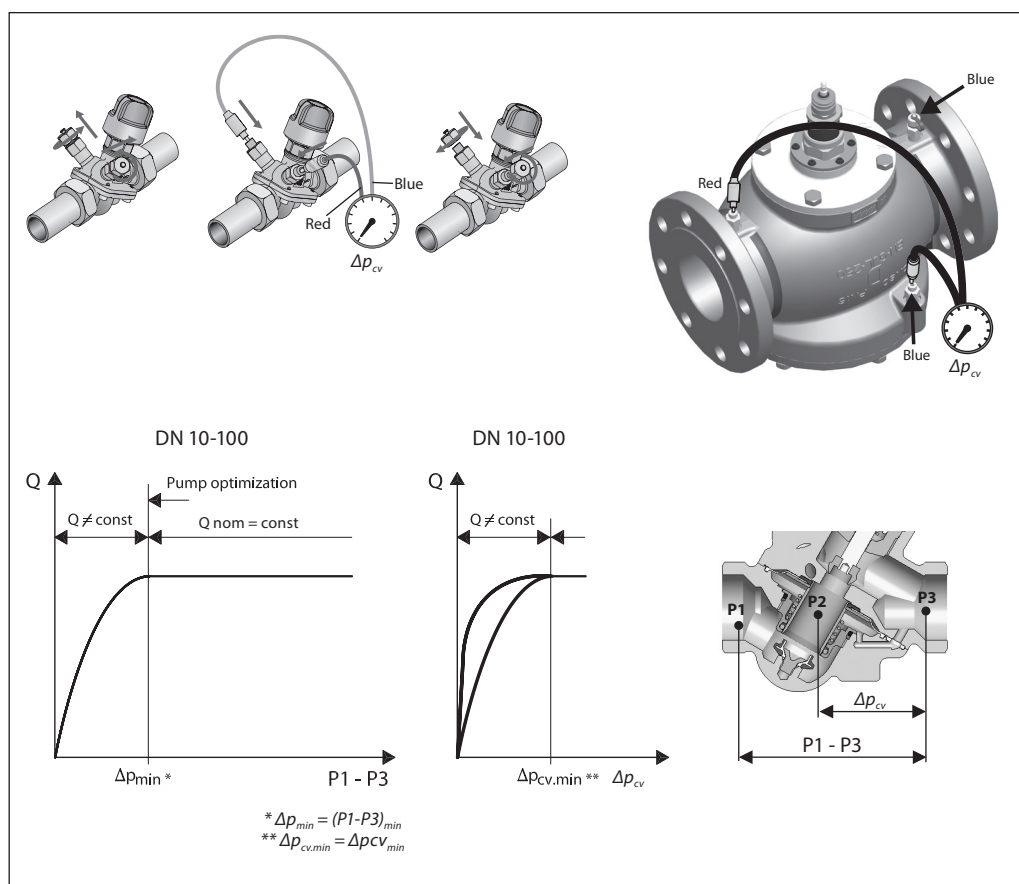

The AB-QM (DN 10-100) features test plugs that allow measuring of the pressure difference  $\Delta p_{cv}$  across the control valve while AB-QM (DN 125-250) measuring is done between P1 and P3. If the pressure difference exceeds the minimum required pressure the valve is operational and the flow limitation is achieved. The measuring function can be used to verify if enough pressure difference is available and thus verify the flow or measure the flow directly (only for DN40-100). For detailed information on how to measure flow on DN40-100 valves, please refer to the Flow checker document VF.A7.A1.02.

It can also be used to optimize the pump head. The pump head can be decreased until no more than the minimum required pressure is available on the most critical valve (in terms of hydronic). This optimal point is found when proportionality between the pump head and the measured differential pressure cease to exist. Verifying the pressure can be done by using for example a Danfoss PFM device (for more details please refer to AB-QM Tech Note).

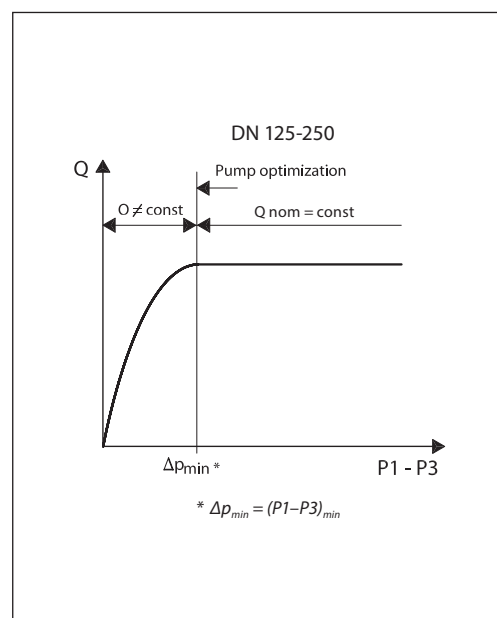

**Presetting**  
DN 10-32

The calculated flow can be adjusted easily without using special tools.

To change the presetting (factory setting is 100%) follow the four steps below:

- Remove the blue protective cap or the mounted actuator
- Raise the grey pointer
- Turn (clockwise to decrease) to the new pre-setting
- Push the grey pointer back into the lock position. After it clicks pre-setting is locked.

The presetting scale indicates a value between 100 % flow to 0 %. Turning the cap clockwise decreases the flow value while counter clockwise increases it.

If the valve is a DN 15 then the nominal flow = 450 l/h = 100 % presetting. To set a flow of 270 l/h you have to set:  $270/450 = 60\%$ .

Danfoss recommends a pre-setting/flow from 20 % to 100 %. Factory presetting is 100 %.

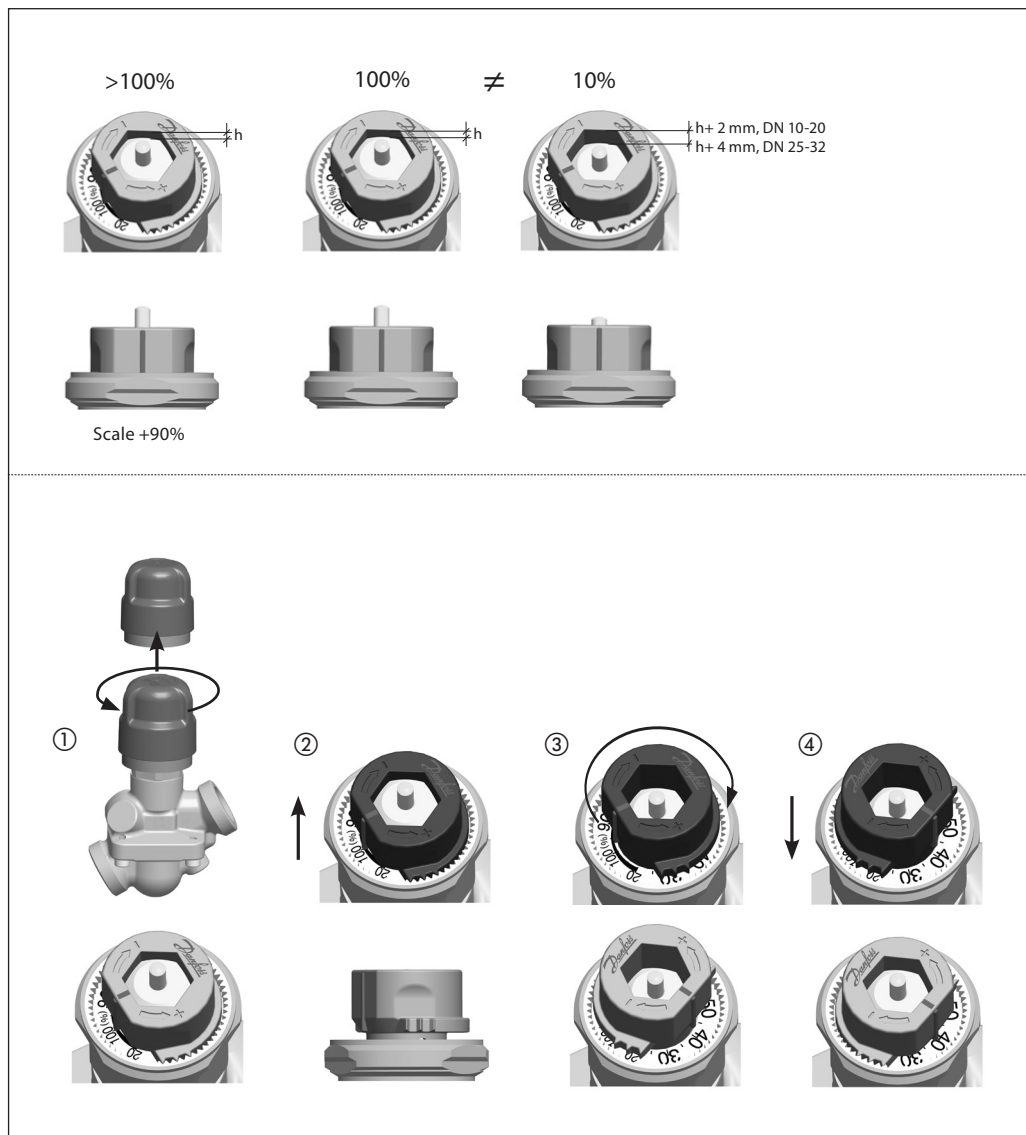

Pre-setting (continued)

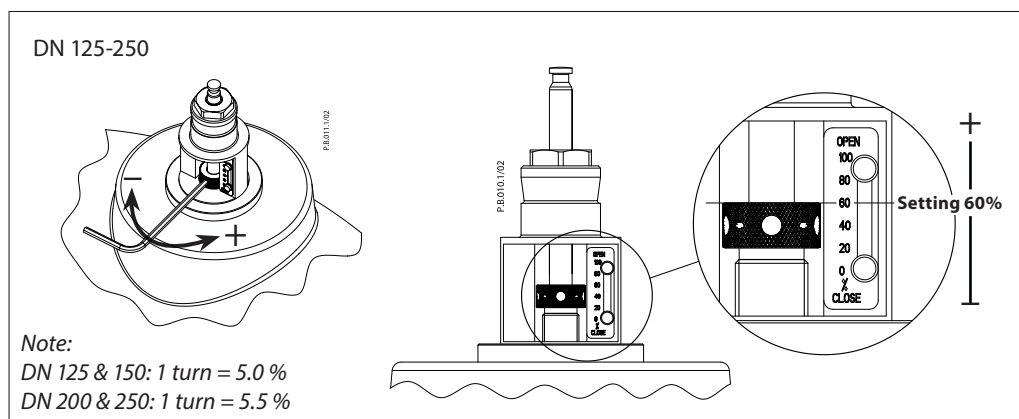
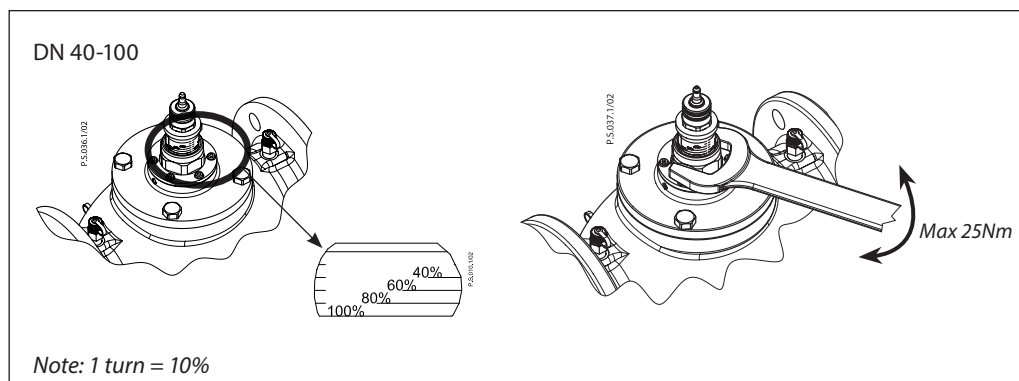

Service

DN 10-32

For the service shut off function, it is recommended to install the valve in the supply water pipe.

Valves are equipped with a plastic shut-off mechanism that is used as an isolating function up to 1 bar differential pressure. When closing against higher differential pressure a shut-off & protection cap is available as an accessory (code: 003Z123000) or set the value to 0%.

DN 40-100

For the service shut off function, the valve can be installed in either the supply or return pipe.

Valves are equipped with manual shut-off for isolating function up to 16 bar.

Installing

The AB-QM valve is mono-directional meaning that the valve operates when the arrow on the valve body is aligned with the flow direction. When this rule is disobeyed the valve acts like a variable orifice that causes water hammer on sudden closing when the available pressure has increased or the valve have been set to a lower value.

When system conditions allow backflow it is strongly recommended to use a backflow preventer in order to avoid possible water hammer that can damage the valve as well as other elements in the system.

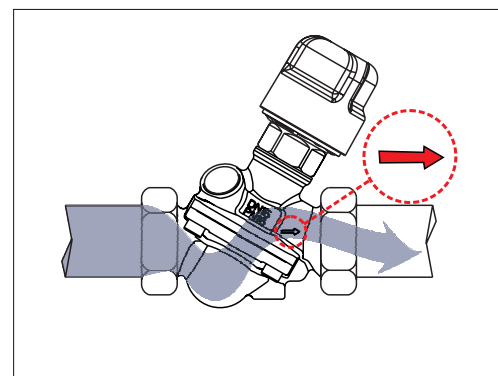

Tender text

1. The pressure independent balancing and control valve should be comprised of a linear control valve and an integrated membrane based pressure controller.
2. The pressure independent balancing and control valve should be available in the range from DN 10- 250.
3. The valve could be used as an automatic flow limiter.
4. The valve should have a mechanism (flow setting) to adjust the flow stepless from 100 to 0 % of the nominal flow.
5. Minimum possible flow pre-setting should be 30l/h.
6. At the minimum setting modulation below 1% should be possible.
7. Shut off service function should be possible with setting mechanism.
8. The adjustment should be performed without a tool for dimensions up to DN 32 or a standard tool for valves bigger than DN 32.
9. The setting, which can be locked, should be visible from the top for valves DN 32 and from the side for DN 100.
10. The valves should have a shut-off function, separated from the setting mechanism, for valves DN 40-100.
11. The leakage rate should be: No visible leakage at force of the thermal actuator (90 N) for valves up to DN 32. Leakage of 0.05 % of the Qnom for valves up to DN 100 and up DN 250 at 500N and 1.000N respectively. All actuators should be able to close against 16 bar of differential pressure.
12. The authority of the pressure independent control valve should be 1 at all settings (control valve characteristic is not changed).
13. Control valve should have linear flow characteristic at all settings. **(Supplier of the valve should provide lab test results <sup>1)</sup>).**
14. Control ratio of the pressure independent balancing and control valve should be higher than 1:1000
15. Control valve should have the possibility to change linear characteristic to equal percentage characteristic at all sizes and settings by adjusting actuator settings.
16. Minimum starting differential pressure for flow limitation should be 16 kPa for valves up to DN 20, 20 kPa valves up to DN 32 and 30 kPa for valves up to DN250. (Supplier of the valve should provide lab test results <sup>1)</sup>). Nominal pressure rating 16 bar.
17. Test plug for pump optimization and flow verification should be available for DN 10-250.
18. Valve sizes from DN10-DN250 should be available from one supplier.

Nominal diameter: \_\_\_\_\_  
 Connection: \_\_\_\_\_  
 Adjustment range from - to \_\_\_\_\_ m<sup>3</sup>/h  
 Produced by: Danfoss  
 Type: AB-QM  
 Ordering no.: 003Z \_\_\_\_\_

<sup>1)</sup> Since there is no standard for testing procedure, Danfoss recommends verification by independent lab to compare control and flow limitation function of different PIBCVs at the same basis.



Dimensions

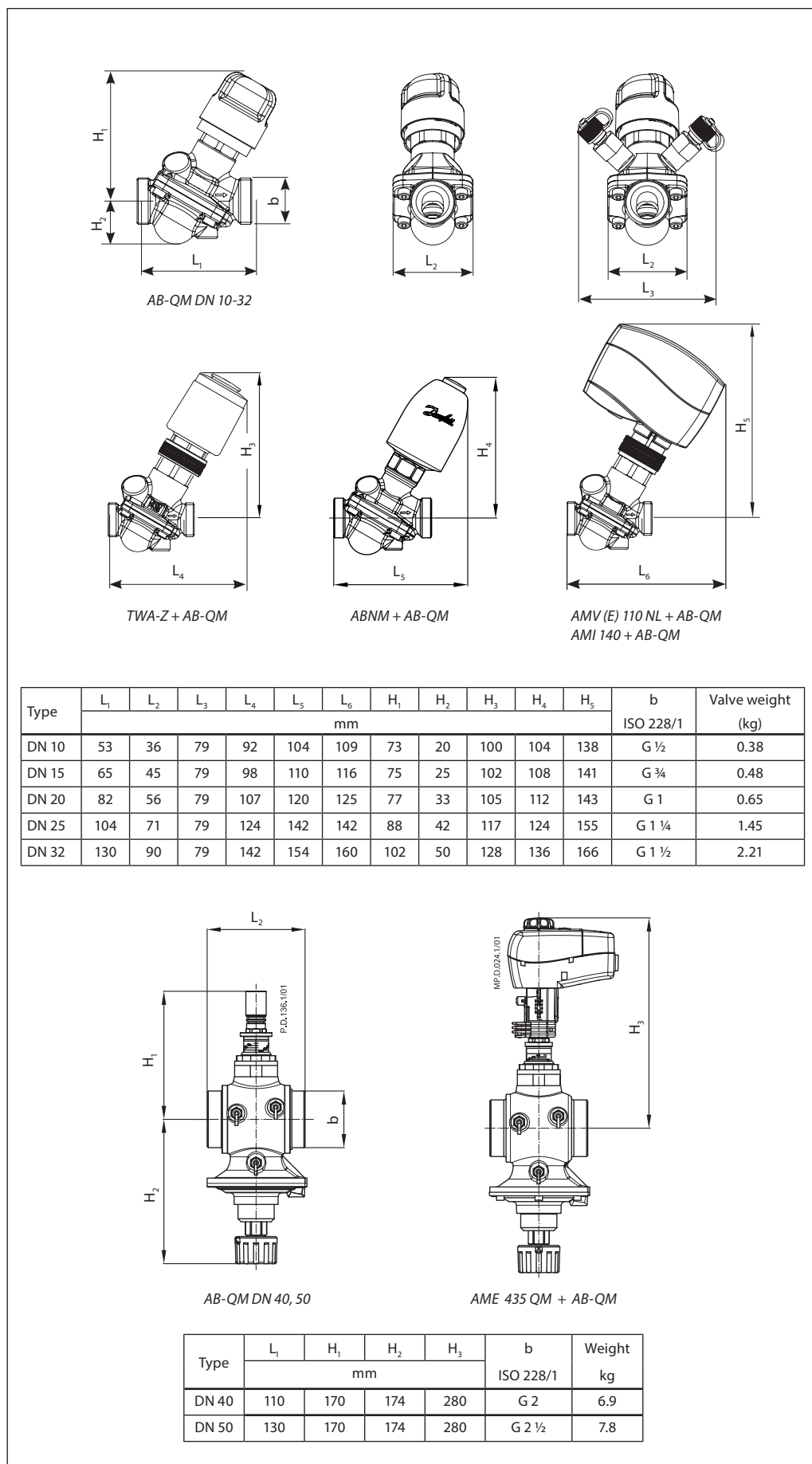

Dimensions (continued)

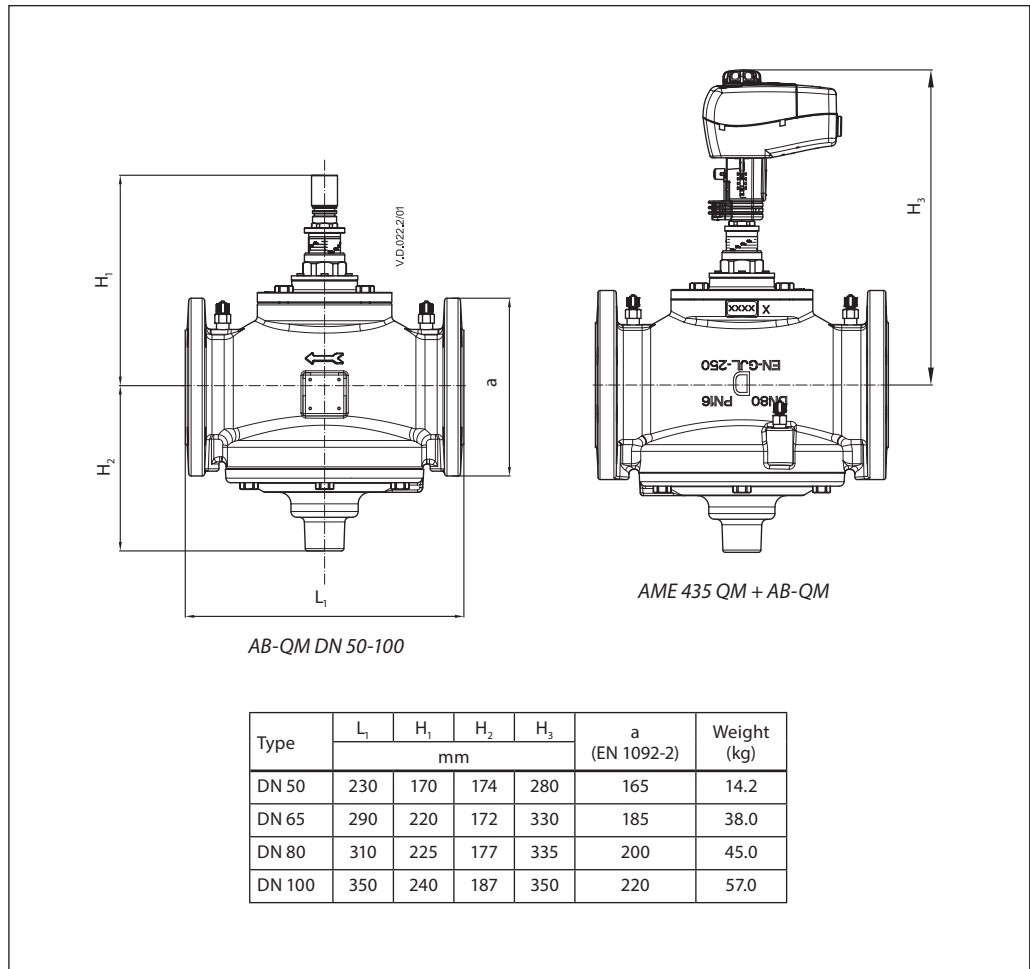

Dimensions (continued)

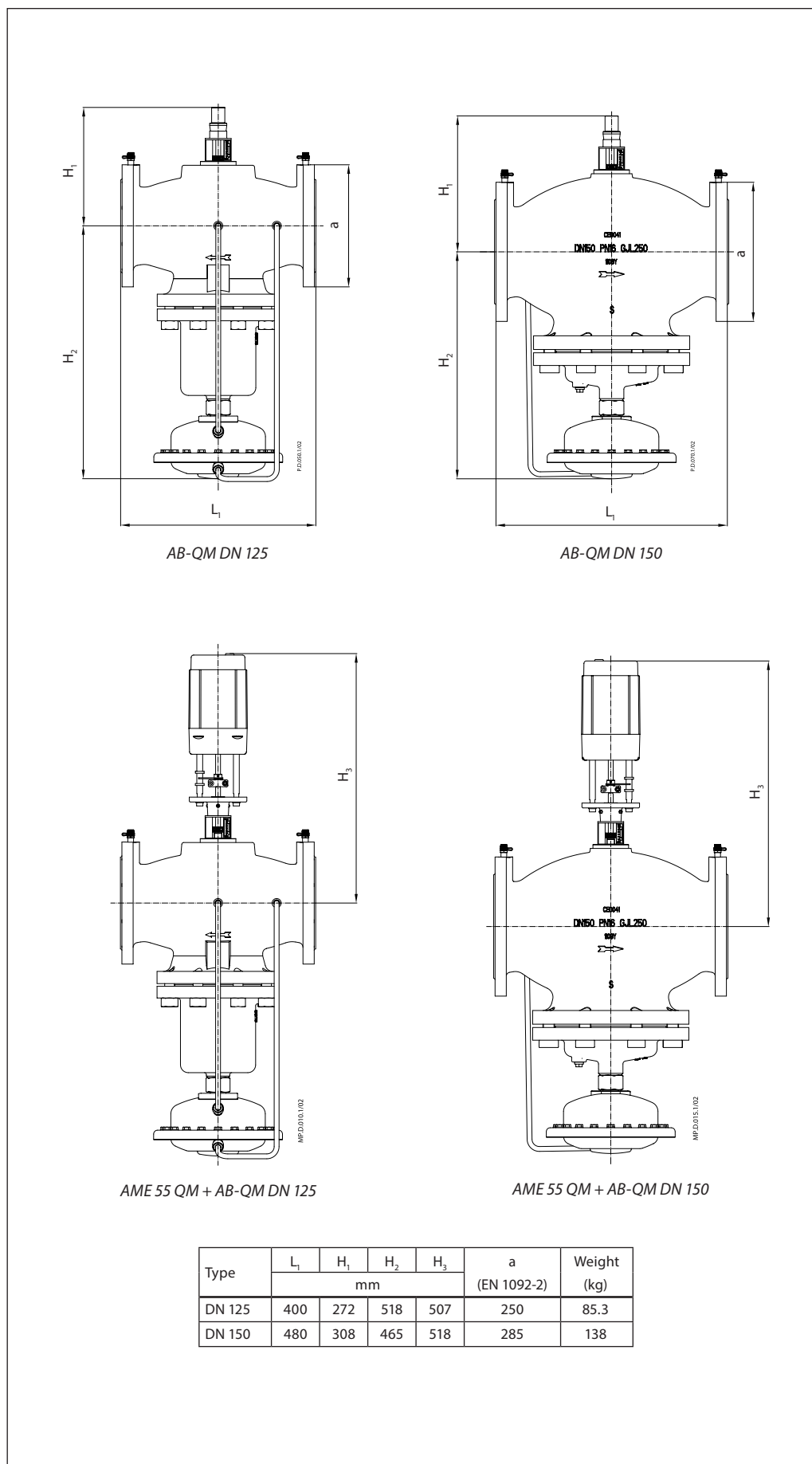

Type	L <sub>1</sub>	H <sub>1</sub>	H <sub>2</sub>	H <sub>3</sub>	a (EN 1092-2)	Weight (kg)
	mm					
DN 125	400	272	518	507	250	85.3
DN 150	480	308	465	518	285	138

Dimensions (continued)

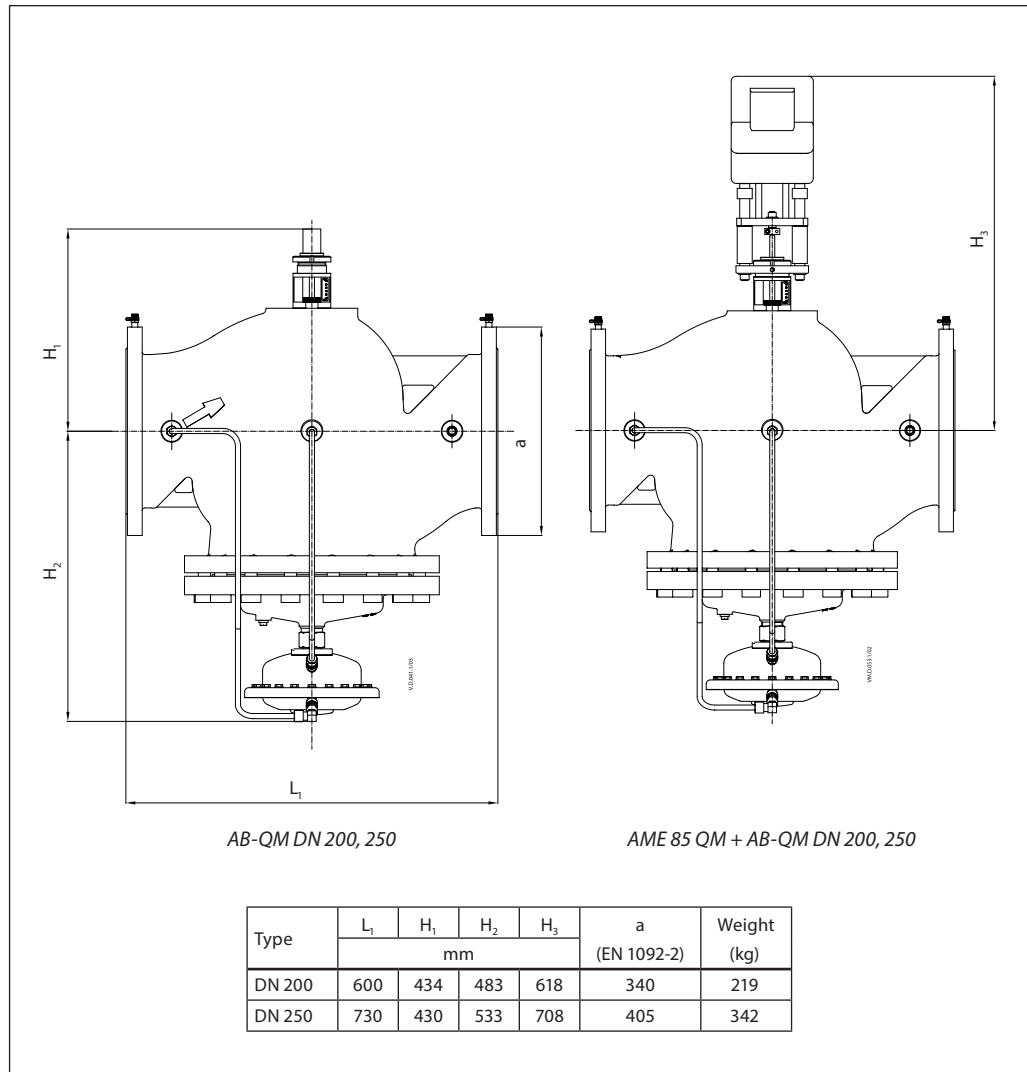

Danfoss can accept no responsibility for possible errors in catalogues, brochures and other printed material. Danfoss reserves the right to alter its products without notice. This also applies to products already on order provided that such alterations can be made without consequential changes being necessary in specifications already agreed. All trademarks in this material are property of the respective companies. Danfoss and the Danfoss logotype are trademarks of Danfoss A/S. All rights reserved.