

Application Guide

# ICFD defrost module

## Supplemental application guidelines

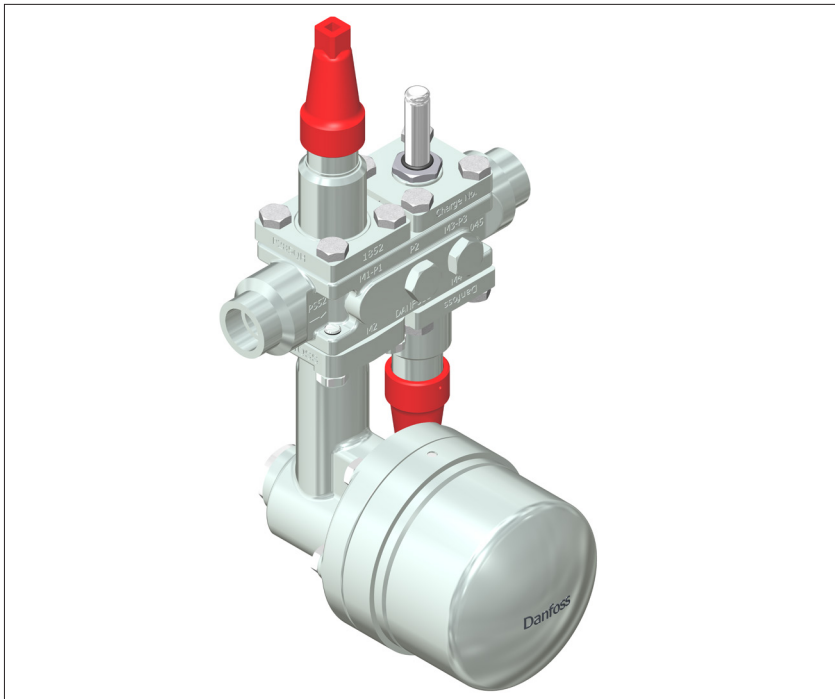

This ICFD supplemental application guide describes the special requirements to be taken into account when designing the liquid drain line with ICFD defrost module.

### ICF valve station with ICFD module connected to the evaporator

Figure 1 shows the most common evaporator types.

If defrost is planned to be done using the ICFD liquid drain method, **all types** of evaporators must be connected to the ICF valve station with the same piping configuration.

- **Condensate drain outlet at the lowest pipe of the evaporator.**
- **Hot gas inlet at the top pipe of the evaporator**

The ICFD module is designed for drainage of primarily liquid. The gas in the system at start-up of the defrost process is drained only through a small gas by-pass orifice, built into the ICFD module.

It is therefore very important to get and keep the refrigerant in liquid phase.

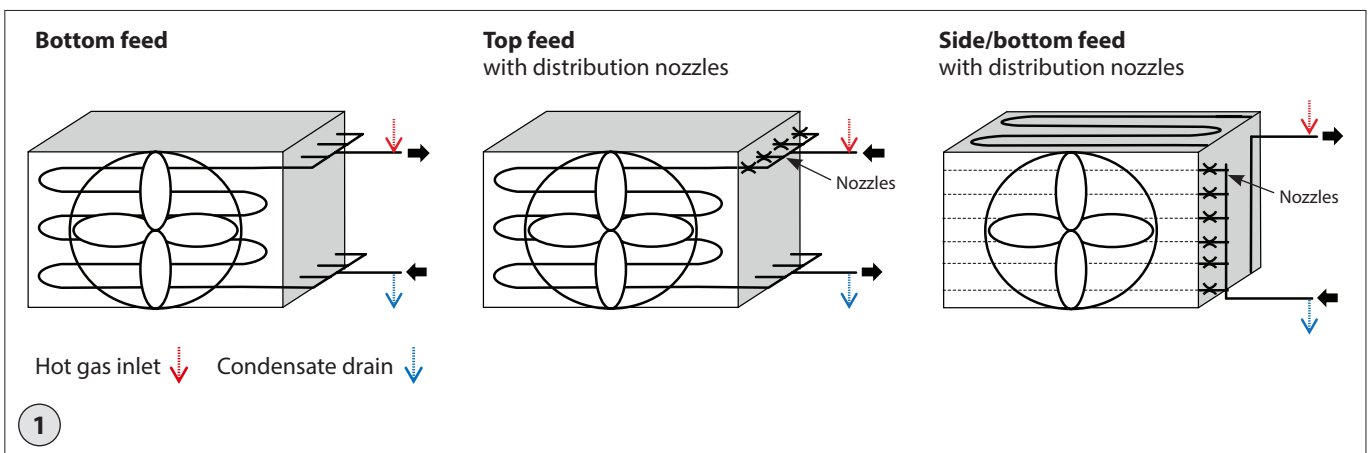

### Drain line

During piping layout, take all precautions to minimize the pressure drop to avoid flash gas. Any pressure loss will reduce the liquid drain capacity.

For Evaporators with distribution nozzles at the drain outlet (side/bottom feed in fig. 1), the liquid passing the nozzles during defrost will create a certain pressure drop in the drain line. This pressure drop must be taken into account when determining the total pressure loss.

To minimize total pressure drop the lifting height of the liquid should not exceed 5 m (16.5 ft) (see figure 2 and 3).

To calculate the complete pressure drop for ICF with ICFD included the Danfoss selection tool Coolselector®2 is recommended.

Always install a P-trap at the drain line connection to the evaporator to collect the liquid.

**Drain line (continued)**

The optimum piping layout for the liquid drain line is a separate line for the defrost drain (see fig. 2). By this set-up the dimensions of the liquid drain pipe can be determined for optimized liquid velocity and liquid volume and thereby reducing pressure loss.

Fig. 3 shows alternative piping layouts for the defrost liquid line. An acceptable option is to use the existing liquid line provided that a P-trap is installed

**Hot gas line**

During piping layout, take all precautions to minimize the pressure drop in the hot gas line to ensure sufficient defrost pressure (temperature) in the evaporator. Any pressure loss may reduce the defrost capacity.

For evaporators with distribution nozzles at the hot gas entrance (top feed in fig. 1), the gas passing the nozzles during defrost will create a certain pressure drop in the hot gas line. This pressure drop must be taken into account when determining the total pressure loss.

For calculation and optimizing of the pressure losses in both liquid drain line and hot gas line the Danfoss selection tool Coolselector®2 is recommended.

The liquid drain setup with ICFD does not include any control of the pressure during defrost. It is therefore recommended to consider the following:

If the hot gas supply pressure is higher than the pressure required for defrosting, it is recommended to install a pressure reducing valve like ICS/CVC ahead of the hot gas valve station to prevent too high hot gas pressure entering and potentially damaging the evaporator. The CVC should be set to the pressure intended for the defrost process (see fig. 2 and 3).

For ultimate pressure relief it is recommended to install a BSV safety valve in parallel with the wet return ICFV valve station (see fig. 2 and 3).

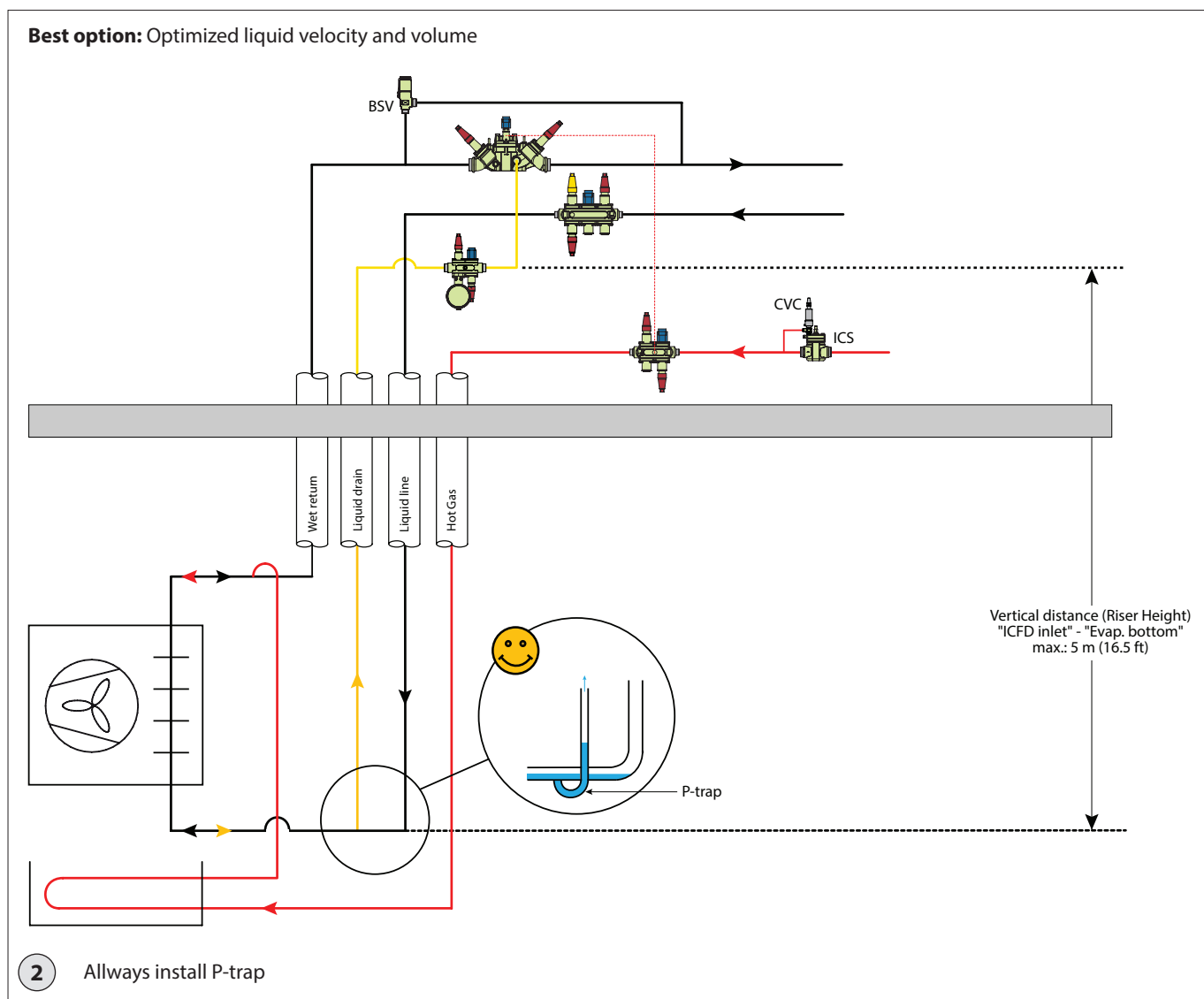

Hot gas line (continued)

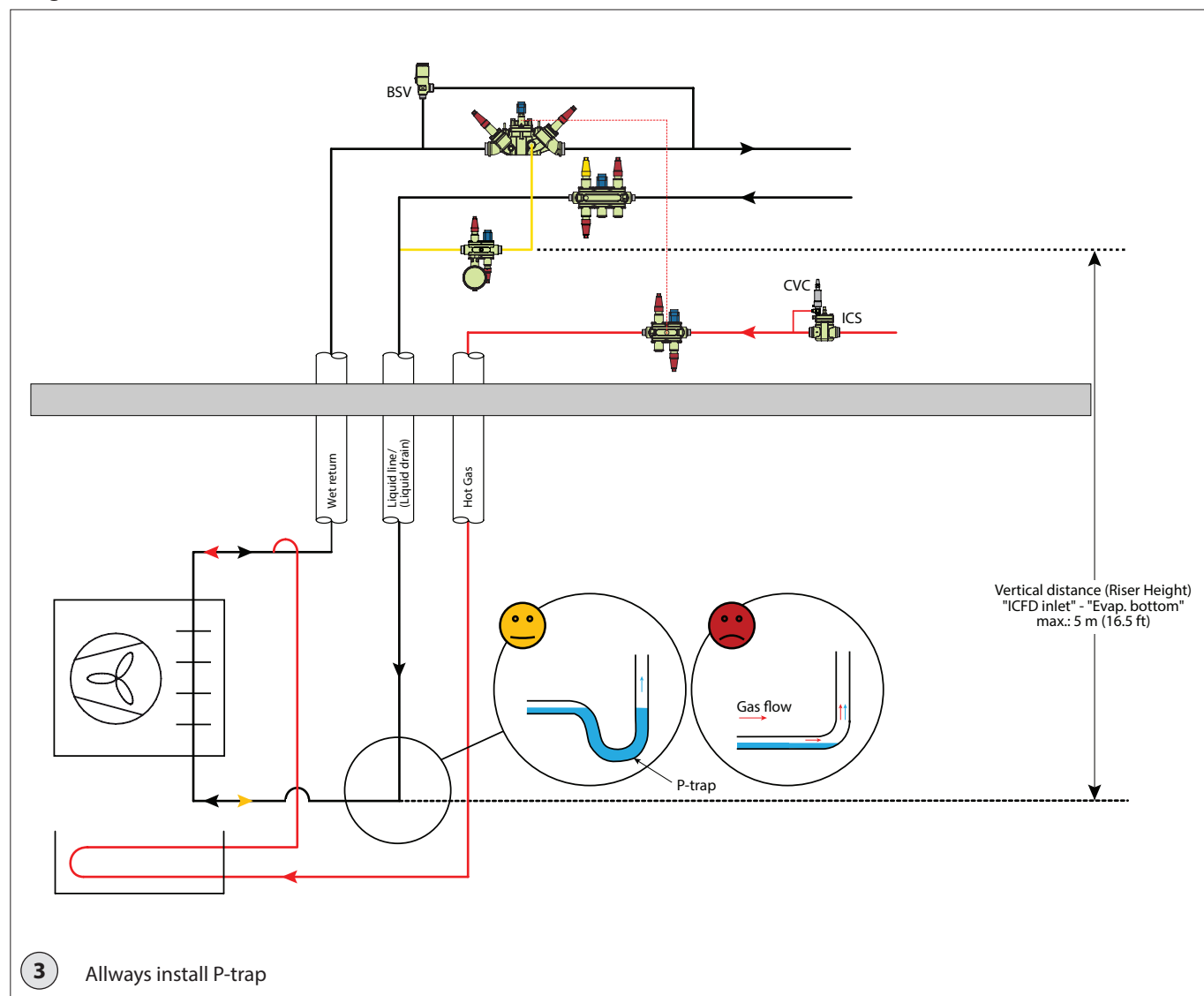

ENGINEERING  
TOMORROW



---

Danfoss can accept no responsibility for possible errors in catalogues, brochures and other printed material. Danfoss reserves the right to alter its products without notice. This also applies to products already on order provided that such alterations can be made without subsequential changes being necessary in specifications already agreed. All trademarks in this material are property of the respective companies. Danfoss and the Danfoss logotype are trademarks of Danfoss A/S. All rights reserved.