

Article

k_v : what, why, how, whence?

Herman Boysen, Product Application Manager, Danfoss A/S



k_v: what, why, how, whence?



What?

The k_v-factor for a given valve is a constant which in a simple way states the valve capacity. The k_v-factor is determined by the valve manufacturer by experiments. The k_v-factor specifies the water flow in m³ through the valve in one hour at a pressure drop across the valve of 1 Bar.

Why?

The k_v-factor is an exact and easily applicable value for use when calculating pressure drops, sizing, and ordering valves.

How?

Imagine that you are going to size a motorised valve for a room heating system in a District Heating Network (fig. 1). The calculated flow rate Q is 1,8 l/sec = 6,5 m³/h. And the pressure drop Δp available for the motorised valve is 50 kPa = 0,50 bar. By using the formula

$$k_v = \frac{Q}{\sqrt{\Delta p}} \text{ m}^3 / \text{h}$$

the desired k_v value can be calculated.

$$k_v = \frac{6,5}{\sqrt{0,50}} = 9,2 \text{ m}^3 / \text{h}$$

From the datasheets you will see that a VM2 or VB2 with the k_{vS} = 10 m³/h can be used.

Whence?

The concept of k_v originates from USA and was published for the first time in November 1944. However, kv is not used in USA but is replaced by C_v. C_v stands for Valve Flow Coefficient. In English C_v is today mostly described as C_v-factor or flow factor C_v. To make the confusion complete, there is not one but two C_v-factors, because the American and the English measuring systems are not quite identical. If you wish to avoid any misunderstanding, and you should always try to do so today where even the smallest piece of information will find its way to the remotest places of the world, it is necessary to state the type of gallon used, C_v US indicates the water flow in US gallons through the valve in one minute at a pressure drop across the valve of one pound per square inch. C_v UK indicates the water flow in UK gallons through the valve in one minute at a pressure drop across the valve of one pound per square inch. One US gallon = 3.785 litres and one UK gallon = 4.546 litres. The other American and British units are identical. One pound per square inch is written 1 lb/in² = 1 psi. The k_v-factor – or the kv-value as it is also called – is defined in VDI/VDE Richtlinien No. 2173.

A simplified version of the definition is: The k_v-factor of a valve indicates the water flow in m³/h at a pressure drop across the valve of 1 kg/cm² when the valve is completely open. The complete definition also says that the flow medium must have a specific gravity of 1000 kg/m³ and a kinematic viscosity of 10–6 m²/s. Water for heating systems satisfies these conditions with sufficient accuracy. This is the reason that the subsequent summary of formula can be made simple and clear.

Some theory

The concept of k_v is based on the hydrodynamic law saying that the pressure drop (Δp) in a valve, s in any resistance to flow, is proportional to the square on the flow volume (Q): Δp ~ proportional to Q². If we take a few concrete examples, the ratio between these can be written:

$$\frac{\Delta p_1}{Q_1^2} = \frac{\Delta p_2}{Q_2^2}$$

or

$$\frac{\Delta p_1}{\Delta p_2} = \frac{Q_1^2}{Q_2^2}$$

or

$$Q_1 = Q_2 \sqrt{\frac{\Delta p_1}{\Delta p_2}}$$

Since the definition of k_v says that the k_v-factor indicates the capacity through the valve at a pressure drop of Δp = 1 Bar, we can put Q₂ = kv and p₂ = 1 Bar. 100 kPa = 1 Bar.

$$Q_1 = k_v \sqrt{\frac{\Delta p_1}{\Delta p_2}}$$

then has the form

$$Q_1 = k_v \sqrt{\frac{\Delta p_1}{1}} = k_v \sqrt{\Delta p_1}$$



The indices 1 can now be eliminated and are omitted. $Q = k_v \sqrt{\Delta p}$ is transcribed once more, and the final formula for k_v emerges.

$$k_v = \frac{Q}{\sqrt{\Delta p}} \text{ m}^3 / \text{h}$$

For practical reasons we are presenting the formula in three different versions

$$k_v = \frac{Q}{\sqrt{\Delta p}} \text{ m}^3 / \text{h}$$

$$Q = k_v \sqrt{\Delta p} \text{ m}^3 / \text{h}$$

$$\Delta p = \left(\frac{Q}{k_v} \right)^2 \text{ Bar}$$

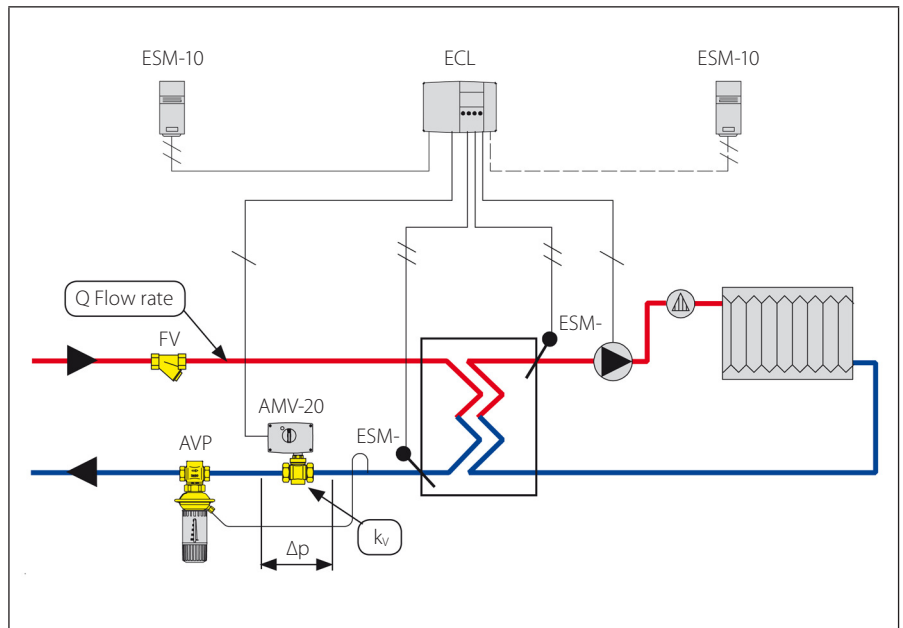

FIGURE 1

By using one of these three formulae, we can always easily determine one value when we know the other two. It is often of importance to be able to convert from k_v into C_v US or C_v UK or vice versa.

Conversion factors

$1 k_v = 1 C_v \text{ US} \times 0.86$ and
 $1 C_v \text{ US} = 1 k_v \times 1.17$

$1 k_v = 1 C_v \text{ UK} \times 1.03$ and
 $1 C_v \text{ UK} = 1 k_v \times 0.97$

More articles

- [1] *Valve characteristics for motorized valves in district heating substations*, by Atli Benonysson and Herman Boysen
- [2] *Optimum control of heat exchangers*, by Atli Benonysson and Herman Boysen
- [3] *Auto tuning and motor protection as part of the pre-setting procedure in a heating system*, by Herman Boysen
- [4] *Differential pressure controllers as a tool for optimization of heating systems*, by Herman Boysen
- [5] *District heating house substations and selection of regulating valves*, by Herman Boysen
- [6] *Pilot controlled valve without auxiliary energy for heating and cooling systems*, by Martin Hochmuth
- [7] *Pressure oscillation in district heating installation*, by Bjarne Stræde
- [8] *Dynamic simulation of DH House Stations*, by Jan Eric Thorsen

More information

Find more information on Danfoss District Energy products and applications on our homepage: www.heating.danfoss.com

**Danfoss A/S**

DK-6430 Nordborg
Denmark
Tel.: +45 74 88 22 22
Telefax: +45 74 49 09 49
E-mail: danfoss@danfoss.com

Danfoss can accept no responsibility for possible errors in catalogues, brochures and other printed material. Danfoss reserves the right to alter its products without notice. This also applies to products already on order provided that such alterations can be made without subsequential changes being necessary in specifications already agreed. All trademarks in this material are property of the respective companies. Danfoss and the Danfoss logotype are trademarks of Danfoss A/S. All rights reserved.