

ENGINEERING  
TOMORROW

*Danfoss*

Application guide

# Reduce energy costs and optimize your installation

10 recommended AB-QT applications

**2 years**

payback time  
when you upgrade  
your one-pipe  
heating system with  
our AB-QT solution.



[www.hbc.danfoss.com](http://www.hbc.danfoss.com)

---

# Index

- 1. Introduction 3
  
- 2.1. One-pipe system control – vertical 4
- 2.2. Two-pipe system control – inconsequential risers only 6
- 2.3. One-pipe system control – horizontal 8
- 2.4. Floor heating flow temperature control (self acting) 10
- 2.5. Air curtain control 12
- 2.6. Ensure low temperatures in the heating supply line 14
- 2.7. Domestic hot water storage tank temperature control 16
- 2.8. Condensing boiler – return temperature control 18
- 2.9. Boiler protection 20
- 2.10. Balancing and return temperature limitation in surface heating 22
  
- 3. Sizing and setting of AB-QT 24
  
- 4. Reference project 26
  
- 5. Glossary and abbreviations 28
  
- 6. Product overview 29
  - 6.1. AB-QT 29
  - 6.2. Order numbers 29
  
- 7. Tender text 30

---

# 1. Introduction – AB-QT solution

## Our innovation

Danfoss has combined its well known **AB-QM** Pressure Independent Balancing & Control Valve with a **QT** thermostatic temperature controller. These two products together are referred to as the **AB-QT** solution. AB-QT controls the flow in a water based installation depending on the return or flow temperature in the system.

## Success story

Danfoss has initially successfully applied this AB-QT solution in renovation stage of one-pipe heating systems, where residents complained about under- or overheated rooms caused by poor hydronic balance. Instead of having to replace the complete one-pipe system in the entire building to a new and expensive two-pipe system, building owners can now choose for the easy-to-implement Danfoss AB-QT solution. AB-QT will make a one-pipe heating system more energy efficient.

Without having to involve all residents of the building, the one-pipe heating system can be equipped with AB-QM and QT elements in the risers of the heating system. The AB-QM will continuously balance the flow in the system and as soon as the temperature in the riser becomes higher than the set temperature, the QT thermostatic controller closes the balancing valve. The flow reductions lower the return flow temperature and prevent overheating and it will make the installation more energy efficient. Because of the relatively low (installation) costs of this solution in this particular case, the return on investment is very high and five times cheaper than renovation to a two-pipe system.

## The AB-QT solution:

- reduces overheating in the building/system
- reduces heating costs
- improves temperature control

## Optimized return flow temperature

The optimum application of the AB-QT solution is the electronic version (AB-QTE). This electronic solution allows for automatic control of the return temperature independent of the supply temperature, and based on the outside temperature. A thermal actuator is used to control the return flow temperature sensors on each riser and an outdoor temperature sensor. This provides an optimized return flow temperature and results in additional energy savings during all seasons of the year.

## The AB-QTE solution:

- provides full control, based on the outside temperature
- provides easy monitoring\* of each riser (settings, temperature, etc.)

\* For more information about AB-QTE, please contact your local Danfoss representative or find information on our website.

## Various applications

Other than using the AB-QT solution in a one-pipe heating system, it can also be applied in many other water based systems. Danfoss has made this AB-QT application guide to show you how to apply this solution in different situations. We give you a description of the application, we advice you about the designing and sizing and we give you an indication of the investment and operational costs.

## Conclusion

AB-QT is a self acting genius in hydronic balancing & control and saves a significant amount of energy.

For more information about AB-QT and some reference cases, please visit: [www.hbc.danfoss.com](http://www.hbc.danfoss.com)



## 2.1 One-pipe system control – vertical

When the rooms in the building have reached their set temperatures the radiator thermostats start to close. In a one-pipe system that means that the heating water will bypass the radiator without a chance to release the energy to the room and therefore the return temperature in the system will increase substantially. The high return temperature will cause several problems, like small  $\Delta T$  in the system and return pipes overheating

the rooms. In general a waste of energy will be the result. To solve these problems Danfoss recommends the use of the AB-QT solution. With this solution an AB-QM pressure independent valve is placed in the return to balance the system and a QT self acting thermostatic actuator will limit the return temperature by reducing the flow if the return temperature rises above the setpoint (see schematic).

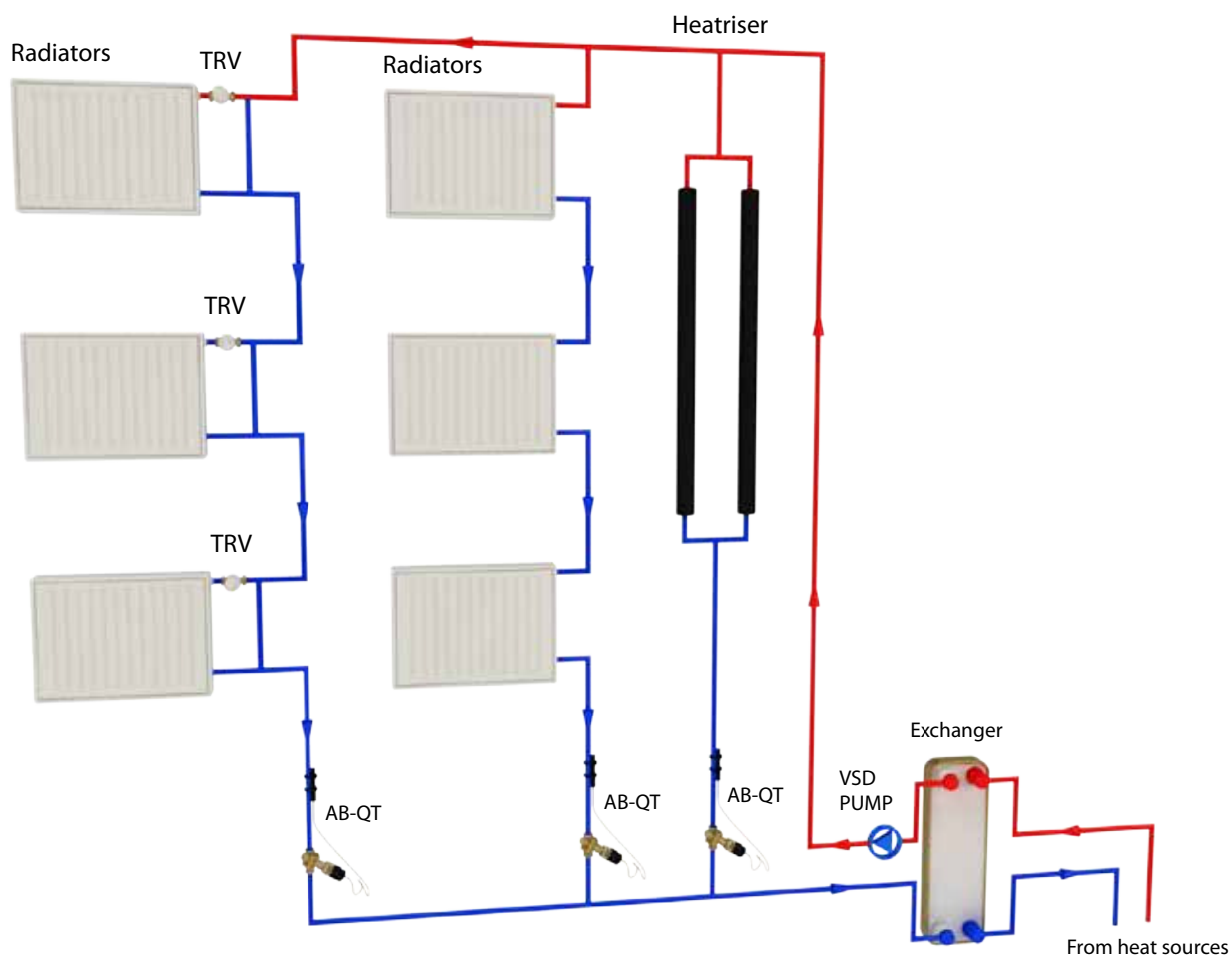

TRV – Thermostatic radiator valve  
AB-QT – Pressure independent balancing valve with thermostatic sensor  
VSD – Variable speed drive

---

## 1 Design / Sizing

- The setting of the AB-QM<sup>A</sup>) is based on calculated flow rate according heat demand of the riser and expected temperature drop on the risers. With this proper hydronic balance is ensured in the system and it avoids over- and underflows.
- The setting of the QT<sup>T</sup>) element depends on several factors\* (two temperature ranges are available).  
For example:
  - Renovation effectiveness – how oversized is the system
  - Internal heat gain (room type) – how big is the expected internal gain (energy emitted by people, lighting or electric equipment) compared to the heat loss.
- for more detailed information please check the AB-QT data sheet or contact your local Danfoss representative

## 2 Investment / Operational cost

- Investment costs<sup>B</sup>) – MEDIUM, compared to the widely used manual balancing. On the other hand no commissioning<sup>C</sup>) is needed for AB-QT so there are no commissioning costs.
- If the AB-QM is already installed the investment costs are very low because only the additional QT element is needed to realise substantial savings.
- Speed control on the pump with a VSD<sup>D</sup>) ensures a costs reduction by lowering the energy needed for circulation of the water.
- High energy saving<sup>E</sup>), especially with low outdoor temperature due to optimization of the partial load condition.
- Expected pay back time 1-3 years.

## 3 Other

- Balancing at full and partial load – VERY GOOD
- Reduces a lot of other problems (like back flow, recommissioning demand, etc.) surrounding traditional one pipe systems.



# 2.2

## Two-pipe system control – inconsequential risers only

In most two-pipe systems there are inconsequential risers like in staircases, internal bathrooms etc., where no thermostatic radiator valves are used or the heat demand does not increase with lower outdoor temperatures. In that case there is the possibility to reduce the heat load of the riser (and save energy) if you limit the flow based on the return temperature.

The simplest solution is to use the Danfoss AB-QT solution. In this way it is possible to limit the maximum flow through one riser (with AB-QM) and reduce it (by QT self acting controller) when the return temperature is increasing because the outdoor temperature rises.

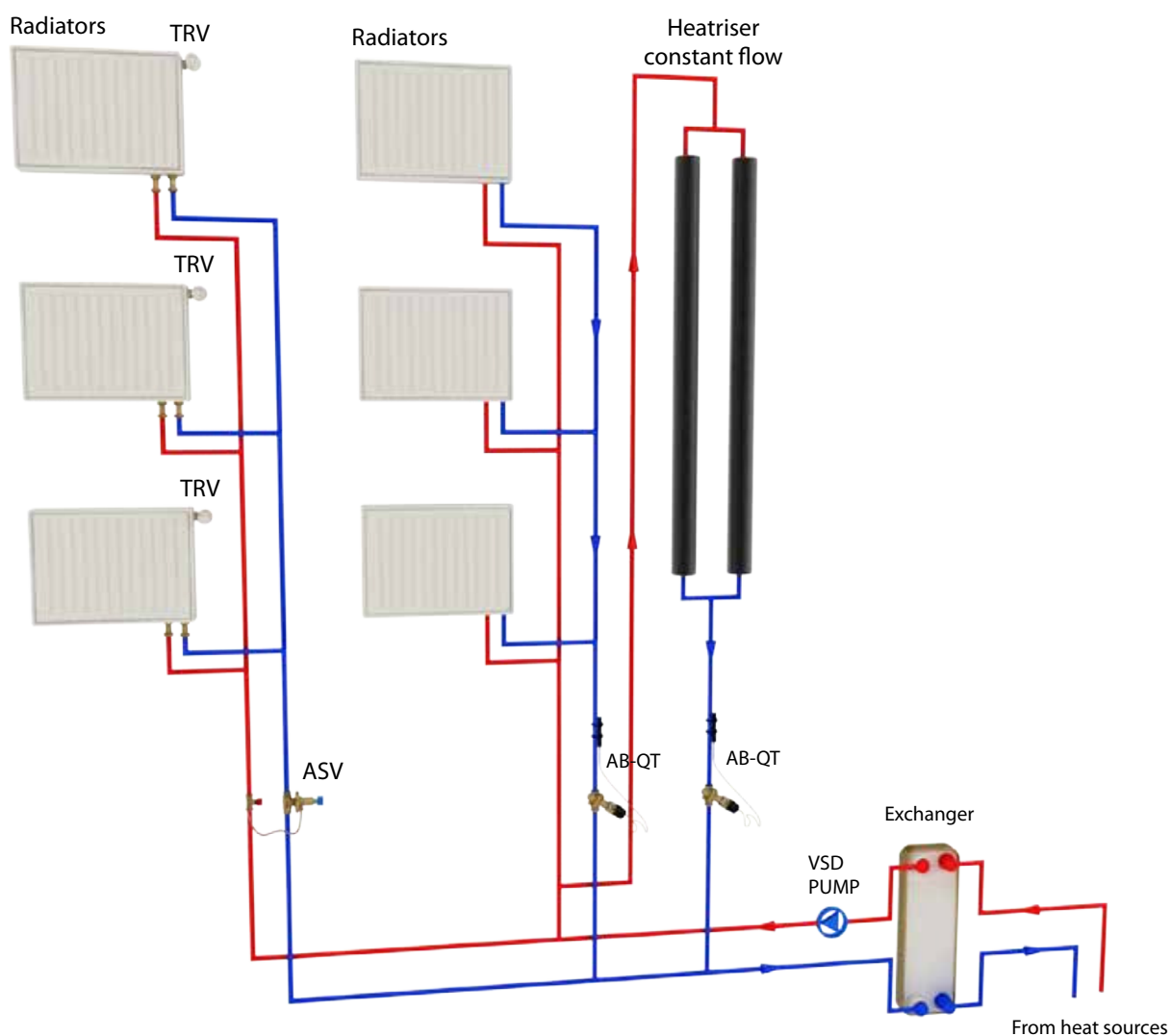

- AB-QT:- Pressure independent balancing valve with thermostatic sensor
- TRV – Thermostatic radiator valve
- ASV – Automatic balancing pressure controller
- VSD – Variable speed drive

## 1 Design / Sizing

- The setting of AB-QM<sup>A)</sup> is based on the calculated flow rate according to the heat demand of the riser and the expected temperature drop in the system. When the QT element is closing it ensures a bigger  $\Delta T^G$  on the riser by reducing the flow
- The setting of the QT<sup>J)</sup> element depends on the over sizing of the riser, the real room temperature demand and internal heat gains. It is recommended to set the sensor according to operational experiences.

## 2 Investment / Operational cost

- Investment costs<sup>B)</sup> – MEDIUM, compared to the widely used manual balancing valves or SIMILAR compared to automatic  $\Delta p$  riser control. No commissioning<sup>C)</sup> is needed for AB-QT, unlike for manual balancing valves.
- The use of a speed controlled pump by way of a VSD<sup>D)</sup> is strongly recommended (due to the variable flows in the system).
- High energy saving<sup>E)</sup> especially with low outdoor temperatures due to the increasing flow temperature.
- Expected payback time 1-3 years (depends on the original installation).

## 3 Other

- Balancing at full and partial load – VERY GOOD
- With the flow limitation on AB-QM it prevents the riser from overflow.
- It is highly recommended to use a  $\Delta p$  controller (ASV-P/PV) on risers with thermostatic radiator valves (TRVs). (Plain manual balancing is not correct in a variable flow system!) For more details, see Danfoss HVAC application guide.



## 2.3 One-pipe system control – horizontal

The horizontal one-pipe solution is becoming less and less popular despite its many advantages. The reason is that these systems are not energy efficient. In partial load the return temperature is increasing because the thermostatic radiator valves are closing and water is directly bypassed to the return. The heat losses on the pipeline increase and it is a nearly constant flow system with high pump

energy consumption, system  $\Delta T$  is small. Danfoss recommends the use of the AB-QT solution. In this way it is possible to limit the flow (with AB-QM) and reduce the flow rate (by QT element) when the return temperature increases.

The recommended QT setting depends on system parameters.

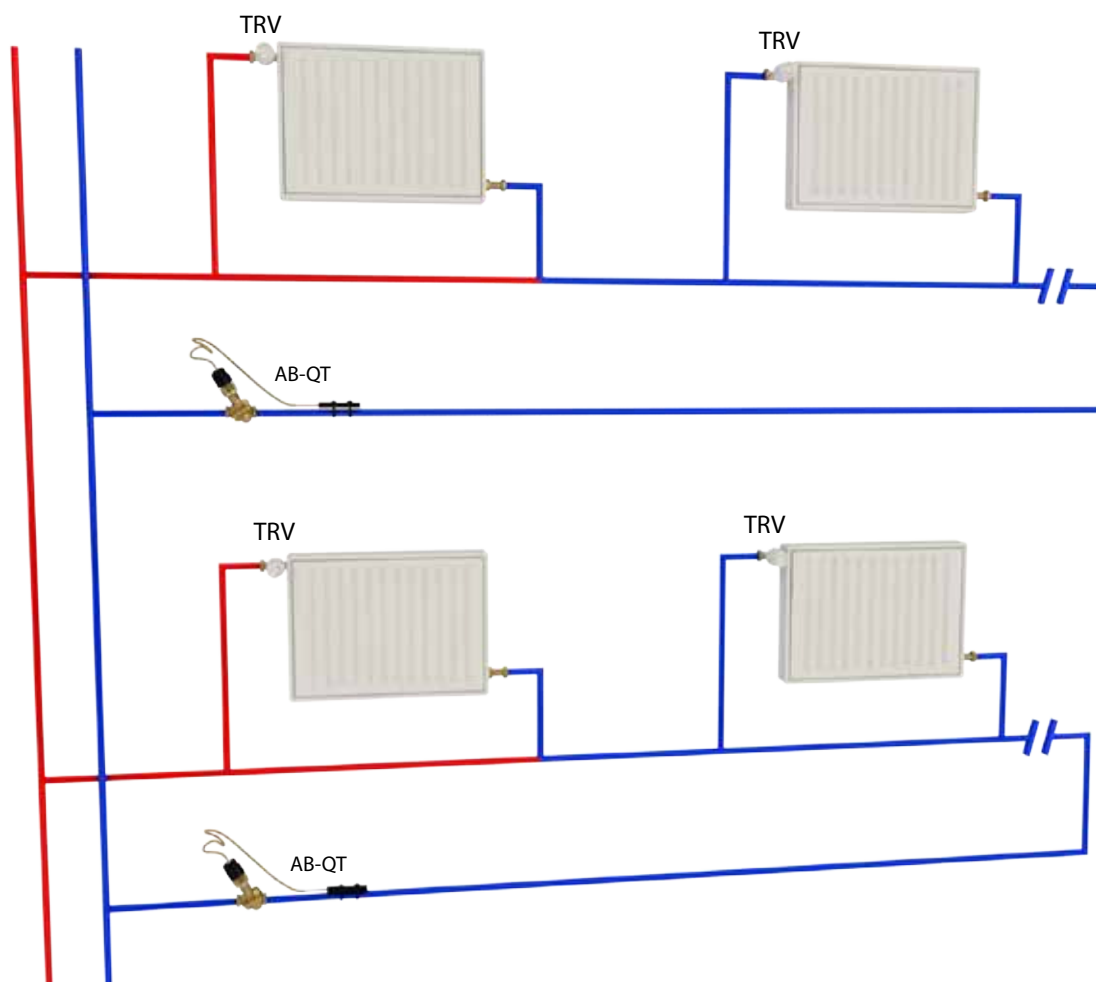

TRV – Thermostatic radiator valve

AB-QT – Pressure independent balancing valve with thermostatic sensor



## 1 Design / Sizing

- The setting of the AB-QM<sup>A)</sup> is based on calculated flow rate according heat demand of the loop and expected temperature drop on it. With this proper hydronic balance is ensured in the system and it avoids over- and underflows.
- The setting of the QT<sup>J)</sup> element depends on several factors (two temperature ranges are available).  
For example: – Renovation effectiveness – how oversized is the system; – Internal heat gain (room type) – how big is the expected internal gain (energy emitted by people, lighting or electric equipment) compared to the heat loss.
- for more detailed information please check the data sheet or contact your local Danfoss representative

## 2 Investment / Operational cost

- Investment costs<sup>B)</sup> – MEDIUM, compared to widely used manual balancing. On the other hand no commissioning<sup>C)</sup> is needed for AB-QT so there are no commissioning costs.
- If the AB-QM is already installed the investment costs is low because only the additional QT element is needed to realise substantial savings.
- Speed control on the pump with a VSD<sup>D)</sup> ensures pumping costs reduction by lowering the energy needed for circulation of the water.
- High energy saving<sup>E)</sup>, especially with low outdoor temperature due to optimization of the partial load condition.
- Expected pay back time 1-3 years.

## 3 Other

- Balancing at full and partial load – VERY GOOD
- The use of thermostatic radiator valves is highly recommended.



## 2.4

# Floor heating flow temperature control (self acting)

Very often convection (radiators) and radiation (floor heating) are combined. In such systems a lower floor heating supply temperature is needed than for radiators. This means a mixing loop to reduce the supply temperature to the required level needs to be created. (The most common connection can be seen in the drawing).

Danfoss recommends the use of the AB-QT solution. In this way it is possible to balance the system, limit the flow rate (with AB-QM) on the primary side and set the flow temperature (by QT element) in the floor heating loop. (This application presumes a primary pump as well).

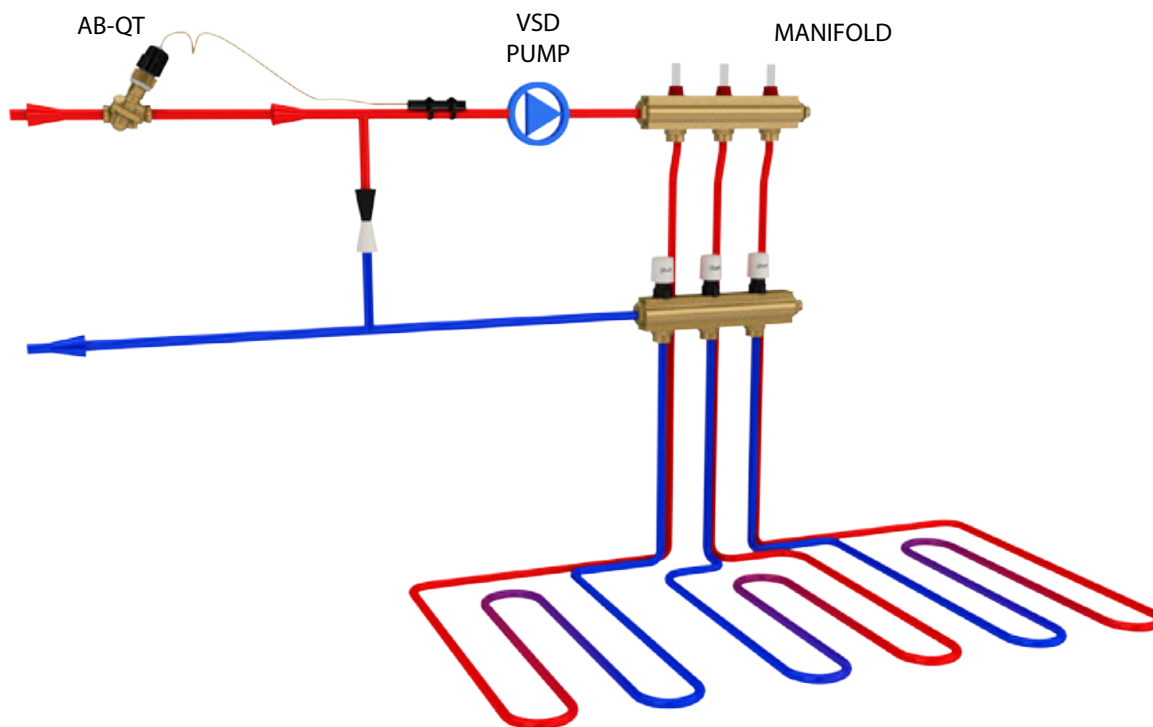

AB-QT – Pressure independent balancing valve with thermostatic sensor  
VSD – Variable speed drive

## 1 Design / Sizing

- The setting of the AB-QM<sup>A)</sup> is based on the calculated flow rate needed for the floor heating and the expected temperature drop on the primary side (Note: The  $\Delta T$  in the floor heating loop is much smaller than in the primary side!)
- For flow calculation, take the transition period<sup>H)</sup> into consideration when the flow temperature from the boiler is smaller than the nominal value (the return temperature from the floor is nearly constant). Try to find the working condition with the smallest primary  $\Delta T$ .
- With the AB-QM flow limitation for floor heating is ensured and it avoids overflow, independently from the – continuously changing – available pressure<sup>I)</sup> based on variable flow in the system.
- The QT setting<sup>J)</sup> depends on the designed maximum flow temperature in the floor heating circuit and Xp band<sup>L)</sup>.
- Differential pressure demand of the AB-QM<sup>K)</sup> DN 10-20 is 16 kPa, so it ensures a similar pressure drop as a TRV + radiator + pipeline combined.
- (This application is suitable if a constant floor heating flow temperature is expected.)

## 2 Investment / Operational cost

- Investment costs<sup>B)</sup> – MEDIUM, compared to a self acting control valve and MBV but no commissioning<sup>C)</sup> is needed. SMALLER, compared to a floor heating manifold controlled by a differential pressure and temperature controller.
- Energy saving<sup>E)</sup> on the pump because of lower flows (no overflows) thanks to the AB-QT and accurate and fast control by the QT element.
- Long life time of AB-QT – The reaction of the sensor is based solely on temperature changes, independent from pressure oscillations.

## 3 Other

- Balancing at full and partial load – EXCELLENT
- Individual temperature control on the floor heating loops is highly recommended (please ask your local Danfoss representative).
- The QT setting can be changed by user depending on the required floor surface temperature and/or heat demand.
- An AVDO pressure relieve valve is needed if the floor heating pump is not speed-controlled by VSD<sup>D)</sup>.



## 2.5 Air curtain control

Air curtains are used to separate 2 temperature zones, usually at building entrances. Because these curtains are usually located far from other parts of the heating system it is rather difficult and expensive to equip them with a control signal from the BMS. It is therefore practical to use a self acting controller in such an application (generally it is not common to use electrical heating because of operational costs).

Danfoss recommends the use of the AB-QT solution. The AB-QM will limit the flow rate of water through the air curtain and the water temperature can be set by using the QT element. This application does not require an exact air temperature so a relatively stable temperature is good enough. Therefore you can set it on the QT element based on the return temperature in the pipeline.

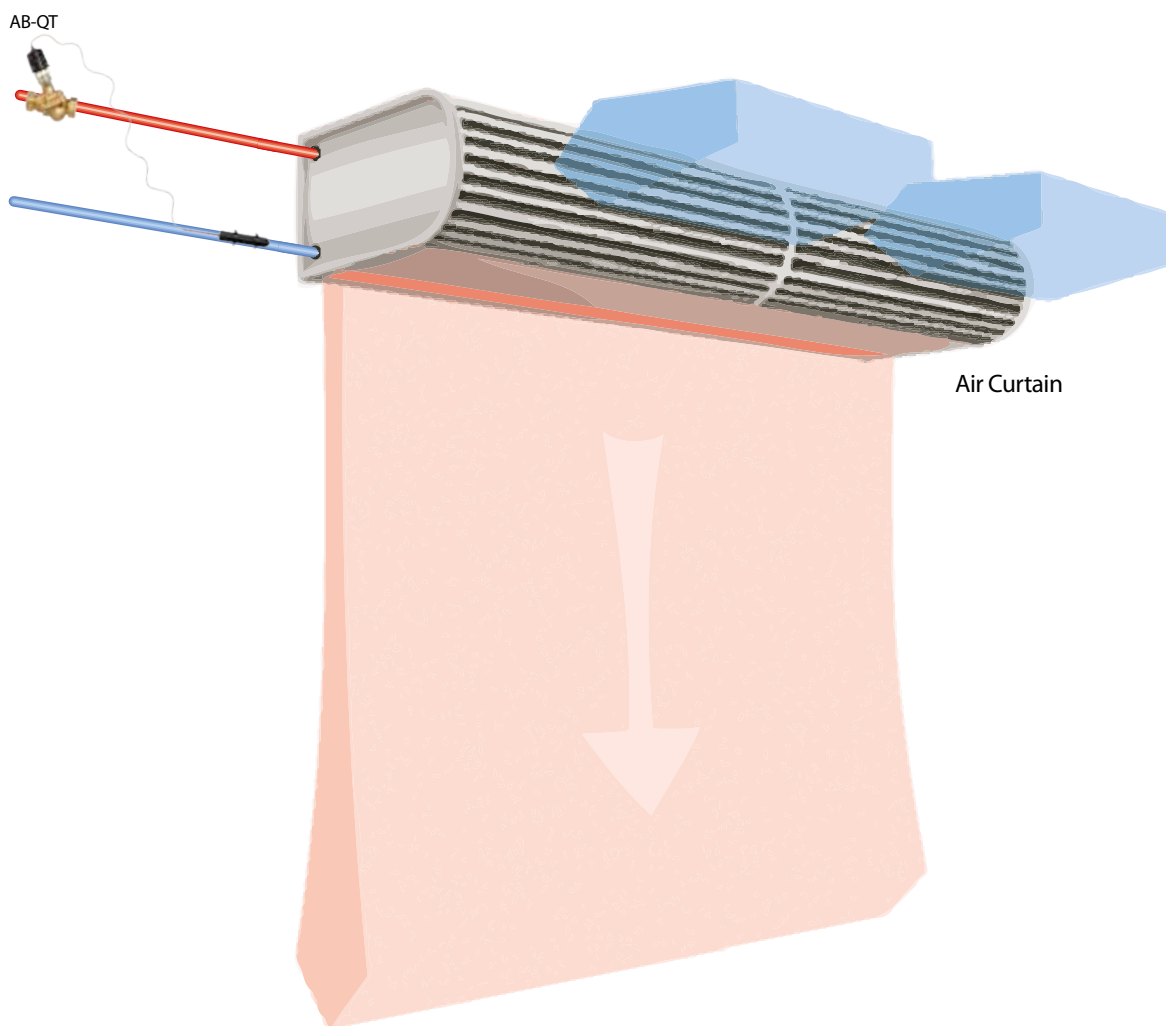

AB-QT – Pressure independent balancing valve with thermostatic sensor

## 1 Design / Sizing

- During the sizing of the air curtain many factors should be taken into consideration, like application, size of the inlet, temperature differences (inside-outside), air flow rate and the needed air temperature.
- The last two factors, combined with the expected supply temperature from the boiler and the required  $\Delta T$  on the coil, are needed to calculate the heating capacity, which determines the setting of the AB-QM<sup>A)</sup>.
- With the AB-QM precise flow limitation is ensured and it avoids overflow through the air curtains, independently from the – continuously changing – available pressure<sup>B)</sup>.
- The QT setting<sup>C)</sup> should be based on the required air temperature and Xp band<sup>D)</sup>.
- The differential pressure demand for the AB-QM<sup>K)</sup> DN 10-20 is 16 kPa – similar to the  $\Delta p$  demand of other control elements, no special consideration is needed.

## 2 Investment / Operational cost

- Investment costs<sup>B)</sup> – LOW, compared to commonly used electronic motorised control valve + controller.
- The AB-QM ensures pressure independent flow control thus no commissioning<sup>C)</sup> is needed.
- Energy saving<sup>E)</sup> – no overheating in the air curtain coil, the circulated flow rate is kept on minimum level, resulting in a big  $\Delta T$ <sup>G)</sup> over the system. Control by the QT element is accurate and fast.
- Lower operational costs of water based air curtains compared to electrically heated versions.

## 3 Other

- Balancing at full and partial load – EXCELLENT
- It is recommended to equip all other terminal units in the system with PIBCV or AB-QM to utilize the maximum energy saving potential in variable flow systems.
- The QT setting<sup>J)</sup> can easily be changed (by maintenance staff) based on operational experience.



## 2.6 Ensure high temperatures in the heating supply line

In big systems with long distribution pipelines it is sometimes necessary to ensure that long periods of inactivity, for example night setback, will not cause long waiting times for heating up the water. Especially in air handling units that uses fresh air it can lead to freezing of the coil. In such case a circulation in the pipeline has to be ensured, even when the control valve is closed. Otherwise the supply line will cool down and it will take too long for heated water to reach the coil.

Danfoss recommends the use of the AB-QT solution. The QT element will control the temperature and will prevent the temperatures to become too low. The AB-QM limits the flow, independent of the available pressure.

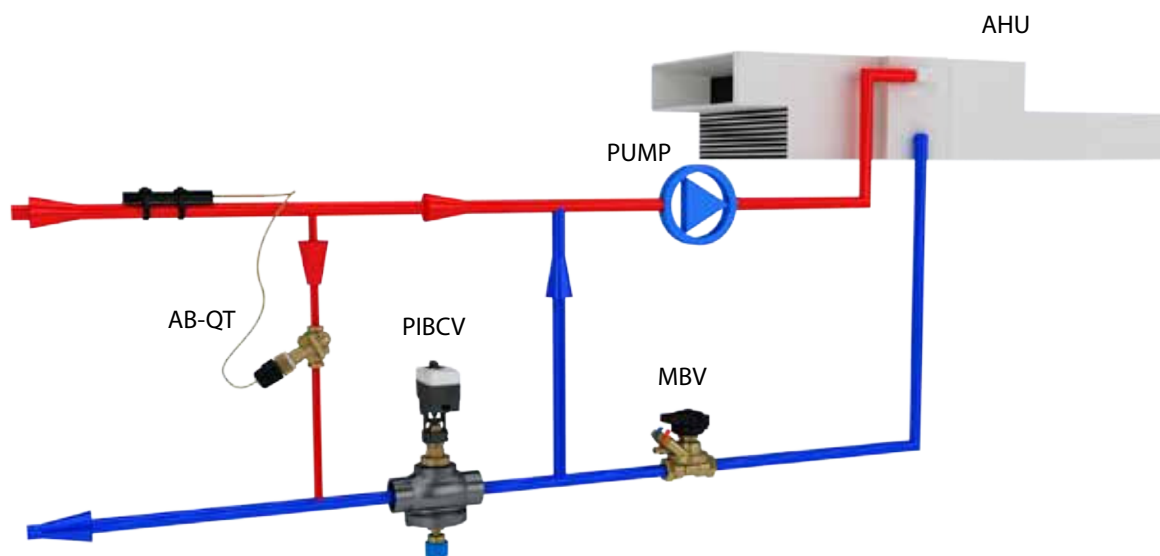

AB-QT – Pressure independent balancing valve with thermostatic sensor  
PIBCV – Pressure independent balancing & control valve  
MBV – Manual balancing valve  
AHU – Air Handling Unit

## 1 Design / Sizing

- To correctly size the by-pass valve the cooling of the pipeline has to be calculated. This can be done by taking the length of pipe, the thickness of the insulation, the material of the pipeline, the ambient temperature and the required minimum pipe temperature.
- After calculation of the maximum flow rate you can simply choose the suitable AB-QM valve and set the appropriate flow rate. With the AB-QM flow limitation is ensured and it avoids overflow through the by-pass, independent from the continuously changing available pressure<sup>l)</sup>.
- The setting of the QT<sup>j)</sup> element has to fit the min. required pipe temperature, taking into consideration the Xp band<sup>l)</sup> of the self acting sensor (QT) in combination with the presetting of the AB-QM.
- General recommendation: The setting of the QT should not be lower than 5°C below the minimum flow temperature during the season.

## 2 Investment / Operational cost

- Investment costs<sup>b)</sup> – MEDIUM compared to the commonly used thermostatic valves which are not pressure independent but HIGH compared to a fixed by-pass without any control.
- It is the most energy efficient solution because there is no overflow, we keep the  $\Delta T^g)$  in the system as big as possible and the self acting control ensures low operational costs, because it needs no electricity.
- The AB-QM ensures pressure independent flow control with simple presetting, so no commissioning<sup>c)</sup> is needed.

## 3 Other

- Balancing at full and partial load – EXCELLENT
- The temperature sensor has to be outside of the insulation to ensure the right control.
- The QT setting<sup>j)</sup> can easily be changed (by maintenance staff) based on operational experience.
- When the AHU is in operation and the flow temperature is higher than the set value on the QT element, the by-pass is fully closed.



## 2.7

# Domestic hot water storage tank temperature control

In situations where the demand for domestic hot water (DHW) can fluctuate significantly it is good practice to use a storage tank for the hot water. This will ensure that there is always sufficient DHW available, even if there is a sudden high demand.

For hot water tank control Danfoss recommends the AB-QT solution. The AB-QM limits the charging flow through the heat exchanger of the tank, independent of pressure oscillations in the heating system and with the QT element we can accurately set the required DHW temperature.

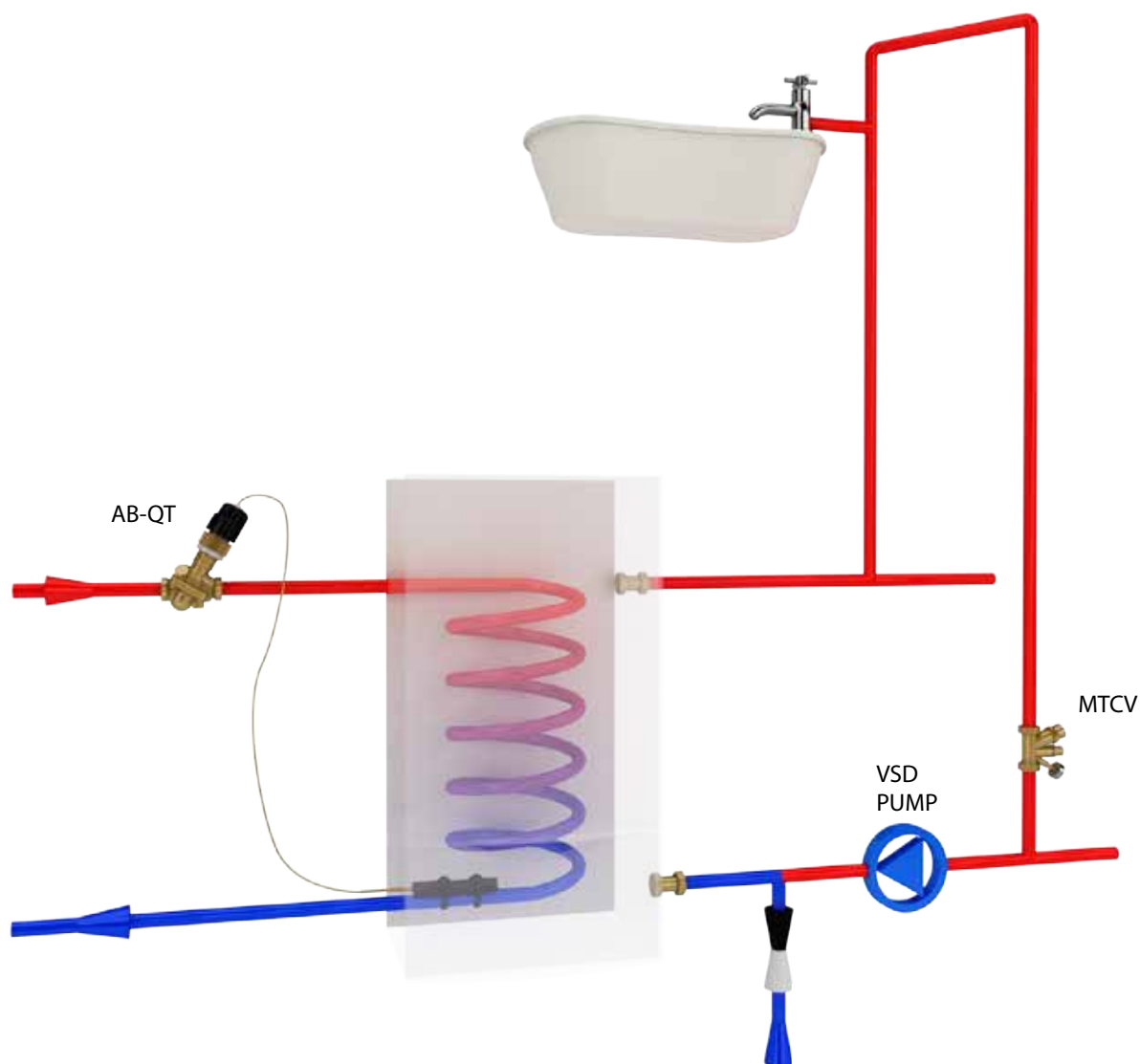

AB-QT – Pressure independent balancing valve with thermostatic sensor  
VSD – Variable Speed Drive  
MTCV – Multifunctional thermostatic circulation valve



## 1 Design / Sizing

- The AB-QM setting<sup>A)</sup> should be done according to the calculated tank charging flow rate. It can be calculated from the size of the tank, which is determined by the expected DHW usage, the “regenerate” time and the attainable  $\Delta T$  on the heating side. During the  $\Delta T$  calculation, take the cold water temperature and the required tap temperature as well as the heating temperature in summer time into consideration. This is the worst situation with the heating flow temperature at the lowest.
- With the AB-QM flow limitation for the tank heating circuit is ensured and it avoids overflow, independent of the varying available pressure<sup>B)</sup> during the winter period (effected by the other part of heating system).
- The QT setting<sup>C)</sup> depends on the desired tap temperature and the Xp band<sup>D)</sup> of the control.

## 2 Investment / Operational cost

- Investment costs<sup>B)</sup> – MEDIUM, compared to the most common solution of an on/off valve controlled by a thermostat, complete with manual balancing valve.
- Lower pump energy consumption because this avoids overflow. The self acting control simplifies the system and ensures low operational costs based on optimised (maximised)  $\Delta T$  in DHW preparation.
- The AB-QM ensures pressure independent flow control with a simple presetting. So, no need for commissioning<sup>E)</sup>.

## 3 Other

- Balancing at full and partial load – VERY GOOD
- Usually DHW production gets priority over the heating of the building. The two processes can run in parallel but it is dependent on the capacity of the boiler. This decision needs to be taken during the design process and the calculations should be done accordingly.
- It is highly recommended to use a return temperature limiter (MTCV) in the circulation pipeline to improve the efficiency and to prevent Legionella growth.



## 2.8 Condensing boiler – return temperature control

The use of a condensing boiler has become more popular but it remains a challenge to obtain the necessary low return temperature to ensure optimal condensation, which results in high(er) boiler efficiency. Very often – especially in radiator applications in case of lack of balancing, etc. – the return temperature is too high (more than 45-50°C), so there is no or very limited condensation. This way the end-user will not benefit from energy savings.

The simplest way to ensure an optimal condensation process is to limit the return temperature. Danfoss recommends to use the AB-PM+QT solution. The AB-PM valve is able to keep a constant pressure difference and set the needed flow rate in the heating system. By using an QT element the return flow temperature towards the boiler is limited, ensuring the lowest possible temperature necessary for the condensation process.

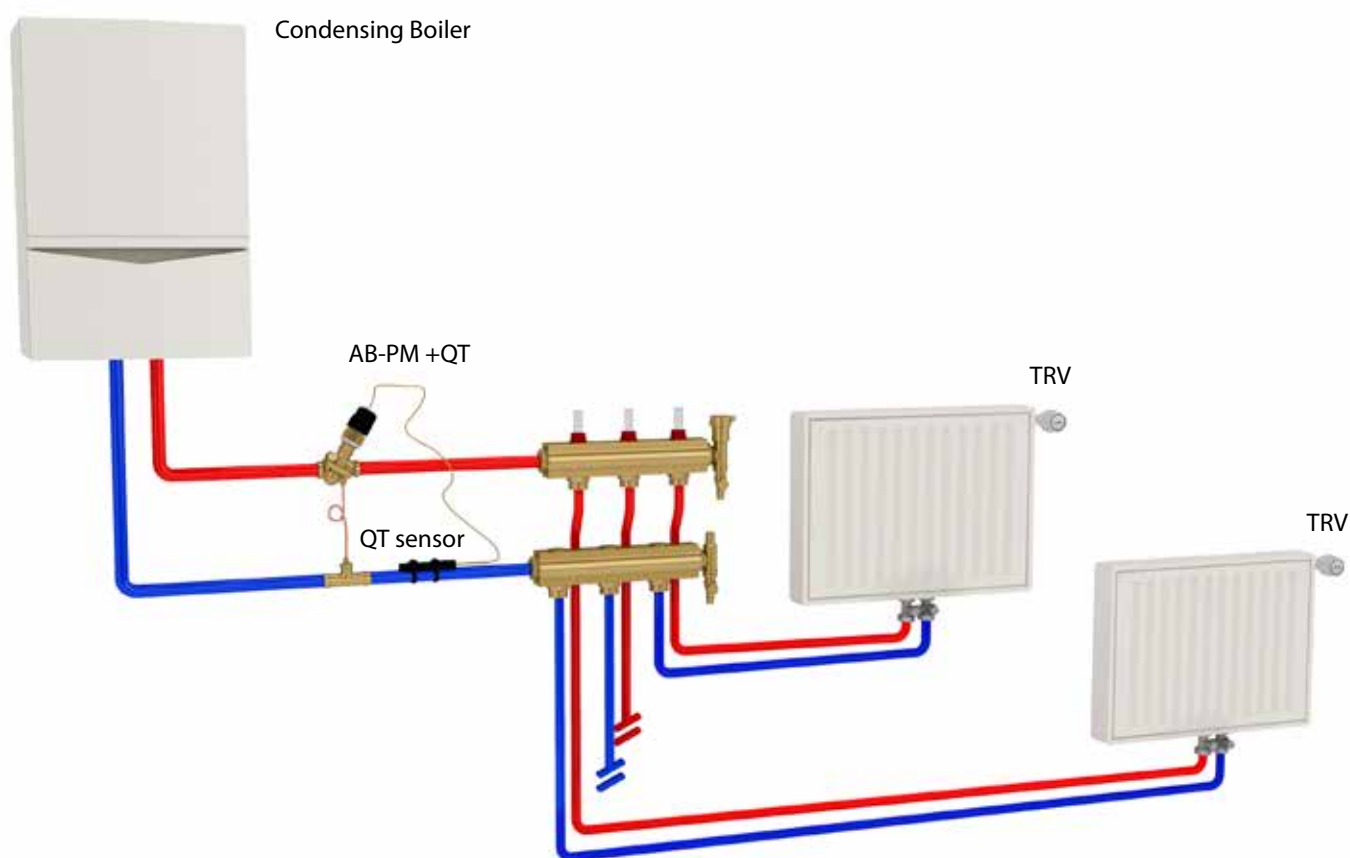

- QT sensor – Thermostatic Sensor
- AB-PM + QT – Self acting thermostatic controller, connected to a pressure independent balancing valve
- TRV – Thermostatic radiator valve

## 1 Design / Sizing

- The AB-PM keeps a constant pressure difference on the controlled loop and ensures flow limitation at the same time. It is not possible to set the pressure difference, so the AB-PM compensates this with flow setting.
- The setting of AB-PM is based on the calculated flow rate according to the heat demand with given  $\Delta T$  and pressure loss on standard heating circuits. When floor heating is part of the application also the real return temperature needs to be calculated, because different return temperatures come together. In the case of bigger installations the control will be more precise when using a single control for all manifolds. The pressure demand of AB-PM is 16 kPa (valve range DN 15-25).
- The QT setting depends on required max. return flow temperature to be taken into consideration the Xp band of the self-acting element.

## 2 Investment / Operational cost

- Investment cost – LOW, compared to individual  $\Delta p$  controller and return flow temperature limiter or just compared to money loss on missed energy savings.
- No commissioning demand, set and forget solution.
- Energy saving is substantial due to increased efficiency of the boiler and more precise room temperature control provided by pressure difference control.
- Long life time of AB-PM + QT – fast sensor responds to temperature change, independent from pressure oscillation to ensure further energy saving.

## 3 Other

- Balancing at full and partial load – EXCELLENT
- For condensation boilers it is a good decision to choose such temperature regime that ensures condensation during most of operation time. Never use hydraulic coupling or direct by-pass to return, this destroys the efficiency of the boiler (no condensation).
- Possible for users to change the QT setting according to heat demand based on outdoor temperature.
- VSD is recommended for further energy saving.
- Many other variations are possible for this control principle. For more details please contact local Danfoss sales representative.



## 2.9 Boiler protection

Many types of boilers (like solid fuel and oil burning boilers) must be protected from return temperatures that are too low. Otherwise cracks might appear in the heat exchanger or unwanted condensation could occur. The most critical time frame is when the installation is heating up from a cold situation. For example: After night setback when the water temperature in the system could be around 20°C.

For boiler protection usually the supply water is bypassed back to the return until the desired temperature is reached. This recirculation must be controlled. Danfoss recommends the use of the AB-QT solution. The AB-QM limits the flow through the bypass, independent of the pump head of the circulation pump. The required minimum inlet temperature of the boiler can be set with the QT element.

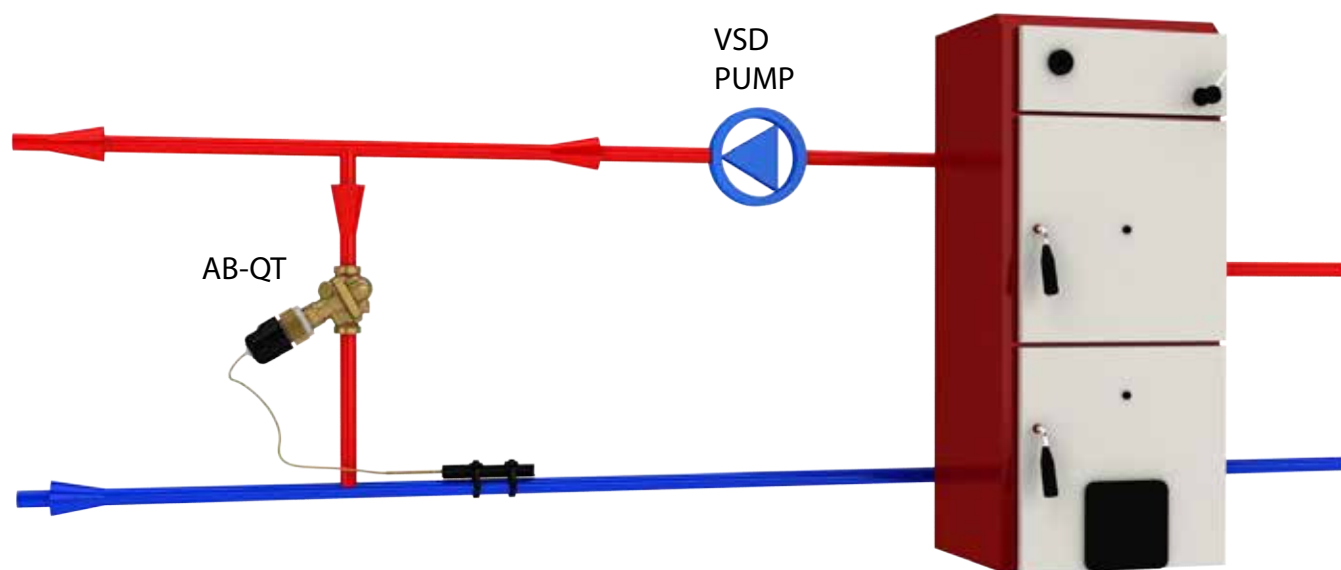

AB-QT – Pressure independent balancing valve with thermostatic sensor  
VSD – Variable Speed Drive (recommended)

## 1 Design / Sizing

- We need to determine the temperature regime of the system and the expected return temperature to the boiler, as specified by the boiler producer. The possible flow temperature and circulation flow rate depends on the system design which correlates to the heating capacity of boiler. Additionally it can be assumed that 20°C is the initial water temperature in the pipe network when heating starts. With this information the needed by-pass flow can be calculated to achieve the needed minimum return temperature into the boiler.
- For sizing of the AB-QM by-pass valve, selection is based on required flow rate and then set accordingly.
- For proper mixing the pressure drop rates between the by-pass and the heating circuit have to be suitable. The needed minimum pressure loss of the by-pass should be according to the minimum required pressure drop on the AB-QM valve (see data sheet). Usually the pressure drop of the short pipeline can be neglected.
- The QT setting<sup>j)</sup> depends on the desired minimum return temperature and the control Xp band<sup>l)</sup> of the QT thermostatic element.

## 2 Investment / Operational cost

- Investment costs<sup>b)</sup> – MEDIUM, compared to other not pressure independent self acting controllers. Not needed to immerse the sensor! LOW compared to often used MCV<sup>m)</sup> with electronic ON/OFF control based on return temperature measurement.
- The AB-QM ensures pressure independent flow control without any overflow (most energy efficient solution) and ensures simple presetting of the calculated maximum flow, no commissioning<sup>c)</sup> needed.

## 3 Other

- Balancing at full and partial load – VERY GOOD
- Stable return temperature so no hunting of the control valve when the return temperature oscillates due to ON/OFF boiler control.
- The reaction of QT element is very fast and accurate and able to close fully against a high pump head.
- This application is not suitable for condensing boilers because the condensation will be reduced and latent heat will not be fully utilized, reducing the efficiency of boiler.



## 2.10

# Balancing and return temperature limitation in surface heating

Surface heating (i.e. wall, floor and ceiling) is becoming more and more popular. The advantage is better thermal comfort and higher energy efficiency because of condensing boilers and a lower room temperature with the same comfort level.

In spite of the reverse return (Tichelman) connection of heating panels we have to ensure proper water distribution among – the individually controlled – circuits and it is

recommended to control (limit) the return temperature to achieve a highest  $\Delta T$  in the system as possible.

Danfoss recommends the use of the AB-QT solution. The AB-QM limits the flow through the panels and ensures the balance in the installation while the QT element limits the return temperature.

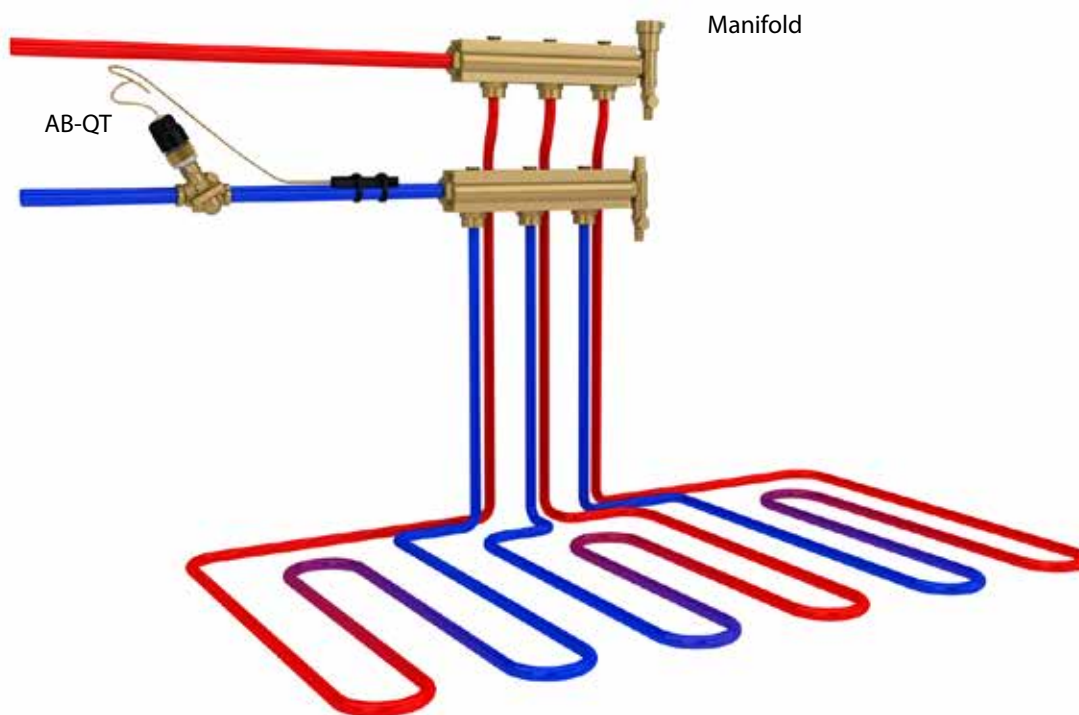

AB-QT – Pressure independent balancing valve with thermostatic sensor

---

## 1 Design / Sizing

- The sizing of AB-QM valve is based on the heat demand and the calculated temperature drop on the surface heating circuit(s). Determining the system (circuit)  $\Delta T$  is crucial because the generally small achievable temperature differences strongly affect the flow rate.
- The AB-QM ensures flow limitation and perfect water distribution among the circuits. It avoids overflow, independent from the load and the available pressure<sup>l)</sup> on the circuits.
- The QT should be set<sup>j)</sup> according to the desired return temperature, taking into consideration the Xp band<sup>l)</sup> of this self acting controller.

## 2 Investment / Operational cost

- Investment costs<sup>b)</sup> – HIGH, compared to the commonly used manual balancing valves (from time to time even no manual balancing is used) without any temperature control, but MEDIUM compared to other zone controller<sup>n)</sup> solutions with manual balancing valves. (Manual balancing is not acceptable in variable flow systems. For more details see our Danfoss HVAC application brochure).
- The AB-QM ensures pressure independent flow control so no commissioning<sup>c)</sup> is needed.
- High energy efficiency is achieved, thanks to an increased  $\Delta T^g)$  in the system which improves the efficiency of boiler and no overflows which lowers the circulation pumps energy consumption. It avoids overheating if the surface temperature is set on the appropriate level and the system becomes self controlled.

## 3 Other

- Balancing at full and partial load – EXCELLENT
- It is recommended to use supplementary heating, like radiator, FC, etc. to follow the rapidly changing heat load/gain.
- This solution with QT sensors is suitable for heating applications only.

### 3 Sizing and setting of AB-QT

QT self acting temperature controller combined with AB-QM pressure independent balancing and control valve ensures linear control characteristic. The valve is closing in case of increasing temperature. The length of the active stroke of the temperature control depends on the presetting of the AB-QM, because the AB-QM presetting limits the length of the stroke. Therefore we have to define the Xp (proportional control) band. You can see the Xp relation between the valve diameter, the presetting and the set temperature on QT element in fig. 1 and fig. 2.

The graphs shows that with the AB-QM DN10 to DN20, with a setting of 50%, the valve will be fully closed when the temperature is 5 K higher than the setting at the QT element. With the sizes DN25 and DN32 the temperature must be 8 K higher before the valve is fully closed.

The setting of AB-QM valve – as flow limiter – is based on calculated flow rate according to the capacity of the controlled terminal unit or the controlled loop/circuit. It is necessary to set the AB-QM before the QT thermostat is mounted.

The QT temperature setting depends on the AB-QM flow setting. It is recommended to select the valve dimension such as to be able to set the AB-QM between 30 and 70 %. Fig. 3 shows the connection between the presetting of the AB-QM and the setting of the QT thermal actuator with different closing temperatures.

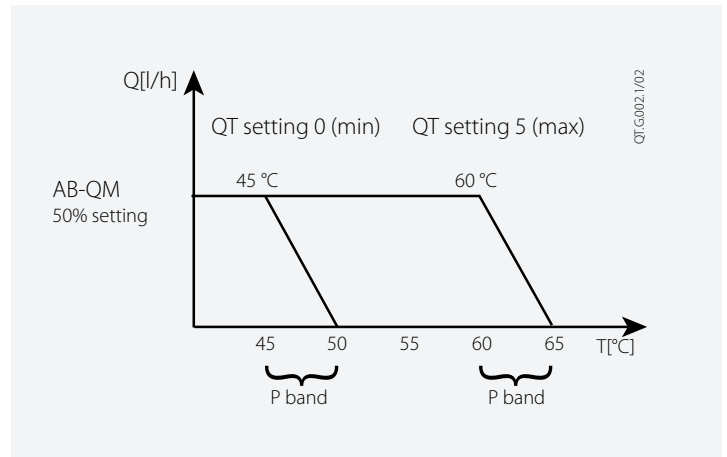

Fig. 1 Xp graph for AB-QT DN 10-20

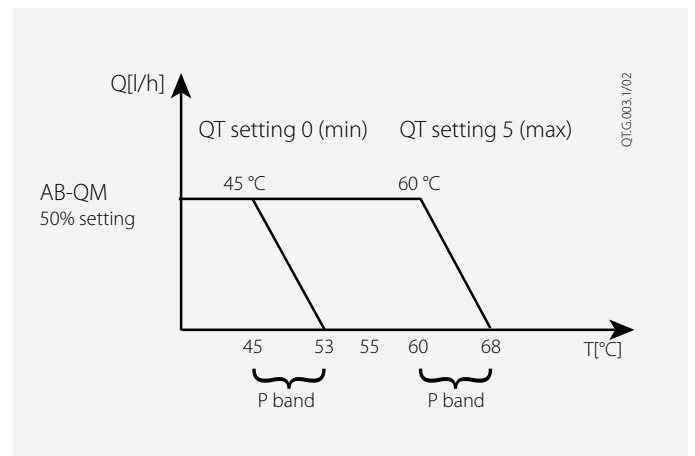

Fig. 2 Xp graph for AB-QT DN 25-32



Temperatura setting		QT Sensor setting (turns)						
		0	1	2	3	4	5	6
AB-QM (flow setting)	Closing 20%	4	4	5	5	5	5	6
	30%	48.0	50.5	53.0	55.5	58.0	60.5	63.0
	40%	47.0	49.5	52.0	54.5	57.0	59.5	62.0
	50%	46.0	48.5	51.0	53.5	56.0	58.5	61.0
	60%	45.0	47.5	50.0	52.5	55.0	57.5	60.0
	70%	44.0	46.5	49.0	51.5	54.0	56.5	59.0
	80%	43.0	45.5	48.0	50.5	53.0	55.5	58.0
	90%	42.0	44.5	47.0	49.5	52.0	54.5	57.0
	100%	41.0	43.5	46.0	48.5	51.0	53.5	56.0

Temperatura setting		QT Sensor setting (turns)						
		0	1	2	3	4	5	6
AB-QM (flow setting)	Closing 20%	4	4	5	5	5	5	6
	30%	49.5	52	54.5	57	59.5	62	64.5
	40%	48.0	50.5	53.0	55.5	58.0	60.5	63.0
	50%	46.5	49.0	51.5	54.0	56.5	59.0	61.5
	60%	45.0	47.5	50.0	52.5	55.0	57.5	60.0
	70%	43.5	46.0	48.5	51.0	53.5	56.0	58.5
	80%	42.0	44.5	47.0	49.5	52.0	54.5	57.0
	90%	40.5	43.0	45.5	48.0	50.5	53.0	55.5
	100%	39.0	41.5	44.0	46.5	49.0	51.5	54.0

Temperatura setting		QT Sensor setting (turns)						
		0	1	2	3	4	5	6
AB-QM (flow setting)	Closing 20%	4	4	5	5	5	5	6
	30%	48.0	40.5	43.0	45.5	48.0	50.5	53.0
	40%	37.0	39.5	42.0	44.5	47.0	49.5	52.0
	50%	36.0	38.5	41.0	43.5	46.0	48.5	51.0
	60%	35.0	37.5	40.0	42.5	45.0	47.5	50.0
	70%	34.0	36.5	39.0	41.5	44.0	46.5	49.0
	80%	33.0	35.5	38.0	40.5	43.0	45.5	48.0
	90%	32.0	34.5	37.0	39.5	42.0	44.5	47.0
	100%	31.0	33.5	36.0	38.5	41.0	43.5	46.0

Temperatura setting		QT Sensor setting (turns)						
		0	1	2	3	4	5	6
AB-QM (flow setting)	Closing 20%	4	4	5	5	5	5	6
	30%	39.5	42	44.5	47	49.5	52	54.5
	40%	38.0	40.5	43.0	45.5	48.0	50.5	53.0
	50%	36.5	39.0	41.5	44.0	46.5	49.0	51.5
	60%	35.0	37.5	40.0	42.5	45.0	47.5	50.0
	70%	33.5	36.0	38.5	41.0	43.5	46.0	48.5
	80%	32.0	34.5	37.0	39.5	42.0	44.5	47.0
	90%	30.5	33.0	35.5	38.0	40.5	43.0	45.5
	100%	29.0	31.5	34.0	36.5	39.0	41.5	44.0

Factory setting: 4

Fig. 3 Setting of the AB-QM and the setting of QT thermal actuator with different closing temperatures

# 4

## Reference project (one-pipe system control – vertical)

### THE PROJECT

The buildings was built in 1976 as a so called “Leningrad Building” consisting of concrete panels. The design and all the building elements were prepared in St. Petersburg in Russia. The heating system design, a traditional one pipe system, originally used a three way valve with a shut-off function only. The radiators are cast-iron types. The heat supply of the building comes from a big sub-station which is located about 100 meters from the building and also supplies two other buildings. Renovation was started in 1994-95 with thermostatic radiator valves installation (Danfoss, RTD-D, type) and sub-station renovation (weather compensator, control valves and  $\Delta p$  controller were installed). Due to lack of money for hydraulic balance was done based on traditional manual method with measuring orifices. In 1996-97 heat cost allocators were installed which allow measuring individual energy consumption. The next step of renovation was done in 2002-2003: wall isolation (10cm of polystyrene) and new windows. Due to still relatively high energy consumption (compared to a traditional two-pipe system) in 2009 the Building Society was considering to change the heating system to a two-pipe system or use automatic, adjustable flow limiters on the risers with self action thermostats (Danfoss solution: AB-QM + QT). Investment for the second solution was five times less expensive!

### USED DANFOSS EQUIPMENT FOR RENOVATION

- A | In 1994-95 : Danfoss radiator thermostat were installed DN 15-20 mm ( 483, 307 pcs. in each building), type RTD-D
- B | in 2009 : Danfoss automatic flow limiters with self action thermostat used in risers: AB-QM with QT  
Dimension: DN 15-20 (57,40 pcs. in each building)

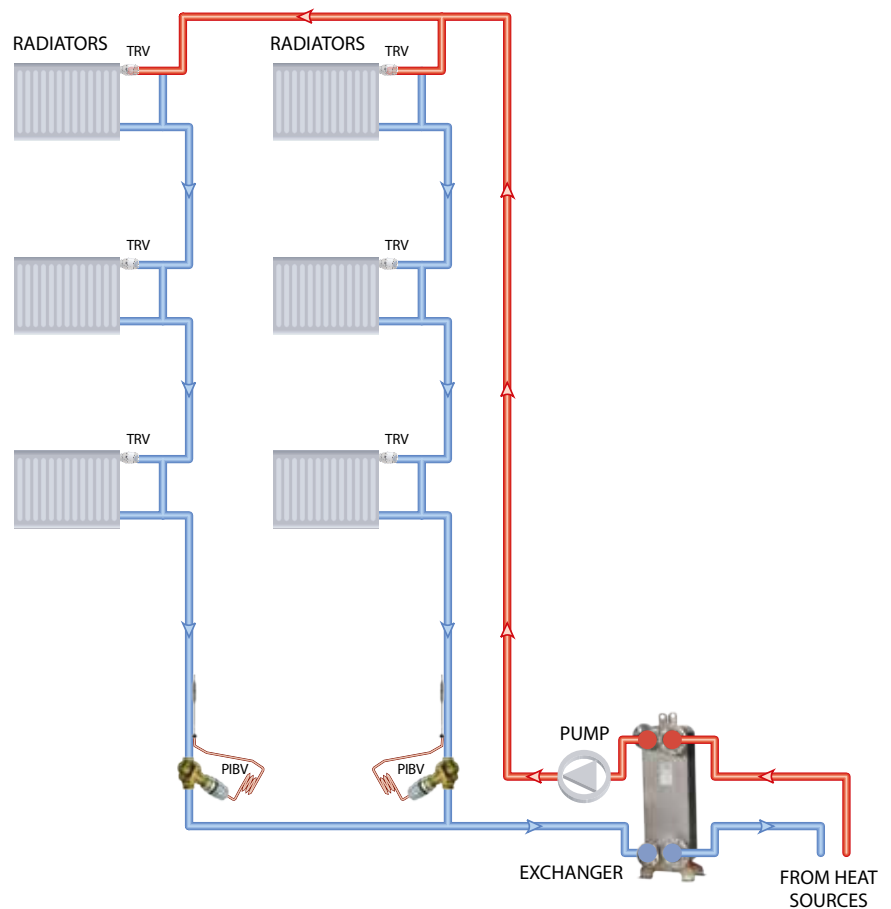

TRV – Thermostatic Radiator Valves  
 PIBV – Pressure Independent Balancing Valves (as flow limiter)  
 QT – Self Acting Thermostat



## SAVINGS

Investment type	AB-QM + QT
Investment costs [€]	32201
Av. energy saving from three heating seasons [GJ]	1283
Energy price (DH) [€/GJ]*	9,7
<b>Pay back time [year]</b>	<b>2,6</b>

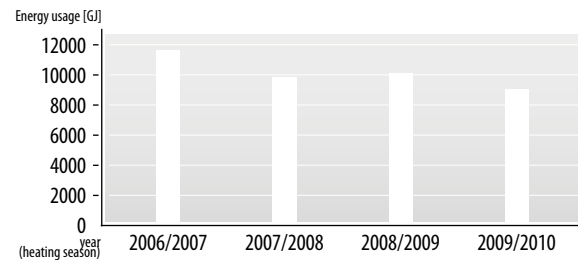

\* as AB-QM and QT were installed in December 2009.

## INVESTMENT COSTS

Equipment	Pcs.	Price [€]	Installation costs [€]	Sum
Automatic flow limiters with self acting thermostat (AB-QM + QT)	291 (91x3)	27063	5238	32201

## ENERGY USAGE AND ENERGY SAVING OF BUILDING

Year (heating season)	Energy used in heating season (GJ)	Corrected energy used (degree-day method) (GJ)	Average outdoor temperature in heating season (°C)	Average energy saving from three heating season in GJ	Action
2006/2007	11355,4	11615,8	6,1		
2007/2008	10403,5	9697,0	3,9		
2008/2009	10795,5	10000,8	3,3		
2009/2010	9876,6	9154,8	2,2	1283	AB-QM + QT installation

## CONCLUSION

This new solution, that controls the flow in the riser depending on the temperature in the pipe, converts a one-pipe system (constant flow system) into a variable flow system. Unnecessary water flow (when TRV's are closed) is reduced to a minimum by self action balancing valves, which were installed in each riser. In spite of AB-QM + QT (thermostat operation) it should be mentioned that AB-QM ensures a proper balance between risers. This is a huge benefit (proved by this case) that due to a correct balance system, there were no complaints about cold risers during a very strong winter period 2009-10!

The proposed solution by Danfoss for one pipe heating system based on automatic flow limiters with self action thermostats (AB-QM + QT) should be recommended for all regions and countries where the energy costs are high as it allows achieving huge energy consumption reductions with high indoor quality comfort! Short pay back time (less than 3 years) which was confirmed by this case is excellent evidence for this proper solution offered by Danfoss.





## 5 Glossary and abbreviations

- A** **Setting of AB-QM:** The flow rate through the AB-QM valves can be set based on a percentage scale. You have to pull up the grey knob of the presetting element and turn it to the right setting. Push the grey knob back down to lock the setting.
- B** **Investment costs:** The amount of money that you have to pay for a certain part of the installation. For the comparison you should take into consideration the whole costs of implementation, including installation and other accessories furthermore commissioning if it is needed.
- C** **Commissioning:** Always calculate the required settings of the manual or automatic balancing valve during the traditional calculation, before you hand the building over to the user. You have to be sure that the flow is according to the required value in all parts of the installation. Due to the fact the system is usually not installed exactly the way it was calculated, you have to check the flow on measuring points and correct deviations if necessary
- D** **Variable Speed Drive (VSD):** Circulation pumps can be equipped with built in or external electronic controllers, ensuring constant, proportional (or parallel), differential pressure on the system by changing the revolutions of the pump.
- E** **Energy saving:** Electrical and /or heat costs reduction based on smaller water circulation in the system, better temperature control and a bigger temperature difference between supply and return flow temperature.
- F** **Back flow phenomenon:** In case of high flow temperatures and big pipe dimensions in one-pipe radiator heating systems, it is possible the radiator heats up despite a closed radiator valve. This happens because there is lower density hot water in the pipeline and relatively high density cold water in the top of radiator. The "heavier" cold water is above the lighter hot water in the return pipeline thus it push the cold water as "float" from the radiator into the bottom part of return pipe while the hot water is streaming into the radiator on the upper part of the same pipe. Finally an artificial two-way flow appears through the return connection pipe of the radiator.
- G** **Bigger  $\Delta T$ :** When the flow through – terminal units like radiators or fan-coils – is limited to the precise amount that is needed, the transfer of energy is optimized. This ensures the lowest return temperature and therefore the biggest differential temperature ( $\Delta T$ ) across the system. A high  $\Delta T$  allows the heating or cooling equipment to run on its highest efficiency.
- H** **Transition period:** Usually in spring or fall when the outdoor temperature is relatively high but heating is already/ still needed.
- I** **Available pressure:** The pressure difference that pushes the water through a valve or heating circuit.
- J** **QT setting:** QT element is a self acting temperature controller. The temperature setting is based on a scale (1-6) in two temperature ranges (35...50°C or 45...60°C). The set temperature refers to an AB-QM presetting 50% with Xp<sup>1)</sup> 5K.
- K** **The differential pressure demand of AB-QM:** The minimum pressure difference needed for the AB-QM to reach the specified flow.
- L** **Xp band:** Proportional control band – Defined as the difference between the temperature or pressure difference between fully open and closed valve position.
- M** **MCV:** Motorised Control Valve – Usually equipped with an actuator for opening and closing the valve.
- N** **Zone controller:** Generally an On/Off controller – The valve is opened or closed according room temperature.

# 6 Product overview

## 6.1 AB-QT: Pressure Independent Balancing Control Valve with self acting temperature controller

Picture	Name	Description	Size (mm)	Flow (m³/h)	Temperature range (°C)	Comments
	AB-QM	Pressure independent balancing control valve, with or without measuring nipple	10... 32	0,27... 3,2		Integrated shut off and draining possibility
	QT	Self acting temperature controller for AB-QM			35...50 45...60	Fast reaction – gas filled thermostat

## 6.2. Order numbers

### PRESSURE INDEPENDENT BALANCING & CONTROL VALVES

Type	Description	Size	Code no. without measuring nipples	Code no. with measuring nipples
AB-QM	Pressure Independent Balancing & Control Valve with max. flow 150 l/h	DN 10 LF	003Z1251	003Z1261
AB-QM	Pressure Independent Balancing & Control Valve with max. flow 275 l/h	DN 10	003Z1201	003Z1211
AB-QM	Pressure Independent Balancing & Control Valve with max. flow 275 l/h	DN 15 LF	003Z1252	003Z1262
AB-QM	Pressure Independent Balancing & Control Valve with max. flow 450 l/h	DN 15	003Z1202	003Z1212
AB-QM	Pressure Independent Balancing & Control Valve with max. flow 900 l/h	DN 20	003Z1203	003Z1213
AB-QM	Pressure Independent Balancing & Control Valve with max. flow 1700 l/h	DN 25	003Z1204	003Z1214
AB-QM	Pressure Independent Balancing & Control Valve with max. flow 3200 l/h	DN 32	003Z1205	003Z1215

### THERMOSTATIC RETURN TEMPERATURE CONTROLLER

Type	Description	Temp. range	Code no.
QT	Thermostatic return temperature controller for combination AB-QM DN 10-20	45 – 60 °C	003Z0382
QT	Thermostatic return temperature controller for combination AB-QM DN 25-32	45 – 60 °C	003Z0383
QT	Thermostatic return temperature controller for combination AB-QM DN 10-20	35 – 50 °C	003Z0384
QT	Thermostatic return temperature controller for combination AB-QM DN 25-32	35 – 50 °C	003Z0385



## 7 Tender text

### AB-QM:

1. The pressure independent balancing and control valve should be comprised of a linear control valve and an integrated membrane based pressure differential controller.
2. The valve could be used as an automatic flow limiter.
3. The valve should have a mechanism to adjust the flow from 100 to 0 % of the maximum flow.
4. Minimum recommended flow setting should not be more than 30 l/h.
5. Shut off service function should be possible with setting mechanism.
6. The adjustment flow setting should be performed without tool up to dimensions DN 32.
7. The leakage rate should be: No visible leakage with manual shut of the valve.
8. The authority of the pressure independent control valve should be 1 at all settings (control valve characteristic is not changed).
9. Minimum starting differential pressure for flow limitation should be 16 kPa for valves up to DN 20, 20 kPa valves up to DN 32. *(Supplier of the valve should provide lab test results<sup>1)</sup>).*
10. Nominal pressure rating 16 bar (PN 20 on request), maximal test pressure 25 bar.

Nominal diameter: \_\_\_\_\_

Connection: \_\_\_\_\_

Adjustment range from – to \_\_\_\_\_ m<sup>3</sup>/h

Produced by: Danfoss

Type: AB-QM

Ordering no.: 003Z\_\_\_\_\_

*1) Since there is no standard for testing procedure, Danfoss recommends verification by independent lab to compare control and flow limitation function of different PIBCVs at the same basis.*

### QT:

1. The thermostatic actuator should ensure linear control characteristic
2. The thermostatic actuator should be available in the setting range for 35...50°C and 45...60°C.
3. The actuator should have a mechanism to steplessly adjust the temperature.
4. Mounting of thermostatic actuator onto the valve body should be performed without tool.
5. The sensor of thermostatic actuator should be able to connect to pipe surface with sensor holder.
6. The sensor package should be complete: thermostatic actuator, sensor holder, fastener, heat conductivity pasta.
7. Proportional control band: 5K with control valve DN 10-20 and 8K with control valve DN 25-32 in case of 50% pre-setting of control valve.
8. Connection thread and spindle distance: fits to Danfoss AB-QM valve.

Adjustment range from – to \_\_\_\_\_ °C

Produced by: Danfoss

Type: QT

Ordering no.: 003Z\_\_\_\_\_



# See you at [www.hbc.danfoss.com](http://www.hbc.danfoss.com)

Danfoss Hydronic Balancing & Control's first point of contact can be found on the internet. At [www.hbc.danfoss.com](http://www.hbc.danfoss.com) or one of the many local websites you can find a complete toolbox of supporting materials. These tools can help you to make the best product selection for each of your projects. Find the best suitable product with the right dimensions and prepare the right setting to make the job on site as easy as possible.

On the website you can find:



#### Literature

Both commercial as technical literature help you to explain our products and solutions to your customers and help you find the best products for your projects.

You can find brochures, case stories, technical datasheets and instruction manuals.

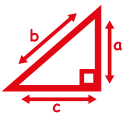

#### Tools

Videos and educational animations help you to understand our products better. Calculation tools and software help you prepare the commissioning on site.



#### Social media

Besides visiting our websites you can also follow us on social media. At [www.youtube.com/DanfossHeating](http://www.youtube.com/DanfossHeating) you can find our videos. Just click on 'Hydronic Balancing & Control' at the right side of the menu. Or stay up to date by following us on Twitter at [www.twitter.com/DanfossBalance](http://www.twitter.com/DanfossBalance)

