

ENGINEERING
TOMORROW

Danfoss

Danfoss *Dynamic Valve*™

The **simple solution** to a daily challenge

Optimal temperature control and automatic hydronic balancing for two-pipe heating systems – all in a single valve.

2-in-1 valve design

The *Dynamic Valve*™ combines a thermostatic radiator valve and a pressure controller for accurate temperature control and automatic hydronic balancing in a single product.

www.heating.danfoss.co.uk

Automatic hydronic balancing made very simple

With the launch of *Dynamic Valve™*, we have put all the advantages of automatic hydronic balancing within reach of anyone aiming to optimize the performance of two-pipe heating systems.

The ability to accurately balance and control the radiators in two-pipe systems at any load is the key to achieving better performance, reduced energy use and increased user satisfaction.

Simple to fit, easy to use and extremely durable, the innovative *Dynamic Valve™* instantly eliminates common problems like noisy radiators, uneven heat distribution and high levels of energy waste.

One product. One solution. One long list of benefits.

Fast planning, trouble-free installation and easy commissioning

No matter if you are specifying, installing or commissioning a heating system – for a renovation or new-build project – the *Dynamic Valve™* makes your life easier and creates an extremely efficient system. From the diagnostics to the system handover, each step is easy and intuitive.

Simplicity all the way

Using *Dynamic Valve™* means fast and easy system diagnostics. A simple design approach and fewer components that need dimensioning means faster planning. This adds flexibility to your project and workflow management. Simply calculate the required flow level at each radiator and prepare your commissioning documents.

Once the valves have been installed commissioning is as easy as setting the scale to its correct preset value.

Increased energy efficiency

Improved temperature control leads to increased user comfort and reduced energy consumption. The valve reduces heat loss and provides full control of the system delta T, resulting in improved boiler or community heating efficiency.

Furthermore, less water circulates through the system, making it possible to optimize pump settings or even reduce pump size.

Reliable system operation

With the *Dynamic Valve™*, the system will be permanently optimized to respond to changing weather conditions or user behavior.

Even when users adjust the radiator thermostat or valve settings, they cannot disturb the system balance. Together with the proven long-lasting quality of Danfoss sensors, reliable system operation will increase occupant satisfaction and lead to fewer installer call backs.

Say hello to *Dynamic Valve*TM

– the 2-in-1 temperature control and automatic balancing valve



Easy to work with

- 2-in-1 valve design
- Fewer system components
- No Kv or authority calculations
- Simple pressure verification

Efficient as never before

- Improved temperature control
- Increased user comfort
- Reduced energy consumption via pump optimization
- Greater boiler or community heating efficiency

Reliable operation

- Permanently optimized system
- Users cannot influence the system balance
- Fewer call backs
- Reduced comfort complaints

A new approach to system balancing

For heating technicians, the main challenges in existing solutions result from variable system conditions due to pressure fluctuations. The key to the simple automatic solution provided by the *Dynamic Valve™* is the way it combines a regular thermostatic valve with a built-in differential pressure controller.

As a result, pressure fluctuations are eliminated, removing the cause of typical heating system complaints. In addition, *Dynamic Valve™* establishes a stable and comfortable system that cannot be affected by any radiator adjustments that occupants may make.

How the *Dynamic Valve™* works

The secret of *Dynamic Valve™* lies deep inside. The small built-in differential pressure controller ensures constant pressure across the control valve. Normal pressure fluctuations no longer affect flow through the radiators.

Using a simple 1 to 7+N scale, each valve can be quickly set to any maximum flow between 25-135 liters per hour. By appropriately setting each valve, flow through the system is restricted to a maximum level. In addition, the heating system is commissioned and optimized to its full energy-saving potential.

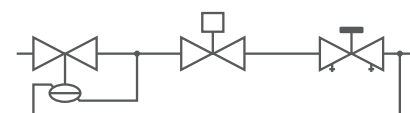

Dynamic Valve™ principle

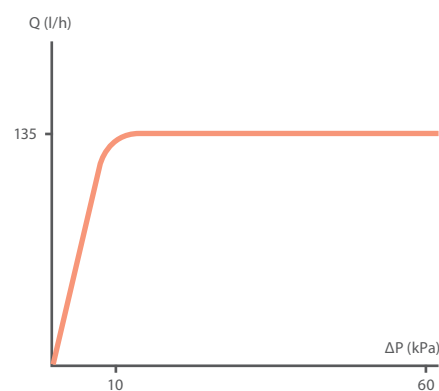

Dynamic Valve™ operation

Everybody wins

Good for building owners, good for occupants

Many of your customers will have experienced complaints about uneven heat distribution, noise from the heating system and high energy bills. With *Dynamic Valve™*, you can quickly and cost-effectively solve their issues.

Indoor comfort will be greatly increased by the even heat distribution and faster start-up times while noise in the heating system

will be eliminated. The energy efficiency increase and reliable system operation will reduce both energy consumption and the number of call outs. The result is a more efficient heating system with lower costs for everybody involved.

Benefits for your customers

- Fast, consistent and comfortable heating
- Silent heating
- Reduced costs

Scan the code and see how it works

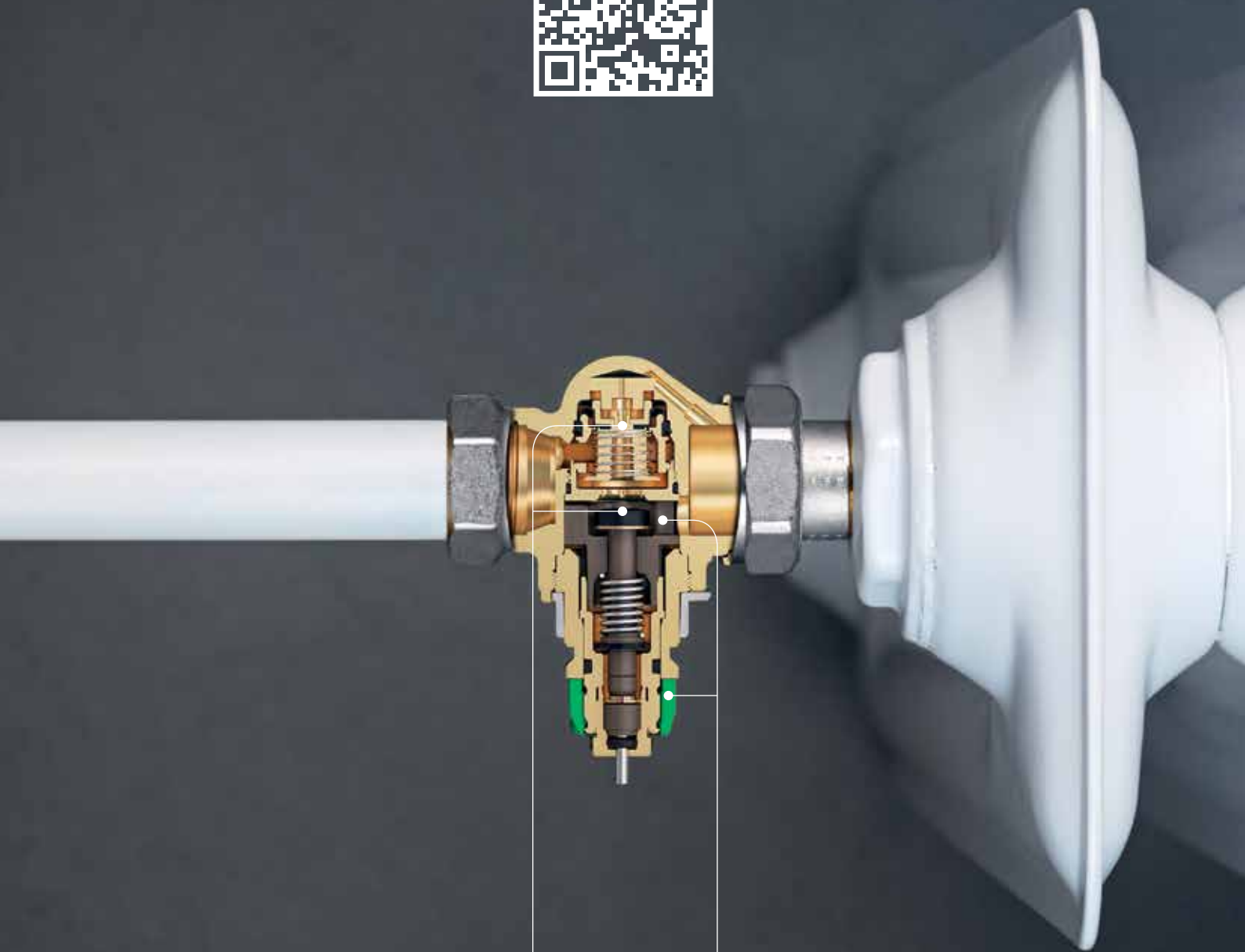

Built-in differential pressure controller:

This ensures that the entire heating system is automatically adapted and balanced, 24 hours a day, 365 days a year.

Valve cone: Determines the flow of water through the radiator, according to the sensor's temperature control.

Flow limiter: Ensures a maximum flow level through the radiator.

Setting scale: The simple 1 to 7+N scale corresponds to a flow range from 25-135 l/h. Setting can be instantly achieved without tools.

Understanding the challenges

In unbalanced or manually balanced systems, problems occur because of simple science: water always follows the path of least resistance, resulting in poor balance.

Manual balancing solutions help to achieve better balancing, but only under design, full-load conditions. In practice though, a heating system runs outside the design conditions in partial load most of the time.

Automatic balancing overcomes the challenges

To cope with the reality of constantly fluctuating system conditions, pump pressure is sometimes increased. This can lead to even bigger problems.

A far more effective solution is automatic balancing, with the goal of taking full control of the main challenge: securing system pressure at all loads.

Ever since the 1980s, Danfoss has offered the ASV automatic balancing solution for installation in system risers. Adding *Dynamic Valve™* to the product portfolio provides an alternative solution for installation at the radiators instead.

Achieving instant benefits

Automatic balancing provides instant benefits under all conditions. It is quick and easy to achieve and is a one-off investment with a fast payback time.



Eliminating pressure fluctuations is the key to both successful balancing and removing the source of user complaints about over- or under-heating, noise and excessive energy costs.

At the same time, the temperature sensors will benefit from the optimized system conditions, making temperature control more stable and precise.

Occupant issues

- Uneven heat distribution and differences in start up times
- Noise from the heating system
- Difficulty in controlling temperature

80-90%

of all two-pipe heating systems work inefficiently.

Economic issues

- High level of energy waste
- High heating bills
- High complaint-handling costs



Increasing awareness with great potential

Energy wasted by inefficient heating systems is a major issue worldwide. The need to reduce energy use in residential buildings in particular has moved to the top of the political agenda in recent years.

As these issues continue to gain in importance and legislation changes to reflect them, they will create excellent business opportunities for system specifiers and installers alike.

Automatic balancing solutions like the

Danfoss ASV and *Dynamic Valve™* are not just a highly effective way of exploiting this potential. Simplicity, minimal disruption during installation and short payback times make them an excellent investment for both renovations and new builds.

In short, there has never been a better time to choose a Danfoss automatic hydronic balancing solution.

Renovation⁺ concept

Renovation⁺ is a dynamic Danfoss solution to the urgent need to reduce the huge amount of energy currently being wasted in buildings across Europe.

The Renovation⁺ concept provides integrated smart solutions for the renovation or retrofitting of both one- and two-pipe heating systems. Offering a wide range of products and solutions, it is mainly aimed at upgrading the energy efficiency of existing heating systems in residential buildings.

Both *Dynamic Valve™* and the ASV solution are part of the Danfoss Renovation⁺ concept.



Choosing the right solution

With the arrival of the *Dynamic Valve™*, specifically designed for two-pipe systems, Danfoss can now offer a complete portfolio of products and solutions for any size of heating system.

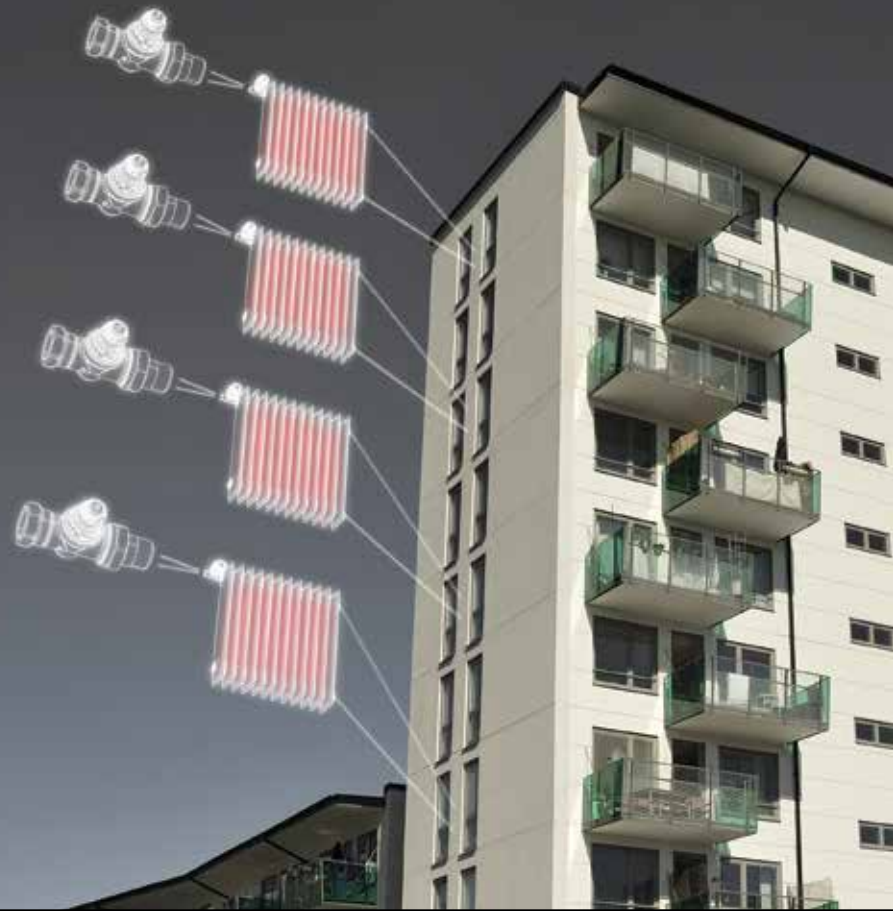

Which solution is ideal for your project?

To help you make the correct choice to achieve a robust, automatically balanced heating system, we have grouped the most important topics together in the table to the right.

Dynamic Valve™ was specifically developed to offer a simple solution for a wide range of buildings using two-pipe radiator systems and a pump head capacity of up to 6 meters (60 kPa*). With a maximum flow capacity of 135 l/h, it is compatible with most existing radiators.

Technical versatility

For ultimate versatility, Danfoss ASV valves offer the ideal solution for riser installations in buildings with pump capacities higher than 6 meters (60 kPa). ASV has no real technical limitations.

Practical convenience

From a practical point of view, *Dynamic Valve™* is the ideal solution for complex engineered systems, in which risers are difficult to access or where they are situated at some distance from each other.

In systems with well-functioning pre-setting radiator valves, the ASV solution is usually the best choice. This also applies for systems using radiators with built-in valves or in other situations where *Dynamic Valve™* cannot be used, for whatever reason.

Cost efficiency

From an economic perspective, *Dynamic Valve™* is the best choice for heating systems with few radiators per riser. In situations where there are a lot of radiators connected to each riser, the Danfoss ASV solution is more cost-effective.

* In partial load conditions the pump head can be the same as the differential pressure over the nearest radiator valves. The maximum allowed differential pressure over the *Dynamic Valve™* is 60 kPa.





Radiator-fitted
Dynamic Valve™

Fitted directly to each radiator, without the need for any additional components in the risers, it automatically ensures constant hydronic balancing throughout the system, no matter how conditions may change.

Riser-fitted
ASV solution

Fitted directly to the risers, it automatically ensures constant riser pressure, regardless of user behavior or sudden changes in the weather or other conditions. With radiator flow limited via regular Danfoss RA-N valves, the heating system is perfectly balanced.

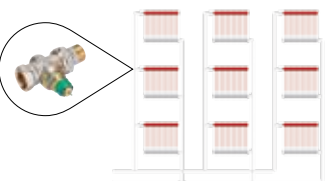
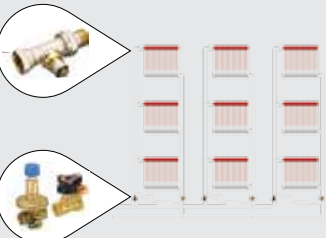

Solutions	 Pressure	 Radiator	 System	 Economy
<p>Radiator fitted RA-DV</p> 	<p>Max. differential pressure = 60 kPa</p>	<p>Max. flow = 135 l/h P = 3140 W at $\Delta T = 20K$ P = 4700 W at $\Delta T = 30K$</p>	<ul style="list-style-type: none"> • Best choice for complex riser designs • Best choice when main risers/return pipes are difficult to access • Best choice when main riser/return pipes are distant from each other 	<p>Best choice for risers with few radiators</p>
<p>Riser fitted ASV + radiator fitted RA-N</p> 	<p>Max. differential pressure = 150 kPa</p>	<p>No flow (l/h) limitations</p>	<ul style="list-style-type: none"> • Best choice if the max. differential pressure is unknown • Best choice when well-functioning pre-setting valves are present • Only choice for systems with built-in valves 	<p>Best choice for risers with many radiators</p>

Choosing the correct sensor for your project

Because the Danfoss *Dynamic Valve*™ uses the well-known RA sensor connection there is a wide range of sensors to choose from.



RA 2000

For optimum temperature control, choose RA 2000 gas-filled sensors.



RA 2920

For public buildings or other 'heavy-duty' situations the tamper proof sensor provides a robust solution.



Smart tools make things even simpler

We have developed two tools to make installation even simpler and guarantee correct dimensioning. The Pre-setting tool helps you to make the correct setting in situations where the setting scale is hard to read. It is also a highly convenient tool in cases where multiple radiators will be given a similar setting.

The dP tool™ is an extremely useful, simple and unique tool used during commissioning. It measures the available differential pressure. Not via an additionally installed measuring

orifice or manual balancing valve, but directly in the *Dynamic Valve*™. Use it on the valve furthest from the pump to check whether the available differential pressure is the required 10 kPa. If it is, you can be sure of a correctly commissioned system. In addition the dP tool™ can be used to see if extra cost savings can be achieved by reducing the pump head setting. Often a pump can provide the required differential pressure at lower than maximum setting.



Scan the QR code to see how the dP tool™ is operated.

2,200
units tested

in 17 different heating
systems throughout 6
countries.

Proven solutions

From small buildings to the very largest buildings, Danfoss offers you proven automatic balancing solutions for every size of project.

Although the *Dynamic Valve™* is a recent product, we already have a great deal of evidence of its practical effectiveness and reliability. During the product

development process, we conducted field trials involving the installation of over 2,200 units.

The test results we gathered during this process represent the most comprehensive pre-launch testing we have ever carried out on a valve.

Danfoss automatic balancing solutions

With the Renovation+ concept, Danfoss offers you an integrated range of products and solutions for any renovation, retrofitting or new build project. Within this context, the *Dynamic Valve™* completes our offering by providing a radiator-fitted solution for two-pipe heating systems in many types of buildings.

Dynamic Valve™ product range

Description	Model	Version	Connection	Flow (l/h) *	Code number
RA-DV 10	Angle	DIN	3/8"	25-135	013G772100
RA-DV 10	Straight	DIN	3/8"	25-135	013G772200
RA-DV 15	Angle	DIN	1/2"	25-135	013G772300
RA-DV 15	Straight	DIN	1/2"	25-135	013G772400

* 20-125 l/h including a gas filled RA 2000 sensor

Pre-setting tool

For easy pre-setting of a
Dynamic Valve™

Code number: 013G783000

dP tool™

For simple verification of sufficient
differential pressure and pump optimization

Code number: 013G785500

Experience *Dynamic Valve*[™] for yourself

Visit www.heating.danfoss.co.uk to find technical information, case studies and tools.

**The future of automatic hydronic balancing is here
– find out more today.**



Danfoss Ltd · Ampthill Road · Bedford · MK42 9ER

Telephone: 01234 364621 · Email: ukheating@danfoss.com · Web: www.heating.danfoss.co.uk

Danfoss can accept no responsibility for possible errors in catalogues, brochures, and other printed material. Danfoss reserves the right to alter its products without notice. This also applies to products already on order provided that such alterations can be made without subsequential changes being necessary in specifications already agreed. All trademarks in this material are property of the respective companies. Danfoss and the Danfoss logotype are trademarks of Danfoss A/S. All rights reserved.