



20%

energy savings

when choosing a suitable system with CO₂ compared to traditional systems with HFCs.

Transcritical CO₂ mini-booster controller for convenience and discount stores

- * Robust performance and proven transcritical control algorithms
- * More than 10 years field experience
- * Dedicated controller optimized for small stores with CO₂ Refrigeration systems
- * Graphical display for on-site supervision and service, improved user interface
- * Increased energy efficiency through COP optimization and easy-to-set up heat reclaim
- * Makes CO₂ transcritical systems easy to operate, safe and affordable



AK-PC 772 Controller for transcritical CO₂ mini-booster packs

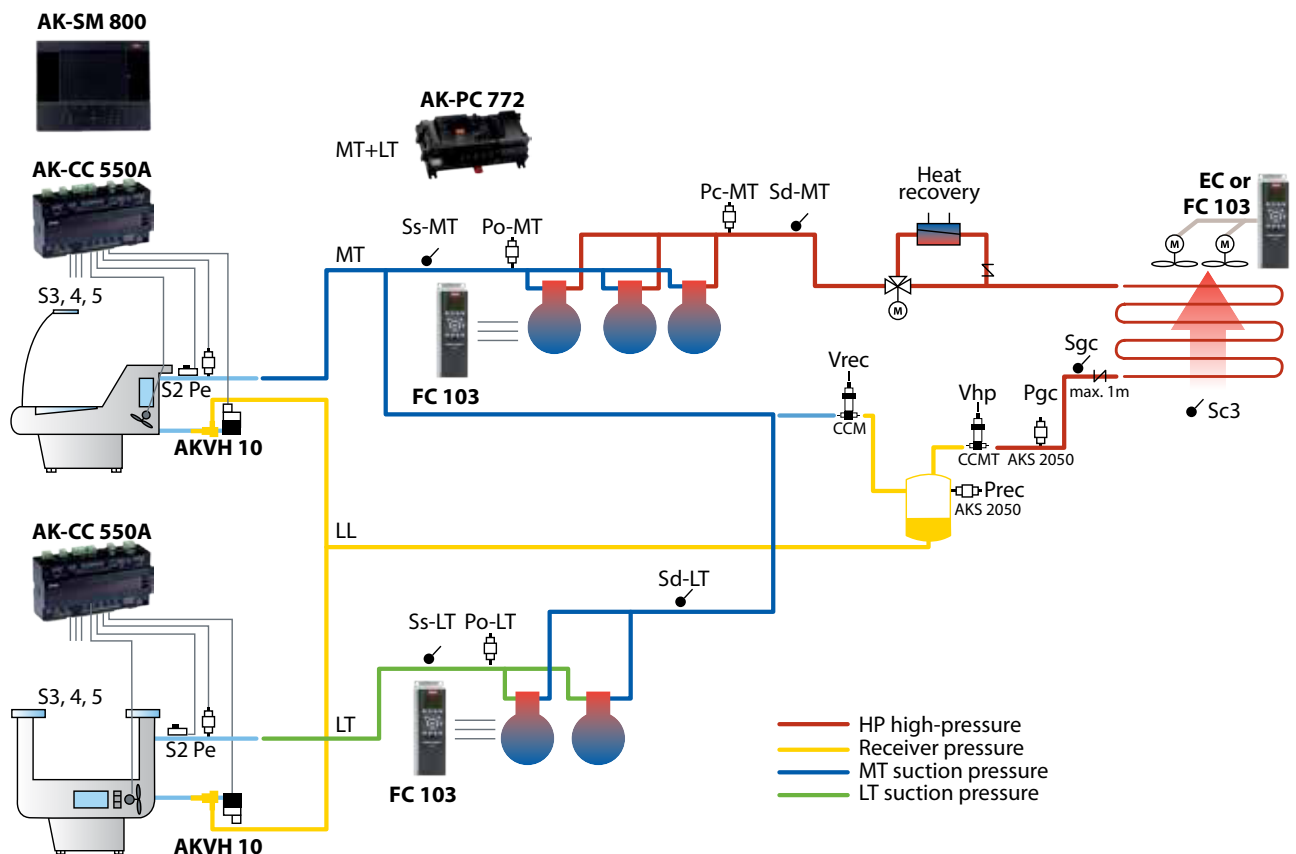

A cost-effective control solution integrating:

- High-pressure and receiver control (CO₂) with COP optimization
- Compressor and condenser capacity control (Gas Cooler)
- Multi-speed control (lead compressor, fan)
- Energy-effective heat reclaim for hot tap water and store heating

Complete ADAP-KOOL® solution for small stores:

- **AK-SM 800** series - System Manager for monitoring and system optimization of complete refrigeration systems, including alarm and HACCP monitoring; WEB server for remote supervision and service
- **AK-PC 772** - Pack control for 3 MT and 2 LT CO₂ compressors, integrated high-pressure receiver and gas cooler control, as well as heat reclaim
- **AK-CC 550A** - Display Case and Room Controller, including ADAP-KOOL® Adaptive Superheat Control with electronic expansion valve type AKVH 10 for CO₂