

ENGINEERING
TOMORROW

Danfoss

Increased **Savings** With **MicroChannel** Heat Exchangers

60%

lower weight

than a copper fin-and-tube coil for reduced shipping costs and easier handling.

The first part of the document discusses the importance of maintaining accurate records of all transactions. This includes not only sales and purchases but also any other financial activities that may occur. It is essential to ensure that all entries are properly documented and supported by appropriate evidence.

In addition, the document emphasizes the need for regular reconciliation of accounts. This process involves comparing the company's internal records with external statements, such as bank statements or supplier invoices, to identify any discrepancies. Regular reconciliation helps to prevent errors and ensures that the financial data is up-to-date and accurate.

Another key aspect of financial management is the timely payment of bills and invoices. Failure to pay on time can lead to strained relationships with suppliers and potential penalties. Therefore, it is crucial to establish a clear payment schedule and to monitor the status of all outstanding payments.

Finally, the document highlights the importance of maintaining a clear and organized system for managing financial documents. This includes keeping all receipts, invoices, and other relevant documents in a secure and accessible location. A well-organized system makes it easier to retrieve information when needed and helps to ensure the integrity of the financial records.

CONTENTS

KEEPING COOL, WITH HEAT EXCHANGERS	07
LOOK INSIDE AN MCHE A major step in applied heat exchanger technology	08
MCHE BENEFITS	10
MINIMAL USE OF REFRIGERANTS	12
A WORLD OF APPLICATIONS	16
RESIDENTIAL AC	19
COMMERCIAL AC	20
TRANSPORT REFRIGERATION	22
PRECISION COOLING	25
COLD ROOMS	26
THE MAKING OF AN MCHE	30
PROFESSIONAL, PERSONAL SUPPORT Round the world and round the clock	33
HOW CAN WE ADD VALUE TO YOUR BUSINESS?	34





THE FUTURE BELONGS TO MCHES

Superior coil technology

A quiet revolution is under way in the world of air-cooled condensers for refrigeration systems. MicroChannel heat exchangers (MCHES) are completely changing the way we look at things. Thanks to their excellent heat transfer and minimal use of refrigerant, MCHES are enabling the development of a whole new breed of efficient, low-impact products for AC units, refrigeration systems, transport cooling and other air-cooled applications.

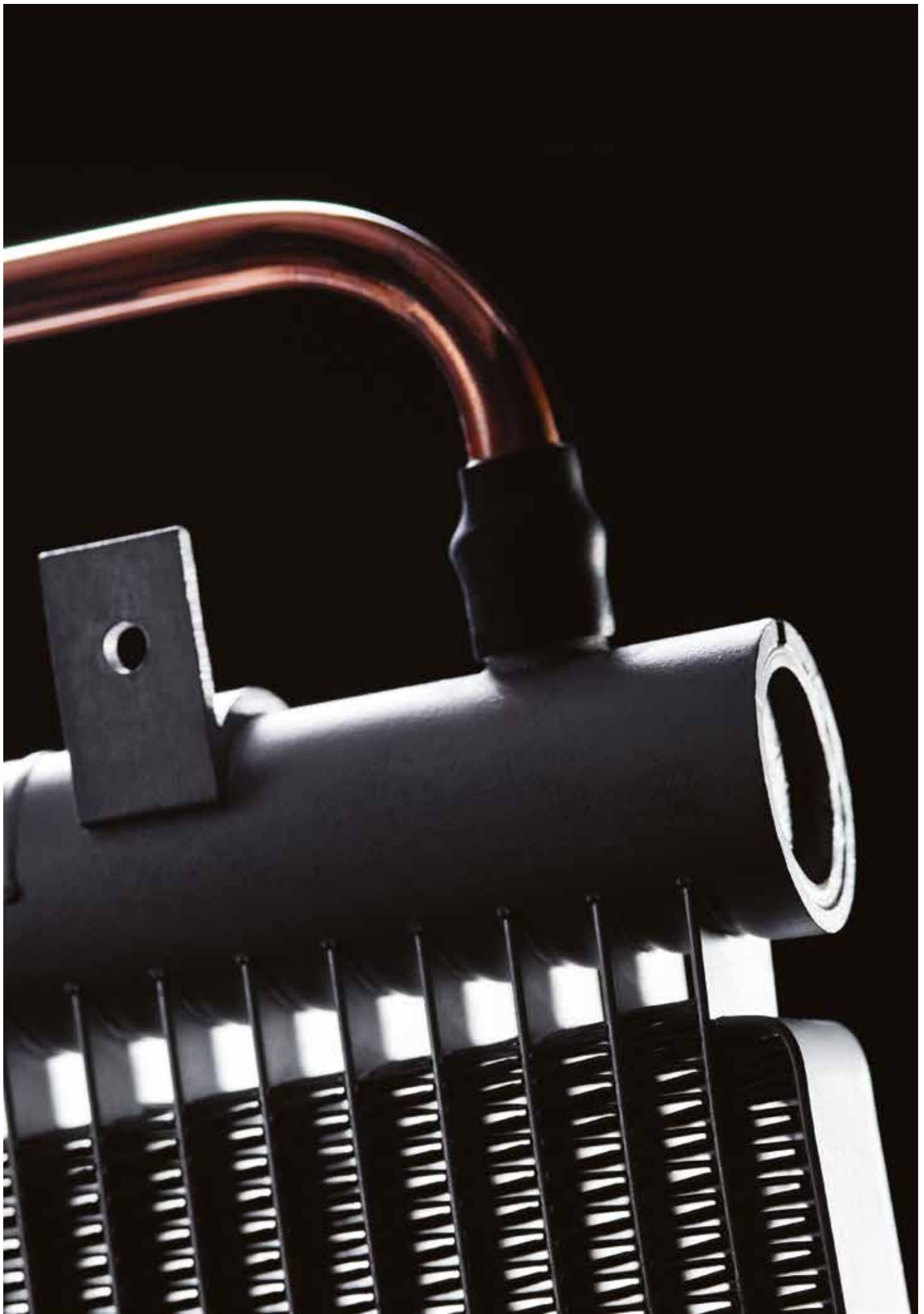

KEEPING COOL, WITH HEAT EXCHANGERS

Think of all the places where the air is at the ideal temperature. We breathe refreshingly cool air at home, in the office, the restaurant and the supermarket. Like many things, we simply take this luxury for granted. But what makes it possible? It's all about the heat transfer taking place in AC and cooling systems behind the scenes. And the key component of these systems is the heat exchanger. This little component, so easily forgotten, plays an absolutely central role. It's at the heart of every system, and its performance has a huge impact – not only on the user's comfort but also on ownership costs and the environment.

IT ALL ADDS UP

With MicroChannel heat exchangers, a cooling system requires less refrigerant, weighs less, takes up less space and consumes less energy. Multiply the savings millions of times over – in all the buildings in all the cities – and you start to understand what a positive impact MCHEs can have on our world.

Combining energy efficiency with minimal use of resources and refrigerants, MCHEs are very clearly paving the way for the development of greener cooling solutions, now and in the years to come.

LOOK **INSIDE** A MCHE

A major step in applied heat exchanger technology

MCHes have been used successfully in AC systems for the automotive industry for many years. Now we are developing this successful heat exchanger technology for use in new areas such as residential AC and commercial cooling applications.

RAPID CONVERSION TO MCHes

Given today's environmental concerns and the mounting pressure to develop more energy- and resource-efficient products, it is easy to see why MCHes are steadily gaining ground over traditional F&T coils. They improve COP by around 10% and require around 30% less refrigerant, paving the way for lighter, more compact products. Over the next five years, the market share of MCHes is expected to rise from 3% to 40%.

Explore the cost, resource and energy efficiencies of our light, compact MCHes on the following pages.

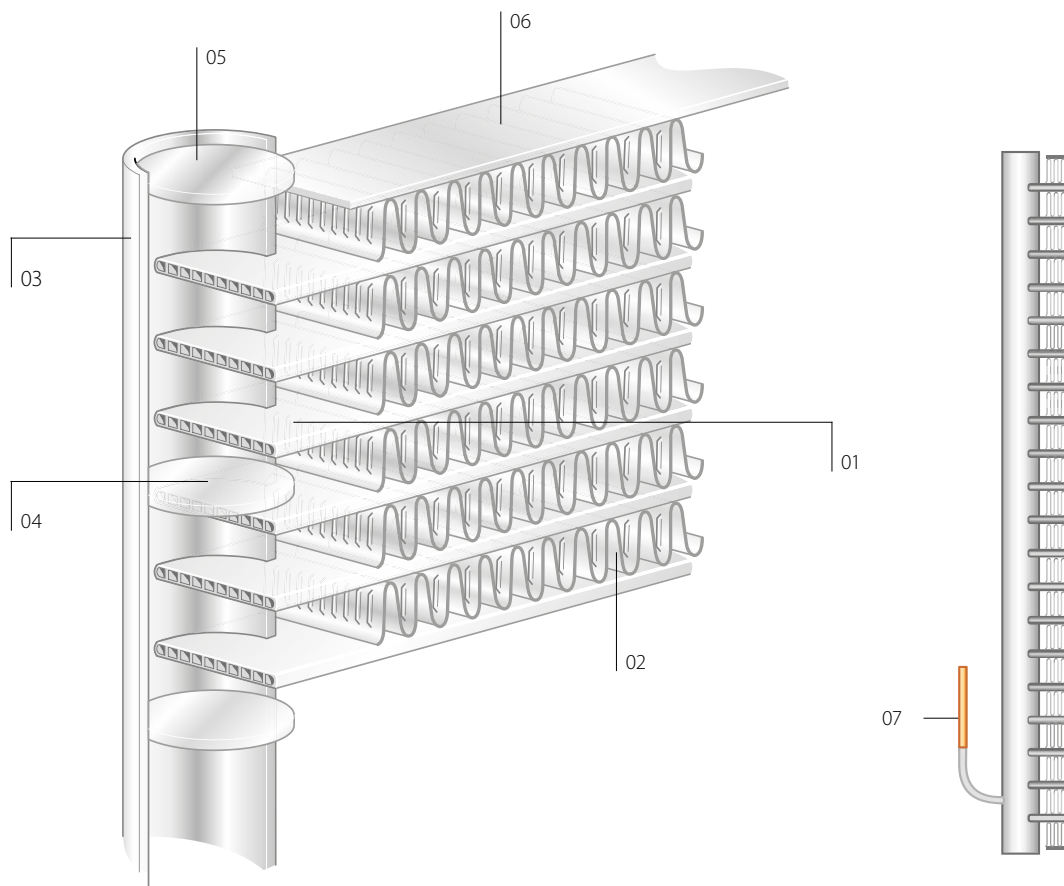

- 01 TUBE
The ingenious design of the tubes gives superior heat transfer, which in turn enables a more compact, but equally effective solution overall.
- 02 FIN
A superior louvred fin design maximises the surface contact. This reduces the air side pressure drop and improves efficiency, as well as reducing noise levels.
- 03 HEADER
In combination with baffles, MCHE headers control the flow of refrigerant and enable optimisation of the velocity in all phases.
- 04 BAFFLES
In combination with headers, MCHE baffles control the flow of refrigerant and enable optimisation of the velocity in all phases.

- 05 END CAP
The end cap and the main body of the MCHE are brazed together to form one leak-free stable unit. Being made entirely of aluminium, the whole heat exchanger (including the end cap) is resistant to galvanic corrosion.
- 06 SIDE PLATE
The side plates can be formed in different ways to simplify installation, using accessories, brackets and L- and U-bars.
- 07 CONNECTIONS
A wide choice of connection options makes it easy to adapt your products to customers' needs. Our standard and block connections of all types enable smart, space-saving piping solutions.

MCHE BENEFITS

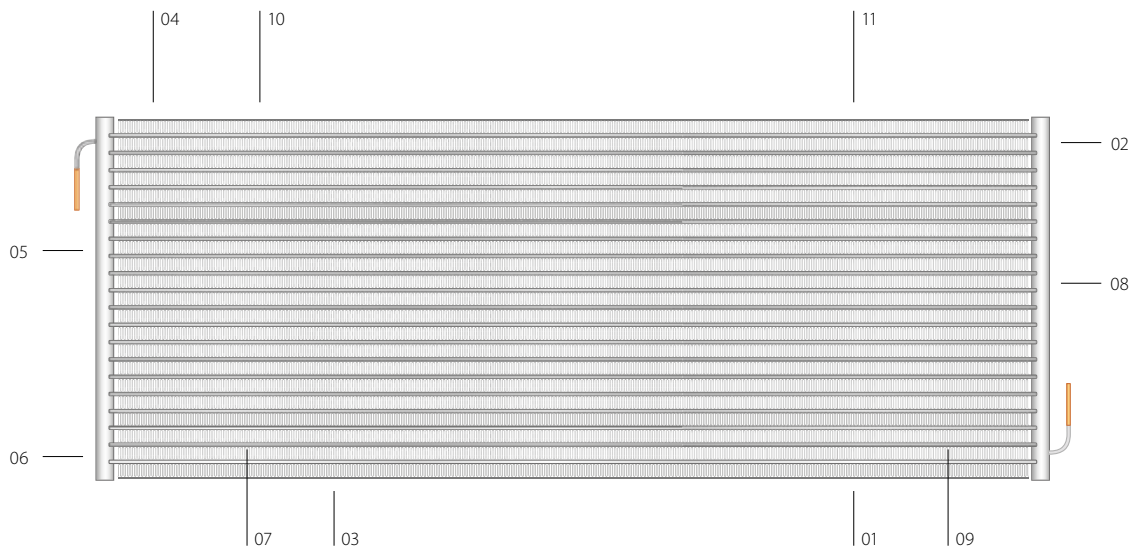

01 COMPACT DESIGN

The smart design of MCHEs means smaller coils can be used compared with an F&T coil of equivalent performance. Cooling units can be up to 35% smaller in size, which leads to further competitive advantages such as reduced footprint and smarter logistics solutions.

02 LOWER HOLD-UP VOLUME

The superior MicroChannel design delivers greatly improved heat transfer with less refrigerant. An MCHE's hold-up volume is a full 77% lower than that of an F&T coil.

03 LIGHT WEIGHT

MCHEs weigh 68% less than equivalent F&T coils. Their superior efficiency enables you to produce smaller, lighter units with equal performance. Their lightness also makes MCHEs cheaper to transport.

04 ALL-ALUMINIUM

MCHEs are made of aluminium, a low-density metal that prevents the galvanic corrosion which can occur between the aluminium and copper in F&T coils. Being made of a single material also makes it easier to recycle the product.

05 GREATER AIR-SIDE HEAT TRANSFER EFFICIENCY

MCHEs successfully address one of the limiting factors of coil performance and give higher air-side efficiency than F&T coils. They offer greater tube surface and better tube-to-fin joints as well as high and consistent contact between the metal surface and the ambient air.

06 BRAZED TUBE TO FIN JOINT

Air gaps reduce heat transfer. In an MCHÉ, all the parts are brazed together, so there are no air gaps in the joint between the fins and the tube so heat transfer is improved

07 EASY CLEANING

MCHEs are very easy to clean, unlike F&T coils from which dust and dirt are difficult to remove.

08 LOWER PRESSURE DROP PER UNIT HEAT TRANSFER

Pressure drop is lower in an MCHÉ, which allows you to use a smaller air side fan and reduce energy consumption. Alternatively, you can use the same fan to increase capacity.

09 PRICE STABILITY

Since they can be made very compact, MCHEs contain less metal than F&T coils. The metal content therefore represents a smaller proportion of the total cost, which makes MCHEs less vulnerable to raw material price fluctuations.

10 LOW NOISE LEVELS

MCHEs have an unobstructed airflow that reduces noise – a strong competitive advantage in residential AC applications. The straight-through air flow also gives a lower pressure drop and requires less fan power.

11 DESIGN FLEXIBILITY

Our comprehensive product range gives you maximum flexibility in both the size of the coil and your mounting options. MCHEs are available up to 1.5 x 4 metres, and we offer a range of mounting accessories to suit every type of installation.

MINIMAL USE OF REFRIGERANTS

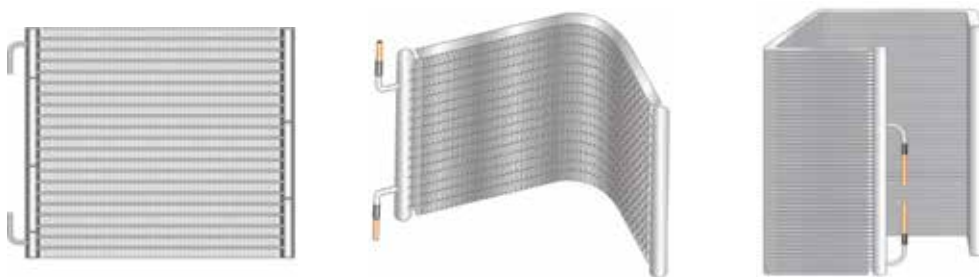

With environmental challenges in ever-sharper focus, it is only natural that the use of refrigerants should come under close scrutiny. The industry is responding to market demands for more environmentally friendly solutions by phasing out older refrigerants and introducing environmentally preferred alternatives. R407C, R410A and R134a are those most commonly used today.

We at Danfoss are helping to advance this positive trend by developing product lines that are fully optimised to work with modern refrigerants.

We now also offer the market our unique MCHs, which require a 30% lower refrigerant charge than traditional F&T coils. This enables low-impact products and helps customers meet modern environmental regulations. It also has a positive impact on costs, lowering initial purchase costs and reducing the need for inspections throughout the product's lifetime.

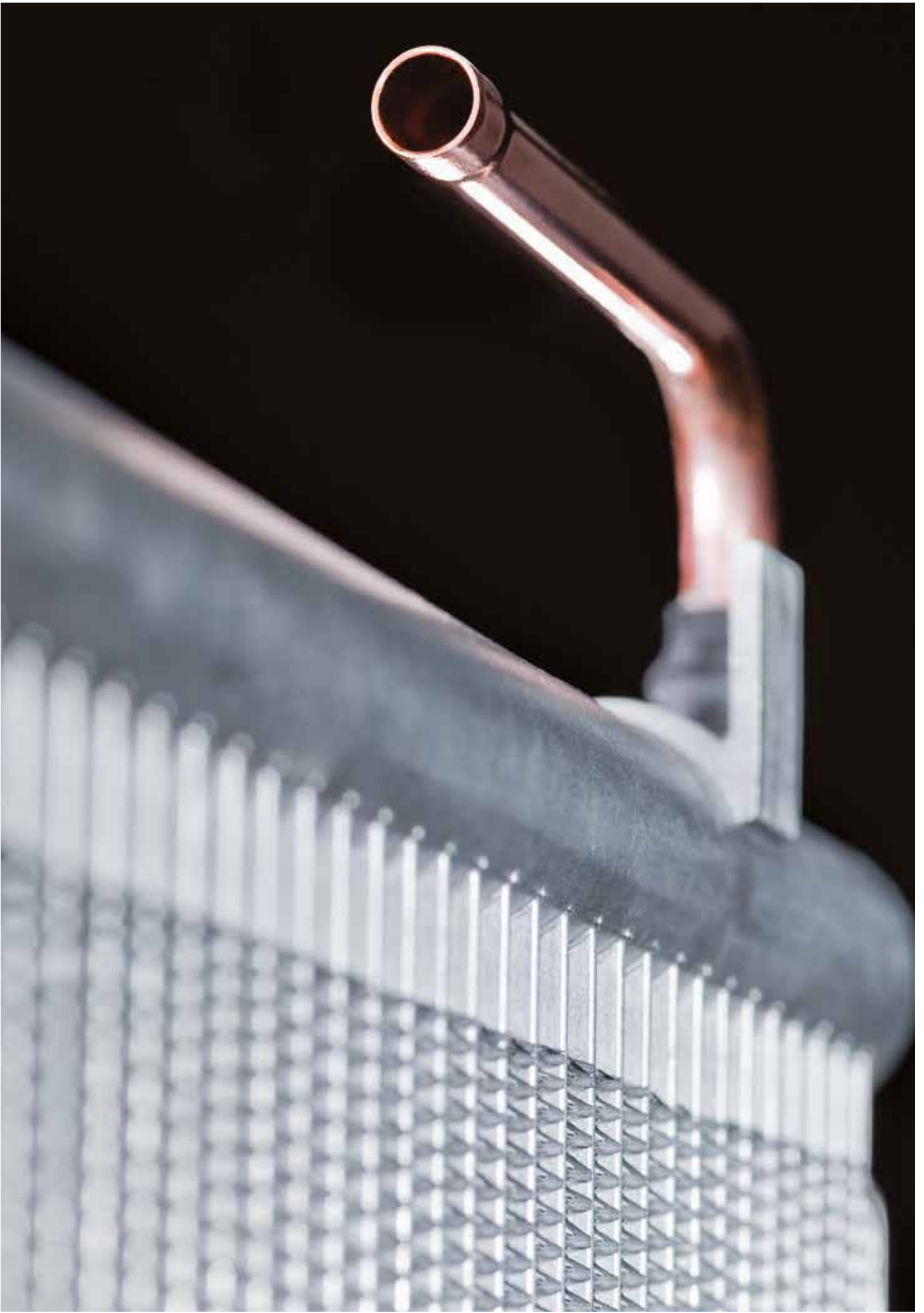



€60

Easy cleaning

Brazed fins are strong and easy to clean, reducing ownership costs throughout the product's lifetime.

€337

Lower energy consumption

Brazed fins are strong and easy to clean, reducing ownership costs throughout the product's lifetime.



€6

**Corrosion
resistance**

100% aluminium MCHEs
are less vulnerable to
galvanic corrosion.

A WORLD OF APPLICATIONS



Choose from a range of MCHEs that work perfectly in your AC unit, refrigerated transport, cooling system or other air-cooled application. Whatever usage you have in mind, there's an MCHЕ or the potential to produce one that will give optimal results.

When you work with us, you can draw on our broad knowledge and experience of both the HVAC and refrigeration businesses. This gives us a major advantage over competitors, enabling us to apply MCHЕ technology to the business areas we know best. It also means we can see beyond the current industry landscape and interpret the direction of development in the years to come.

Our customers benefit from this knowledge in the form of superior heat exchanger products that enable the production of leaner, greener cooling systems. Using our MCHЕs, you can build systems that meet not only today's but also tomorrow's demands for greater resource and energy efficiency.



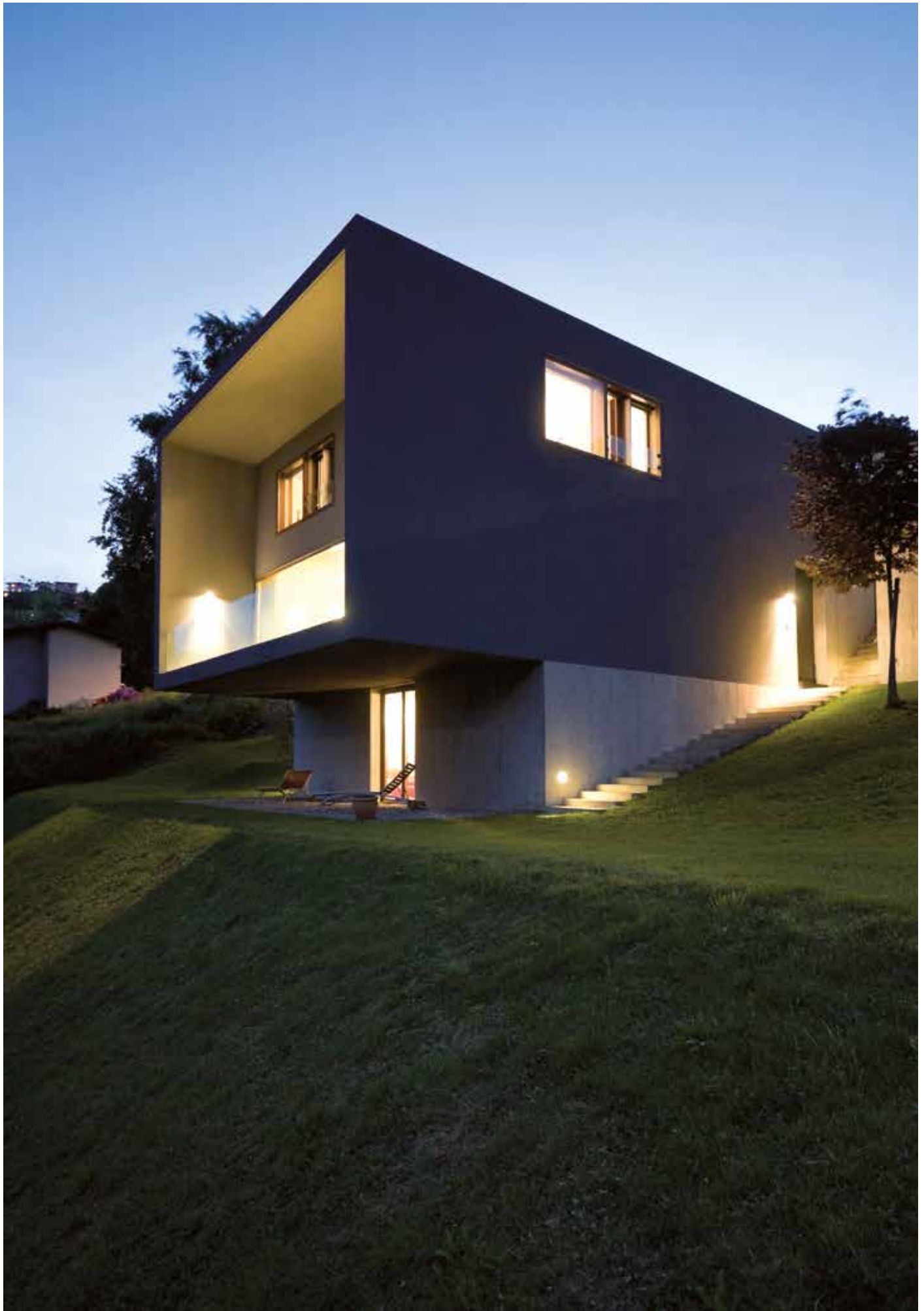

Key benefits • Higher system efficiency • Better environmental performance • Lower noise levels

MCHEs significantly improve the performance of outdoor condenser units in residential AC systems. Here's how:

First, their excellent heat transfer raises the efficiency of your products, enabling you to build a high-performance range with a smaller footprint. Add to this the MCHEs' minimal use of refrigerant and you are already closer to meeting today's stringent environmental regulations. MCHEs require 30% less refrigerant than traditional F&T coils, which reduces not just environmental impacts but also purchase and ownership costs. Another important advantage is the quietness of MCHEs, which means the AC unit can be placed close to a building without disturbing the residents.



Key benefits • Raise product efficiency or reduce footprint • Save money on raw material, transport, storage • Improve environmental performance and meet regulations • Attract customers with lean, MCHE-based products

In condensing units in commercial AC applications, MCHEs improve your bottom line in all the following ways:

First, their excellent heat transfer raises the efficiency of your products, enabling you to build a high-performance range with a slimmer design (for the same frontal area). With compact, energy-efficient products, you save on material, transport and storage costs – and increase the attractiveness of your offering to customers.

Another important advantage is that MCHEs have a 30% lower refrigerant charge than F&T coils, leading to environmentally friendlier systems. This means you can meet legal regulations, obtain environmental certification and take advantage of 'green' tax incentives.

Reach out to new customers with leaner, MCHE-based products that offer lower energy consumption and lower refrigerant charge (meaning fewer environmental inspections are needed over the product's lifetime).

TRANSPORT REFRIGERATION

Key benefits • Create high-capacity products for transport • Attract customers with reduced fuel costs and more cargo space • Improve environmental performance and meet regulations

With MCHEs you can address this market's key concerns.

Using MCHEs in your AC systems for refrigerated transport enables you to increase the capacity of your products. Alternatively, you can take advantage of the enhanced heat transfer of MCHEs to construct smaller, more compact but equally effective AC units. Also, since MCHEs are 68% lighter than an equivalent F&T coil, you can build lighter units that trim fuel costs. With a whole fleet on the road every day of the year, the savings soon add up.

Finally, remember that MCHEs also have a 30% lower refrigerant charge than an equivalent F&T coil, which enables you to produce environmentally friendlier AC systems and meet today's regulations.



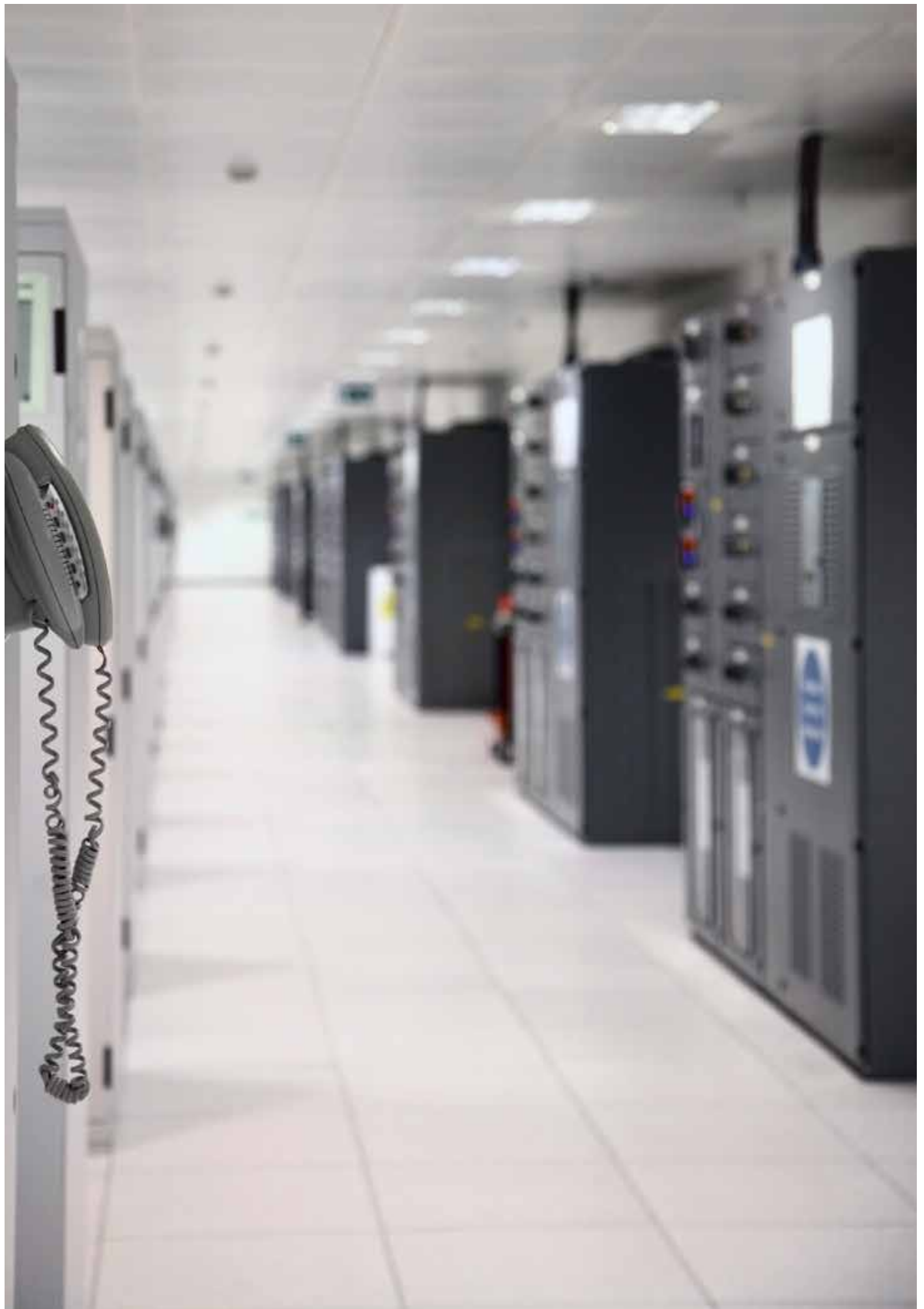

Key benefits • Precise temperature control to safeguard sensitive equipment • Compact, space-saving units • Low energy consumption • Meet environmental regulations

If you're in the business of precision cooling, MCHEs are the ideal choice of heat exchanger. You can take advantage of their precise temperature control to create cooling systems that reliably safeguard your customers' most sensitive technologies – in data centres, mobile phone network exchanges and server rooms.

You can also exploit their excellent heat transfer performance to design smaller, more energy-efficient cooling units. Your customers will appreciate the lower electricity bills as well as the space that's freed up for other things.

And remember, MCHEs require a 30% lower system refrigerant charge than equivalent F&T coils, so you can produce environmentally friendlier products and meet your markets' environmental targets now or in preparation for the future.

COLD ROOMS

Key benefits • Hygiene – very easy to clean • Build compact space-saving units • Reliable temperature control • Meet environmental regulations • Low energy consumption

MCHEs offer several major advantages in cold storage applications, for example in restaurants, food processing plants and supermarkets. These compact, efficient heat exchangers are very easy to keep clean, promoting the hygiene that is essential wherever food is involved.

MCHEs also offer a 10% better COP than F&T coils of the same size. This means the frontal area of the unit can be 35% smaller without reducing its effect. So you can produce neat, efficient systems that can be relied upon to keep cold store rooms at the right temperature, year after year.

Thanks to their low refrigerant charge, MCHEs also enable the production of more environmentally friendly products.





€17

Compact design

Lower raw material
costs, savings on storage.

The background of the entire page is a soft-focus photograph of green leaves, with some leaves in the foreground being sharper than others. The overall color palette is various shades of green, from light lime to deep forest green.

€26

Lower refrigerant charge

MCHEs require 30% less refrigerant than F&T coils.

€97

Reduced taxes

Taxes on refrigerant gases (HFCs) are lower thanks to minimal use of refrigerant.

THE MAKING OF A MCHE

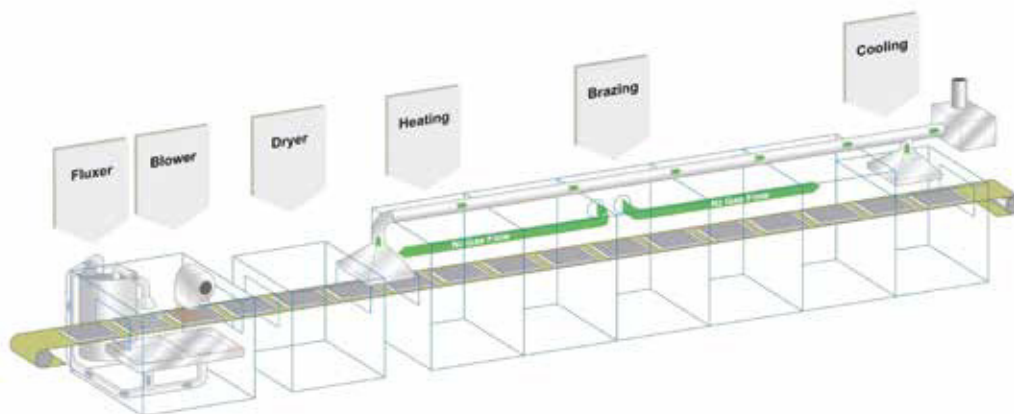

When you choose a new kind of heat exchanger for your application, you want to be sure it will perform smoothly. That's why we use every tool at our disposal, in our factories in North America, China and Europe, to guarantee the efficiency, quality and, ultimately, the reliability of the product we deliver to you.

In the production of MCHExs, we have adopted the high quality standards of the automotive industry. Every step in the production chain is quality-certified to ISO 9001 and TS16949. All the external parts used in our products are approved by third parties such as KHK, PED and UL.

Quality is checked and double-checked all the way from incoming goods to packaging and shipping. Before shipping, MCHEx products undergo thorough testing and inspections to ensure that they live up to our and our customers' expectations.

The production process involves seven steps designed to secure the best results and give our customers peace of mind.



01. Part production **02.** Assembly/Strapping **03.** Brazing **04.** Remove straps **05.** Mount in/outlet **06.** Leak test **07.** Packaging/Shipping



PROFESSIONAL, PERSONAL SUPPORT

Round the world and round the clock

As a customer-focused company, we pride ourselves on being able to guide you all the way from the first decision through installation and after-care. Applying our unrivalled knowledge of heat exchanger applications, we offer you best-in-class technical and commercial support, 24/7.

Tell us about your business and we can suggest a replacement for your existing heat exchangers and calculate your gains from upgrading. In the meantime, you can download our special software program from danfoss.com and carry out your own advanced heat exchanger calculations.

Thanks to widespread local operations, our skilled technicians are always close at hand to answer your questions after installation and help ensure your operations run smoothly from day one. Similarly, in the rare event of a malfunction, they can help you identify the cause and suggest a solution – wherever your business is based.

In our local, regional and global training centres, you can learn more about our MCHes. Attend a training course in person, or take advantage of our online training to study when it suits you.

As one of our partners, you gain access to our many years of accumulated heat exchanger experience and knowledge. We support you through the different phases of your product's life-cycle with personal service, based on the unique needs of your business.

HOW CAN **WE ADD VALUE** TO YOUR BUSINESS?

COMPONENT PHILOSOPHY

Our studies show that when you reduce the number of suppliers you work with by just one, you can reap significant financial benefits. The countless small efficiency gains – one less order to place, one less delivery to manage – combine to give an impressive reduction in your overall costs while reducing the carbon footprint of your end product.

Reducing your supplier base, even minimally, makes your life simpler. Working with us, an experienced and knowledgeable partner, makes it simpler still.

COUNT ON IT!

We've developed a methodology for measuring the value we can add to your business. We call this methodology 'Count on it'. What it means in practice is that before starting to work with a new customer, we conduct a thorough pre-study, taking the broadest possible range of factors into account. Based on the results of this pre-study, we calculate exactly how, and by how much, we can increase the profitability of your business. Why not meet us, no strings attached, and let us do the math?





A NATURAL CHOICE – HEAT EXCHANGERS

Our revolutionary MicroChannel heat exchanger technology enables us meet customer demands for clear, core savings and a better environmental performance. Our focus on customer solutions means we can identify the best way to help you meet current and future challenges – environmental, economic, legal or political – and help you develop your business.

Address

Danfoss can accept no responsibility for possible errors in catalogues, brochures and other printed material. Danfoss reserves the right to alter its products without notice. This also applies to products already on order provided that such alterations can be made without consequent changes being necessary in specifications already agreed. All trademarks in this material are the property of the respective companies. Danfoss and the Danfoss logotype are trademarks of Danfoss A/S. All rights reserved.