



**Applications:**



AVTB-RA is a reverse acting thermostatic temperature controller used to regulate the water temperature where cooling is required. As the water temperature rises the thermostatic controller opens.

Typical applications could involve:

- Injection molding machines
- Compressors
- Vacuum pumps
- Dry cleaning machines

The thermostatic controller is a three part assembly consisting of the valve body, the thermostatic element and an adjustment assembly.

**Features:**

- For water
- Self-acting
- Opens on rising temperature
- Can be fitted in the supply or return
- Pressure range PN 16 (232 psi/16 bar)

**Typical Application:**

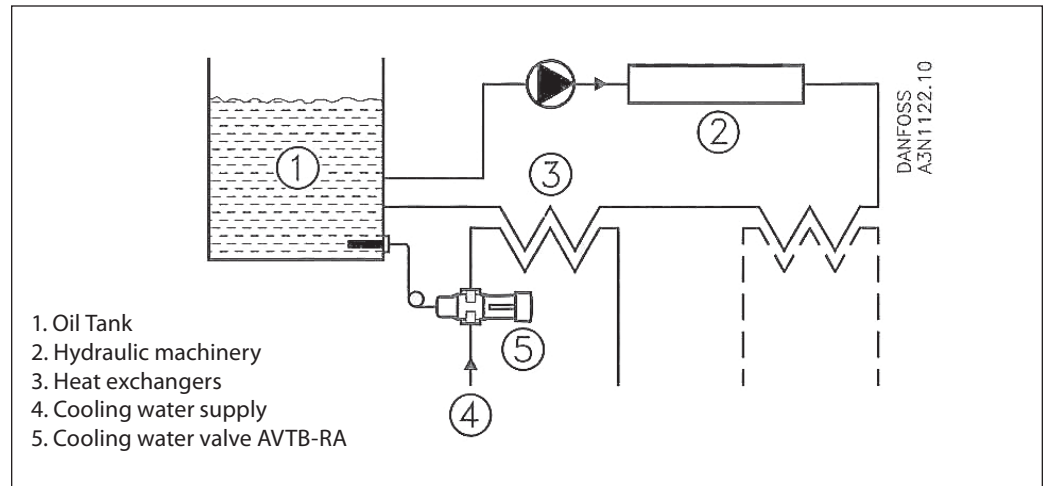

**Ordering Information:**

Code No.	Model	Connection (FNPT)	Capillary Tube Length	Max. Sensor Temperature °F (°C)	C <sub>v</sub>	Temperature Range °F (°C)
003N6032RA	AVTB-RA 15	1/2"	6' 6" (2.0 m)	130 (55)	2.2	32-85 (0-30)
003N6252RA				190 (90)		77-150 (20-60)
003N6272RA				255 (125)		125-190 (50-90)
003N7032RA	AVTB-RA 20	3/4"		130 (55)	4.0	32-86 (0-30)
003N7252RA				190 (90)		70-150 (20-60)
003N7272RA				255 (125)		125-190 (50-90)
003N8032RA	AVTB-RA 25	1"		130 (55)	6.4	32-86 (0-30)
003N8252RA				190 (90)		70-150 (20-60)
003N8272RA				255 (125)		125-190 (50-90)

**Ordering  
Information  
(Cont.):**

*Accessories*

Code No.	Components
<b>003N0056</b>	Capillary tube gland, 3/4" NPT
<b>003N0418</b>	Gasket for capillary tube gland
<b>AVTBWELL</b>	Sensor pocket, 3/4" NPT, brass
<b>003N0053</b>	Sensor pocket, 3/4" NPT, stainless steel

<sup>1</sup>Include gasket for capillary tube gland

*Spare Parts*

Code No.	Components	Cap. tube length ft (m)
<b>003N0075</b>	Thermostatic element 32-85°F (0-30°C)	6'6 (2)
<b>003N0078</b>	Thermostatic element 77-150°F (20-60°C)	
<b>003N0062</b>	Thermostatic element 125-190°F (50-90°C)	
<b>003N4006</b>	For 1/2"	Repair set: Two diaphragms, two O-rings, one rubber cone, one tube of grease and eight valve cover crews
<b>003N4007</b>	For 3/4"	
<b>003N4008</b>	For 1"	
<b>003N6100</b>	1/2"	
<b>003N7100</b>	3/4"	Brass AVT body and adjustment knob, less element
<b>003N8100</b>	1"	
<b>003N0520</b>	AVT spare handle	

**Design:**

1. Handle for temperature setting
2. Spring housing
3. Setting spring
4. O-ring
5. Diaphragm
6. Spindle
7. Valve body
8. Valve cone
9. Bellows
10. Bellows stop
11. Pressure stem
12. Temperature sensor
13. Capillary tube gland

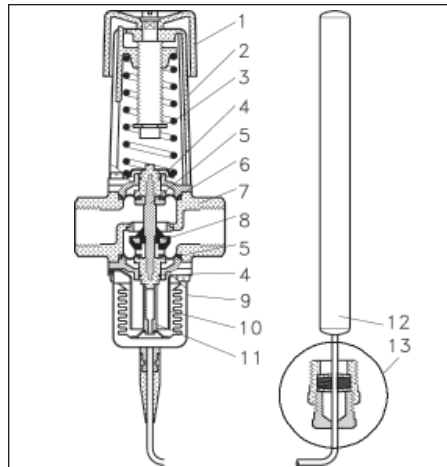

**Materials, parts in contact with water:**

- |                       |   |
|-----------------------|---|
| Valve body:           | Ms 58, hot-pressed                                |
| Other metal parts:    | Ms 58   |
| Diaphragms:           | EPDM rubber<br>(alt. NBR rubber for mineral oils) |
| Capillary tube gland: | NBR rubber  |
| Valve cone:           | NBR rubber  |
| Valve seat:           | CR Ni steel                                       |
| Sensor:               | Cu  |
| Sensor pocket:        | Ms 63   |

**Specifications:**

Supply temperature range:	-13°F to 266°F (-25°C to 130°C)
Maximum working pressure:	232 psi (16 bar)
Maximum differential pressure:	100 psi (7 bar)
Maximum test pressure:	365 psi (25 bar)

**Sizing:**

*Example*

Cooling water valve for temperature regulation of a vacuum pump. Regulation of the oil temperature is required. The sensor to be placed horizontally.

*Given*

- Necessary cooling effect at full load, 34,000 BTU/h
- Required oil temperature: 113°F (45°C)
- Cooling water pressure  $P_1 = 28.5$  psi (2 bar)
- Outlet pressure  $P_3 = 0$  psi (0 bar)
- Cooling water temperature  $T_1 = 77$ °F (25°C)
- Outlet temperature  $T_2 = 84$ °F (29°C), ( $\Delta T = 7$ °F (4°C))

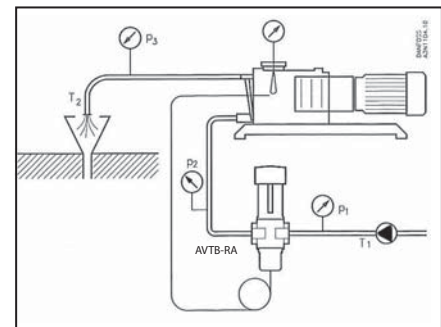

Sizing:

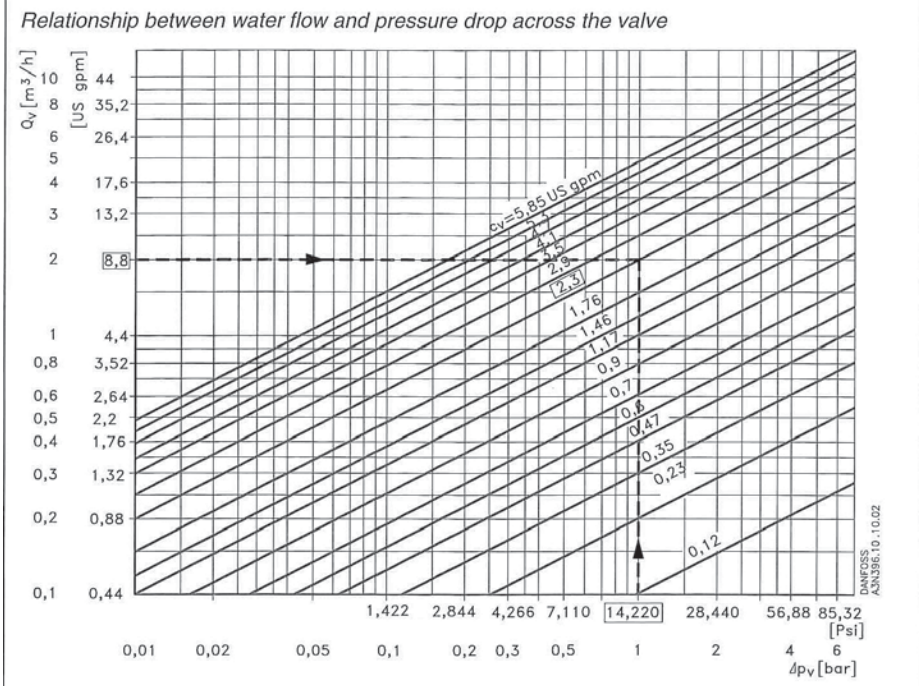
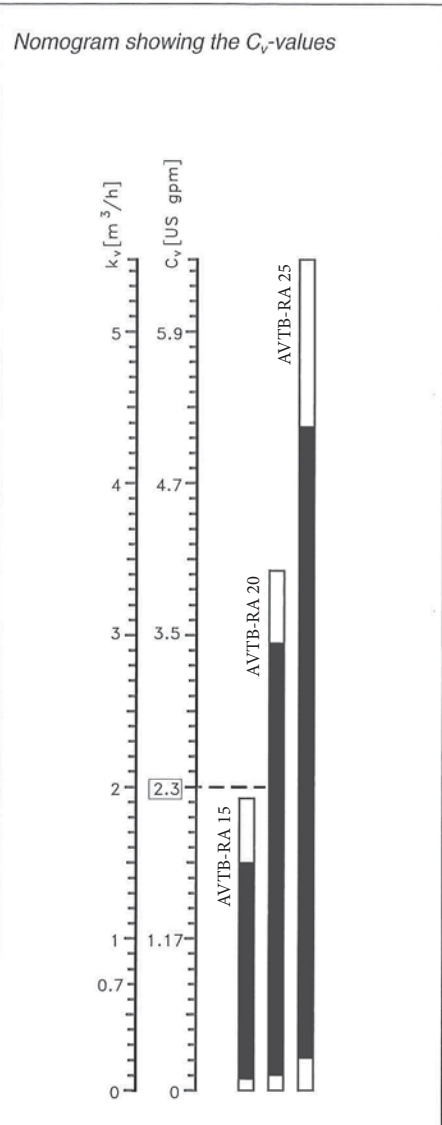
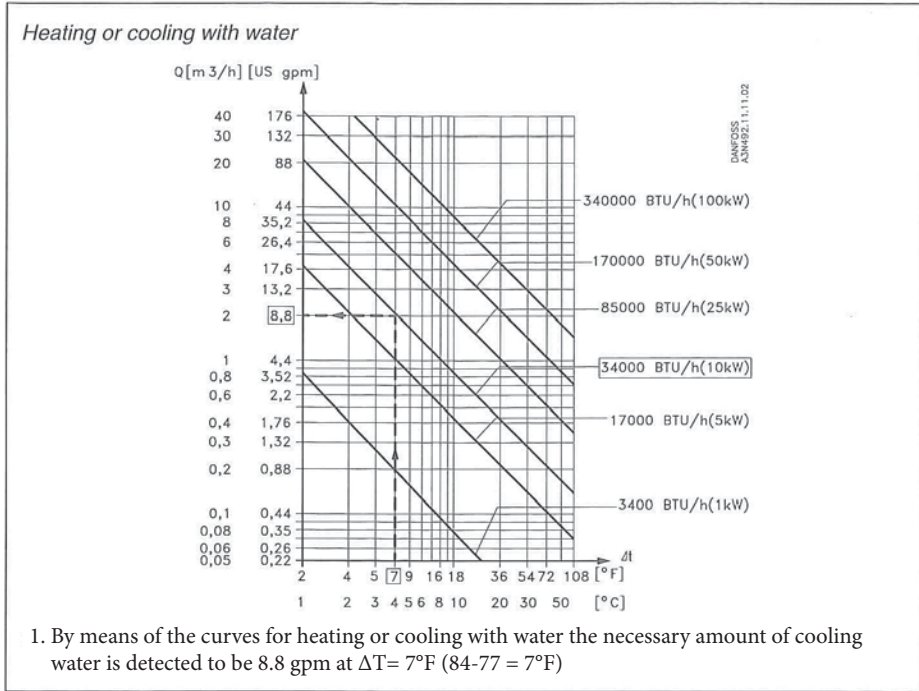

2. In order to obtain an effective regulation, the pressure drop across the valve should be half the entire pressure drop:  $28 \text{ psi} (2 \text{ bar}) / 2 = 14.22 \text{ psi} (1 \text{ bar})$ . By means of the curves for the water amount and pressure drop the necessary  $C_v$  value is detected to be 2.3 US gpm.

Temperature range: 77 to 150°F. Code no. 003N7252RA will meet the requirements

Due to the mounting conditions a sensor pocket is required. The 3/4" brass sensor pocket, code no. AVTBWELL is selected.

**Setting:**

Relation between scale numbers 1-5 and the closing temperature. The values given are approximate.

Scale setting	1	2	3	4	5		
Closing temperature (0 ... 30°C)		0	3	15	23	30	°C
(20 ... 60°C)	20		35	50	60	70	
(30 ... 100°C)30	35		55	75	95	120	
(32...85°F)		32	39	60	73	85	°F
(77...150°F)	77		95	122	140	158	
(125...190°F)	125		150	176	194	210	

**Installation:**

The valve can normally be fitted in the supply or return, in any position, provided the flow is always in the direction indicated by the arrow. Elements with a small sensor Ø 0.4" (9.5 mm) ("sensor warmer") must always have the valve housing fitted in the return.

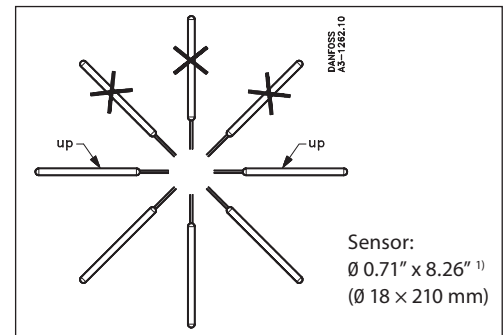

<sup>1)</sup> The sensor can be mounted where the system temperature is either warmer or colder than the temperature in the valve body

**Dimensions:**

Type	H <sub>1</sub> in (mm)	H <sub>2</sub> in (mm)	L in (mm)	L <sub>1</sub> in (mm)	L <sub>2</sub> in (mm)	L <sub>3</sub> in (mm)	L <sub>4</sub> in (mm)	a (int. thread)
AVTB-RA 15	8.54 (217)	5.24 (133)	2.84 (72)	0.56 (14)	5.6 (141)	5.87 (149)	2.95 (75)	½" NPT
AVTB-RA 20	8.54 (217)	5.24 (133)	3.55 (90)	0.63 (16)	6.06 (154)	6.45 (164)	3.15 (80)	¾" NPT
AVTB-RA 25	8.54 (227)	5.43 (138)	3.74 (95)	0.75 (19)	6.61 (168)	6.57 (167)	3.27 (83)	1" NPT

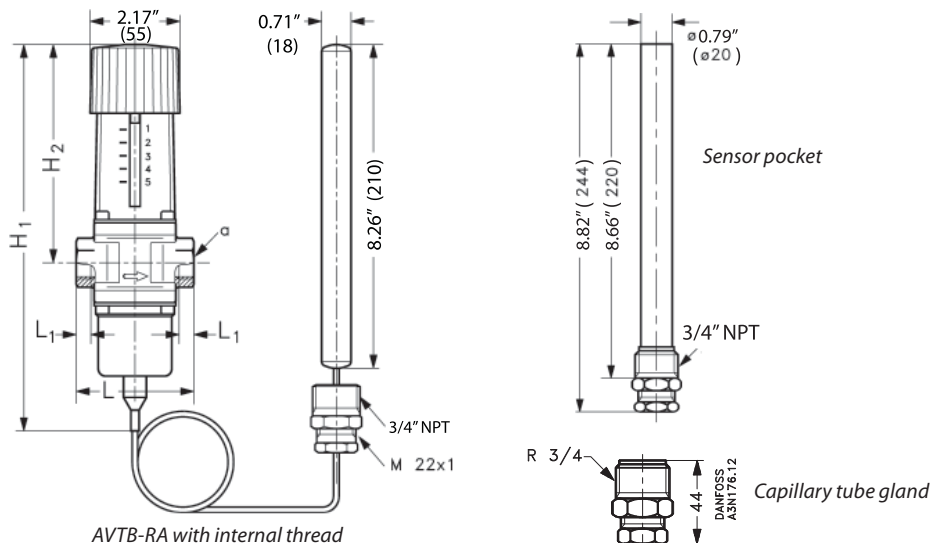

Danfoss can accept no responsibility for possible errors in printed materials and reserves the right to alter its products without notice. All trademarks in this material are property of the respective companies. Danfoss and Danfoss logotype are trademarks of Danfoss A/S. All rights reserved.



**Danfoss**  
Toronto, ON  
Toll Free: 866-375-HVAC (4822)  
Tel.: 905-285-2050, Fax: 905-285-2055  
www.na.heating.danfoss.com

**Danfoss**  
Baltimore, MD  
Toll Free: 866-375-HVAC (4822)  
Tel.: 443-512-0266, Fax: 443-512-0270  
www.na.heating.danfoss.com