

Data Sheet

Load Independent Proportional Valve

PVG 100

PVG 100 is a load independent proportional valve with flow up to 180 l/min [48 gpm] and pressures up to 350 bar [5076 psi]. It offers equitable flow sharing for precise control of multiple machine functions under varying load conditions and pressure requirements.

Building on the modular, flexible, and proven Danfoss load-sensing proportional valve concept, PVG 100 offers easy, fast configuration, thereby helping vehicle designers meet tight time-to-market deadlines. The new valve is positioned between the existing Danfoss PVG 32 and PVG 120 with flows up to 130 l/min [34.4 gal/min] and 240 l/min [63.4 gal/min] respectively.

PVG 100 optimizes system design for engineers who must incorporate new emissions restrictions by providing a more efficient hydraulic system that maximizes power and conserves energy. Typical applications include backhoes, telehandlers, wheel loaders, forklifts, and forestry equipment.

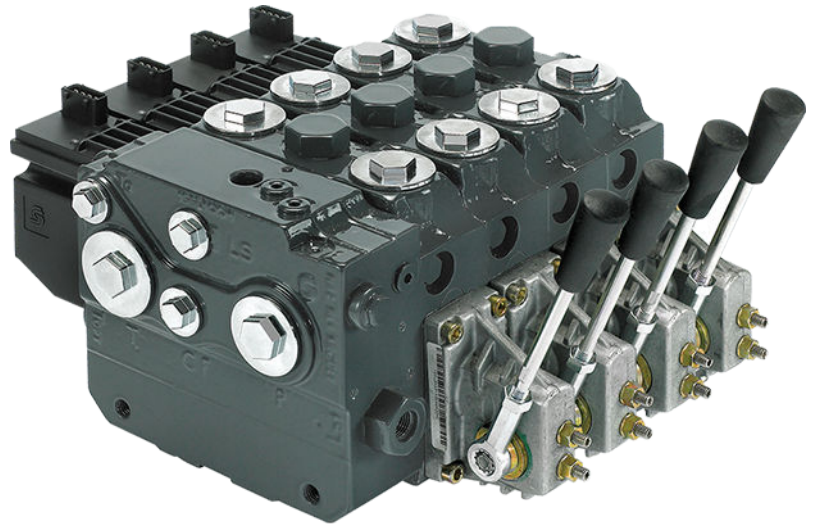

Features

- Flow sharing for maximum controllability and safety. All sections will continue to function regardless of load differences and pump flow.
- Load-independent flow control for smooth operation and improved productivity.
- Load-sensing technology for higher efficiency, safety, reduced energy consumption, and longer system lifetime.
- Configurable as advanced electrically controlled proportional valve as well as load-sensing directional control valve.
- Modular design providing a wide range of configuration possibilities.
- Up to eight different sections per valve group. Maximum flow per section: 180 l/min [48 gpm].
- Can be configured in combination with our range of HIC hybrid modules and/or PVG 32 for maximum flexibility.
- Mechanical, hydraulic, and electrical actuation options.

Comprehensive technical literature online
at powersolutions.danfoss.com

Sectional Drawing PVB

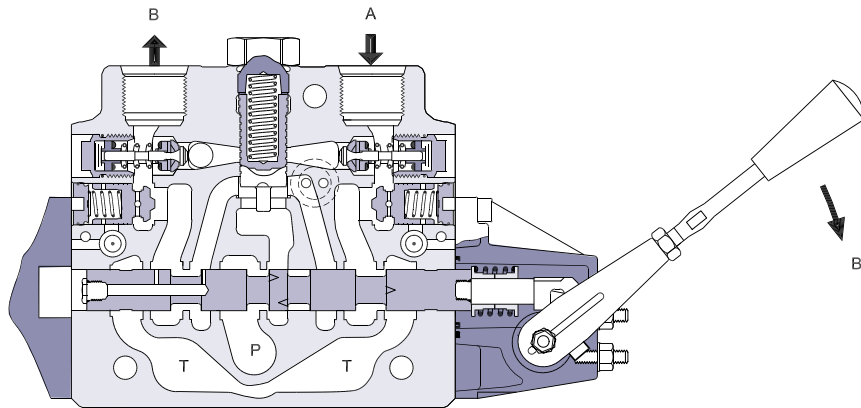

157-749.10

Technical Data PVG 100

Max. pressure	Port P continuous	350 bar	[5075 psi]
	Port A/B	350 bar	[5075 psi]
	Port T, static / dynamic	25 bar/40 bar	[365/580 psi]
	Port T0, static / dynamic	5 bar/10 bar	[75/145 psi]
Oil flow, rated (See characteristics,	Port P	250 l/min	[66 US gal/min]
	Port A/B, with press. comp.	180 l/min	[47.6 US gal/min]
Spool travel	Standard	± 7 mm	[±0.28 in]
Spool travel, float position spool P→B→F	Proportional range	5.5 mm	[±0.22 in]
	Float position	8 mm	[±0.32 in]
Dead band, flow control spools	Standard	± 1.5 mm	[±0.06 in]
Max. spool leakage at 100 bar [1450 psi] and 21 mm ² /s [102 SUS]	A/B to T, without shock valve	20 cm ³ /min	[1.85 in ³ /min]
	A/B to T, with shock valve	25 cm ³ /min	[2.15 in ³ /min]
Max. internal leakage shock valve pilot operated check valve at 200 bar [2900 psi] and 21 mm ² /s [102 SUS]	A/B to T, without shock valve	1 cm ³ /min	[0.06 in ³ /min]
	A/B to T, with shock valve	6 cm ³ /min	[0.37 in ³ /min]
Oil temperature (inlet temperature)	Recommended temperature	30 to 60°C	30 to 60°C
	Min. temperature	-30°C	[-22°F]
	Max. temperature	+90°C	[194°F]
Ambient temperature		-30 to +60°C	[-22 to +140°F]
Oil viscosity	Operating range	12 - 75 mm ² /s	[65 - 347 SUS]
	Min. viscosity	4 mm ² /s	[39 SUS]
	Max. viscosity	460 mm ² /s	[2128 SUS]
Filtration	Max. contamination (ISO 4406)	23/19/16	23/19/16