

Technical Information

Sensors

ACX104B Potentiometer Rotary Position Sensor

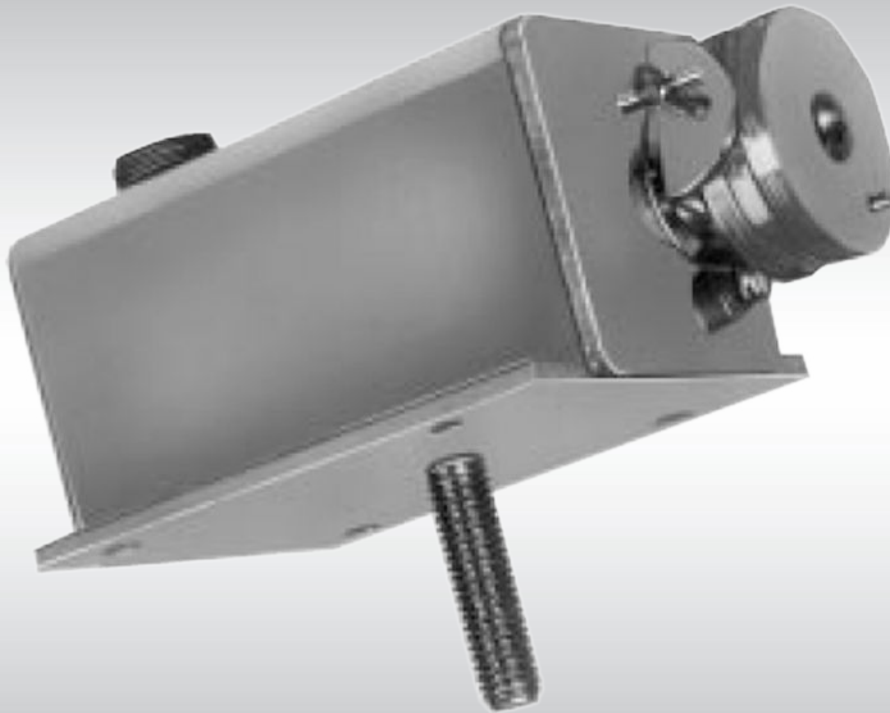

Revision history*Table of revisions*

Date	Changed	Rev
November 2015	Conversion to Danfoss layout	0001
July 2010	First edition	0000

Contents

Product overview

Description.....4
Features.....4
Ordering information.....4

Technical data

Electrical.....5
Environmental.....5
Weight.....5

Installation

Dimensions.....6
Location.....6
Mounting.....6
Wiring.....7

Product overview

Description

The ACX104B Potentiometer Rotary Position/Steering Sensor is a versatile control module applicable in a wide range of machine uses. In rotary position use, the sensor measures the relative height of the machine in relation to an external reference such as a stringline. In steering use, the sensor measures the machine's relative distance from a reference such as a curb. In both cases, the electrical signal is fed into a controller such as the ACE100A and, in steering usage, is compared to an ACX104C track or wheel feedback system. The ACX104B provides the necessary sensing control for rotary position or steering machinery such as asphalt or slipform pavers.

Signals come from an internal potentiometer that rotates directly with the outer hub. A follower attached to the hub provides a means of tracing a stringline or other reference surface. Follower movement rotates the shaft of the potentiometer, giving proportional signal to the controller. Typically the controller will be used to drive a V7059A Servovalve or KVF Flow Control Servovalve to reposition the machine as deviations occur.

Features

- Adjustable spring bias on the hub varies the follower tension on the stringline or reference surface
- Rugged housing
- Resists corrosion, moisture and other damaging environmental effects
- Compact unit can be mounted on almost any surface
- Connections between controller and sensor are made easily through MS connectors
- Easy to remove for service or replacement
- Two position (Run/Standby) switch available

Ordering information

Specifications

ACX104B1002	1 kilohm, 90° potentiometer, without switch.
ACX104B1028	Auto/Manual ON/OFF switch, no mounting tabs.
ACE100A	Controller, order if needed.
KVF	Servovalve
KW01009	Cable assembly, can be used to provide connections. The two-foot coiled cable extends to ten feet.
K04185	Mating connector
Follower	Order as necessary, see Wiring on page 7.

Technical data

Electrical

Data

Input voltage	24 Volts maximum
Output voltage	30% to 70% of input
Resistance	1000 ohms, +20%

Travel

Physical stops limit travel to approximately 20 degrees (18 degrees minimum). The potentiometer wiper is electrically centered when the indicator line on the hub is parallel to the mark on the case.

Phasing

Resistance between Pins A and B of the MS connector will increase when the hub is rotated clockwise.

Environmental

Vibration

Withstands a vibration test designed for mobile equipment devices that includes two parts:

1. Cycling from 5 to 2000 Hz over a range of +1.0 g's to +8.0 g's for a period of one hour (if there are four resonant points), for two hours (if there are two or three resonant points) and for three hours (if there is one or no resonant point). The cycling test is performed on each of the three major axes.
2. Resonance dwell for one million cycles over a range of +1.0 g's to +8.0 g's for each of the four most severe resonant points on each of the three major axes.

Shock

Withstands a shock test for mobile equipment devices that consists of three shocks of 50 g's and 11 milliseconds duration in both directions of the three major axes for a total of 18 shocks.

Temperature

Operating temperature	-18° to 77° C (0° to 170° F)
Storage temperature	-40° to 77° C (-40° to + 170° F)

Weight

Weight	1.2 kg (2 pounds, 9 ounces)
---------------	-----------------------------

Installation

Dimensions

ACX104B without flanges mounting dimensions in millimeters (inches)

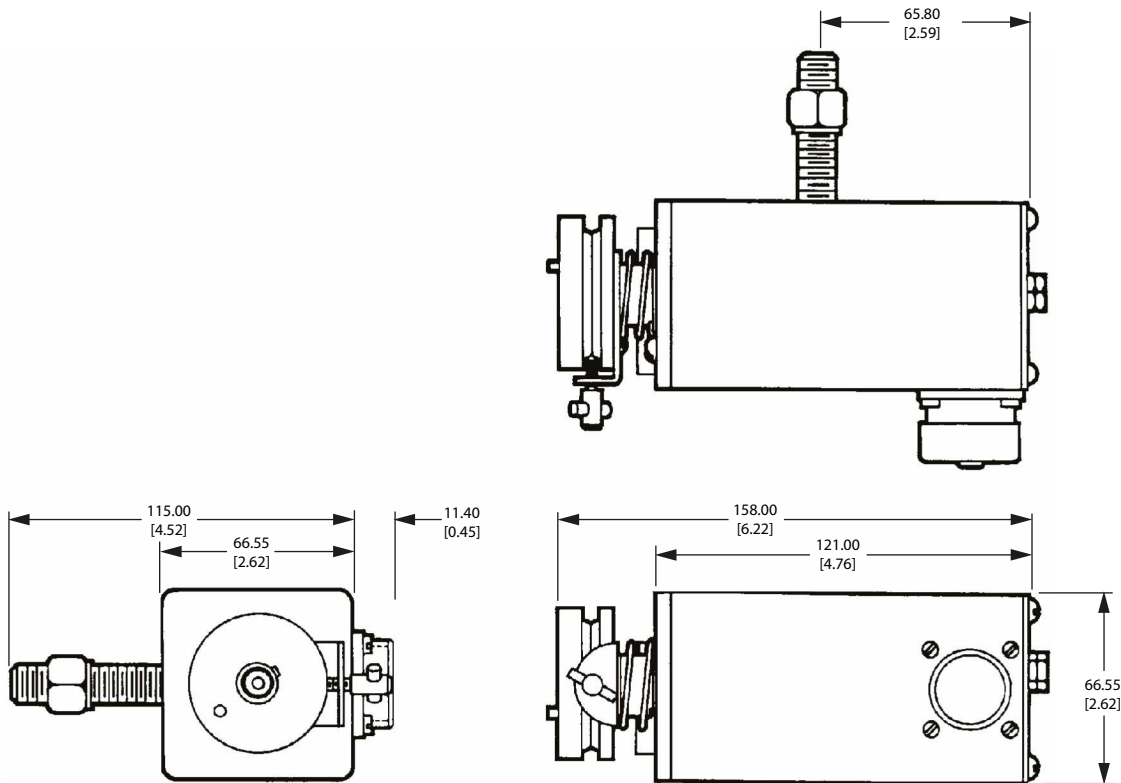

kwa1392492090507

Location

The ACX104B may be mounted on either the left or right side of the machine with the hub and follower outward. A mounting stud extends from the back of the case. It must be inserted through a vertical plate that is attached to an appropriate height-adjusting jack. The mounting stud is approximately 107.95 mm (4.25 in) above the stringline when trailing a grid of 45° below horizontal.

Mounting

The 12.7 mm (0.5 in) bolt extending from the case is a rotatable mounting, allowing for proper leveling. It is important that the ACX104B be level in the plane of rotation around this pivot. In grade application, an improper mounting will cause the follower attachment to move up or down on a level surface as the machine moves closer or farther from the stringline. Use a Right Angle Follower (KG04001), skate assembly (KG06001), ski assembly (KG02001) or steering follower (KG07001) for contact to the reference surface.

Installation

Wiring

Direct connections are made through a Bendix MS3102A- 14S-6P (K04183) box receptacle on the case exterior.

1. Connect a 134019ACAA (KW01009) cable to this receptacle.
2. Terminate the other end of the cable with an MS3102A-14S-6P (K04183) bulkhead connector.
3. Wire the bulkhead connector directly to the controller.

Reference the following representative connection diagrams:

Representative proportional rotary position control

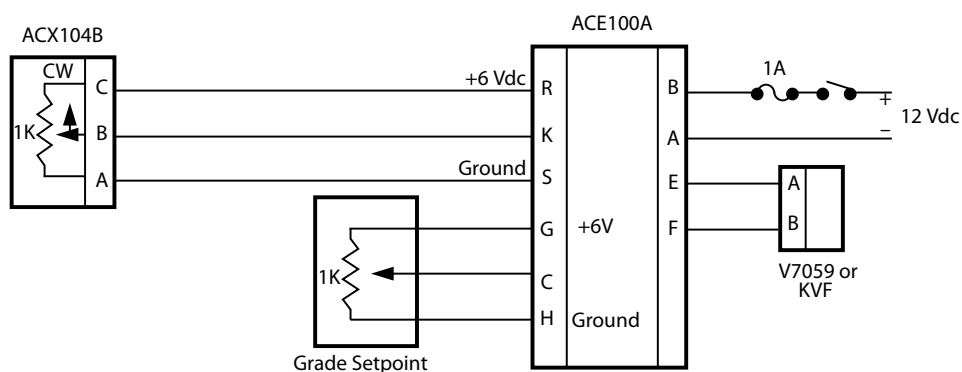

kwa1392492096923

Representative proportional steering control

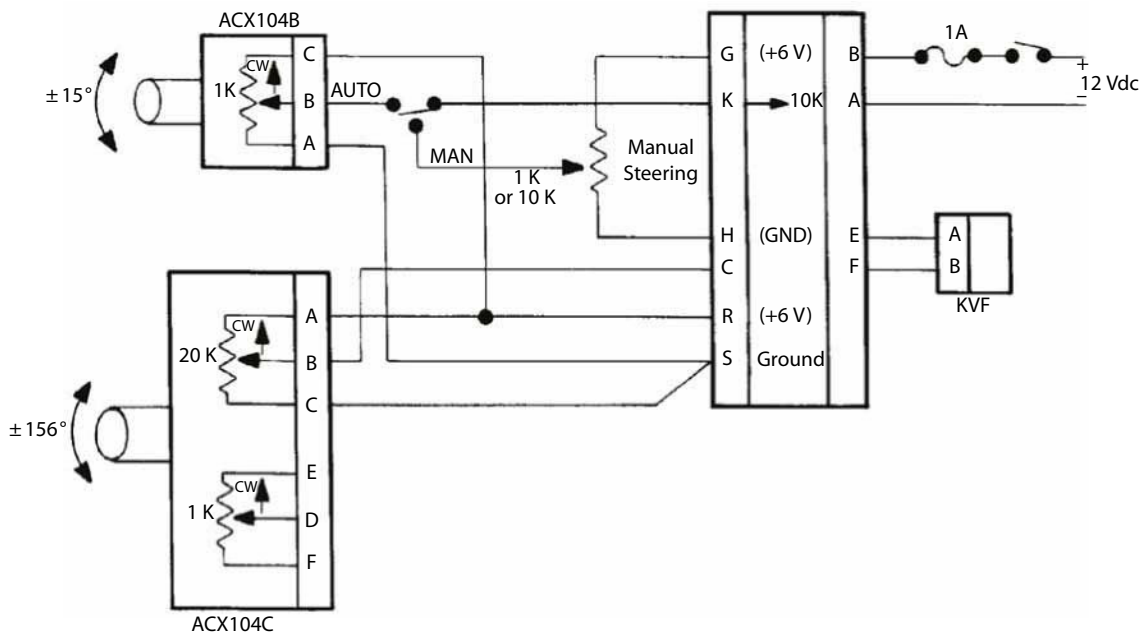

kwa1392492105355

Installation

Representative other wiring considerations (simple schematic)

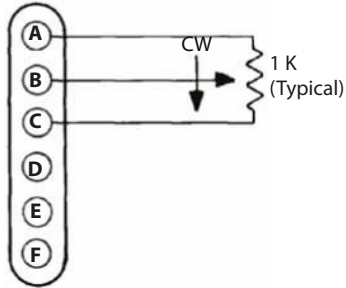

kwa1392492109606



Products we offer:

- Bent Axis Motors
- Closed Circuit Axial Piston Pumps and Motors
- Displays
- Electrohydraulic Power Steering
- Electrohydraulics
- Hydraulic Power Steering
- Integrated Systems
- Joysticks and Control Handles
- Microcontrollers and Software
- Open Circuit Axial Piston Pumps
- Orbital Motors
- PLUS+1® GUIDE
- Proportional Valves
- Sensors
- Steering
- Transit Mixer Drives

Danfoss Power Solutions is a global manufacturer and supplier of high-quality hydraulic and electronic components. We specialize in providing state-of-the-art technology and solutions that excel in the harsh operating conditions of the mobile off-highway market. Building on our extensive applications expertise, we work closely with our customers to ensure exceptional performance for a broad range of off-highway vehicles.

We help OEMs around the world speed up system development, reduce costs and bring vehicles to market faster.

Danfoss – Your Strongest Partner in Mobile Hydraulics.

Go to www.powersolutions.danfoss.com for further product information.

Wherever off-highway vehicles are at work, so is Danfoss. We offer expert worldwide support for our customers, ensuring the best possible solutions for outstanding performance. And with an extensive network of Global Service Partners, we also provide comprehensive global service for all of our components.

Please contact the Danfoss Power Solution representative nearest you.

Comatrol

www.comatrol.com

Schwarzmueller-Inverter

www.schwarzmueller-inverter.com

Turolla

www.turollaocg.com

Hydro-Gear

www.hydro-gear.com

Daikin-Sauer-Danfoss

www.daikin-sauer-danfoss.com

Local address:

Danfoss Power Solutions (US) Company
2800 East 13th Street
Ames, IA 50010, USA
Phone: +1 515 239 6000

Danfoss Power Solutions GmbH & Co. OHG
Krokamp 35
D-24539 Neumünster, Germany
Phone: +49 4321 871 0

Danfoss Power Solutions ApS
Nordborgvej 81
DK-6430 Nordborg, Denmark
Phone: +45 7488 2222

Danfoss Power Solutions Trading (Shanghai) Co., Ltd.
Building #22, No. 1000 Jin Hai Rd
Jin Qiao, Pudong New District
Shanghai, China 201206
Phone: +86 21 3418 5200

Danfoss can accept no responsibility for possible errors in catalogues, brochures and other printed material. Danfoss reserves the right to alter its products without notice. This also applies to products already on order provided that such alterations can be made without changes being necessary in specifications already agreed. All trademarks in this material are property of the respective companies. Danfoss and the Danfoss logotype are trademarks of Danfoss A/S. All rights reserved.