

MAKING MODERN LIVING POSSIBLE

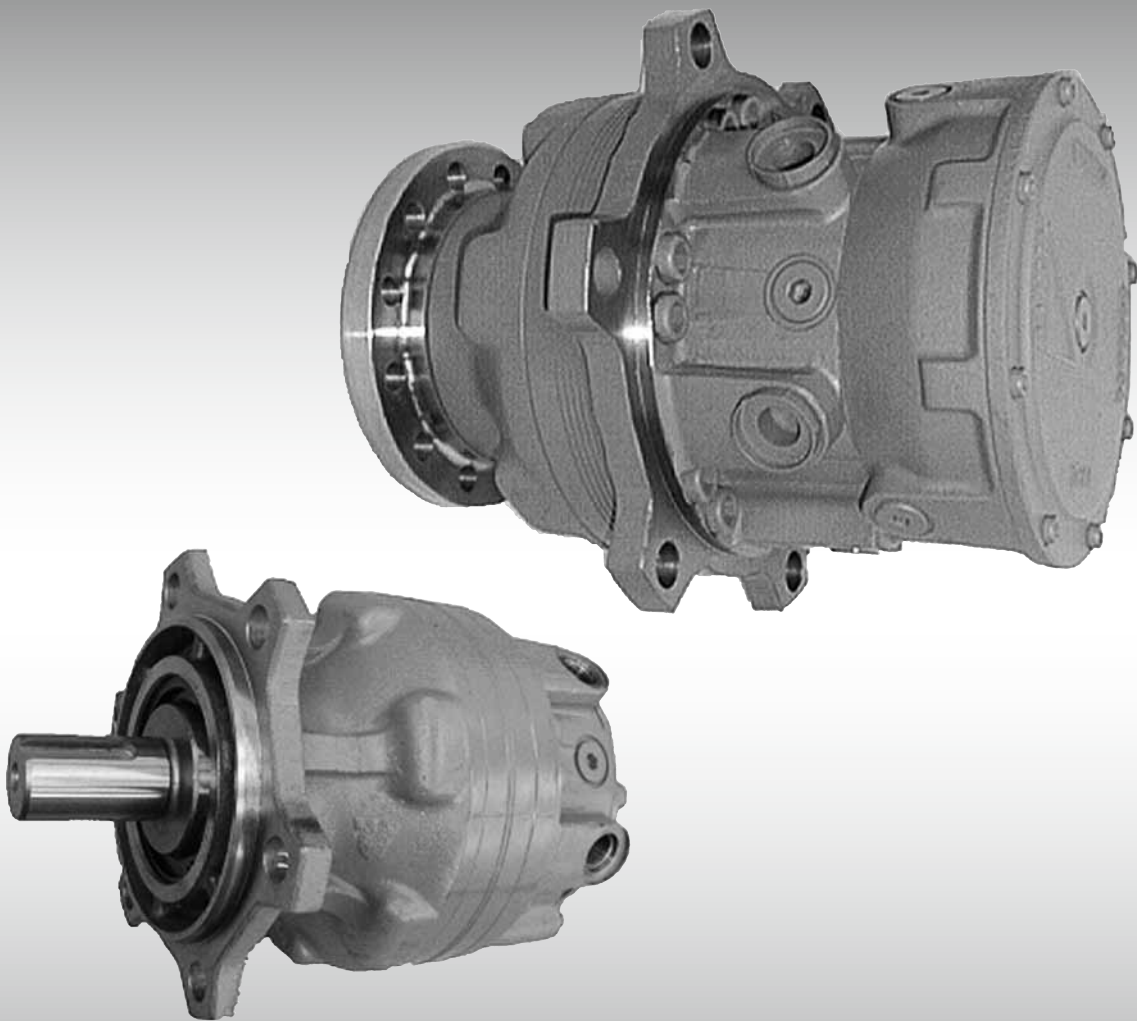

Technical Information
Series DCM
Cam Motor



Technical Information Series DCM Cam Motor

Content

Overview	For safe use of hydraulic units	3
	Notes for cam usage.....	4
	Model code.....	6
Technical Data	Overview	7
	Features	7
	Descriptions for the hydraulic system	8
	Specifications.....	10
	DCM0280	10
	DCM0560	11
Optional Specifications	2-speed shift.....	12
	Parking brake.....	13
	Flushing valve.....	14
	Minimum charge pressure settings.....	14
System Design Parameter	Freewheel drive.....	15
	Allowable external load (center flange type).....	16
	Allowable external load (front flange type).....	17
	Allowable external load (face mounting type).....	18
Dimensions	Center flange type	19
	Front flange type (without brakes)	20
	Face mounting type (with brakes)	21
	Brakes	22
Notes for Hydraulic Unit Use	Notes for fluid use	23
	Notes for hydraulic motor use	23

Technical Information Series DCM Cam Motor

Overview

For safe use of hydraulic units

- Read carefully “Notes for Cam Motor Usage” and “Notes for Hydraulic Unit Use” for proper use.
- Notes are classified into three categories below. Be sure to follow those instructions as they are important for your safety.



Danger

Mishandling may induce impending dangerous situations that could result in death or serious injury.



Warning

Mishandling may induce fatal or serious injury.



Caution

Mishandling may induce physical or material damage.

Be sure to follow these instructions above, which are important for your safety. It will help you to avoid disastrous accidents that might result in injury.

Technical Information Series DCM Cam Motor

Overview

Notes for Cam Motor Usage

These are the instructions that you should pay attention on cam motor usage. Read thoroughly this Notes together with the Notes for Hydraulic Unit Use at the end of this Technical Information and use the product properly.

Fluid pollution

⚠Caution

Fluid pollution limit should be within NAS 9.

Motor installation, air vent

⚠Caution

Install the cam motor with the drain port upward or raise drain piping higher than the cam motor so as to constantly fill fluids in the casing.

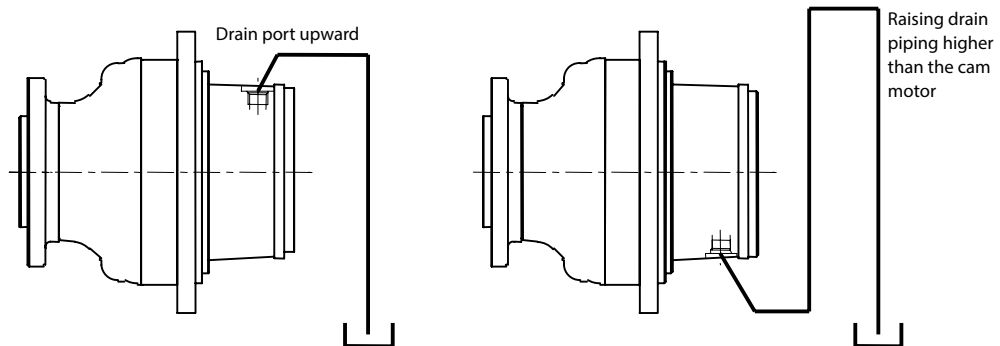

⚠Caution

For cam motor with brake, loosen the mechanical brake release plug for air vent at start-up so as to fill the brake with the fluid.

Brake release plug

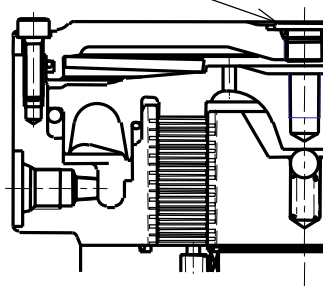

Charge pressure

⚠Caution

Insufficient charge pressure causes the roller, which should move in contact with the cam ring, to be loosened and intermittently tap the cam ring. As it significantly impairs cam motor life, keep the value mentioned on page 14 at minimum for the charge pressure.

Brake

⚠Warning

Cam motor brake should be used for parking. Using as a dynamic brake may cause cam motor brake disk lining wear, resulting in brake torque drop.

Technical Information Series DCM Cam Motor

Overview

Notes for Cam Motor Usage (continued)

Tow

Caution

When towing the machine due to failure, short circuit the high-pressure work line and low-pressure work line of the main circuit, manually conduct mechanical brake release (see p.13), then tow.

Tow no farther than 30m in 10rpm.

Long-distance tow may damage HST pump and cam motor. It is therefore recommended to pull over to the nearest shoulder of the road.

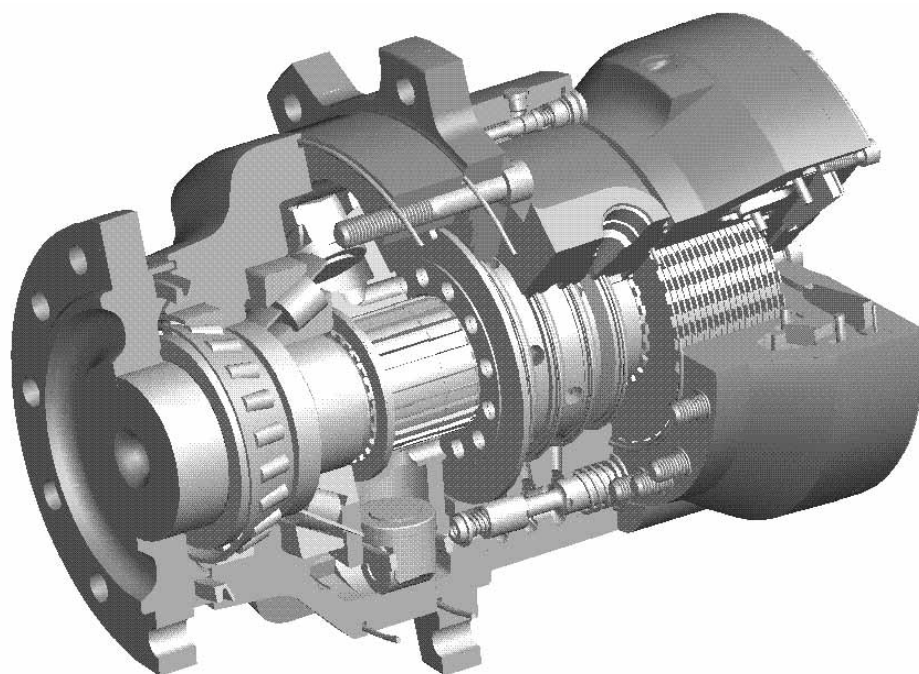

Technical Information Series DCM Cam Motor

Overview

Model code

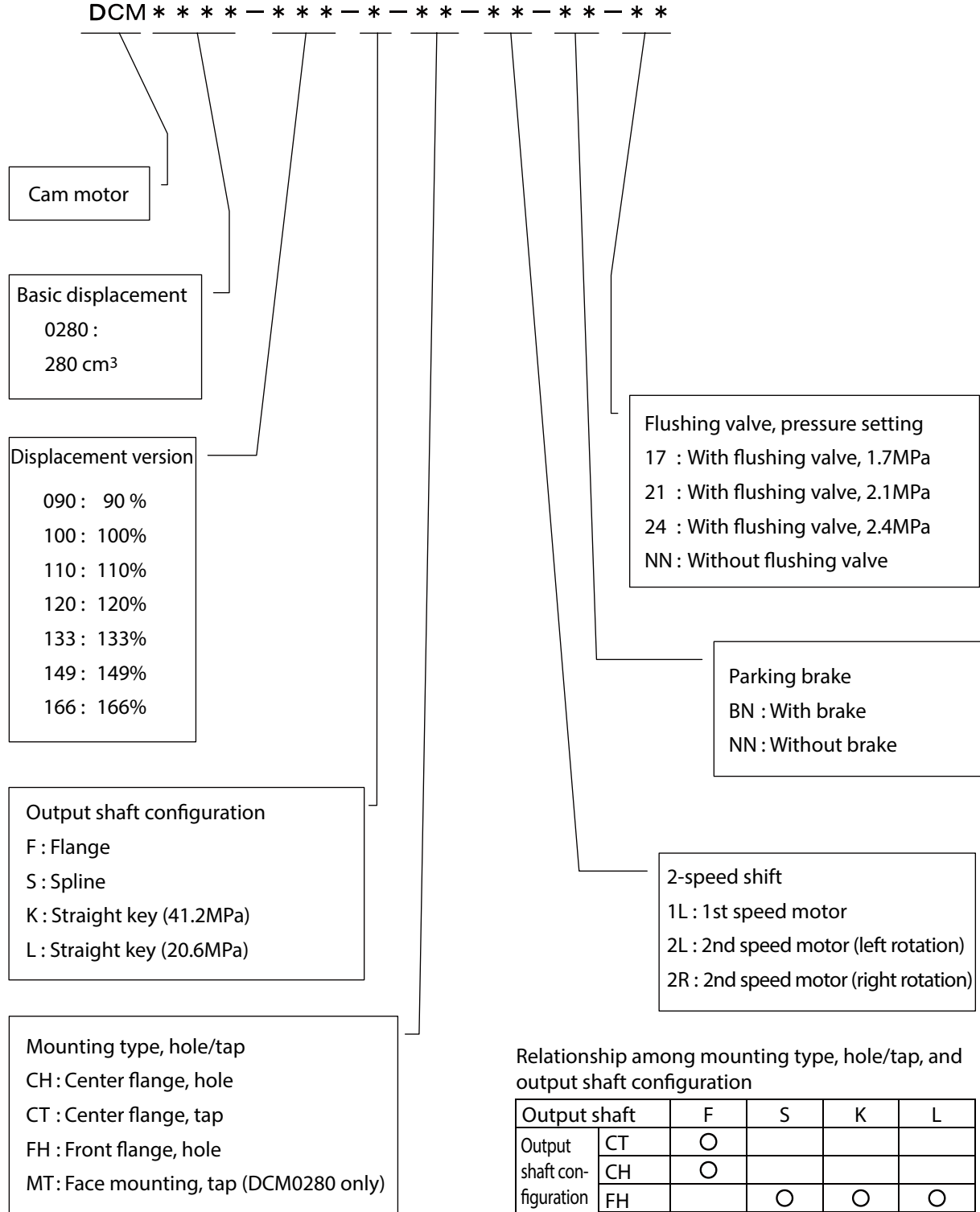

Technical Information Series DCM Cam Motor

Technical Data

Overview

Series DCM Cam Motor is a multistroke radial piston motor, in which eight pistons radially mounted in a cylinder block run for 6-thread cam rings.

A hydraulic circuit matching a hydraulic pump converts hydraulic pressure produced at the pump into running torque.

The simple mechanism, which enables to produce high needs no gearbox and keeps mechanical efficiency in high level.

A wheel-drive output shaft secures high capability for external load.

As the cam is designed to produce consistent output torque, it avoids speed error even in low speed while produces high start-up torque.

A flat distributor designed as the most suitable hydraulic balance and pistons equipped with piston-rings result in the least leakage.

Optional parts such as 2-speed shift, parking brake, and flashing valve, are available for all the products in the all series.

Features

- High allowable radial load
Large shaft diameter and high tapered roller bearing capacity give the most allowable external load in this class.
- Wider choice for displacement ratio
Available displacement ratio is 90% to 166% of basic displacement with the same external diameter.
- Improvement in limited horsepower
Increases roller size for longer life and more durability.
More temperature-resistant journal bearing is used in the piston.
- More reliable brakes
For safety, brake torque is 130% of maximum output torque.
Highly abrasion-resistant paper lining
- Improved sealing ability
Equipped with high-pressure oil seals combining lip seals and retainers, tolerant of case surge pressure of 1MPa (10kgf/cm²) at maximum.
Dust seals preventing mud inflow is sufficiently durable even under a hostile environment.
A face-mounting model is equipped with more resistant heavy-duty dust seals used for agricultural machinery.

Technical Information Series DCM Cam Motor

Technical Data

Descriptions for the hydraulic system

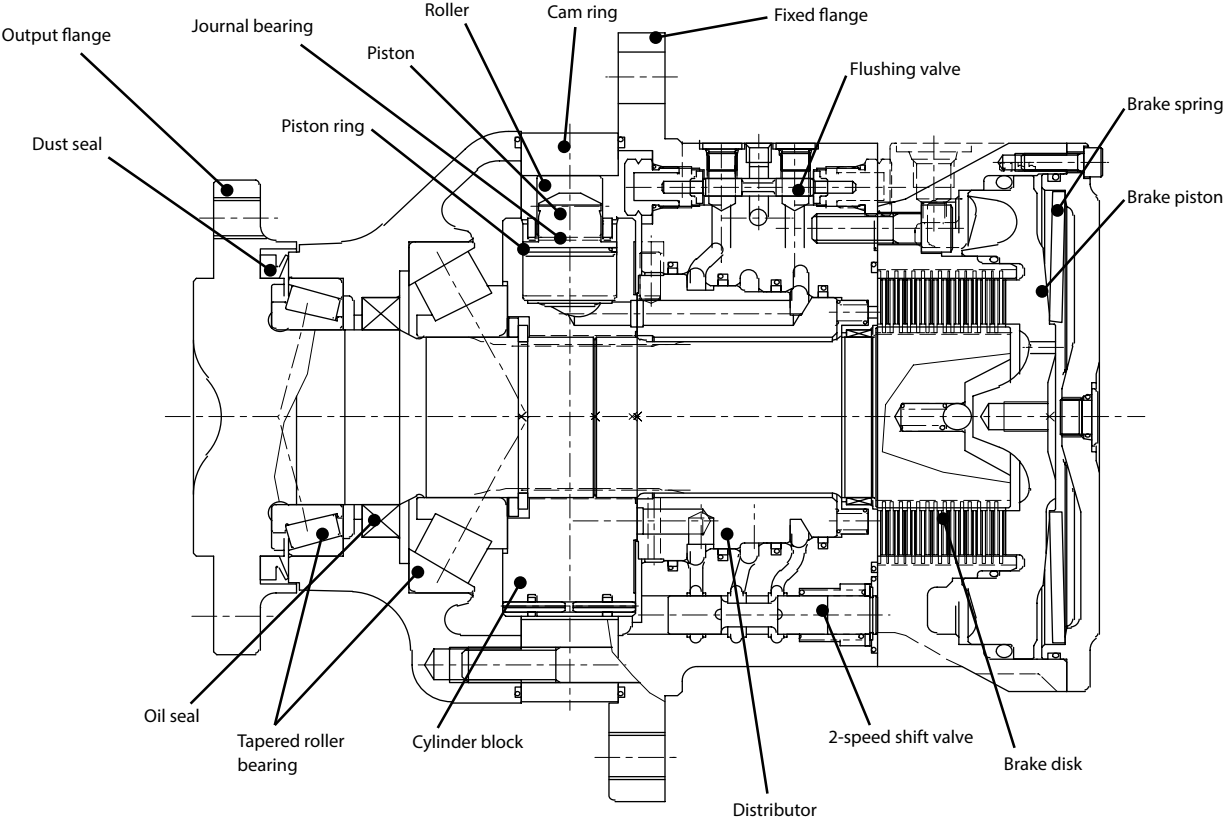

Fig.1 DCM series descriptions

Technical Information Series DCM Cam Motor

Technical Data

Descriptions for the hydraulic system (continued)

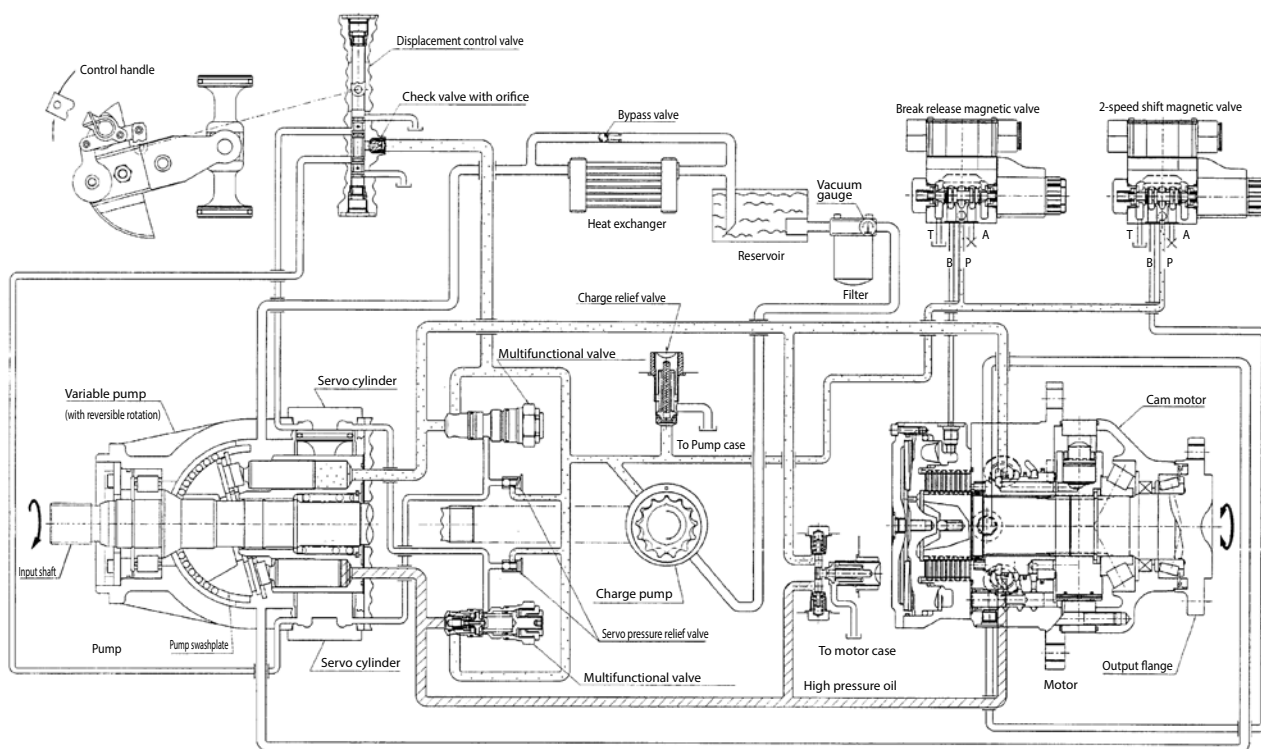

Fig.2 Hydraulic Circuit Schematic

The circuit above shows the application of the 90 series axial piston pump and cam motor.

Technical Information Series DCM Cam Motor

Technical Data

Specification

Table of DCM0280

		DCM0280							
Displacement (version)	%	90	100	110	120	133	149	166	
Full displacement	cm ³	252	280	308	336	372	417	465	
Half displacement		126	140	154	168	186	209	232	
Fixed differential pressure ΔP	MPa	41.2 (420)				34.3 (350)			*1
Maximum port pressure	(kgf/cm ²)	44.6 (455)				37.8 (385)			*2
Maximum surge pressure		48.1 (490)				41.2 (420)			*2
Maximum output speed	min ⁻¹	260				220			*3
Minimum continuous speed	min ⁻¹	5 ~ 10 {dependent on application}							*4
Maximum output torque	N-m (kgf-m)	1650 (168)	1830 (187)	2020 (206)	2210 (225)	2030 (207)	2280 (232)	2540 (259)	*5
Limit horsepower	kW (HP)	29 (39)				32 (43)			*6
Full displacement		15 (20)				16 (21)			
Half displacement									
Allowable radial load on output shaft	N (kgf)	56900 (5800)							
Parking brake									
Release pressure	MPa (kgf/cm ²)	1.5 {min.} ~ 4.9 {max.} (15 ~ 50)							
Holding torque	N-m (kgf-m)	3370 (344)							
Pilot pressure for 2-speed shift	MPa								
Full displacement	(kgf/cm ²)	0.2 or less (2 or less)							
Half displacement		1.0 {min.} ~ 4.9 {max.} (10 ~ 50)							
Setting pressure of flushing valve	MPa (kgf/cm ²)	1.7 2.1 2.4 (17 21 24)							
Case drain pressure	MPa								
Continuous	(kgf/cm ²)	0.3 (3)							
Intermittent(surge)		1 (10)							
Hydraulic fluid	mm ² /s	Abrasion resistant fluid							
Recommended viscosity	(cst)	13.0							
Minimum viscosity		6.3 (continuous) / 5.0 (max. 5 minutes)							
Maximum viscosity		110 (continuous) / 1600 (starting at low temperature)							
Hydraulic fluid temperature range (inside case)	°C	-20 ~ 104 (max. 5 minutes 115°C)							
Weight with brake	kg	39							
without brake	kg	29							

*1 This value means the maximum setting pressure (differential pressure) of main pressure relief valve.

*2 These values mean 'absolute' pressure. (Not differential pressure)

'Maximum surge pressure' that means the maximum value of surge pressure may occur within one second only for each operation, and accumulated number is within 500,000 times.

*3 Vehicle overrun speed such as downhill must be within 'maximum output speed'.

*4 Using under 5 rpm speed, please contact Danfoss representative.

*5 'Maximum output torque' means the theoretical value at full displacement of fixed differential pressure.

*6 The operation of maximum limit horsepower may occur within accumulated 30 hours.

Technical Information Series DCM Cam Motor

Technical Data

Specification (continued)

Table of DCM0560

		DCM0560							
Displacement (version)	%	90	100	110	120	133	149	166	
Full displacement	cm ³	504	560	616	672	745	834	930	
Half displacement		252	280	308	336	372	417	465	
Fixed differential pressure ΔP	MPa	41.2 (420)				34.3 (350)			*1
Maximum port pressure	(kgf/cm ²)	44.6 (455)				37.8 (385)			*2
Maximum surge pressure		48.1 (490)				41.2 (420)			*2
Maximum output speed	min ⁻¹	200				170			*3
Minimum continuous speed	min ⁻¹	5 ~ 10 {dependent on application}							*4
Maximum output torque	N-m (kgf-m)	3300 (337)	3670 (374)	4040 (412)	4400 (449)	4070 (415)	4560 (465)	5080 (518)	*5
Limit horsepower	kW (HP)	46 (62)				52 (70)			*6
Full displacement		23 (31)				26 (35)			
Allowable radial load on output shaft	N (kgf)	65700 (6700)							
Parking brake									
Release pressure	MPa (kgf/cm ²)	1.5 {min.} ~ 4.9 {max.} (15 ~ 50)							
Holding torque	N-m (kgf-m)	6550 (668)							
Pilot pressure for 2-speed shift	MPa								
Full displacement	(kgf/cm ²)	0.2 or less (2 or less)							
Half displacement		1.0 {min.} ~ 4.9 {max.} (10 ~ 50)							
Setting pressure of flushing valve	MPa (kgf/cm ²)	1.7 2.1 2.4 (17 21 24)							
Case drain pressure	MPa								
Continuous	(kgf/cm ²)	0.3 (3)							
Intermittent (surge)		1 (10)							
Hydraulic fluid	mm ² /s	Abrasion resistant fluid							
Recommended viscosity	(cst)	13.0							
Minimum viscosity		6.3 (continuous) / 5.0 (max. 5 minutes)							
Maximum viscosity		110 (continuous) / 1600 (starting at low temperature)							
Hydraulic fluid temperature range (inside case)	°C	-20 ~ 104 (max. 5 minutes 115°C)							
Weight with brake	kg	70							
without brake	kg	52							

*1 This value means the maximum setting pressure (differential pressure) of main pressure relief valve.

*2 These values mean 'absolute' pressure. (Not differential pressure)

'Maximum surge pressure' that means the maximum value of surge pressure may occur within one second only for each operation, and accumulated number is within 500,000 times.

*3 Vehicle overrun speed such as downhill must be within 'maximum output speed'.

*4 Using under 5 rpm speed, please contact Danfoss representative.

*5 'Maximum output torque' means the theoretical value at full displacement of fixed differential pressure.

*6 The operation of maximum limit horsepower may occur within accumulated 30 hours.

Technical Information Series DCM Cam Motor

Optional Specifications

2-speed shift

2-speed shift is available for all the series DCM products.

When the 2-speed shift port pressure is 0.2MPa (2kgf/cm²) or less, oil flows into six distributor ports from the pump in maximum quantity (in full displacement).

When the port pressure is between 1.0 and 4.9MPa (10-50kgf/cm²), oil flows into three distributor ports from the pump in minimal quantity (in half displacement).

Shift action should be conducted when the motor is off. Shift during motor running may deteriorate motor life due to sudden pressure fluctuation.

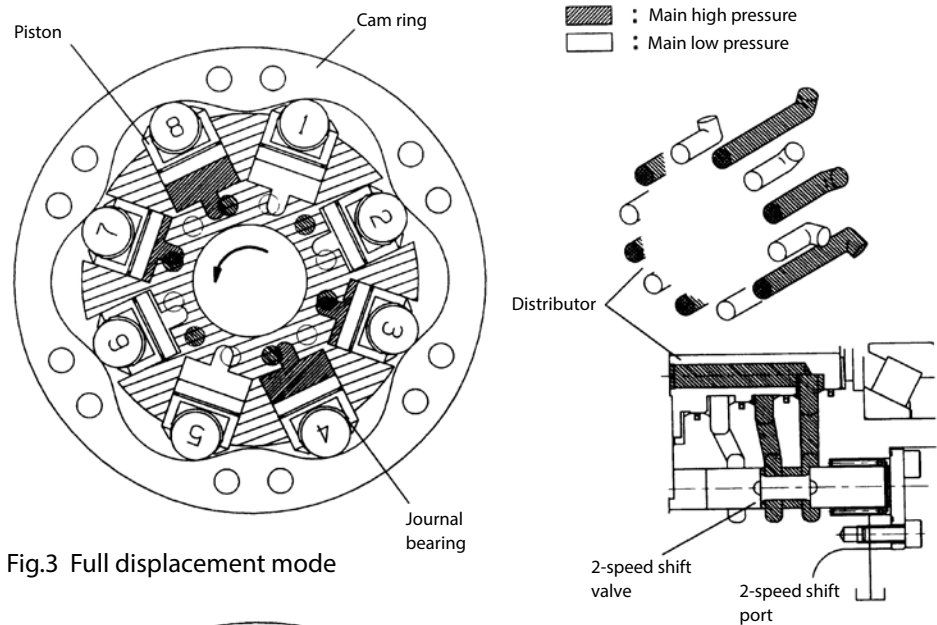

Fig.3 Full displacement mode

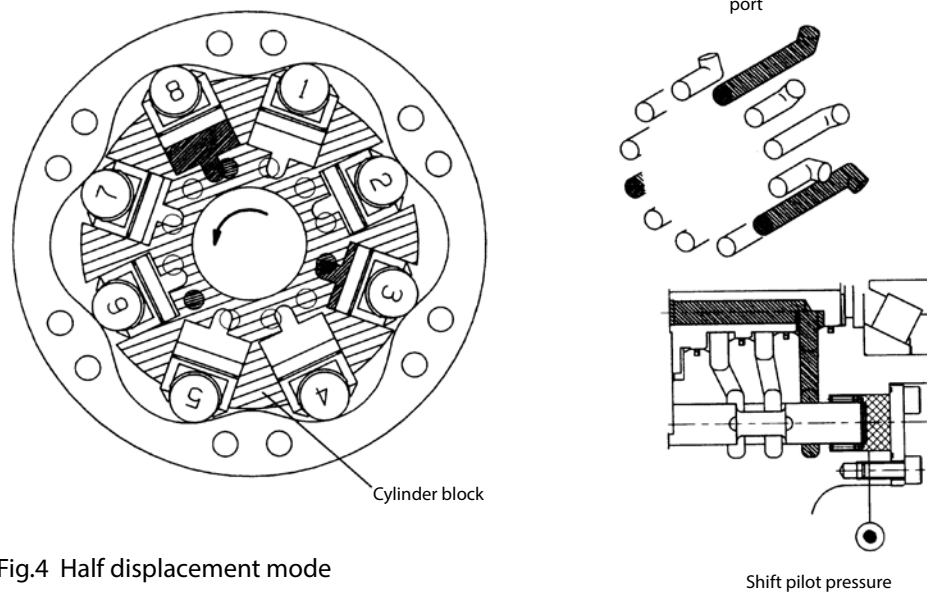

Fig.4 Half displacement mode

⚠ Caution

The 2-speed motor has different efficiency in half displacement depending on rotating direction. Two models for left or right rotation are available. Please specify the direction you use more often.

Technical Information Series DCM Cam Motor

Optional Specifications

Parking brake

The multi-disk parking brake for the series DCM consists of multiple friction plates and separate plates.

Without release pressure, the brake spring presses the brake disk the brake piston to apply the brake.

The brake is released by release pressure of 1.5 - 4.9 MPa (15-50 kgf/cm²).

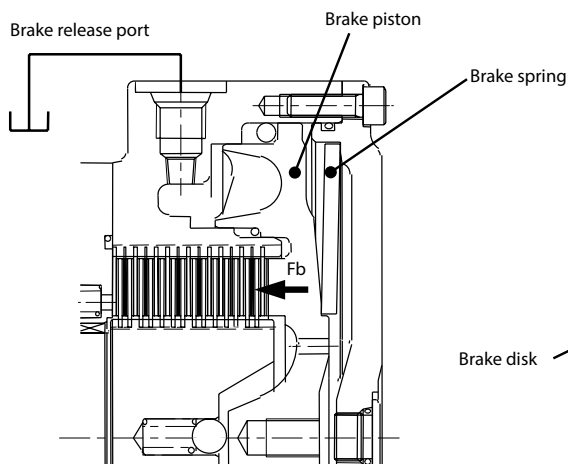

Fig. 5 When brake is applied

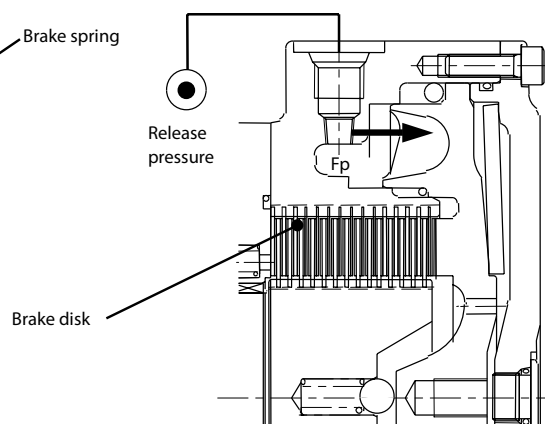

Fig. 6 When brake is released

For insufficient brake release pressure, the brake can be released mechanically.

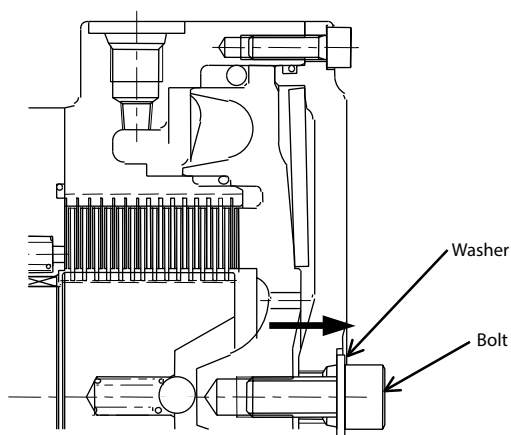

Fig.7 Mechanical brake release

	DCM0280	DCM0560
Bolt	M10×25L (coarse pitch)	M12×30L (coarse pitch)
High-tension washer	For M10	For M12
Outer diameter	19~23	22~27
Thickness	2.5~3.5	2.5~3.5

Technical Information Series DCM Cam Motor

Optional Specifications

Flushing valve

Flushing valve can contain loop flushing valve to cool main circuits and remove contaminations.

[At neutral]

[During operation]

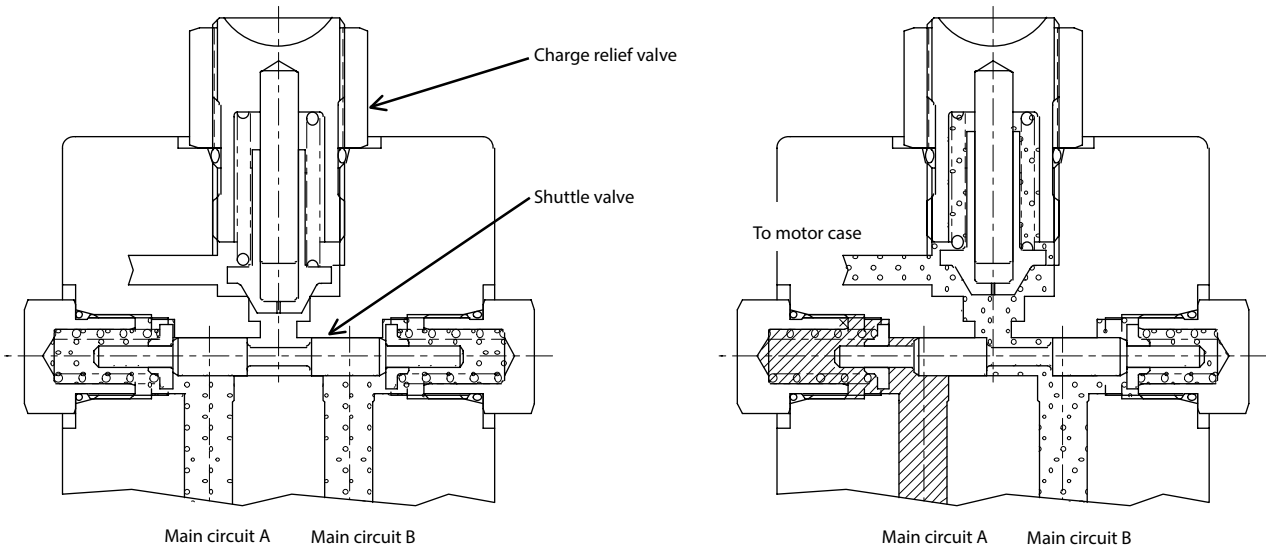

Fig.8 Loop flushing valve

Minimum charge pressure settings

Keep the main circuit minimum pressure at the pressure shown in the figure below or higher.

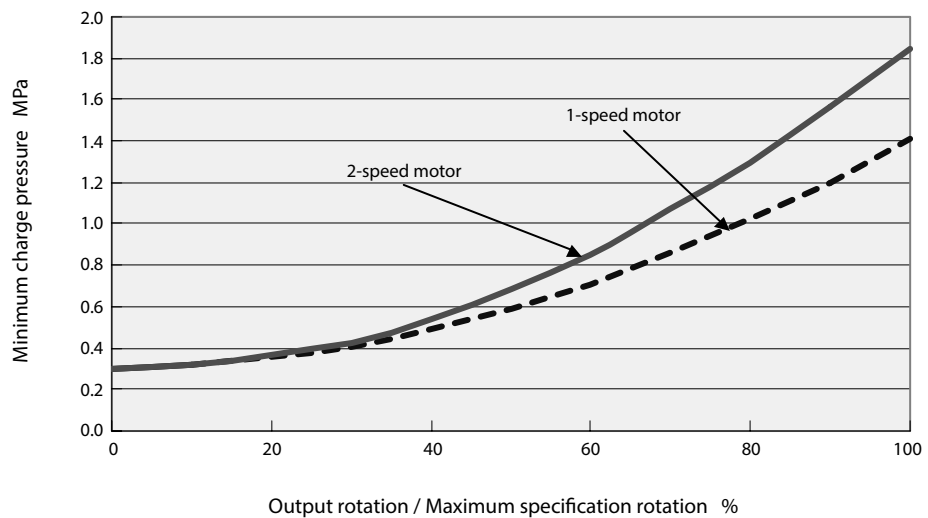

Fig.9 Minimum charge pressure settings

Technical Information Series DCM Cam Motor

Optional Specifications

Freewheel drive

The motors in the series DCM enable freewheel drive without any loss. For the open circuit configuration, see the figure below (Fig.11).

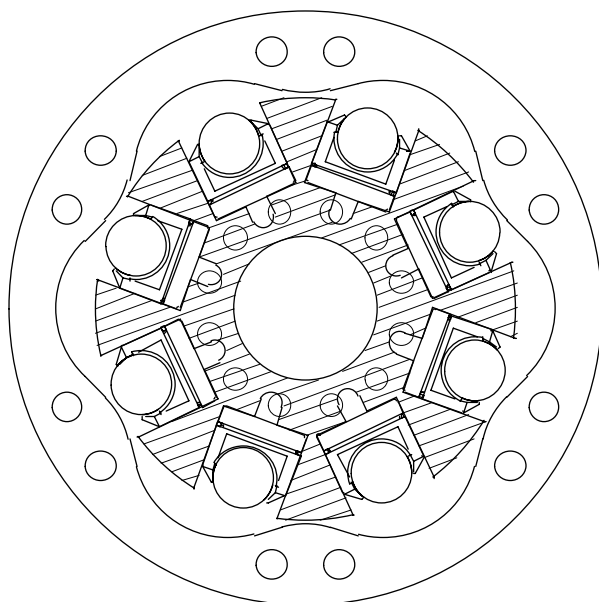

Fig. 10 Freewheel mode

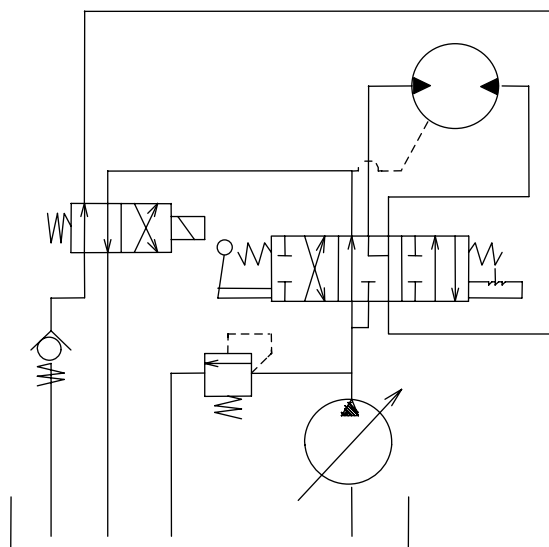

Fig.11 Freewheel circuit configuration sample

- Continuity should be secured from a motor main port to a tank.
- Low pressure on the motor drain port pushes the piston toward the center of the cylinder block. The piston thus moves from the cam ring.
- Set the motor case pressure 0.15MPa (1.5kgf/cm²) higher than main port pressure.

Maximum output speed

Series	DCM0280	DCM0560
Maximum output speed min ⁻¹	600	480

Technical Information Series DCM Cam Motor

System Design Parameter

Allowable external load (Center flange type)

The figure below shows the relationship between allowable radial load and total bearing rotation number for the center flange type at the constant thrust load of 10000N (1020kgf).

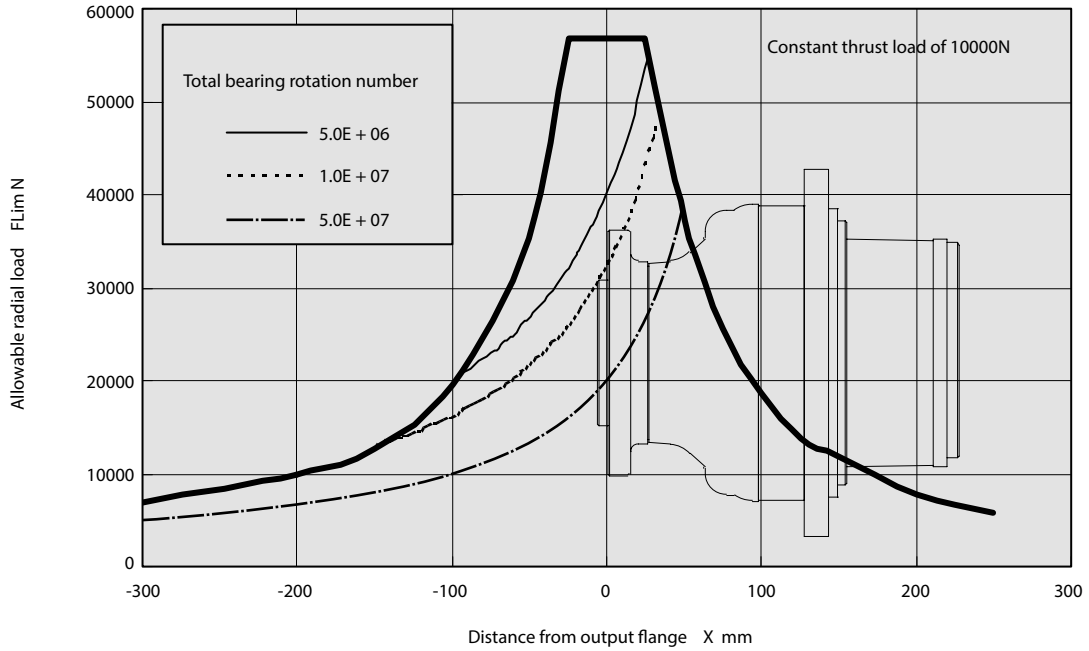

Fig.12 DCM0280 allowable radial load for the center flange type

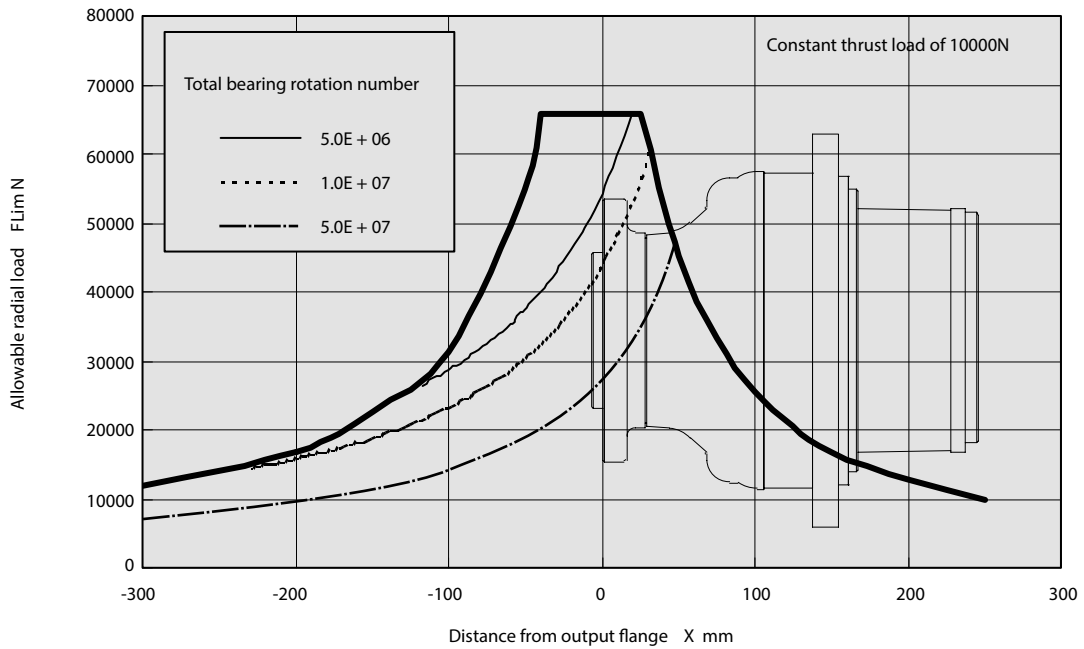

Fig.13 DCM0560 allowable radial load for the center flange type

Technical Information Series DCM Cam Motor

System Design Parameter

Allowable external load (Front flange type)

The figure below shows total bearing rotation number for the front flange type at the constant thrust load of 10000N (1020kgf).
For the radial load of the 20.6MPa shaft, see p.20.

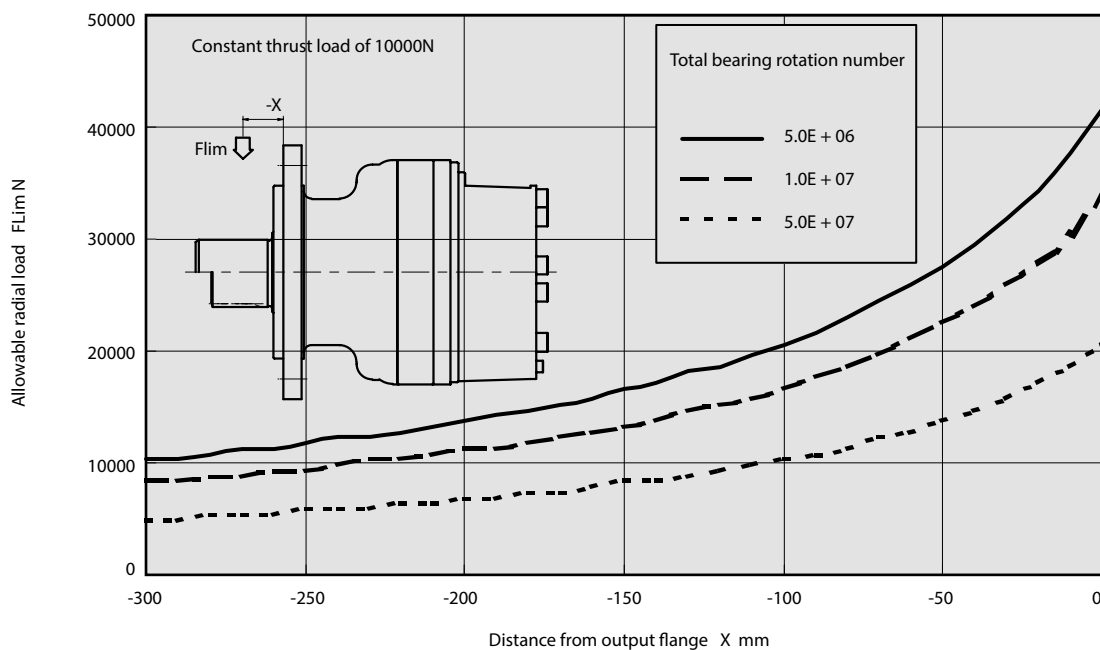

Fig.14 DCM0280 allowable radial load for the front flange type

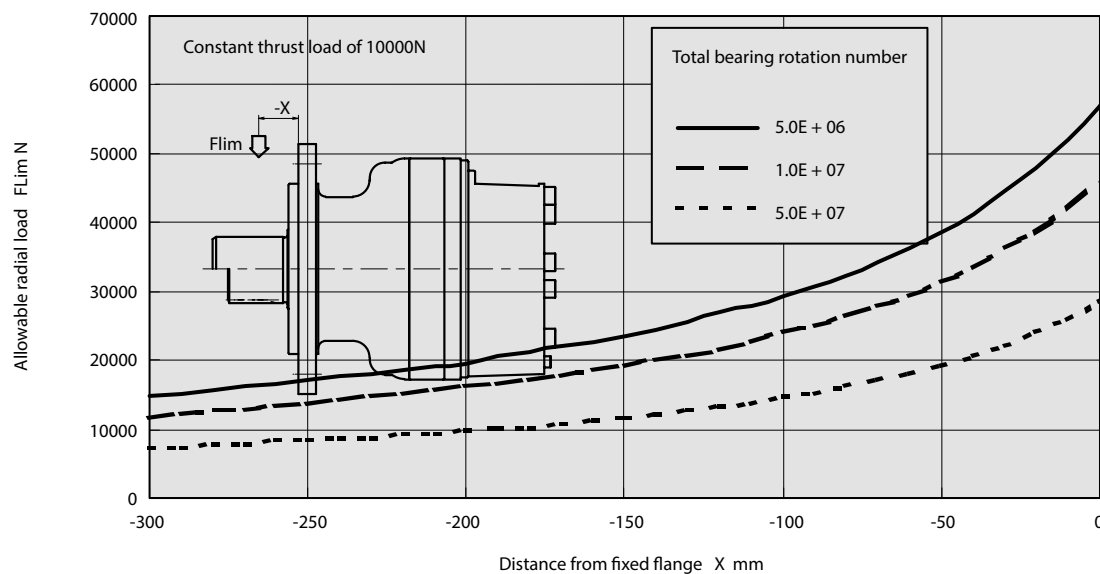

Fig.15 DCM0560 allowable radial load for the front flange type

Technical Information Series DCM Cam Motor

System Design Parameter

Allowable external load (Face mounting type)

The figure below shows total bearing rotation number for the face mounting type at the constant thrust load of 10000N (1020kgf).

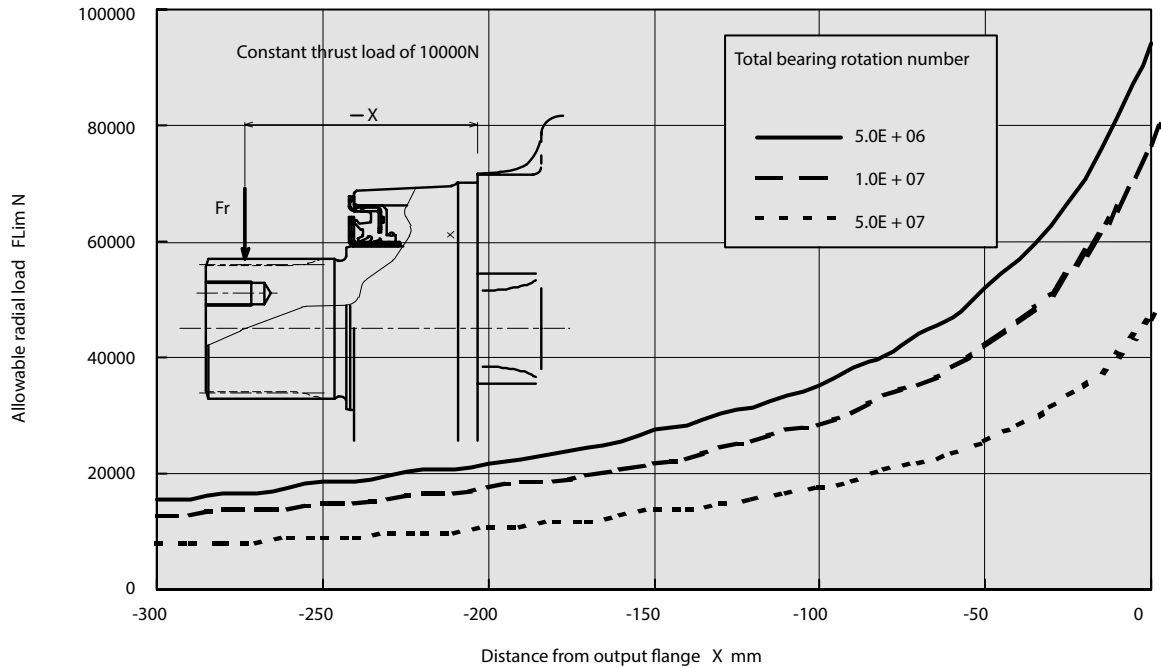

Fig.16 DCM0280 allowable radial load for the face mounting type

Technical Information Series DCM Cam Motor

Dimensions

Center flange type <CH/CT>

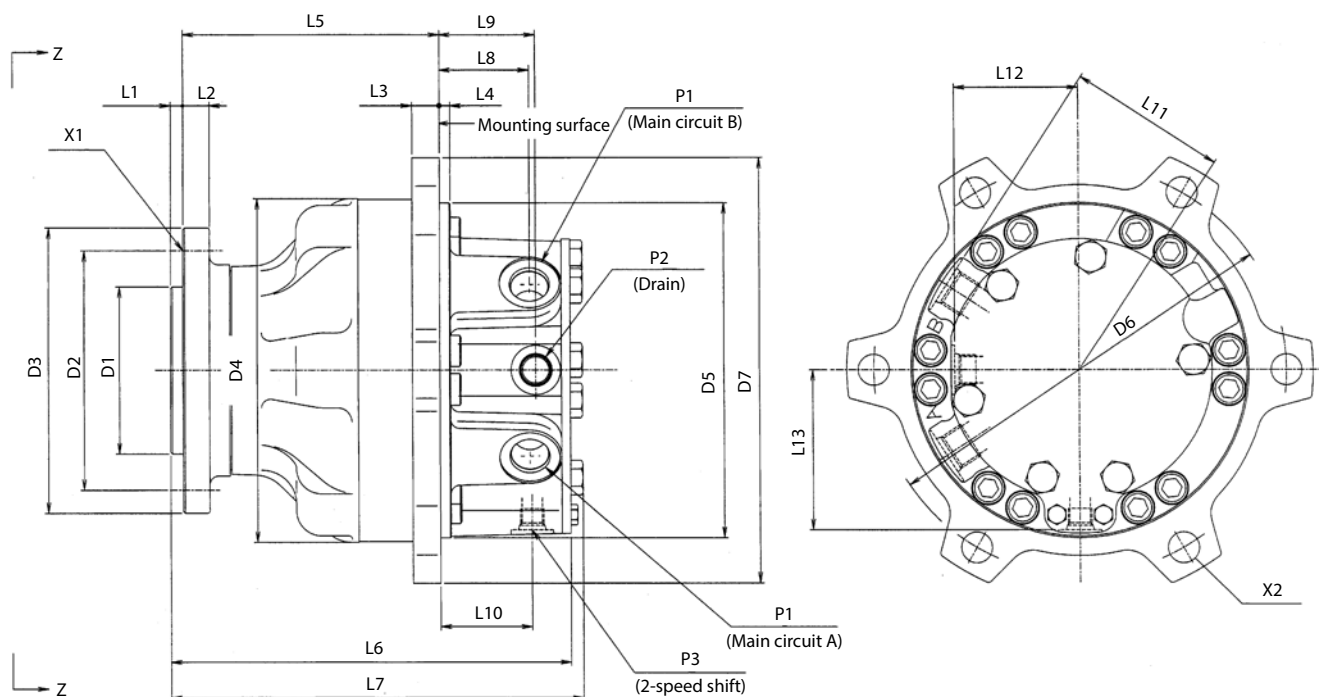

Fig. 17 Dimensions for a center flange type unit (without brakes)

	D1	D2	D3	D4	D5	D6	D7
DCM0280	95 h7	136	162	195	190 h8	232	262
DCM0560	120 h7	165	200	244	238 h8	280	318

	L1	L2	L3	L4	L5	L6	L7	L8
DCM0280	7	15	15.5	6	144.5	225	232	50.5
DCM0560	7	17	18	8.5	166.5	250.5	258.5	52

	L9	L10	L11	L12	L13		
DCM0280	54	51.5	89	70	90.5		
DCM0560	53	53	110	90.5	111		

	Output flange mounting X1	Fixed flange mounting X2		Main port P1	Drain port P2	2-speed shift P3
		Hole <CH>	Tap <CT>			
DCM0280	12-M14	6- ϕ 17.5	6-M16	2-G1/2	G3/8	G1/4
DCM0560	9-M18	6- ϕ 20	6-M18	2-G1/2	G1/2	G1/4

<Rotation direction> from the "z-z" direction

Main circuit A	Main circuit B	Standard motor	2nd speed motor	
		Standard	For left rotation	For right rotation
Low pressure	High pressure	Left rotation	Left rotation	Right rotation
High pressure	Low pressure	Right rotation	Right rotation	Left rotation

Technical Information Series DCM Cam Motor

Dimensions

Front flange type <FH> (Without brakes)

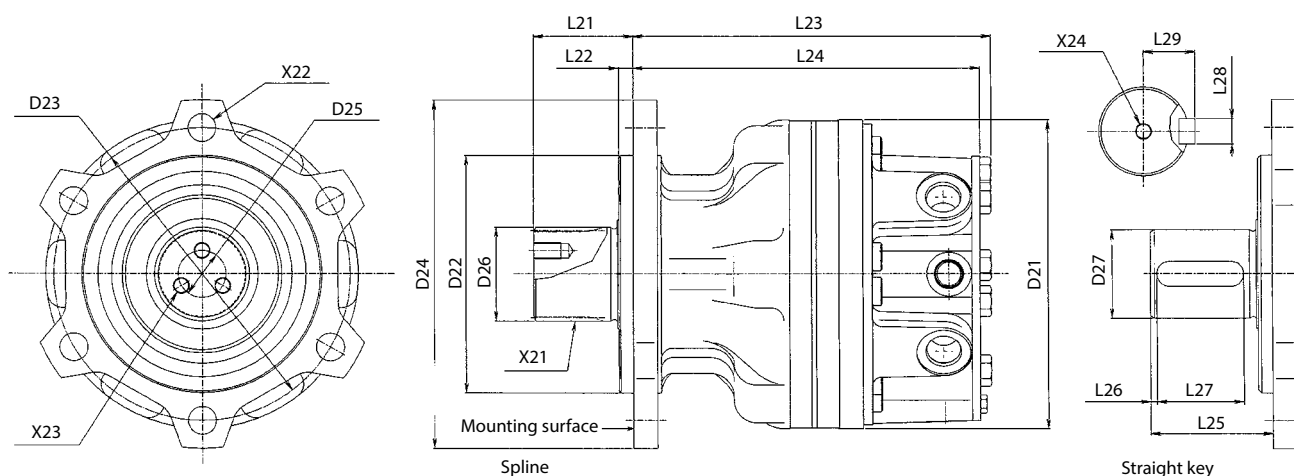

Fig. 18 Dimensions for a front flange type unit (without brakes)

	D21	D22	D23	D24	D25	D26	D27
DCM0280	195	150 h8	185	220	30	59.5 0/-0.2	56 h6
DCM0560	244	190 h8	230	270	40	72 0/-0.2	70 h6

	L21	L22	L23	L24	L25	L26	L27
DCM0280	62.5	9	224.5	217.5	76	4	54
DCM0560	63	9	246	238	93	5	70

	L28	L29	L30 (Spline effective length)
DCM0280	16 0/-0.043	32	30
DCM0560	20 0/-0.052	39.5	33

	Output shaft X21	Fixed flange mounting X22	Shaft tip tap	
			X23	X24
DCM0280	JIS D2001 60x22x2.5 class a	6- ϕ 17.5	3-M10 depth 17	1-M10 depth 17
DCM0560	JIS D2001 72.5x27x2.5 class a	6- ϕ 20	3-M12 depth 25	1-M12 depth 25

<Smaller diameter shaft for 20.6MPa>

Straight key type models can be optionally equipped with smaller diameter shafts. However, in the light of shaft strength, be sure to limit rated pressure to 20.6MPa (210kgf/cm²) and also keep radial load at the shaft end within the values shown below.

	D27	L25	L26	L27	L28	L29	Maximum radial load
DCM0280	38.1 h6	77	0	44	9.52 +0.03/0	23.35	10000 N (1020kgf)
DCM0560	57.15 h6	113	0	66.5	12.7 +0.03/0	34.345	16000 N (1630kgf)

Technical Information Series DCM Cam Motor

Dimensions

Face mounting type <MT> DCM0280 only (with brakes)

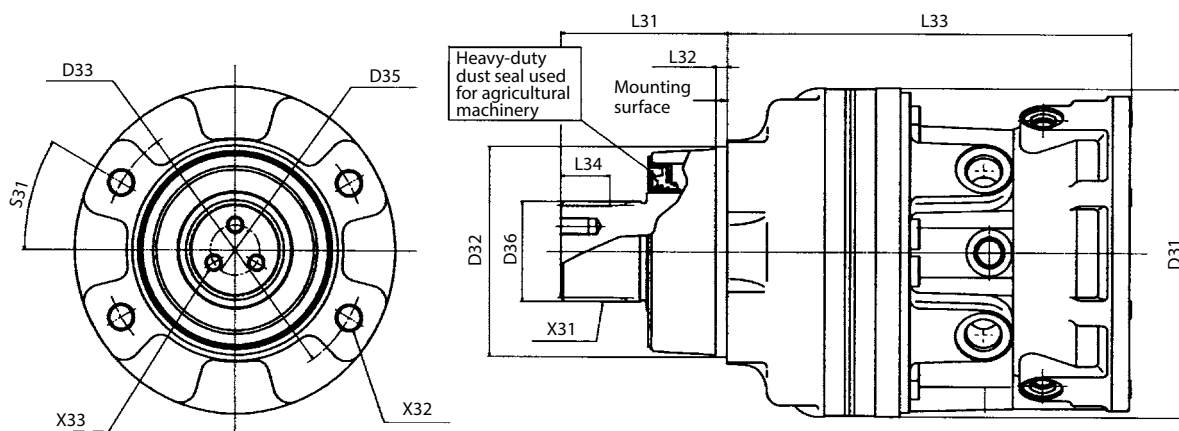

Fig. 19 Dimensions for a face mounting type unit (with brakes)

	D31	D32	D33	D35	D36
DCM0280	195	125 h8	160	30	59.5 0/-0.2

	L31	L32	L33	L34 (Spline effective length)	S31
DCM0280	101.5	7	245.5	30	30°

	Output shaft X31	Fixed flange mounting X32	Shaft tip tap X33
DCM0280	JIS D2001 60x22x2.5 class a	4-M16 depth 26	3-M10 depth 17

Face mounting type model is equipped with more dust-resistant heavy-duty dust seals used for agricultural machinery.

Technical Information Series DCM Cam Motor

Dimensions

Brakes

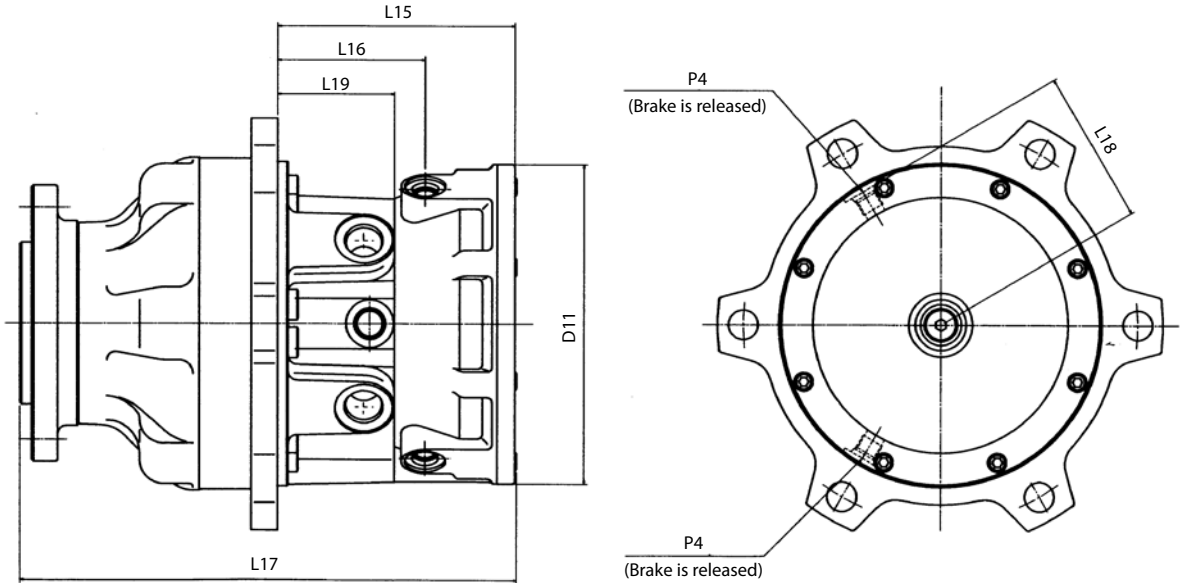

Fig.20 Brake dimensions

	D11	L15	L16	L17	L18	L19
DCM0280	187	139.5	86.5	292	90.5	68.5
DCM0560	234	156	96	331.5	114	71

	Brake release port P4
DCM0280	2-G1/4
DCM0560	2-G1/4



DCM0560
Front flange type



DCM0280
Face mounting type

Technical Information Series DCM Cam Motor

Notes for Hydraulic Unit Use

Notes for fluid use

Inappropriate fluid use may induce malfunctions and failures.

Cautions

- Use an appropriately selected type of fluid.
- Do not mix different kinds of fluid nor mix fluid and lubricating oil.
- Fluid viscosity should comply with the values for the proper viscosity range in the specifications.
- Keep the fluid pollution limit set in the specifications to keep the fluid clean. If you keep using the contaminated fluid, it may induce malfunctions and damage of machinery.
- Fluid gets deteriorated with the times. Replace fluid regularly.
- Fluid should be filled from the inlet without getting foreign materials or water mixed during filling.
- Too low fluid surface level may induce malfunctions or failures. Keep the fluid level in the tank between the maximum and minimum levels for the oil gauge.
- Avoid contact of fluid with skin. In the event of the contact, wash well with soap. The contact may cause skin irritation. Avoid splash of fluid on people.
- Hot fluid may cause burns. Fluid replacement should be done after the fuel temperature gets low enough.

Danger

- As most of fluid is flammable, avoid fire or welding near the motor. It may catch fire.

Notes for hydraulic motor use

Read the instruction manual thoroughly before using hydraulic motors.

Use the right models

Caution

- Most of hydraulic equipment has the same or similar dimensions. Before mounting a pump or motor, check the model number plate or mark.

Danger

- Under any circumstances that may induce explosion or fire, use only the products suitable for the conditions.

Handling of products

Caution

- Handling hydraulic motors may cause injury. Wear protective gears if necessary.
- Most of hydraulic motors are heavy. Use due caution when handling the motors to prevent your hands from being caught or your low back from being damaged.
- Do not step on, beat, drop, or give any other kinds of force from outside on the motor. It may induce malfunctions, damage, or fluid leakage.
- If fluid is leaked on the motor or floor, wipe it thoroughly, or you may drop the motor or slip and get hurt.

Notes for Hydraulic Unit Use**Mounting, removal, piping, and wiring of hydraulic motors****⚠ Caution**

- Keep clean the mounting surface and holes of hydraulic motors. It may induce damage or fluid leakage due to looseness of the bolt or seal damage.
- For hydraulic motor mounting, be sure to use specified bolts and fasten them in specified torque. Incompliance with the specifications may induce malfunctions, damage or fluid leakage.
- Mounting, removal, piping, and wiring of hydraulic motors should be conducted by anyone with relevant expertise.
- Before mounting, removal, piping, or wiring of hydraulic motors, be sure to turn the unit power off, and make sure that the motor and engine are off. Depressurize and check no pressure is left in the hydraulic circuit any more.

Connecting rotating area**⚠ Warning**

- The connecting area of the rotating shaft of the hydraulic motor should be secured to avoid displacement of scattering during running. Be sure to attach a protective cover on the motor to prevent hands or clothes from being caught in.

Mounting hydraulic motor**⚠ Caution**

- Hydraulic motors should be mounted on an adequately robust base.
- Do not give any shock such as hammering to the pump or motor shafts when mounting or removing the motor. It may damage the motor.
- Core or side run-out for the hydraulic motor should be within the allowable range.
- Lay drain pipes in the hydraulic motor so that the pressure within the casing should not exceed specified values .
In addition, lay drain pipes so that the pipes are filled with hydraulic fluid without air mixed in the casing.

Maximum pressure limit**⚠ Warning**

- If you use any other pumps than those with pressure compensator (that is, maximum pressure adjustment), be sure to set relief valves near the pump discharge outlet to regulate maximum pressure of the hydraulic circuits.

To run hydraulic motors**⚠ Warning**

- Prior to running any unit equipped with a hydraulic motor, check the hydraulic circuit, electric wiring, and loose connecting area. Special attention should be paid to compatibility between electric control circuits and solenoid controlled valves. Conduct solenoid controlled valves one by one to check that the solenoid works as instructed.
- Before starting the hydraulic motor, check that the hydraulic pump is at neutral position, and run the engine in idling speed as low as possible. After about 5-minute continuous operation in this state, bleed pumps and motor cases of air. Confirm that the operation is normal without any fluid leakage, run the motor at a low speed under low load, and check that the alignment of the pump lever and motor rotation.
- Never run the motor with the rotator cover removed.
- Be careful not to get your clothes or gears caught in the rotator. Never touch the rotator.

Notes for Hydraulic Unit Use

⚠Caution

- When operating the hydraulic pumps and motors first time, or inspect or repair the hydraulic circuit, fill the casing with clean hydraulic oil.
- Check that drain line pressure in the hydraulic motor is within the allowable range.
- If the hydraulic motor running sound is larger than usual, cavitation may take place. Check the fluid tank level, clogging of a vacuum strainer or filter, or loose vacuum piping.
Especially, check that surge pressure produced at startup, stop, or shifting within the allowable range. (If it sounds different from normal operation, it may be caused by malfunction or failures. It is important to remember the sound of the normal operation and to find any possible error as soon as possible.)
- Hydraulic motors should be properly operated conforming to the right pressure, flow, speed, fluid type, temperature, and viscosity described on the instruction manual, catalogue, drawings, and specifications.
- The hydraulic motor casing may be heated. Do not touch the casing with your bare hand.
- If you recognize any unusual sound, heat, vibration, fluid leakage, smoke, smell, or any other anomalies in hydraulic motors, immediately stop the operation and take appropriate measures. Such anomalies may cause damage, fire, or injuries.

⚠Warning

- The brake built in the hydraulic motor only works as a parking brake (i.e. static brake). If it is used as a dynamic brake, it may cause the lining wear, resulting in brake torque drop.
- If you use a hydraulic motor for a vehicle's hydraulic drive system, the single hydraulic line cannot adequately decelerate, stop, or maintain the vehicle. Therefore, it is necessary to install a brake system that is independent from a hydraulic line as well as capable of those functions to adequately decelerate, stop, or maintain the drive system.

Hydraulic oil (hydraulic fluid) management

⚠Caution

- Operate the motor in the circuit configuration so that the fluid pollution range will always be within the range recommended by the manufacturer. Periodically inspect the pollution level and the filter. Furthermore, periodically inspect the oxidization, deterioration and the property such as moisture content of the hydraulic oil. If any of the checked values exceeds those recommended by the manufacturer, replace the hydraulic oil with new one.
- To change the fluid to be used, sufficiently flush throughout the circuit. Avoid mixing different kinds of fluid.

Maintenance

⚠Warning

- Do not remodel, disassemble, or reassemble the hydraulic motors. It may deteriorate the performances that are supposed to be shown, resulting in failures or accidents.

Notes for Hydraulic Unit Use**Maintenance and storage****⚠ Caution**

- If you are obliged to remodel, disassemble, or reassemble hydraulic motors, consult the manufacturer.
- To transport or store the hydraulic motors, pay attention to the environmental condition such as ambient temperature or humidity and keep them in a dust-proof and rust-proof area.
- Using hydraulic motors after long-time storage might need replacement of seals.



DCM0560

Technical Information Series DCM Cam Motor

Notes



Products we offer:

- Bent Axis Motors
- Closed Circuit Axial Piston Pumps and Motors
- Displays
- Electrohydraulic Power Steering
- Electrohydraulics
- Hydraulic Power Steering
- Integrated Systems
- Joysticks and Control Handles
- Microcontrollers and Software
- Open Circuit Axial Piston Pumps
- Orbital Motors
- PLUS+1® GUIDE
- Proportional Valves
- Sensors
- Steering
- Transit Mixer Drives

Danfoss Power Solutions is a global manufacturer and supplier of high-quality hydraulic and electronic components. We specialize in providing state-of-the-art technology and solutions that excel in the harsh operating conditions of the mobile off-highway market. Building on our extensive applications expertise, we work closely with our customers to ensure exceptional performance for a broad range of off-highway vehicles.

We help OEMs around the world speed up system development, reduce costs and bring vehicles to market faster.

Danfoss – Your Strongest Partner in Mobile Hydraulics.

Go to www.powersolutions.danfoss.com for further product information.

Wherever off-highway vehicles are at work, so is Danfoss.

We offer expert worldwide support for our customers, ensuring the best possible solutions for outstanding performance. And with an extensive network of Global Service Partners, we also provide comprehensive global service for all of our components.

Please contact the Danfoss Power Solution representative nearest you.

Comatrol

www.comatrol.com

Schwarzmueller-Inverter

www.schwarzmueller-inverter.com

Turolla

www.turollaocg.com

Valmova

www.valmova.com

Hydro-Gear

www.hydro-gear.com

Daikin-Sauer-Danfoss

www.daikin-sauer-danfoss.com

Local address:

Danfoss Power Solutions US Company

2800 East 13th Street
Ames, IA 50010, USA
Phone: +1 515 239 6000

Danfoss Power Solutions GmbH & Co. OHG

Krokamp 35
D-24539 Neumünster, Germany
Phone: +49 4321 871 0

Danfoss Power Solutions ApS

Nordborgvej 81
DK-6430 Nordborg, Denmark
Phone: +45 7488 2222

Danfoss Power Solutions (Shanghai) Co. Ltd.

Building #22, No. 1000 Jin Hai Rd
Jin Qiao, Pudong New District
Shanghai, China 201206
Phone: +86 21 3418 5200

Danfoss can accept no responsibility for possible errors in catalogues, brochures and other printed material. Danfoss reserves the right to alter its products without notice. This also applies to products already on order provided that such alterations can be made without consequential changes being necessary in specifications already agreed. All trademarks in this material are property of the respective companies. Danfoss and the Danfoss logotype are trademarks of Danfoss A/S. All rights reserved.