

## Data sheet

# Seated valves (PN 16)

**VRG 2** – 2-way valve, external thread

**VRG 3** – 3-way valve, external thread

### Description



VRG valves provide a quality, cost effective solution for most water and chilled applications.

The valves are designed to be combined with following actuators:

- With AMV(E) 335, AMV(E) 435 or AMV(E) 438 SU actuators.
- With AMV(E) 25, 25 SU/SD, 35 or AMV 323/423/523 actuators (with adapter **065Z0311**).

Combinations of actuators is evident under section "Dimension".

### Features:

- Bubble tight design
- Snap mechanical connection together with AMV(E) 335, AMV(E) 435
- Dedicated 2-port valve
- Suitable for diverting applications (3-port)

### Main data:

- DN 15-50
- $k_{vs}$  0,63-40 m<sup>3</sup>/h
- PN 16
- Temperature:
  - Circulation water / glycolic water up to 50 %: 2 (-10\*) ... 130 °C
  - \* At temperatures from -10 °C up to +2 °C use stem heater
- Connections:
  - External thread
- Compliance with Pressure Equipment Directive 97/23/EC

### Ordering

Example:  
3-way valve; DN 15;  $k_{vs}$  1,6; PN 16;  
 $T_{max}$  130 °C; ext. thread

- 1x VRG 3 DN 15 valve  
Code No.: **065Z0113**

Option:  
- 3x Tailpieces  
Code No.: **065Z0291**

### 2 & 3-way valves VRG (external thread)

Picture	DN	$k_{vs}$ (m <sup>3</sup> /h)	Code No.	
			VRG 2	VRG 3
	15	0,63	<b>065Z0131</b>	<b>065Z0111</b>
		1,0	<b>065Z0132</b>	<b>065Z0112</b>
		1,6	<b>065Z0133</b>	<b>065Z0113</b>
		2,5	<b>065Z0134</b>	<b>065Z0114</b>
		4,0	<b>065Z0135</b>	<b>065Z0115</b>
	20	6,3	<b>065Z0136</b>	<b>065Z0116</b>
	25	10	<b>065Z0137</b>	<b>065Z0117</b>
	32	16	<b>065Z0138</b>	<b>065Z0118</b>
	40	25	<b>065Z0139</b>	<b>065Z0119</b>
	50	40	<b>065Z0140</b>	<b>065Z0120</b>

Ordering (continued)

Accessories - Tailpieces

Type	DN	Code No.
Tailpiece <sup>1)</sup>	Rp 1/2	15 <b>065Z0291</b>
	Rp 3/4	20 <b>065Z0292</b>
	Rp 1	25 <b>065Z0293</b>
	Rp 1 1/4	32 <b>065Z0294</b>
	Rp 1 1/2	40 <b>065Z0295</b>
	Rp 2	50 <b>065Z0296</b>

<sup>1)</sup> 1 tailpiece internal thread for VRG ext. thread (Ms - CuZn39Pb3)

Accessories - Adapter & stem heater

Type	for actuators	Code No.
Adapter	AMV(E) 25/35/323/423/523	<b>065Z0311</b>
Stem heater	AMV(E) 335/435	<b>065Z0315</b>

Service kits

Type	DN	Code No.
Stuffing box	15	<b>065Z0321</b>
	20	<b>065Z0322</b>
	25	<b>065Z0323</b>
	32	<b>065Z0324</b>
	40/50	<b>065Z0325</b>

Technical data

Nominal diameter	DN	15					20	25	32	40	50
k <sub>vs</sub> value	m <sup>3</sup> /h	0,63	1,0	1,6	2,5	4,0	6,3	10	16	25	40
Stroke	mm	10							15		
Control range		30:1	50:1				100:1				
Control characteristic		LOG: port A-AB; LIN: port B-AB									
Cavitation factor z		≥ 0,4									
Leakage		A - AB bubble tight design									
		B - AB ≤ 1,0 % of k <sub>vs</sub>									
Nominal pressure	PN	16									
Max. closing pressure	bar	Mixing: 4									
		Diverting: 1									
Medium		Circulation water / glycolic water up to 50 %									
Medium pH		Min. 7, Max. 10									
Medium temperature	°C	2 (-10 <sup>1)</sup> ) ... 130									
Connections		ext. thread									
<b>Materials</b>											
Valve body		Grey cast iron EN-GJL-250 (GG-25)									
Valve stem		Stainless steel									
Valve cone		Brass									
Stuffing box sealing		EPDM									

<sup>1)</sup> At temperatures from -10 up to +2 °C use stem heater

Pressure temperature diagram

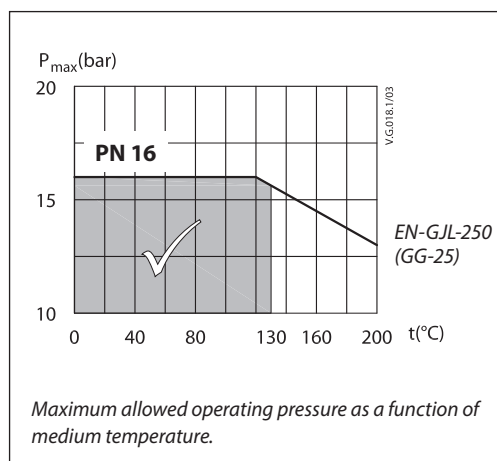

Valve characteristics

Valve characteristics log (2-way)

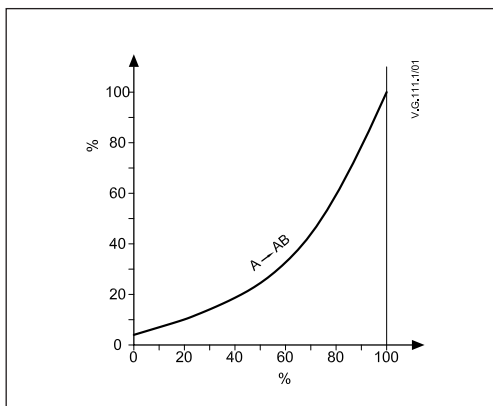

Valve characteristics log/lin (3-way)

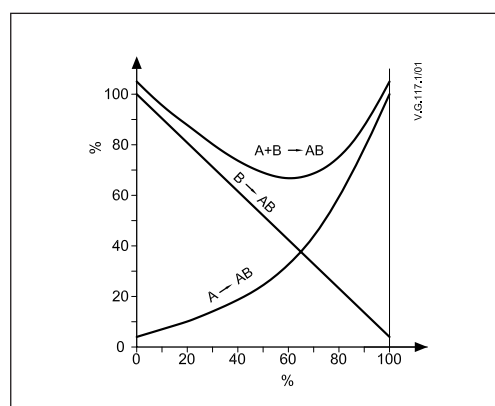

Installation

Valve mounting

Before valve mounting the pipes have to be cleaned and free from abrasion. Valve must be mounted according to flow direction as indicated on valve body except by diverting, where valve can be mounted opposite to the flow direction (flow opposite to indication on the valve body). Mechanical loads of the valve body caused by the pipes are not allowed. Valve should be free of vibrations as well.

Installation of the valve with the actuator is allowed in horizontal position or upwards. Installation downwards is not allowed.

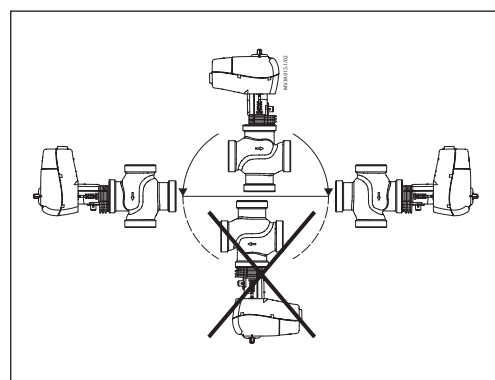

Note:

Install a strainer upstream of the valve (e.g. Danfoss FVR/FVF)

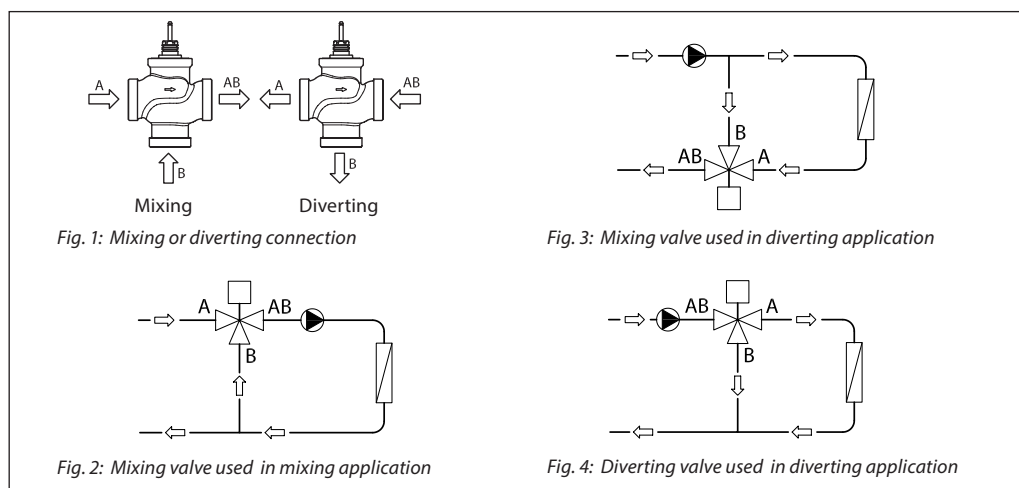
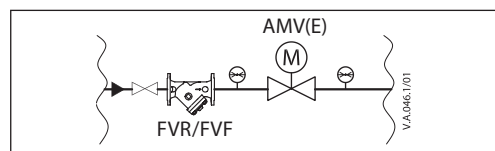

Mixing or diverting connection

3-way valve can be used either as mixing or diverting valve (fig.1).

If 3-way valve is installed as mixing valve meaning that A and B ports are inlet ports, and AB port is outlet port it can be installed in mixing (fig.2) or diverting application (fig.3).

3-way valve can be also installed as diverting valve in diverting application (fig.4) meaning that AB port is inlet and A and B ports are outlets.

**Note:** Maximal closing pressure for mixing and diverting installation are not the same. Please refer to values stated in Technical data section.

Disposal

The valve must be dismantled and the elements sorted into various material groups before disposal.

Sizing

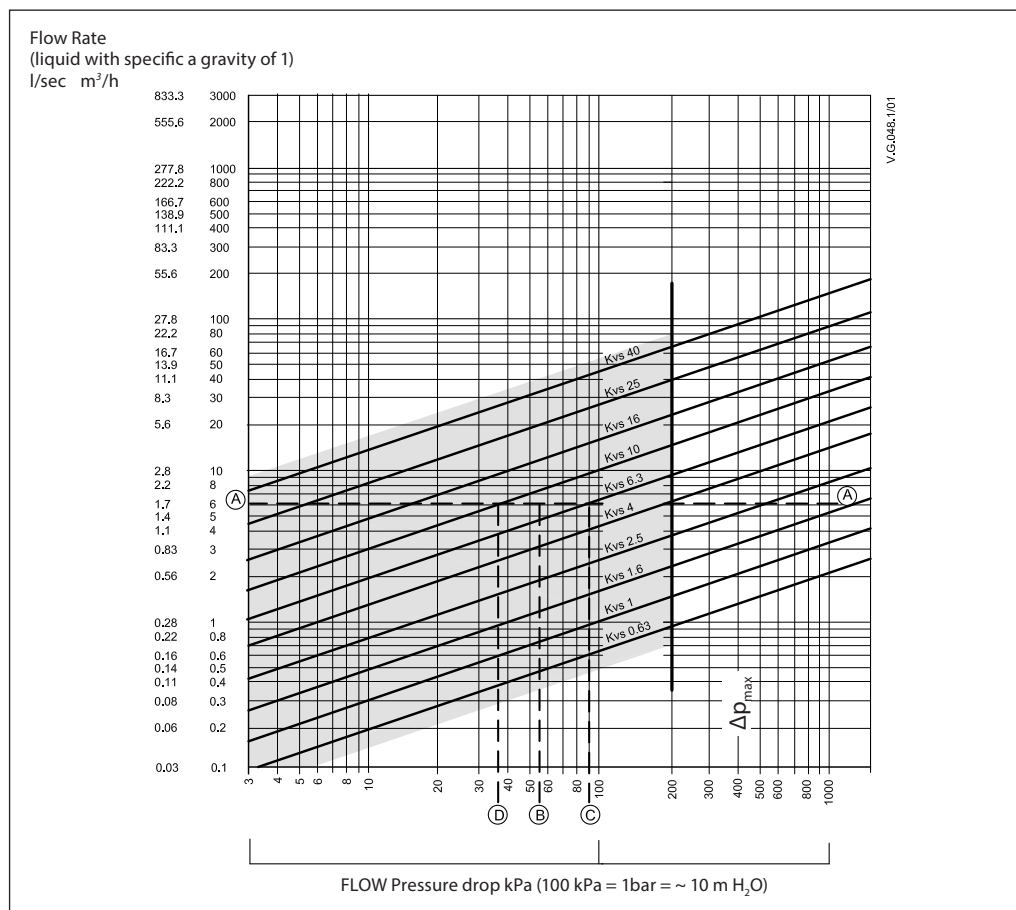

Example

*Design data:*  
 Flow rate: 6 m<sup>3</sup>/h  
 System pressure drop: 55 kPa

Locate the horizontal line representing a flow rate of 6 m<sup>3</sup>/h (line A-A). The valve authority is given by the equation:

$$\text{Valve authority, } a = \frac{\Delta p_1}{\Delta p_1 + \Delta p_2}$$

Where:

$\Delta p_1$  = pressure drop across the fully open valve

$\Delta p_2$  = pressure drop across the rest of the circuit with a full open valve

The ideal valve would give a pressure drop equal to the system pressure drop (i.e. an authority of 0,5):

if:  $\Delta p_1 = \Delta p_2$

$$a = \frac{\Delta p_1}{2 \times \Delta p_1} = 0,5$$

In this example an authority of 0,5 would be given by a valve having a pressure drop of 55 kPa at that flow rate (point B). The intersection of line A-A with a vertical line drawn from B lies between two diagonal lines; this means that no ideally-sized valve is available.

The intersection of line A-A with the diagonal lines gives the pressure drops stated by real, rather than ideal, valves. In this case, a valve with  $k_{vs}$  6,3 would give a pressure drop of 90,7 kPa (point C):

$$\text{hence valve authority} = \frac{90,7}{90,7 + 55} = 0,62$$

The second largest valve, with  $k_{vs}$  10, would give a pressure drop of 36 kPa (point D):

$$\text{hence valve authority} = \frac{36}{36 + 55} = 0,395$$

Generally, for a 3 port application, the smaller valve would be selected (resulting in a valve authority higher than 0,5 and therefore improved control). However, this will increase the total pressure and should be checked by the system designer for compatibility with available pump heads, etc. The ideal authority is 0,5 with a preferred range of between 0,4 and 0,7.

**Design**

*(Design variations are possible)*

**VRG 2**

- 1. Valve body
- 2. Valve insert
- 3. Valve cone
- 4. Valve stem
- 5. Moving valve seat (pressure relieved)
- 6. Stuffing box

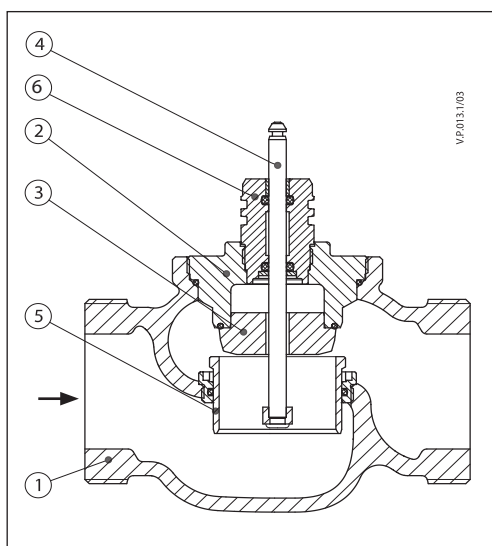

**VRG 3**

- 1. Valve body
- 2. Valve insert
- 3. Valve cone
- 4. Valve stem
- 5. Valve seat
- 6. Pressure relieve chamber
- 7. Stuffing box

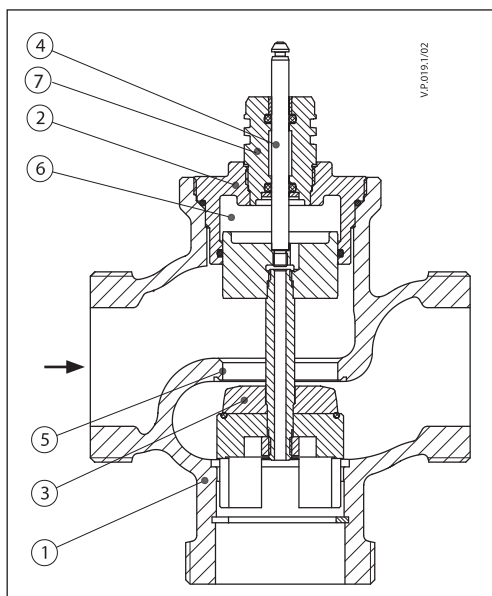

Dimensions

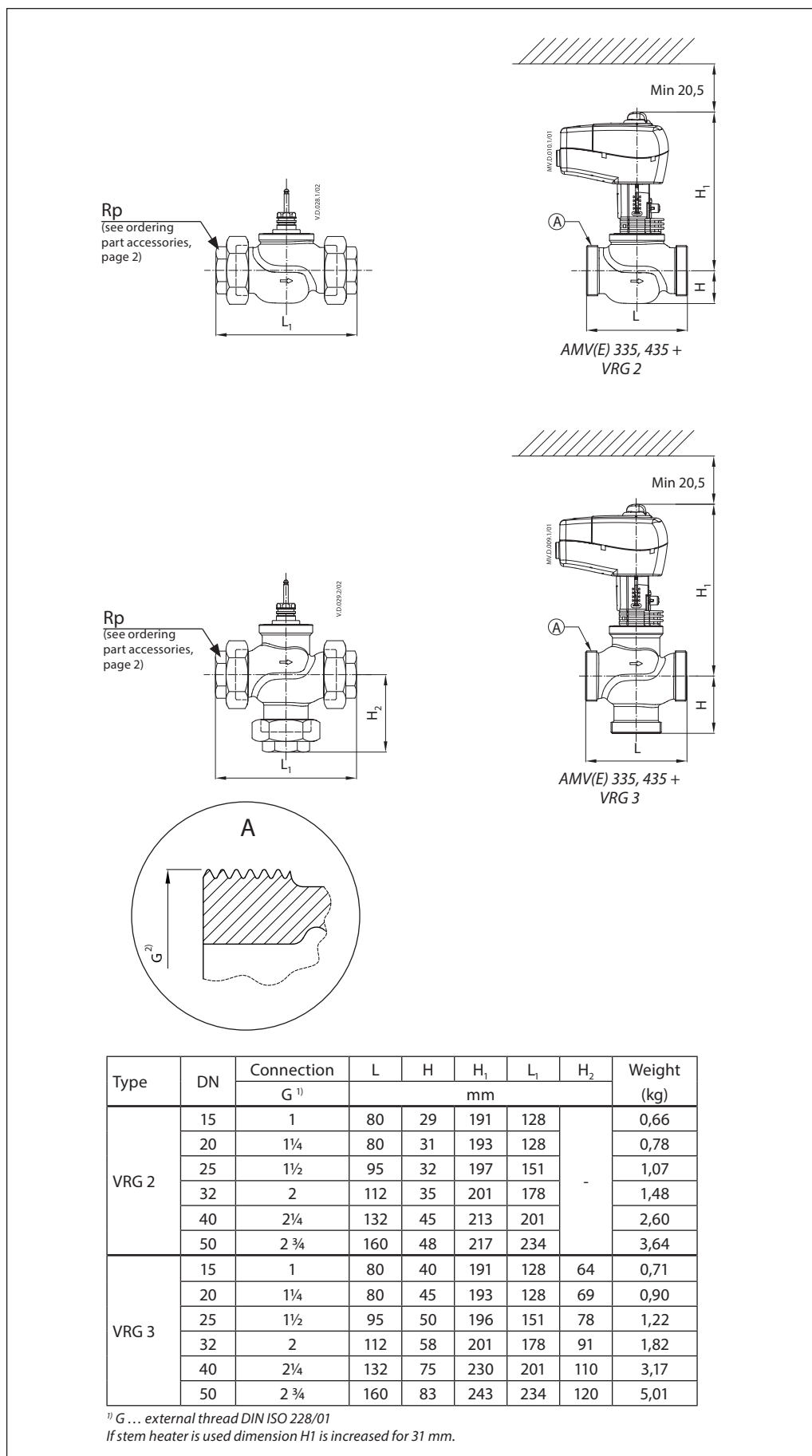

Dimensions (continued)

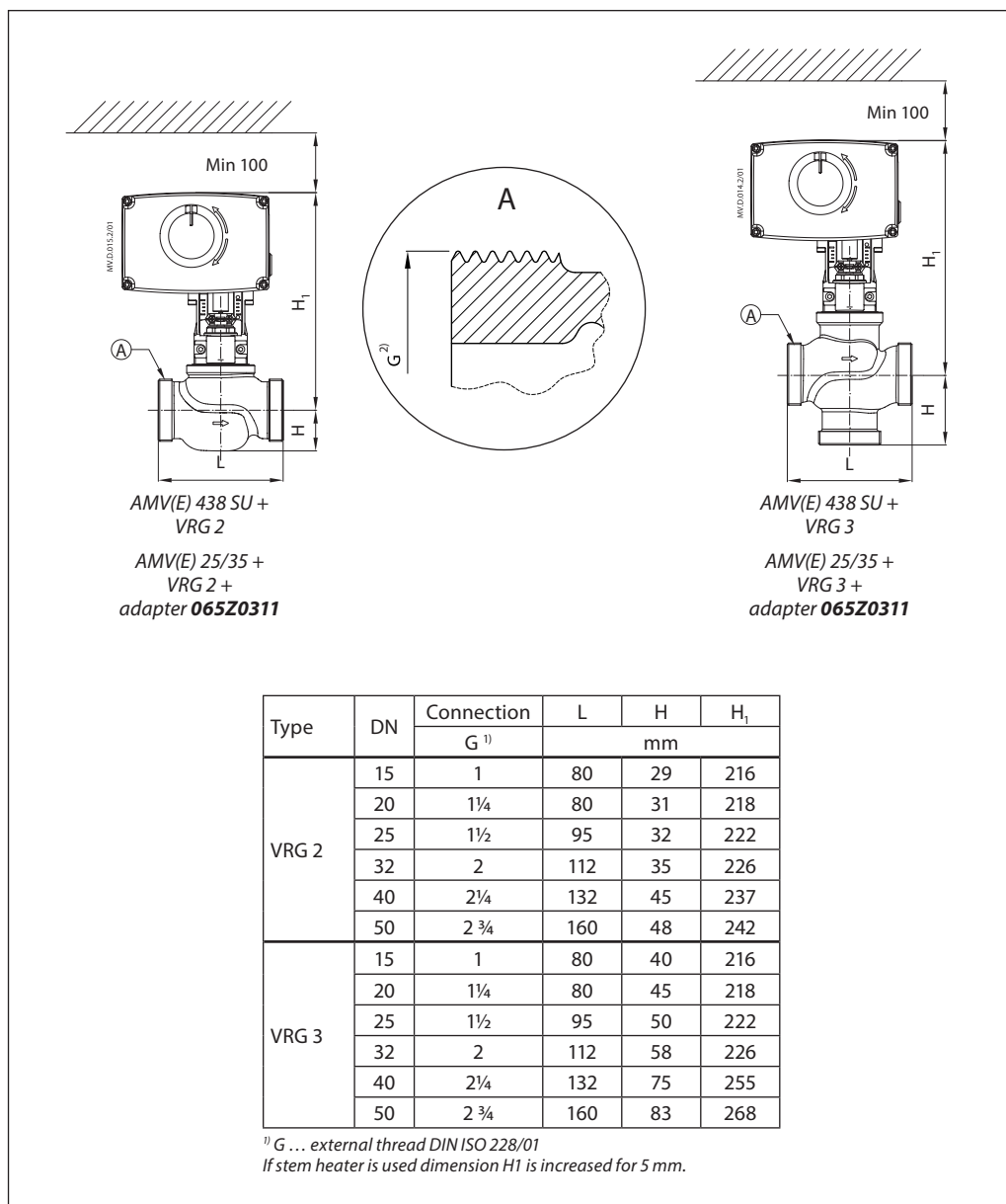

Dimensions (continued)

